

T6 is a trade name of Trol Systems Inc.
TSI reserves the right to make changes to the information contained in this manual without notice.
publication RCP-2MAN- rev: 4 | © 2002 TSI All rights reserved | printed in USA

Remote Counter Panel

Operating Manual
for part number:
RCP-02

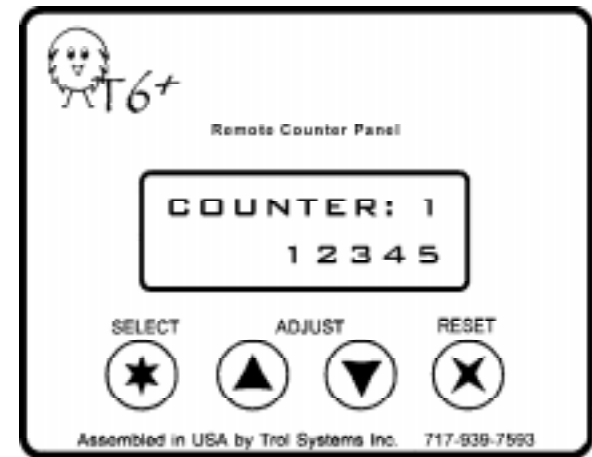

Specifications

Part No:

RCP-02, w/ software version 1.01

Physical:

3.2" (81.5mm) wide, 2.55" (65mm) high, 1.25" (32mm) deep polycarbonate overlay over .058" thick aluminum face plate
.06" thick neoprene gasket seals to NEMA type 12 protection
supplied data cable is 30" (763mm) long

Display:

2 line x 12 character super twist LCD, 40 degree viewing angle
character size is .25" (6.20mm) high, by .13" (3.2mm) wide
operating temperature range 0 to 50 deg. C. (32 to 120 deg. F.)
storage temperature range -20 to 70 deg. C. (-4 to 158 deg. F.)

Power Requirements

power is supplied by the T6+ MCU via data cable, 5 volts maximum

Performance:

each counter can be operated by any page, any number of times
counting range is 0 to 59,999
count speed is 100cps, which is limited by the MCU line execution
15 individual messages, each containing up to 24 characters
counter settings and messages are stored internally via nonvolatile eeprom which does not require battery backup.

OEM considerations:

Custom cable lengths for the RCP are available. Panel units can be setup on a personal computer, using the Computer Interface Module with a power pack (part nos. CIM-03 & 30101). Writing messages on a keyboard is quick and easy. Additional panel units can then be cloned, eliminating the need to setup each panel individually.

For additional information and tips on using the RCP and other T6 equipment, visit our web site at www.trolsystems.com. Customer FAQs and feedback will be posted as it becomes available. We welcome any comments that you'd like to send us.

Features

Some machine applications require the operator to view counters and make frequent adjustments to count settings. The Remote Counter Panel (RCP) allows easy adjustments for up to eight counters while the machine is running. Here are some key features of the RCP:

- **Save Count:** Each counter can be set to save its count status when the power is turned off. This allows the machine to finish an interrupted counting cycle.
- **Bidirectional:** Each counter can be incremented or decremented, so they can be displayed as "count remaining" or "count accumulated".
- **Adjustment Window:** Each counter can be limited to a selected range of adjustment. You determine how wide this adjustment window should be. The counter will begin at the new adjusted preset when it is reset.
- **Save Adjustment Mode:** You choose whether adjustments to the counter are saved or not. If it's not saved, the counter would be restored to the initial programmed setting when the system is powered up.
- **Counter Names:** You can assign a name to any counter (up to 12 characters long). For example; counter 3 could be named "PARTS IN BOX" with the count shown on the bottom line.
- **Messages:** Up to 15 individual messages can be shown on the panel. Each message is 24 characters long and can be made up of letters, numbers and symbols.
- **Send & Receive Data:** Once setup for operation of counters and messages, additional remote counter panels can be "cloned". This eliminates needing to manually setup each panel. A program transfer module, part number PTM-02 or Computer Interface Module CIM-03, is required.

Installation

The display will require cutting out a rectangular section of the panel with a reciprocating saw or nibbling tool. Use the peel & stick template (included) as a guide to locate the panel. Use a center punch to prevent the drill bit from "walking". Drill the four holes using a 1/4" bit. Use a sheet metal blade (18 to 36 tpi) to cut between the outer side of the holes.

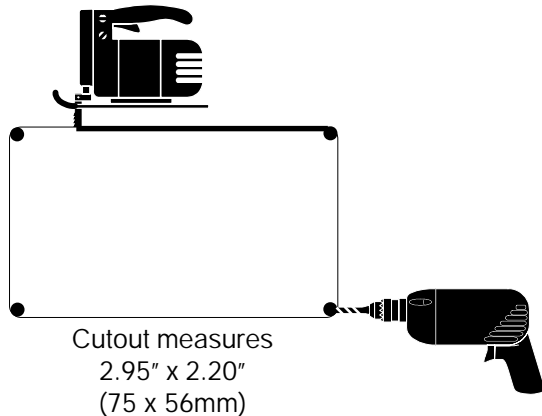

After the panel is drilled and cut, remove all burrs and file down rough edges. Check to make sure that the panel is still flat. Mounting the display on a distorted panel may cause improper operation of the adjustment keys. Install the panel display into the cutout.

Using the supplied nuts and special washers, tighten the nuts until they pull the display snugly against the panel. Be careful not to overtighten the nuts. Use of thread-lock liquid is recommended where the panel is subjected to vibration.

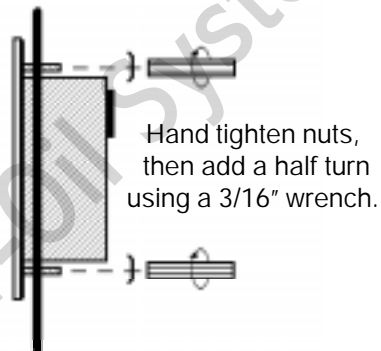

Note: The washers should be oriented so that one edge reaches out to grip the panel while the other edge rests against or over the gasket of the RCP. This will cause the washer to look uneven when properly installed.

Adjusting counters

The counter panel allows you to adjust counters while the machine is running, without interfering with the operation of the MCU. Only counters that were setup for operation using the Setup menu can be accessed. If you adjust a counter that is currently running, the adjusted setting will be used for the next timing cycle.

Here's how the keys operate when the machine is running:

SELECT which of the eight counters that you want to adjust or view. The panel will enter the Adjust mode while the MCU continues running. Only counters that are setup for operation are displayed*.

ADJUST the count setting higher or lower. The counter adjustment will scroll faster as the adjust key is pressed and stop when a High or Low limit of the counter is reached. A short time after releasing the Adjust key, the new count adjustment is saved (if allowed by setup) and the panel will return to the run mode.

RESET the selected counter to its current count setting (if allowed by setup).

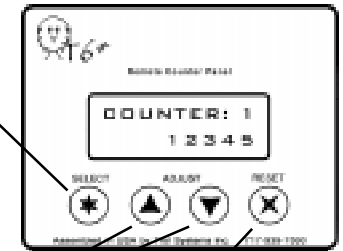

* Once a counter is setup, it will be one of those that is displayed when the Select key is pressed. If you no longer want a counter to be displayed, go to the Setup Options menu and choose to remove it.

Operation

All counter parameters, (such as its setting, limits of adjustment, name, etc.) reside in the memory of the panel unit. When a "counter" function is executed by the MCU, it determines what happens to the counters and what is displayed on the panel. Any page of the MCU can contain the counter function and there is no limit how many times it's used.

Here's an example of how the program of a golf ball dispensing machine would work with the panel.

MCU Program & (notation)

1. Counter - Display Message 1 — — — — —
2. Check input 1-On (box present sensor)
3. Output 4-turn on (begin ball conveyer)
4. Check input 2- On (ball count sensor)
5. Check input 2- Off *
6. Counter 1 - Increment & display — — — — —
7. Counter 1- at 100?, if not mot to line 4
8. Output 4- turn off (stop ball conveyer)
9. Counter 2 - Increment, do not display **
10. Counter - Display Message 2 — — — — —
11. Check input 1- Off (confirm box is removed)
12. End Page

**INSERT BOX
TO BEGIN**

**BALL COUNT
1**

**BALL COUNT
100**

**REMOVE BOX
OF 100 BALLS**

* Remember to check the input to turn back off. This avoids having multiple counts of the same ball.

** Counter #2 indicates the total number of boxes that where filled. It was programmed not to be displayed so that Counter #1 is shown (ball counter). The machine operator may view the status Counter #2 at any time, by pressing the "select" key.

Installation

Plug the data cable into the panel display, and plug the other end of the cable into one* of the data ports of the MCU. For optimum performance, avoid placing the data cable near (especially parallel to) any wiring that carries power. Plug the pocket programmer into the other data port of the MCU. The pocket programmer must be set up to include new counter functions in the program menu by following the instructions below.

Note: If using a Computer Interface Module (CIM-03), the following setup procedure can be done using the T6 program (version 2.20 or higher).

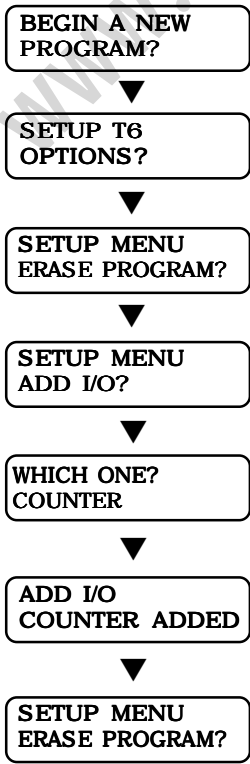

Power up the pocket programmer (by MCU or optional power pack) and enter the Main menu.

At the Main menu choose "setup T6 options", then press the Enter key.

In the Setup menu choose "add I/O", then press the Enter key.

Select "Counter", then press the Enter key.

The Setup Menu will reappear. Press the Back key to return to the Main menu. The counter function is now added to the Program menu.

* If there is only one data port on the MCU, it is a standard T6. You must have a T6+ MCU and programmer in order to use this panel display. Please contact your distributor.

Setup Menu

The RCP must be set up to operate the counters and messages that will be controlled by the MCU. To access the Setup Menu, the RCP must be connected to the data port of the MCU. Plug the pocket programmer into the other data port of the MCU (or the open port of the last I/O section in the system). Apply power to the MCU. The MCU will detect the programmer and will not automatically begin the Run mode.

**x counters
are setup**

Press the "Select" and "Reset" keys of the RCP at the same time to enter the Setup menu. The Setup menu choices are listed below.

**setup menu
counter: 1**

See the next page for instructions on setting up the counters.

**setup menu
messages**

See "Setup Messages" page for instructions on how to set up a message for display.

**setup menu
options**

Choose "Options" to remove a counter from setup so that it can no longer be selected by the machine operator. The Options menu also contains choices to send and receive data. Please refer to the instructions supplied with the optional Program Transfer Module.

**setup menu
exit**

Select "Exit" to leave the Setup menu and return the panel to normal operation.

Note: After the Pocket Programmer has been disconnected from the data port of the MCU, the Setup menu cannot be accessed by the machine operator. Therefore, you should keep the programmer in a secure place to prohibit tinkering with the settings of the RCP or the MCU's program.

Operation

When the MCU executes a counter function, it sends a command for the RCP to do one of the following:

- display a counter
- display a message
- increment, decrement or reset a counter
- send the current status of a counter

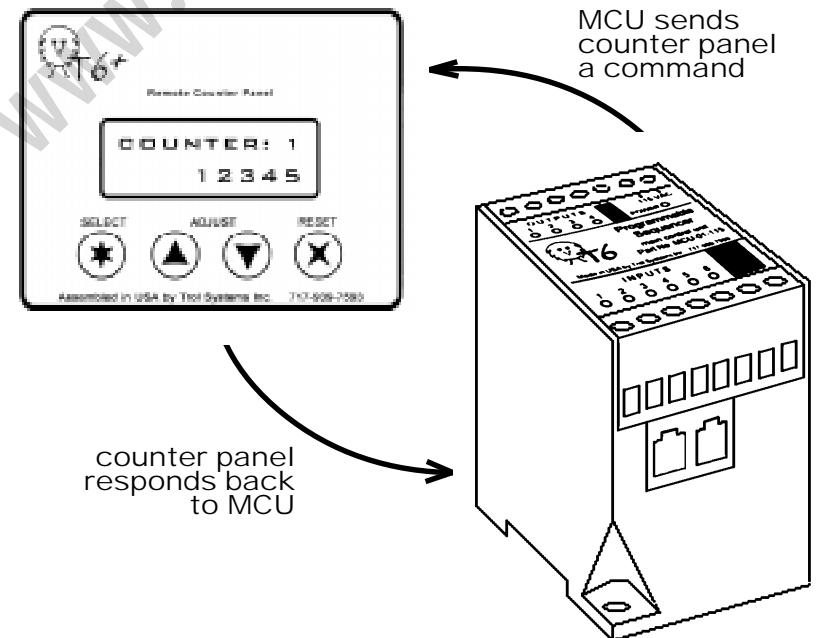

The Panel display responds to the MCU's command by:

- displaying the information requested
- resetting the instructed counter to its preset number
- sending the status of the counter as the MCU had requested

Messages

Message No: C10

— — — — — — — — — — — — — — — —
— — — — — — — — — — — — — — — —

Message No: C11

— — — — — — — — — — — — — — — —
— — — — — — — — — — — — — — — —

Message No: C12

— — — — — — — — — — — — — — — —
— — — — — — — — — — — — — — — —

Message No: C13

— — — — — — — — — — — — — — — —
— — — — — — — — — — — — — — — —

Message No: C14

— — — — — — — — — — — — — — — —
— — — — — — — — — — — — — — — —

Message No: C15

— — — — — — — — — — — — — — — —
— — — — — — — — — — — — — — — —

Setup Counters

All counters that will be controlled by the MCU, must be setup. If using a Computer Interface Module, the setup can be done by accessing the Setup Menu. Otherwise, the panel must be setup manually. Use a pencil to write down the settings of each counter on the next two pages. This information is helpful when programming the MCU. Start by accessing the Setup Menu of the RCP, then follow these steps:

Step 1: Using the Adjust keys, select one of the eight counters that you'd like to setup, then press the Enter key.

Step 2: Set the COUNT preset for this counter. This is the setting that is adjusted by the machine operator. The Select key moves the cursor to the left. The Reset key moves the cursor to the right until "OK" appears. If the Reset key is pressed then, the count setting is stored.

Step 3: Set the HIGH limit of adjustment for this counter.

Step 4: Set the LOW limit of adjustment for this counter.

Step 5: Choose whether or not adjustments to the counter should be remembered. If not, the counter goes back to the original setting (of step #2) when the MCU is powered up.

Step 6: Choose whether or not the machine operator is able to reset this counter using the Reset button on the panel.

Step 7: Choose whether or not this counter should remember what its count was when power is turned off.

Step 8: Choose whether you want to NAME the counter. (The name is what is displayed to the machine operator on the panel, it will still be referred to by its number in the pocket programmer.) If you select NO, the counter's name remains unchanged. If you choose YES, a cursor will appear under the top left character of the counter's name. Use the Adjust keys to select a character to be placed in this space. Press the Reset key to move on to the next space (Select key to backspace). When the last (12th) character is selected, the counter has been renamed.

After step 8, the Setup Menu will return to Step 1. If your finished setting up the counters, choose EXIT to return the panel to normal operation.

Counter Settings

Counter 1 is used for: _____

set count: _____ high limit: _____ low limit: _____

Remember changes? yes no Allow panel reset? yes no

Remember count? yes no Name counter? yes no

Name: _____

Counter 2 is used for: _____

set count: _____ high limit: _____ low limit: _____

Remember changes? yes no Allow panel reset? yes no

Remember count? yes no Name counter? yes no

Name: _____

Counter 3 is used for: _____

set count: _____ high limit: _____ low limit: _____

Remember changes? yes no Allow panel reset? yes no

Remember count? yes no Name counter? yes no

Name: _____

Counter 4 is used for: _____

set count: _____ high limit: _____ low limit: _____

Remember changes? yes no Allow panel reset? yes no

Remember count? yes no Name counter? yes no

Name: _____

Messages

Message No: C4

Message No: C5

Message No: C6

Message No: C7

Message No: C8

Message No: C9

Setup Messages

In addition to displaying counters, you can also display up to 15 different messages. Each message contains two lines of 12 characters. The choice of characters includes uppercase, lowercase, numbers and symbols.

To program messages, access the setup menu. Select "messages", then choose the message number that you'd like to program. The cursor will begin at the upper left hand corner. Use the Adjust keys to select the character, then press the Enter to move to the next space (Select key to backspace). When the last character is entered, the message is finished. Since there are two types of panels- messages for the timer panel are designated with a "T" and messages for the counter panel are designated "C".

Tip: Use a pencil to write down your messages on the following templates first. This will help you to plan how it should look. Then check off the box above the message after you finish programming it.

Message No: C1

----- -----

Message No: C2

----- -----

Message No: C3

----- -----

Counter Settings

Counter 5 is used for: _____

set count: _____ high limit: _____ low limit: _____

Remember changes? yes no Allow panel reset? yes no

Remember count? yes no Name counter? yes no

Name: _____

Counter 6 is used for: _____

set count: _____ high limit: _____ low limit: _____

Remember changes? yes no Allow panel reset? yes no

Remember count? yes no Name counter? yes no

Name: _____

Counter 7 is used for: _____

set count: _____ high limit: _____ low limit: _____

Remember changes? yes no Allow panel reset? yes no

Remember count? yes no Name counter? yes no

Name: _____

Counter 8 is used for: _____

set count: _____ high limit: _____ low limit: _____

Remember changes? yes no Allow panel reset? yes no

Remember count? yes no Name counter? yes no

Name: _____

Counter Functions

Once the pocket programmer was setup for the RCP, a new "counter" function will appear in the program menu. You may choose to control one of the eight counts or to display a message (see next page). After choosing a counter, you'll need to select what the MCU should do with the counter:

Increment it - The count will be increased by one. It will not be increased when the count reaches 59,999. This function also has the option of whether or not this counter should be displayed at this point in the program.

Decrement it - The count will be decreased by one. It will not be decreased when the count reaches zero. This function also has the option of whether or not this counter should be displayed at this point in the program.

Display it - The counter is displayed on the panel instead of whatever previously may have been displayed.

Is at or above - The selected counter is checked to see if it is at or above a specified amount of count. If it is, the page will go onto the next line. If it isn't, you can choose to move to some other line of the page.

Is at or below - The selected counter is checked to see if it is at or below a specified amount of count. If it is, the page will go onto the next line. If it isn't, you can choose to move to some other line of the page.

Reset it - The counter will go back to its preset count status.

Notice: If the MCU is programmed to control a counter, the counter must then be setup for operation on the RCP (see page 5). Failure to do so may cause the MCU to halt execution at that line.

Counter Function: Messages

When programming a line of the MCU for the counter function, one of the choices is to display a message. To do this:

- Choose the "counter" function.
- When prompted to choose a counter, scroll past counter number 8 and the prompt "Display Message" will appear. Press the Enter key.
- Choose which one of the 15 messages that you want displayed, then press Enter. The line is now programmed to display the selected message.

After the choice of a message is entered, the programmer will advance to the next line.

Reminder: The RCP will display only what the MCU is programmed to display using the counter function. The last thing displayed is the last thing instructed by the MCU. If you haven't already; be sure to setup each of the messages that you have programmed the MCU to display.

Tip: Allow a sufficient amount of time between displaying different messages. For example, imagine that we programmed two lines to display a message and one immediately follows the other. The second message would be displayed only 1ms later than the first message. It would appear that the first message was never displayed. If we inserted a line in-between and programmed it to wait for a few seconds, we would then be able to see the first message. Consider using one of the other pages to perform the task of displaying multiple messages so that Page A could be dedicated to running the machine.

If you'd like the panel to be blank at some point: program the MCU to display a message that was setup with blanks selected for each character.