

# MXE ELECTRIC ACTUATORS

**ENDURANCE TECHNOLOGY<sup>SM</sup>**

**S SOLID BEARING**

**P PROFILED RAIL**



**MAXIMUM DURABILITY**

# THE MXE ELECTRIC ACTUATOR – DESIGNED TO OUTLAST EVERY RODLESS ACTUATOR ON THE MARKET

The MXE electric actuator is exactly what you expect from the industry's number one rodless supplier. Designed with our exclusive **ENDURANCE TECHNOLOGY™** features, the MX delivers superior performance to meet the most demanding applications. Nobody knows rodless like Tolomatic, and the MX proves it.

- **DURABLE BEARINGS.** Two bearing choices to match your application needs. Solid bearing design optimizes stress distribution for optimal performance. Profiled rail design uses THK® Caged Ball® technology to reduce friction and extend actuator life.
- **DURABLE BANDS.** Stainless steel bands are stronger and will not elongate like elastomer (non-metallic) bands, providing a reliable seal over the life of the actuator.

**Choose from our broad line of MX products: MXP pneumatic rodless cylinders and MXE electric actuators. World class product performance, five days built-to-order and legendary customer service . . . what you expect from the leader . . . Tolomatic!**



## **[S]-SOLID BEARING**

- Large bearing surface contact area optimizes stress distribution on bearing for long service life
- Large carrier mounting pattern for more load stability and compatibility with existing BCS applications
- Engineered bearing material does not require additional lubrication
- Solid bearings are field replaceable

## **[P]-PROFILED RAIL**

- THK® Caged Ball® bearings with reduced friction for reliable service life
- High load and bending moment capacities
- Low profile to fit your application
- High precision bearings feature smooth, low breakaway motion



# SELECT THE PERFORMANCE YOU NEED

Choose from: • Two Bearing Models • Three Actuator Sizes (six by the end of 2007) • Built to Your Specified Stroke Length!

## MOMENT & LOAD CAPACITY COMPARISON

Graph for model comparison, data from MXE40 actuator

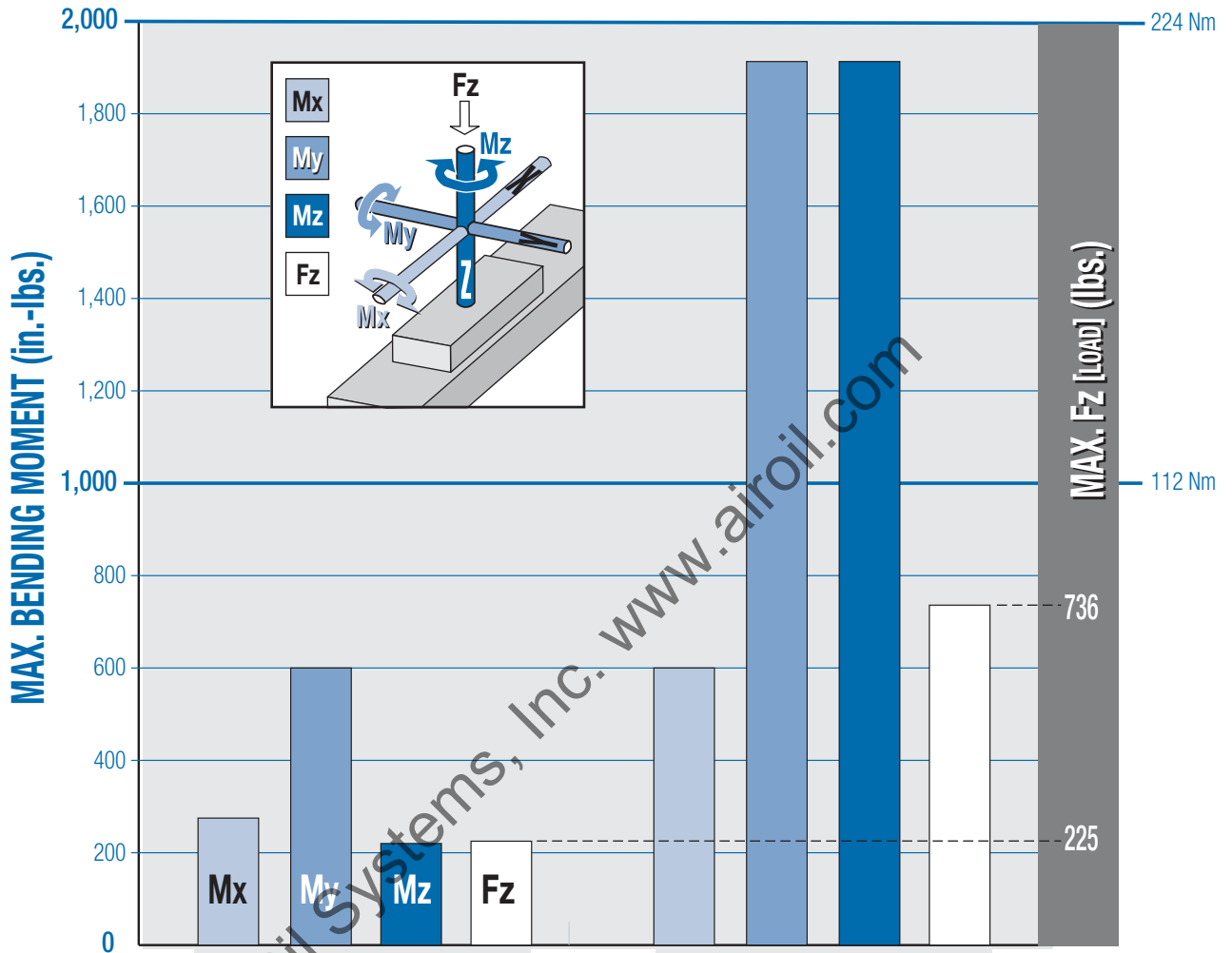

Airoil Systems, Inc. www.airoil.com

Tolomatic MX  
Electric Actuator  
Model



<b>Bearing Type</b>	Solid Bearing	Profiled Rail
<b>Moment Capacity</b>	Moderate + Mx Capacity	High
<b>Ideal Applications</b>	<ul style="list-style-type: none"> <li>• Side Loads</li> <li>• Impact Loads</li> </ul>	<ul style="list-style-type: none"> <li>• High Moment Loads</li> <li>• High Speeds with Heavy Loads</li> <li>• High Precision</li> </ul>
<b>Product Features</b>	Page 4	Page 6

# S SOLID BEARING

## ENDURANCE TECHNOLOGY<sup>SM</sup>

Endurance Technology features are designed for maximum durability to provide extended service life.

### STAINLESS STEEL BAND

- Exterior dust band made of fatigue resistant stainless steel



STAINLESS STEEL IS DURABLE, FLEXIBLE AND CORROSION FREE



### LARGE FLEXIBLE MOUNTING PATTERN

- Carrier gives more load stability
- Compatibility with existing BCS applications
- More fastening options

### DUST WIPER

- Formed end cap and side dust wipers keep contaminants from entering the actuator's internal area

### RETAINED DUST BAND

- Retained dust band keeps contaminants from entering the actuator interior, protecting components for reduced maintenance and increased uptime

### MULTIPLE SCREW TECHNOLOGIES

#### YOU CAN CHOOSE:

- Solid nuts of engineered resins for quiet performance at the lowest cost - 5 choices
- Ball nuts offer positioning accuracy and repeatability with longer life, low-backlash available - 3 choices



### NON-WEAR BAND RETENTION

- Magnetically retained band is not subject to wear as are mechanically retained systems

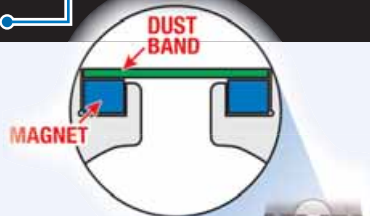

**• INCH OR METRIC MOUNTING •**

- Your choice of inch (*US standard*) or metric mounting to the carrier

**• YOUR MOTOR HERE •**

**YOU CAN CHOOSE:**

- Motor or gearbox supplied and installed by Tolomatic
- Specify the device to be installed and actuator ships with proper mounting hardware - MXE is a "Your Motor Here" actuator for easy in-line motor installation. Check our website for complete YMH information
- Specify and ship your device to Tolomatic for factory installation

**• MOTOR ORIENTATION •**

**YOU CAN CHOOSE:**

- In-line option directly couples the driving shaft and is a one-piece housing construction for optimum alignment and support of the motor
- Reverse-parallel option minimizes the overall length and offers a 1:1 or 2:1 belt ratio

**• NON-BINDING BEARING ARMS •**

- Bearings are tensioned indirectly, providing bind free adjustment

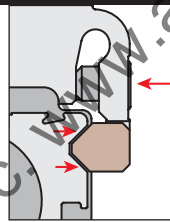

**• TRAPEZOIDAL BEARINGS •**

- Trapezoidal design maximizes bearing surface area for less pressure on bearing surfaces; less pressure results in less wear
- Engineered bearing material has low static and dynamic friction with low wear properties for long lasting, smooth operation
- Bearings are field replaceable for extended service life



NOTE: Boxed letters indicate ordering codes

**OPTIONS**



**AUXILIARY CARRIER DC**

- 2X higher Fz (load) capacity
- High bending moment capacity



**FLOATING MOUNT FL**

- Compensates for non-parallelism between MX actuator and externally guided load



**TUBE CLAMPS TC**

- Used for intermediate support
- Flush with bottom of actuator to retain low profile
- Drop-in, adjustable mounting locations



**MOUNTING PLATES MP**

- To provide clearance for motor and mount
- Use in conjunction with tube clamps



**SWITCHES**

- Largest number of sensing choices in the industry: Reed, Solid State PNP or NPN, all available normally open or normally closed
- Flush mount, drop-in installation
- Bright LEDs, power & signal indication
- CE rated, RoHS compliant

**• INTERNAL MAGNETS •**

- Standard feature that allows sensor installation anytime on the open side or bottom of the extrusion

# P PROFILED RAIL

## ENDURANCE TECHNOLOGY<sup>SM</sup>

Endurance Technology features are designed for maximum durability to provide extended service life.

### CAGED BALL<sup>®</sup> BEARINGS

- THK<sup>®</sup> Caged Ball<sup>®</sup> bearings are used to reduce friction and extend actuator life
- Caged Ball<sup>®</sup> technology creates a grease pocket between ball elements, reducing friction, noise and maintenance
- Large permissible moment loads
- High speed operation, low heat generation
- High precision, smooth, low friction motion

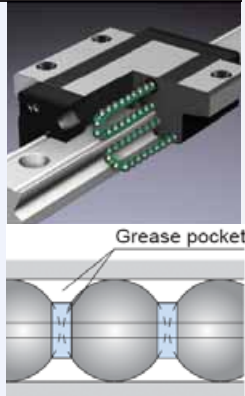

### INTERNAL MAGNETS

- Standard feature that allows sensor installation anytime on the open side or bottom of the extrusion

### DUST WIPER

- Formed end cap and side dust wipers keep contaminants from entering the actuator's internal area

### STAINLESS STEEL BAND

- Exterior dust band made of fatigue resistant stainless steel

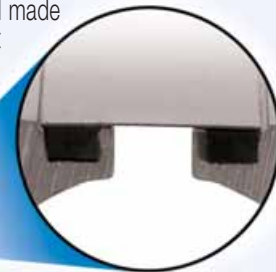

**STAINLESS STEEL IS DURABLE, FLEXIBLE AND CORROSION FREE**

### INCH OR METRIC MOUNTING

- Your choice of inch (US standard) or metric mounting to the carrier

## • LOW CARRIER HEIGHT •

- Reduces overall actuator envelope
- Large mounting pattern for high load stability

## • YOUR MOTOR HERE •

### YOU CAN CHOOSE:

- Motor or gearbox supplied and installed by Tolomatic
- Specify the device to be installed and actuator ships with proper mounting hardware - MXE is a "Your Motor Here" actuator for easy in-line motor installation. Check our website for complete YMH information
- Specify and ship your device to Tolomatic for factory installation

## • MOTOR ORIENTATION •

### YOU CAN CHOOSE:

- In-line option directly couples the driving shaft and is a one-piece housing construction for optimum alignment and support of the motor
- Reverse-parallel option minimizes the overall length and offers a 1:1 or 2:1 belt ratio

## • RETAINED DUST BAND •

- Retained dust band keeps contaminants from entering the actuator interior, protecting components for reduced maintenance and increased uptime

## • NON-WEAR BAND RETENTION •

- Magnetically retained band is not subject to wear as are mechanically retained systems
- Immediate band engagement and release results in less drag on carrier for lower friction force during initial carrier movement

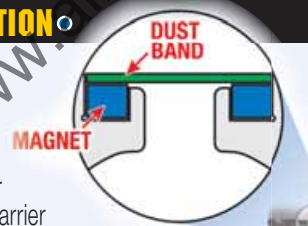

NOTE: Boxed letters indicate ordering codes

## • MULTIPLE SCREW TECHNOLOGIES •

### YOU CAN CHOOSE:

- Solid nuts of engineered resins offer quiet performance at the lowest cost - 5 choices
- Ball nuts offer positioning accuracy and repeatability with longer life, low-backlash available - 3 choices



## OPTIONS



### AUXILIARY CARRIER **D****C**

- 2X higher Fz (load) capacity
- High bending moment capacity



### TUBE CLAMPS **T****C**

- Used for intermediate support
- Flush with bottom of actuator to retain low profile
- Drop-in, adjustable mounting locations



### MOUNTING PLATES **M****P**

- To provide clearance for motor and mount
- Use in conjunction with tube clamps



### SWITCHES

- Largest number of sensing choices in the industry: Reed, Solid State PNP or NPN, all available normally open or normally closed
- Flush mount, drop-in installation
- Bright LEDs, power & signal indication
- CE rated, RoHS compliant

# ADD YOUR MOTION CONTROL SYSTEM TO THE MXE or

## MRS STEPPER SYSTEM

### STEPPER DRIVE AND CONTROLLER

The **DS** [STAC6-S] & **SI** [STAC6-Si] represent the latest developments in stepper drive technology, incorporating features that derive the highest performance from today's stepper motors. Anti-resonance and waveform damping control algorithms make them the clear market leader.

- Current Output 0.5 to 6.0 A
- 90-135 VAC Input
- 167V Bus
- Set-up and configuration software
- Configurable idle current reduction
- External control options
- Pulse and direction
- Analog Command Signal
- Host command via RS232/485.
- Integral control options -

**Si Programmer™ - intuitive easy-to-use graphical programming language**



### LATEST IN MICROSTEPPING TECHNOLOGY

- **ANTI-RESONANCE**  
Achieves higher speeds and better torque utilization
- **COMMAND SIGNAL SMOOTHING**  
Softens effect of changes in velocity and direction
- **MICROSTEP EMULATION**  
Smooth, high resolution motion across range of speeds
- **SELF-TEST** Measure motor parameters automatically to optimize system performance
- **TORQUE RIPPLE SMOOTHING**  
Adjusts current waveform to reduce low speed torque ripple, providing smoother motion at low speeds

**⚠ Please note the Tolmatic ordering codes. Use these codes when ordering stepper components from Tolmatic**  
(Applied Motion Products model equivalents appear in [brackets])

### STEPPER ACCESSORIES

#### **HUB** MULTI-AXIS MOTION HUB WITH I/O

- Networks Stepper products for multi-axis motion applications.



#### **MMI** OPERATOR INTERFACE

- Allows visual setup of the panel to show a particular action taking place, or to prompt the user to make a decision or provide information such as move distance, move speed, repeat count.



#### **BOB** BREAK OUT BOARD

- Connects the I/O points of the **DS** [STAC6-S] & **SI** [STAC6-Si]



### STEPPER MOTORS

NEMA 23-Frame and 34-Frame MRS Stepper Motors

- Speeds up to 3,000 RPM
- High resolution (up to 51,200 steps per rev)
- Holding torque to 1845 oz-in (13.03 Nm)
- 2000 line Quadrature encoder option
- 10 ft. power cables with connector pre-wired

### HYBRID MOTOR DESIGN

- Designed for increased torque and acceleration rates over a wider speed range

### INDUSTRY STANDARD MOUNTING

- Standard NEMA frame sizes (23 and 34)

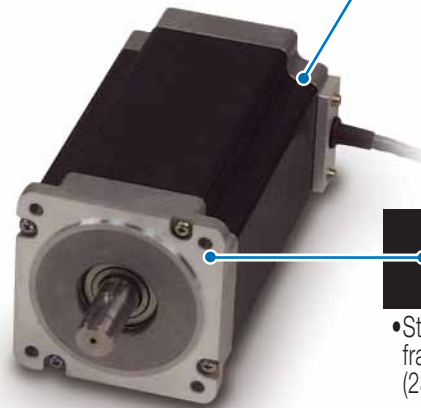



# SELECT A COMPLETE SYSTEM FROM TOLOMATIC

## MRV SERVO SYSTEM

### DIGITAL SERVO DRIVE AND CONTROLLER

Designed by Tolomatic, the Axiom+ PV combines the functions of a servo drive, motion controller and programmable logic controller in a single package. Our all-in-one design eliminates the confusion of multiple software packages, removes discrete wiring or network programming between controllers, and simplifies application programming.

The free Windows®-based software package programs the PLC functions in a standard ladder logic environment and the motion control functions in a simple graphical motion editor.



#### INNOVATIVE SERVO TECHNOLOGY

- **FLUX VECTOR CURRENT CONTROL**  
Provides closed loop motor control of torque producing current by sensing motor current in each individual motor phase. This gives a high bandwidth torque response over the full speed range with high efficiency and minimal phase lag
- **PLUGGABLE SCREW TERMINAL BLOCKS**  
Allows easier termination, quick connection or removal of wiring and direct access to signals for testing with a meter
- **MODBUS RTU COMMUNICATIONS**  
Standard Modbus RTU is built into the drive for communications to other controllers or operator interfaces
- **AMPLIFIER ONLY OPTION**  
The DV version is for use with an external controller that provides analog velocity, analog torque or step commands

#### SPECIFICATIONS:

	PV10	PV20	PV30
Input Line	95 - 250 VAC, 1Ø or 3Ø		
Input Hz	47 - 63 Hz		
Output Current Peak ( $A_{peak}$ )	10	20	30
Output Current Cont ( $A_{cont}$ )	5	10	15
Output Power Cont (kW)	1.4	2.8	4.2
Discrete Inputs	15, optically isolated 5-25VDC		
Discrete Outputs	8, optically isolated 5-25VDC		
Analog Inputs	1, 14-bit Differential $\pm 10$ VDC		

## SERVO MOTORS

The MRV series of brushless servo motors is available in a wide range of torque outputs to meet your demanding applications. These motors are designed for precision motion profiles, low inertia, maximum power density and long continuous life.

#### SPECIFICATIONS:

	TORQUE		Max. Speed (RPM)	Rotor Inertia (lb-in <sup>2</sup> )
	Cont. (lb-in)	Peak (lb-in)		
MRV11	3	12	5000	0.02
MRV21	4	11	6000	0.05
MRV22	8	22	6000	0.10
MRV23	11	33	6000	0.14
MRV24	15	47	6000	0.19
MRV31	17	85	6000	0.38
MRV32	30	150	6000	0.69
MRV33	44	220	6000	1.00
MRV51	80	240	3000	2.53

#### INDUSTRY STANDARD MOUNTING

- Standard NEMA frame sizes (17, 23, 34 and 56)

#### HIGH RESOLUTION ENCODER

- 1000 line quadrature industry standard incremental encoder feedback

#### INTEGRAL PROTECTION

- Thermistor provides over temperature protection
- IP65 rated



# MOMENT AND LOAD CAPACITY

## S SOLID BEARING

### STANDARD CARRIER



SERIES	MAXIMUM BENDING MOMENTS			MAX. LOAD
	Mx	My	Mz	Fz
MXE25S	60 in-lbs	110 in-lbs	34 in-lbs	70 lbf
	6.8 N-m	12.4 N-m	3.8 N-m	289 N
MXE32S	100 in-lbs	350 in-lbs	140 in-lbs	150 lbf
	11.3 N-m	39.5 N-m	15.8 N-m	512 N
MXE40S	275 in-lbs	600 in-lbs	220 in-lbs	225 lbf
	31.1 N-m	67.8 N-m	24.9 N-m	867 N

### DC AUXILIARY CARRIER

SERIES	"D" MIN	MAXIMUM BENDING MOMENTS*			MAX. LOAD
		MxA	MyA	MzA	FzA
MXE25S-DC	6.0 in	120 in-lbs	420 in-lbs	420 in-lbs	140 lbf
	152 mm	13.6 N-m	47.5 N-m	47.5 N-m	623 N
MXE32S-DC	7.0 in	200 in-lbs	1,050 in-lbs	1,050 in-lbs	300 lbf
	178 mm	22.6 N-m	119 N-m	119 N-m	1,335 N
MXE40S-DC	8.5 in	550 in-lbs	1,913 in-lbs	1,913 in-lbs	450 lbf
	216 mm	62.1 N-m	216 N-m	216 N-m	2,002 N

\*At minimum "D" distance see graph on opposite page for complete information



## P PROFILED RAIL

### STANDARD CARRIER



SERIES	MAXIMUM BENDING MOMENTS			MAX. LOAD	
	Mx	My	Mz	Fy	Fz
MXE25P	126 in-lbs	502 in-lbs	377 in-lbs	449 lbf	449 lbf
	14.2 N-m	56.7 N-m	42.6 N-m	1,997 N	1,997 N
MXE32P	226 in-lbs	1,344 in-lbs	1,344 in-lbs	569 lbf	569 lbf
	25.5 N-m	152 N-m	152 N-m	2,531 N	2,531 N
MXE40P	600 in-lbs	1,913 in-lbs	1,913 in-lbs	736 lbf	736 lbf
	67.8 N-m	216 N-m	216 N-m	3,274 N	3,274 N

### DC AUXILIARY CARRIER

SERIES	"D" MIN	MAXIMUM BENDING MOMENTS*			MAX. LOAD	
		MxA	MyA	MzA	FzA	FyA
MXE25P-DC	6.0 in	252 in-lbs	1,613 in-lbs	1,613 in-lbs	898 lbf	898 lbf
	152 mm	28.5 N-m	182 N-m	182 N-m	3,993 N	3,993 N
MXE32P-DC	7.0 in	457 in-lbs	2,202 in-lbs	2,202 in-lbs	1,138 lbf	1,138 lbf
	178 mm	51.6 N-m	249 N-m	249 N-m	5,063 N	5,063 N
MXE40P-DC	8.5 in	1,200 in-lbs	3,601 in-lbs	3,601 in-lbs	1,472 lbf	1,472 lbf
	216 mm	136 N-m	407 N-m	407 N-m	6,549 N	6,549 N

\*At minimum "D" distance see graph on opposite page for complete information

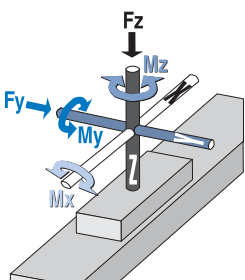

**The above ratings are the maximum values for shock-free, vibration-free operation in a typical industrial environment, which must not be exceeded even in dynamic operation. Contact Tolomatic for assistance in selecting the most appropriate actuator for your application.**

With combined loads,  $L_f$  must not exceed the value 1.

$$L_f = \frac{M_x}{M_{x_{max}}} + \frac{M_y}{M_{y_{max}}} + \frac{M_z}{M_{z_{max}}} + \frac{F_y}{F_{y_{max}}} + \frac{F_z}{F_{z_{max}}} \leq 1$$

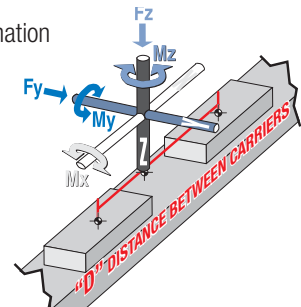

# AUXILIARY CARRIER BENDING MOMENTS

## S SOLID BEARING

(MyA & MzA) vs. DISTANCE

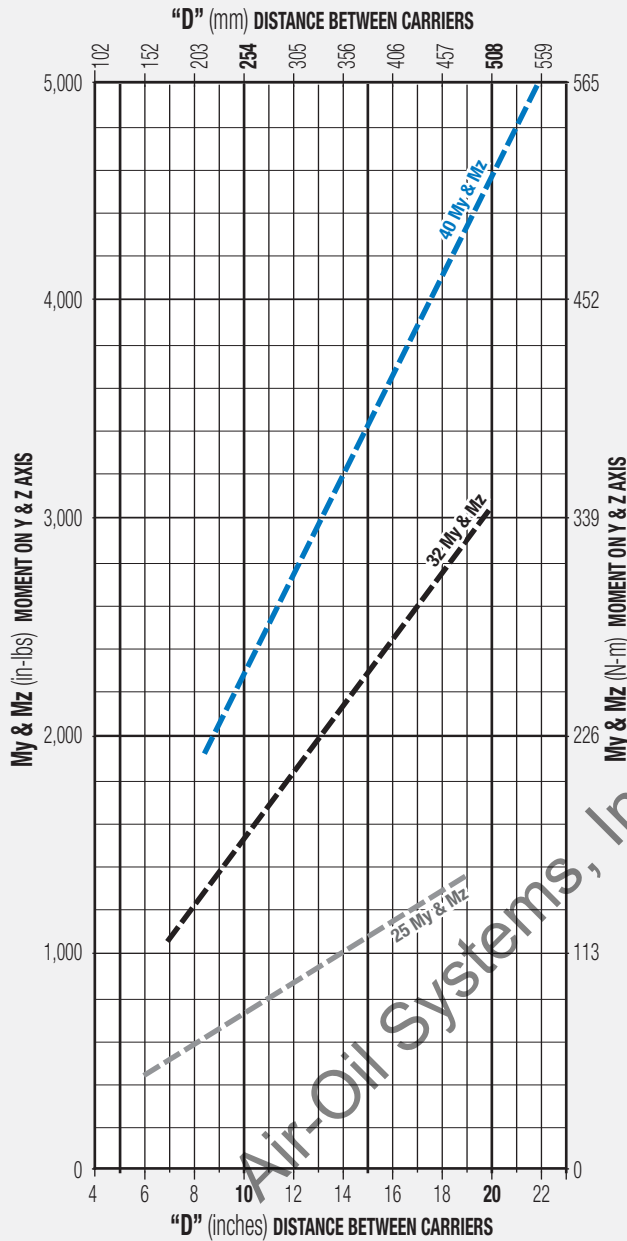

## P PROFILED RAIL

(MyA & MzA) vs. DISTANCE

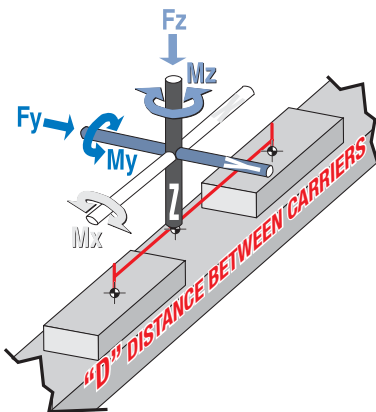
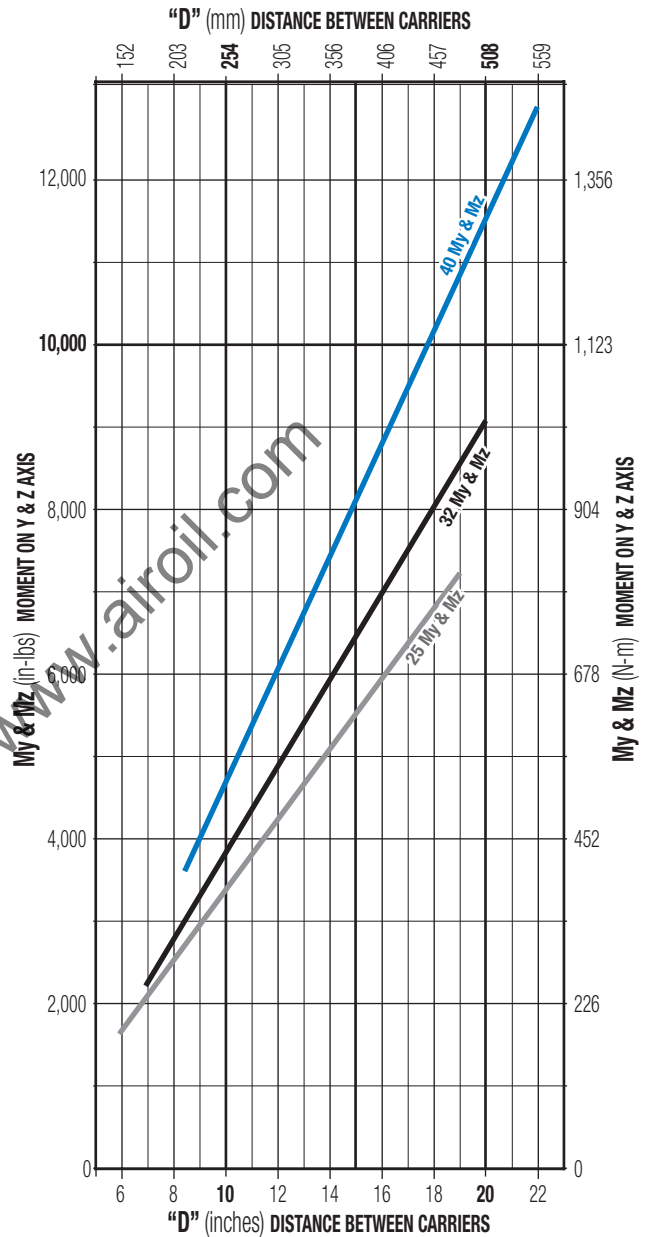

- Ratings were calculated with the following conditions:
- 1.) Coupling between carriers is rigid.
  - 2.) Load is equally distributed between carriers.
  - 3.) Coupling device applies no misalignment loads to carriers.

# ACTUATOR AND SCREW SPECIFICATIONS

## GENERAL ACTUATOR SPECIFICATIONS

ACTUATOR SERIES	CARRIER WEIGHT (including nut bracket assembly)				BASE ACTUATOR WEIGHT (excluding nut bracket and carrier assembly)				WEIGHT PER INCH OF STROKE				TEMPERATURE RANGE		IP RATING*
	S SOLID		P PROFILED		S SOLID		P PROFILED		S SOLID		P PROFILED		F	C	
	LB	KG	LB	KG	LB	KG	LB	KG	LB	KG	LB	KG			
<b>MXE25</b>	0.91	0.41	1.02	0.46	2.11	0.96	2.44	1.11	0.19	0.09	0.25	0.12	40-130	4-54	44
<b>MXE32</b>	1.74	0.79	2.12	0.96	2.74	1.24	3.30	1.50	0.29	0.13	0.37	0.17	40-130	4-55	44
<b>MXE40</b>	3.15	1.43	3.72	1.69	5.34	2.42	6.88	3.12	0.40	0.18	0.58	0.26	40-130	4-55	44

\* Approximately equivalent to the requirements of IP44 (protected against ingress of solid particles greater than .039 in (1 mm) and splashing water)

## FRICITION FORCE

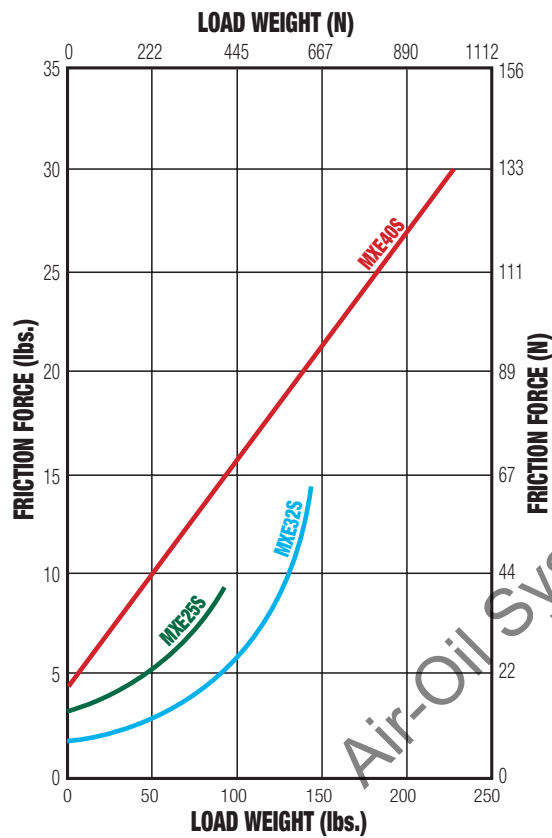

## BREAKAWAY TORQUE

ACTUATOR SERIES	SCREW DIAMETER		SCREW TYPE	SCREW PITCH REV/IN	BREAKAWAY TORQUE			
	IN	MM			SINGLE CARRIER		AUXILIARY CARRIER	
				OZ-IN	N-M	OZ-IN	N-M	
<b>MXE25</b>	0.375	9.53	BN	08	16	0.113	18	0.127
	0.375	9.53	BNL	08	16	0.113	18	0.127
	0.500	12.70	SN	01	30	0.212	46	0.325
	0.500	12.70	SN	02	25	0.177	35	0.247
	0.500	12.70	SN	05	18	0.127	22	0.155
<b>MXE32</b>	0.375	9.53	BN	08	16	0.113	18	0.127
	0.375	9.53	BNL	08	16	0.113	18	0.127
	0.500	12.70	SN	01	30	0.212	46	0.325
	0.500	12.70	SN	02	25	0.177	35	0.247
	0.500	12.70	SN	05	18	0.127	22	0.155
<b>MXE40</b>	0.500	12.70	BN	02	28	0.198	35	0.247
	0.500	12.70	BNL	02	28	0.198	35	0.247
	0.625	15.88	BN	05	35	0.247	45	0.318
	0.625	15.88	BNL	05	35	0.247	45	0.318
	0.625	15.88	SN	02	35	0.245	44	0.311
	0.750	19.05	SN	01	50	0.353	72	0.508
	0.750	19.05	SN	01	50	0.353	72	0.508

# ACTUATOR SCREW, INERTIA AND BREAKAWAY TORQUE

## SCREW SPECIFICATIONS

ACTUATOR SERIES	SCREW DIAMETER		SCREW TYPE	SCREW PITCH REV/IN	SCREW LEAD		LEAD ACCURACY		BACKLASH		MAX THRUST		MAX STROKE	
	IN	MM			IN	MM	IN/FT	MM/300MM	IN	MM	LB	N	IN	MM
MXE25	0.375	9.53	BN	08	0.13	3.18	.004	0.10	.015	0.38	130	578	61	1549
	0.375	9.53	BNL	08	0.13	3.18	.004	0.10	.002	0.05	130	578	61	1549
	0.500	12.70	SN	01	1.00	25.40	.006	0.15	.007	0.18	170	756	85	2159
	0.500	12.70	SN	02	0.50	12.70	.005	0.13	.003	0.08	170	756	120	3048
	0.500	12.70	SN	05	0.20	5.08	.006	0.15	.007	0.18	170	756	120	3048
	0.375	9.53	BN	08	0.13	3.18	.004	0.10	.015	0.38	130	578	61	1549
MXE32	0.375	9.53	BNL	08	0.13	3.18	.004	0.10	.002	0.05	130	578	61	1549
	0.500	12.70	SN	01	1.00	25.40	.006	0.15	.007	0.18	170	756	85	2159
	0.500	12.70	SN	02	0.50	12.70	.005	0.13	.003	0.08	170	756	120	3048
	0.500	12.70	SN	05	0.20	5.08	.006	0.15	.007	0.18	170	756	120	3048
MXE40	0.500	12.70	BN	02	0.50	12.70	.003	0.08	.015	0.38	800	3559	59	1499
	0.500	12.70	BNL	02	0.50	12.70	.003	0.08	.002	0.05	800	3559	59	1499
	0.625	15.88	BN	05	0.20	5.08	.003	0.08	.015	0.38	800	3559	59	1499
	0.625	15.88	BNL	05	0.20	5.08	.003	0.08	.002	0.05	800	3559	59	1499
	0.625	15.88	SN	02	0.50	12.70	.005	0.13	.007	0.18	200	890	120	3048
	0.750	19.05	SN	01	1.00	25.40	.005	0.13	.007	0.18	300	1334	120	3048

## REFLECTED INERTIA

ACTUATOR SERIES	SCREW DIAMETER		SCREW TYPE	SCREW PITCH REV/IN	REFLECTED INERTIA										PER IN OF STROKE			
					BASE ACTUATOR													
					SOLID				PROFILED									
					IN-LINE		REV PARALLEL		IN-LINE		REV PARALLEL		IN-LINE				REV PARALLEL	
IN	MM	LB-IN <sup>2</sup>	KG-CM <sup>2</sup>	LB-IN <sup>2</sup>	KG-CM <sup>2</sup>	LB-IN <sup>2</sup>	KG-CM <sup>2</sup>	LB-IN <sup>2</sup>	KG-CM <sup>2</sup>	LB-IN <sup>2</sup>	KG-CM <sup>2</sup>	LB-IN <sup>2</sup>	KG-CM <sup>2</sup>					
MXE25	0.375	9.53	BN	08	0.0062	0.0182	0.0062	0.0182	0.0063	0.0183	0.0063	0.0183	0.0005	0.0015				
	0.375	9.53	BNL	08	0.0062	0.0182	0.0062	0.018	0.0063	0.0183	0.0063	0.0183	0.0005	0.0015				
	0.500	12.70	SN	01	0.0498	0.1456	0.0498	0.1456	0.0541	0.1583	0.0541	0.1583	0.0017	0.0050				
	0.500	12.70	SN	02	0.0213	0.0623	0.0213	0.0623	0.0224	0.0654	0.0224	0.0654	0.0017	0.0050				
	0.500	12.70	SN	05	0.0133	0.0390	0.0133	0.0390	0.0135	0.0395	0.0135	0.0395	0.0017	0.0050				
	0.375	9.53	BN	08	0.0066	0.0193	0.0066	0.0193	0.0068	0.0198	0.0068	0.0198	0.0005	0.0015				
MXE32	0.375	9.53	BNL	08	0.0066	0.0193	0.0066	0.0193	0.0068	0.0198	0.0068	0.0198	0.0005	0.0015				
	0.500	12.70	SN	01	0.0832	0.2436	0.0842	0.2465	0.1005	0.2940	0.1015	0.2969	0.0017	0.0050				
	0.500	12.70	SN	02	0.0296	0.0868	0.0306	0.0897	0.0340	0.0994	0.0350	0.1023	0.0017	0.0050				
	0.500	12.70	SN	05	0.0147	0.0429	0.0157	0.0458	0.0153	0.0449	0.0163	0.0478	0.0017	0.0050				
MXE40	0.500	12.70	BN	02	0.0502	0.1468	0.0502	0.1470	0.0544	0.1593	0.0545	0.1594	0.0017	0.0050				
	0.500	12.70	BNL	02	0.0502	0.1480	0.0512	0.1497	0.0544	0.1593	0.0545	0.1594	0.0017	0.0050				
	0.625	15.88	BN	05	0.0506	0.1480	0.0512	0.1497	0.0512	0.1500	0.0518	0.1517	0.0042	0.0123				
	0.625	15.88	BNL	05	0.0506	0.1480	0.0512	0.1497	0.0512	0.1500	0.0518	0.1517	0.0042	0.0123				
	0.625	15.88	SN	02	0.0781	0.2286	0.0787	0.2304	0.0842	0.2463	0.0848	0.2480	0.0042	0.0123				
	0.750	19.05	SN	01	0.2035	0.5956	0.2041	0.5973	0.2276	0.6661	0.2282	0.6679	0.0087	0.0255				

# TUBE CLAMP REQUIREMENTS

## S SOLID BEARING

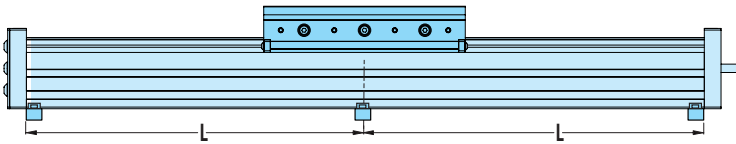
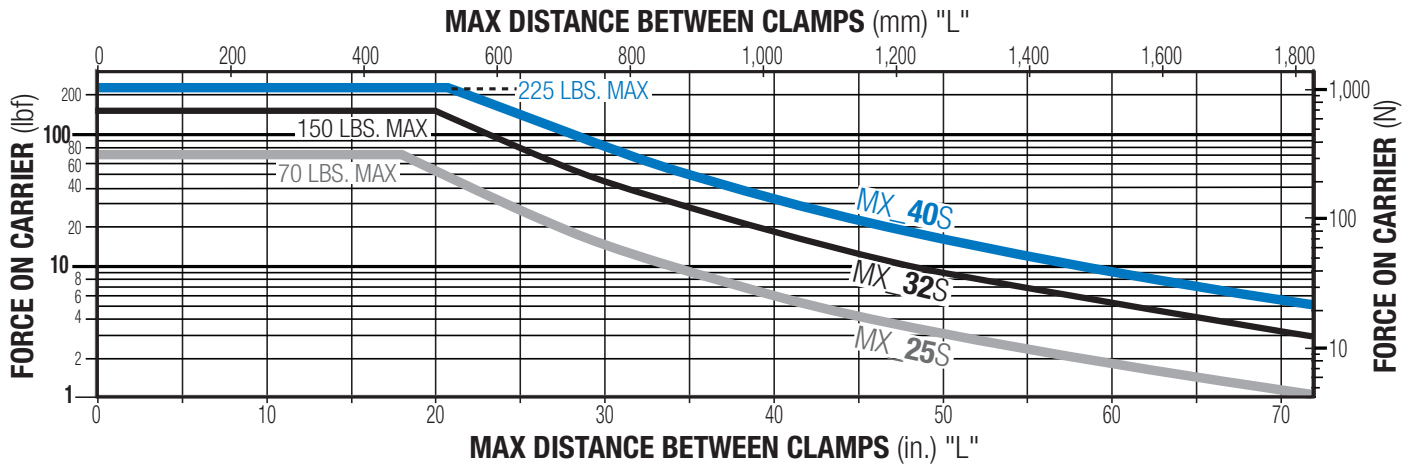

## P PROFILED RAIL BEARING

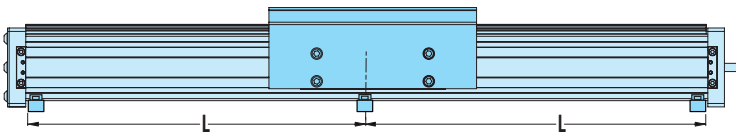
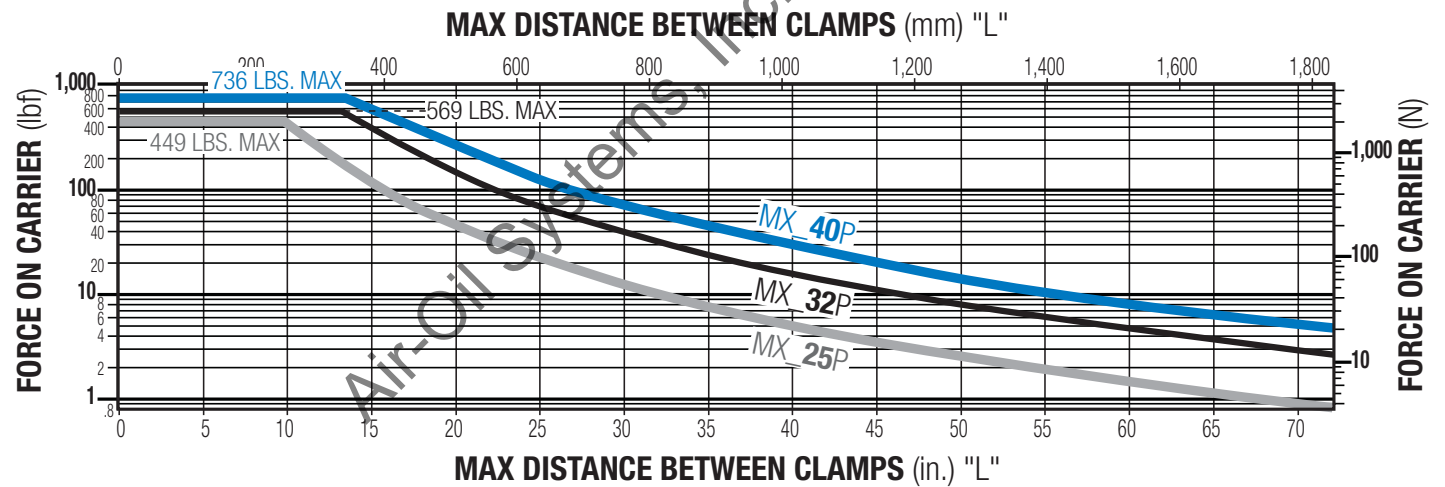

# SCREW CRITICAL SPEED CAPACITIES

## MXE ACME SCREW CRITICAL SPEED

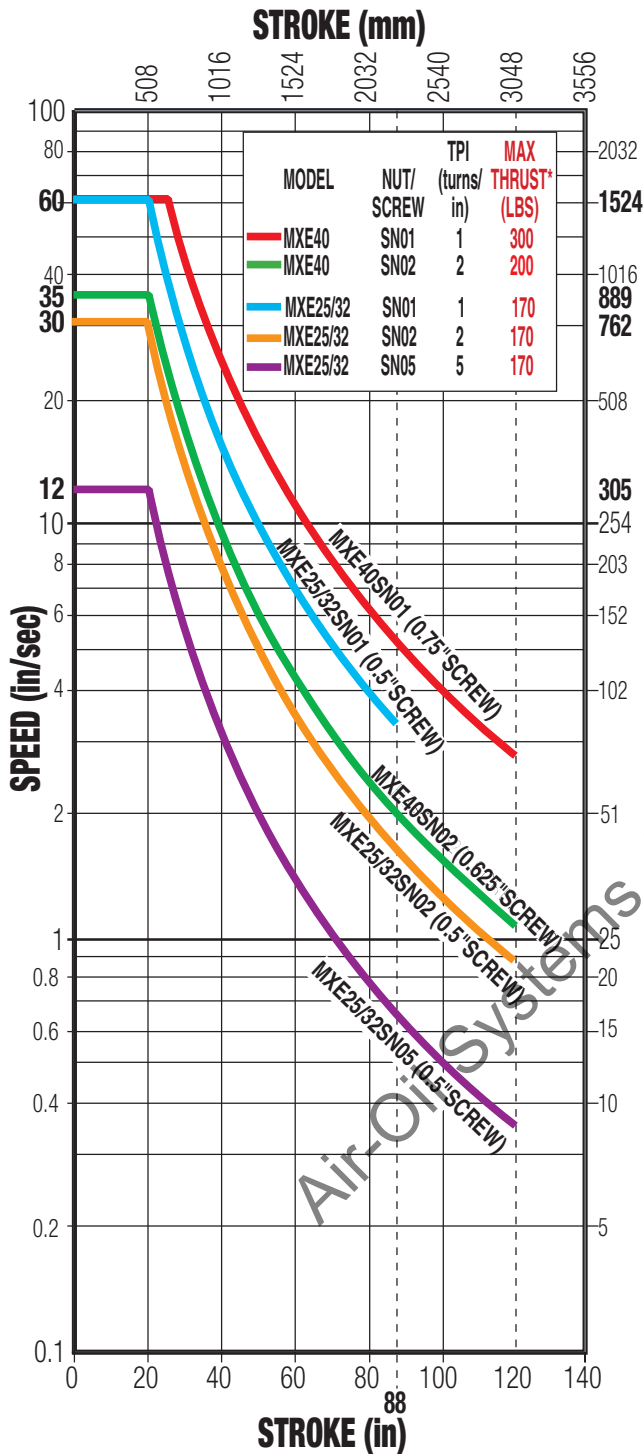

## MXE BALL SCREW CRITICAL SPEED

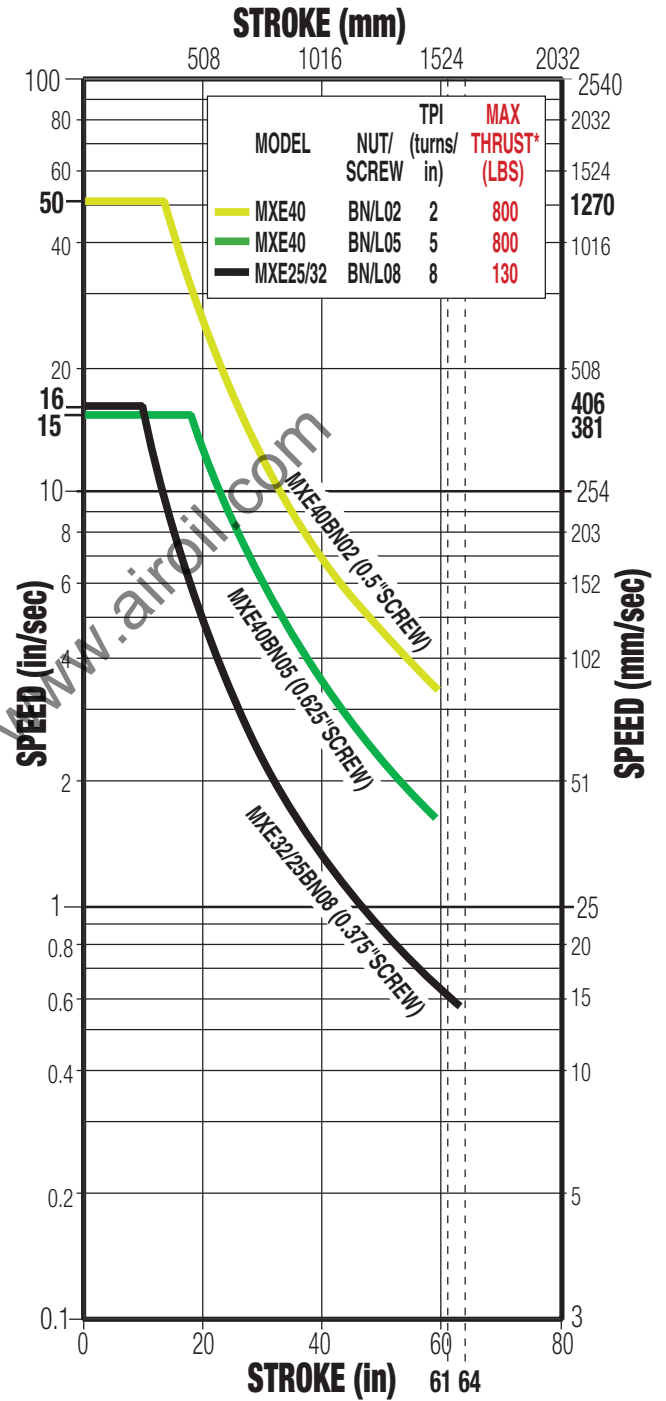

\* Maximum thrust is the maximum continuous dynamic thrust subject to Thrust x Velocity limitation.

Dotted lines represent maximum stroke for screw selections.

For Screw PV limits, refer to the individual charts located in the technical selection for each actuator body size.

SCREW CODE	DESCRIPTION
SN	Solid Nut
BN	Ball Nut
BNL	Low Backlash Ball Nut

# MXE25/32 ACME SCREW CRITICAL SPEED AND PV LIMITS

## Critical Speed: 0.5" ACME

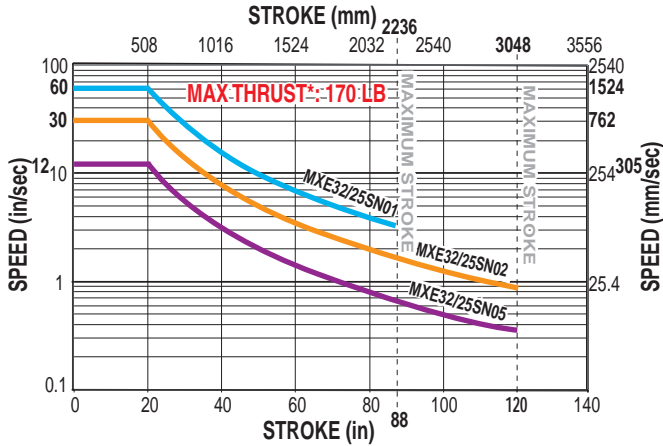

## PV Limits: 1TPI Acme Screw

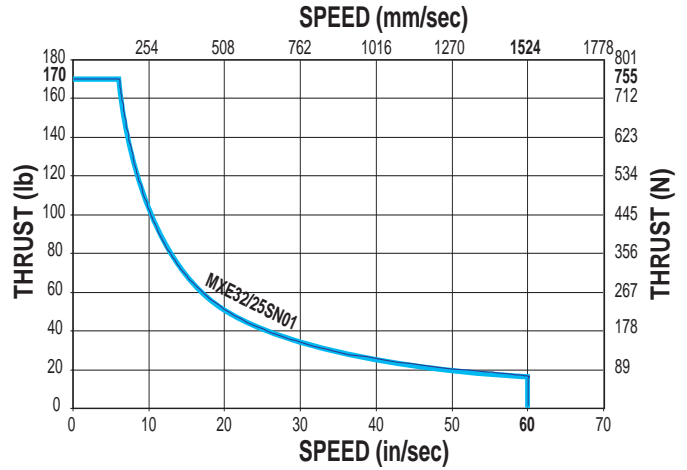

## PV Limits: 2TPI Acme Screw

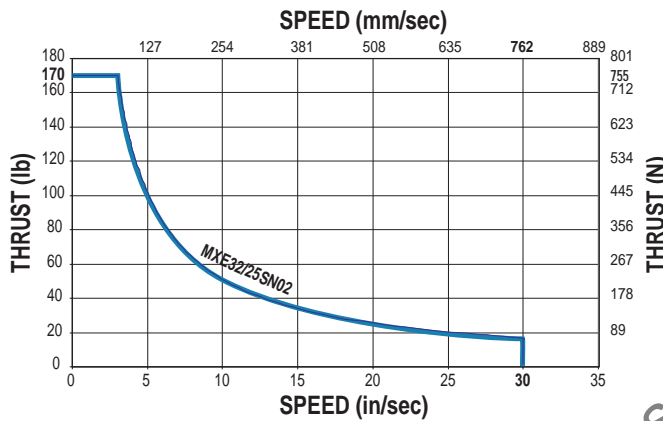

## PV Limits: 5TPI Acme Screw

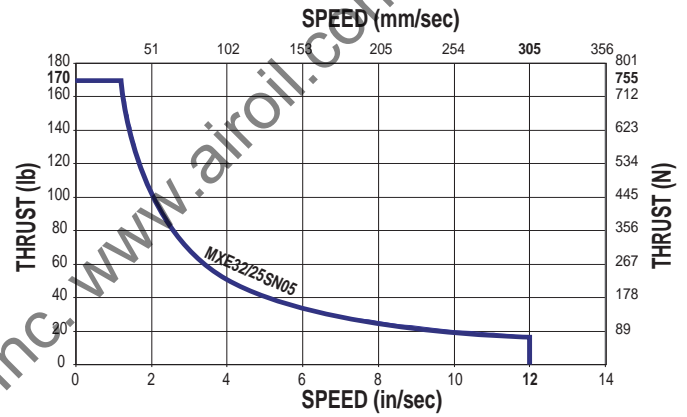

SN = Solid Nut

**A** \* Maximum thrust is the maximum continuous dynamic thrust subject to Thrust x Velocity Limitation.

**PV LIMITS:** Any material which carries a sliding load is limited by heat buildup. The factors that affect heat generation rate in an application are the pressure on the nut in pounds per square inch and the surface velocity in feet per minute. The product of these factors provides a measure of the severity of an application.

$$P = \frac{\text{Thrust}}{\text{Max. Thrust Rating}} \times V = \frac{\text{Speed}}{\text{Max. Speed Rating}} \leq 0.1$$

Air Oil Systems, Inc www.airoil.com



# MXE25/32 BALL SCREW CRITICAL SPEED AND LIFE CALCULATIONS

Critical Speed: 0.375", 8TPI Ball Screw

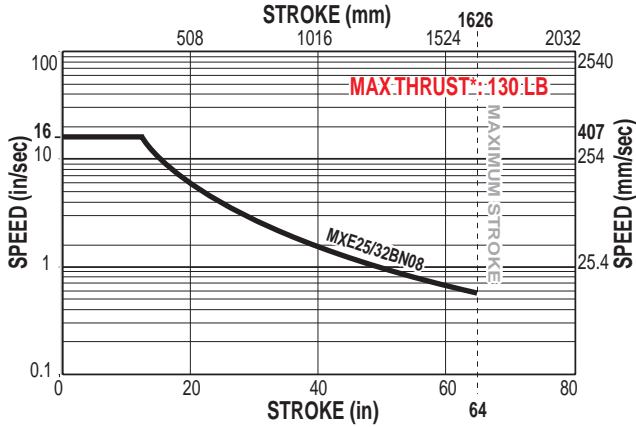

Life: 0.375", 8TPI Ball Screw

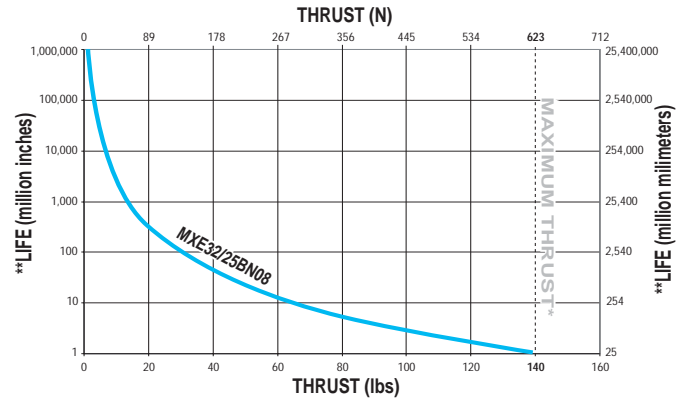

BN = Ball Nut

**⚠** \*Maximum thrust reflects 90% reliability for 1 million linear inches of travel.

\*\*Life indicates theoretical maximum life of screw only, under ideal conditions and does not indicate expected life of actuator.

Air-Oil Systems, Inc. www.airoil.com

# MXE40 ACME SCREW CRITICAL SPEED AND PV LIMITS

**Critical Speed: 0.75" 1TPI Acme Screw**

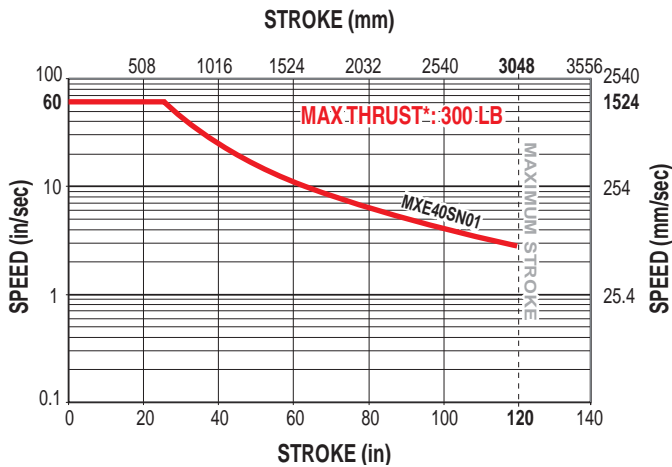

**Critical Speed: 0.625" 2TPI Acme Screw**

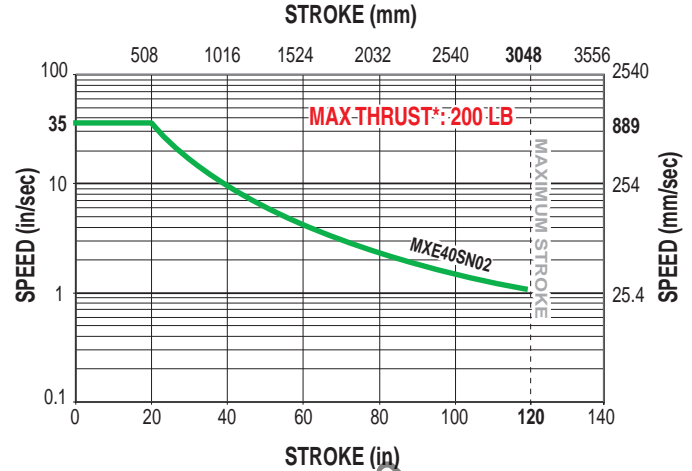

**PV Limits: 1TPI Acme Screw**

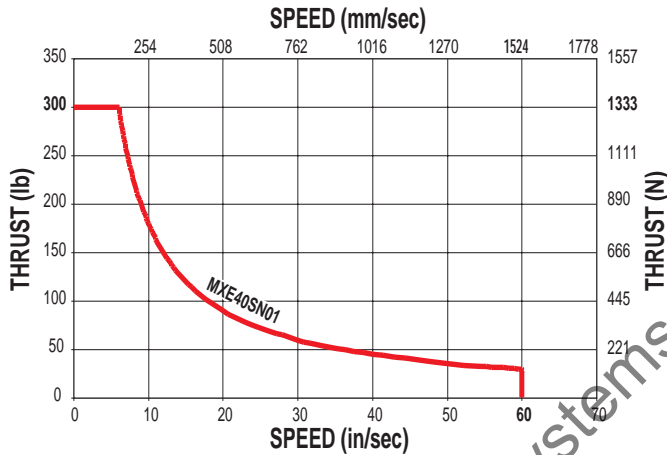

**PV Limits: 2TPI Acme Screw**

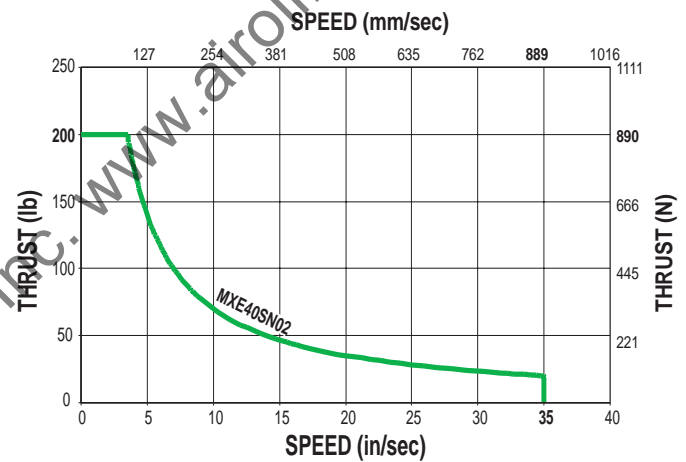

SN = Solid Nut

**⚠** \* Maximum thrust is the maximum continuous dynamic thrust subject to Thrust x Velocity Limitation.

**PV LIMITS:** Any material which carries a sliding load is limited by heat buildup. The factors that affect heat generation rate in an application are the pressure on the nut in pounds per square inch and the surface velocity in feet per minute. The product of these factors provides a measure of the severity of an application.

$$P = \frac{\text{Thrust}}{\text{Max. Thrust Rating}} \times V = \frac{\text{Speed}}{\text{Max. Speed Rating}} \leq 0.1$$

# MXE40 BALL SCREW CRITICAL SPEED AND LIFE CALCULATIONS

**Critical Speed: 0.5", 2TPI Ball Screw**

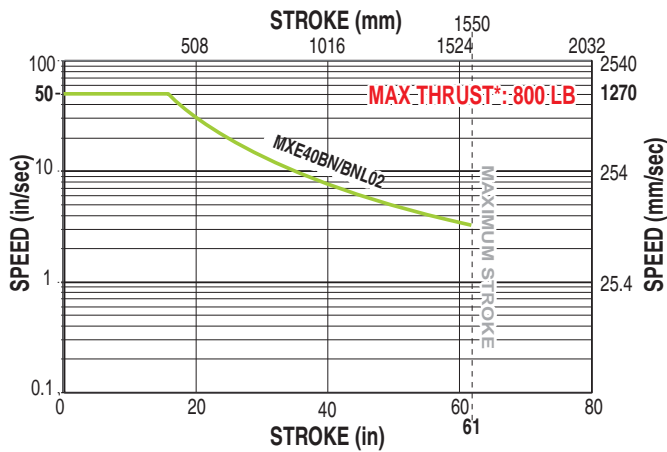

**Critical Speed: 0.625", 5TPI Ball Screw**

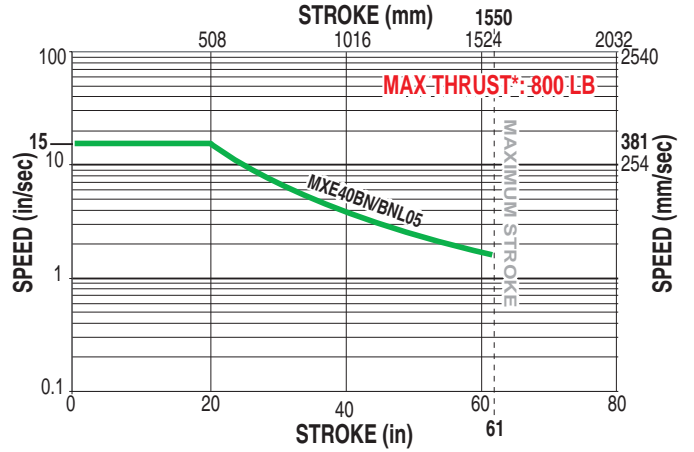

**Life: 0.5" and 0.625" Ball Screws**

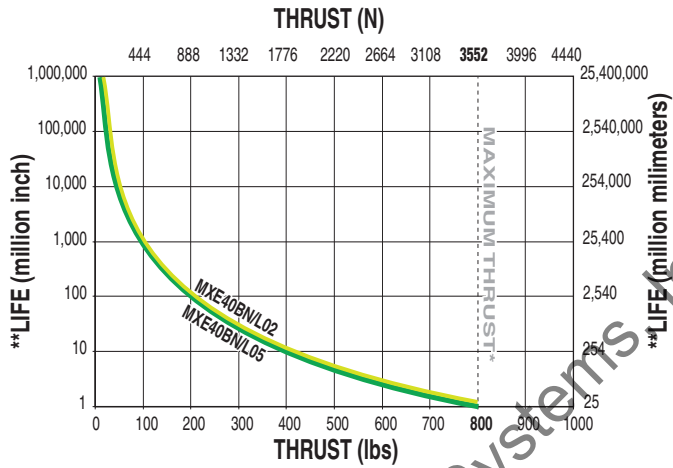

**BN = Ball Nut**

**▲** \*Maximum thrust reflects 90% reliability for 1 million linear inches of travel.

\*\*Life indicates theoretical maximum life of screw only, under ideal conditions and does not indicate expected life of actuator.

# S-SOLID BEARING ACTUATOR DIMENSIONS

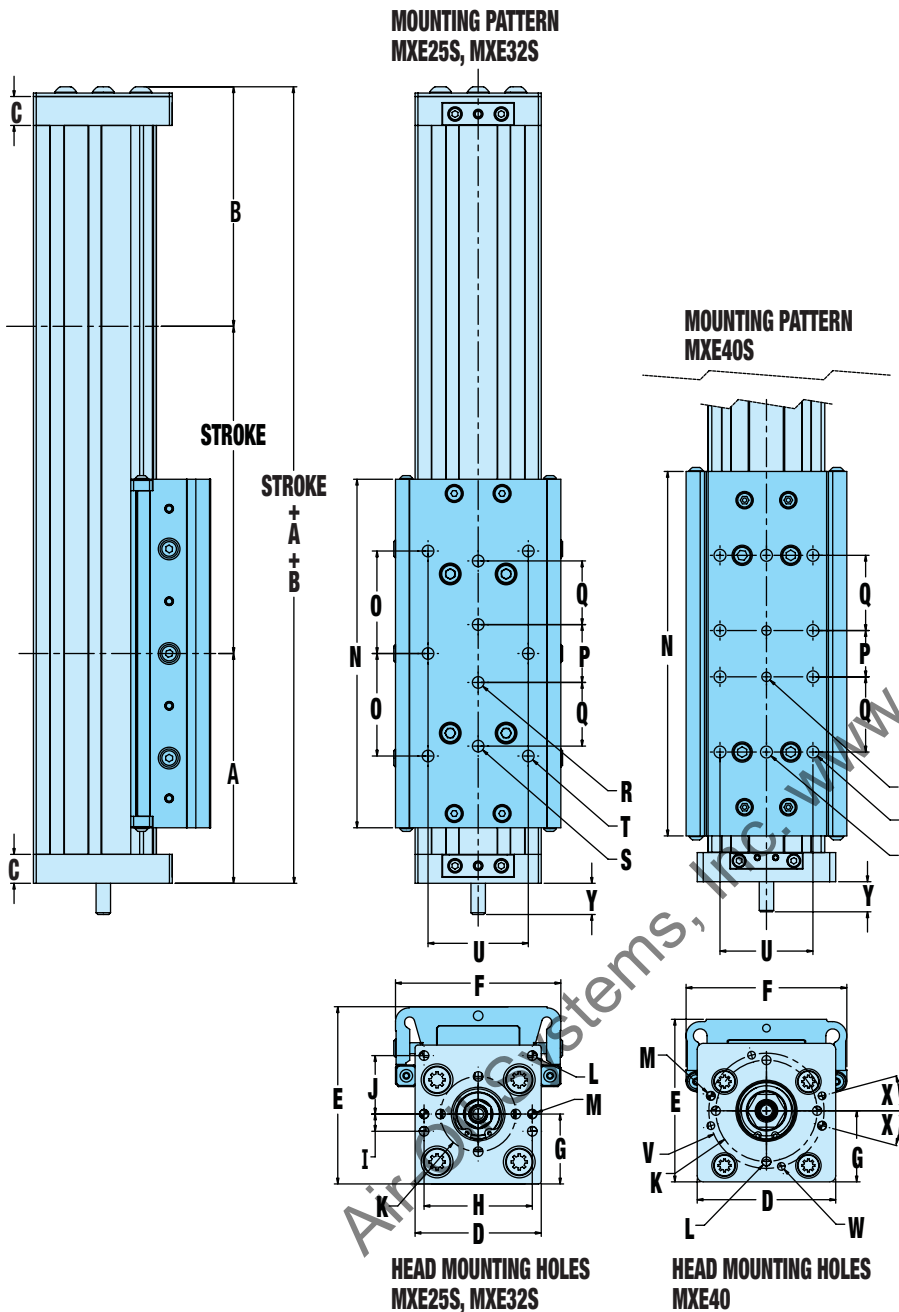

	MXE25S	MXE32S	MXE40S
A	3.79	3.97	4.93
mm	96.3	100.9	125.2
B	3.96	4.14	5.12
mm	100.6	105.1	130.0
C	0.92	0.50	0.63
mm	23.4	12.7	16.0
D	2.25	2.18	2.99
mm	57.2	55.4	75.9
E	2.30	3.06	3.51
mm	58.4	77.8	89.2
F	2.18	2.86	3.47
mm	55.4	72.6	88.2
G	0.95	1.21	1.54
mm	24.1	30.7	39.1
H	1.87	1.87	-
mm	47.5	47.5	-
I	0.80	0.30	-
mm	7.6	7.6	-
J	1.01	1.01	-
mm	25.7	25.7	-
K	Ø1.30	Ø1.30	Ø2.19
mm	Ø33.0	Ø33.0	Ø55.6
L	M5x0.8 (8)	M5x0.8 (8)	M6x1.0 (4)
mm	M5x0.8 (8)	M5x0.8 (8)	M6x1.0 (4)
M	0.158	0.158	0.189
mm	4.01	4.01	4.80
N	5.31	6.02	7.87
mm	134.9	153.0	200.0
O	1.57	1.77	-
mm	39.9	45.0	-
P	1.00	1.00	1.00
mm	25.4	25.4	25.4
Q	1.07	1.10	1.63
mm	27.2	28.0	41.3
R	1/4-20 (2)	1/4-20 (2)	1/4-20 (2)
mm	M6x1.0 (2)	M8x1.25 (2)	M8x1.25 (2)
S	#10-32 (2)	1/4-20 (2)	5/16-18 (2)
mm	M6x1.0 (2)	M8x1.25 (2)	M8x1.25 (2)
T	1/4-20 (6)	1/4-20 (6)	5/16-18 (8)
mm	M6x1.0 (6)	M8x1.25 (6)	M8x1.25 (8)
U	1.18	1.73	2.00
mm	30.0	44.0	51.0
V	-	-	Ø2.49
mm	-	-	Ø63.2
W	-	-	M5x0.8 (4)
mm	-	-	M5x0.8 (4)
X	-	-	15°
mm	-	-	15°
Y	MXE25	MXE32	MXE40
LMI	0.55	0.55	0.69
mm	14.0	14.0	17.5
23 FRAME RP	1.99	1.99	1.99
mm	50.5	50.5	50.5
34 FRAME RP	2.20	2.20	2.20
mm	55.9	55.9	55.9

# S-SOLID BEARING OPTION DIMENSIONS

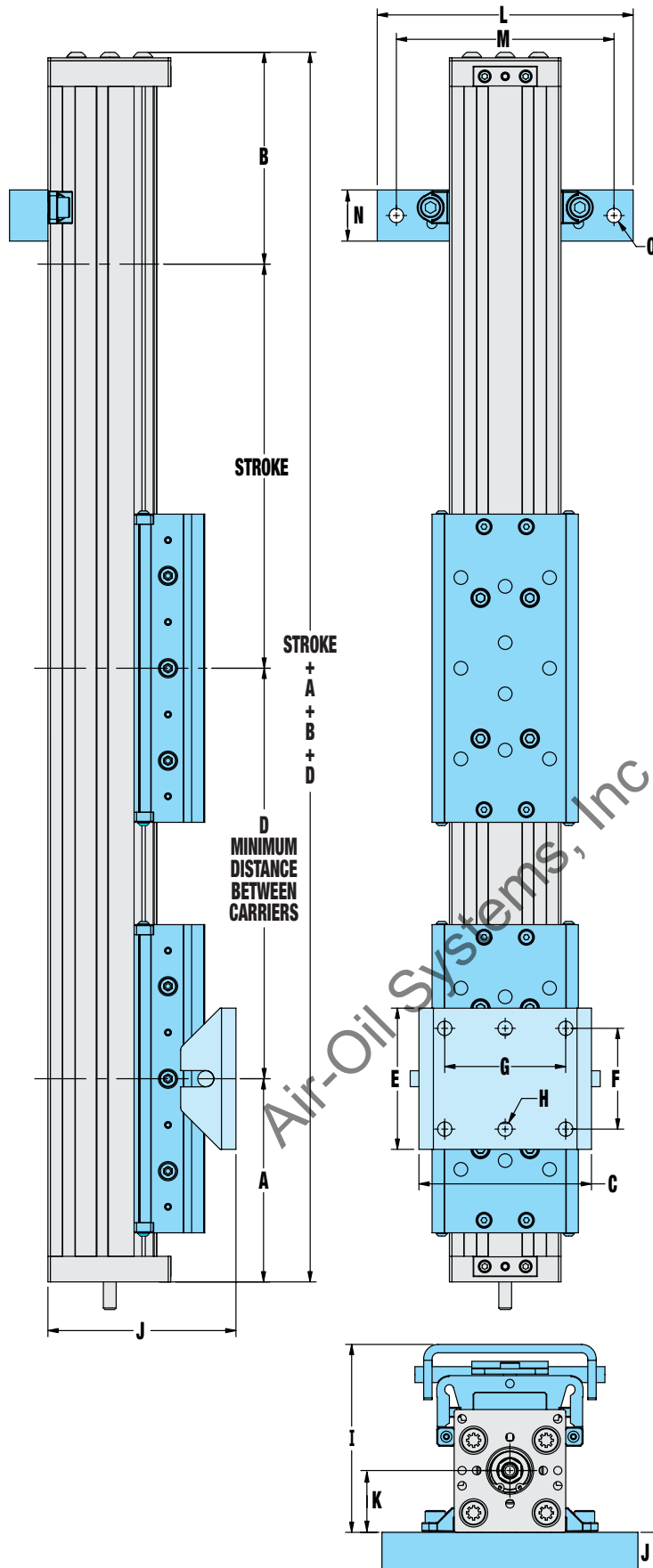

	<b>MXE25S</b>	<b>MXE32S</b>	<b>MXE40S</b>
A	3.79	3.97	4.93
mm	96.3	100.9	125.2
B	3.96	4.14	5.12
mm	100.6	105.1	130.0
<b>AUXILIARY CARRIER</b>			
D	6.00	7.00	8.50
mm	152.4	177.8	215.9
<b>FLOATING MOUNT</b>			
C	2.52	3.37	4.32
mm	64.1	93.3	109.7
E	1.25	2.76	3.94
mm	31.8	70.1	100.0
F	0.63	1.97	2.95
mm	15.9	50	74.9
G	-	-	2.17
mm	-	-	55.1
H*	0.24 (2)	0.28 (2)	0.28 (4)
mm	6.1 (2)	7.1 (2)	7.1 (4)
I	2.80	3.67	4.26
mm	71.0	93.3	108.2
<b>MOUNTING PLATE/TUBE CLAMP KITS</b>			
J**	1.00	0.75	0.63
mm	25.4	19.1	16.0
J***	1.38	1.13	1.00
mm	35.1	28.7	25.4
K	0.95	1.21	1.54
mm	24.1	30.7	39.1
L	4.00	5.00	5.00
mm	101.6	127.0	127.0
M	3.69	4.63	4.41
mm	93.8	117.5	112.0
N	1.00	1.00	0.79
mm	25.4	25.4	20.0
O	0.22 (2)	0.28 (2)	0.28 (2)
mm	5.6 (2)	7.1 (2)	7.1 (2)

\* MXE25 & MXE32 USE 2 CENTER HOLES, MXP40 USES 4 CORNER HOLES

\*\* MOUNTING PLATE THICKNESS FOR 23 FRAME MOTORS

\*\*\* MOUNTING PLATE THICKNESS FOR 34 FRAME MOTORS

# P-PROFILED RAIL ACTUATOR DIMENSIONS

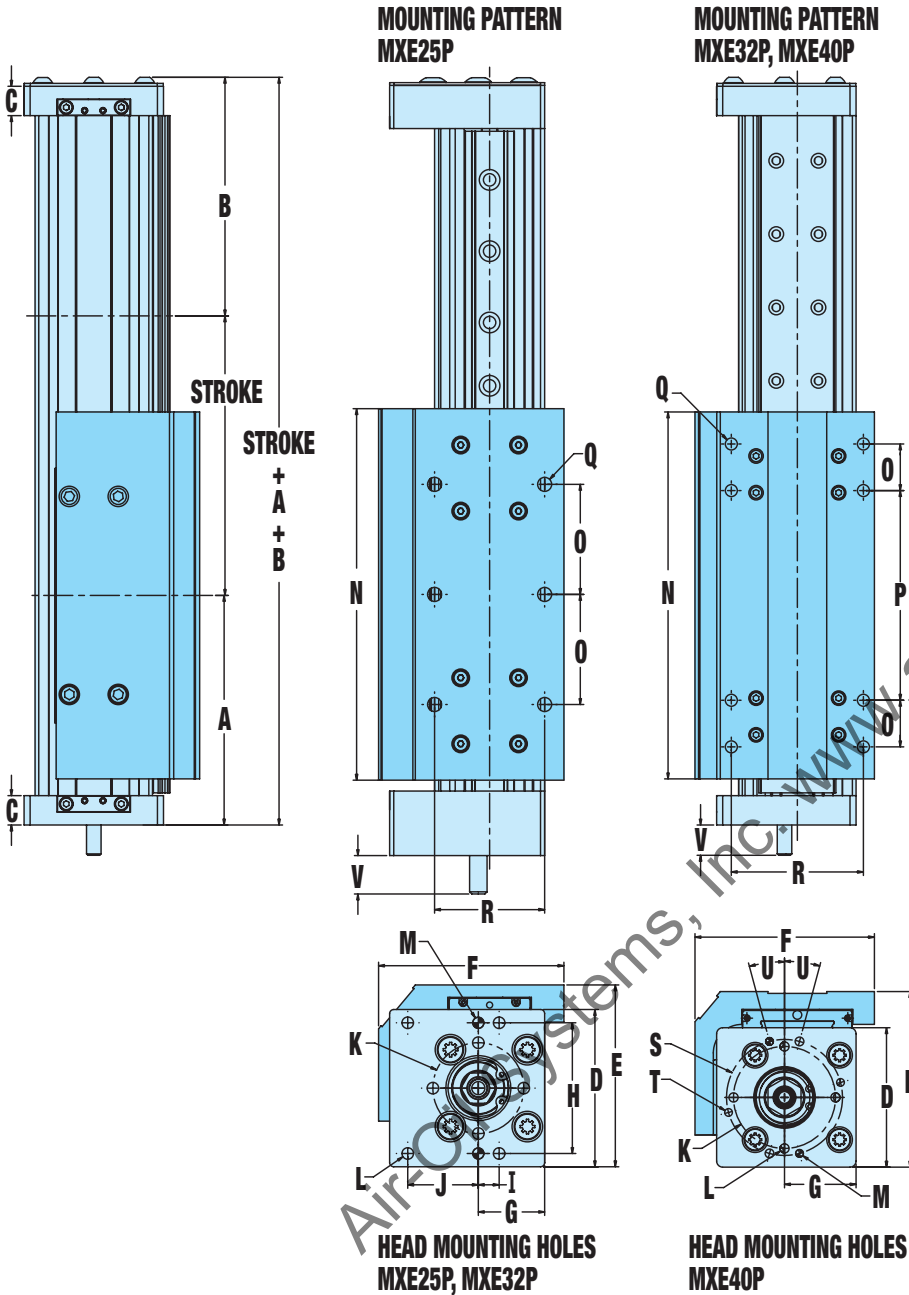

	MXE25P	MXE32P	MXE40P
A	3.79	3.97	4.93
mm	96.3	100.9	125.2
B	3.96	4.14	5.12
mm	100.6	105.1	130.0
C	0.92	0.50	0.63
mm	23.4	12.7	16.0
D	2.25	2.18	2.99
mm	57.2	55.4	75.9
E	2.6	3.05	3.77
mm	66.1	77.4	95.7
F	2.65	3.25	3.85
mm	67.4	82.6	97.8
G	0.95	1.21	1.54
mm	24.1	30.7	39.1
H	1.87	1.87	-
mm	4.5	47.5	-
I	0.30	0.30	-
mm	7.6	7.6	-
J	1.01	1.01	-
mm	25.7	25.7	-
K	Ø1.30	Ø1.30	Ø2.19
mm	Ø33.0	Ø33.0	Ø55.6
L	M5X0.8 (8)	M5X0.8 (8)	M6X1.0 (4)
mm	M5X0.8 (8)	M5X0.8 (8)	M6X1.0 (4)
M	0.158	0.158	0.189
mm	4.01	4.01	4.80
N	5.31	6.69	7.87
mm	135.0	170.0	200
O	1.57	1.07	1.00
mm	40.0	27.2	25.4
P	-	3.37	4.50
mm	-	85.6	114.3
Q	1/4-20 (6)	5/16-18 (8)	5/16-18 (8)
mm	M6X1.0 (6)	M8X1.25 (8)	M8X1.25 (8)
R	1.57	1.97	2.84
mm	40.0	50.0	72.1
S	-	-	Ø2.49
mm	-	-	Ø63.2
T	-	-	M5X0.8 (4)
mm	-	-	M5X0.8 (4)
U	-	-	15°
mm	-	-	15°
V			
	MXE25	MXE32	MXE40
LMI	0.55	0.55	0.69
mm	14.0	14.0	17.5
23 FRAME RP	1.99	1.99	1.99
mm	50.5	50.5	50.5
34 FRAME RP	2.20	2.20	2.20
mm	55.9	55.9	55.9

# P-PROFILED RAIL OPTION DIMENSIONS

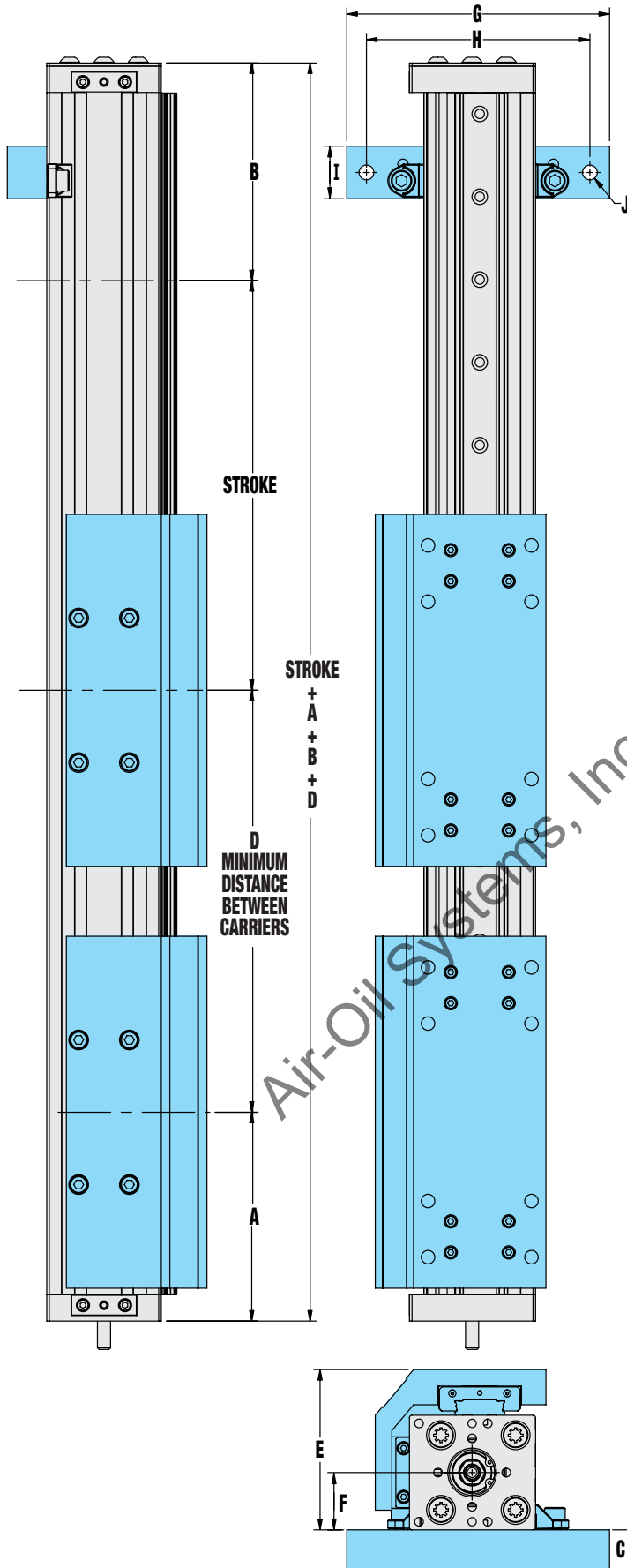

	<b>MXE25P</b>	<b>MXE32P</b>	<b>MXE40P</b>
A	3.79	3.97	4.93
mm	96.3	100.9	125.2
B	3.96	4.14	5.12
mm	100.6	105.1	130.0
<b>AUXILIARY CARRIER</b>			
D	6.00	7.00	8.50
mm	152.4	177.8	215.9
<b>MOUNTING PLATE/TUBE CLAMP KITS</b>			
C*	1.00	0.75	0.63
mm	25.4	19.1	16.0
C**	1.38	1.13	1.00
mm	35.1	28.7	25.4
E	2.60	3.05	3.77
mm	66.1	77.4	95.7
F	1.13	1.09	1.50
mm	28.7	27.7	38.1
G	4.00	5.00	5.00
mm	101.6	127.0	127.0
H	3.69	4.63	4.41
mm	93.8	117.5	112.0
I	1.00	1.00	0.79
mm	25.4	25.4	20.0
J	0.22 (2)	0.28 (2)	0.28 (2)
mm	5.6 (2)	7.1 (2)	7.1 (2)

\* MOUNTING PLATE THICKNESS FOR 23 FRAME MOTORS

\*\* MOUNTING PLATE THICKNESS FOR 34 FRAME MOTORS

# S-SOLID BEARING AND P-PROFILED RAIL IN-LINE MOTOR MOUNTING

MXE25/32

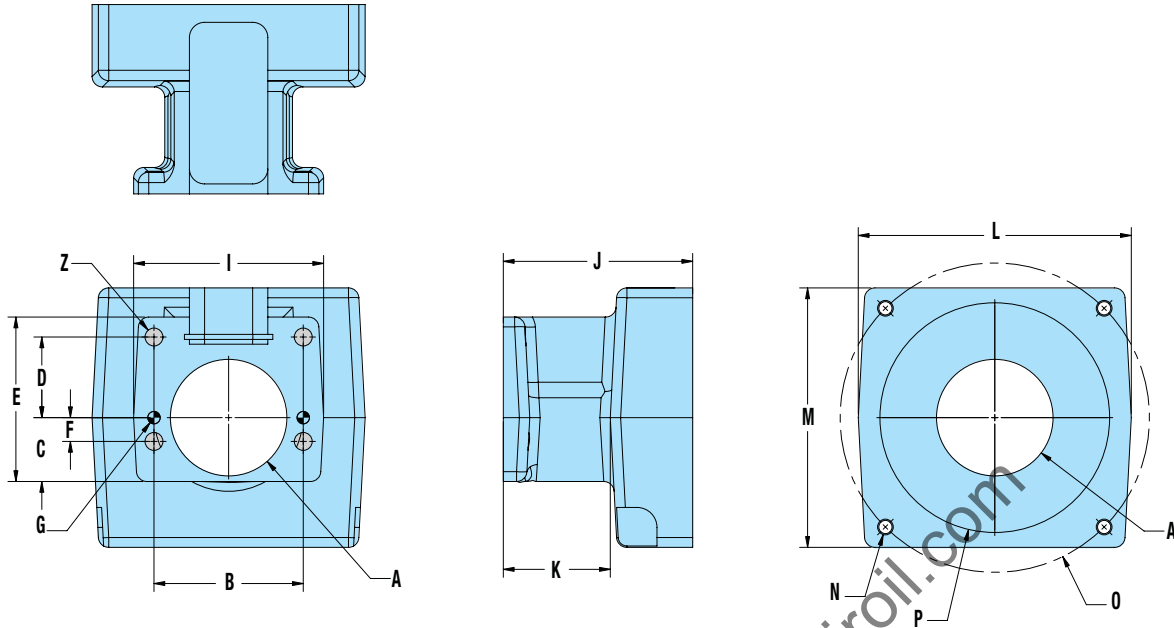

	MRV2x	MRS2x	MRS3x
A	Ø1.46	Ø1.46	Ø1.46
mm	Ø37.1	Ø37.1	Ø37.1
B	1.870	1.870	1.870
mm	47.50	47.50	47.50
C	.800	.800	.800
mm	20.32	20.32	20.32
D	1.010	1.010	1.010
mm	25.65	25.65	25.65
E	2.06	2.06	2.06
mm	52.3	52.3	52.3
F	.298	.298	.298
mm	7.57	7.57	7.57
G	Ø.1555/.1560 x .23 DP (2)	Ø.1555/.1560 x .23 DP (2)	Ø.1555/.1560 x .23 DP (2)
mm	Ø3.948/3.961 x 5.8 DP (2)	Ø3.948/3.961 x 5.8 DP (2)	Ø3.948/3.961 x 5.8 DP (2)
H	Ø.22 THRU (4)	Ø.22 THRU (4)	Ø.22 THRU (4)
mm	Ø5.7 THRU (4)	Ø5.7 THRU (4)	Ø5.7 THRU (4)
I	2.38	2.38	2.38
mm	60.5	60.5	60.5
J	2.49	1.93	2.37
mm	63.2	49.0	60.2
K	1.34	1.34	1.34
mm	34.0	34.0	34.0
L	2.80	2.60	3.42
mm	71.1	66.0	86.9
M	2.80	2.60	3.25
mm	71.1	66.0	82.6
N	#10-24 x 0.75 DP (4)	M5X0.8 x .40 DP (4)	M5X0.8 x .40 DP (4)
mm	#10-24 x 19.1 DP (4)	M5X0.8 x 10.2 DP (4)	M5X0.8 x 10.2 DP (4)
O	Ø2.625 BC	Ø2.625 BC	Ø3.875 BC
mm	Ø66.68 BC	Ø66.68 BC	Ø98.43 BC
P	Ø1.504	Ø1.504	Ø2.877
mm	Ø38.20	Ø38.20	Ø73.08



# S-SOLID BEARING AND P-PROFILED RAIL IN-LINE MOTOR MOUNTING

MXE40

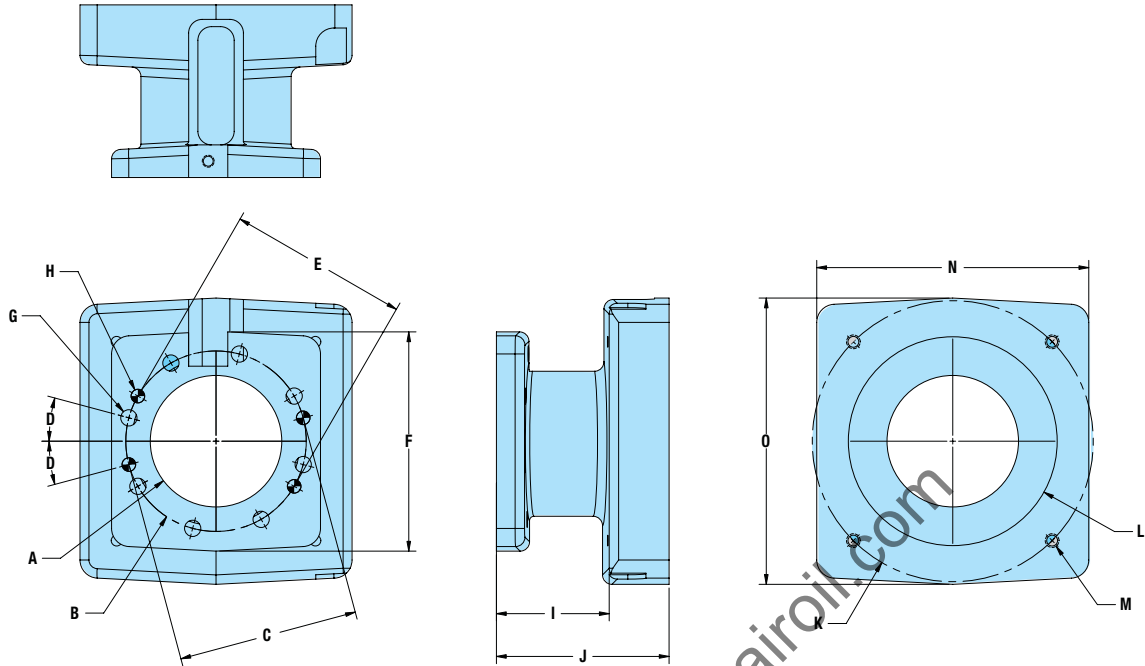

	MRV2x	MRV3x	MRS2x	MRS3x
A	Ø1.81	Ø1.81	Ø1.81	Ø1.81
mm	Ø46.0	Ø46.0	Ø46.0	Ø46.0
B	Ø2.488 BC	Ø2.488 BC	Ø2.488 BC	Ø2.488 BC
mm	Ø63.20 BC	Ø63.20 BC	Ø63.20 BC	Ø63.20 BC
C	2.488	2.488	2.488	2.488
mm	63.20	63.20	63.20	63.20
D	15°	15°	15°	15°
mm	15°	15°	15°	15°
E	2.488	2.488	-	-
mm	63.20	63.20	-	-
F	3.02	3.02	3.02	3.02
mm	76.7	76.7	76.7	76.7
G	Ø.22 THRU (8)	Ø.22 THRU (8)	Ø.22 THRU (4)	Ø.22 THRU (4)
mm	Ø.57 THRU (8)	Ø.57 THRU (8)	Ø.57 THRU (4)	Ø.57 THRU (4)
H	Ø.1865/.1875 x .23 DP (4)	Ø.1865/.1875 x .23 DP (4)	Ø.1865/.1875 x .23 DP (2)	Ø.1865/.1875 x .23 DP (2)
mm	Ø4.737/4.763 x 5.8 DP (4)	Ø4.737/4.763 x 5.8 DP (4)	Ø4.737/4.763 x 5.8 DP (2)	Ø4.737/4.763 x 5.8 DP (2)
I	1.53	1.56	1.52	1.56
mm	38.9	39.6	38.6	39.6
J	2.63	2.38	2.07	2.95
mm	66.8	60.5	52.6	74.9
K	Ø2.625	Ø3.875	Ø2.625	Ø3.875
mm	Ø66.68	Ø98.43	Ø66.68	Ø98.43
L	Ø1.504	Ø2.879	Ø1.504	Ø2.879
mm	Ø38.2	Ø73.13	Ø38.2	Ø73.13
M	#10-24 x .75 DP (4)	#10-24 x .75 DP (4)	M5x0.8 x .41 (4)	M5x0.8 x .41 (4)
mm	#10-24 x 19.1 DP (4)	#10-24 x 19.1 DP (4)	M5x0.8 x 10.4 (4)	M5x0.8 x 10.4 (4)
N	2.63	3.75	2.35	3.75
mm	66.8	95.3	59.7	95.3
O	2.63	3.95	2.35	3.95
mm	66.8	100.3	59.7	100.3

# S-SOLID BEARING REVERSE PARALLEL MOTOR MOUNTING DIMENSIONS

MXE25S

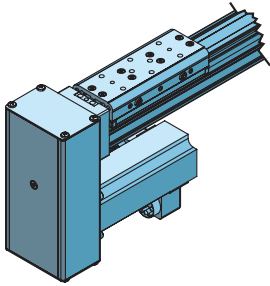

**REVERSE-PARALLEL BOTTOM (RPB)**  
mounting surface shown UP

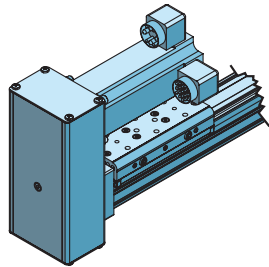

**REVERSE-PARALLEL TOP (RPT)**  
mounting surface shown UP

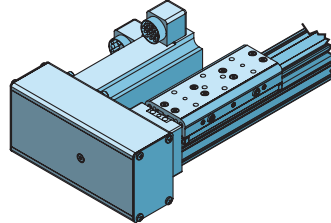

**REVERSE-PARALLEL LEFT (RPL)**  
mounting surface shown UP

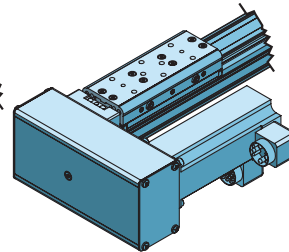

**REVERSE-PARALLEL RIGHT (RPR)**  
mounting surface shown UP

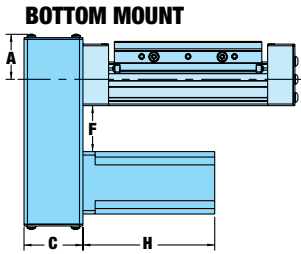

**BOTTOM MOUNT**

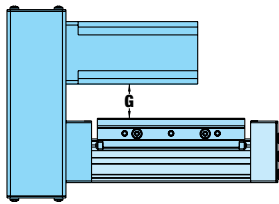

**TOP MOUNT**

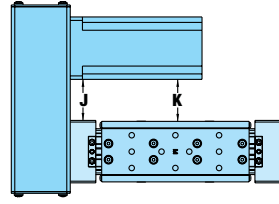

**SIDE MOUNT (Left Shown)**

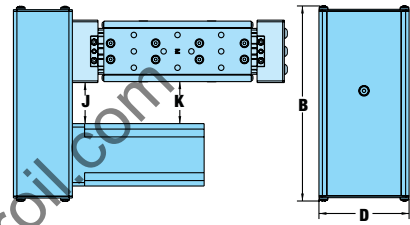

**SIDE MOUNT (Right Shown)**

MOTOR	WEIGHT OF REDUCTION DRIVE				REDUCTION INERTIA AT MOTOR SHAFT			
	1:1		2:1		1:1		2:1	
	lbs	kg	lbs	kg	lb-in <sup>2</sup>	kg-cm <sup>2</sup>	lb-in <sup>2</sup>	kg-cm <sup>2</sup>
<b>MRV BRUSHLESS ALL FRAME SIZES</b>	2.06	0.93	2.06	0.93	0.087	0.2559	0.112	0.3291
<b>STEPPER 23-FRAME</b>	1.92	0.87	1.92	0.87	0.022	0.064	0.046	0.135
<b>STEPPER 34-FRAME</b>	2.34	1.06	2.34	1.06	0.025	0.073	0.050	0.146

REDUCTION EFFICIENCY: 0.95

	A		B		C		D		F		G		H		J		K		
	in.	mm	in.	mm	in.	mm	in.	mm	in.	mm	in.	mm	in.	mm	in.	mm	in.	mm	
<b>BRUSHLESS</b>	<b>MRV21</b>	1.44	36.6	6.96	176.8	2.13	54.1	3.25	82.6	1.60	40.6	1.27	32.3	4.75	120.7	1.45	36.8	1.48	37.6
	<b>MRV22</b>	1.44	36.6	6.96	176.8	2.13	54.1	3.25	82.6	1.60	40.6	1.27	32.3	5.75	146.1	1.45	36.8	1.48	37.6
	<b>MRV23</b>	1.44	36.6	6.96	176.8	2.13	54.1	3.25	82.6	1.60	40.6	1.27	32.3	6.75	171.5	1.45	36.8	1.48	37.6
	<b>MRV24</b>	1.44	36.6	6.96	176.8	2.13	54.1	3.25	82.6	1.60	40.6	1.27	32.3	7.75	196.9	1.45	36.8	1.48	37.6
<b>STEPPER</b>	<b>MRS21</b>	1.44	36.6	6.96	176.8	2.13	54.1	3.25	82.6	1.60	40.6	1.27	32.3	1.71	43.4	1.45	36.8	1.48	37.6
	<b>MRS22</b>	1.44	36.6	6.96	176.8	2.13	54.1	3.25	82.6	1.60	40.6	1.27	32.3	2.19	55.6	1.45	36.8	1.48	37.6
	<b>MRS23</b>	1.44	36.6	6.96	176.8	2.13	54.1	3.25	82.6	1.60	40.6	1.27	32.3	3.05	77.5	1.45	36.8	1.48	37.6
	<b>MRS31</b>	1.96	49.8	7.47	189.7	2.38	60.5	4.00	101.6	1.02	25.9	0.69	17.5	3.11	79.0	0.87	22.1	0.9	22.9
	<b>MRS32</b>	1.96	49.8	7.47	189.7	2.38	60.5	4.00	101.6	1.02	25.9	0.69	17.5	4.63	117.6	0.87	22.1	0.9	22.9
	<b>MRS33</b>	1.96	49.8	7.47	189.7	2.38	60.5	4.00	101.6	1.02	25.9	0.69	17.5	6.14	156.0	0.87	22.1	0.9	22.9

# S-SOLID BEARING REVERSE PARALLEL MOTOR MOUNTING DIMENSIONS

MXE32S

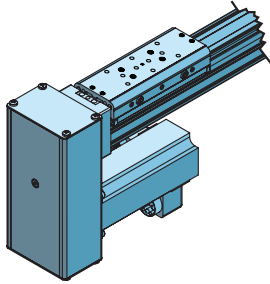

**REVERSE-PARALLEL BOTTOM (RPB)**  
mounting surface shown UP

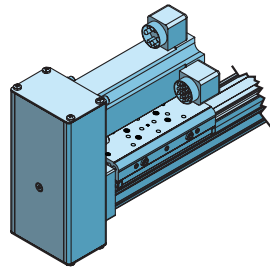

**REVERSE-PARALLEL TOP (RPT)**  
mounting surface shown UP

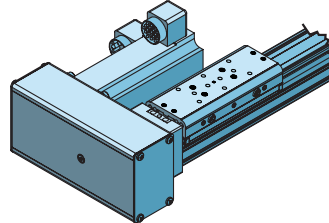

**REVERSE-PARALLEL LEFT (RPL)**  
mounting surface shown UP

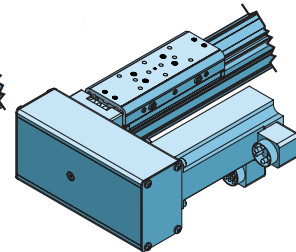

**REVERSE-PARALLEL RIGHT (RPR)**  
mounting surface shown UP

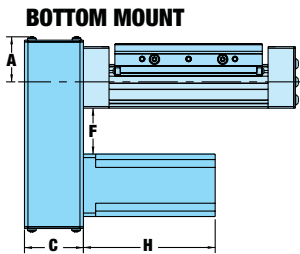

**BOTTOM MOUNT**

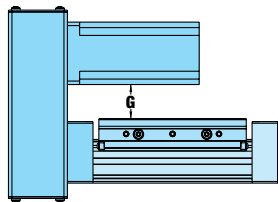

**TOP MOUNT**

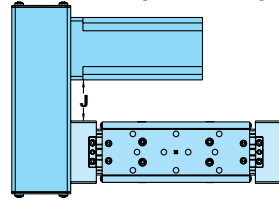

**SIDE MOUNT (Left Shown)**

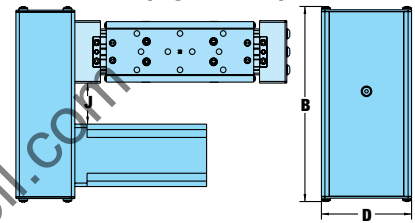

**SIDE MOUNT (Right Shown)**

MOTOR	WEIGHT OF REDUCTION DRIVE				REDUCTION INERTIA AT MOTOR SHAFT			
	1:1		2:1		1:1		2:1	
	lbs	kg	lbs	kg	lb-in <sup>2</sup>	kg-cm <sup>2</sup>	lb-in <sup>2</sup>	kg-cm <sup>2</sup>
<b>MRV BRUSHLESS ALL FRAME SIZES</b>	2.06	0.93	2.06	0.93	0.087	0.2559	0.112	0.3291
<b>STEPPER 23-FRAME</b>	1.92	0.87	1.92	0.87	0.022	0.064	0.046	0.135
<b>STEPPER 34-FRAME</b>	2.34	1.06	2.34	1.06	0.025	0.073	0.050	0.146

REDUCTION EFFICIENCY: 0.95

	MOTOR	A		B		D		F		G		H		J			
		in.	mm	in.	mm	in.	mm	in.	mm	in.	mm	in.	mm	in.	mm		
<b>BRUSHLESS</b>	<b>MRV21</b>	1.44	36.6	6.96	176.8	2.13	54.1	3.25	82.6	1.40	35.6	0.75	19.1	4.75	120.7	1.18	30.0
	<b>MRV22</b>	1.44	36.6	6.96	176.8	2.13	54.1	3.25	82.6	1.40	35.6	0.75	19.1	5.75	146.1	1.18	30.0
	<b>MRV23</b>	1.44	36.6	6.96	176.8	2.13	54.1	3.25	82.6	1.40	35.6	0.75	19.1	6.75	171.5	1.18	30.0
	<b>MRV24</b>	1.44	36.6	6.96	176.8	2.13	54.1	3.25	82.6	1.40	35.6	0.75	19.1	7.75	196.9	1.18	30.0
<b>STEPPER</b>	<b>MRS21</b>	1.44	36.6	6.96	176.8	2.13	54.1	3.25	82.6	1.40	35.6	0.75	19.1	1.71	43.4	1.18	30.0
	<b>MRS22</b>	1.44	36.6	6.96	176.8	2.13	54.1	3.25	82.6	1.40	35.6	0.75	19.1	2.19	55.6	1.18	30.0
	<b>MRS23</b>	1.44	36.6	6.96	176.8	2.13	54.1	3.25	82.6	1.40	35.6	0.75	19.1	3.05	77.5	1.18	30.0
	<b>MRS31</b>	1.96	49.8	7.47	189.7	2.38	60.5	4.00	101.6	0.82	20.8	0.17	4.3	3.11	79.0	0.6	15.2
	<b>MRS32</b>	1.96	49.8	7.47	189.7	2.38	60.5	4.00	101.6	0.82	20.8	0.17	4.3	4.63	117.6	0.6	15.2
	<b>MRS33</b>	1.96	49.8	7.47	189.7	2.38	60.5	4.00	101.6	0.82	20.8	0.17	4.3	6.14	156.0	0.6	15.2

# S-SOLID BEARING REVERSE PARALLEL MOTOR MOUNTING DIMENSIONS

**MXE40S**

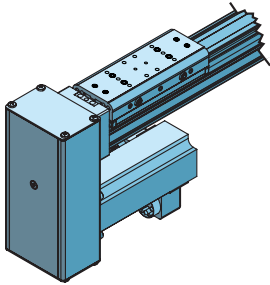

**REVERSE-PARALLEL BOTTOM (RPB)**

mounting surface shown UP

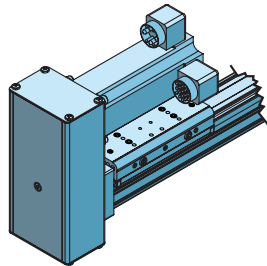

**REVERSE-PARALLEL TOP (RPT)**

mounting surface shown UP

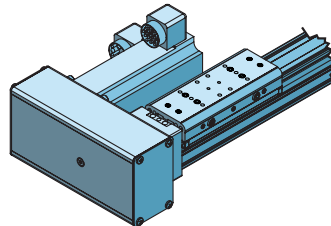

**REVERSE-PARALLEL LEFT (RPL)**

mounting surface shown UP

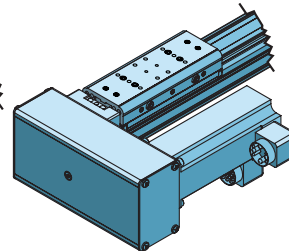

**REVERSE-PARALLEL RIGHT (RPR)**

mounting surface shown UP

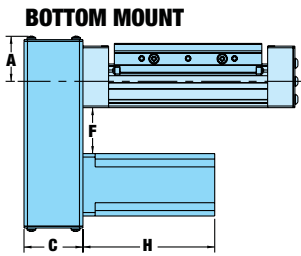

**BOTTOM MOUNT**

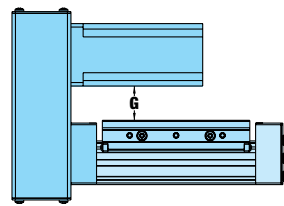

**TOP MOUNT**

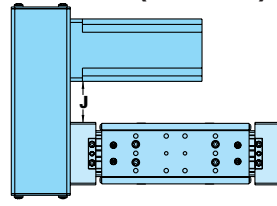

**SIDE MOUNT (Left Shown)**

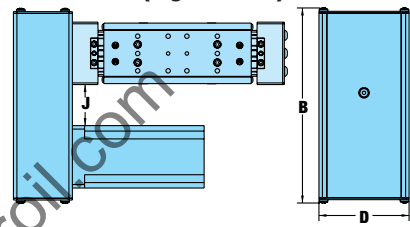

**SIDE MOUNT (Right Shown)**

MOTOR	WEIGHT OF REDUCTION DRIVE				REDUCTION INERTIA AT MOTOR SHAFT			
	1:1		2:1		1:1		2:1	
	lbs	kg	lbs	kg	lb-in <sup>2</sup>	kg-cm <sup>2</sup>	lb-in <sup>2</sup>	kg-cm <sup>2</sup>
<b>MRV BRUSHLESS ALL FRAME SIZES</b>	2.17	0.98	2.40	1.09	0.070	0.2043	0.095	0.2767
<b>STEPPER 23-FRAME</b>	2.03	0.92	2.26	1.03	0.022	0.064	0.054	0.159
<b>STEPPER 34-FRAME</b>	2.49	1.13	2.72	1.23	0.025	0.073	0.058	0.168

**REDUCTION EFFICIENCY: 0.95**

	MOTOR	A		B		C		D		F		G		H		J	
		in.	mm	in.	mm	in.	mm	in.	mm	in.	mm	in.	mm	in.	mm	in.	mm
<b>BRUSHLESS</b>	<b>MRV21</b>	1.44	36.6	7.46	189.5	2.13	54.1	3.25	82.6	1.57	39.9	1.13	28.7	4.75	120.7	1.37	34.8
	<b>MRV22</b>	1.44	36.6	7.46	189.5	2.13	54.1	3.25	82.6	1.57	39.9	1.13	28.7	5.75	146.1	1.37	34.8
	<b>MRV23</b>	1.44	36.6	7.46	189.5	2.13	54.1	3.25	82.6	1.57	39.9	1.13	28.7	6.75	171.5	1.37	34.8
	<b>MRV24</b>	1.44	36.6	7.46	189.5	2.13	54.1	3.25	82.6	1.57	39.9	1.13	28.7	7.75	196.9	1.37	34.8
	<b>MRV31</b>	2.12	53.8	8.14	206.8	2.38	60.5	4.00	101.6	0.92	23.4	0.48	12.2	6.11	155.2	0.72	18.3
	<b>MRV32</b>	2.12	53.8	8.14	206.8	2.38	60.5	4.00	101.6	0.92	23.4	0.48	12.2	7.36	186.9	0.72	18.3
<b>STEPPER</b>	<b>MRV33</b>	2.12	53.8	8.14	206.8	2.38	60.5	4.00	101.6	0.92	23.4	0.48	12.2	8.61	218.7	0.72	18.3
	<b>MRS21</b>	1.44	36.6	7.46	189.5	2.13	54.1	3.25	82.6	1.57	39.9	1.13	28.7	1.71	43.4	1.37	34.8
	<b>MRS22</b>	1.44	36.6	7.46	189.5	2.13	54.1	3.25	82.6	1.57	39.9	1.13	28.7	2.19	55.6	1.37	34.8
	<b>MRS23</b>	1.44	36.6	7.46	189.5	2.13	54.1	3.25	82.6	1.57	39.9	1.13	28.7	3.05	77.5	1.37	34.8
	<b>MRS31</b>	2.12	53.8	8.14	206.8	2.38	60.5	4.00	101.6	0.99	25.1	0.55	14.0	3.11	79.0	0.79	22.1
	<b>MRS32</b>	2.12	53.8	8.14	206.8	2.38	60.5	4.00	101.6	0.99	25.1	0.55	14.0	4.63	117.6	0.79	22.1
	<b>MRS33</b>	2.12	53.8	8.14	206.8	2.38	60.5	4.00	101.6	0.99	25.1	0.55	14.0	6.14	156.0	0.79	22.1

# P-PROFILED RAIL REVERSE PARALLEL MOTOR MOUNTING DIMENSIONS

MXE25P

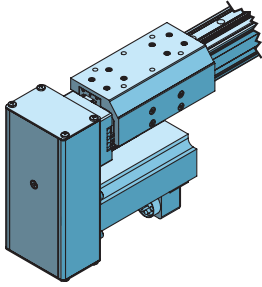

**REVERSE-PARALLEL BOTTOM (RPB)**  
mounting surface shown UP

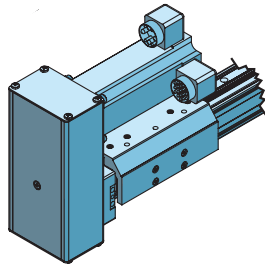

**REVERSE-PARALLEL TOP (RPT)**  
mounting surface shown UP

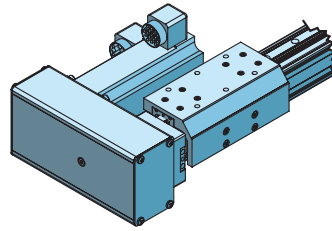

**REVERSE-PARALLEL LEFT (RPL)**  
mounting surface shown UP

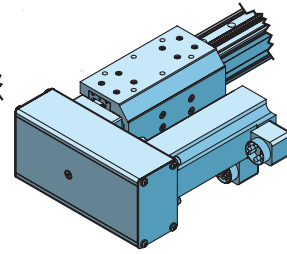

**REVERSE-PARALLEL RIGHT (RPR)**  
mounting surface shown UP

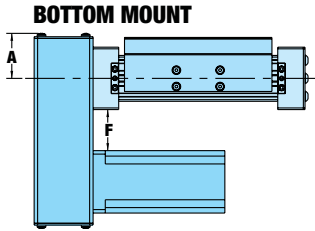

**BOTTOM MOUNT**

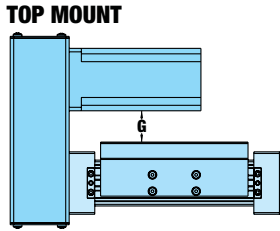

**TOP MOUNT**

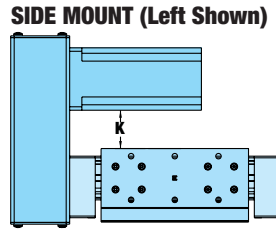

**SIDE MOUNT (Left Shown)**

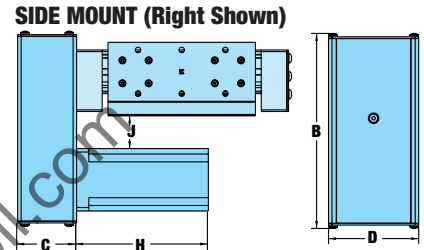

**SIDE MOUNT (Right Shown)**

MOTOR	WEIGHT OF REDUCTION DRIVE				REDUCTION INERTIA AT MOTOR SHAFT			
	1:1		2:1		1:1		2:1	
	lbs	kg	lbs	kg	lb-in <sup>2</sup>	kg-cm <sup>2</sup>	lb-in <sup>2</sup>	kg-cm <sup>2</sup>
<b>MRV BRUSHLESS ALL FRAME SIZES</b>	2.06	0.93	2.06	0.93	0.087	0.2559	0.112	0.3291
<b>STEPPER 23-FRAME</b>	1.92	0.87	1.92	0.87	0.022	0.064	0.046	0.135
<b>STEPPER 34-FRAME</b>	2.34	1.06	2.34	1.06	0.025	0.073	0.050	0.146

REDUCTION EFFICIENCY: 0.95

	MOTOR	A		B		C		D		F		G		H		J		K	
		in.	mm	in.	mm	in.	mm	in.	mm	in.	mm	in.	mm	in.	mm	in.	mm	in.	mm
BRUSHLESS	MRV21	1.44	36.6	6.96	176.8	2.13	54.1	3.25	82.6	1.48	37.6	1.13	28.7	4.75	120.7	1.18	30.0	1.38	35.1
	MRV22	1.44	36.6	6.96	176.8	2.13	54.1	3.25	82.6	1.48	37.6	1.13	28.7	5.75	146.1	1.18	30.0	1.38	35.1
	MRV23	1.44	36.6	6.96	176.8	2.13	54.1	3.25	82.6	1.48	37.6	1.13	28.7	6.75	171.5	1.18	30.0	1.38	35.1
	MRV24	1.44	36.6	6.96	176.8	2.13	54.1	3.25	82.6	1.48	37.6	1.13	28.7	7.75	196.9	1.18	30.0	1.38	35.1
STEPPER	MRS21	1.44	36.6	6.96	176.8	2.13	54.1	3.25	82.6	1.48	37.6	1.13	28.7	1.71	43.4	1.18	30.0	1.38	35.1
	MRS22	1.44	36.6	6.96	176.8	2.13	54.1	3.25	82.6	1.48	37.6	1.13	28.7	2.19	55.6	1.18	30.0	1.38	35.1
	MRS23	1.44	36.6	6.96	176.8	2.13	54.1	3.25	82.6	1.48	37.6	1.13	28.7	3.05	77.5	1.18	30.0	1.38	35.1
	MRS31	1.96	49.8	7.47	189.7	2.38	60.5	4.00	101.6	0.90	22.9	0.55	14.0	3.11	79.0	0.66	16.8	0.8	20.3
	MRS32	1.96	49.8	7.47	189.7	2.38	60.5	4.00	101.6	0.90	22.9	0.55	14.0	4.63	117.6	0.66	16.8	0.8	20.3
	MRS33	1.96	49.8	7.47	189.7	2.38	60.5	4.00	101.6	0.90	22.9	0.55	14.0	6.14	156.0	0.66	16.8	0.8	20.3

# P-PROFILED RAIL REVERSE PARALLEL MOTOR MOUNTING DIMENSIONS

MXE32P

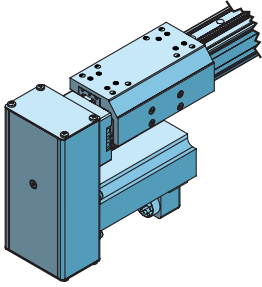

**REVERSE-PARALLEL BOTTOM (RPB)**  
mounting surface shown UP

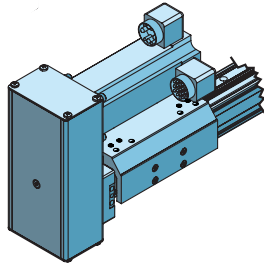

**REVERSE-PARALLEL TOP (RPT)**  
mounting surface shown UP

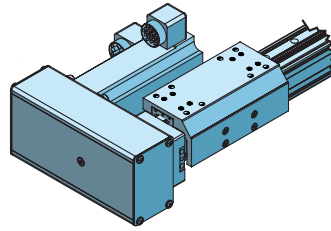

**REVERSE-PARALLEL LEFT (RPL)**  
mounting surface shown UP

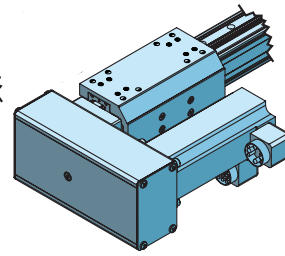

**REVERSE-PARALLEL RIGHT (RPR)**  
mounting surface shown UP

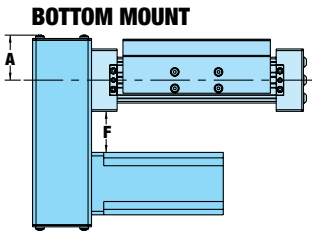

**BOTTOM MOUNT**

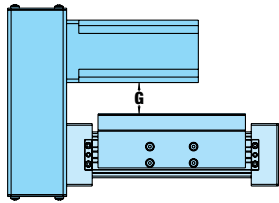

**TOP MOUNT**

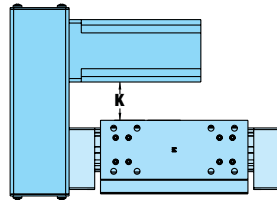

**SIDE MOUNT (Left Shown)**

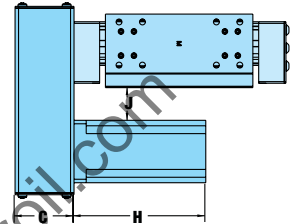

**SIDE MOUNT (Right Shown)**

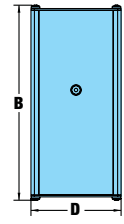

MOTOR	WEIGHT OF REDUCTION DRIVE				REDUCTION INERTIA AT MOTOR SHAFT			
	1:1		2:1		1:1		2:1	
	lbs	kg	lbs	kg	lb-in <sup>2</sup>	kg-cm <sup>2</sup>	lb-in <sup>2</sup>	kg-cm <sup>2</sup>
<b>MRV BRUSHLESS ALL FRAME SIZES</b>	2.06	0.93	2.06	0.93	0.087	0.2559	0.112	0.3291
<b>STEPPER 23-FRAME</b>	1.92	0.87	1.92	0.87	0.022	0.064	0.046	0.135
<b>STEPPER 34-FRAME</b>	2.34	1.06	2.34	1.06	0.025	0.073	0.050	0.146

REDUCTION EFFICIENCY: 0.95

	MOTOR	A		B		C		D		F		G		H		J		K	
		in.	mm	in.	mm	in.	mm	in.	mm	in.	mm	in.	mm	in.	mm	in.	mm	in.	mm
BRUSHLESS	MRV21	1.44	36.6	6.96	176.8	2.13	54.1	3.25	82.6	1.52	38.6	0.65	16.5	4.75	120.7	0.76	19.3	1.20	30.5
	MRV22	1.44	36.6	6.96	176.8	2.13	54.1	3.25	82.6	1.52	38.6	0.65	16.5	5.75	146.1	0.76	19.3	1.20	30.5
	MRV23	1.44	36.6	6.96	176.8	2.13	54.1	3.25	82.6	1.52	38.6	0.65	16.5	6.75	171.5	0.76	19.3	1.20	30.5
	MRV24	1.44	36.6	6.96	176.8	2.13	54.1	3.25	82.6	1.52	38.6	0.65	16.5	7.75	196.9	0.76	19.3	1.20	30.5
STEPPER	MRS21	1.44	36.6	6.96	176.8	2.13	54.1	3.25	82.6	1.52	38.6	0.65	16.5	1.71	43.4	0.76	19.3	1.20	30.5
	MRS22	1.44	36.6	6.96	176.8	2.13	54.1	3.25	82.6	1.52	38.6	0.65	16.5	2.19	55.6	0.76	19.3	1.20	30.5
	MRS23	1.44	36.6	6.96	176.8	2.13	54.1	3.25	82.6	1.52	38.6	0.65	16.5	3.05	77.5	0.76	19.3	1.20	30.5
	MRS31	1.96	49.8	7.47	189.7	2.38	60.5	4.00	101.6	0.94	23.9	0.07	1.8	3.11	79.0	0.18	4.6	0.62	15.7
	MRS32	1.96	49.8	7.47	189.7	2.38	60.5	4.00	101.6	0.94	23.9	0.07	1.8	4.63	117.6	0.18	4.6	0.62	15.7
	MRS33	1.96	49.8	7.47	189.7	2.38	60.5	4.00	101.6	0.94	23.9	0.07	1.8	6.14	156.0	0.18	4.6	0.60	15.7

# P-PROFILED RAIL REVERSE PARALLEL MOTOR MOUNTING DIMENSIONS

**MXE40P**

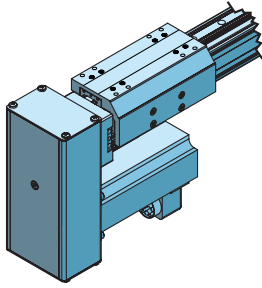

**REVERSE-PARALLEL BOTTOM (RPB)**  
mounting surface shown UP

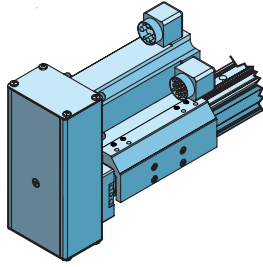

**REVERSE-PARALLEL TOP (RPT)**  
mounting surface shown UP

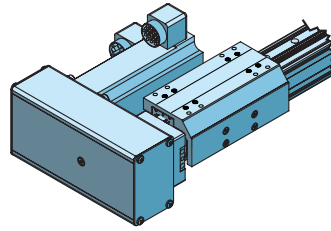

**REVERSE-PARALLEL LEFT (RPL)**  
mounting surface shown UP

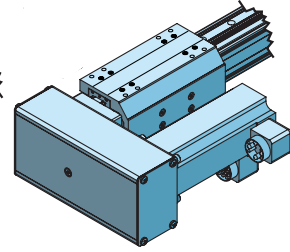

**REVERSE-PARALLEL RIGHT (RPR)**  
mounting surface shown UP

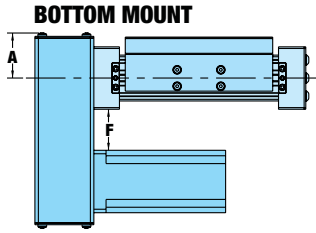

**BOTTOM MOUNT**

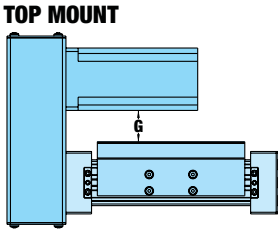

**TOP MOUNT**

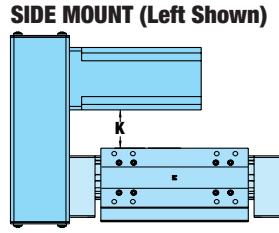

**SIDE MOUNT (Left Shown)**

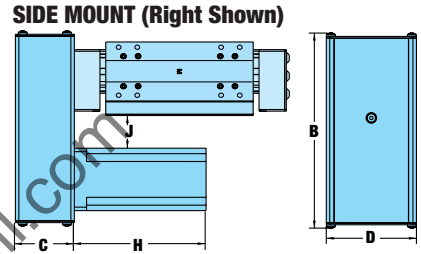

**SIDE MOUNT (Right Shown)**

MOTOR	WEIGHT OF REDUCTION DRIVE				REDUCTION INERTIA AT MOTOR SHAFT			
	1:1		2:1		1:1		2:1	
	lbs	kg	lbs	kg	lb-in <sup>2</sup>	kg-cm <sup>2</sup>	lb-in <sup>2</sup>	kg-cm <sup>2</sup>
MRV BRUSHLESS ALL FRAME SIZES	2.17	0.98	2.40	1.09	0.070	0.2043	0.095	0.2767
STEPPER 23-FRAME	2.03	0.92	2.26	1.03	0.022	0.064	0.054	0.159
STEPPER 34-FRAME	2.49	1.13	2.72	1.23	0.025	0.073	0.058	0.168

REDUCTION EFFICIENCY: 0.95

	MOTOR	A		B		C		D		F		G		H		J		K	
		in.	mm	in.	mm	in.	mm	in.	mm	in.	mm	in.	mm	in.	mm	in.	mm	in.	mm
BRUSHLESS	MRV21	1.44	36.6	7.46	189.5	2.13	54.1	3.25	82.6	1.61	40.9	0.83	21.1	4.75	120.7	1.18	30.0	1.18	30.0
	MRV22	1.44	36.6	7.46	189.5	2.13	54.1	3.25	82.6	1.61	40.9	0.83	21.1	5.75	146.1	1.18	30.0	1.18	30.0
	MRV23	1.44	36.6	7.46	189.5	2.13	54.1	3.25	82.6	1.61	40.9	0.83	21.1	6.75	171.5	1.18	30.0	1.18	30.0
	MRV24	1.44	36.6	7.46	189.5	2.13	54.1	3.25	82.6	1.61	40.9	0.83	21.1	7.75	196.9	1.18	30.0	1.18	30.0
	MRV31	2.12	53.8	8.14	206.8	2.38	60.5	4.00	101.6	0.96	24.4	0.18	4.6	6.11	155.2	0.53	13.5	0.53	13.5
	MRV32	2.12	53.8	8.14	206.8	2.38	60.5	4.00	101.6	0.96	24.4	0.18	4.6	7.36	186.9	0.53	13.5	0.53	13.5
	MRV33	2.12	53.8	8.14	206.8	2.38	60.5	4.00	101.6	0.96	24.4	0.18	4.6	8.61	218.7	0.53	13.5	0.53	13.5
STEPPER	MRS21	1.44	36.6	7.46	189.5	2.13	54.1	3.25	82.6	1.61	40.9	0.83	21.1	1.71	43.4	1.18	30.0	1.18	30.0
	MRS22	1.44	36.6	7.46	189.5	2.13	54.1	3.25	82.6	1.61	40.9	0.83	21.1	2.19	55.6	1.18	30.0	1.18	30.0
	MRS23	1.44	36.6	7.46	189.5	2.13	54.1	3.25	82.6	1.61	40.9	0.83	21.1	3.05	77.5	1.18	30.0	1.18	30.0
	MRS31	1.96	49.8	8.14	206.8	2.38	60.5	4.00	101.6	1.03	26.2	0.25	6.4	3.11	79.0	0.6	15.2	0.6	15.2
	MRS32	1.96	49.8	8.14	206.8	2.38	60.5	4.00	101.6	1.03	26.2	0.25	6.4	4.63	117.6	0.6	15.2	0.6	15.2
	MRS33	1.96	49.8	8.14	206.8	2.38	60.5	4.00	101.6	1.03	26.2	0.25	6.4	6.14	156.0	0.6	15.2	0.6	15.2

# SWITCHES

## SPECIFICATIONS



MX products offer a wide range of sensing choices. There are 12 switch choices: reed, solid state PNP (sourcing) or solid state NPN (sinking); in normally open or normally closed; with flying leads or quick disconnect.

Commonly used for end-of-stroke positioning, these switches allow drop-in installation anywhere along the entire actuator length. The one piece design includes the retained fastening hardware and is designed for any open side or bottom slot on the MX. The internal piston magnet is a standard feature, therefore these switches can be installed in the field at any time.

Switches are used to send analog signals to PLC (programmable logic controller), TLL, CMOS circuit or other controller device. Switches contain reverse polarity protection. Solid state QD cables are shielded; shield should be terminated at flying lead end.

All switches are CE rated and are RoHS compliant. Switches feature bright red or yellow LED signal indicators; solid state switches also have green LED power indicators.

	Order Code	Part Number	Lead	Switching Logic	Power LED	Signal LED	Operating Voltage	**Power Rating (Watts)	Switching Current (mA max.)	Current Consumption	Voltage Drop	Leakage Current	Temp. Range	Shock / Vibration
REED	<b>R Y</b>	8100-9082	5m	SPST Normally Open	—	Red	5 - 240 AC/DC	**10.0	100mA	—	3.0 V max.	—	14 to 158°F	50 G / 9 G
	<b>R K</b>	8100-9083	QD*											
	<b>N Y</b>	8100-9084	5m	SPST Normally Closed	—	Yellow	5 - 170 AC/DC							
	<b>N K</b>	8100-9085	QD*											
SOLID STATE	<b>T Y</b>	8100-9088	5m	PNP (Sourcing) Normally Open	Green	Yellow	10 - 30 VDC	**3.0	100mA	20 mA @ 24V	2.0 V max.	0.05 mA max.		
	<b>T K</b>	8100-9089	QD*											
	<b>K Y</b>	8100-9090	5m	NPN (Sinking) Normally Open	Green	Red								
	<b>K K</b>	8100-9091	QD*											
	<b>P Y</b>	8100-9092	5m	PNP (Sourcing) Normally Closed	Green	Yellow								
	<b>P K</b>	8100-9093	QD*											
	<b>H Y</b>	8100-9094	5m	NPN (Sinking) Normally Closed	Green	Red								
	<b>H K</b>	8100-9095	QD*											

\*QD = Quick disconnect Enclosure classification IEC 529 IP67 (NEMA 6)

CABLES: Robotic grade, oil resistant polyurethane jacket, PVC insulation

⚠️\*\*WARNING: Do not exceed power rating (Watt = Voltage x Amperage). Permanent damage to sensor will occur.



# SWITCHES

## WIRING DIAGRAMS

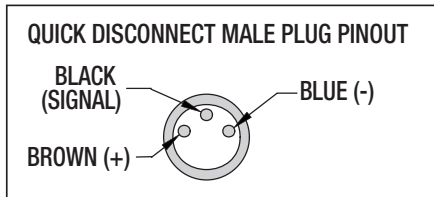
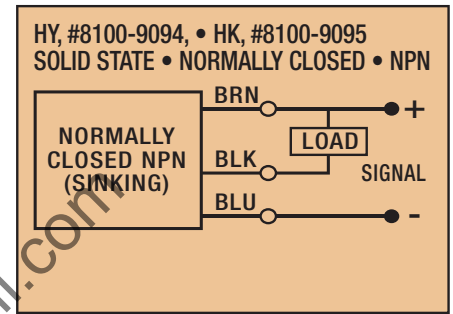
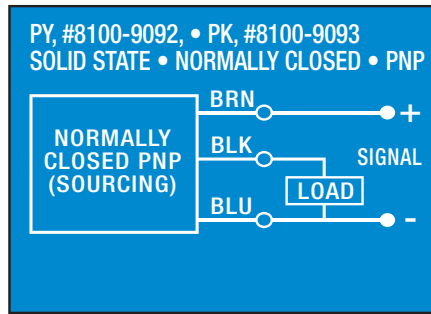
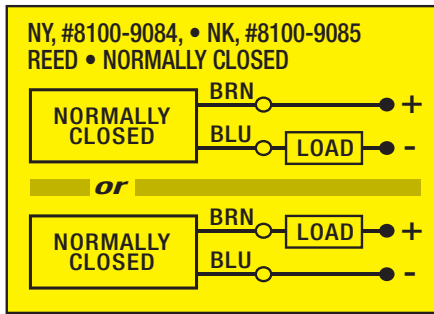
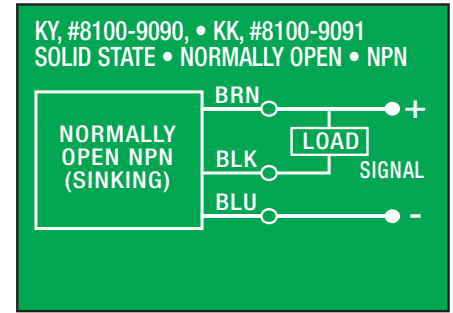
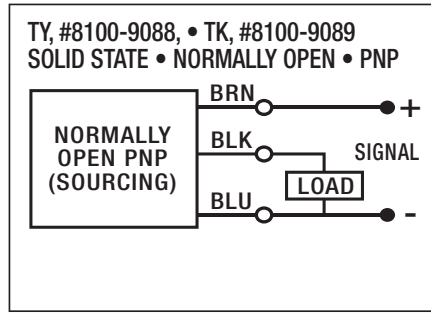
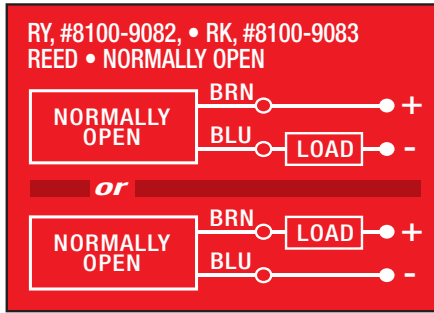

## SWITCH INSTALLATION AND REPLACEMENT

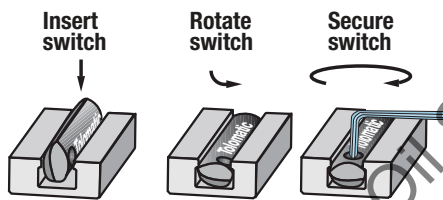

Place switch in side groove on tube at desired location with "Tolomatic" facing outward. While applying light pressure to the switch, rotate it such that the switch is halfway in the groove. Maintaining light pressure, rotate the switch in the opposite direction until the switch is fully inside the groove with "Tolomatic" visible. Re-position the switch to the exact location and lock the switch securely into place by tightening the screw on the switch.

# SWITCHES

## SWITCH DIMENSIONS

**Y** - direct connect

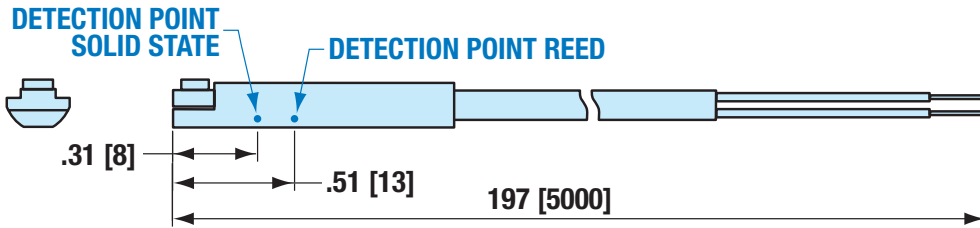

**K** - QD (Quick disconnect) switch

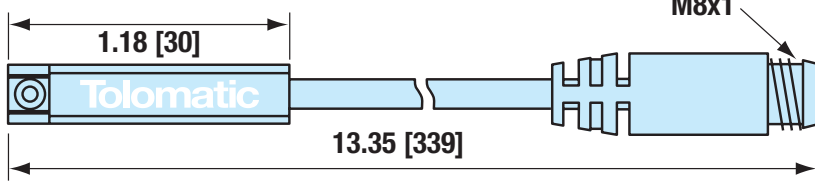

**8100-9180 - QD Cable**

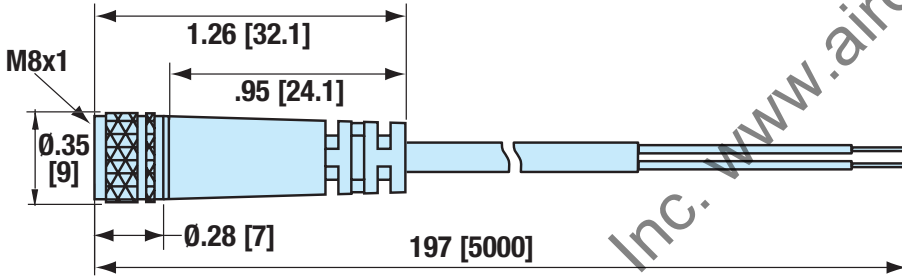

## MOUNTING DIMENSIONS

**MX\_25 MX\_32**  
SWITCHES SIT BELOW  
TUBE EXTRUSION PROFILE

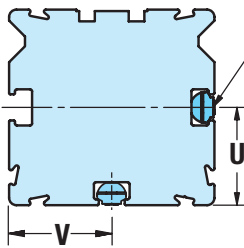

**MX\_40**  
SWITCHES SIT BELOW  
TUBE EXTRUSION PROFILE

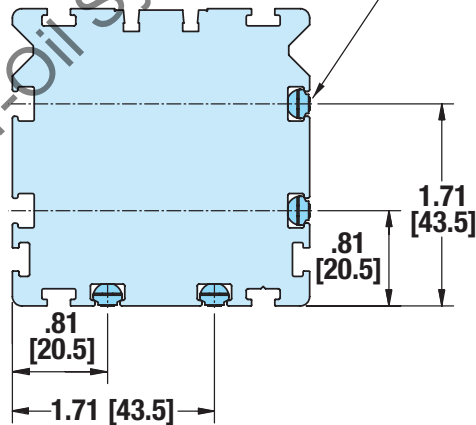

	MX_25	MX_32
<b>U</b>	.79	1.06
mm	20.0	27.0
<b>V</b>	.83	1.09
mm	21.0	27.7

Dimensions in inches [brackets indicate dimensions in millimeters]

## ADJUSTMENT PROCEDURES

### **S** SOLID BEARING CARRIER BRACKET ADJUSTMENT

The **S** solid bearing carrier will provide maximum life when properly adjusted. The carrier design contains both tension and lock screws. The tension screws control the amount of pressure placed on the carrier bearings. The lock screws lock the tension screws in place and provide fine adjustment of the carrier bearings. The number of tension and lock screws will vary depending on the size of the actuator.

1. Fully loosen all tension and lock screws so that they are not engaged with the bearing. They do not need to be removed from the screw hole, just fully loosened.
2. Tighten tension screws on both sides of carrier roughly 1/8 to 1/4 turn clockwise past where the screw starts to feel snug. The carrier should be very difficult or impossible to move by hand.
3. Next, adjust the lock screws on both sides of the carrier roughly 1/8 to 1/4 turn clockwise past where the screw starts to engage.
4. Ideal carrier tension is achieved when the carrier feels snug in relation to the tube, yet moves with minimal force. No rocking motion should be present. The carrier should be loose enough to be moved by hand over the entire length of the actuator. If after this process the carrier has become too loose, equally adjust all of the lock screws with a slight 1/32 turn counter-clockwise. A carrier that is adjusted too tight will increase the friction force; in extreme cases no motion will occur.

Depending on the duty cycle of the application, this process may need to be repeated. Keeping the carrier in a properly adjusted tension will prolong the life of the **S** solid bearing system.

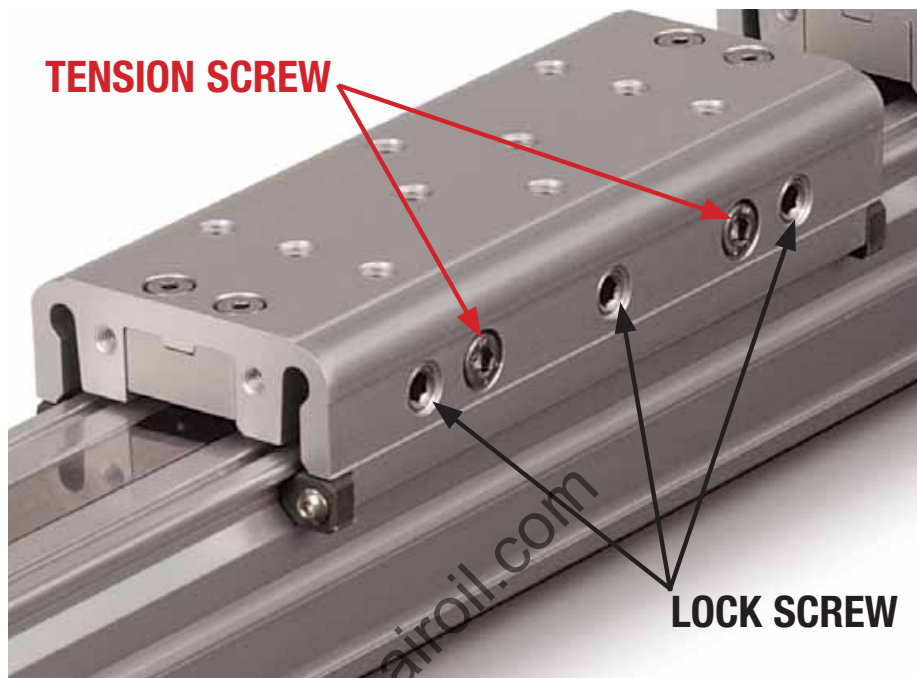

# COMPILE APPLICATION REQUIREMENTS

## APPLICATION DATA WORKSHEET

Fill in known data. Not all information is required for all applications

### ORIENTATION

Horizontal  Side  Horizontal Down  Vertical  Angled °

Load attached to carrier OR  Load supported by other mechanism

### DISTANCE FROM CENTER OF CARRIER TO LOAD CENTER OF GRAVITY

$d_x$  \_\_\_\_\_  
 $d_y$  \_\_\_\_\_  
 $d_z$  \_\_\_\_\_

inch (U.S. Standard)  mm (Metric)

### STROKE LENGTH

inch (S I) (U.S. Standard)  millimeters (S M) (Metric)

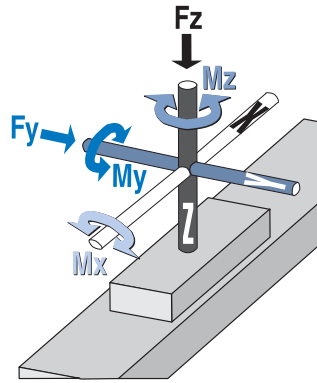

### BENDING MOMENTS APPLIED TO CARRIER

in.-lbs. (U.S. Standard)  N-m (Metric)

$M_x$  \_\_\_\_\_  
 $M_y$  \_\_\_\_\_  
 $M_z$  \_\_\_\_\_

### PRECISION

Repeatability \_\_\_\_\_  
 inch.  millimeters

**NOTE:** If load or force on carrier changes during cycle use the highest numbers for calculations

### LOAD

lb. (U.S. Standard)  kg. (Metric)

### FORCES APPLIED TO CARRIER

lbf. (U.S. Standard)  N (Metric)

$F_z$  \_\_\_\_\_  
 $F_y$  \_\_\_\_\_

**OPERATING ENVIRONMENT**  
 Temperature, Contamination, etc.

\_\_\_\_\_  
 \_\_\_\_\_  
 \_\_\_\_\_

### MOVE PROFILE

Move Distance \_\_\_\_\_  
 inch  millimeters

Dwell Time After Move \_\_\_\_\_  
 Max. Speed \_\_\_\_\_  
 in/sec  mm/sec

### MOVE TIME

sec

### NO. OF CYCLES

per minute  per hour

### MOTION PROFILE

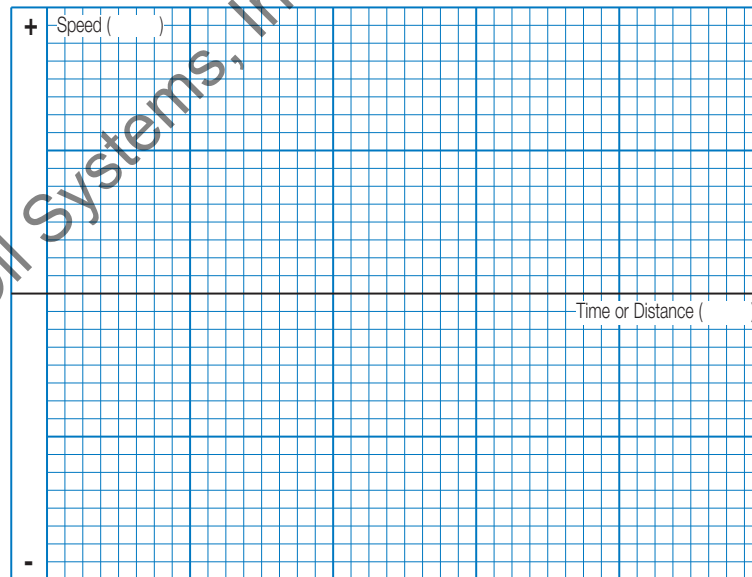

Graph your most demanding cycle, including accel/decel, velocity and dwell times. You may also want to indicate load variations and I/O changes during the cycle. Label axes with proper scale and units.

### CONTACT INFORMATION

Name, Phone, Email \_\_\_\_\_  
 Co. Name, Etc. \_\_\_\_\_



**USE THE TOLOMATIC SIZING AND SELECTION SOFTWARE AVAILABLE ON-LINE AT [www.tolomatic.com](http://www.tolomatic.com) OR... CALL TOLOMATIC 1-800-328-2174** with the above information. We will provide any assistance needed to determine the proper MX actuator for the job.

**FAX 1-763-478-8080**

## SELECTION GUIDELINES

The process of selecting a load bearing actuator for a given application can be complex. It is highly recommended that you contact Tolomatic or a Tolomatic Distributor for assistance in selecting the best actuator for your application. The following overview of the selection guidelines are for educational purposes only.

### 1 CHOOSE ACTUATOR BEARING STYLE & SIZE

Choose an actuator that has the thrust, speed and moment load capacity to move the load. Use the Speed/Stroke graph (page 15) for the screw and the Moment and Load Capacity tables (page 10) for the actuator.

### 2 COMPARE LOAD TO MAXIMUM LOAD CAPACITIES

Calculate the application load (combination of load mass and forces applied to the carrier) and application bending moments (sum of all moments  $M_x$ ,  $M_y$ , and  $M_z$  applied to the carrier). Be sure to evaluate the magnitude of dynamic inertia moments. When a rigidly attached load mass is accelerated or decelerated, its inertia induces bending moments on the carrier. Careful attention to how the load is decelerated at the end of the stroke is required for extended actuator performance and application safety. If either load or any of your moments ex-

ceed figures indicated in the Moment and Load Capacity tables (page 10) for the actuator consider:

- 1) Higher capacity bearing style i.e. **S** Solid to **P** Profiled Rail
- 2) A larger actuator size
- 3) Auxiliary carrier
- 4) External guide system

### 3 CALCULATE LOAD FACTOR LF

For loads with a center of gravity offset from the carrier account for both applied (static) and dynamic loads. The load factor ( $L_f$ ) must not exceed the value of 1.

$$L_f = \frac{M_x}{M_{x_{max}}} + \frac{M_y}{M_{y_{max}}} + \frac{M_z}{M_{z_{max}}} + \frac{F_y}{F_{y_{max}}} + \frac{F_z}{F_{z_{max}}} \leq 1$$

If  $L_f$  does exceed the value of 1, consider the four choices listed in step #2.

### 4 ESTABLISH YOUR MOTION PROFILE AND CALCULATE ACCELERATION RATE

Using the application stroke length and maximum carrier velocity (or time to complete the linear motion), establish the motion profile. Select either triangular (accel-decel) or trapezoidal (accel-constant speed-decel) profile. Now calculate the maximum acceleration and deceleration rates of the move. Acceleration/deceleration should not exceed critical speed (page 15) for the screw/nut combination chosen. Also, do not exceed safe rates of dynamic inertia moments determined in step #3.

### 5 SELECT THE LEAD SCREW

Based on the application requirements for accuracy, backlash, quiet operation, life, etc. Select the appropriate lead screw type (Acme screw with a solid nut or ball screw with a standard or anti-backlash nut) and the pitch (lead). For additional information on screw selection, consult "Which Screw? Picking the Right Technology" (#9900-4644) available at [www.tolomatic.com](http://www.tolomatic.com).

### 6 SELECT MOTOR (GEARHEAD IF NECESSARY) AND DRIVE

To help select a motor and drive, use the sizing equations located in the Engineering Resources section of the Tolomatic Electric Products Catalog (#3600-4609) to calculate the application thrust and torque requirements. Refer to Motor sections to determine the motor and drive.

### 7 DETERMINE TUBE CLAMP/MOUNTING PLATE REQUIREMENTS

- Consult the Tube Clamp Requirements graph for the model selected (page 14)
- Cross reference the application load and maximum distance between supports
- Select the appropriate number of tube clamps, and mounting plates if required for motor and adapter clearance.

### 8 CONSIDER OPTIONS

- Choose metric or inch (US standard) load mounting. (When ordering use **SX** for inch and **SM** for metric)
- Switches - Reed, Solid State PNP or NPN, all available normally open or normally closed
- **FL** Floating mount bracket - used when lack of parallelism occurs between the actuator and an externally guided and supported load (available for **S** Solid bearing style MXE actuators)

#### **S** SOLID BEARING 2:1 RULE

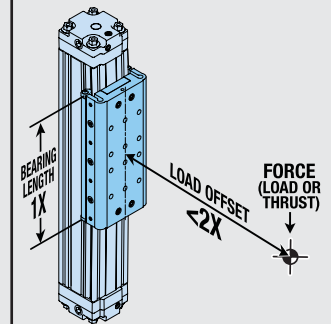

For applications using **S** solid bearings, binding or interrupted motion may occur if the load offset is equal to or greater than twice the bearing length (1X). *LOAD OFFSET* is defined as: the distance from the applied force (or the load center of gravity) to the centerline of the carrier.

If the load offset cannot be changed consider:

- 1.) Higher capacity bearing style, i.e. **S** to **P**
- 2.) Larger Bore Cylinder
- 3.) Auxiliary Carrier
- 4.) Add External Guides

# FIELD RETROFIT ORDERING

## REPAIR KITS

Repair kit includes: dust band, end caps, [Also for **S** style: bearings and bearing caps]

The part number for a repair kit begins with RK followed by model, actuator size, bearing type, and stroke length (**S****K** = inch/US Standard, **S****M** = metric) (NOTE: If unit has an auxiliary carrier also include DC and distance between carrier centers)

REPAIR KIT	MODEL	ACTUATOR SIZE	BEARING TYPE	STROKE METRIC	STROKE LENGTH	AUXILIARY CARRIER	DISTANCE BETWEEN CARRIERS
<b>RK</b>	<b>MXE</b>	<b>40</b>	<b>S</b>	<b>SM</b>	<b>2007.02</b>	<b>DC</b>	<b>215.9</b>

## SWITCHES

### TO ORDER FIELD RETROFIT SWITCHES:

Switches for MXE include retained mounting hardware and are the same for all actuator sizes and bearing styles

Code	Part Number	Lead	Normally	Sensor Type
<b>R</b> <b>Y</b>	8100-9082	5m (197 in)	Open	Reed
<b>R</b> <b>K</b>	8100-9083*	Quick disconnect		
<b>N</b> <b>Y</b>	8100-9084	5m (197 in)	Closed	Reed
<b>N</b> <b>K</b>	8100-9085*	Quick disconnect		
<b>T</b> <b>Y</b>	8100-9088	5m (197 in)	Open	Solid State PNP
<b>T</b> <b>K</b>	8100-9089*	Quick disconnect		
<b>K</b> <b>Y</b>	8100-9090	5m (197 in)	Open	Solid State NPN
<b>K</b> <b>K</b>	8100-9091*	Quick disconnect		
<b>P</b> <b>Y</b>	8100-9092	5m (197 in)	Closed	Solid State PNP
<b>P</b> <b>K</b>	8100-9093*	Quick disconnect		
<b>H</b> <b>Y</b>	8100-9094	5m (197 in)	Closed	Solid State NPN
<b>H</b> <b>K</b>	8100-9095*	Quick disconnect		

\*Also order mating QD cable #8100-9080

	8100-9080	Mating QD (Quick disconnect) cable 197 in. (5m)
--	-----------	---

## OPTIONS

MOUNTING OPTIONS		25		32		40	
		<b>S</b> Solid	<b>P</b> Profiled Rail	<b>S</b> Solid	<b>P</b> Profiled Rail	<b>S</b> Solid	<b>P</b> Profiled Rail
Floating Mount	U.S.	8125-9519	NA	8132-9519	NA	8140-9519	NA
	Metric	8125-9019	NA	8132-9019	NA	8140-9019	NA
Mounting Plates Kits	23-Frame	8325-9016	8325-9016	8332-9016	8332-9016	8340-9016	8340-9016
	34-Frame	8325-9017	8325-9017	8332-9017	8332-9017	8340-9017	8340-9017

# ORDERING

MODEL SELECTION (MUST BE IN THIS ORDER)

**MXE 40 P SN02 SM2007-02**

OPTIONS (IN ANY ORDER)

**LMI DC215-9 TC8 TK2**

**MODEL**  
MXE MX Rodless Electric Actuator

**SERIES**  
25 Series actuator  
32 Series actuator  
40 Series actuator

**BEARING**  
S Solid Bearing  
P Profiled Rail

**NUT/SCREW CONFIGURATION**

SOLID NUT / PITCH (turn/in)	SERIES
SN01	MXE25, 32, 40
SN02	MXE25, 32, 40
SN05	MXE25, 32

BALL NUT / PITCH (turn/in)	SERIES
BN02	MXE40
BNL02	MXE40
BN05	MXE40
BNL05	MXE40
BN08	MXE25, 32
BNL08	MXE25, 32

**STROKE LENGTH & MOUNTING TYPE**

SK \_\_\_\_\_ Stroke, enter desired stroke length in **inches**

SM \_\_\_\_\_ Stroke, enter desired stroke length in **millimeters**

**NOTE: Actuator mounting threads and mounting fasteners will be either inch or metric; depending on how stroke length is indicated**

**SK=inch mounting**  
**SM= metric mounting**

**MOTOR MOUNTING / REDUCTION**  
*(must choose one)*

**LMI** In-Line mounting  
**LME23** Ext. shaft for RP & 23 frame motor  
**LME34** Ext. shaft for RP & 23 frame motor

**▲ A motor size and code must be selected when specifying a reverse-parallel mounting configuration. Reference the motor ordering pages in Electric Products Catalog #3600-4609.**

**RPL1** 1:1 Reserve-Parallel mount left  
**RPRI** 1:1 Reserve-Parallel mount right  
**RPB1** 1:1 Reserve-Parallel mount bottom  
**RPT1** 1:1 Reserve-Parallel mount top  
**RPL2** 2:1 Reserve-Parallel mount left  
**RPR2** 2:1 Reserve-Parallel mount right  
**RPB2** 2:1 Reserve-Parallel mount bottom  
**RPT2** 2:1 Reserve-Parallel mount top

**MOTOR / DRIVE / CONTROLLER / PLANETARY GEARBOX**

**▲ Reference the ordering pages in Electric Products Catalog #3600-4609 Stepper Products Brochure #3600-4160 & Planetary Gearbox Doc. #3600-4161**

**Visit [www.tolomatic.com](http://www.tolomatic.com) for the most up-to-date information or call Tolomatic 1-800-328-2174**

**AUXILIARY CARRIER**

DC \_\_\_\_\_ Auxiliary Carrier, enter center-to-center spacing desired in **inches (SK)** or **millimeters (SM)**

*(Same unit of measure as stroke length is required)*

**▲ Center-to-center spacing between carriers adds to overall length of the actuator, this distance will not be subtracted from stroke length specified in the previous step**

**MOUNTING**

**TC** Tube Clamps, enter number of pairs  
**FL** Floating Mount  
**MP** Mounting Plates, & quantity

**▲ NOTE: Floating Mount is not available with "P" Profiled Rail**

**SWITCHES**

**RY** Reed Switch (Normally Open) with 5-meter lead, & enter quantity desired  
**RK** Reed Switch (Normally Open) with 5-meter lead/QD, & quantity  
**NY** Reed Switch (Normally Closed) with 5-meter lead, & quantity  
**NK** Reed Switch (Normally Closed) with 5-meter lead/QD, & quantity

**TY** Solid State Switch PNP (Normally Open) w/ 5-meter lead, & quantity  
**TK** Solid State Switch PNP (Normally Open) w/ 5-meter lead/QD, & quantity  
**KY** Solid State Switch NPN (Normally Open) w/ 5-meter lead, & quantity  
**KK** Solid State Switch NPN (Normally Open) w/ 5-meter lead/QD, & quantity

**PY** Solid State Switch PNP (Normally Closed) w/ 5-meter lead, & quantity  
**PK** Solid State Switch PNP (Normally Closed) w/ 5-meter lead/QD, & quantity  
**HY** Solid State Switch NPN (Normally Closed) w/ 5-meter lead, & quantity  
**HK** Solid State Switch NPN (Normally Closed) w/ 5-meter lead/QD, & quantity

**VISIT [www.tolomatic.com/mxe](http://www.tolomatic.com/mxe) FOR COMPLETE, UP-TO-DATE INFORMATION**

**▲ Not all codes listed are compatible with all options.**

**Call Tolomatic 1-800-328-2174 to determine available options and accessories based on your application requirements.**

# THE TOLOMATIC DIFFERENCE What you expect from the industry leader:



## EXCELLENT TECHNICAL SUPPORT

Our people make the difference! Expect prompt, courteous replies to all of your application and product questions.



## 2D DRAWINGS & 3D MODELS AVAILABLE ON THE WEB

Easy to access CAD files are available in many popular formats.



## SIZING & SELECTION SOFTWARE

Windows® compatible, downloadable from our website – FREE – the best tool of its kind on the market! Product selection has never been easier.



## INDUSTRY LEADING DELIVERIES

Standard catalog products are built to order and ready-to-ship in 5 days or less. Modified and custom products ship weeks ahead of the competition.



## CUSTOM PRODUCTS

From standard catalog products... to modified products... to completely unique custom products, Tolomatic designs and builds the best solutions for your challenging applications.

### ALSO CONSIDER THESE OTHER TOLOMATIC PRODUCTS:

#### ELECTRIC PRODUCTS



Rod & Guided Rod Style Actuators, Screw & Belt Drive Rodless Actuators, High Thrust Actuators, Motors, Axiom Drives/Controllers

BROCHURE #9900-9074    ENDURANCE TECHNOLOGY BROCHURE #9900-4016    CATALOG #3600-4609    [www.tolomatic.com/electric](http://www.tolomatic.com/electric)

#### PNEUMATIC PRODUCTS



RODLESS CYLINDERS: Band Cylinders, Cable Cylinders, Magnetically Coupled Cylinders/Slides; Guided Rod Cylinder Slides

BROCHURE #9900-9075    MXP BROCHURE #8100-4000    BAND CYLINDER BROCHURE #9900-4015    CATALOG #9900-4000    [www.tolomatic.com/pneumatic](http://www.tolomatic.com/pneumatic)

#### POWER TRANSMISSION PRODUCTS



GEARBOXES: Float-A-Shaft™, Slide-Rite™, Disc Cone Clutch; Caliper Disc Brake

BROCHURE #9900-9076    CATALOG #9900-4009    [www.tolomatic.com/pt](http://www.tolomatic.com/pt)



3800 County Road 116 • Hamel, MN 55340 U.S.A.  
Phone: (763) 478-8000 • Fax: (763) 478-8080

Toll-Free: **1-800-328-2174**

Email: [help@tolomatic.com](mailto:help@tolomatic.com) • <http://www.tolomatic.com>

THK and Caged Ball are registered trademarks of THK Co. Ltd.; [www.thk.com](http://www.thk.com). All brand and product names are trademarks or registered trademarks of their respective owners. Information in this document is believed accurate at time of printing. However, Tolomatic assumes no responsibility for its use or for any errors that may appear in this document. Tolomatic reserves the right to change the design or operation of the equipment described herein and any associated motion products without notice. Information in this document is subject to change without notice.

Visit [www.tolomatic.com](http://www.tolomatic.com) for the most up-to-date technical information

