

ACE

®

World leader in deceleration technology

LOCKED SERIES

*Pneumatic Safety Clamping Products
for Linear Rail Systems, Guideways, & Rods*

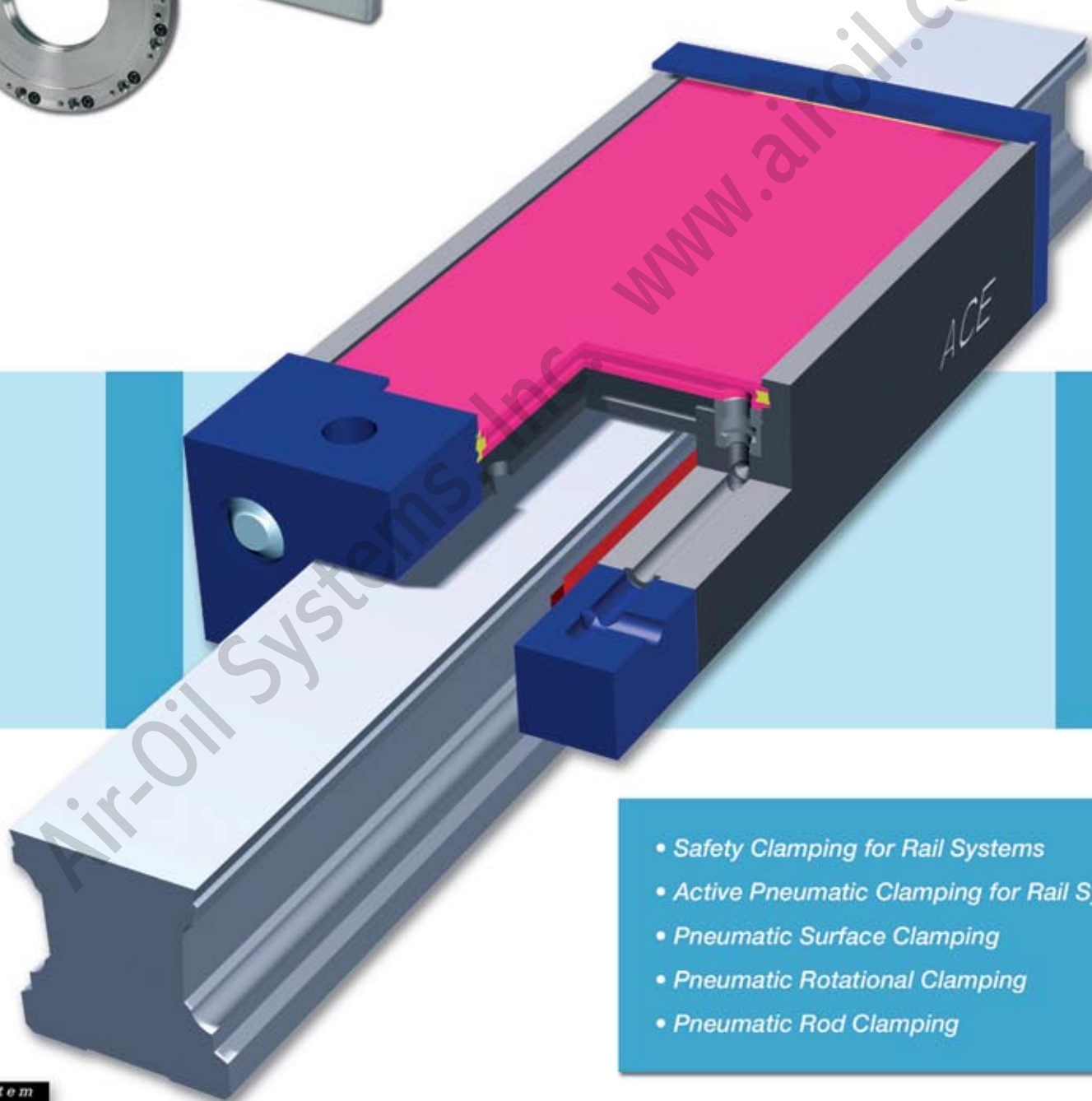
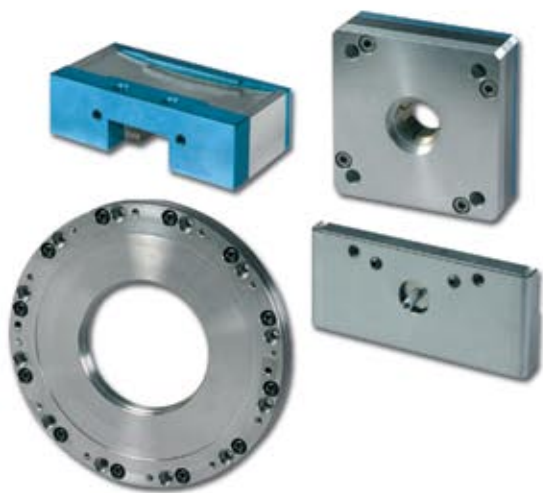

- Safety Clamping for Rail Systems
- Active Pneumatic Clamping for Rail Systems
- Pneumatic Surface Clamping
- Pneumatic Rotational Clamping
- Pneumatic Rod Clamping



Lowering machinery process costs is key in today's world. According to a recent study approximately a third of all machine stoppages result in unexpected damage and necessitate extensive repairs. This can be costly to you, resulting in downtime and lost production. ACE Controls now offers a series of products, titled the LOCKED SERIES, specifically designed to lower machine process costs and increase service life as well as operational safety.

Machine Failures

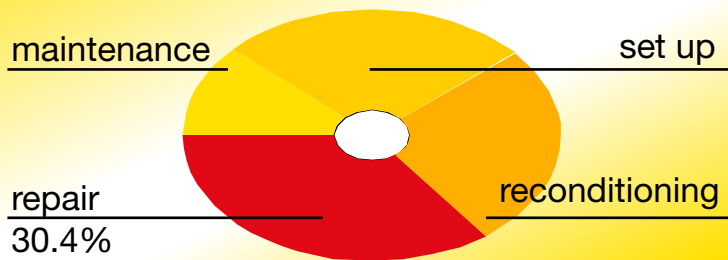

The installation of ACE LOCKED SERIES safety clamping products decreases the forces occurring when problems such as, power failure, programming error, erroneous switching or other problems occur.

All elements of the ACE Controls emergency stops are independent of the power supply and are not dependent on any part of the machinery that they protect and thus act as an independent brake system for the respective drives.

The clamping elements react in the shortest possible response time, due to the patented pneumatic pre-loading of the system by spring plates in the diaphragm. These safety systems are permanently operational for maximum machine protection.

This catalog focuses on the challenges of this area of applications for emergency stops and supplements the other ACE safety products such as the stacker crane and crane bumper industrial shock absorbers.

The following pages offer solutions for clamping and braking moving masses on rail systems, guideways, and rods. LOCKED SERIES Type L clamping elements offer the highest clamping forces in the most compact design for rail systems. LOCKED SERIES Type P offers pneumatic rod clamping in both directions of movement for rod diameters of 16 mm up to 50 mm. LOCKED SERIES Type R offers the highest forces and holding for clamping of rotational movements directly on the shafts from 50 to 340 mm.

Specifications subject to change without prior notice.

Example

Z-axis secured with ACE LOCKED SERIES Type L clamping elements and SCS safety shock absorber

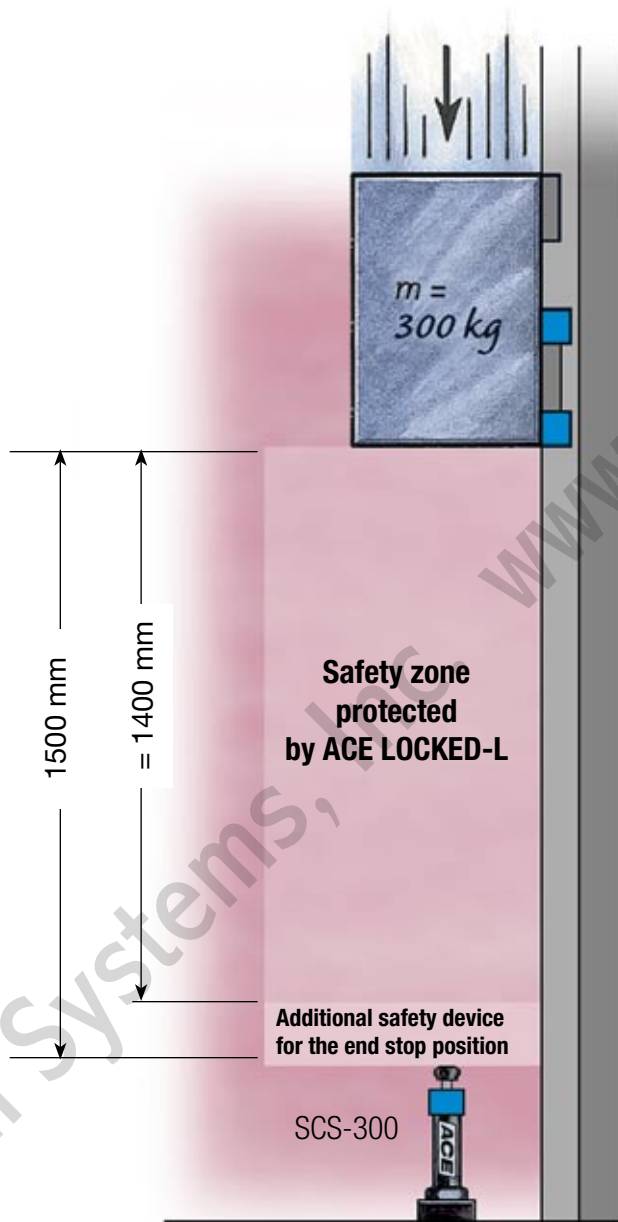

In the example shown above the final 1500 mm linear travel of the carriage is protected by the use of two ACE LOCKED Type L clamping elements. If automatic clamping of the axis, eg. by a power failure, is not available then the free falling mass of 300 kg is braked safely in a stopping distance of approx. 100 mm. This stopping distance is additionally protected at the end position by a small safety shock absorber from ACE Controls.

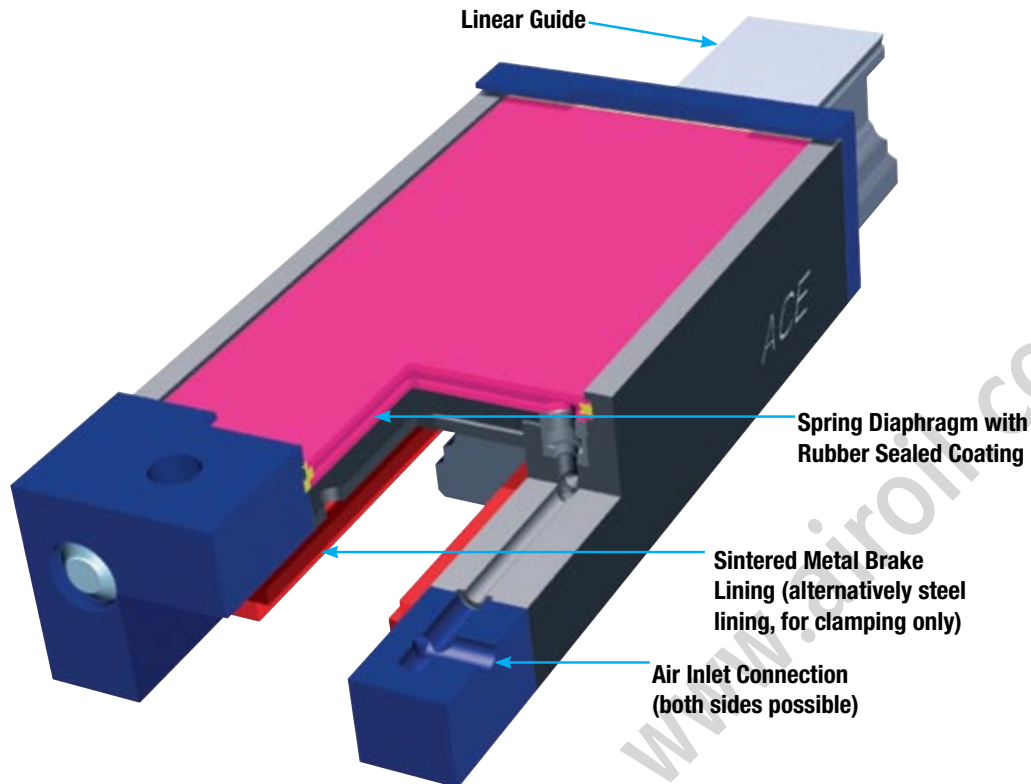

The innovative pneumatic clamping elements of the new ACE LOCKED SERIES Type-L offer a safe clamp/or brake system fitted directly on the guided rail. They are suitable for the majority of all rail sizes and manufacturers, such as INA, STAR/Rexroth, THK, Schneeberger and many others.

The compact construction method makes the assembly user friendly and available for large and wide carriages.

Despite the small physical size and low installation costs compared with equivalent hydraulic and electronic solutions, the highest clamping and braking forces are available, up to 10,000 N.

The ACE clamping system offers optimal safety braking, because the loss of pneumatic power immediately applies the clamping elements.

Rail sizes: 15 to 65 mm

Minimum holding forces: 900 to 10,000 N (6 bar type)

Clamping cycles/emergency use: 100,000/500 (for higher values please consult ACE)

Material: Clamping body and milled parts: tool steel; spring steel plate: spring steel; brake pads: sintered bronze or steel.

Mounting: In any position.

Operating pressure: 4 bar or 6 bar (standard type)

Pneumatic medium: Dried filtered air.

Operating temperature range: 15 to 45°C

On request: Wipers, special profiles and removing kit.



Design and Function

ACE LOCKED SERIES Type L Released

The chamber between the two flexible spring steel diaphragms is filled with compressed air. The spring plates deform and the horizontal dimension shortens. This causes the clamp shoe mounting plates to move away from the rail, releasing the clamps and permitting free movement.

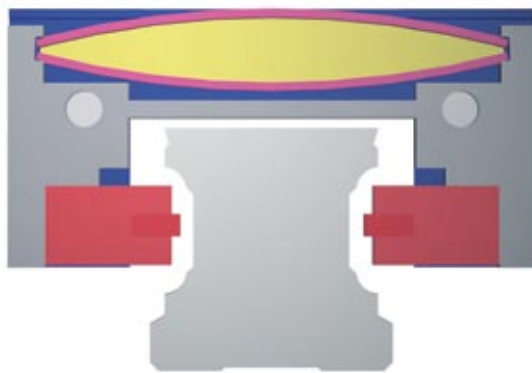

Example: STAR/Rexroth-installation

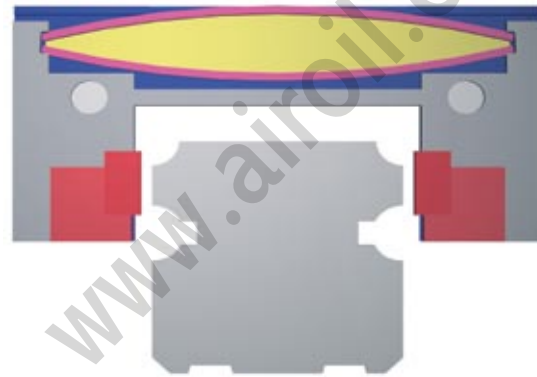

Example: NSK-installation

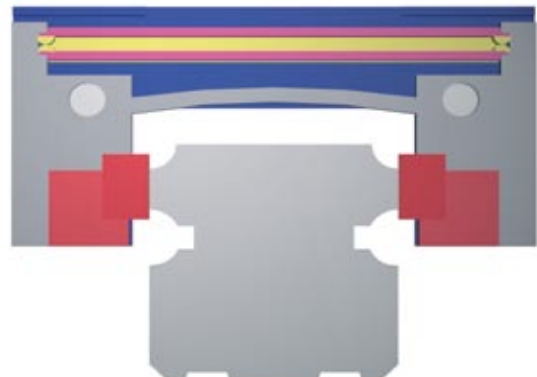
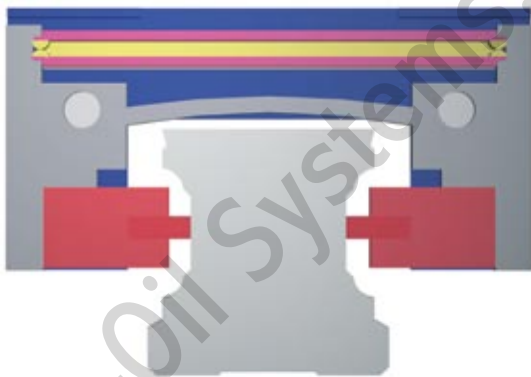

ACE LOCKED SERIES Type L Engaged

The compressed air in the chamber between the two flexible spring steel diaphragms is released. The spring plates return to their original position increasing the horizontal dimension. This causes the clamp mounts to move towards the rail, applying the clamping shoe.

Part Number LC

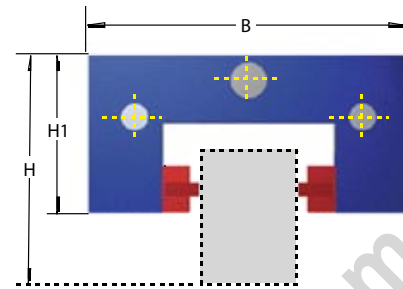
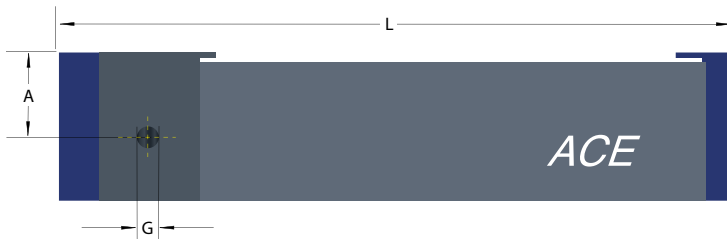

Starting with rail size 45, we recommend the use of a second holding block. Prices and dimensions on request.

6

Ordering Example:

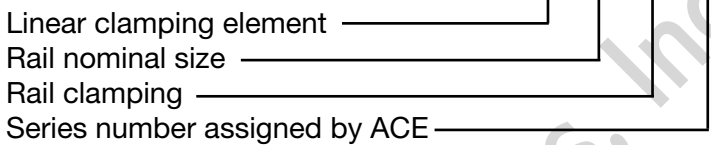

Complete Details Required when Ordering:

- Rail manufacturer, rail type, rail size
- Carriage type (height/width)
- Number of clamping cycles per hour
- Operating mode (dry, oiled, greased)
- Name of oil or grease

The calculation and selection of the correct clamping device should be made or approved by ACE. To assist you, please use the request form on page 13. For general information see page 11.

Dimensions (mm) and Capacity Chart:

Type Part Number	L	B	H	H1 high carriage	A	H	H1 low carriage	A	B1	C	G	M	Holding Force* N	Weight kg
LC-20-S	97.5	43	30	19.5	13.5	30	19.5	13.5	6	15	M5	M5	900	0.32
LC 25-S	117.5	47	40	29	19.5	36	25	15.5	6	20	M5	M6	1200	0.50
LC 30-S	126.5	59	45	32.5	20	42	29.5	17	10	24	M5	M8	1800	0.90
LC 35-S	156.5	69	55	42	29.5	48	35	22.5	10	24	1/8"	M8	2800	1.26
LC 45-S	176.5	80	70	52	36.5	60	42	26.5	10	26	1/8"	M10	4000	2.30
LC 55-S	202.5	98	80	59	38	70	49	28	12.5	30	1/8"	M12	6000	3.90
LC 65-S	259.5	120	100	74	48	90	64	38	15	40	1/4"	M12	10000	5.00

* The holding forces as shown in the capacity chart were determined on **dry rails** for roller systems. Different holding forces may occur for other rails. Depending on the grease used, calculate with **60% of the indicated holding forces** on greased rails. Special pads with full holding forces to clamp (not brake) on greased rails are available. Release of the clamping is actioned by an operating pressure of 5.5 to 6 bar; different operating pressures on request.

Part Number LC

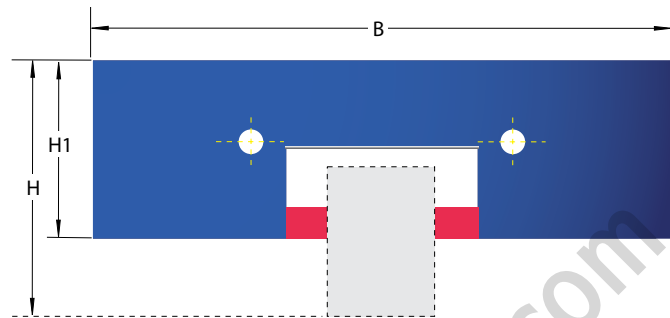
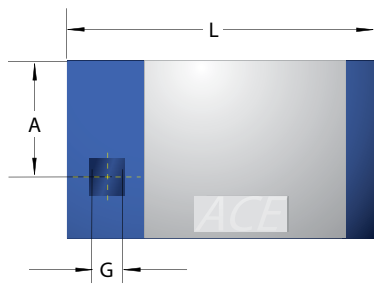

Ordering Example:
 Linear clamping element ————> LC
 Rail nominal size ————> 25
 Rail clamping Compact ————> SK
 Series number assigned by ACE ————> X

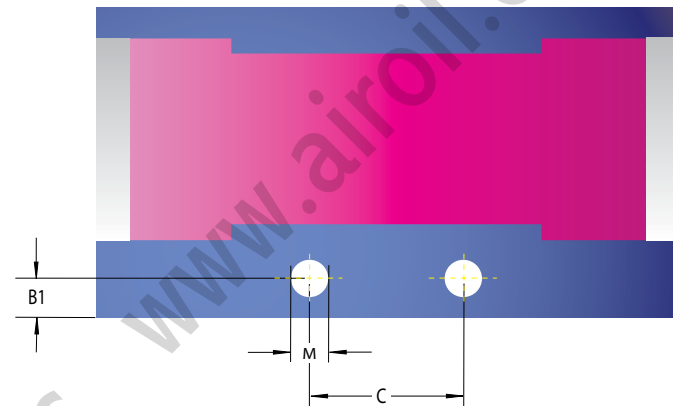

Complete Details Required when Ordering:

- Rail manufacturer, rail type, rail size
- Carriage type (height/width)
- Number of clamping cycles per hour
- Operating mode (dry, oiled, greased)
- Name of oil or grease

The calculation and selection of the correct clamping device should be made or approved by ACE. To assist you, please use the request form on page 13. For general information see page 11.

Dimensions (mm) and Capacity Chart:

Type Part Number	L	B	low carriage		high carriage		A	B1	C	G	M	Holding Force* N	Weight kg
			H	H1	H	H1							
LC-15-SK	55.5	45	24	20.5	--	--	14	5	15	M5	M4	450	0.50
LC 20-SK	55.5	54	30	25	--	--	16	5	20	M5	M6	650	0.60
LC 25-SK	55.5	75	36	32.5	40	36.5	16	5	20	M5	M6	750	0.70
LC 30-SK	67	82	42	30	45	33	21	8.75	22	M5	M8	1150	0.90
LC 35-SK	67	96	48	40	55	47	20	8.75	24	G1/8	M8	1250	1.27

* The holding forces as shown in the capacity chart were determined on **dry rails** for roller systems. Different holding forces may occur for other rails. Depending on the grease used, calculate with **60% of the indicated holding forces** on greased rails. Special pads with full holding forces to clamp (not brake) on greased rails are available. Release of the clamping is actioned by an operating pressure of 5.5 to 6 bar; different operating pressures on request.

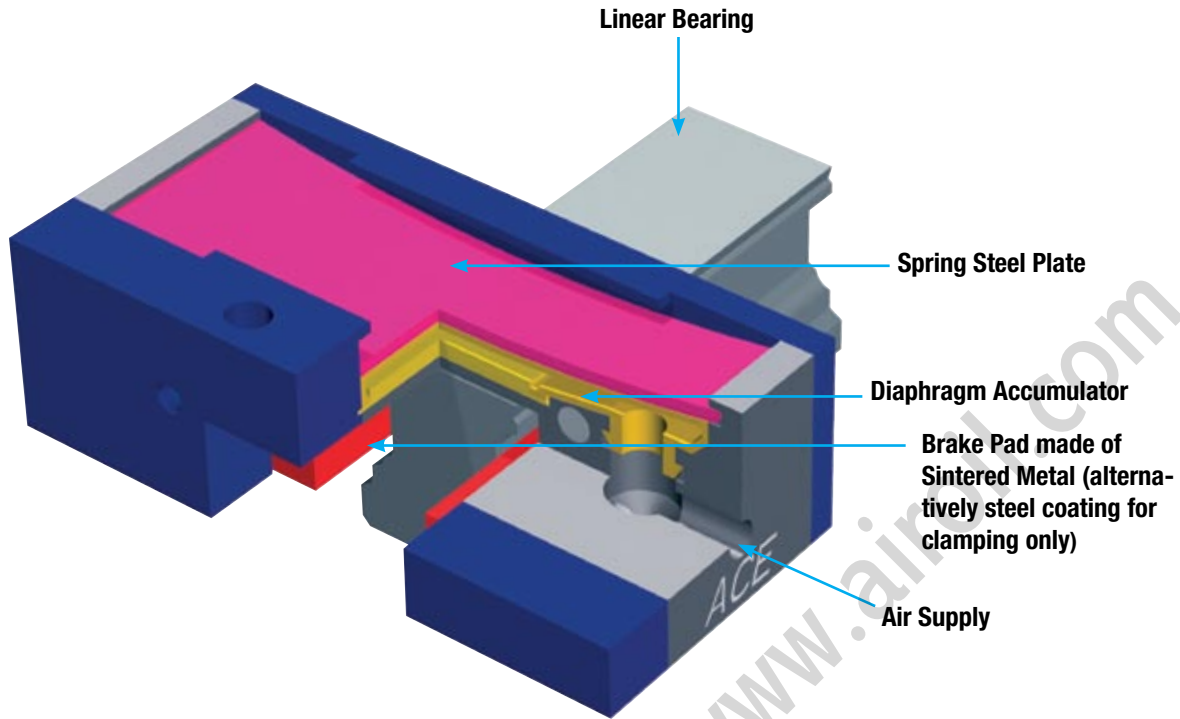

8

These new clamping elements of the ACE LOCKED SERIES Type-L Active offer the highest clamping forces in the most compact design.

Rapid clamping is possible due to reaction free pneumatic operation.

With an installation length of only 40 mm the largest clamping forces are possible, up to 800 N.

Rail sizes: 20, 25 and 35 mm
(further sizes planned)

Maximum holding forces: up to 1250 N
(6 bar type)

Clamping cycles/emergency use: 100,000/500 (for higher values please consult ACE)

Material: Clamping body and milled parts: tool steel; spring steel plate: spring steel; brake pads: sintered bronze or steel.

Mounting: In any position.

Operating Pressure: 4 bar or 6 bar
(standard type)

Pneumatic medium: Dried filtered air.

Operating temperature range: 15 to 45°C

On request: Wipers and special profiles.

The large surface area of the brake ensures a long working life. Both clamping and braking are possible with this model.

The simple design, low number of components, and pneumatic connection technology result in very low costs.

These active clamping elements can be applied in almost all standard rail systems.

Customized special sizes for the wood working and automation industries are offered on request.



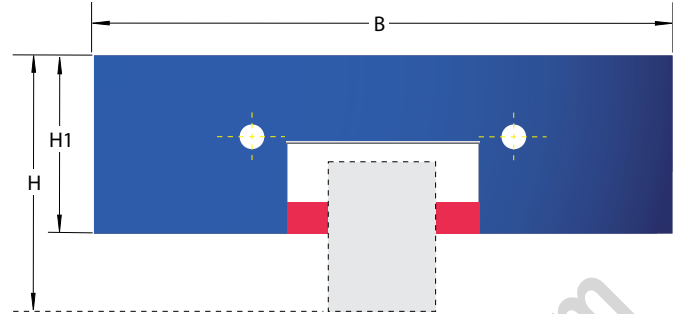
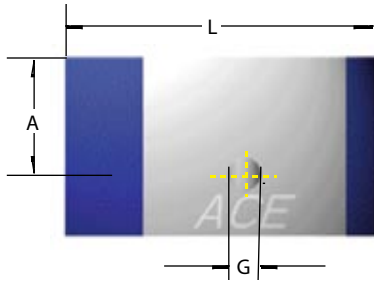

Ordering Example:

Linear clamping element ————
 Rail nominal size ————
 Rail clamping Active ————
 Series number assigned by ACE ————

LC 25 - SA - X

Complete Details Required when Ordering:

Rail manufacturer, rail type, rail size
 Carriage type (height/width)
 Number of clamping cycles per hour
 Operating mode (dry, oiled, greased)
 Name of oil or grease

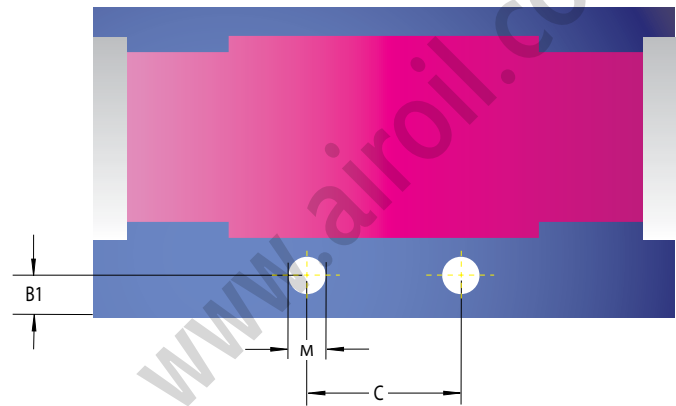

Functional Description and Instruction:

To activate the clamping, the membrane accumulator underneath the spring steel plate is filled with compressed air. The pre-tensioned spring steel plate is pushed upwards and stretched at the same time. The cross bar serves as pivot point and operates against a taper on the lower part of the clamping body. The brake pads are thereby pressed against the rails and the clamping is active.

To release the clamping, the membrane accumulator must be depressurized. The spring steel plate snaps back and pushes the clamp body underneath the cross bar. Now the previously elastically deformed clamp body can snap back into its initial position. This removes the tapered body off the cross bar and widens the gap underneath it. The brake pads lift off the rails.

The calculation and selection of the correct clamping device should be made or approved by ACE. To assist you, please use the request form on page 13. For general information see page 11.

Dimensions (mm) and Capacity Chart:

Type Part Number	L	B	low carriage		high carriage		A	B1	C	G	M	Holding Force* N	Weight kg
			H	H1	H	H1							
LC-20-SA	40	75	30	23	--		15	5	20	M5	M6	650	0.33
LC 25-SA	40	75	36	23	40	27	15	5	20	M5	M6	800	0.35
LC 35-SA	67	96	48	35	55	32	20	8.75	20	G 1/8	M8	1250	0.65

* The holding forces as shown in the capacity chart were determined on **dry rails** for roller systems (STAR, INA). Different holding forces may occur for other rail systems. Depending on the grease used, calculate with **60% of the indicated holding forces** on greased rails. Special pads with full holding forces to clamping (not braking) on greased rails are available.

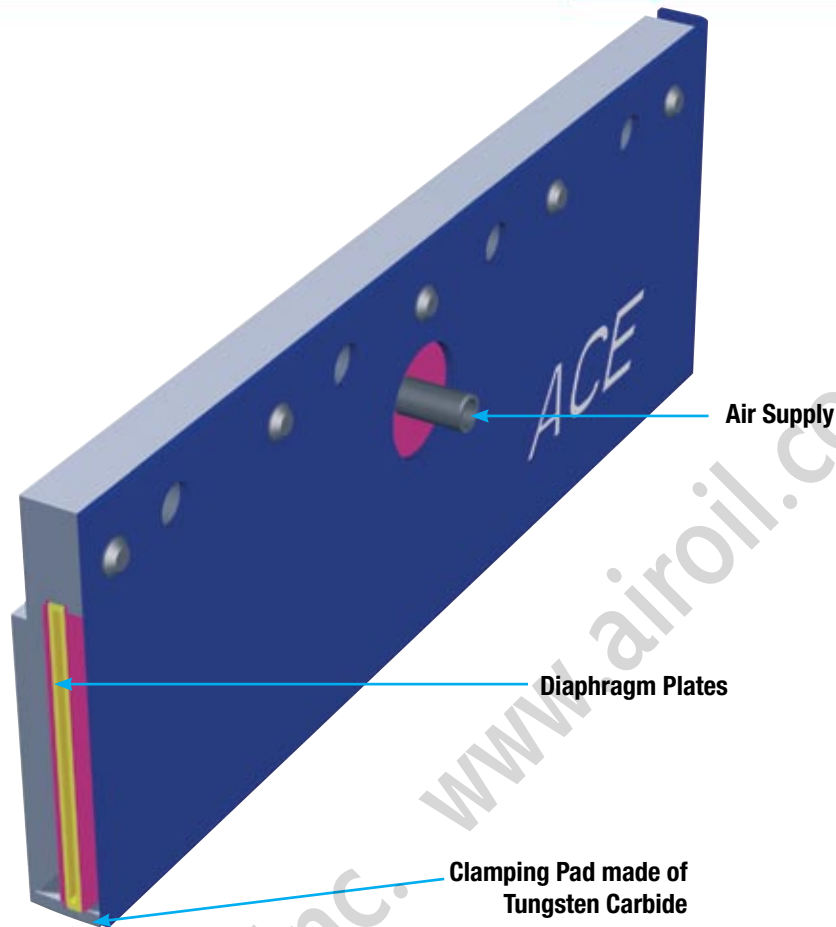

The extension unit LOCKED SERIES Type L from ACE enables pneumatic clamping adjacent to the precision rail.

The ACE LOCKED SERIES Type L extension units are identical for all standard rail manufacturers.

Due to the side mounting at the carriage, the need for mounting space is minimized.

This, in comparison to other systems, is a cost effective alternative offering medium clamping forces of up to 800 N.

A spring-brake actuator assures safe and secure clamping in case of a power failure. This clamping element can also be used for rails with a measuring system.

Rail Sizes: 25 and 35 mm (45 mm planned)

Minimum holding forces: up to 800 N

Clamping cycles: 10,000 (for higher values please consult ACE)

Material: Clamp body and milled parts: tool steel; spring steel plate: spring steel; brake pads: sintered bronze or steel.

Mounting: In any position.

Operating Pressure: 4 bar

Pneumatic medium: Dried filtered air.

Operating temperature range: 15 to 45°C



Operational Principle

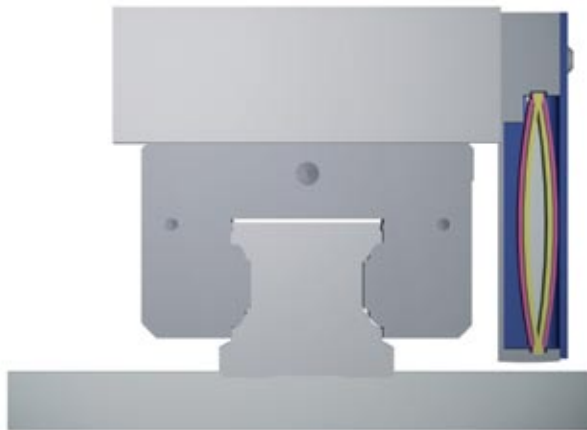

LOCKED-L Extension Released

The chamber between the two spring-steel diaphragms is filled with compressed air, so that the spring plates are elastically deformed and the whole system contracts. Due to contraction, the brake plate moves upwards and the carriage can move freely.

The space between brake plate and base at 5 bar is approx. 0.05 mm. Due to the accuracy of the precision rails, the distance between carriage and base is very stable, and the space of 0.05 mm is suitable.

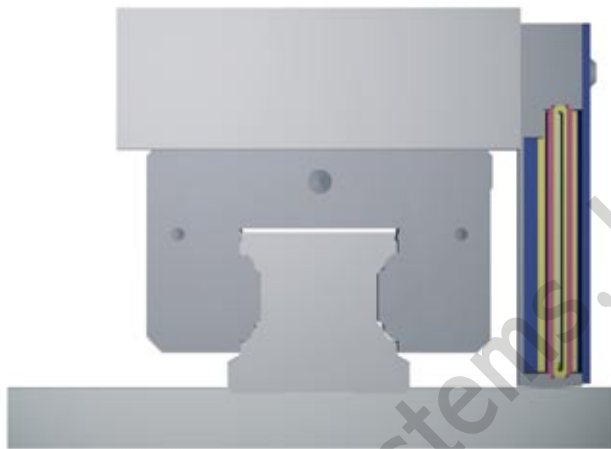

LOCKED-L Extension Engaged

The air pressure in the chamber between the two spring-steel diaphragms is released. The energy accumulated in the spring plates causes an expansion of the brake elements on to the machine base.

When the brake plates contact the base, a large part of the energy is still present in the spring brake actuator. The carriage is clamped tightly.

General Information for ACE LOCKED SERIES

- Exceeding the permissible operating pressure may lead to damage of the clamping unit.
- Clamping units are not designed to secure floating loads.
- Dirt, oil, and grease on the surface of the brake plates and the system affect the holding forces.
- Clamping elements may only be used according to technical specifications.
- The chosen compressed air is to be maintained throughout the entire service life.
- Regulations of the BG or other controlling institutes as well as technical regulations are to be adhered to.

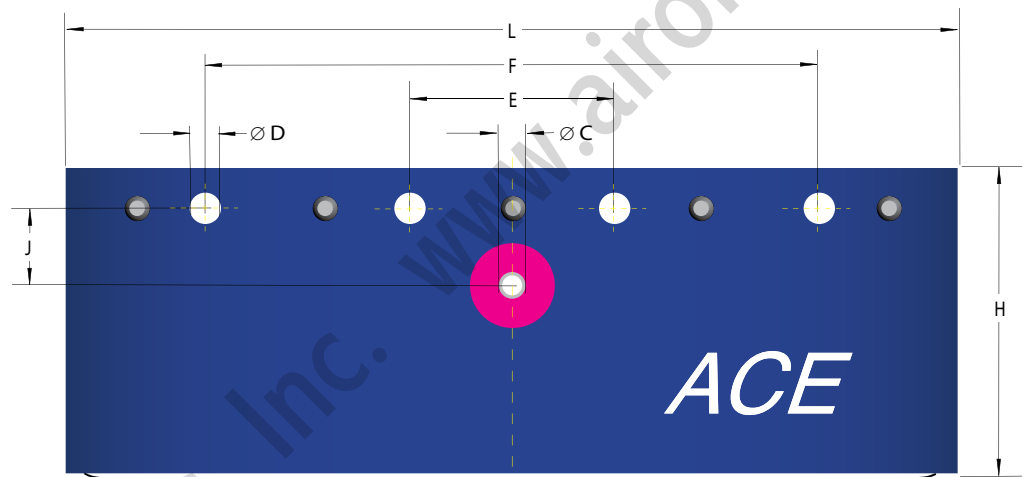
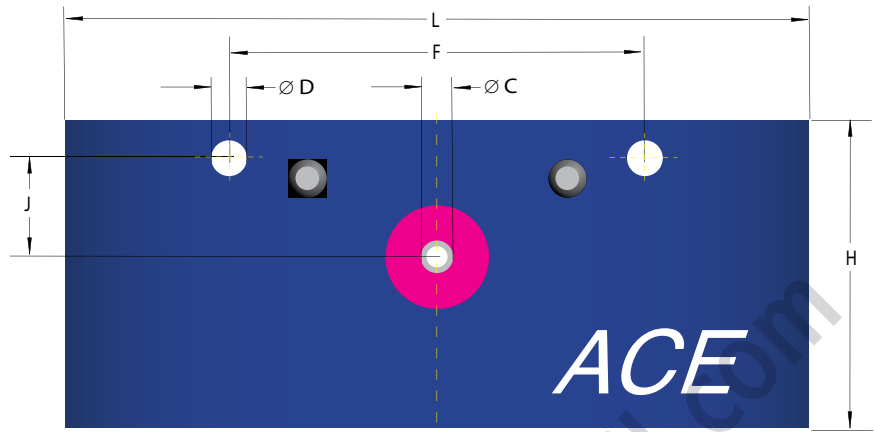
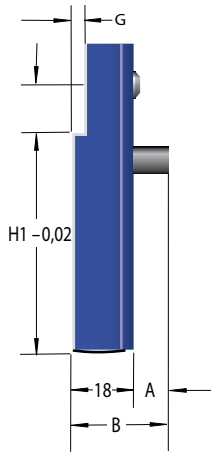

12

Ordering Example:

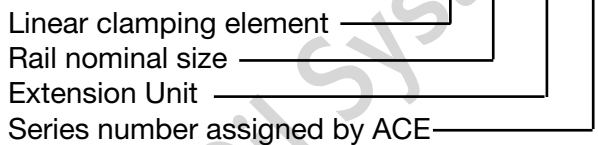

Complete Details Required when Ordering:

- Opening pressure
- Drilling template with drawing, if different
- Rail manufacturer, rail type, rail size
- Carriage type (height/width)

Dimensions (mm) and Capacity Chart:

Type Part Number	L	B	H	H1	A	C	D	E	F	G	I	J	Holding Force* N	Weight kg
LC-25-A	140	28.15	60	36	17	4	6.8		80	3.5	17	19	500	0.55
LC 35-A	212	29.45	81	55	19	8	6.8	50	150	3.5	14	22	800	1.15

* The stated holding forces are dependent on clamping area, and the clamp material pairing and can only be taken as an approximate reference value. Releasing of the clamping takes place at an operating pressure of 4 bar.

Frequently asked questions for your LOCKED SERIES Type L solution

ACE LOCKED SERIES Type-L rail clamping systems can be individually adjusted according to the application.

The data on the right will determine the system's configuration. Please fill in the information as fully as possible to find the best solution for your application.

Application horizontal vertical (with PLC) vertical (free fall)

System must engage with air release with air

Holding force _____ Newton Air pressure _____ bar

Required stop _____ mm Reaction time system _____ sec.

Application

as brake system emergency brake fall arrester
 clamping system for positional clamping process clamp positional clamping when moving

Clamping cycles/hour _____ Moving load _____ kg

Required minimum life time _____ (no. of clamping cycles)

Operating mode dry oiled greased

Exact name of oil/grease _____

Rail manufacturer, model, size _____

Carriage model (height, width) _____

Clamping used so far/comparison model _____

Special requirements _____

Quantity/year _____

Sender _____

Company _____

Address _____

Department _____

Name/position _____

Telephone _____

Fax _____

E-Mail _____

**Please copy, complete and fax to ACE Controls:
 Fax 248-476-2470**



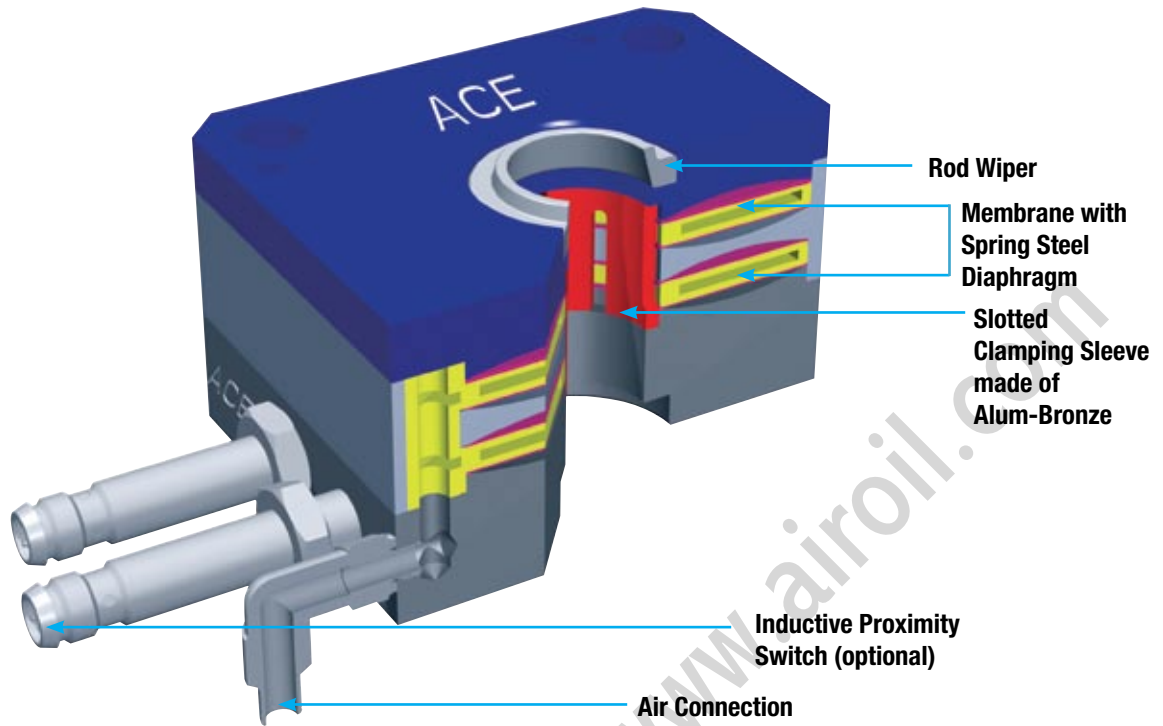

14

The innovative LOCKED SERIES Type P offers pneumatic rod clamping in both directions of movement for rod diameters of 16 mm up to 50 mm. The values of hydraulic clamping are met and exceeded at holding forces of up to 27,000 N.

LOCKED-P is the optimum method of safety clamping since pneumatic failure means immediate clamping of the system.

ACE LOCKED SERIES Type P is compact in design when compared to hydraulic systems.

Because of the modular design, several segments can be added on top of one another, and it is therefore possible to design the required clamping force for each individual application.

Dimensions of base/cover plates and flange diameters match those of ISO Pneumatic Cylinders.

Within the LOCKED SERIES Type P, ACE also offers a model with additional safety for the highest possible safety standards in relation to the vertical axes. After clamping of the piston rod, the clamping can only be released again when the axis is driven vertically upwards.

Rod diameter: 16 to 50 mm
(hardened piston rod recommended)

Holding forces: up to 27,000 N

Clamping cycles: 100,000
(for higher values please consult ACE)

Material: Clamping body and milled parts: tool steel;
spring steel plates: spring steel.

Operating pressure: 4 bar (automotive) or 6 bar

Pressure medium: Dried filtered air.

Operating temperature range: 10 to 45°C



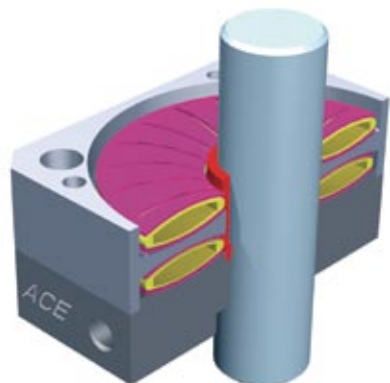

LOCKED-P Released

The chambers between the spring steel diaphragms are filled with compressed air. The diaphragms are elastically deformed and at the same time shortened in the radial direction. Since the spring steel diaphragms are slotted in the inner diameter, the diameter enlarges, the clamping sleeve springs radially outwards, and the rod is released.

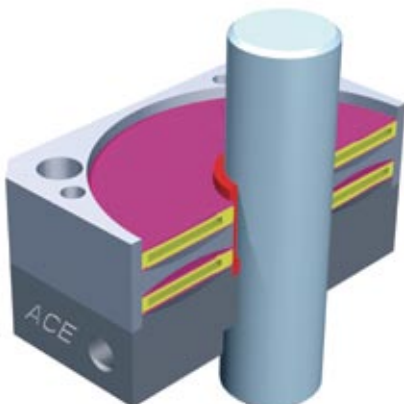

LOCKED-P Activated

The air pressure in the chamber between the spring steel diaphragms is released. The diaphragms spring back into their normal position. They press the slotted clamping sleeve against the rod, thereby clamping against it. This ensures optimum safety clamping.

Models LOCKED-P

Standard model ACE LOCKED-P

The ACE LOCKED-P standard model is the basis for the entire range. The basic function, as described above, is found in all models. The body dimensions and the bore sizes are designed to suit the individual pneumatic cylinder types. This model range is highly flexible due to the tiered bore diameters for corresponding rod diameters. In addition, this flexibility is increased by its intelligent modular design. The clamping force can be easily increased by applying several clamping units together. By arranging "X" number of clamping units between the base and cover plates, "X" times the clamping force can be obtained.

For the standard model, the corresponding nominal size for the following rod diameters are possible:

Nominal size 63 mm: 12 mm, 14 mm, 16 mm, 18 mm and 20 mm

Nominal size 80 mm: 16 mm, 18 mm, 20 mm, 22 mm, 24 mm and 25 mm

Nominal size 125 mm: 28 mm, 30 mm, 32 mm, 35 mm, 36 mm and 40 mm

ACE LOCKED-P model for ISO pneumatic cylinders

The base and cover plates for this model are matched to the flange dimensions of the corresponding ISO cylinders. Due to the difference with ISO cylinders, this model is constructed larger than the above described model. The corresponding dimensions can be taken from the data sheet on the next page. The middle clamping unit is identical to the standard model.

Note: The nominal stroke of the applicable ISO pneumatic cylinder is reduced according to the construction length of the clamping unit. End-of-travel damping is not applicable. Do not use LOCKED-P clamping elements as a positive stop!

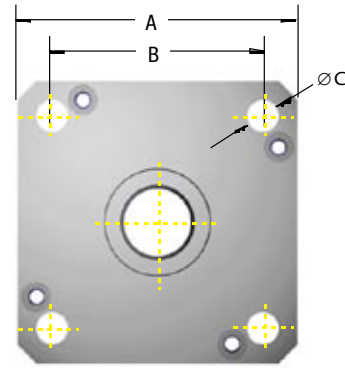
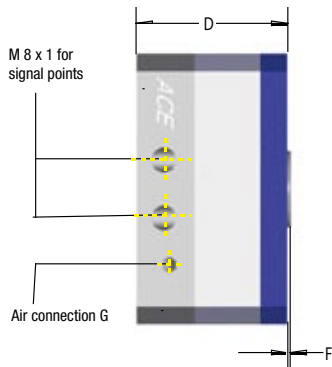

Version for ISO Cylinders

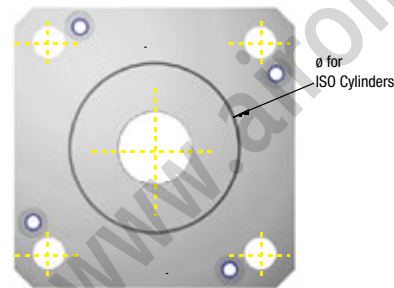
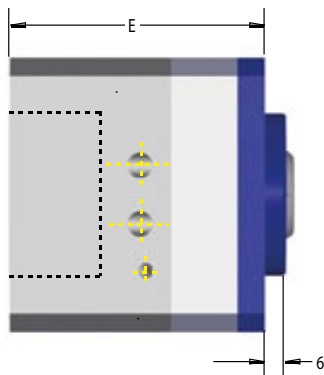

PC 80 - 25 - 1 - X

Ordering Example:

- Rod clamping element
- Cylinder nominal size 80 mm
- Rod diameter 25 mm
- Number of clamping units 1
- Series number is assigned by ACE

Complete Details Required when Ordering:

- Desired opening pressure
- Standard model or ISO Cylinder
- Number of clamping modules
- Required holding force
- Operating mode (dry, oiled, greased)

The calculation and selection of the correct clamping device should be made or approved by ACE. Use the request form on the next page.

Dimensions (mm) and Capacity Chart:

Type Part Number	A	B	C	D	E	F	G	Holding Force* Opening Pressure 4 bar N	Holding Force* Opening Pressure 6 bar N	Weight Standard ISO kg	
PC 63-20-1	75	56.5	8.5	41.5	67.5	2.1	M5	1400	2000	0.80	1.10
PC 63-20-2	75	56.5	8.5	59.5	85.5	2.1	M5	2520	3600	1.20	1.50
PC 63-20-3	75	56.5	8.5	77.5	103.5	2.1	M5	3780	5400	1.70	2.00
PC 80-25-1	96	72	10.5	49.5	73.5	2.14	G 1/8	2100	3000	1.30	1.80
PC 80-25-2	96	72	10.5	63.5	87.5	2.14	G 1/8	3780	5400	2.10	2.60
PC 80-25-3	96	72	10.5	83.5	107.5	2.14	G 1/8	5670	8100	2.90	3.40
PC 125-40-1	145	110	13	51.6	95.6	3	G 1/8	7000	10000	3.60	5.70
PC 125-40-2	145	110	13	75.2	119.2	3	G 1/8	12600	18000	5.60	7.70
PC 125-40-3	145	110	13	98.8	142.8	3	G 1/8	18900	27000	7.70	9.80

* The listed holding forces are reached under optimum conditions. We recommend a safety factor of > 10 %. Please note that surface, material and cleanliness of the rod as well as wear and tear and the use rod wipers set, lead to different holding forces. Test the clamping needed for series production or safety applications in its used application environment and measure the actual values.

**List of questions for your
LOCKED SERIES Type P
solution**

ACE LOCKED SERIES Type P systems can be adjusted to different applications individually. The criteria on the right decide the actual configuration of the system. Please enter the information as completely and with as much detail as possible to find a solution for your application.

Required LOCKED-P model accd. to chart _____

Standard air pressure (unrestricted system) 4 bar 6 bar

Application horizontal vertical (with PLC) vertical (free fall)

Desired clamping force _____ Newton No. of modules _____

Required stop _____mm Reaction time system _____ sec

Clamping cycles/hour _____ Moving load _____ kg

Required minimum life time _____ (no. of clamping cycles)

Operating mode dry oiled greased

Exact name of oil/grease _____

Piston rod diameter in mm _____

Manufacturer of cylinder _____

Model name _____

Special requirements _____

Quantity/year _____

Sender _____

Company _____

Address _____

Department _____

Name/position _____

Telephone _____

Fax _____

E-Mail _____

**Please copy, complete and fax to ACE Controls:
Fax 248-476-2470**



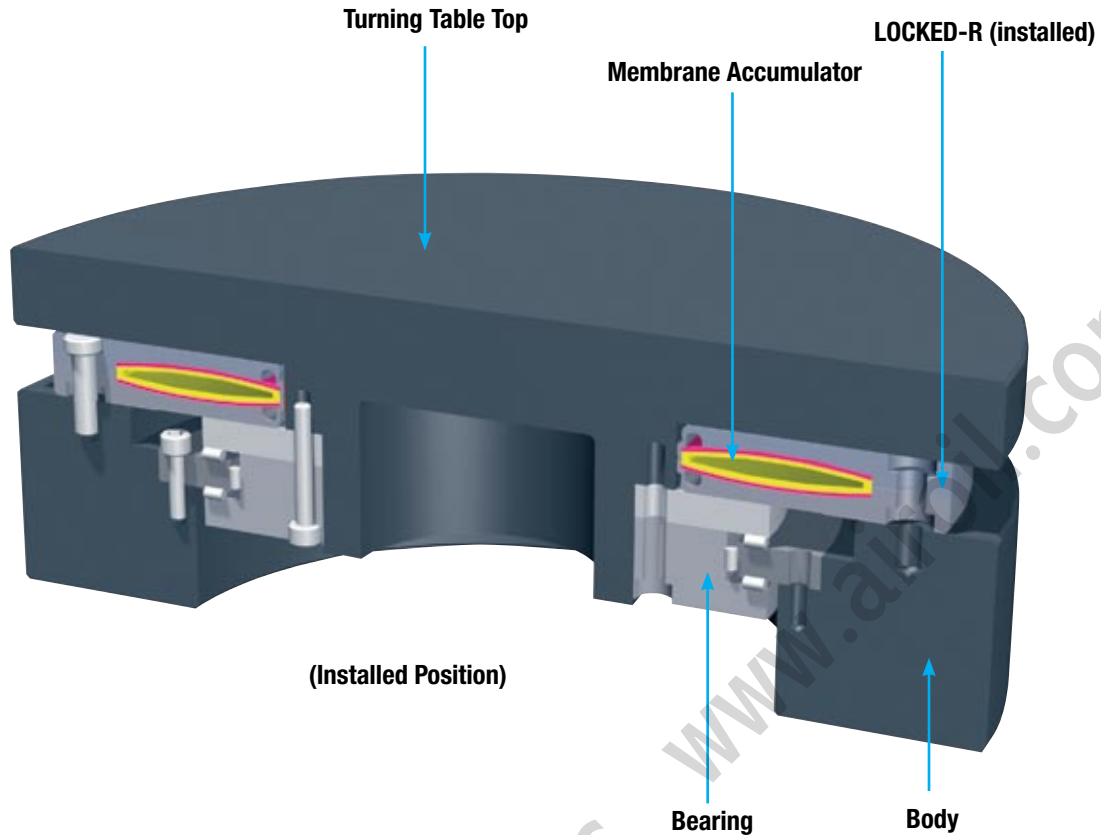

18

ACE's innovative pneumatic clamping elements of the LOCKED SERIES Type R offer the highest forces and holding for clamping of rotational movements directly on the shaft. They are available in standard sizes for shaft diameters of 50 to 340 mm. Due to the spring-brake actuator principle, energy failure is immediately followed by safety clamping.

As a result of the use of pneumatics, very short reaction times are reached. The use of Piezo valves directly at the clamping point allows for rapid clamping times. The costs when compared to hydraulic clamping systems, including safety clamping, are low.

ACE's LOCKED SERIES Type R clamping elements are compact in design and easy to install.

Shaft diameter: 50 to 340 mm
(on request up to 460 mm)

Maximum holding: 4300 Nm (up to 7800 Nm with additional compressed air)

Material: Clamping body hardened, inner bore ground.

Optionally fitting shaft flange: C45 standard or steel coated (Sliding fit)

Operating pressure: 5.5 to 6.5 bar (other values on request)

Pressure medium: Dried filtered air.



Operational Principle

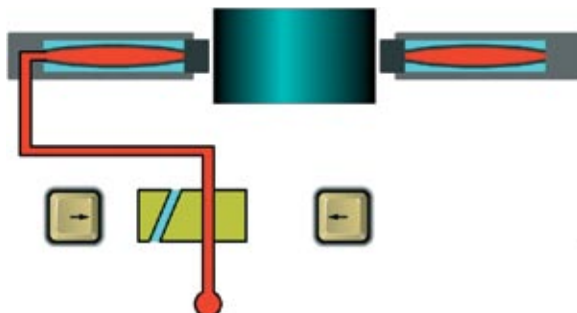

LOCKED-R Released

The chamber between the two ring-shaped spring steel membranes is filled with compressed air and the inside ring is thereby elastically expanded. Due to the resulting shape and the fact that the membranes are radially slotted outwardly at the inner diameter, the clamping can spring back to its original (released) position.

The enlargement of the diameters frees the shaft, and movement without resistance is possible. The increased diameter results from the tolerance between shaft and the LOCKED-R element.

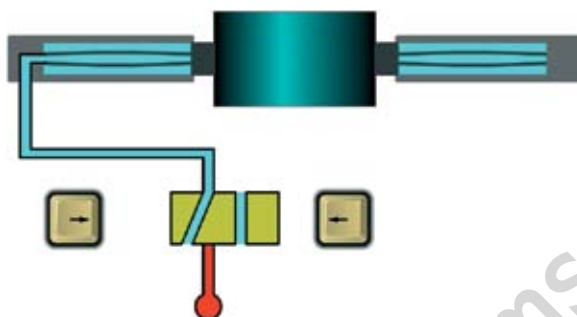

LOCKED-R Engaged

The air pressure in the chamber between both ring-shaped diaphragms is released. The diaphragms' return force presses the clamping surface back into contact with the shaft. The spring-brake actuator affects the clamping and needs no additional energy.

Air-Oil Systems, Inc. www.air-oil.com



Additional ACE Controls Products

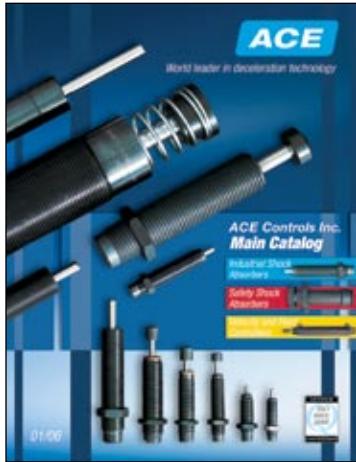

Industrial & Safety
Shock Absorbers
Velocity Controllers



Gas Springs &
Hydraulic Dampers

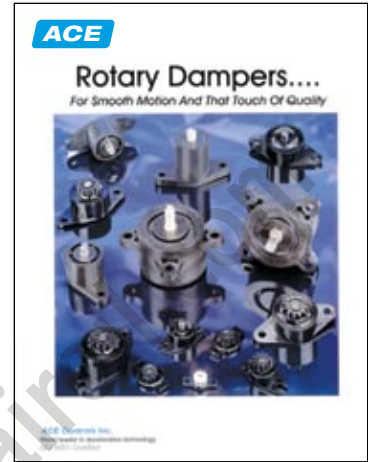

Rotary Dampers

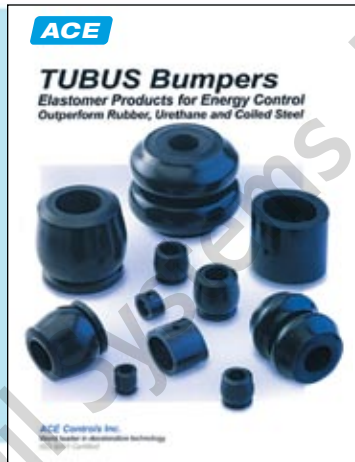

TUBUS Bumpers

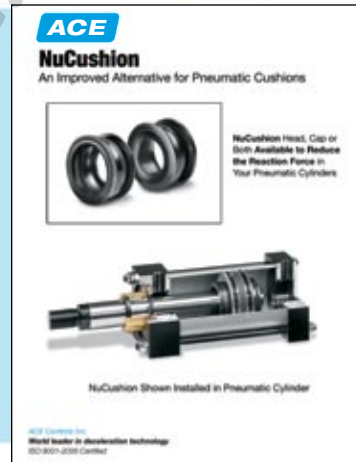

NuCushion
(Superior to
Pneumatic Cushions)

© ACE Controls Inc. 2007

23435 Industrial Park Drive Farmington Hills, MI 48335 • Phone: 800-521-3320 • Fax: 248-476-2470
Email: shocks@acecontrols.com • www.acecontrols.com