

# Compact Select Cylinders

---

## Inch Series



*Answer Engineering*  
**COMPACT**<sup>®</sup>  
AUTOMATION PRODUCTS LLC  
An **IMC** Company

# Table of Contents: Inch Series

## Inch Series, Options and Accessories

### Inch Series

How to Order: Inch Series .....	pg. 2
Forces, Pressure Ratings, Envelope Dimensions .....	pg. 3
Mounting .....	pgs. 4-6
Duty .....	pg. 7
Component Descriptions .....	pg. 8
<b>Dimensions</b>	
1/2" Bore Cylinder .....	pgs. 10-14
1/2" Bore Accessories .....	pgs. 15-20
3/4" - 8" Bore Cylinders .....	pgs. 21-70
3/4" - 8" Bore Accessories .....	pgs. 71-86
Sensors .....	pgs. 87-88
Alignment Couplers .....	pgs. 89-90
Flow Controls .....	pgs. 91-92
Technical Information .....	pgs. 93-96
Maintenance and Repair Kits .....	pgs. 97-98
Modified Products .....	pgs. 99-102

3-D Models available online at [www.compactautomation.com](http://www.compactautomation.com)



# How to Order: Inch Series

## Inch Series

Example: ASFHD118X1-FFHTV

MAGNETIC PISTON	MOUNTING STYLE	DUTY	DOUBLE ROD END	BORE SIZE		STROKE LENGTH	OPTION	OPTION
A	S	FH	D	118	X	1	XXX	XXX
1	2	3	4	5		6	7	8

**1**

Magnetic Piston (Optional)	
A	Magnetic piston cylinder with sensor mounting rail

NOTE: Leave blank for standard option.

**2**

Mounting Style	
S	Square, end mount
R	Round, end mount
B	Base, side mount
T	Thin, side mount

**3**

Duty (Optional)	
HH	Half Husky - Intermediate duty (available on single rod end only)
FH	Full Husky - Heavy duty

NOTE: Leave blank for standard option.

**4**

Double Rod End (Optional)	
D	Double rod end

**5**

Bore			
12	1/2"	212	2-1/2"
34	3/4"	3	3"
118	1-1/8"	4	4"
138	1-3/8"	5	5"
158	1-5/8"	6	6"
2	2"	8	8"

**6**

Stroke Length (Stroke lengths are available in 1/8" increments)	
See catalog pages for stroke availability for each bore size.	
Example: 1-1/8" = 118	
3/4" = 34	

**7**

Options (String option codes in alphabetical order to the right of the "-" including seal option)			
Mounting Options			
EB	End Bracket	SP	Short Pivot
FF	Front Flange	SRC	Short Rear Clevis
LP	Long Pivot	SRCE	Short Rear Clevis w/ Eye Mount
NM**	Nose Mount		
PS	Pivot Shaft	TBE	Threads Both Ends
RA	Reverse Assembly	TF	Threads Front
RF	Rear Flange	TM	Thru Mount
SB	Side Bracket	TR	Threads Rear
Rod End Options			
CBSS	Clevis Bracket Set Screw	HR1	Hollow Rod, Option 1
EX	Extension, Single Rod End	HR3	Hollow Rod, Option 3
EXD	Extension on Double Rod	MS/MSD	Male Stud/MS Double End
EXF	Front End Extension on Double Rod	NR*	Non-Rotating
		NT**	Jam Nut
EXR	Rear End Extension on Double Rod	RE	Rod Eye
		RES	Rod Eye, short head design
FT	Fine Threads	RW/RWD	Rod Wiper/Rod Wiper Double End
Other			
ADJ	Adjustable Retract Stroke	UB3	Urethane Bumper - Both ends
PA	Positive Alignment	UC1	Urethane Cushion - Front end
UB1	Urethane Bumper - Front end	UC2	Urethane Cushion - Rear end
UB2	Urethane Bumper - Rear end	UC3	Urethane Cushion - Both ends
Ports			
18NPT	1/8" National Pipe Thread Fine	14NPT	1/4" National Pipe Thread Fine

\*NOTE: See Non-Rotating option on page 78.

\*\*NOTE: See Nose Mount option page 86.

**8**

Seal Option		
Standard Buna-N 0° - 200°F (-18° - 93°C)		
Optional Seals		
Pneumatic		
HTV	High temperature viton	0° - 400°F (-18° - 204°C)
CRT*	Corrosion resistant Not recommended for use under 250° F	250° - 400°F (121° - 204°C)
ETP	Ethylene Propylene	-70° - 300°F (-57° - 150°C)
Hydraulic		
HYD*	Buna-N hydraulic	0° - 250°F (-18° - 121°C)
VHYD*	Viton hydraulic	0° - 400°F (-18° - 204°C)

\*NOTE: Not available in 1/2" bore.

### CR3 - Corrosion Resistant 300 Series Stainless Steel

Specify before part number.  
Available on 1/2 through 3".  
See pages 16 and 72 for details.

### Modifications Welcome

Special stroke lengths, port orientation, mounting configuration.

# Forces, Ratings & Envelope Dimensions

## Cylinder Force and Pressure Rating

**Formula:** Force (lbs.) = Piston Area (In<sup>2</sup>) x Pressure (PSI)

Example: 1.5 In<sup>2</sup> (Piston Area) x 150 PSI (Pressure) = 225 lbs. Force

Bore	Piston Area (In <sup>2</sup> )	Pre-Calculated Force in Pounds			Pressure Rating (PSI)	
		60 PSI	80 PSI	100 PSI	Pneumatic	Hydraulic
1/2	Push .2	12	16	20	125	-
	Pull .15	9	12	15		
3/4	Push .44	26	35	44	250	500
	Pull .36	22	29	36		
1-1/8	Push 1.0	60	80	100	250	500
	Pull .8	48	64	80		
1-3/8	Push 1.5	90	120	150	250	500
	Pull 1.2	72	96	120		
1-5/8	Push 2.0	120	160	200	250	500
	Pull 1.7	102	136	170		
2	Push 3.1	186	248	310	250	500
	Pull 2.8	168	224	280		
2-1/2	Push 4.9	294	392	490	250	500
	Pull 4.5	270	360	450		
3	Push 7.0	420	560	700	250	500
	Pull 6.6	396	528	660		
4	Push 12.6	756	1008	1260	200	200
	Pull 12.1	726	968	1210		
5	Push 19.6	1176	1568	1960	200	-
	Pull 19.2	1152	1536	1920		
5" FH	Pull 18.8	1128	1504	1880		
6	Push 28.3	1698	2264	2830	200	-
	Pull 27.5	1650	2200	2750		
8	Push 50.3	3018	4024	5030	200	-
	Pull 49.5	2970	3960	4950		

### Conversions

#### PSI to BAR

1 PSI = 0,069 bar

Example: 25 PSI X 0,069 = 1.73 BAR

#### Pound to Kilograms

1 pound = 0,45 kilograms

Example: 5 lbs. x 0,45 = 2,25 kilograms

## Envelope Dimensions

Bore	A			S	D
	Standard	Intermediate	Heavy		
1/2	0.69	0.81	0.94	1.00 X .75	1.13
3/4	0.81	1.06	1.31	1.25 Sq.	1.50
1-1/8	0.88	1.13	1.38	1.50 Sq.	1.88
1-3/8	1.13	1.38	1.63	1.75 Sq.	2.13
1-5/8	1.13	1.38	1.63	2.00 Sq.	2.38
2	1.25	1.50	1.75	2.50 Sq.	3.00
2-1/2	1.38	1.63	1.88	3.00 Sq.	3.50
3	1.63	1.88	2.13	3.50 Sq.	4.00
4	1.75	2.00	2.25	-	5.00
5	1.88	2.13	2.38	-	6.00
6	2.13	-	-	-	7.00
8	2.38	-	-	-	9.00

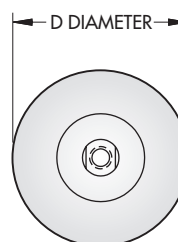
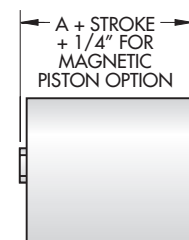
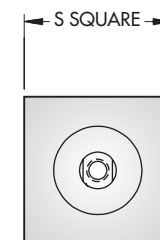

# Square - End Mount - Cylinder

## 1/2" through 3" Bore

### Non Magnetic Piston

Ordering Prefix **S**



### Magnetic Piston

Ordering Prefix **AS**

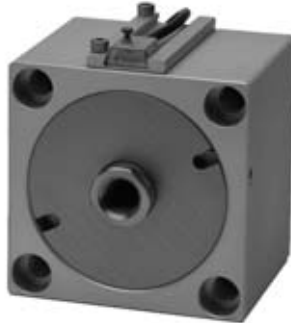

Icon represents mounting style on each dimensional page.

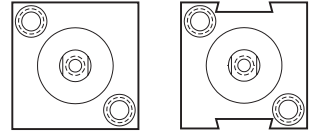

### Sensors Sold Separately

See Sensors pages 87-88

## Optional Mounting

Square - end mount - cylinders have one or more of the following patterns as standard.

**Each dimensional page lists standard and optional mounting suffix codes.**

### Threads Front

Standard on all cylinders

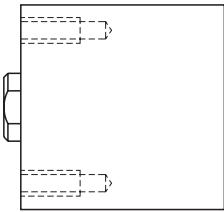

Tapped mounting holes on the rod end

### Threads Rear

Ordering Suffix **TR**

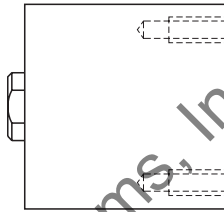

Tapped mounting holes opposite the rod end

### Threads Both Ends

Ordering Suffix **TBE**

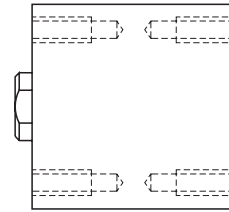

Tapped mounting holes on both ends

### Thru Mount

Ordering Suffix **TM**

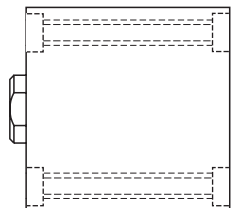

Counterbored mounting holes, both ends, for drop through bolt

Available on:

- 1/2" Bore through 1-1/8" **body** length
- 3/4" - 3" Bore through 2" **stroke** length

*For longer stroke lengths - Check mounting screw availability.*

Modifications welcome - consult factory.

Non magnetic piston cylinders - When 'TR' is specified or when using 'Bolt On Hardware' options, the cylinder may be reverse assembled, see Technical Data section page 93 for detailed explanation. To avoid changing port orientation, specify suffix: "TBE".



# Round - End Mount - Cylinder

## 1/2" through 8" Bore

**Non Magnetic Piston**  
Ordering Prefix **R**

**Magnetic Piston**  
Ordering Prefix **AR**

Icon represents mounting style on each dimensional page.

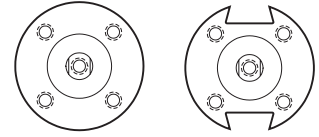

**Sensors Sold Separately**  
See Sensors pages 87-88



## Optional Mounting

Round - end mount - cylinders have one or more of the following patterns as standard.  
**Each dimensional page lists standard and optional mounting suffix codes.**

**Threads Front**  
Standard on all cylinders

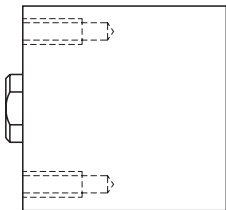

Tapped mounting holes on the rod end

**Threads Rear**  
Ordering Suffix **TR**

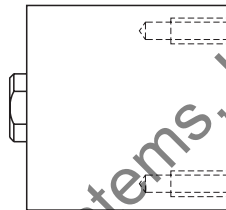

Tapped mounting holes opposite the rod end

**Threads Both Ends**  
Ordering Suffix **TBE**

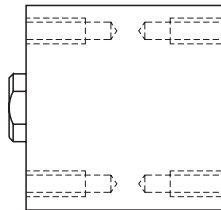

Tapped mounting holes on both ends

**Thru Mount**  
Ordering Suffix **TM**

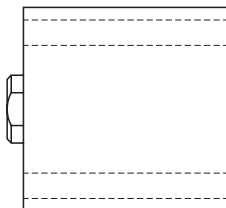

Thru mounting holes for drop through bolt

Available on:

- 3/4" - 8" Bore through 2" **stroke** length

*For longer stroke lengths - Check mounting screw availability.*

*Modifications welcome - consult factory.*

Non magnetic piston cylinders - When 'TR' is specified or when using 'Bolt On Hardware' options, the cylinder may be reverse assembled, see Technical Data section page 93 for detailed explanation. To avoid changing port orientation, specify suffix: "TBE".

# Base - Side Mount - Cylinder

## 1/2" through 3" Bore

**Non Magnetic Piston**  
Ordering Prefix **B**

**Magnetic Piston**  
Ordering Prefix **AB**

Icon represents mounting style on each dimensional page.

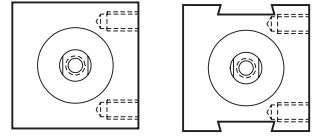

**Sensors Sold Separately**  
See sensors pages 87-88

## Optional Port Position

Base - side mount - cylinders have one standard mounting and port location, below are examples of optional positioning.

**1/2" Bore** Cylinder may be 'Reverse Assembled' consult factory - See Technical Data page 93 for detailed explanation.

### 3/4" through 3" Bore

- Non Magnetic Piston Cylinders** Optional positions are available as shown below:  
*COMPACT® reserves the right to plug existing ports, without notification, unless specified otherwise.*

**Standard Location**  
Example  
Side number 4

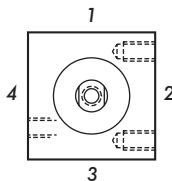

**Port Position 1**  
Example  
Ordering Suffix **PP1**

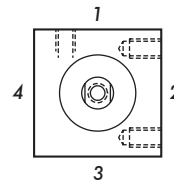

**Port Position 3**  
Example  
Ordering Suffix **PP3**

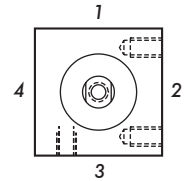

- Magnetic Piston Cylinders**  
Alternate port locations are available, consult factory for information.

# Thin - Side Mount - Cylinder

## 1/2" Bore Only

**Non Magnetic Piston**  
Ordering Prefix **T**

**Magnetic Piston**  
Ordering Prefix **AT**

Icon represents mounting style on each dimensional page.

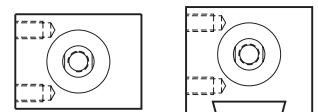

**Sensors Sold Separately**  
See Sensors pages 87-88

# Duty Types

## Double Acting COMPACT® Cylinders - Single and Double Rod End

### Standard Duty



#### COMPACT® Cylinders

Our most space efficient duty. Short rod bearing and thin piston design are for guided loads. Available as single or double rod end.

### Heavy Duty

Ordering Suffix **FH**



#### Full Husky®

Longer rod bearing plus thicker piston are for heavy duty service. Available as single or double rod end.

### Intermediate Duty

Ordering Suffix **HH**



#### Half Husky®

A combination of our standard and Full Husky duty. Long rod bearing and thin piston design are for medium duty service. Available as single rod end only.

## Components and Material

### Standard Duty

Single Rod End

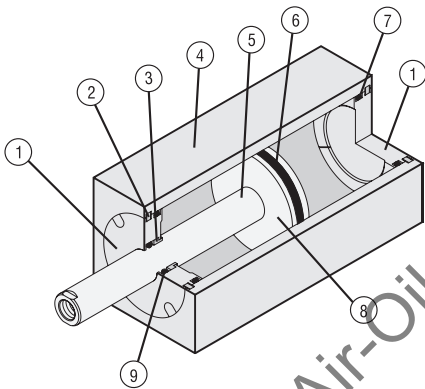

### Heavy Duty

Single Rod End

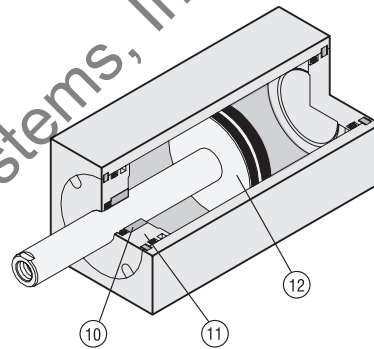

### Intermediate Duty

Single Rod End

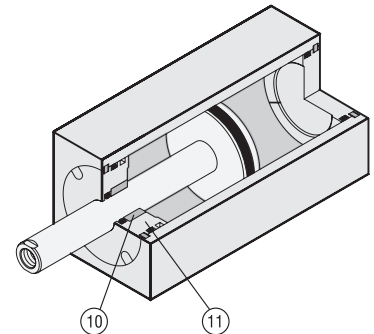

### Double Rod End

Standard or Heavy Duty

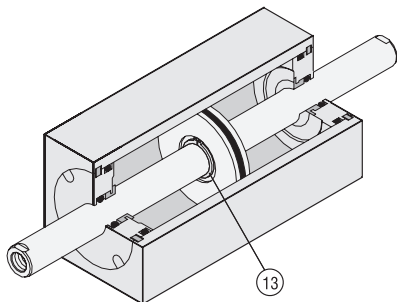

	Description	Material
1	End Cap	Aluminum
2	Retaining Wire	Stainless Steel
3	Rod Bearing	Sintered bronze
4	Cylinder Body	Aluminum
5	Piston Rod	Stainless steel
6	Piston Seal	Low friction Nitrile
7	End Cap Seal	O-ring (Nitrile)
8	Piston	Aluminum
9	Rod Seal	Low friction Nitrile
10	Husky Rod Bearing	Bronze
11	Husky End Cap	Aluminum
12	Husky Piston	Aluminum
13	Snap Ring	Carbon spring steel

Optional Magnetic Piston - Available on any cylinder, style or duty. (Not shown.)

Snap-Cap®, Magnetic Piston and Hydraulic option cylinder constructions may deviate from above listing - consult factory for additional information.



## Components and Material

### A.) Port Orifices

Enter directly into the bore; no turns, tapers or cross drilling. Crisp, powerful response to pneumatic pressure provides speed, control, and faster cycle time.

### B.) Factory Lubrication

Is standard on all cylinders and does not require air line induced lubrication, although additional air line lubrication may be used. Lubricated air that is compatible with petroleum based grease containing Teflon® is recommended. Non-lubricated air is recommended to operate the cylinder.

### C.) End Caps

Are machined of high grade aluminum alloy and anodized for protection against corrosion.

- 1/2" bore end caps feature our patented Snap-Cap® design - resilient retainer seal that aids in absorbing piston impact.
- 3/4" bore and larger feature our patented wire retainer design.

Optional urethane cushions may be added when additional impact resistance is required, available on 3/4" - 3" bore.

### D.) Retaining Wire

Is a patented stainless wire-form end cap retainer. This design provides more security than common fasteners and tie rods. It is easily removed for maintenance or seal replacement.

### E.) Rod Bearing

Varies according to duty and bore size.

- 1/2" Bore Snap-Cap  
All duties - Sintered bronze
- 3/4" through 5" Bore  
All duties - Sintered bronze
- 6" through 8" Bore  
All duties - Bearing bronze

### F.) Cylinder Body

Is a thick-walled, clear anodized, aluminum extrusion. Tight tolerances and concentricity guarantee longer life. Total Compact® envelope is up to 60% smaller than typical cylinders.

### G.) Seals

Are constructed of high grade, low friction, Nitrile materials. Optional seal materials, fluorocarbon and PTFE, are available – See Seal Descriptions in the Options section.

### H.) Piston Construction

- 1/2" Bore is a solid one piece construction on both the single and double rod end cylinders.
- 3/4" through 8" Bore
  - Single rod end cylinders - the lightweight aluminum piston is attached to the rod with a flat head socket screw. A thread adhesive is used to assure sealing and secure the assembly from shock and vibration damage.
  - Double rod end cylinders - the piston and rod feature a snap ring construction. Consult factory for alternative double piston shaft assembly construction.



# Modifications

## Unique Application Examples

For technical assistance and quotes contact your local distributor or our Technical Sales Department (864) 647-9521.

### Standard Product

- Square End Mount Cylinder
- Standard duty
- Standard port style and location
- Standard rod end



### Highly modified to meet the Customer's application requirements

- Modified Through Mount Cylinder
- Special duty including extended rod bearing and rod wiper
- Custom port style and location
- Special rod end with rod end attachment



## Modifications... simple solutions to space problems.

We have over 50,000 files of modified or special cylinder designs. Examples range from simple porting changes to 100% custom designed cylinders.

Our standard product design is a simple, plain extrusion, which allows us to easily modify our product to meet many unusual or unique requirements. Our design also allows modifications at a cost effective price and quick delivery.

In the Modified Products section we offer two Request for Quote fax forms to assist in a quick quote on your specifications via your local distributor.



### Simple Solutions

- Hollow piston rods
- Tunneled air ports
- Frame modifications
- Modified rod ends
- Multi-position cylinders
- Back-to-back cylinders
- Modified locations on: sensors, mounting and porting
- Multi-piston (multi force)



### Complex Solutions

- Extreme space limitations
- Multi-cylinder blocks
- Pneumatic industrial hand tools
- Load bearing cylinders





# 1/2" Bore Non Magnetic Piston

THIRD ANGLE PROJECTION



Duty	Part Number		Standard Stroke Length	A	B
	Single Rod	Double Rod			
Standard	<b>R12x</b> __	<b>RD12x</b> __	1/8 to 2 in 1/8" increments	.69	.22
Intermediate	<b>RHH12x</b> __		1/8 to 2 in 1/8" increments	.81	.34
Heavy	<b>RFH12x</b> __	<b>RFHD12x</b> __	1/8 to 2 in 1/8" increments	.94	.47

Standard Mounting: **TF**    Optional Mounting: **TR, TBE, TMF, TMR**

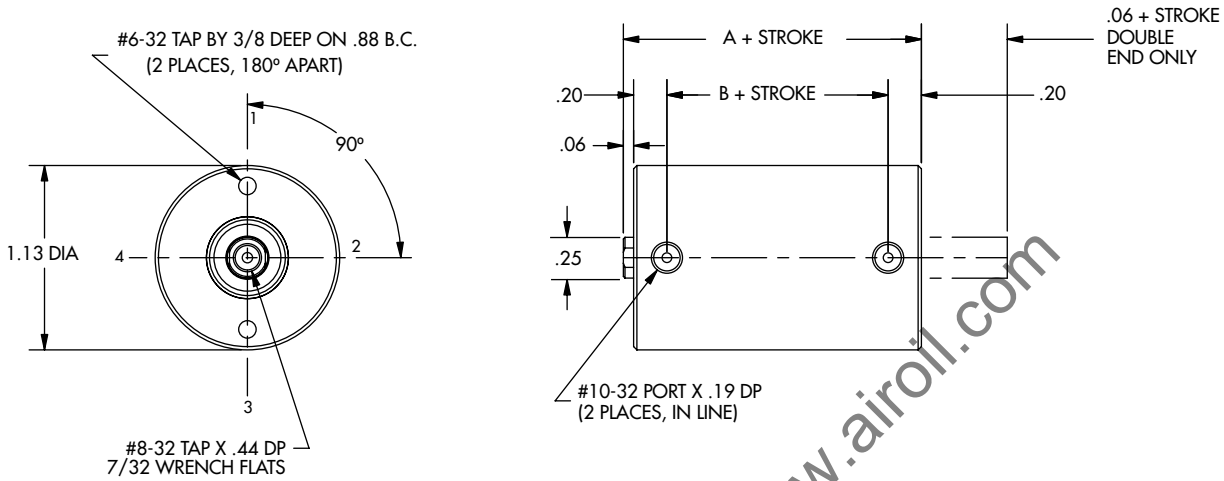

# 1/2" Bore Magnetic Piston

Duty	Part Number		Standard Stroke Length	A
	Single Rod	Double Rod		
Standard	<b>AR12x</b> __	<b>ARD12x</b> __	1/8 to 2 in 1/8" increments	.94
Intermediate	<b>ARHH12x</b> __		1/8 to 2 in 1/8" increments	1.06
Heavy	<b>ARFH12x</b> __	<b>ARFHD12x</b> __	1/8 to 2 in 1/8" increments	1.19

Standard Mounting: **TF**    Optional Mounting: **TR, TBE, TMF, TMR**

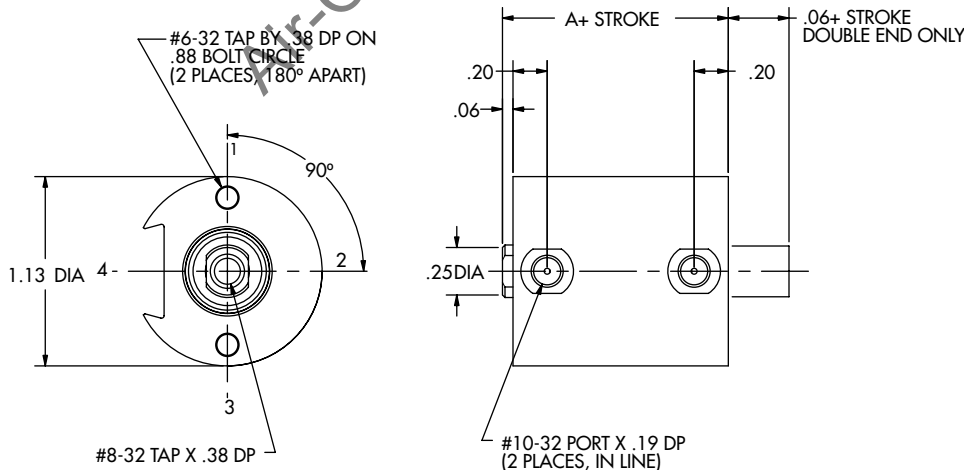

Due to physical size, body lengths 1-1/2" and shorter have only one sensor; Body length = A + stroke - .06. For modifications, consult factory.

Style "S"

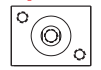

End Mount

# 1/2" Bore Non Magnetic Piston Snap-Cap® Design

Duty	Part Number		Standard Stroke Length	A
	Single Rod	Double Rod		
Standard	<b>S12x</b> __	<b>SD12x</b> __	1/8 to 2 in 1/8" increments	.69
Intermediate	<b>SHH12x</b> __		1/8 to 2 in 1/8" increments	.81
Heavy	<b>SFH12x</b> __	<b>SFHD12x</b> __	1/8 to 2 in 1/8" increments	.94

THIRD ANGLE PROJECTION

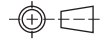

Standard Mounting: **TF**    Optional Mounting: **TR, TBE, TM**

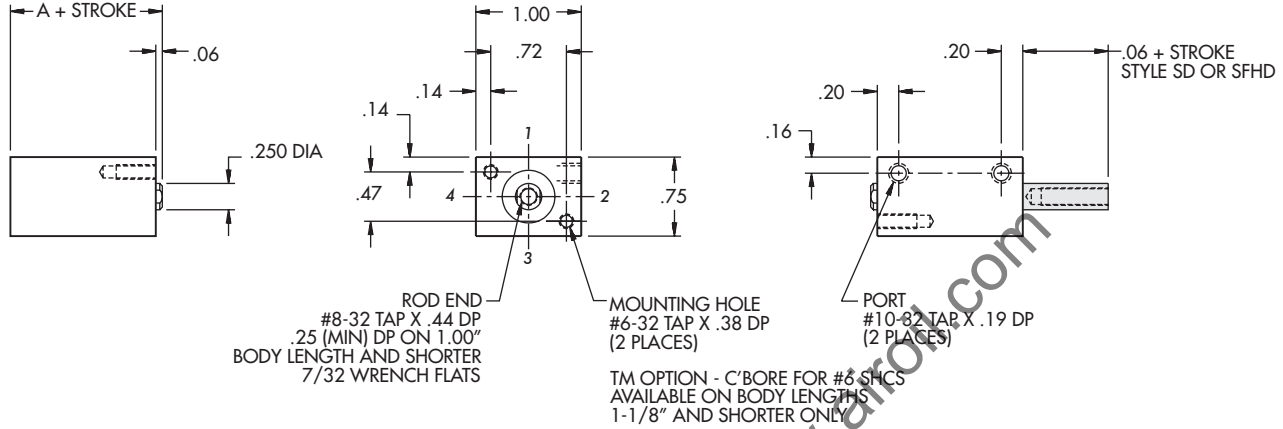

Style "AS"

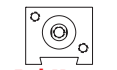

End Mount

# 1/2" Bore Magnetic Piston Snap-Cap® Design

Duty	Part Number		Standard Stroke Length	A
	Single Rod	Double Rod		
Standard	<b>AS12x</b> __	<b>ASD12x</b> __	1/8 to 2 in 1/8" increments	.94
Intermediate	<b>ASHH12x</b> __		1/8 to 2 in 1/8" increments	1.06
Heavy	<b>ASFH12x</b> __	<b>ASFHD12x</b> __	1/8 to 2 in 1/8" increments	1.19

Standard Mounting: **TF**    Optional Mounting: **TR, TBE, TM**

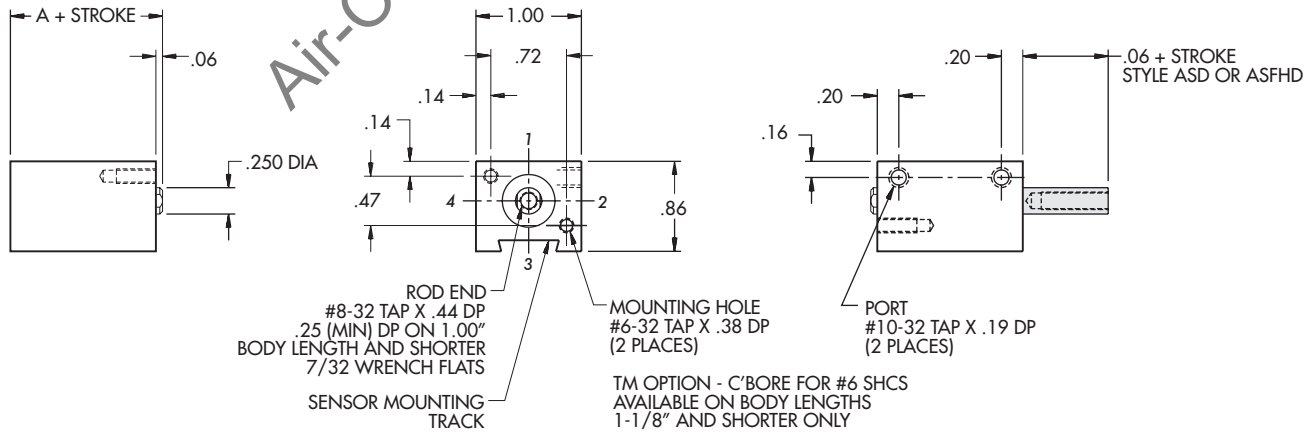

Due to physical size, body lengths 1-1/2" and shorter have only one sensor; Body length = A + stroke - .06. For modifications, consult factory.

# 1/2" Bore Non Magnetic Piston Snap-Cap® Design

Style "T"

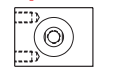

Side Mount

THIRD ANGLE PROJECTION

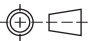

Duty	Part Number		Standard Stroke Length	A
	Single Rod	Double Rod		
Standard	T12x__	TD12x__	1/8 to 2 in 1/8" increments	.69
Intermediate	THH12x__		1/8 to 2 in 1/8" increments	.81
Heavy	TFH12x__	TFHD12x__	1/8 to 2 in 1/8" increments	.94

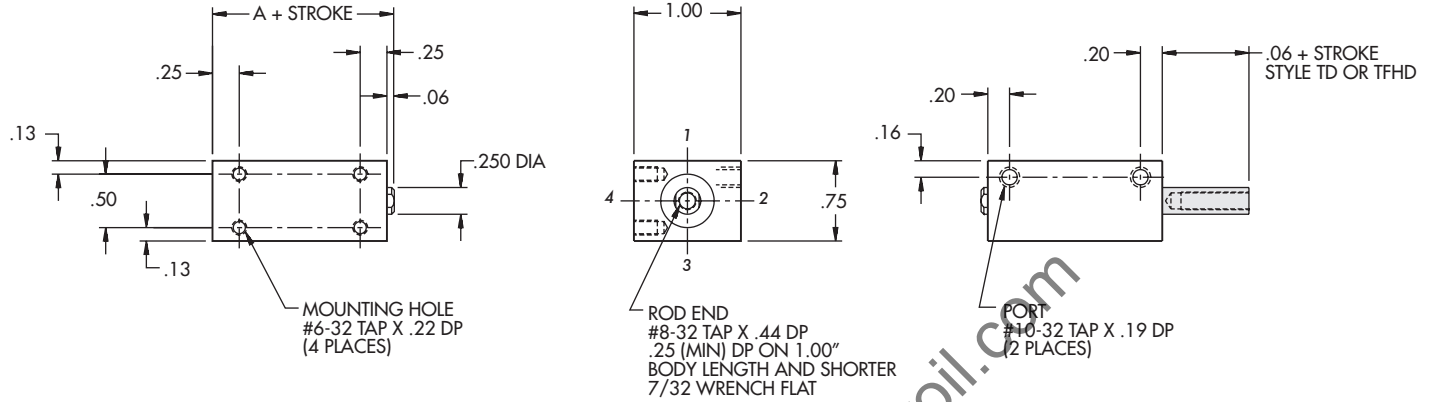

# 1/2" Bore Magnetic Piston Snap-Cap® Design

Style "AT"

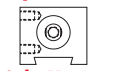

Side Mount

Duty	Part Number		Standard Stroke Length	A
	Single Rod	Double Rod		
Standard	AT12x__	ATD12x__	1/8 to 2 in 1/8" increments	.94
Intermediate	ATHH12x__		1/8 to 2 in 1/8" increments	1.06
Heavy	ATFH12x__	ATFHD12x__	1/8 to 2 in 1/8" increments	1.19

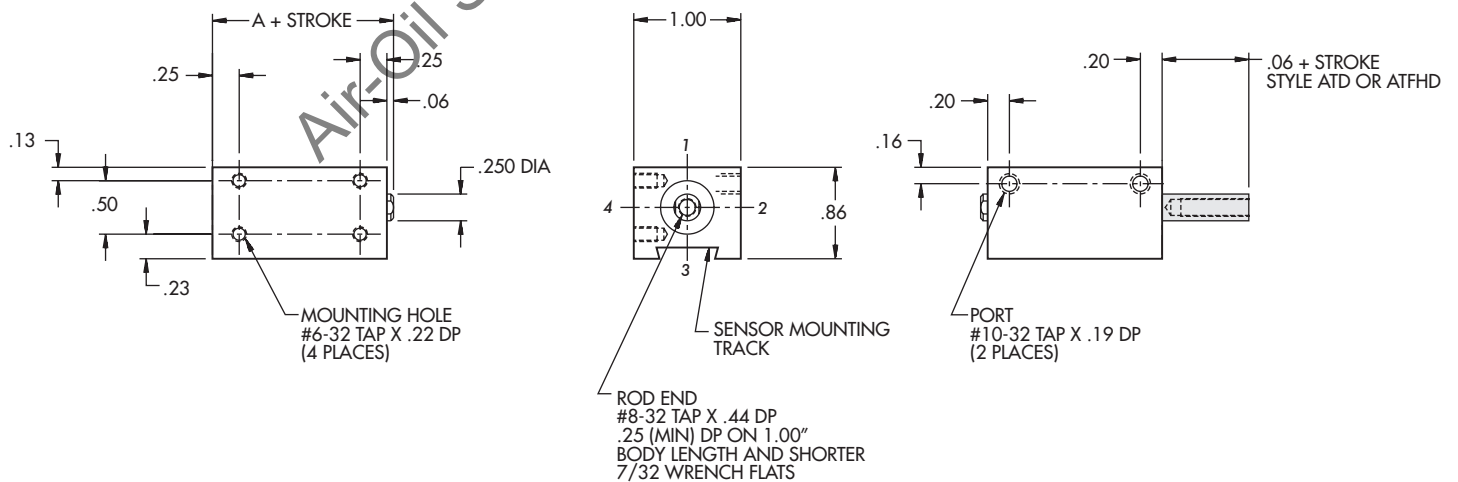

Due to physical size, body lengths 1-1/2" and shorter have only one sensor; Body length = A + stroke - .06. For modifications, consult factory.



# 1/2" Bore Non Magnetic Piston Snap-Cap® Design

THIRD ANGLE PROJECTION

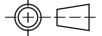

Duty	Part Number		Standard Stroke Length	A
	Single Rod	Double Rod		
Standard	<b>B12x</b> __	<b>BD12x</b> __	1/8, 1/4	.69
Intermediate	<b>BHH12x</b> __		1/8	.81

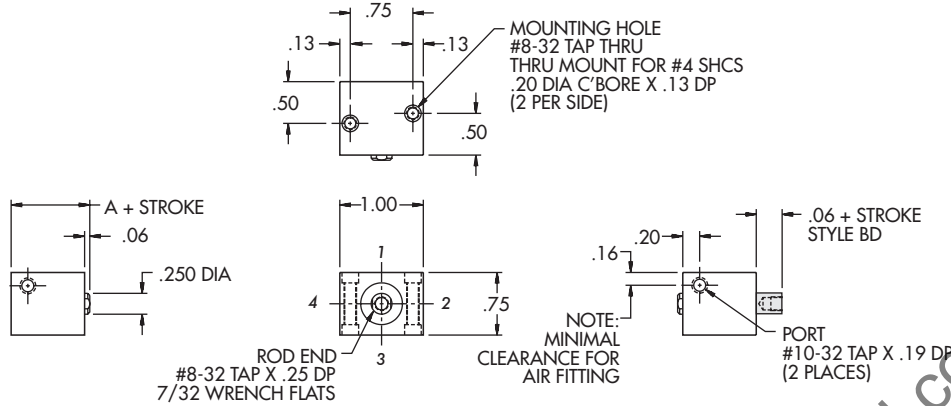

Duty	Part Number		Standard Stroke Length	A
	Single Rod	Double Rod		
Standard	<b>B12x</b> __	<b>BD12x</b> __	3/8 to 1-1/4 in 1/8" increments	.69
Intermediate	<b>BHH12x</b> __		1/4 to 1-1/8 in 1/8" increments	.81
Heavy	<b>BFH12x</b> __	<b>BFHD12x</b> __	1/8 to 1 in 1/8" increments	.94

Information same as above except where noted.

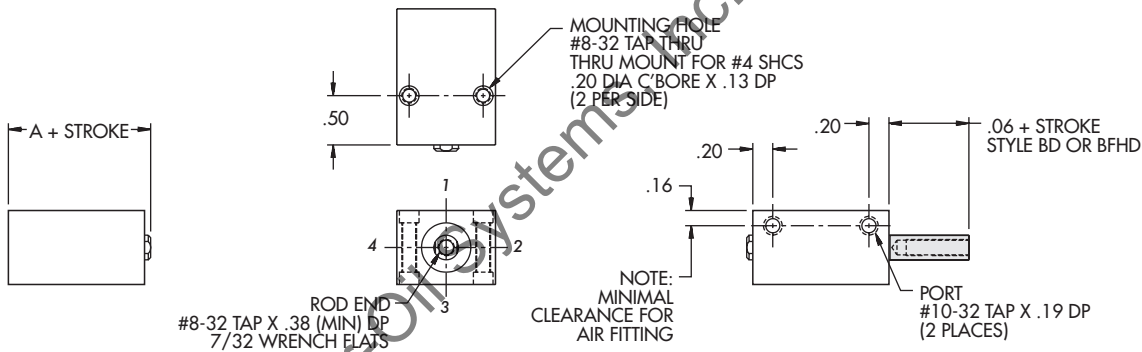

Duty	Part Number		Standard Stroke Length	A
	Single Rod	Double Rod		
Standard	<b>B12x</b> __	<b>BD12x</b> __	1-3/8 to 2 in 1/8" increments	.69
Intermediate	<b>BHH12x</b> __		1-1/4 to 2 in 1/8" increments	.81
Heavy	<b>BFH12x</b> __	<b>BFHD12x</b> __	1-1/8 to 2 in 1/8" increments	.94

Information same as above except where noted.

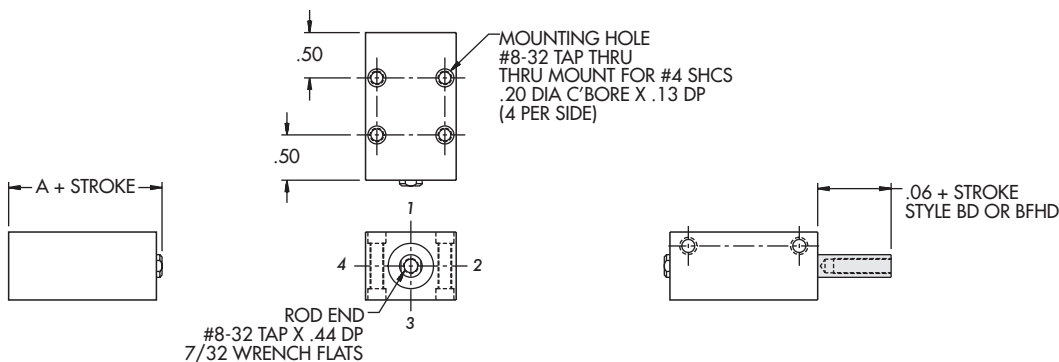





# 1/2" Bore Magnetic Piston Snap-Cap® Design

THIRD ANGLE PROJECTION



Duty	Part Number		Standard Stroke Length	A
	Single Rod	Double Rod		
Standard	AB12x__	ABD12x__	1/8 to 1 in 1/8" increments	.94
Intermediate	ABHH12x__		1/8 to 7/8 in 1/8" increments	1.06
Heavy	ABFH12x__	ABFHD12x__	1/8 to 3/4 in 1/8" increments	1.19

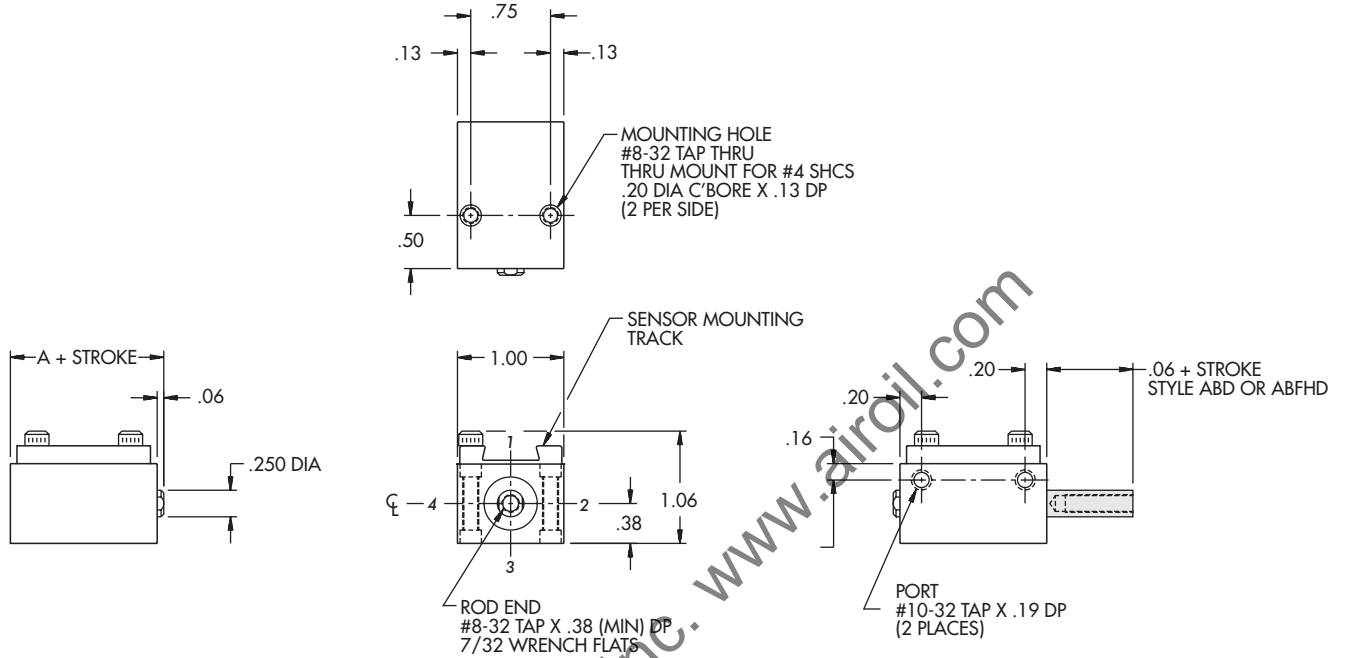

Duty	Part Number		Standard Stroke Length	A
	Single Rod	Double Rod		
Standard	AB12x__	ABD12x__	1-1/8 to 2 in 1/8" increments	.94
Intermediate	ABHH12x__		1 to 2 in 1/8" increments	1.06
Heavy	ABFH12x__	ABFHD12x__	7/8 to 2 in 1/8" increments	1.19

Information same as above except where noted.

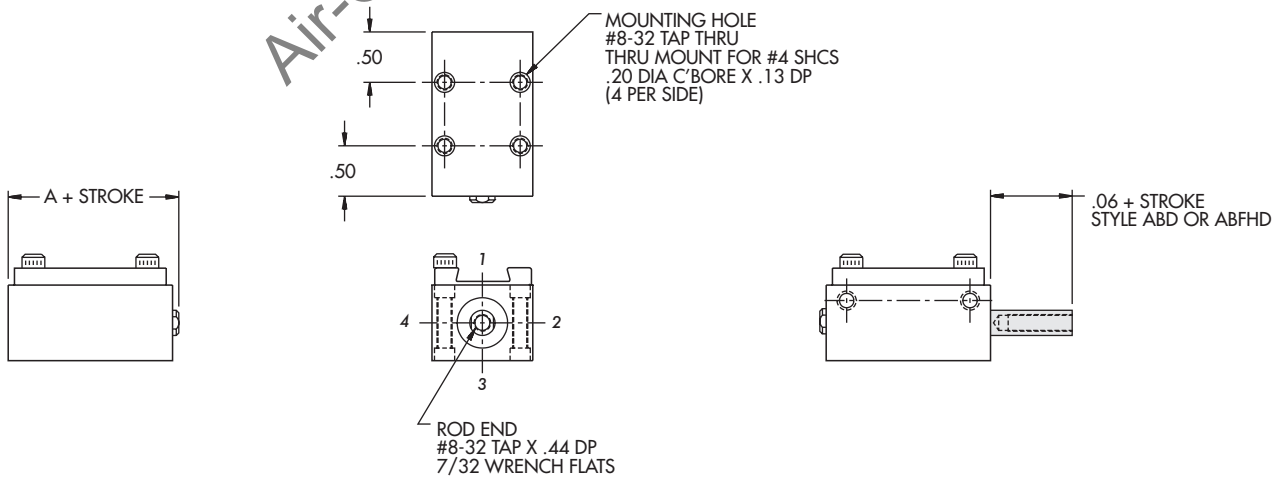

Due to physical size, body lengths 1-1/2" and shorter have only one sensor; Body length = A + stroke - .06. For modifications, consult factory.

# 1/2" Bore Options

Conversion Formula:  $C^{\circ} = (F^{\circ} - 32^{\circ}) \times .56$

Type	Ordering Suffix	Rating	Description
<b>Pneumatic Seals</b>			
Nitrile	-	0° to 200°F -18° to 93°C	Most commonly used elastomer O-ring due to its excellent resistance to petroleum products, wear, tear and friction. Works with lubricated or non-lubricated air in the noted temperature range. Recommended for general purpose sealing with petroleum oils and fluids, water and silicone greases and oils.
Fluorocarbon	<b>HTV</b>	0° to 400°F -18° to 204°C	Used mainly for elevated temperatures, harsh environments where some coolants, solvents, cleaning agents or other chemicals will contact the seal gland. Lower compression set is characteristic. For your specific requirements, consult factory.

# 1/2" Bore Round Body Cylinder Options

**TR Mounting – Threads on Rear**  
(Optional; specify TR after bore and stroke.)

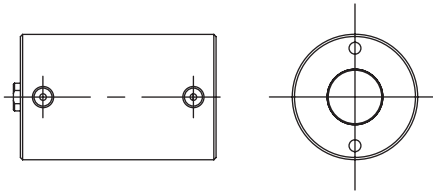

**TBE Mounting – Threads on Both Ends**  
(Optional; specify TBE after bore and stroke.)

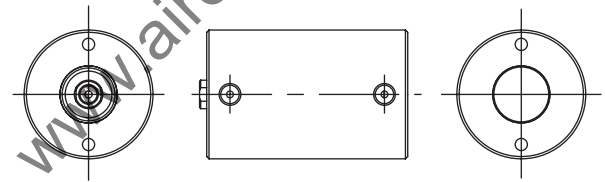

**TMF Mounting – Thru-Mount (Front)**  
(Optional; specify TMF after bore and stroke.)  
C'bored for #6 SHCS on shaft end only.  
Available only on 1-1/8" body lengths and shorter.

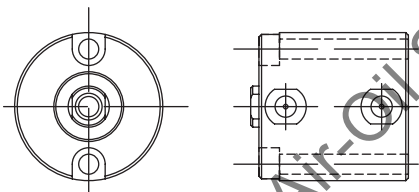

**TMR Mounting – Thru-Mount (Rear)**  
(Optional; specify TMR after bore and stroke.)  
C'bored for #6 SHCS on rear end only.  
Available only on 1-1/8" body lengths and shorter.

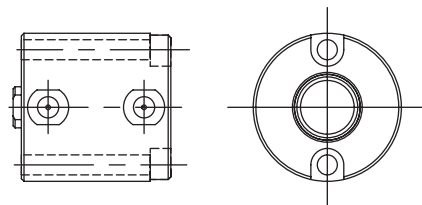

## Threaded Nose Mount

**Threaded Nose Mounting for  
"R" Series Cylinder Option NM**

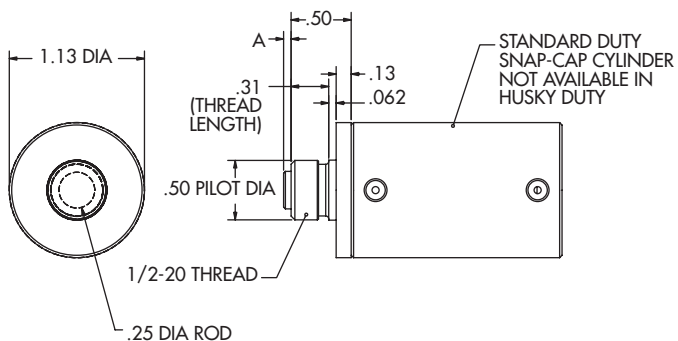

A= 1/16 on all Stroke Cylinders except:  
A= 3/16 on 1-5/8" and 1-7/8" Stroke Standard Duty Cylinders  
A= 3/16 on 1-3/8" and 1-5/8" Stroke Magnetic Standard Duty Cylinders

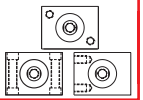

# 1/2" Bore Options

THIRD ANGLE PROJECTION

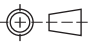

## Corrosion Resistant 300 Series Stainless Steel

### Standard Duty Features:

- 100% 300 series stainless steel components – interior and exterior
- Plastic rod bearings

### Intermediate and Heavy Duty Features:

- 100% 300 series stainless steel components – interior and exterior
- Plastic rod bearings

### Magnetic Piston Cylinders:

- Bolt-on Mounting Track is aluminum only

**Ordering:** Specify "CR3" before cylinder part number

**Delivery:** Non-standard delivery, consult factory

**CR3**

**Ordering Prefix:** CR3

**Material:** 300 Series stainless steel

### Applications:

- Chemical / Petroleum
- Medical Equipment
- Salt Water Exposure
- Clean Rooms
- Food Processing
- Electronic Assembly
- Nuclear
- Pharmaceutical



## Adjustable Retract Stroke

**DO NOT** use with any pivoting applications

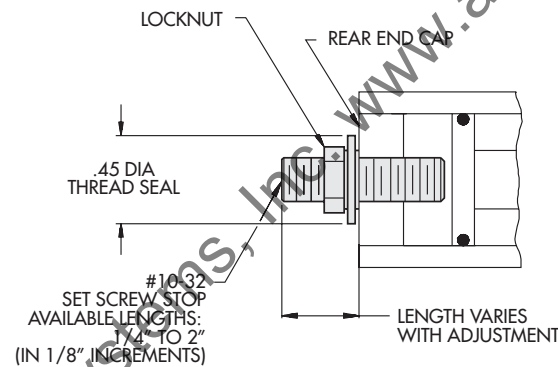

**ADJ\_**

Specify Length

**Ordering Suffix:** ADJ\_

**Length:** 1/4 - 2 in 1/8" increments

**Rod:** Single only

**Temperature:** 200°F Max.

**Material:** Aluminum endcap, steel locknut and thread seal

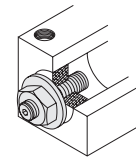

## Positive Alignment Available on "S" and "R" style cylinders only

The alignment pocket and pilot are designed to fit between the cylinder and the mounting surface. This ensures accurate mounting and added shear strength.

### Alignment Pocket

- Provides positive means of locating cylinder centerline within .005"

**PA**

**Ordering Suffix:** PA  
**Style:** "S" and "R"  
**Rod:** Single

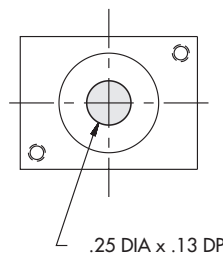

### Alignment Pilot

Sold separately

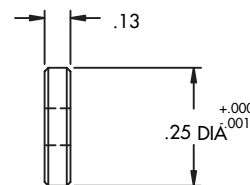

**PL12**

**Part Number:** PL12  
**Material:** Stainless steel

All dimensions are in inches unless otherwise noted.

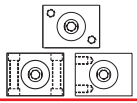

# 1/2" Bore Options

## Hollow Rod Option

Our hollow rod option is available for applications that require passage through a double ended rod.

- Available on 1/4 - 2" stroke in 1/8" increments.

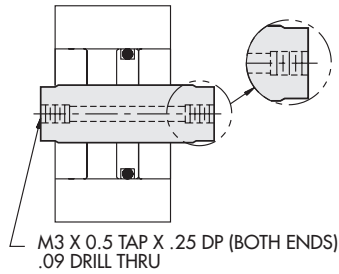

### HR3

**Ordering Suffix:** HR3  
**Rod:** Double only

Applications		
Example	YES	NO
Gases	✓	
Liquids	✓	
Vacuum	✓	
Linear / Rotary Cylinder	✓	
Clamp and Punch Cylinder	✓	
Blow Molding Cylinder	✓	
Hydraulic Cylinders		X
Non-Rotating Rods		X

## Male Stud

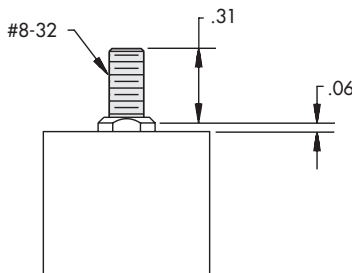

Double ended unit has stud in front end only.

If male stud is desired on *both* ends, specify **MSD**.

Male stud thread: Same pitch and diameter as female rod tap

### MS516

**Ordering Suffix:** MS516  
**Material:** Steel black oxide

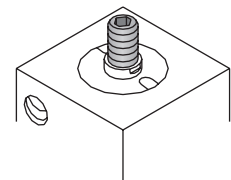

## Clevis Bracket with Set Screw

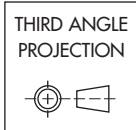
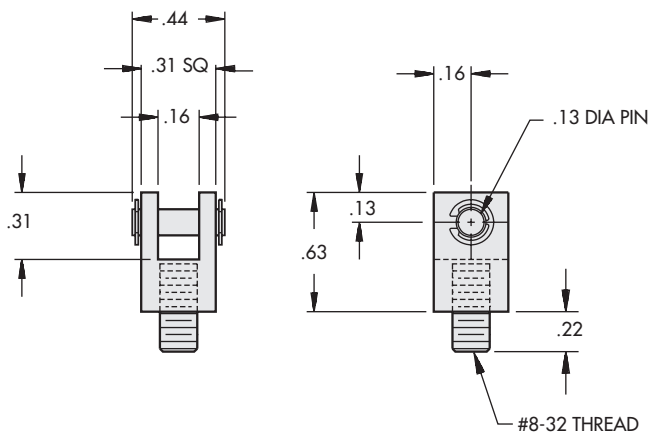

### CBSS12

**Ordering Suffix:** CBSS12  
**Material:** Steel black oxide with case hardened pin and clips



All dimensions are in inches unless otherwise noted.

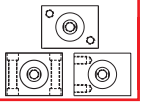

# 1/2 Bore Options

THIRD ANGLE PROJECTION



## Rod End Extension

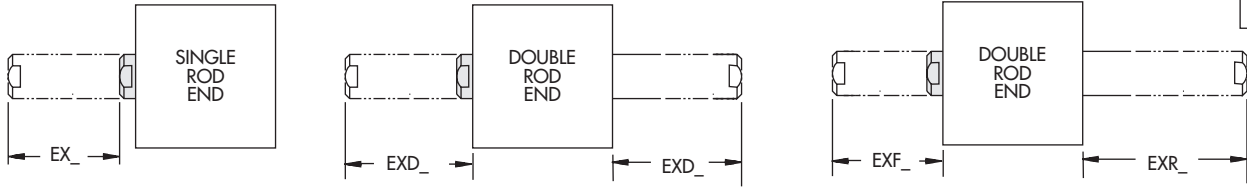

Extended equally at both ends

- For special extension or length - consult factory
- Not a screw on component
- Female tap does not change

Single Rod End

Double Rod End

**EX\_**

**EXD\_**

Specify Length

Specify Length

Extension Front End

Extension Rear End

**EXF\_**

**EXR\_**

Specify Length

Specify Length

**Ordering Suffix:** EX\_, EXD\_, EXF\_ or EXR\_

**Length:** 1/8 - 1 in 1/8" increments

## Rod Eye

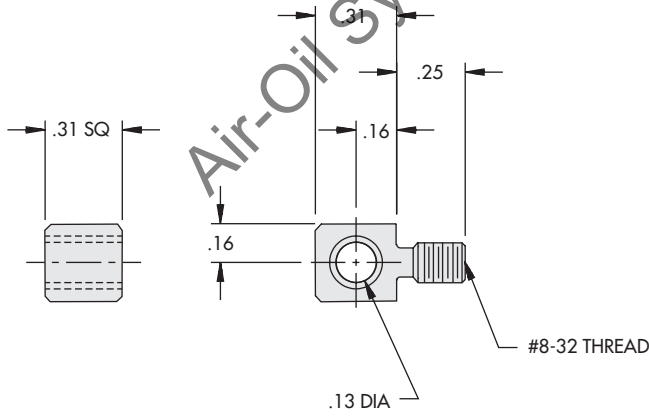

Screws flush with cylinder rod face

**RE**

**Ordering Suffix:** RE  
**Material:** Steel black oxide with sintered bronze bearing

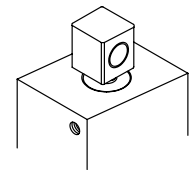

All dimensions are in inches unless otherwise noted.



# 1/2" Bore Options

## Short Rear Clevis with Eye Mount

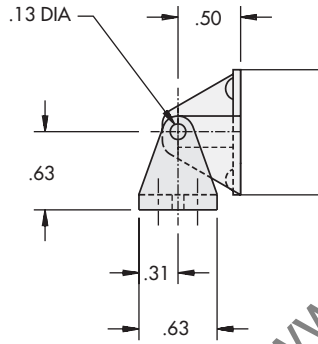
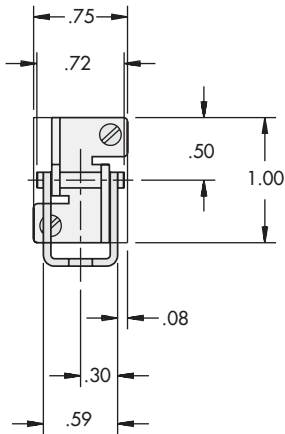
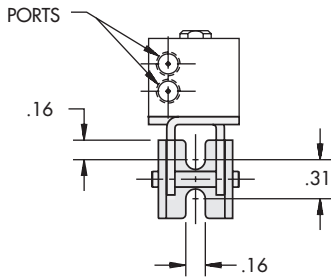

THIRD ANGLE PROJECTION

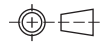

### SRCE

- Ordering Suffix:** SRCE
- Style:** "S" only
- Rod:** Single only
- Pivot:** 180°
- Material:** Short Rear Clevis:  
See Below  
Eye Mount:  
Steel black oxide

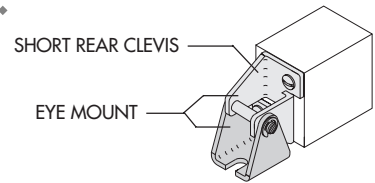

Cylinder is reverse assembled with magnetic piston option.

## Short Rear Clevis

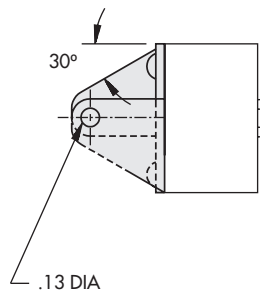
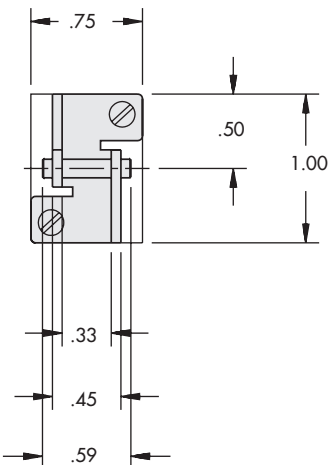
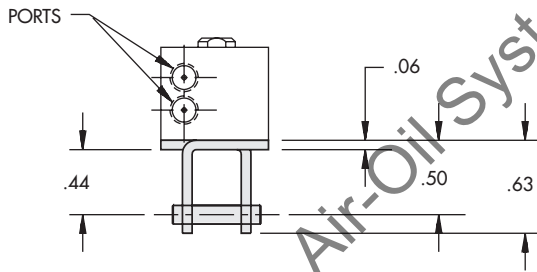

### SRC

- Ordering Suffix:** SRC
- Style:** "S" only
- Rod:** Single only
- Material:** Short Rear Clevis:  
Steel black oxide  
with case hardened  
pin and clips

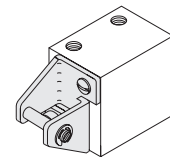

Cylinder is reverse assembled with magnetic piston option.

All dimensions are in inches unless otherwise noted.



# 1/2" Bore Options



## Flange Mount (shown as Rear Flange)

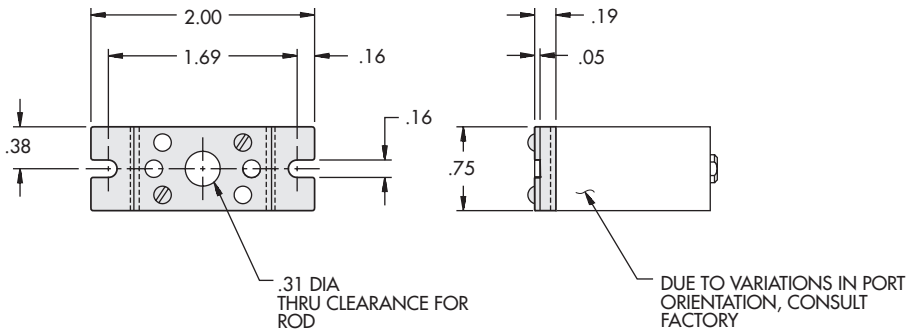

Front Flange

**FF**

Rear Flange

**RF**

**Ordering Suffix:** FF or RF  
**Style:** "S" and "R"  
**Material:** Steel black oxide

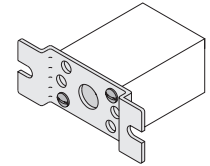

## End Bracket

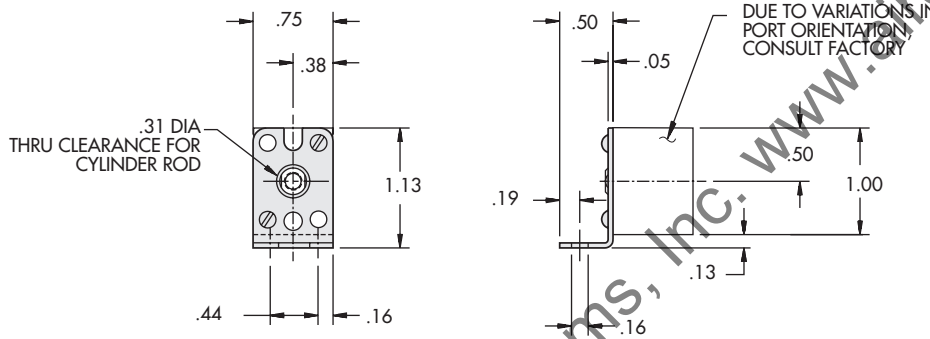

**EB**

**Ordering Suffix:** EB  
**Style:** "S" only  
**Material:** Steel black oxide

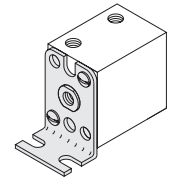

### Number of brackets required:

- 1-1/2" body length and shorter = 1 bracket
- Over 1-1/2" body length = 2 brackets  
(must specify suffix: TBE mounting, threads both ends)

## Side Bracket

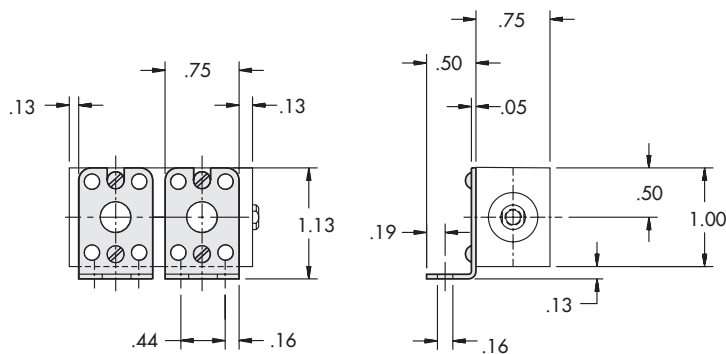

**SB**

**Ordering Suffix:** SB  
**Style:** "B" only  
**Body Length:** 1" and larger  
**Material:** Steel black oxide

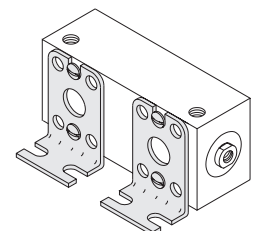

### Number of brackets required:

- Two mounting holes = 1 bracket
- Four mounting holes = 2 brackets

### Application Idea

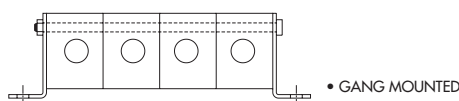

All dimensions are in inches unless otherwise noted.



# 3/4" Bore Non Magnetic Piston

THIRD ANGLE PROJECTION

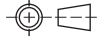

Duty	Part Number		Standard Stroke Length	A
	Single Rod	Double Rod		
Standard	<b>S34x</b> ___	<b>SD34x</b> ___	1/8 to 3/4 in 1/8" increments	.81
Intermediate	<b>SHH34x</b> ___		1/8 to 1/2 in 1/8" increments	1.06
Heavy	<b>SFH34x</b> ___	<b>SFHD34x</b> ___	1/8, 1/4	1.31

Standard Mounting: **TF, TR, TBE, TM**    Optional Porting: **1/8-27 NPTF**

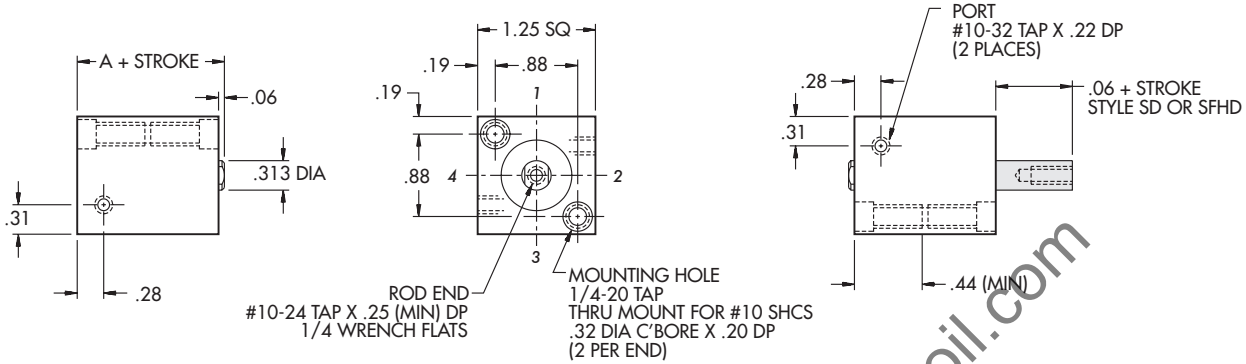

Duty	Part Number		Standard Stroke Length	A
	Single Rod	Double Rod		
Standard	<b>S34x</b> ___	<b>SD34x</b> ___	7/8, 1	.81
Intermediate	<b>SHH34x</b> ___		5/8, 3/4	1.06
Heavy	<b>SFH34x</b> ___	<b>SFHD34x</b> ___	3/8, 1/2	1.31

Standard Mounting: **TF, TR, TBE, TM**    Optional Porting: **1/8-27 NPTF**

Information same as above except where noted.

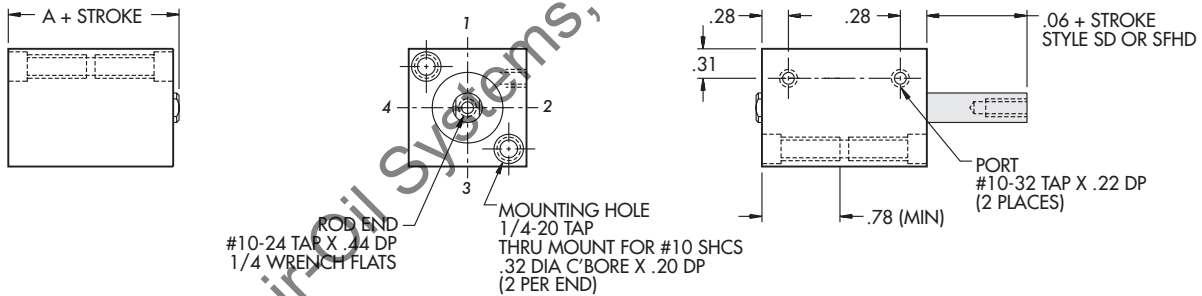

Duty	Part Number		Standard Stroke Length	A
	Single Rod	Double Rod		
Standard	<b>S34x</b> ___	<b>SD34x</b> ___	1-1/8 to 6 in 1/8" increments	.81
Intermediate	<b>SHH34x</b> ___		7/8 to 6 in 1/8" increments	1.06
Heavy	<b>SFH34x</b> ___	<b>SFHD34x</b> ___	5/8 to 6 in 1/8" increments	1.31

Standard Mounting: **TF**    Optional Mounting: **TR, TBE, TM**    Optional Porting: **1/8-27 NPTF**

Information same as above except where noted.

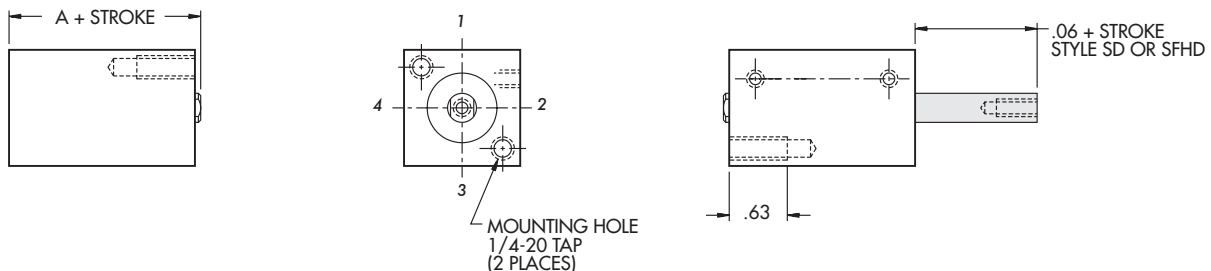



# 3/4" Bore Magnetic Piston

THIRD ANGLE PROJECTION

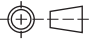

Duty	Part Number		Standard Stroke Length	A
	Single Rod	Double Rod		
Standard	<b>AS34x</b> __	<b>ASD34x</b> __	1/8 to 1/2 in 1/8" increments	1.06
Intermediate	<b>ASHH34x</b> __		1/8, 1/4	1.31

Standard Mounting: **TF, TR, TBE, TM**    Optional Porting: **1/8-27 NPTF**

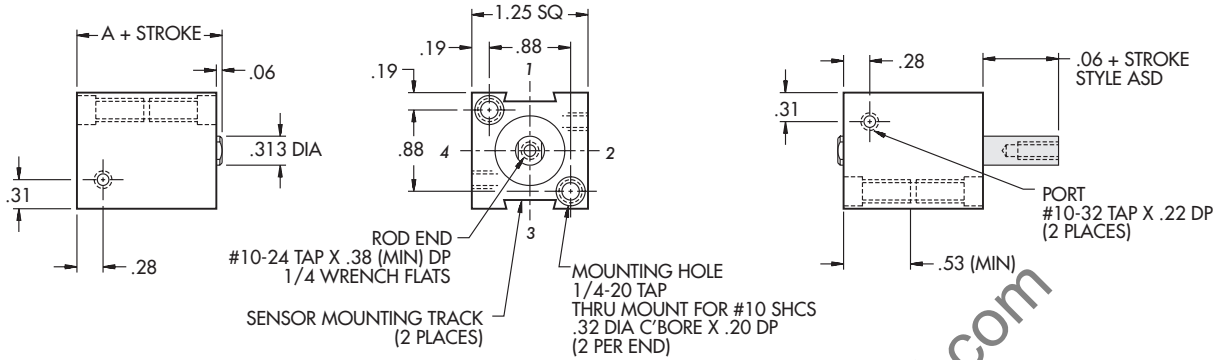

Duty	Part Number		Standard Stroke Length	A
	Single Rod	Double Rod		
Standard	<b>AS34x</b> __	<b>ASD34x</b> __	5/8 to 3/4 in 1/8" increments	1.06
Intermediate	<b>ASHH34x</b> __		3/8 to 1/2 in 1/8" increments	1.31
Heavy	<b>ASFH34x</b> __	<b>ASFHD34x</b> __	1/8 to 1/4 in 1/8" increments	1.56

Standard Mounting: **TF, TR, TBE, TM**    Optional Porting: **1/8-27 NPTF**

Information same as above except where noted.

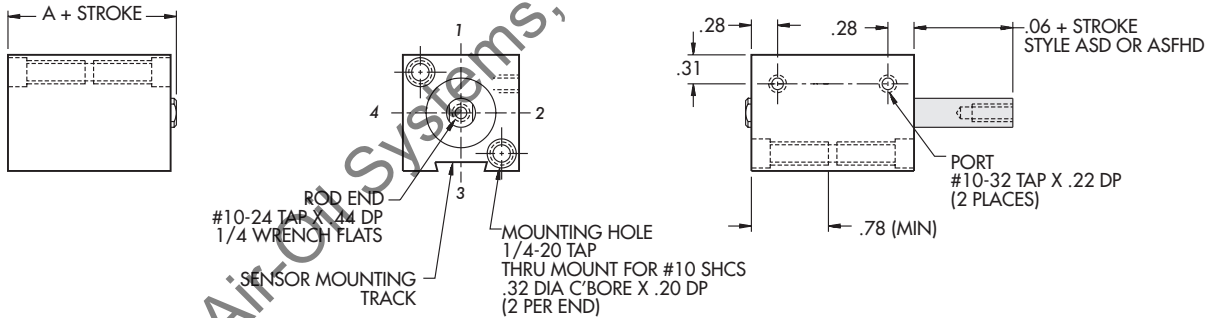

Duty	Part Number		Standard Stroke Length	A
	Single Rod	Double Rod		
Standard	<b>AS34x</b> __	<b>ASD34x</b> __	7/8 to 6 in 1/8" increments	1.06
Intermediate	<b>ASHH34x</b> __		5/8 to 6 in 1/8" increments	1.31
Heavy	<b>ASFH34x</b> __	<b>ASFHD34x</b> __	3/8 to 6 in 1/8" increments	1.56

Standard Mounting: **TF**    Optional Mounting: **TR, TBE, TM**    Optional Porting: **1/8-27 NPTF**

Information same as above except where noted.

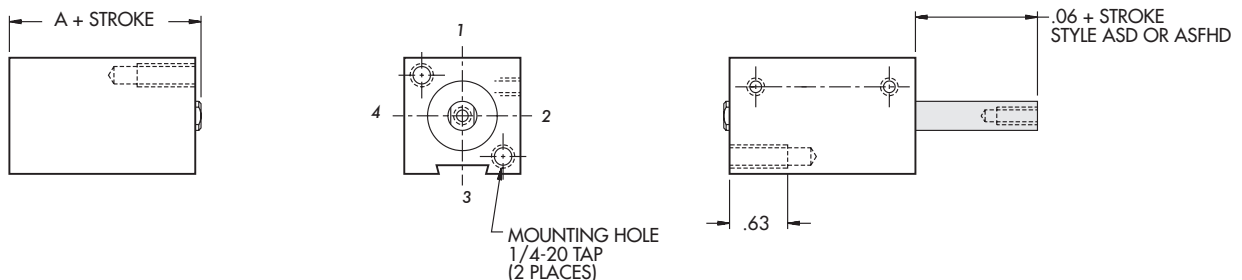

Style "B"



Side Mount

# 3/4" Bore Non Magnetic Piston

Duty	Part Number		Standard Stroke Length	A
	Single Rod	Double Rod		
Standard	<b>B34x</b> __	<b>BD34x</b> __	1/8 to 3/4 in 1/8" increments	.81
Intermediate	<b>BHH34x</b> __		1/8 to 1/2 in 1/8" increments	1.06
Heavy	<b>BFH34x</b> __	<b>BFHD34x</b> __	1/8, 1/4	1.31

THIRD ANGLE PROJECTION

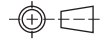

Optional Porting: **1/8-27 NPTF**

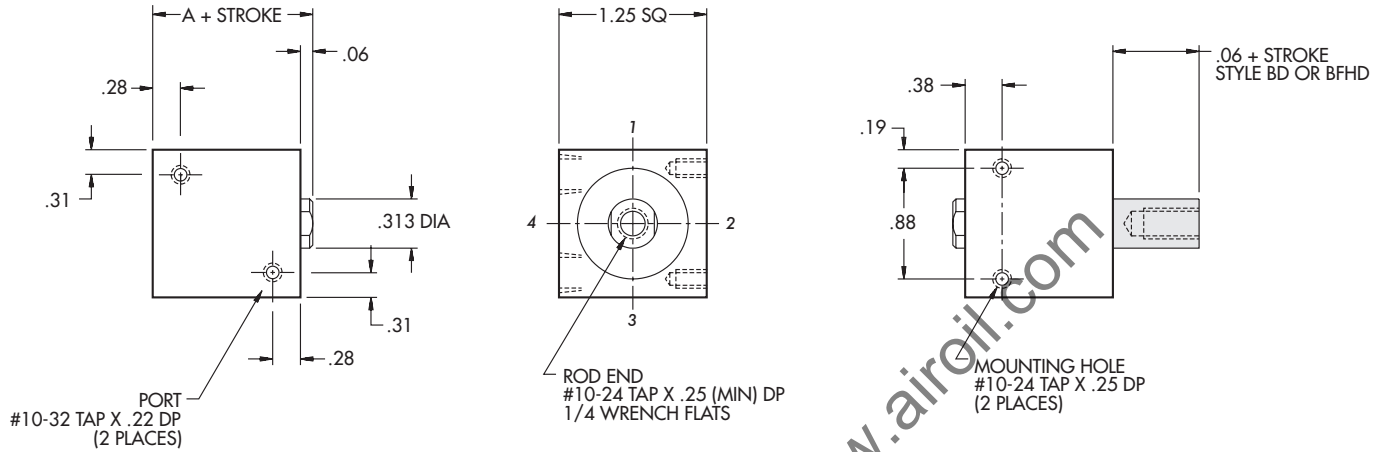

Duty	Part Number		Standard Stroke Length	A
	Single Rod	Double Rod		
Standard	<b>B34x</b> __	<b>BD34x</b> __	7/8 to 6 in 1/8" increments	.81
Intermediate	<b>BHH34x</b> __		5/8 to 5 in 1/8" increments	1.06
Heavy	<b>BFH34x</b> __	<b>BFHD34x</b> __	3/8 to 6 in 1/8" increments	1.31

Optional Porting: **1/8-27 NPTF**

Information same as above except where noted.

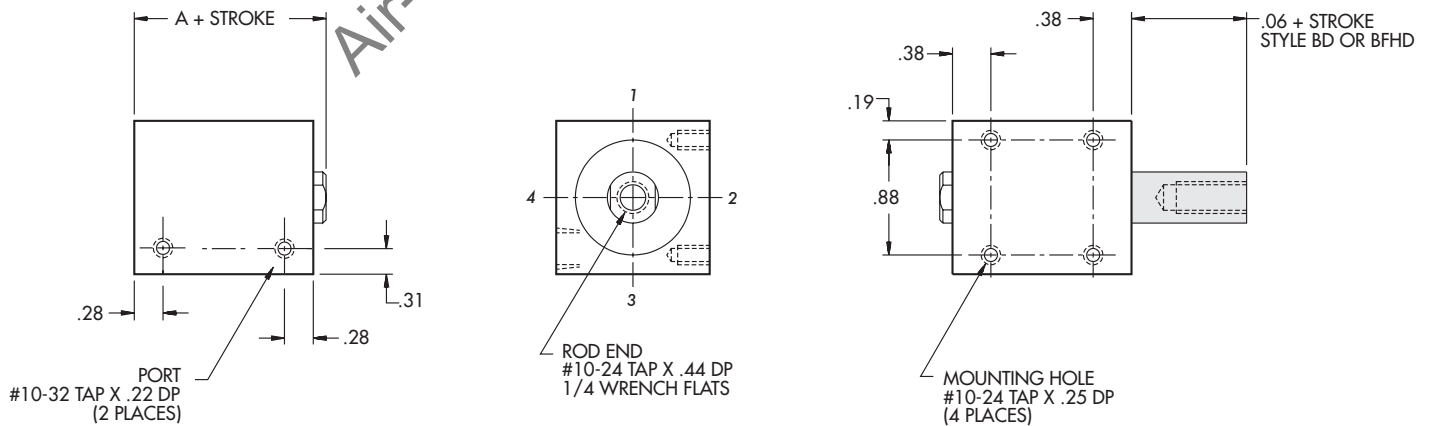

# 3/4" Bore Magnetic Piston

Style "AB"



Side Mount

THIRD ANGLE PROJECTION



Duty	Part Number		Standard Stroke Length	A
	Single Rod	Double Rod		
Standard	AB34x__	ABD34x__	1/8 to 1/2 in 1/8" increments	1.06
Intermediate	ABHH34x__		1/8, 1/4	1.31

Optional Porting: **1/8-27 NPTF**

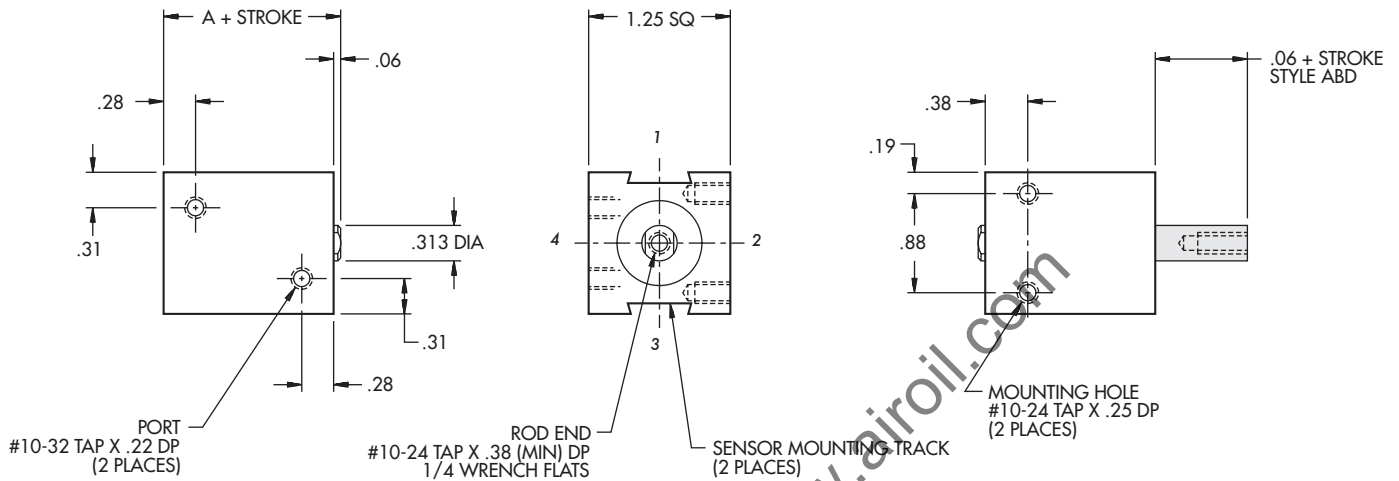

Duty	Part Number		Standard Stroke Length	A
	Single Rod	Double Rod		
Standard	AB34x__	ABD34x__	5/8 to 6 in 1/8" increments	1.06
Intermediate	ABHH34x__		3/8 to 6 in 1/8" increments	1.31
Heavy	ABFH34x__	ABFHD34x__	1/8 to 6 in 1/8" increments	1.56

Optional Porting: **1/8-27 NPTF**

Information same as above except where noted.

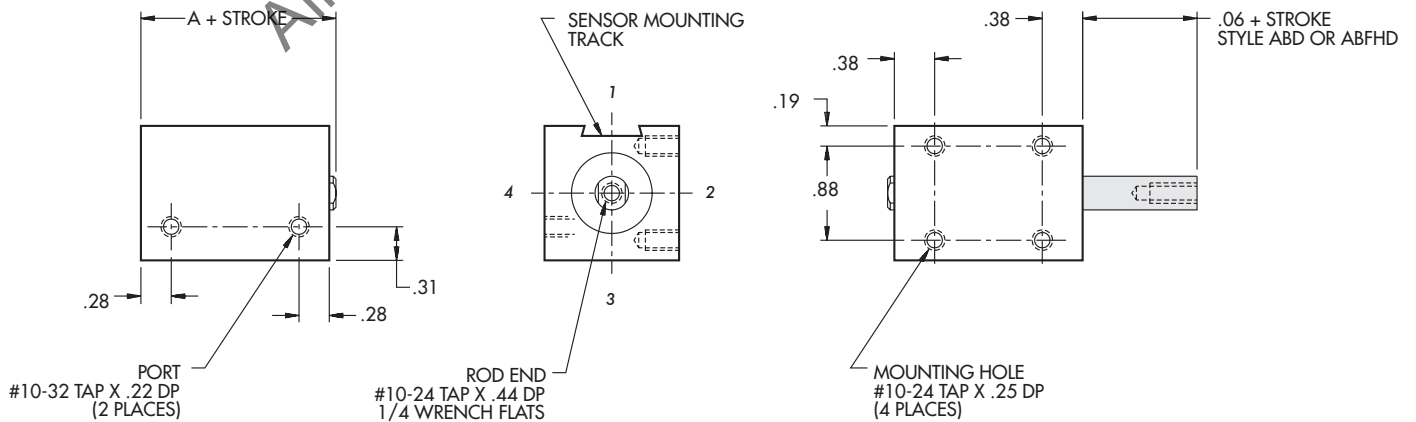

Style "R"



End Mount

# 3/4" Bore Non Magnetic Piston

Duty	Part Number		Standard Stroke Length	A
	Single Rod	Double Rod		
Standard	<b>R34x</b> __	<b>RD34x</b> __	1/8 to 3/4 in 1/8" increments	.81
Intermediate	<b>RHH34x</b> __		1/8 to 1/2 in 1/8" increments	1.06
Heavy	<b>RFH34x</b> __	<b>RFHD34x</b> __	1/8, 1/4	1.31

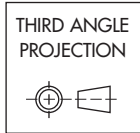

Standard Mounting: **TF, TR, TBE**    Optional Mounting: **TM**    Optional Porting: **1/8-27 NPTF**

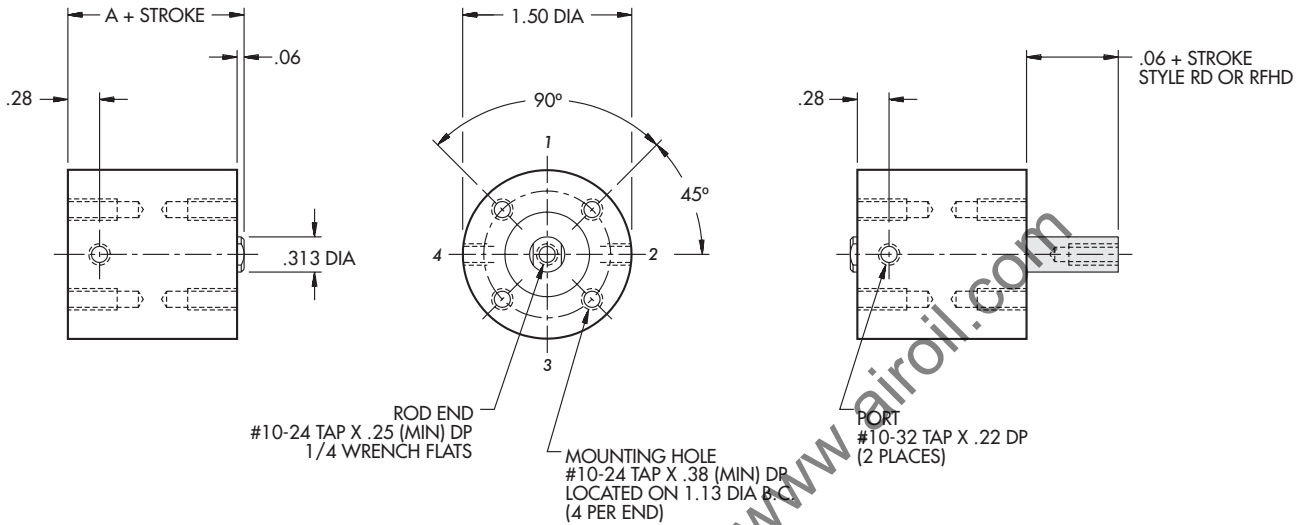

Duty	Part Number		Standard Stroke Length	A
	Single Rod	Double Rod		
Standard	<b>R34x</b> __	<b>RD34x</b> __	7/8 to 6 in 1/8" increments	.81
Intermediate	<b>RHH34x</b> __		5/8 to 6 in 1/8" increments	1.06
Heavy	<b>RFH34x</b> __	<b>RFHD34x</b> __	3/8 to 6 in 1/8" increments	1.31

Standard Mounting: **TF**    Optional Mounting: **TR, TBE, TM**    Optional Porting: **1/8-27 NPTF**  
 Information same as above except where noted.

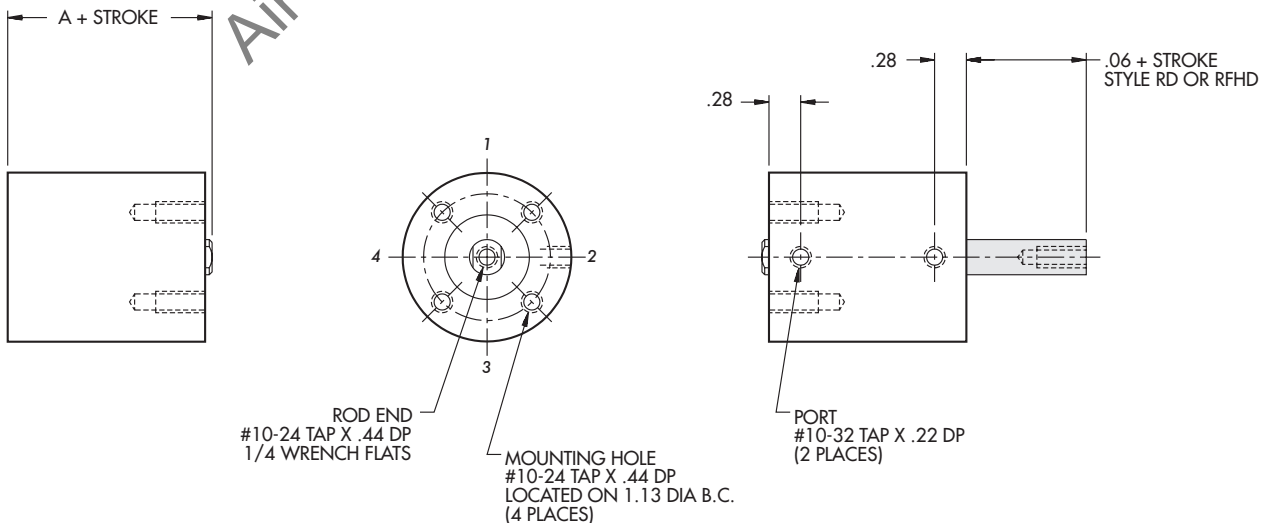





# 3/4" Bore Magnetic Piston

THIRD ANGLE PROJECTION



Duty	Part Number		Standard Stroke Length	A
	Single Rod	Double Rod		
Standard	AR34x__	ARD34x__	1/8 to 1/2 in 1/8" increments	1.06
Intermediate	ARHH34x__		1/8, 1/4	1.31

Standard Mounting: **TF, TR, TBE**    Optional Mounting: **TM**    Optional Porting: **1/8-27 NPTF**

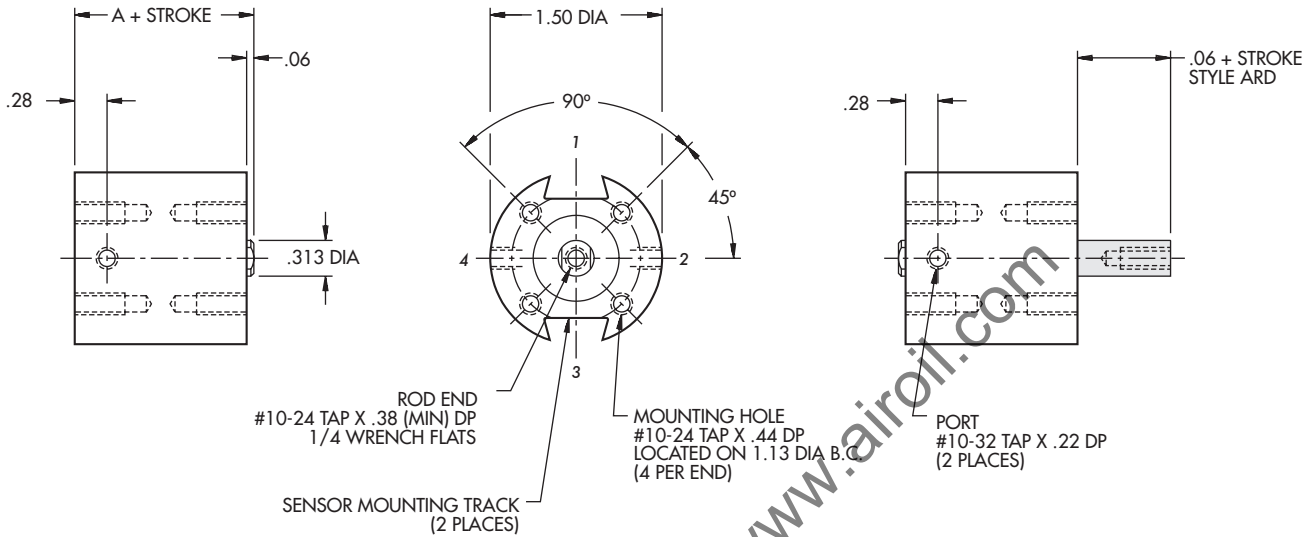

Duty	Part Number		Standard Stroke Length	A
	Single Rod	Double Rod		
Standard	AR34x__	ARD34x__	5/8 to 6 in 1/8" increments	1.06
Intermediate	ARHH34x__		3/8 to 6 in 1/8" increments	1.31
Heavy	ARFH34x__	ARFHD34x__	1/8 to 6 in 1/8" increments	1.56

Standard Mounting: **TF**    Optional Mounting: **TR, TBE, TM**    Optional Porting: **1/8-27 NPTF**

Information same as above except where noted.

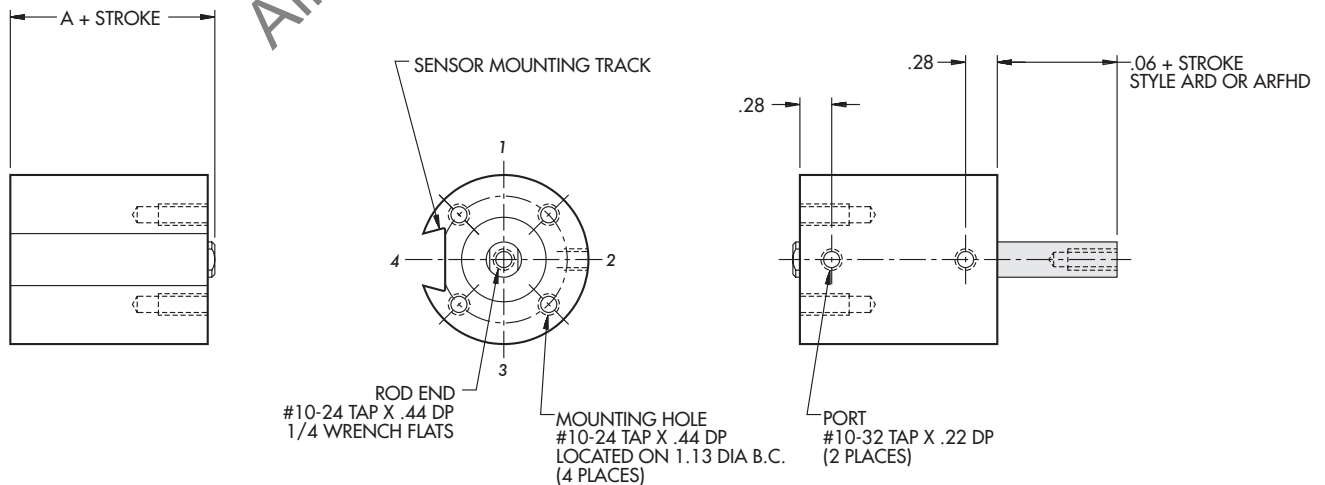



# 1-1/8" Bore Non Magnetic Piston

THIRD ANGLE PROJECTION

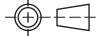

Duty	Part Number		Standard Stroke Length	A
	Single Rod	Double Rod		
Standard	<b>S118x</b> __	<b>SD118x</b> __	1/8 to 3/4 in 1/8" increments	.88
Intermediate	<b>SHH118x</b> __		1/8 to 1/2 in 1/8" increments	1.13
Heavy	<b>SFH118x</b> __	<b>SFHD118x</b> __	1/8 to 1/4 in 1/8" increments	1.38

Standard Mounting: **TF, TR, TBE, TM**

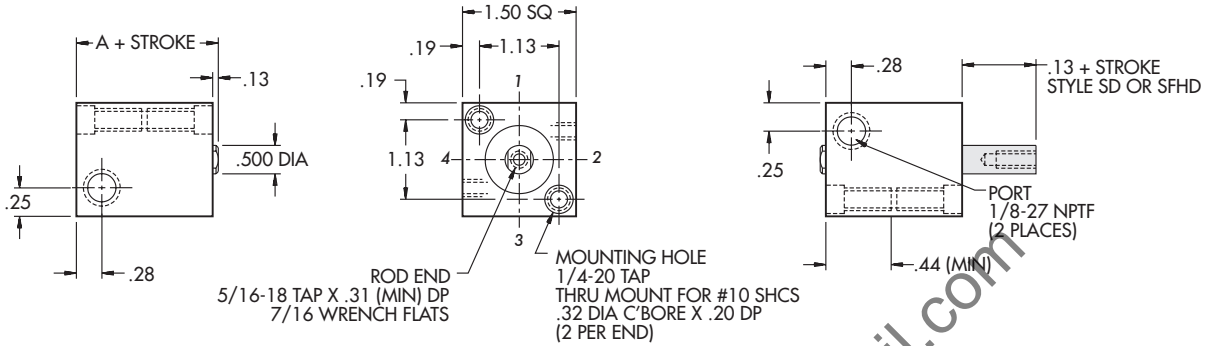

Duty	Part Number		Standard Stroke Length	A
	Single Rod	Double Rod		
Standard	<b>S118x</b> __	<b>SD118x</b> __	7/8, 1	.88
Intermediate	<b>SHH118x</b> __		5/8, 3/4	1.13
Heavy	<b>SFH118x</b> __	<b>SFHD118x</b> __	3/8, 1/2	1.38

Standard Mounting: **TF, TR, TBE, TM**

Information same as above except where noted.

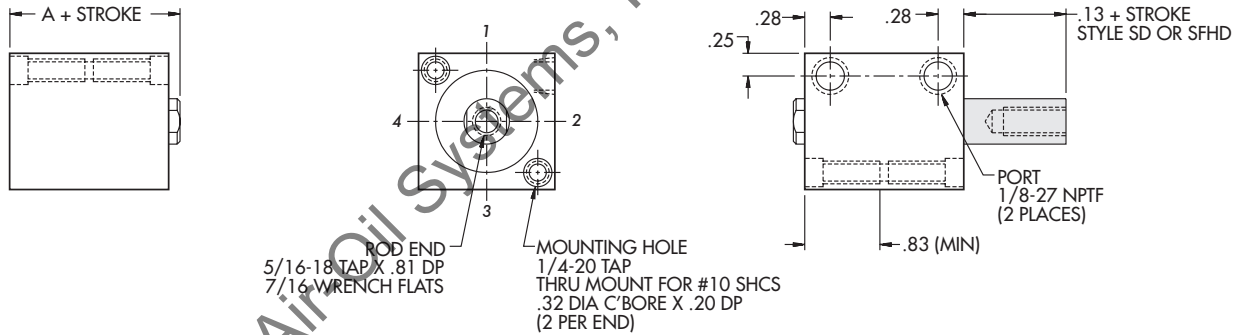

Duty	Part Number		Standard Stroke Length	A
	Single Rod	Double Rod		
Standard	<b>S118x</b> __	<b>SD118x</b> __	1-1/8 to 6 in 1/8" increments	.88
Intermediate	<b>SHH118x</b> __		7/8 to 6 in 1/8" increments	1.13
Heavy	<b>SFH118x</b> __	<b>SFHD118x</b> __	5/8 to 6 in 1/8" increments	1.38

Standard Mounting: **TF** Optional Mounting: **TR, TBE, TM**

Information same as above except where noted.

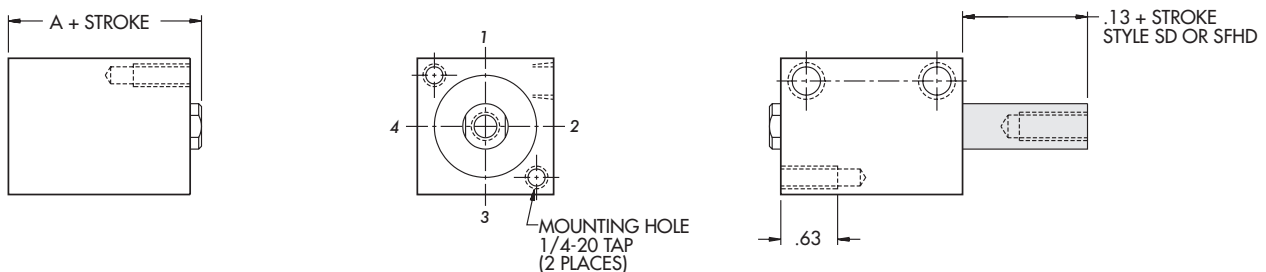



# 1-1/8" Bore Magnetic Piston

THIRD ANGLE PROJECTION

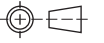

Duty	Part Number		Standard Stroke Length	A
	Single Rod	Double Rod		
Standard	<b>AS118x</b> __	<b>ASD118x</b> __	1/8 to 1/2 in 1/8" increments	1.13
Intermediate	<b>ASHH118x</b> __		1/8 to 1/4 in 1/8" increments	1.38

Standard Mounting: **TF, TR, TBE, TM**

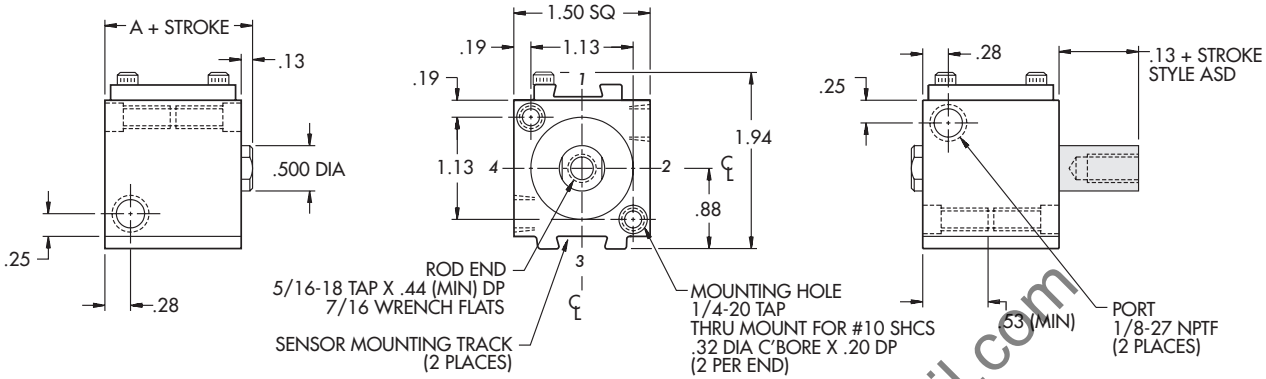

Duty	Part Number		Standard Stroke Length	A
	Single Rod	Double Rod		
Standard	<b>AS118x</b> __	<b>ASD118x</b> __	5/8, 3/4	1.13
Intermediate	<b>ASHH118x</b> __		3/8, 1/2	1.38
Heavy	<b>ASFH118x</b> __	<b>ASFHD118x</b> __	1/8, 1/4	1.63

Standard Mounting: **TF, TR, TBE, TM**

Information same as above except where noted.

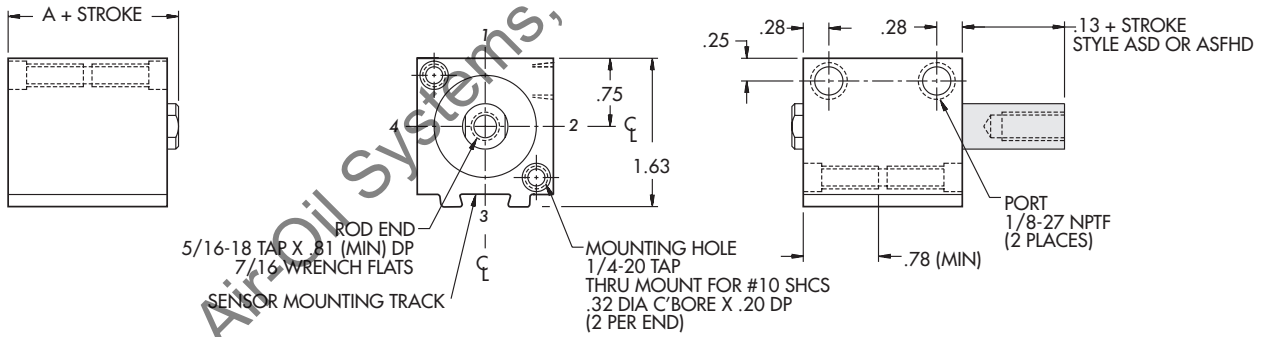

Duty	Part Number		Standard Stroke Length	A
	Single Rod	Double Rod		
Standard	<b>AS118x</b> __	<b>ASD118x</b> __	7/8 to 6 in 1/8" increments	1.13
Intermediate	<b>ASHH118x</b> __		5/8 to 6 in 1/8" increments	1.38
Heavy	<b>ASFH118x</b> __	<b>ASFHD118x</b> __	3/8 to 6 in 1/8" increments	1.63

Standard Mounting: **TF** Optional Mounting: **TR, TBE, TM**

Information same as above except where noted.

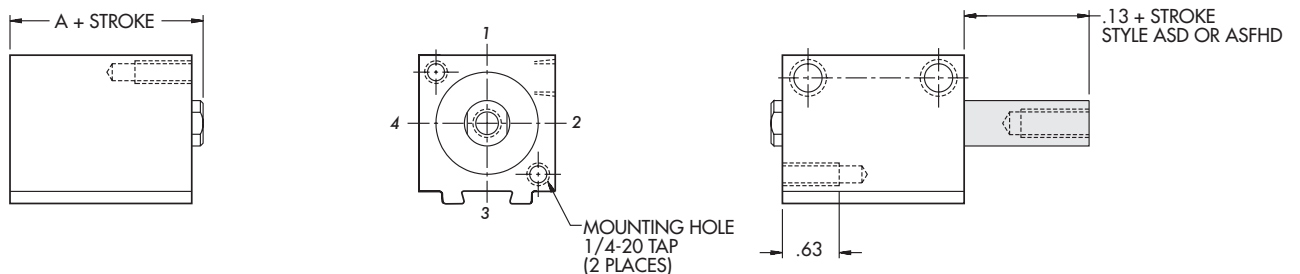

Style "B"



Side Mount

# 1-1/8" Bore Non Magnetic Piston

Duty	Part Number		Standard Stroke Length	A
	Single Rod	Double Rod		
Standard	<b>B118x</b> __	<b>BD118x</b> __	1/8 to 3/4 in 1/8" increments	.88
Intermediate	<b>BHH118x</b> __		1/8 to 1/2 in 1/8" increments	1.13
Heavy	<b>BFH118x</b> __	<b>BFHD118x</b> __	1/8, 1/4	1.38

THIRD ANGLE PROJECTION

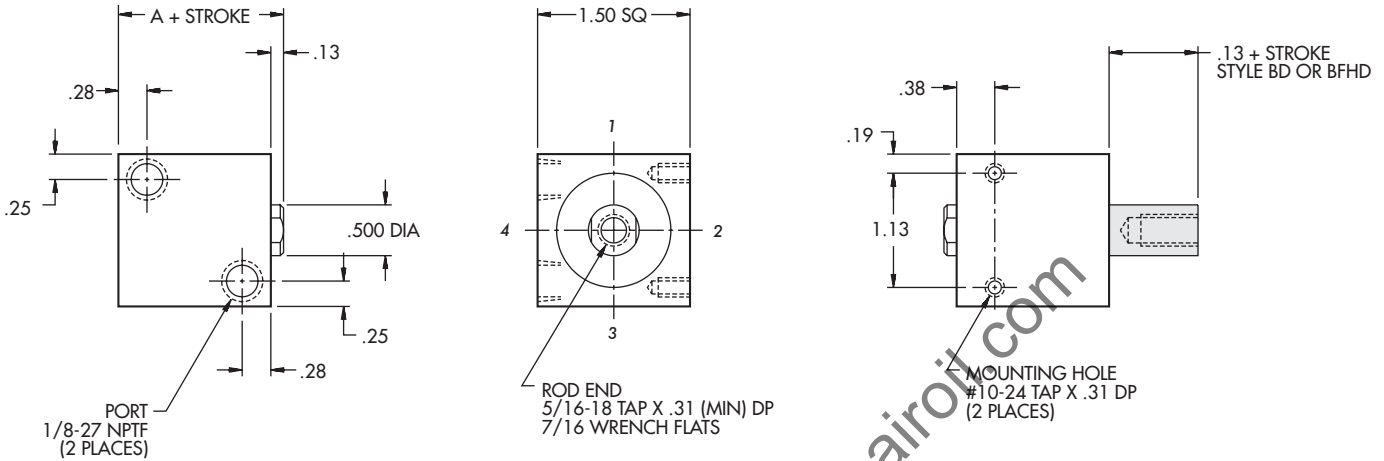
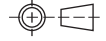

Duty	Part Number		Standard Stroke Length	A
	Single Rod	Double Rod		
Standard	<b>B118x</b> __	<b>BD118x</b> __	7/8 to 6 in 1/8" increments	.88
Intermediate	<b>BHH118x</b> __		5/8 to 6 in 1/8" increments	1.13
Heavy	<b>BFH118x</b> __	<b>BFHD118x</b> __	3/8 to 6 in 1/8" increments	1.38

Information same as above except where noted.

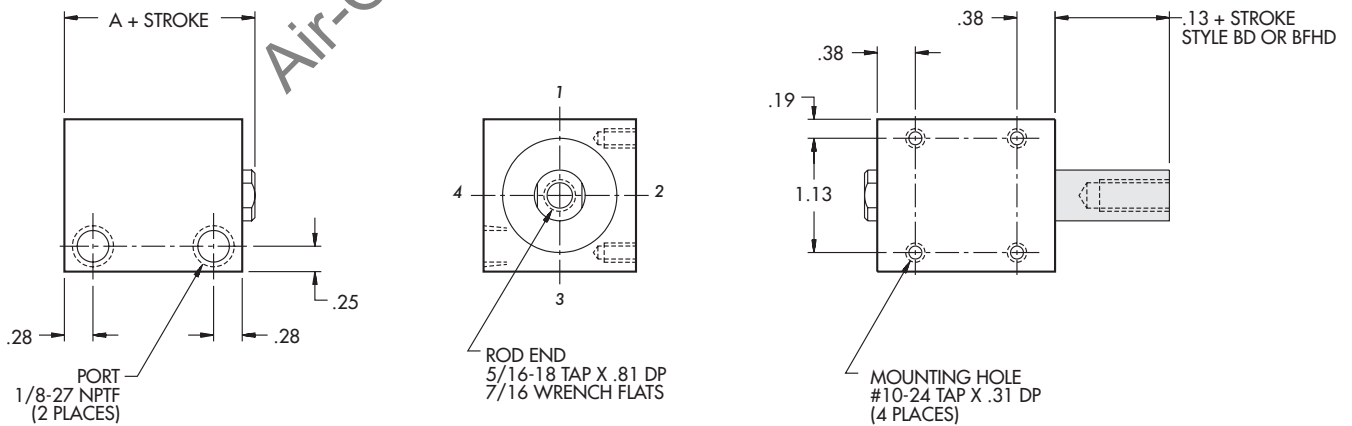



# 1-1/8" Bore Magnetic Piston

THIRD ANGLE PROJECTION

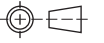

Duty	Part Number		Standard Stroke Length	A
	Single Rod	Double Rod		
Standard	<b>AB118x</b> __	<b>ABD118x</b> __	1/8 to 1/2 in 1/8" increments	1.13
Intermediate	<b>ABHH118x</b> __		1/8, 1/4	1.38

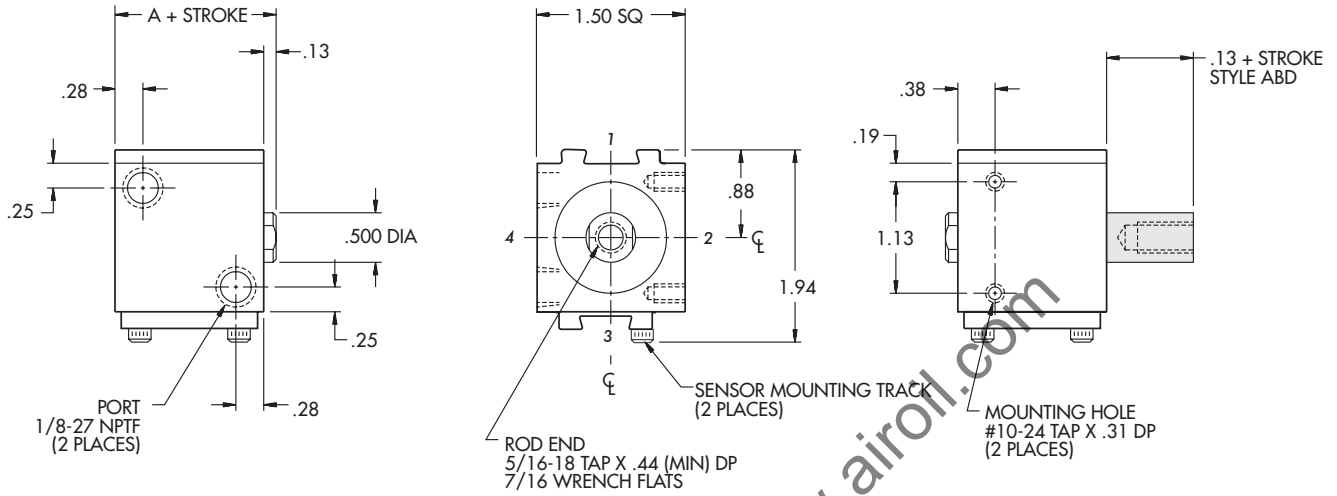

Duty	Part Number		Standard Stroke Length	A
	Single Rod	Double Rod		
Standard	<b>AB118x</b> __	<b>ABD118x</b> __	5/8 to 6 in 1/8" increments	1.13
Intermediate	<b>ABHH118x</b> __		3/8 to 6 in 1/8" increments	1.38
Heavy	<b>ABFH118x</b> __	<b>ABFHD118x</b> __	1/8 to 6 in 1/8" increments	1.63

Information same as above except where noted.

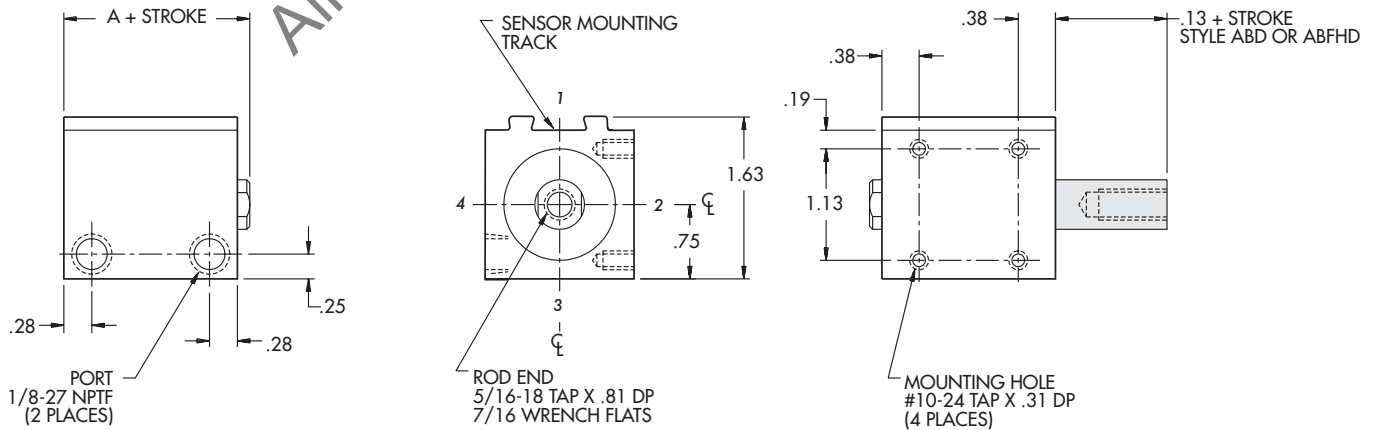



# 1-1/8" Bore Non Magnetic Piston

THIRD ANGLE PROJECTION

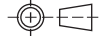

Duty	Part Number		Standard Stroke Length	A
	Single Rod	Double Rod		
Standard	<b>R118x</b> __	<b>RD118x</b> __	1/8 to 3/4 in 1/8" increments	.88
Intermediate	<b>RHH118x</b> __		1/8 to 1/2 in 1/8" increments	1.13
Heavy	<b>RFH118x</b> __	<b>RFHD118x</b> __	1/8, 1/4	1.38

Standard Mounting: **TF, TR, TBE**    Optional Mounting: **TM**

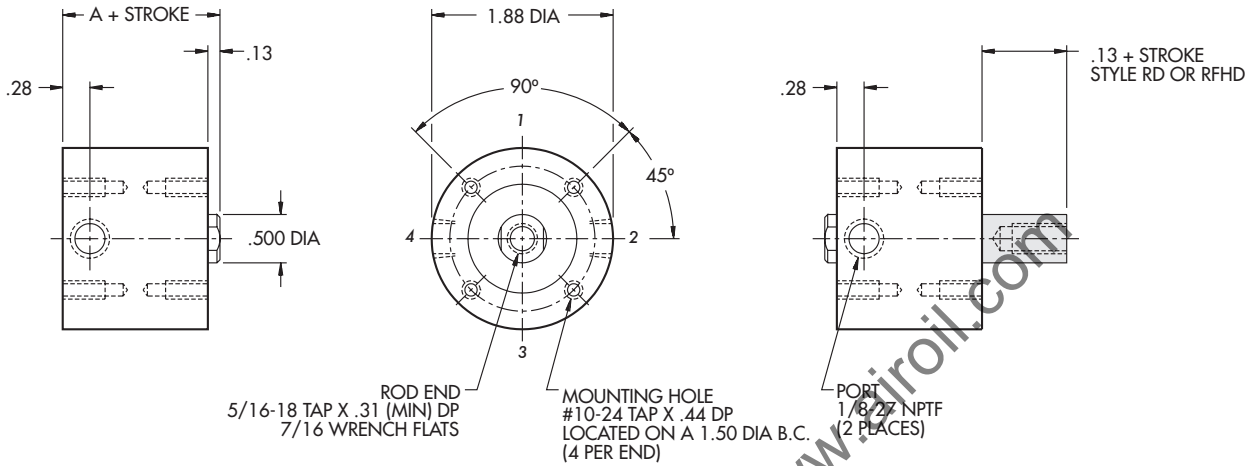

Duty	Part Number		Standard Stroke Length	A
	Single Rod	Double Rod		
Standard	<b>R118x</b> __	<b>RD118x</b> __	7/8 to 6 in 1/8" increments	.88
Intermediate	<b>RHH118x</b> __		5/8 to 6 in 1/8" increments	1.13
Heavy	<b>RFH118x</b> __	<b>RFHD118x</b> __	3/8 to 6 in 1/8" increments	1.38

Standard Mounting: **TF**    Optional Mounting: **TR, TBE, TM**

Information same as above except where noted.

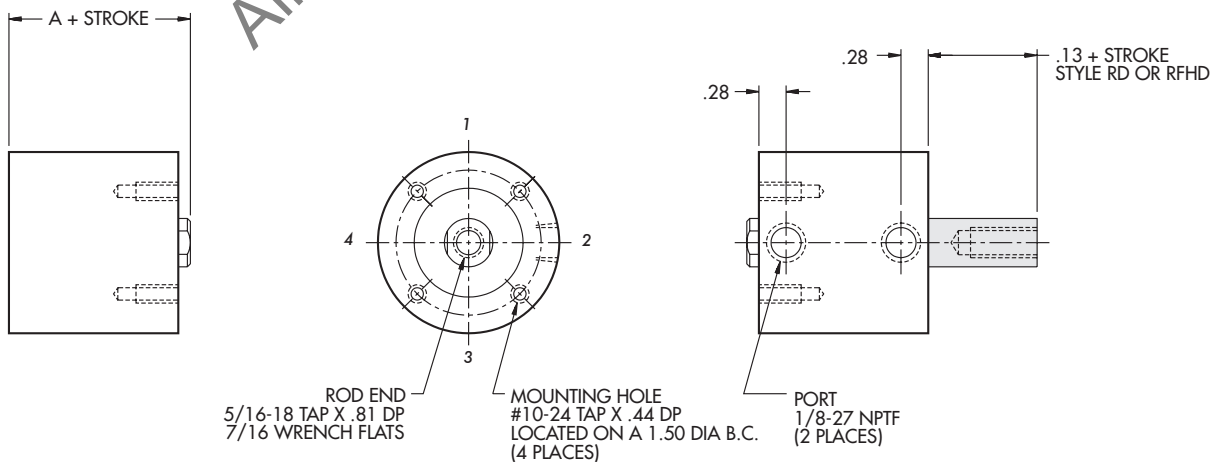





# 1-1/8" Bore Magnetic Piston

THIRD ANGLE PROJECTION

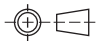

Duty	Part Number		Standard Stroke Length	A
	Single Rod	Double Rod		
Standard	AR118x__	ARD118x__	1/8 to 1/2 in 1/8" increments	1.13
Intermediate	ARHH118x__		1/8, 1/4	1.38

Standard Mounting: **TF, TR, TBE**    Optional Mounting: **TM**

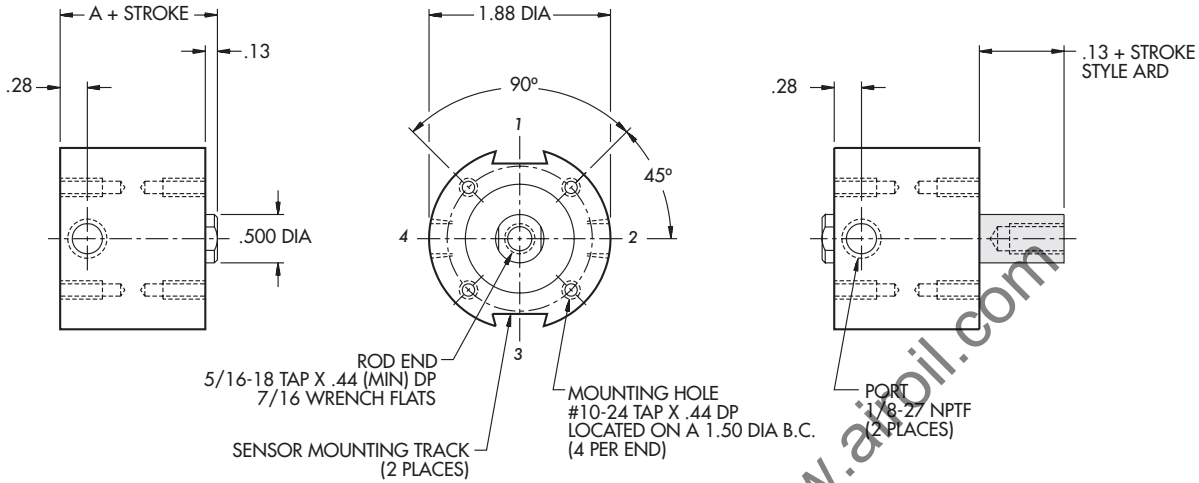

Duty	Part Number		Standard Stroke Length	A
	Single Rod	Double Rod		
Standard	AR118x__	ARD118x__	3/8 to 6 in 1/8" increments	1.13
Intermediate	ARHH118x__		3/8 to 6 in 1/8" increments	1.38
Heavy	ARFH118x__	ARFHD118x__	1/8 to 6 in 1/8" increments	1.63

Standard Mounting: **TF**    Optional Mounting: **TR, TBE, TM**

Information same as above except where noted.

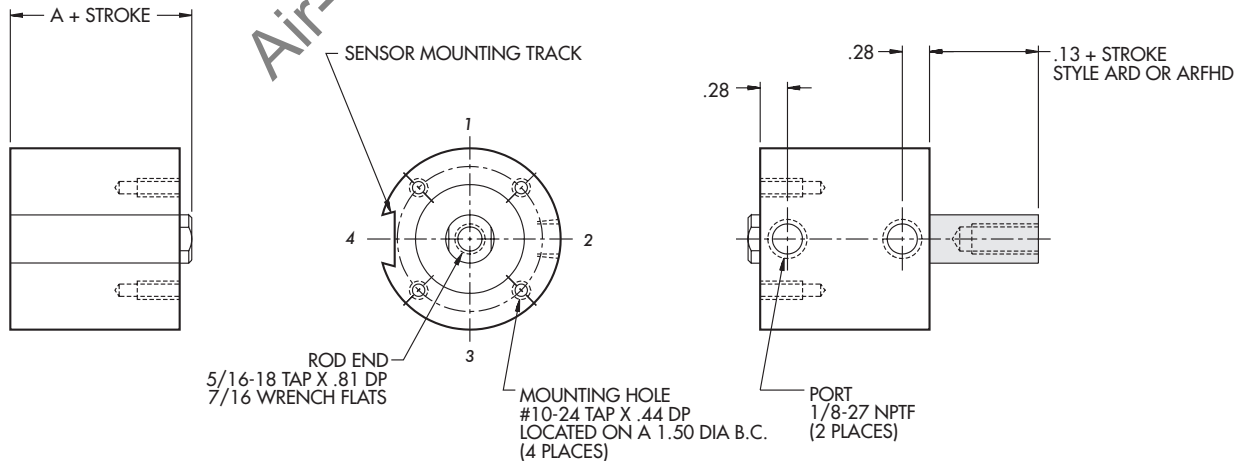



# 1-3/8" Bore Non Magnetic Piston

THIRD ANGLE PROJECTION

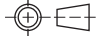

Duty	Part Number		Standard Stroke Length	A
	Single Rod	Double Rod		
Standard	<b>S138x</b> __	<b>SD138x</b> __	1/8 to 3/4 in 1/8" increments	1.13
Intermediate	<b>SHH138x</b> __		1/8 to 1/2 in 1/8" increments	1.38
Heavy	<b>SFH138x</b> __	<b>SFHD138x</b> __	1/8, 1/4	1.63

Standard Mounting: **TF, TR, TBE, TM**

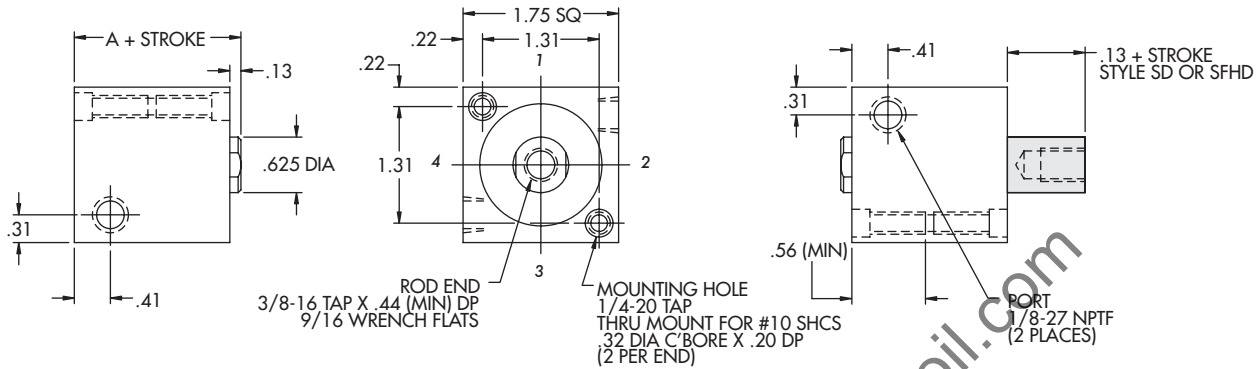

Duty	Part Number		Standard Stroke Length	A
	Single Rod	Double Rod		
Standard	<b>S138x</b> __	<b>SD138x</b> __	7/8, 1	1.13
Intermediate	<b>SHH138x</b> __		5/8, 3/4	1.38
Heavy	<b>SFH138x</b> __	<b>SFHD138x</b> __	3/8, 1/2	1.63

Standard Mounting: **TF, TR, TBE, TM**

Information same as above except where noted.

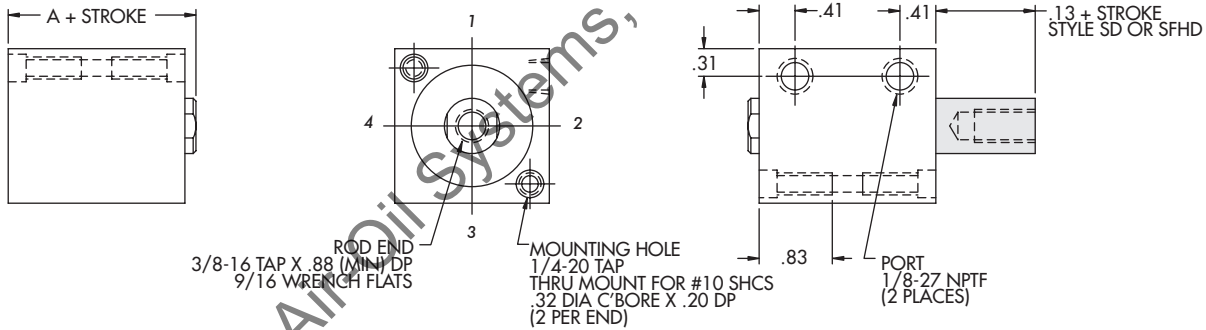

Duty	Part Number		Standard Stroke Length	A
	Single Rod	Double Rod		
Standard	<b>S138x</b> __	<b>SD138x</b> __	1-1/8 to 6 in 1/8" increments	1.13
Intermediate	<b>SHH138x</b> __		7/8 to 6 in 1/8" increments	1.38
Heavy	<b>SFH138x</b> __	<b>SFHD138x</b> __	5/8 to 6 in 1/8" increments	1.63

Standard Mounting: **TF** Optional Mounting: **TR, TBE, TM**

Information same as above except where noted.

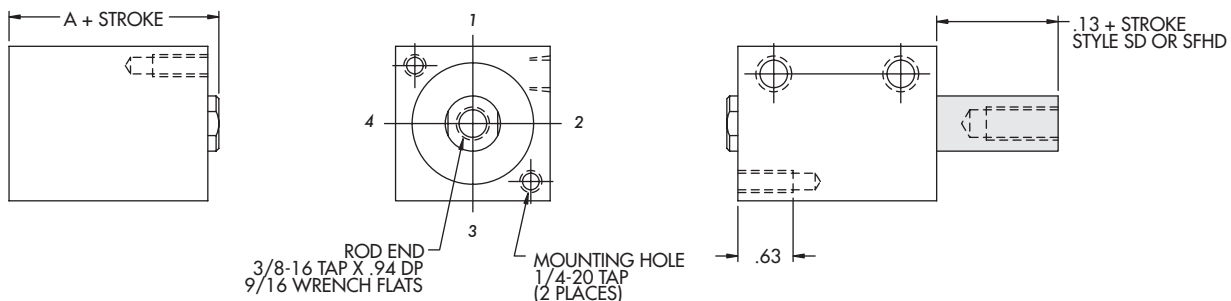



Style "B"



Side Mount

# 1-3/8" Bore Non Magnetic Piston

Duty	Part Number		Standard Stroke Length	A
	Single Rod	Double Rod		
Standard	<b>B138x</b> __	<b>BD138x</b> __	1/8 to 3/4 in 1/8" increments	1.13
Intermediate	<b>BHH138x</b> __		1/8 to 1/2 in 1/8" increments	1.38
Heavy	<b>BFH138x</b> __	<b>BFHD138x</b> __	1/8, 1/4	1.63

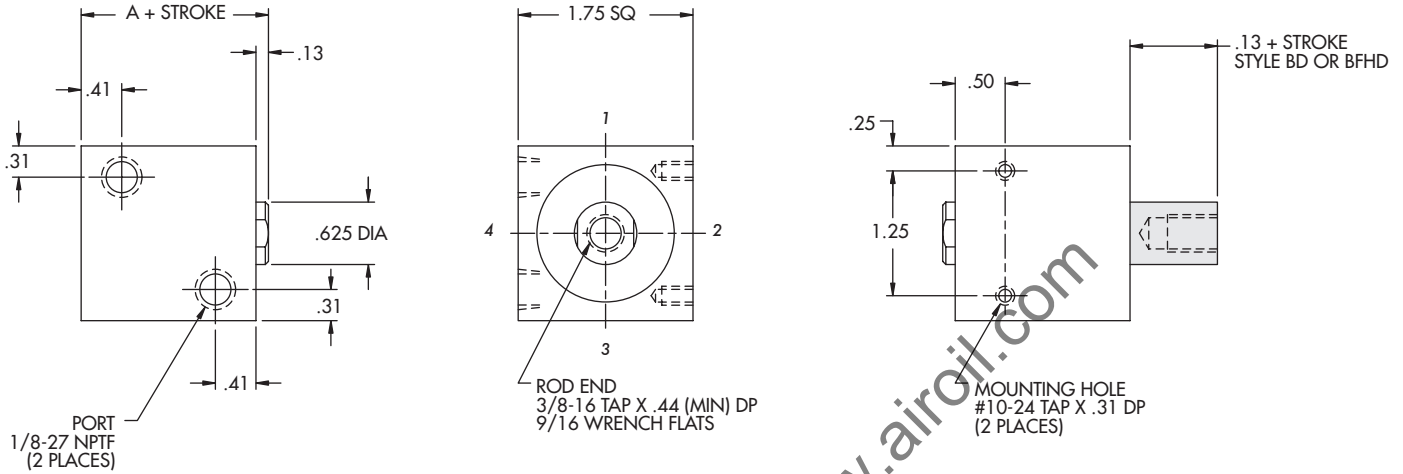
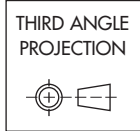

Duty	Part Number		Standard Stroke Length	A
	Single Rod	Double Rod		
Standard	<b>B138x</b> __	<b>BD138x</b> __	7/8 to 6 in 1/8" increments	1.13
Intermediate	<b>BHH138x</b> __		5/8 to 6 in 1/8" increments	1.38
Heavy	<b>BFH138x</b> __	<b>BFHD138x</b> __	3/8 to 6 in 1/8" increments	1.63

Information same as above except where noted.

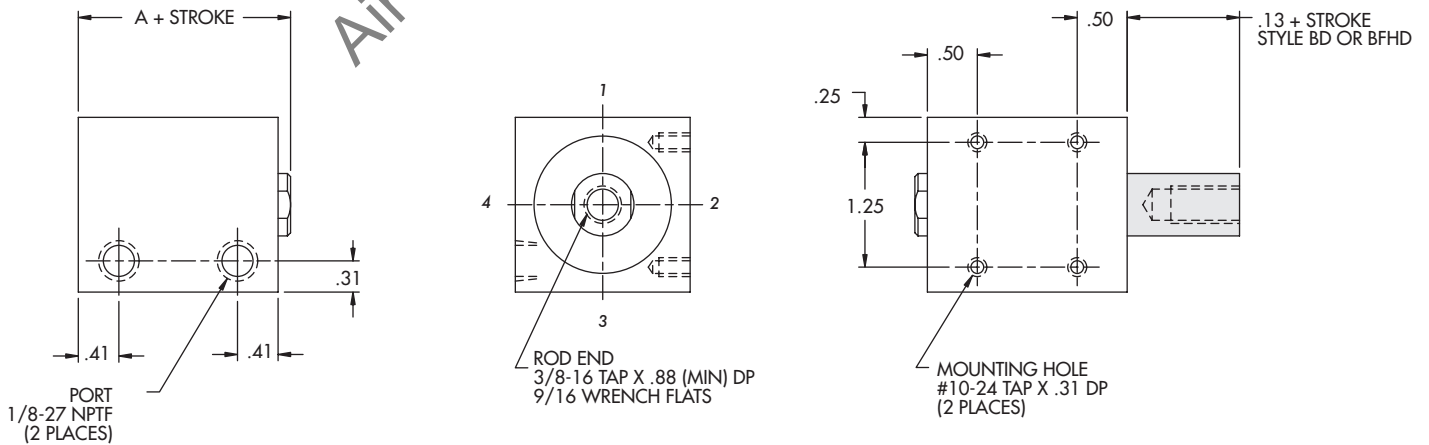



# 1-3/8" Bore Magnetic Piston

THIRD ANGLE PROJECTION

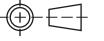

Duty	Part Number		Standard Stroke Length	A
	Single Rod	Double Rod		
Standard	<b>AB138x</b> __	<b>ABD138x</b> __	1/8 to 1/2 in 1/8" increments	1.38
Intermediate	<b>ABHH138x</b> __		1/8, 1/4	1.63

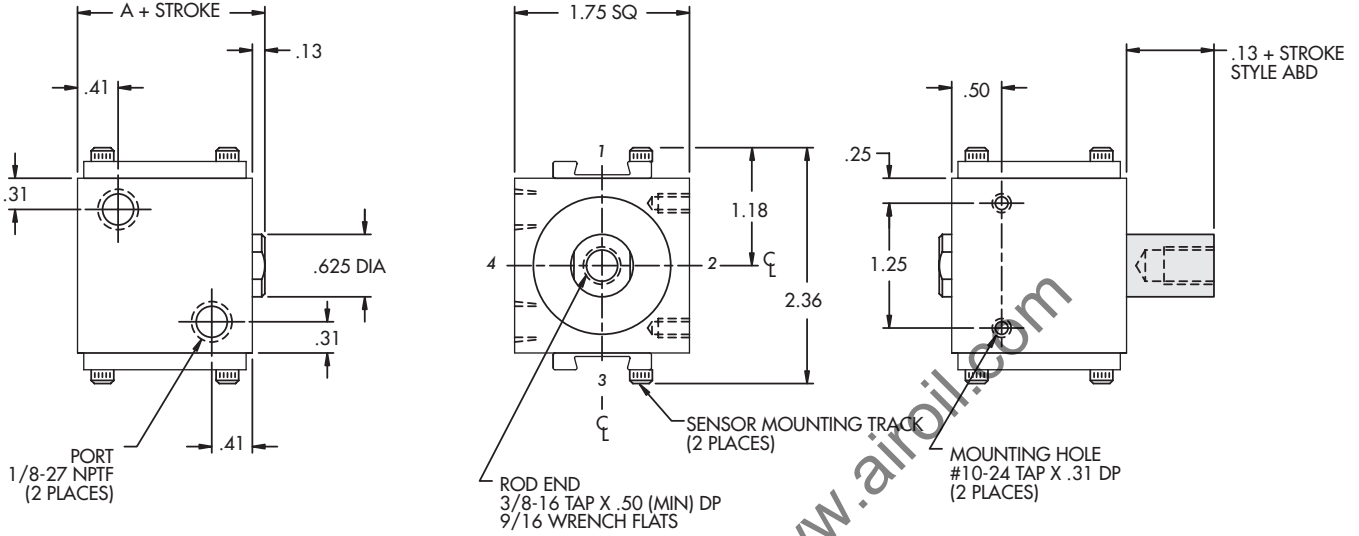

Duty	Part Number		Standard Stroke Length	A
	Single Rod	Double Rod		
Standard	<b>AB138x</b> __	<b>ABD138x</b> __	5/8 to 6 in 1/8" increments	1.38
Intermediate	<b>ABHH138x</b> __		3/8 to 6 in 1/8" increments	1.63
Heavy	<b>ABFH138x</b> __	<b>ABFHD138x</b> __	1/8 to 6 in 1/8" increments	1.88

Information same as above except where noted.

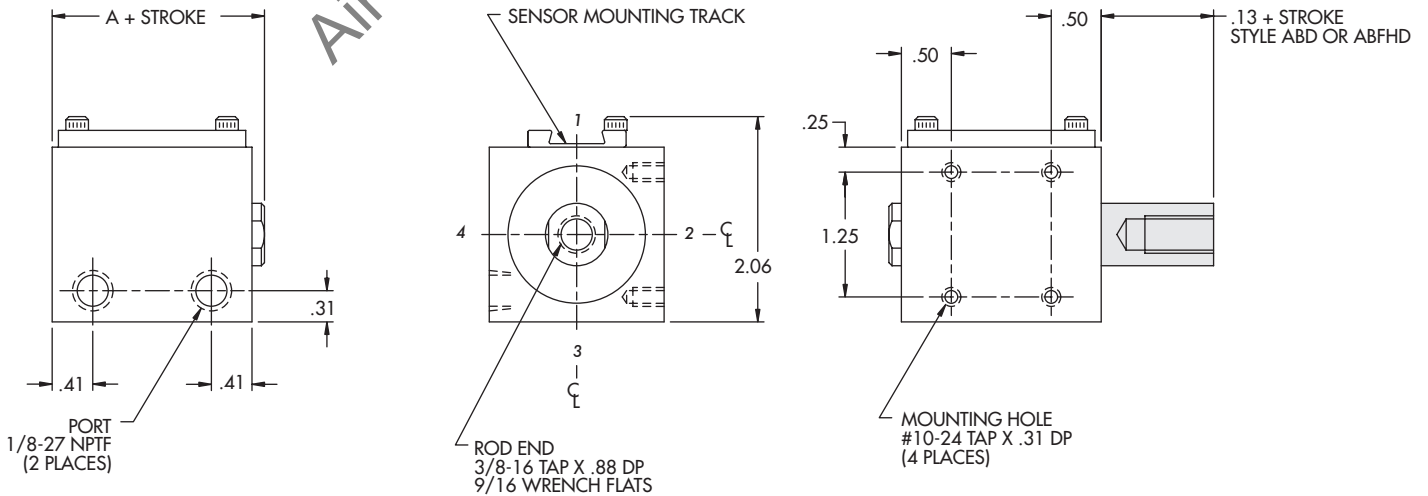

Style "R"



End Mount

# 1-3/8" Bore Non Magnetic Piston

Duty	Part Number		Standard Stroke Length	A
	Single Rod	Double Rod		
Standard	<b>R138x</b> __	<b>RD138x</b> __	1/8 to 3/4 in 1/8" increments	1.13
Intermediate	<b>RHH138x</b> __		1/8 to 1/2 in 1/8" increments	1.38
Heavy	<b>RFH138x</b> __	<b>RFHD138x</b> __	1/8, 1/4	1.63

THIRD ANGLE PROJECTION

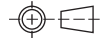

Standard Mounting: **TF, TR, TBE**    Optional Mounting: **TM**

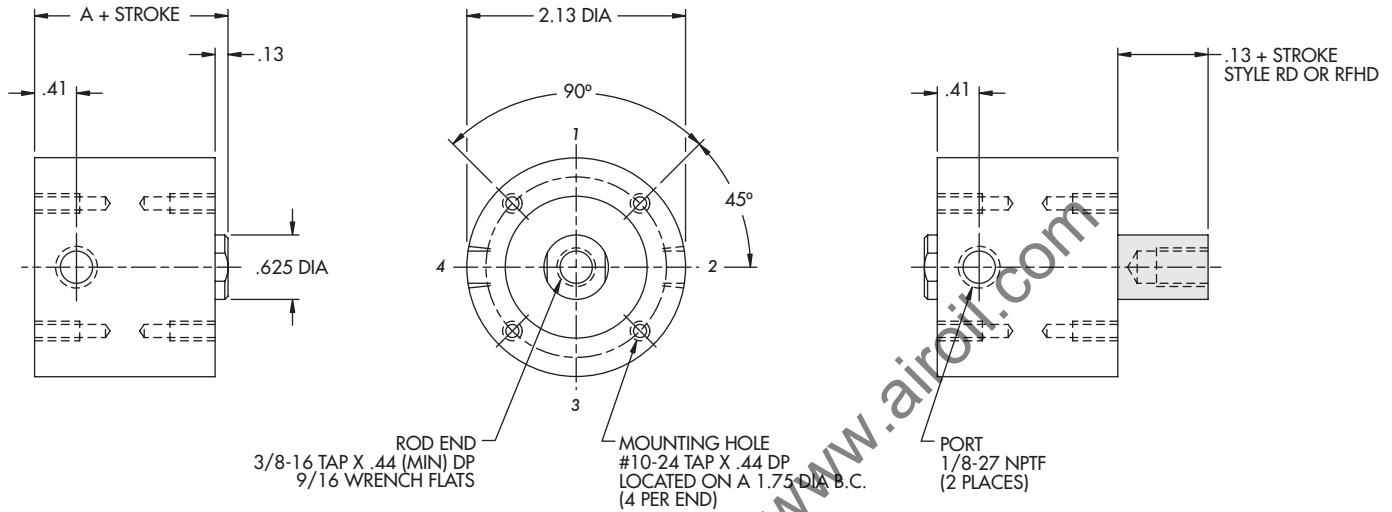

Duty	Part Number		Standard Stroke Length	A
	Single Rod	Double Rod		
Standard	<b>R138x</b> __	<b>RD138x</b> __	7/8 to 6 in 1/8" increments	1.13
Intermediate	<b>RHH138x</b> __		5/8 to 6 in 1/8" increments	1.38
Heavy	<b>RFH138x</b> __	<b>RFHD138x</b> __	3/8 to 6 in 1/8" increments	1.63

Standard Mounting: **TF**    Optional Mounting: **TR, TBE, TM**  
 Information same as above except where noted.

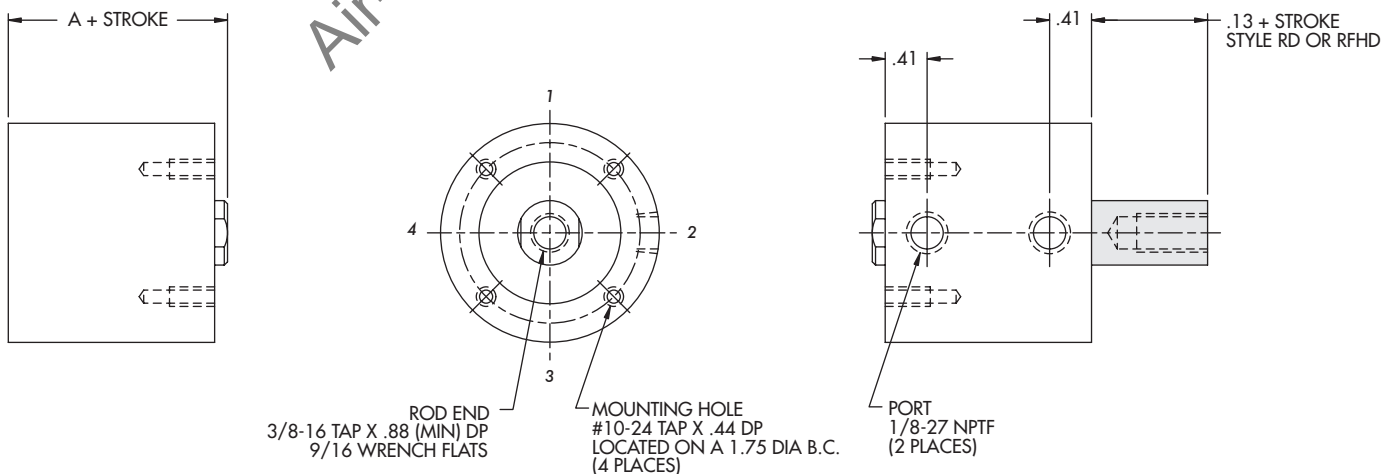



# 1-3/8" Bore Magnetic Piston

THIRD ANGLE PROJECTION

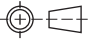

Duty	Part Number		Standard Stroke Length	A
	Single Rod	Double Rod		
Standard	<b>AR138x</b> __	<b>ARD138x</b> __	1/8 to 1/2 in 1/8" increments	1.38
Intermediate	<b>ARHH138x</b> __		1/8, 1/4	1.63

Standard Mounting: **TF, TR, TBE**    Optional Mounting: **TM**

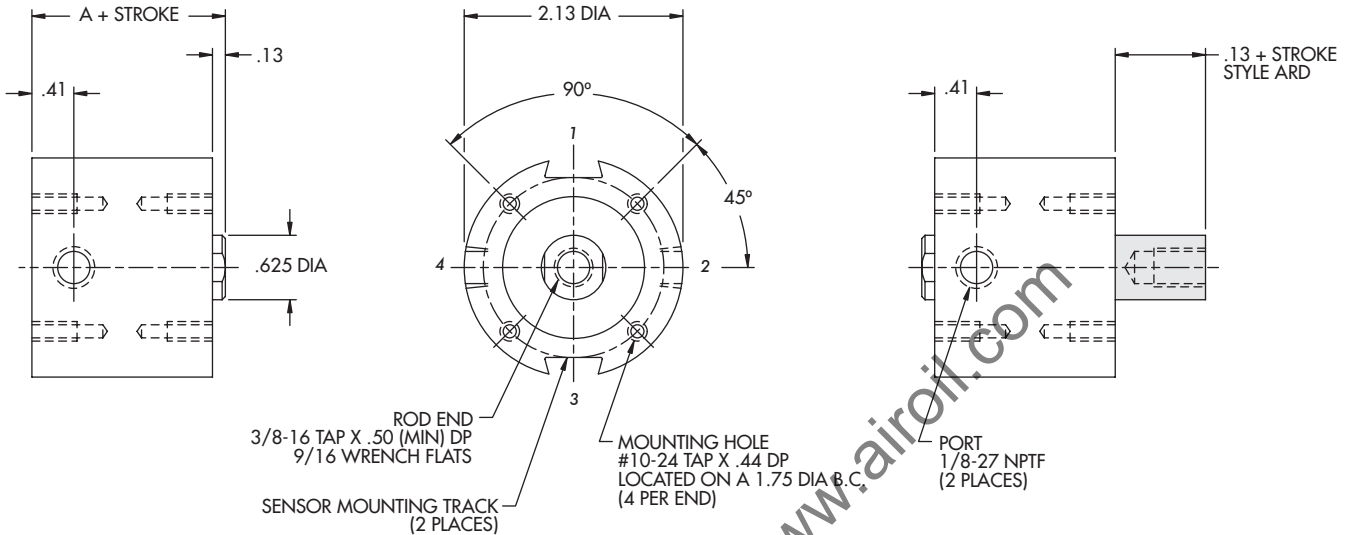

Duty	Part Number		Standard Stroke Length	A
	Single Rod	Double Rod		
Standard	<b>AR138x</b> __	<b>ARD138x</b> __	5/8 to 6 in 1/8" increments	1.38
Intermediate	<b>ARHH138x</b> __		3/8 to 6 in 1/8" increments	1.63
Heavy	<b>ARFH138x</b> __	<b>ARFHD138x</b> __	1/8 to 6 in 1/8" increments	1.88

Standard Mounting: **TF**    Optional Mounting: **TR, TBE, TM**

Information same as above except where noted.

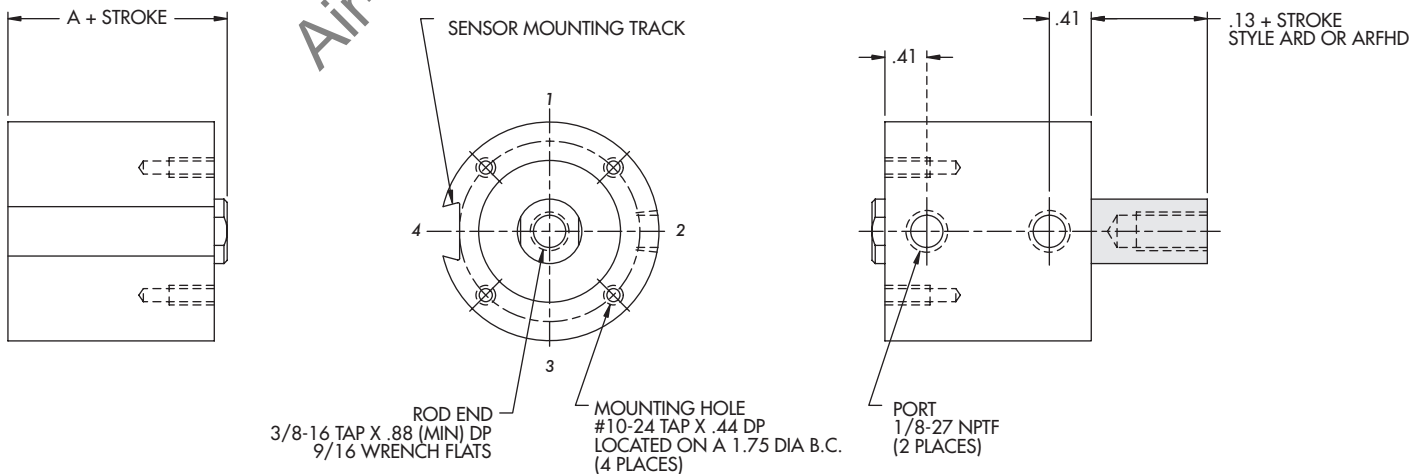



# 1-5/8" Bore Non Magnetic Piston

THIRD ANGLE PROJECTION

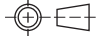

Duty	Part Number		Standard Stroke Length	A
	Single Rod	Double Rod		
Standard	<b>S158x</b> __	<b>SD158x</b> __	1/8 to 3/4 in 1/8" increments	1.13
Intermediate	<b>SHH158x</b> __		1/8 to 1/2 in 1/8" increments	1.38
Heavy	<b>SFH158x</b> __	<b>SFHD158x</b> __	1/8, 1/4	1.63

Standard Mounting: **TF, TR, TBE, TM**

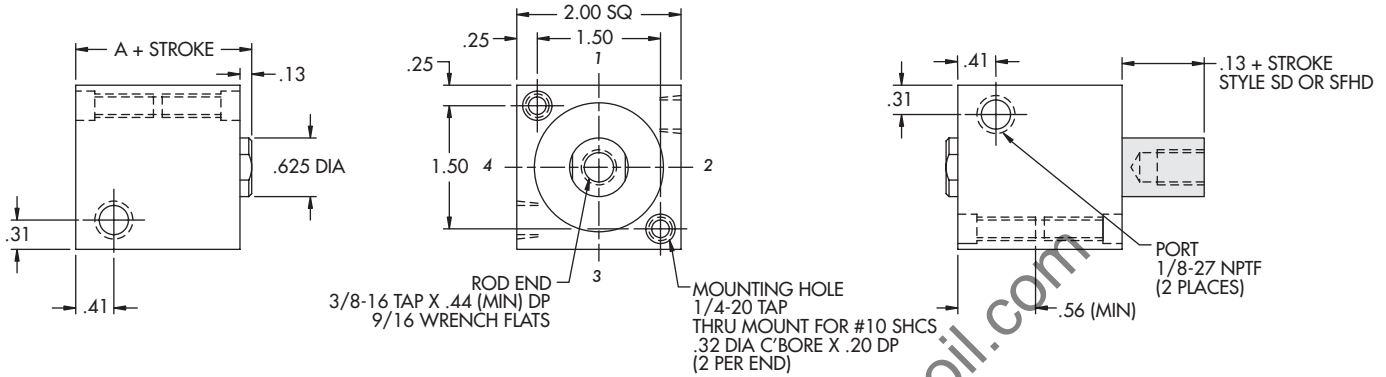

Duty	Part Number		Standard Stroke Length	A
	Single Rod	Double Rod		
Standard	<b>S158x</b> __	<b>SD158x</b> __	7/8, 1	1.13
Intermediate	<b>SHH158x</b> __		5/8, 3/4	1.38
Heavy	<b>SFH158x</b> __	<b>SFHD158x</b> __	3/8, 1/2	1.63

Standard Mounting: **TF, TR, TBE, TM**

Information same as above except where noted.

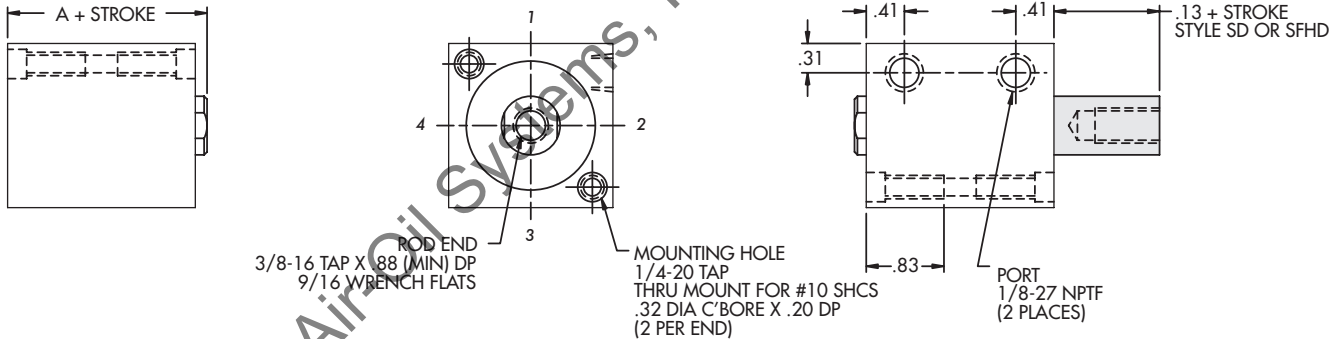

Duty	Part Number		Standard Stroke Length	A
	Single Rod	Double Rod		
Standard	<b>S158x</b> __	<b>SD158x</b> __	1-1/8 to 6 in 1/8" increments	1.13
Intermediate	<b>SHH158x</b> __		7/8 to 6 in 1/8" increments	1.38
Heavy	<b>SFH158x</b> __	<b>SFHD158x</b> __	5/8 to 6 in 1/8" increments	1.63

Standard Mounting: **TF** Optional Mounting: **TR, TBE, TM**

Information same as above except where noted.

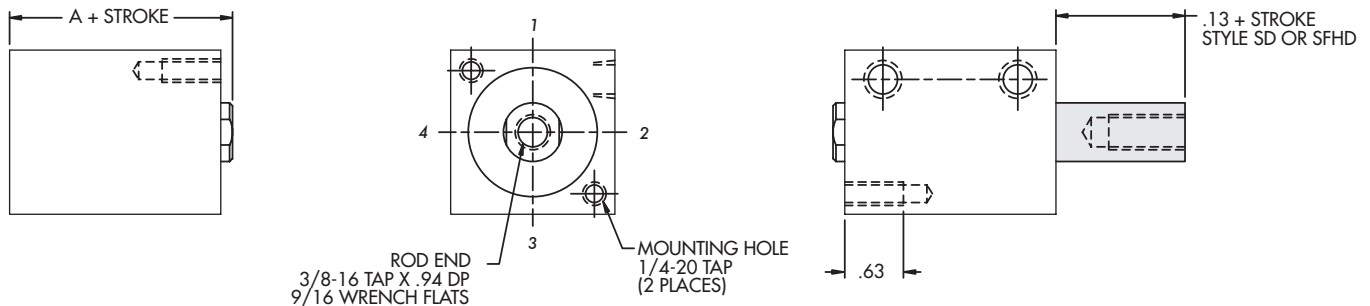





# 1-5/8" Bore Magnetic Piston

THIRD ANGLE PROJECTION

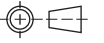

Duty	Part Number		Standard Stroke Length	A
	Single Rod	Double Rod		
Standard	<b>AS158x</b> __	<b>ASD158x</b> __	1/8 to 1/2 in 1/8" increments	1.38
Intermediate	<b>ASHH158x</b> __		1/8, 1/4	1.63

Standard Mounting: **TF, TR, TBE, TM**

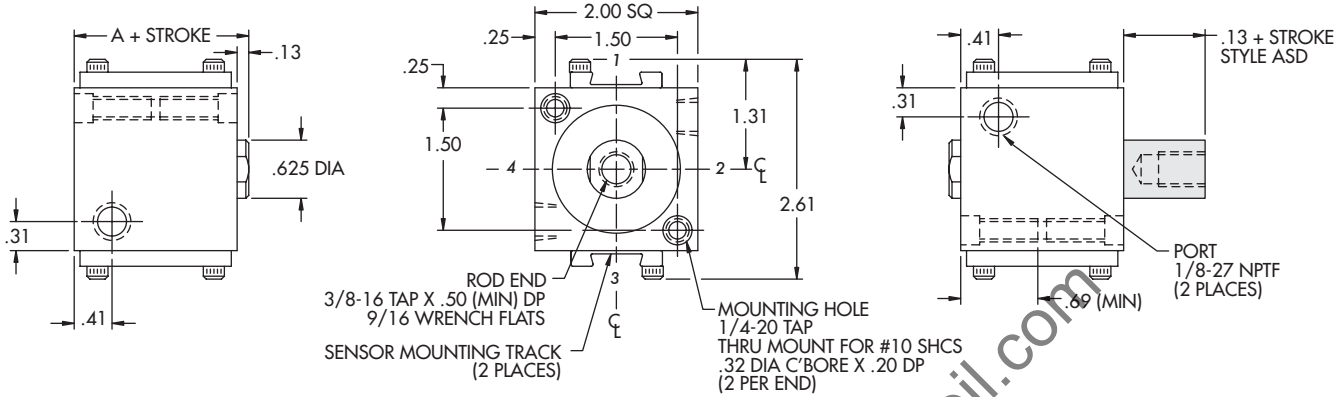

Duty	Part Number		Standard Stroke Length	A
	Single Rod	Double Rod		
Standard	<b>AS158x</b> __	<b>ASD158x</b> __	5/8, 3/4	1.38
Intermediate	<b>ASHH158x</b> __		3/8, 1/2	1.63
Heavy	<b>ASFH158x</b> __	<b>ASFHD158x</b> __	1/8, 1/4	1.88

Standard Mounting: **TF, TR, TBE, TM**

Information same as above except where noted.

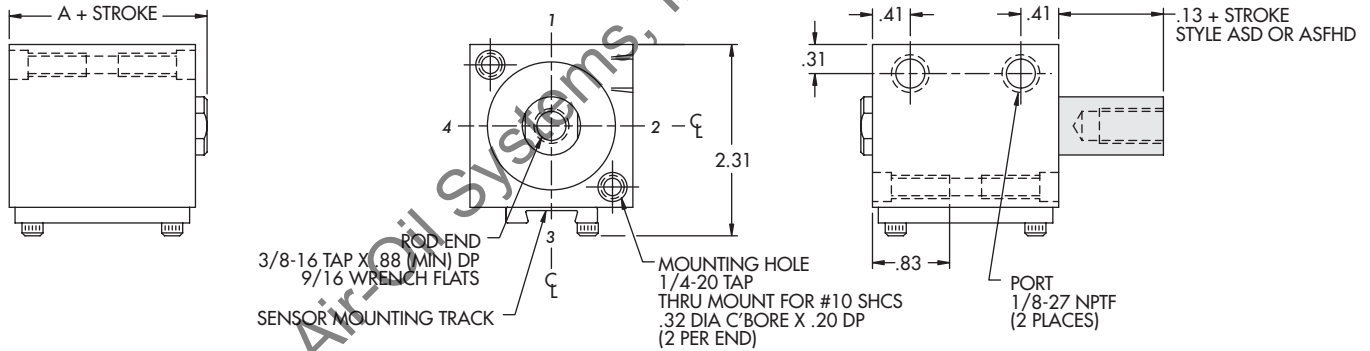

Duty	Part Number		Standard Stroke Length	A
	Single Rod	Double Rod		
Standard	<b>AS158x</b> __	<b>ASD158x</b> __	7/8 to 6 in 1/8" increments	1.38
Intermediate	<b>ASHH158x</b> __		5/8 to 6 in 1/8" increments	1.63
Heavy	<b>ASFH158x</b> __	<b>ASFHD158x</b> __	3/8 to 6 in 1/8" increments	1.88

Standard Mounting: **TF**      Optional Mounting: **TR, TBE, TM**

Information same as above except where noted.

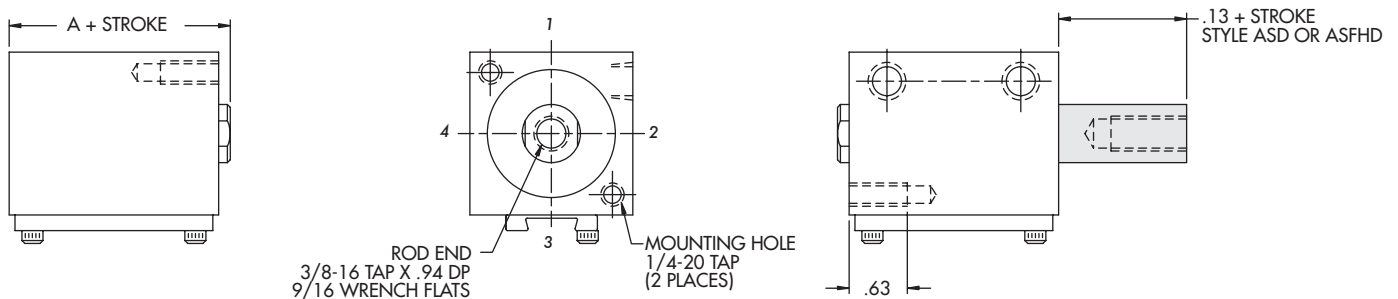

Style "B"



Side Mount

# 1-5/8" Bore Non Magnetic Piston

Duty	Part Number		Standard Stroke Length	A
	Single Rod	Double Rod		
Standard	<b>B158x</b> __	<b>BD158x</b> __	1/8 to 3/4 in 1/8" increments	1.13
Intermediate	<b>BHH158x</b> __		1/8 to 1/2 in 1/8" increments	1.38
Heavy	<b>BFH158x</b> __	<b>BFHD158x</b> __	1/8, 1/4	1.63

THIRD ANGLE PROJECTION

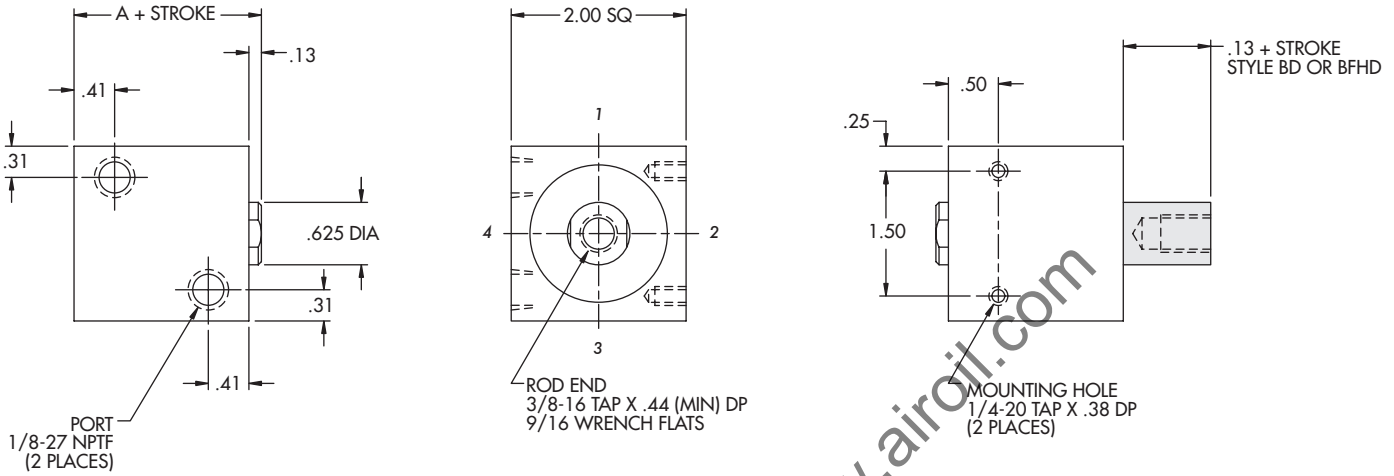
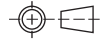

Duty	Part Number		Standard Stroke Length	A
	Single Rod	Double Rod		
Standard	<b>B158x</b> __	<b>BD158x</b> __	7/8 to 6 in 1/8" increments	1.13
Intermediate	<b>BHH158x</b> __		5/8 to 6 in 1/8" increments	1.38
Heavy	<b>BFH158x</b> __	<b>BFHD158x</b> __	3/8 to 6 in 1/8" increments	1.63

Information same as above except where noted.

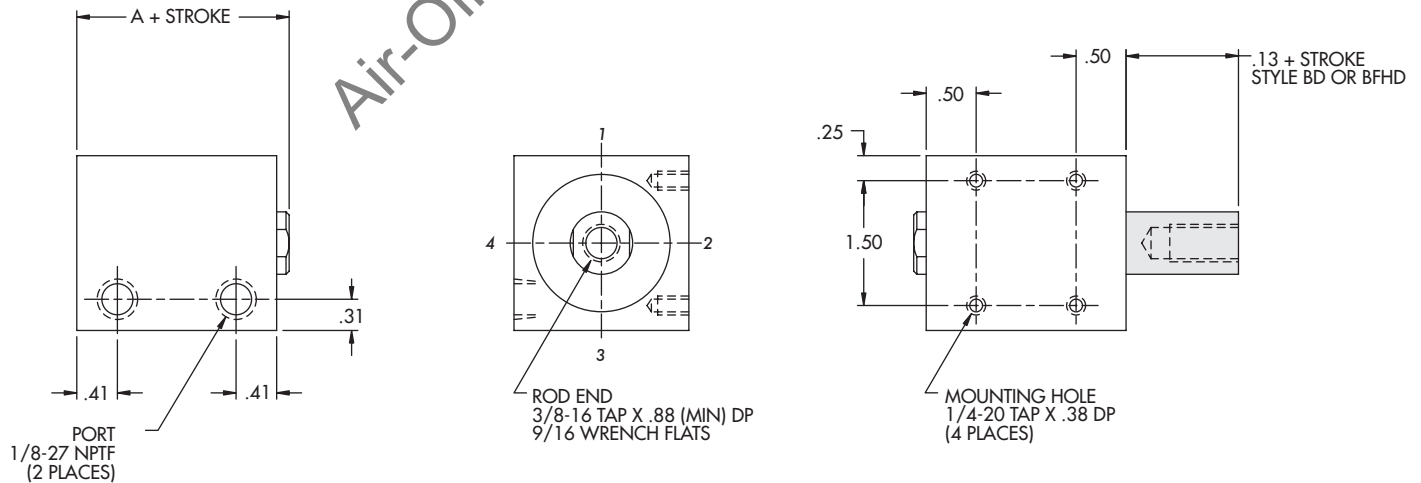



# 1-5/8" Bore Magnetic Piston

THIRD ANGLE PROJECTION



Duty	Part Number		Standard Stroke Length	A
	Single Rod	Double Rod		
Standard	<b>AB158x__</b>	<b>ABD158x__</b>	1/8 to 1/2 in 1/8" increments	1.38
Intermediate	<b>ABHH158x__</b>		1/8, 1/4	1.63

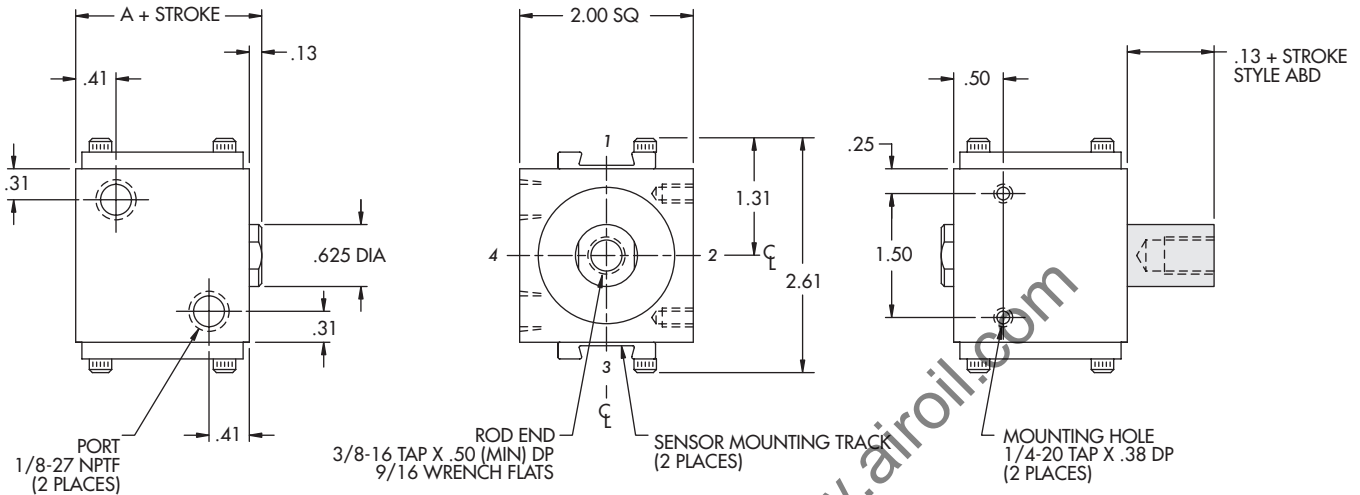

Duty	Part Number		Standard Stroke Length	A
	Single Rod	Double Rod		
Standard	<b>AB158x__</b>	<b>ABD158x__</b>	5/8 to 6 in 1/8" increments	1.38
Intermediate	<b>ABHH158x__</b>		3/8 to 6 in 1/8" increments	1.63
Heavy	<b>ABFH158x__</b>	<b>ABFHD158x__</b>	1/8 to 6 in 1/8" increments	1.88

Information same as above except where noted.

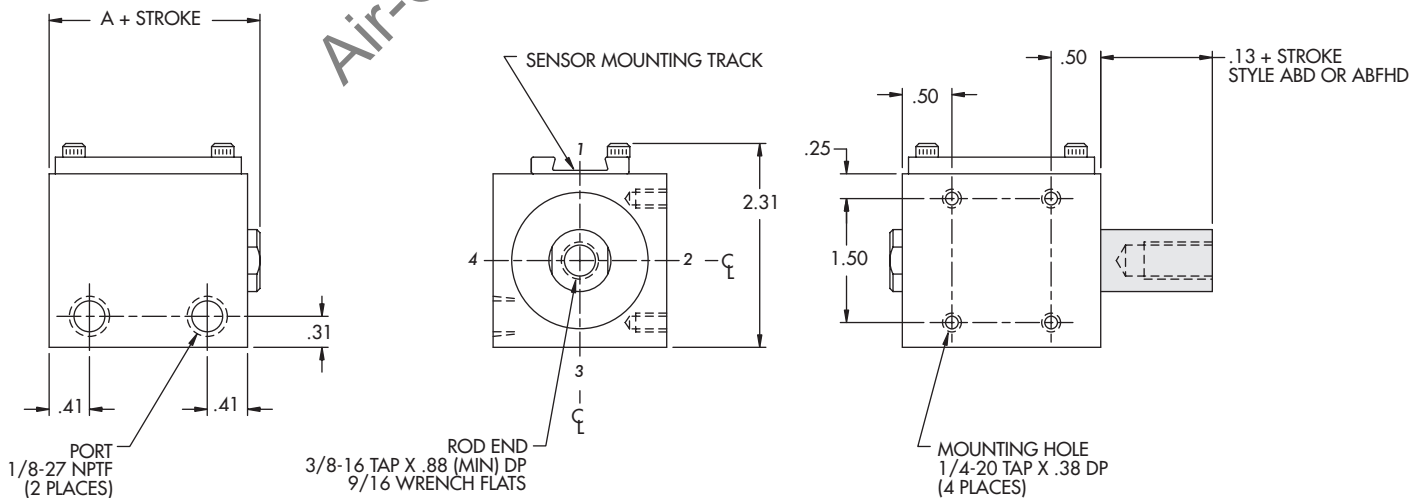

Style "R"



End Mount

# 1-5/8" Bore Non Magnetic Piston

Duty	Part Number		Standard Stroke Length	A
	Single Rod	Double Rod		
Standard	<b>R158x</b> __	<b>RD158x</b> __	1/8 to 3/4 in 1/8" increments	1.13
Intermediate	<b>RHH158x</b> __		1/8 to 1/2 in 1/8" increments	1.38
Heavy	<b>RFH158x</b> __	<b>RFHD158x</b> __	1/8, 1/4	1.63



Standard Mounting: **TF, TR, TBE**    Optional Mounting: **TM**

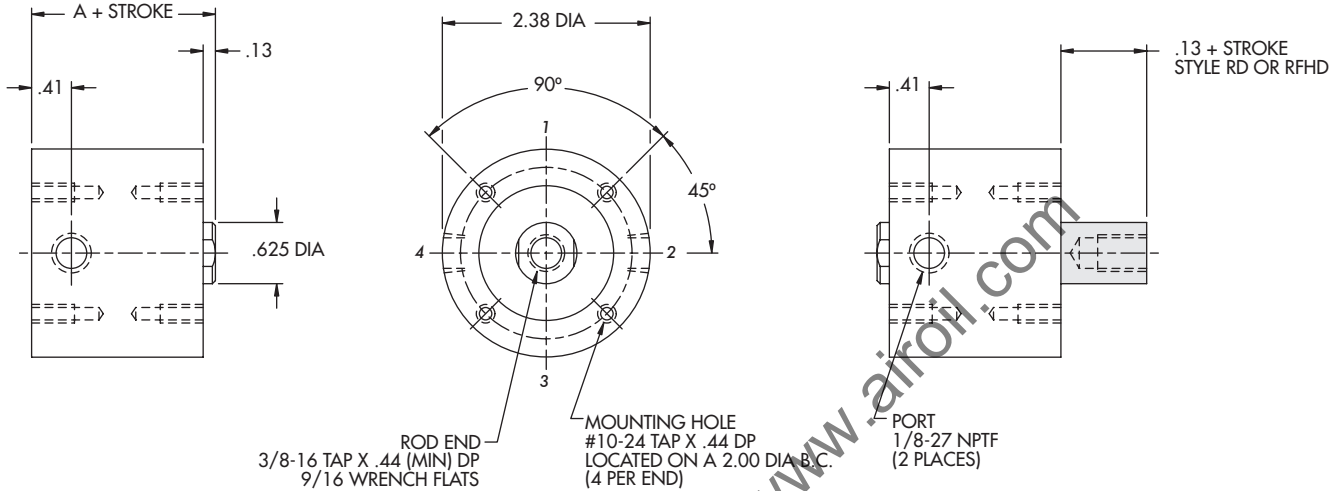

Duty	Part Number		Standard Stroke Length	A
	Single Rod	Double Rod		
Standard	<b>R158x</b> __	<b>RD158x</b> __	7/8 to 6 in 1/8" increments	1.13
Intermediate	<b>RHH158x</b> __		5/8 to 6 in 1/8" increments	1.38
Heavy	<b>RFH158x</b> __	<b>RFHD158x</b> __	3/8 to 6 in 1/8" increments	1.63

Standard Mounting: **TF**    Optional Mounting: **TR, TBE, TM**  
 Information same as above except where noted.

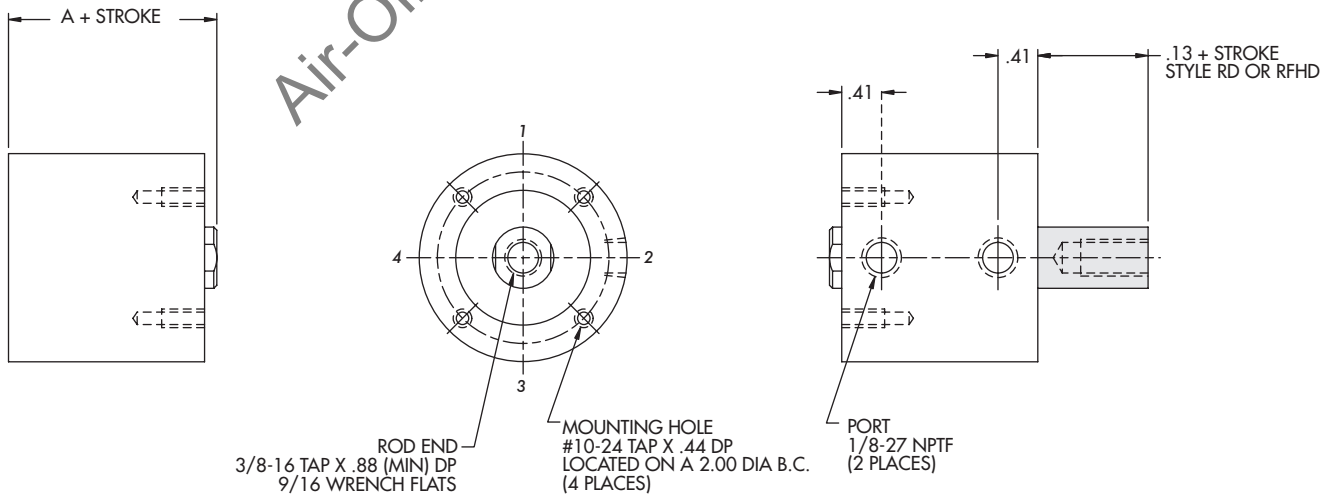



# 1-5/8" Bore Magnetic Piston

THIRD ANGLE PROJECTION

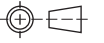

Duty	Part Number		Standard Stroke Length	A
	Single Rod	Double Rod		
Standard	AR158x__	ARD158x__	1/8 to 1/2 in 1/8" increments	1.38
Intermediate	ARHH158x__		1/8, 1/4	1.63

Standard Mounting: **TF, TR, TBE**    Optional Mounting: **TM**

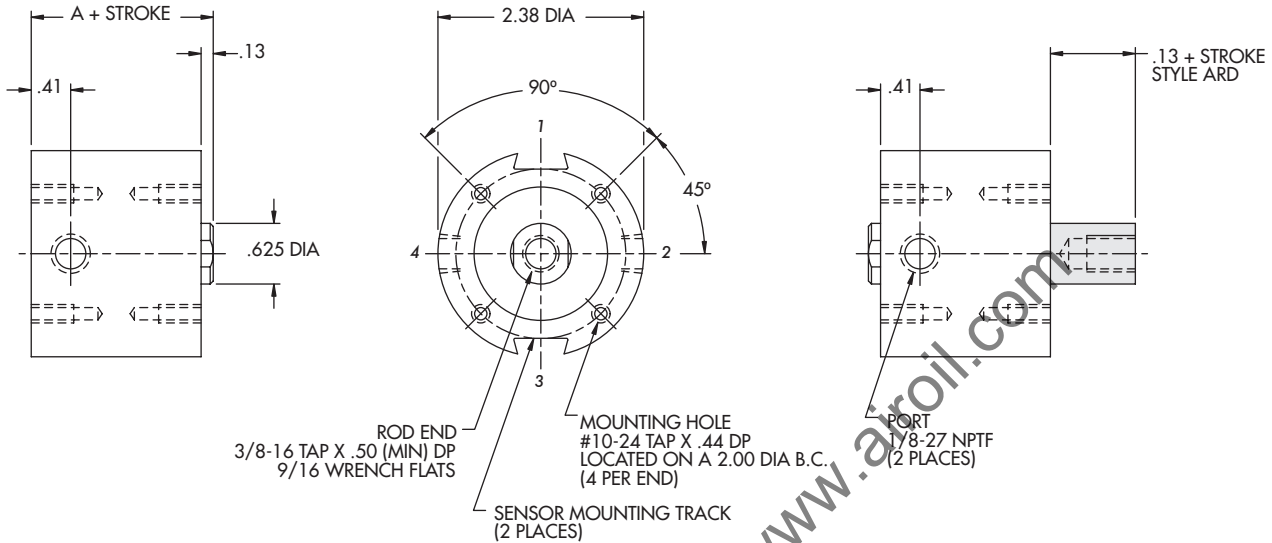

Duty	Part Number		Standard Stroke Length	A
	Single Rod	Double Rod		
Standard	AR158x__	ARD158x__	5/8 to 6 in 1/8" increments	1.38
Intermediate	ARHH158x__		3/8 to 6 in 1/8" increments	1.63
Heavy	ARFH158x__	ARFHD158x__	1/8 to 6 in 1/8" increments	1.88

Standard Mounting: **TF**    Optional Mounting: **TR, TBE, TM**

Information same as above except where noted.

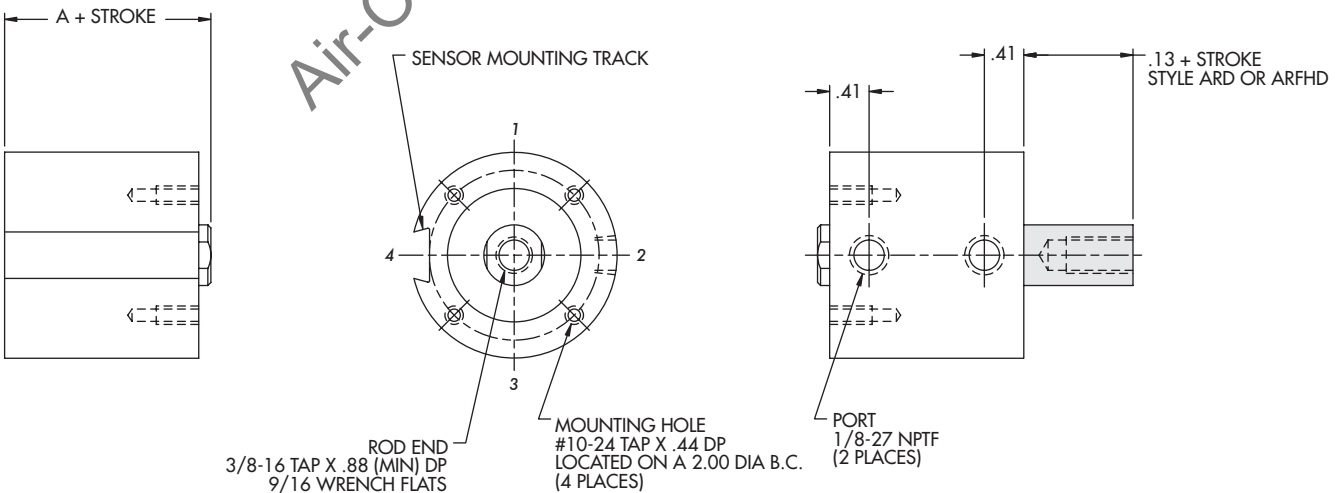

Style "S"



End Mount

# 2" Bore Non Magnetic Piston

THIRD ANGLE PROJECTION

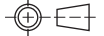

Duty	Part Number		Standard Stroke Length	A
	Single Rod	Double Rod		
Standard	<b>S2x</b> ___	<b>SD2x</b> ___	1/8 to 3/4 in 1/8" increments	1.25
Intermediate	<b>SHH2x</b> ___		1/8 to 1/2 in 1/8" increments	1.50
Heavy	<b>SFH2x</b> ___	<b>SFHD2x</b> ___	1/8, 1/4	1.75

Standard Mounting: **TF, TR, TBE, TM**

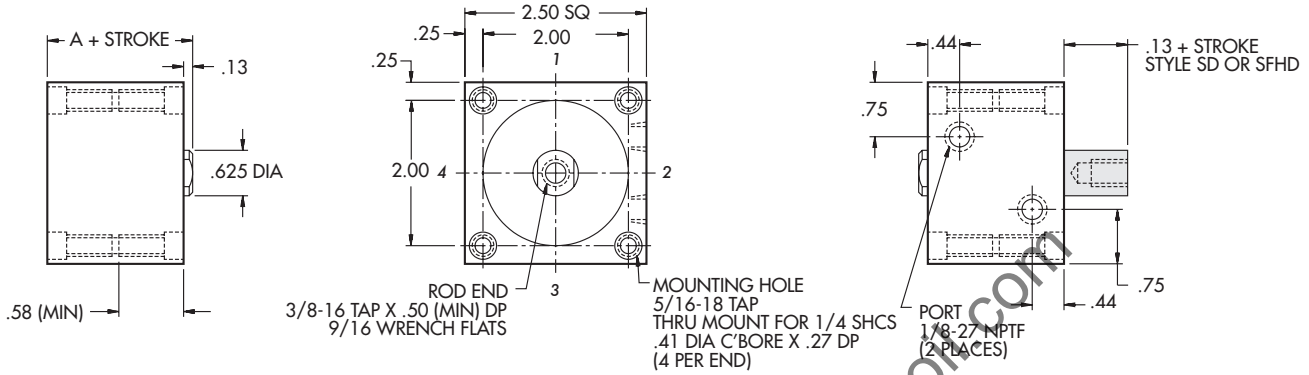

Duty	Part Number		Standard Stroke Length	A
	Single Rod	Double Rod		
Standard	<b>S2x</b> ___	<b>SD2x</b> ___	7/8 to 1-1/2 in 1/8" increments	1.25
Intermediate	<b>SHH2x</b> ___		5/8 to 1-1/4 in 1/8" increments	1.50
Heavy	<b>SFH2x</b> ___	<b>SFHD2x</b> ___	3/8 to 1 in 1/8" increments	1.75

Standard Mounting: **TF, TR, TBE, TM**

Information same as above except where noted.

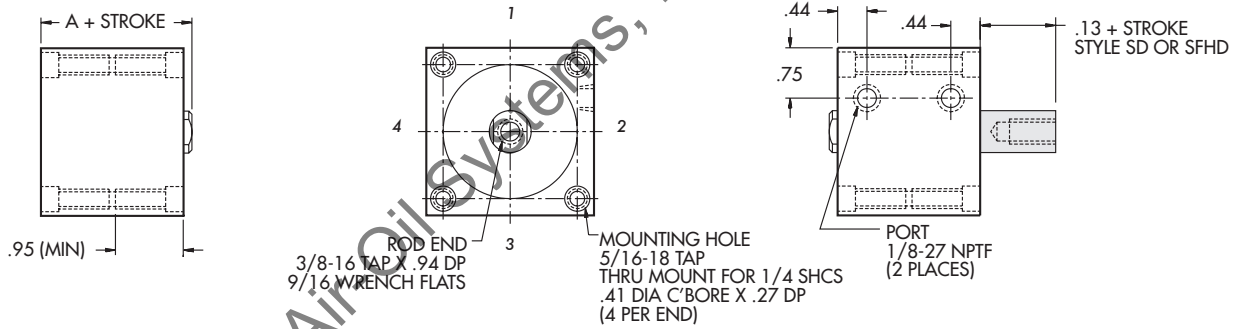

Duty	Part Number		Standard Stroke Length	A
	Single Rod	Double Rod		
Standard	<b>S2x</b> ___	<b>SD2x</b> ___	1-5/8 to 6 in 1/8" increments	1.25
Intermediate	<b>SHH2x</b> ___		1-3/8 to 6 in 1/8" increments	1.50
Heavy	<b>SFH2x</b> ___	<b>SFHD2x</b> ___	1-1/8 to 6 in 1/8" increments	1.75

Standard Mounting: **TF** Optional Mounting: **TR, TBE, TM**

Information same as above except where noted.

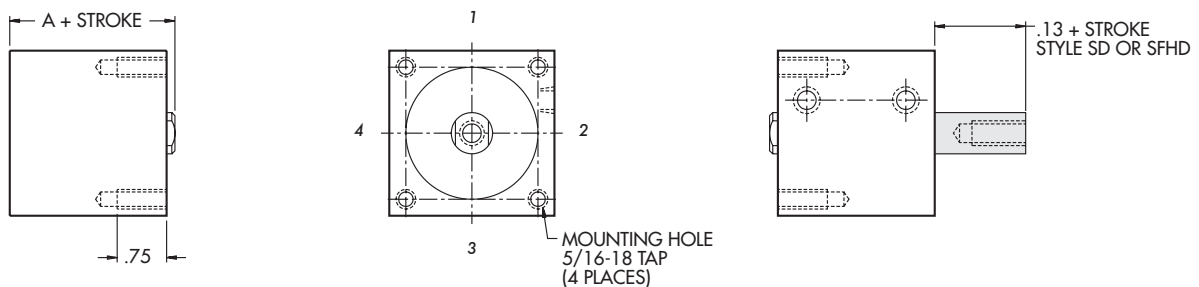



# 2" Bore Magnetic Piston

THIRD ANGLE PROJECTION



Duty	Part Number		Standard Stroke Length	A
	Single Rod	Double Rod		
Standard	<b>AS2x</b> __	<b>ASD2x</b> __	1/8 to 1/2 in 1/8" increments	1.50
Intermediate	<b>ASHH2x</b> __		1/8, 1/4	1.75

Standard Mounting: **TF, TR, TBE, TM**

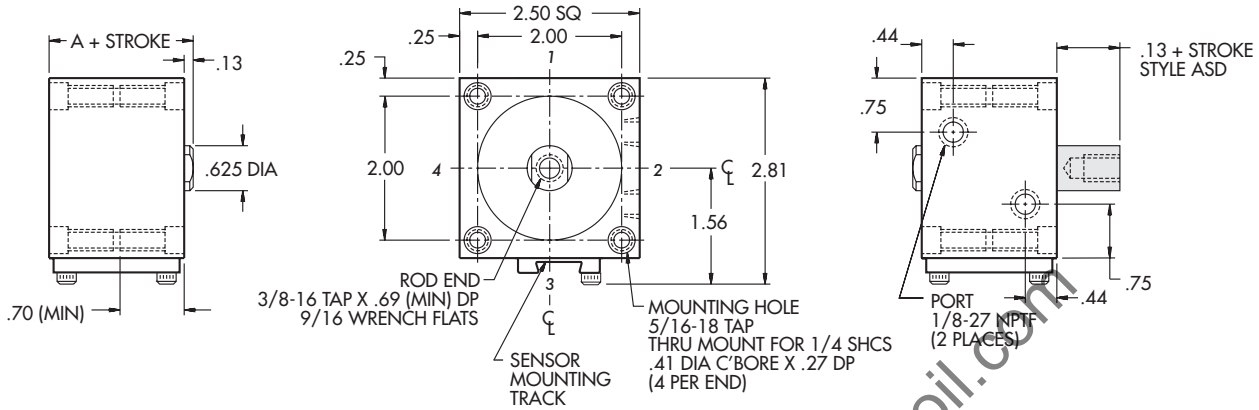

Duty	Part Number		Standard Stroke Length	A
	Single Rod	Double Rod		
Standard	<b>AS2x</b> __	<b>ASD2x</b> __	5/8 to 1-1/4 in 1/8" increments	1.50
Intermediate	<b>ASHH2x</b> __		3/8 to 1 in 1/8" increments	1.75
Heavy	<b>ASFH2x</b> __	<b>ASFHD2x</b> __	1/8 to 3/4 in 1/8" increments	2.00

Standard Mounting: **TF, TR, TBE, TM**

Information same as above except where noted.

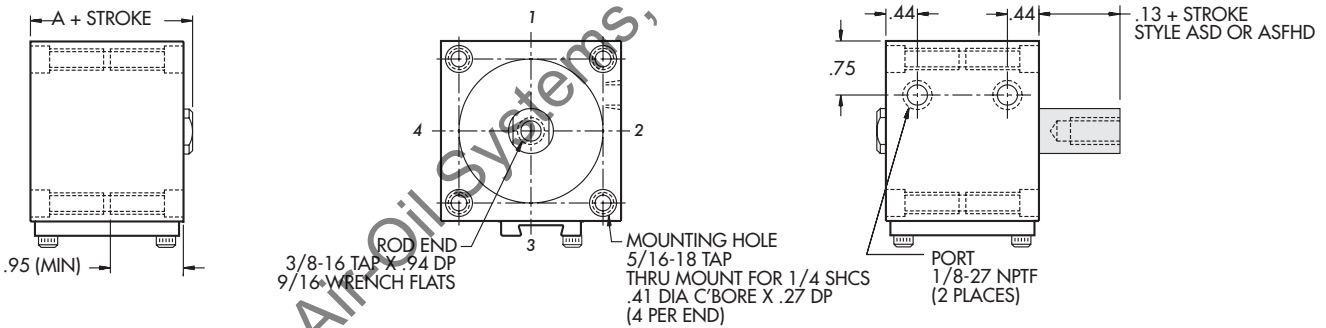

Duty	Part Number		Standard Stroke Length	A
	Single Rod	Double Rod		
Standard	<b>AS2x</b> __	<b>ASD2x</b> __	1-3/8 to 6 in 1/8" increments	1.50
Intermediate	<b>ASHH2x</b> __		1-1/8 to 6 in 1/8" increments	1.75
Heavy	<b>ASFH2x</b> __	<b>ASFHD2x</b> __	7/8 to 6 in 1/8" increments	2.00

Standard Mounting: **TF** Optional Mounting: **TR, TBE, TM**

Information same as above except where noted.

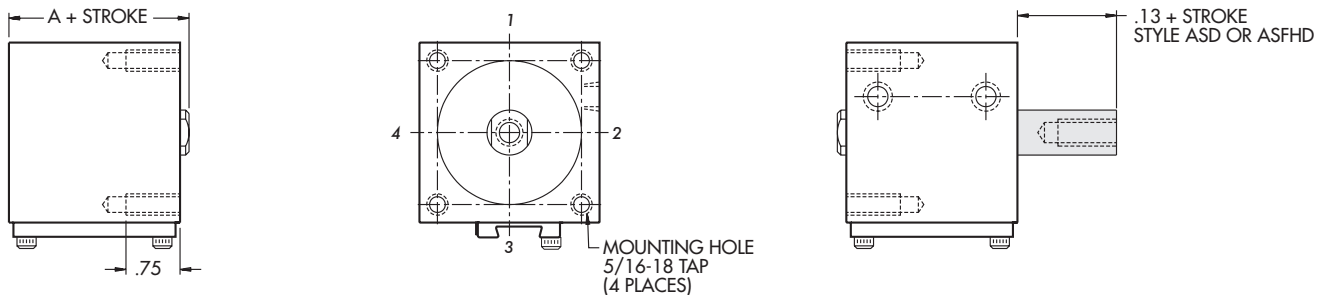

Style "B"



Side Mount

# 2" Bore Non Magnetic Piston

THIRD ANGLE PROJECTION

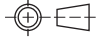

Duty	Part Number		Standard Stroke Length	A
	Single Rod	Double Rod		
Standard	<b>B2x</b> __	<b>BD2x</b> __	1/8 to 3/4 in 1/8" increments	1.25
Intermediate	<b>BHH2x</b> __		1/8 to 1/2 in 1/8" increments	1.50
Heavy	<b>BFH2x</b> __	<b>BFHD2x</b> __	1/8, 1/4	1.75

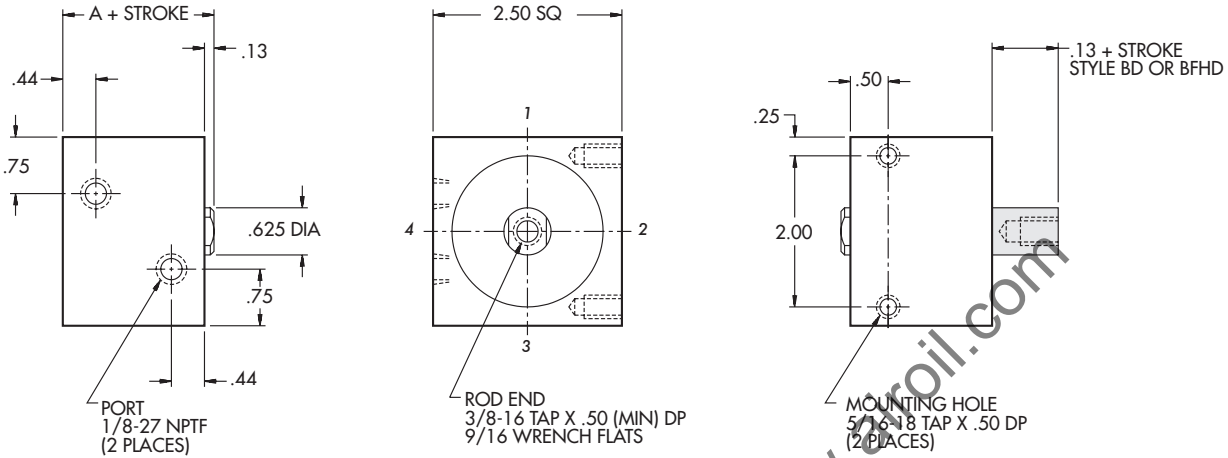

Duty	Part Number		Standard Stroke Length	A
	Single Rod	Double Rod		
Standard	<b>B2x</b> __	<b>BD2x</b> __	7/8 to 6 in 1/8" increments	1.25
Intermediate	<b>BHH2x</b> __		5/8 to 6 in 1/8" increments	1.50
Heavy	<b>BFH2x</b> __	<b>BFHD2x</b> __	3/8 to 6 in 1/8" increments	1.75

Information same as above except where noted.

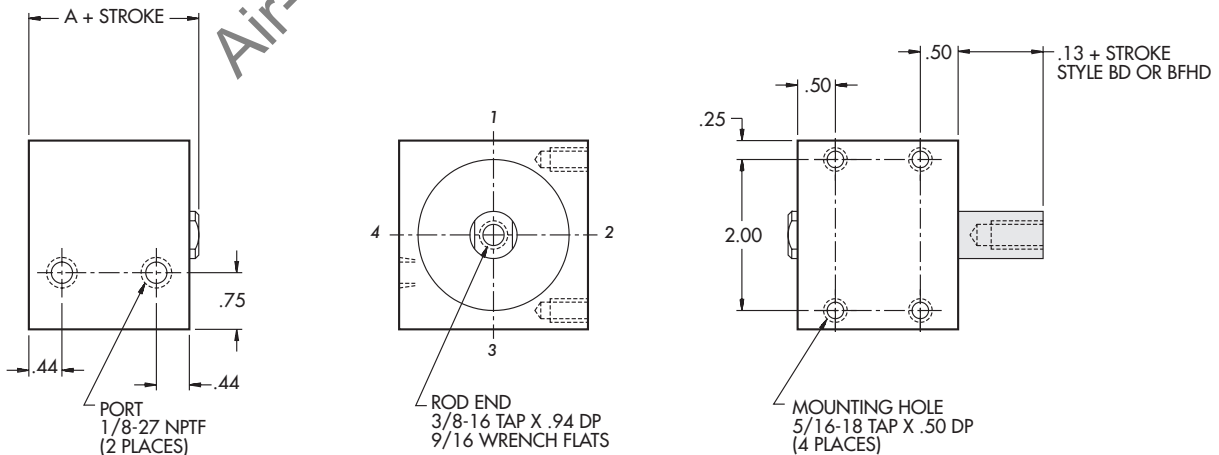





# 2" Bore Magnetic Piston

THIRD ANGLE PROJECTION



Duty	Part Number		Standard Stroke Length	A
	Single Rod	Double Rod		
Standard	AB2x__	ABD2x__	1/8 to 1/2 in 1/8" increments	1.50
Intermediate	ABHH2x__		1/8, 1/4	1.75

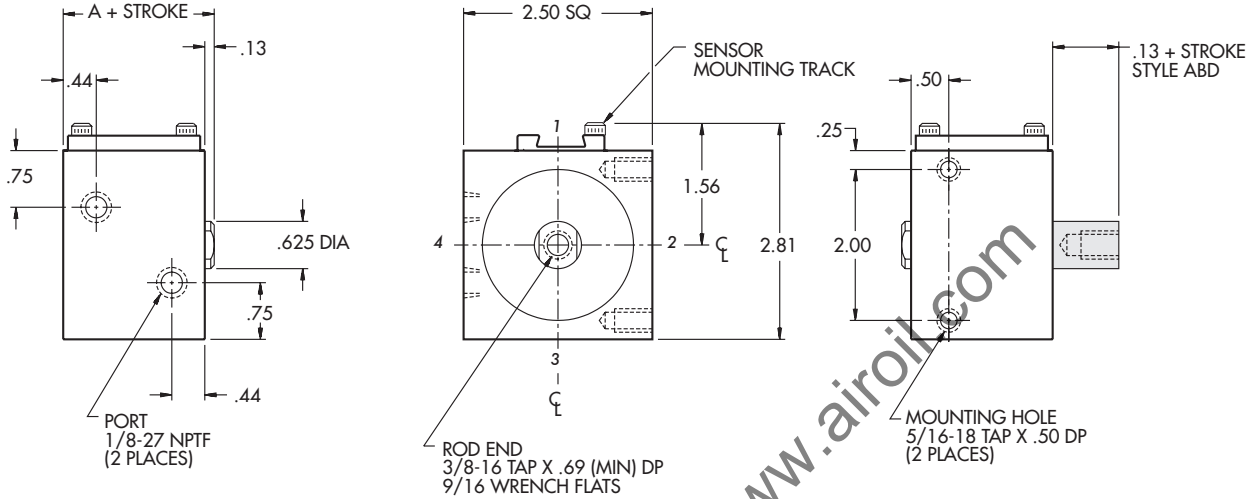

Duty	Part Number		Standard Stroke Length	A
	Single Rod	Double Rod		
Standard	AB2x__	ABD2x__	5/8 to 6 in 1/8" increments	1.50
Intermediate	ABHH2x__		3/8 to 6 in 1/8" increments	1.75
Heavy	ABFH2x__	ABFHD2x__	1/8 to 6 in 1/8" increments	2.00

Information same as above except where noted.

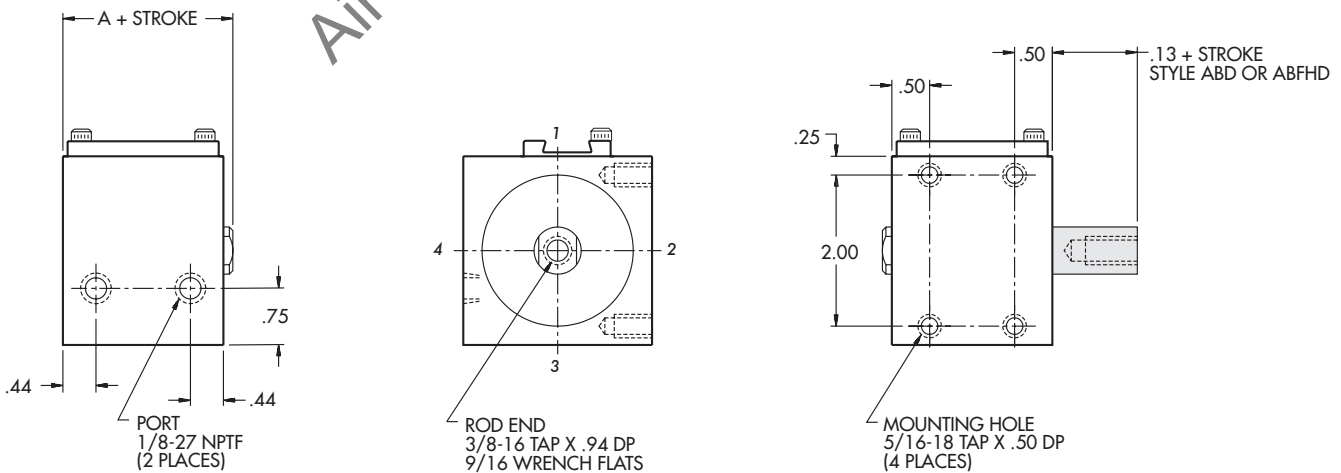



# 2" Bore Non Magnetic Piston

Duty	Part Number		Standard Stroke Length	A
	Single Rod	Double Rod		
Standard	<b>R2x</b> __	<b>RD2x</b> __	1/8 to 3/4 in 1/8" increments	1.25
Intermediate	<b>RHH2x</b> __		1/8 to 1/2 in 1/8" increments	1.50
Heavy	<b>RFH2x</b> __	<b>RFHD2x</b> __	1/8, 1/4	1.75

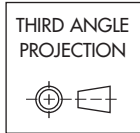

Standard Mounting: **TF, TR, TBE**    Optional Mounting: **TM**

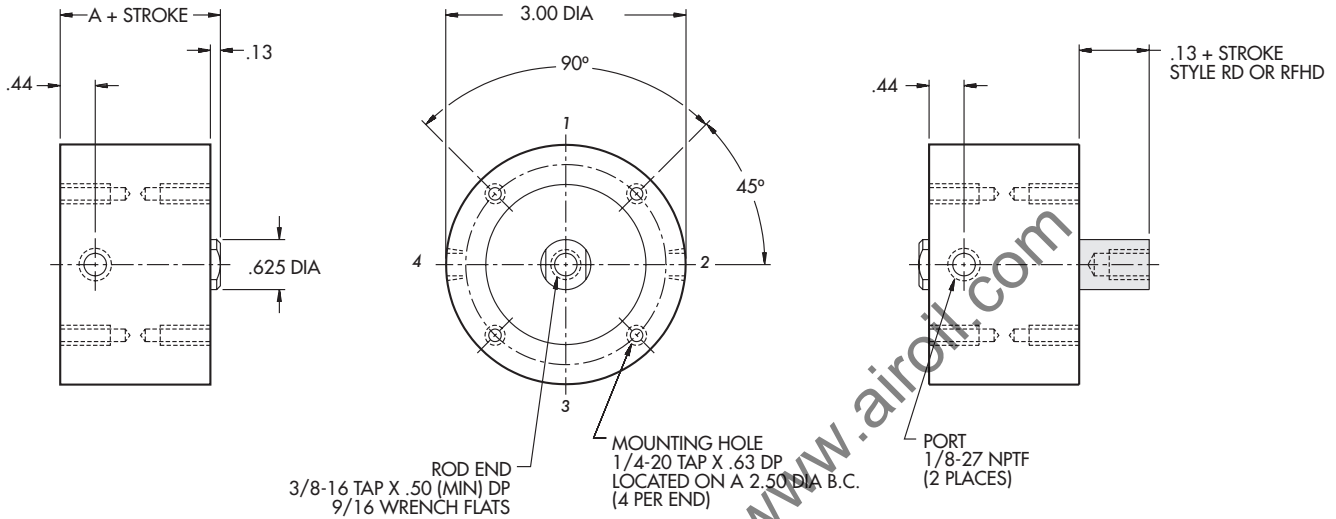

Duty	Part Number		Standard Stroke Length	A
	Single Rod	Double Rod		
Standard	<b>R2x</b> __	<b>RD2x</b> __	7/8 to 6 in 1/8" increments	1.25
Intermediate	<b>RHH2x</b> __		3/8 to 6 in 1/8" increments	1.50
Heavy	<b>RFH2x</b> __	<b>RFHD2x</b> __	3/8 to 6 in 1/8" increments	1.75

Standard Mounting: **TF**    Optional Mounting: **TR, TBE, TM**

Information same as above except where noted.

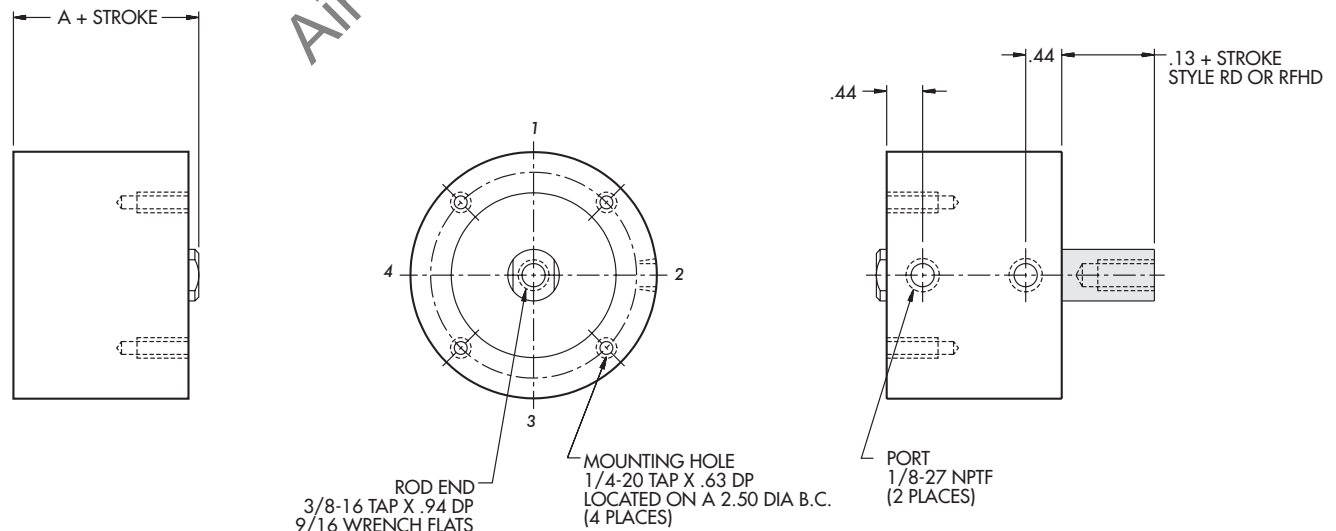

# 2" Bore Magnetic Piston

Style "AR"



End Mount

THIRD ANGLE PROJECTION



Duty	Part Number		Standard Stroke Length	A
	Single Rod	Double Rod		
Standard	AR2x__	ARD2x__	1/8 to 1/2 in 1/8" increments	1.50
Intermediate	ARHH2x__		1/8, 1/4	1.75

Standard Mounting: **TF, TR, TBE**    Optional Mounting: **TM**

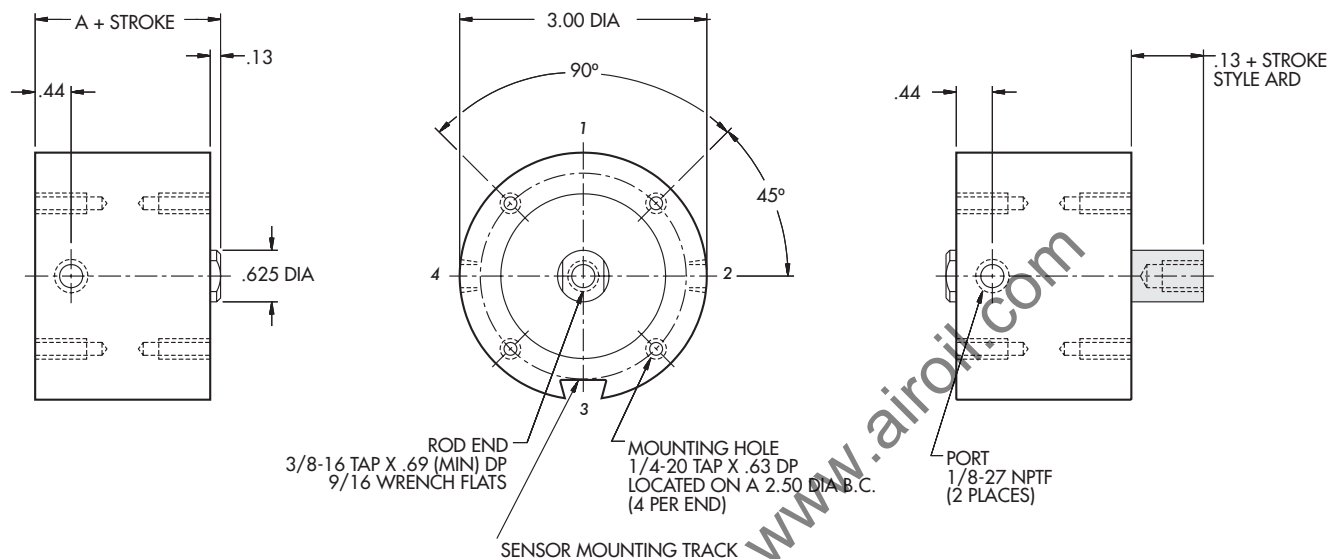

Duty	Part Number		Standard Stroke Length	A
	Single Rod	Double Rod		
Standard	AR2x__	ARD2x__	5/8 to 6 in 1/8" increments	1.50
Intermediate	ARHH2x__		3/8 to 6 in 1/8" increments	1.75
Heavy	ARFH2x__	ARFHD2x__	1/8 to 6 in 1/8" increments	2.00

Standard Mounting: **TF**    Optional Mounting: **TR, TBE, TM**

Information same as above except where noted.

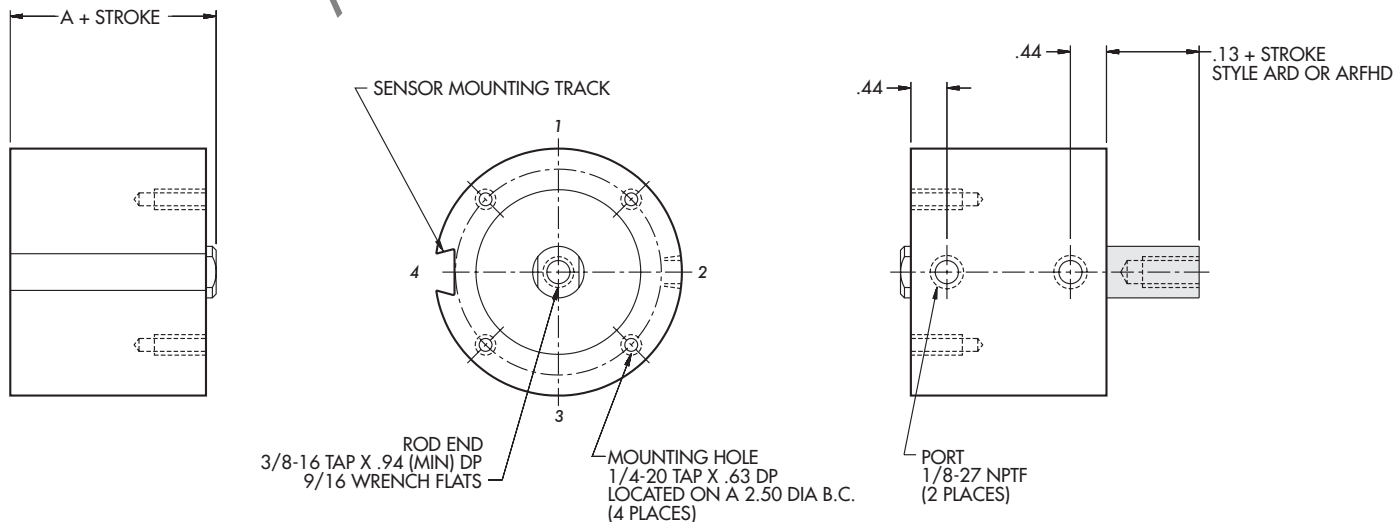



# 2-1/2" Bore Non Magnetic Piston

THIRD ANGLE PROJECTION

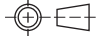

Duty	Part Number		Standard Stroke Length	A
	Single Rod	Double Rod		
Standard	<b>S212x</b> __	<b>SD212x</b> __	1/8 to 3/4 in 1/8" increments	1.38
Intermediate	<b>SHH212x</b> __		1/8 to 1/2 in 1/8" increments	1.63
Heavy	<b>SFH212x</b> __	<b>SFHD212x</b> __	1/8, 1/4	1.88

Standard Mounting: **TF, TR, TBE, TM**

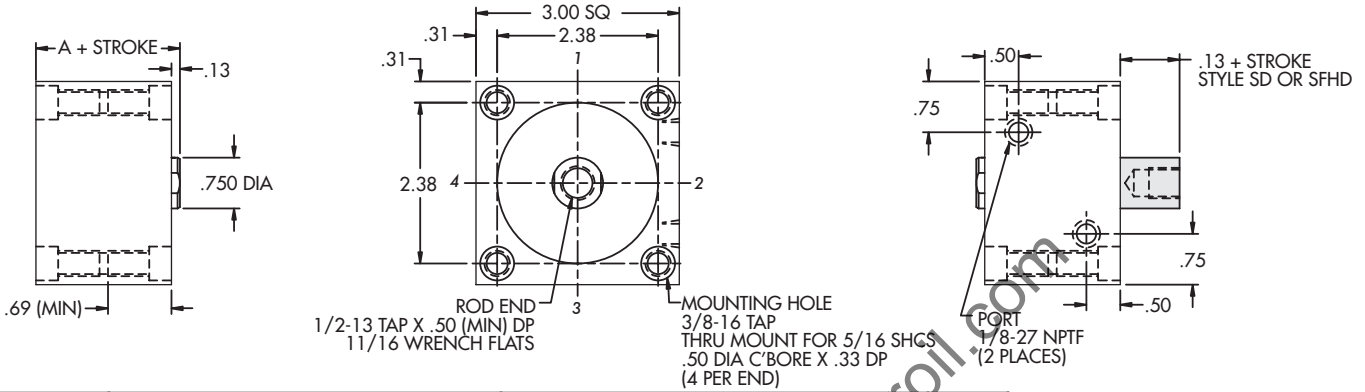

Duty	Part Number		Standard Stroke Length	A
	Single Rod	Double Rod		
Standard	<b>S212x</b> __	<b>SD212x</b> __	7/8 to 1-1/2 in 1/8" increments	1.38
Intermediate	<b>SHH212x</b> __		5/8 to 1-1/4 in 1/8" increments	1.63
Heavy	<b>SFH212x</b> __	<b>SFHD212x</b> __	3/8 to 1 in 1/8" increments	1.88

Standard Mounting: **TF, TR, TBE, TM**

Information same as above except where noted.

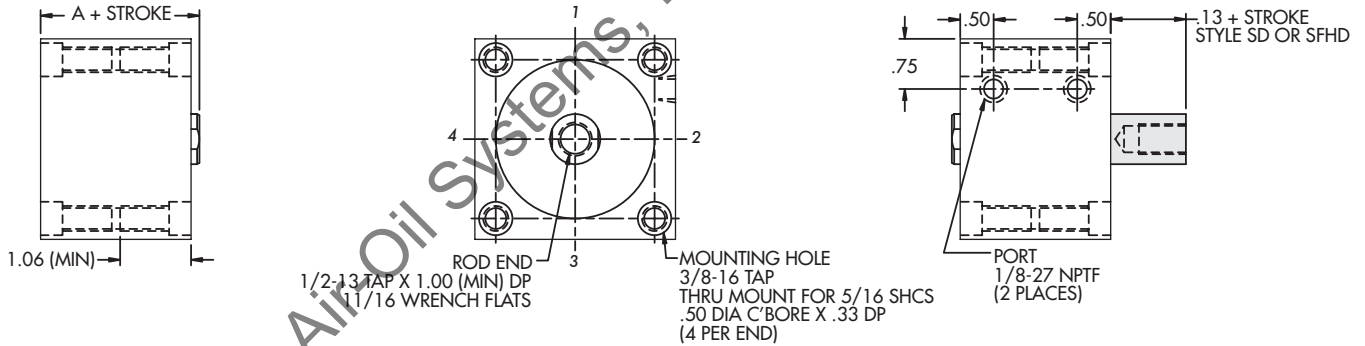

Duty	Part Number		Standard Stroke Length	A
	Single Rod	Double Rod		
Standard	<b>S212x</b> __	<b>SD212x</b> __	1-5/8 to 6 in 1/8" increments	1.38
Intermediate	<b>SHH212x</b> __		1-3/8 to 6 in 1/8" increments	1.63
Heavy	<b>SFH212x</b> __	<b>SFHD212x</b> __	1-1/8 to 6 in 1/8" increments	1.88

Standard Mounting: **TF**      Optional Mounting: **TR, TBE, TM**

Information same as above except where noted.

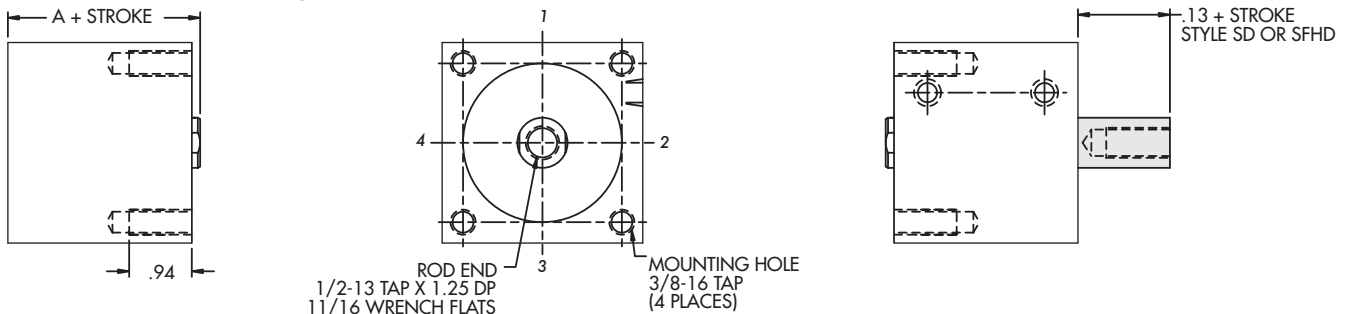



# 2-1/2" Bore Magnetic Piston

THIRD ANGLE PROJECTION



Duty	Part Number		Standard Stroke Length	A
	Single Rod	Double Rod		
Standard	<b>AS212x</b> __	<b>ASD212x</b> __	1/8 to 1/2 in 1/8" increments	1.63
Intermediate	<b>ASHH212x</b> __		1/8, 1/4	1.88

Standard Mounting: **TF, TR, TBE, TM**

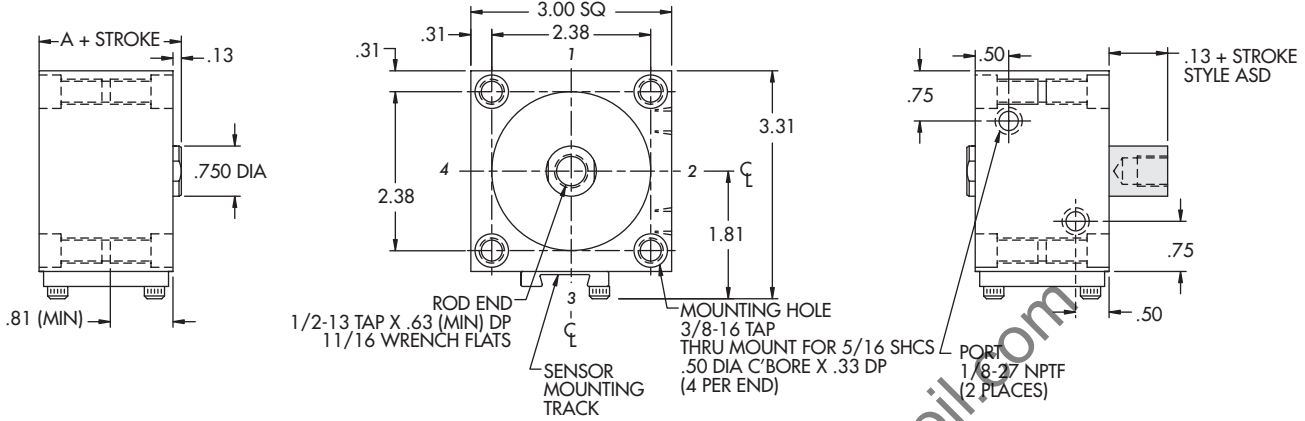

Duty	Part Number		Standard Stroke Length	A
	Single Rod	Double Rod		
Standard	<b>AS212x</b> __	<b>ASD212x</b> __	5/8 to 1-1/4 in 1/8" increments	1.63
Intermediate	<b>ASHH212x</b> __		3/8 to 1 in 1/8" increments	1.88
Heavy	<b>ASFH212x</b> __	<b>ASFHD212x</b> __	1/8 to 3/4 in 1/8" increments	2.13

Standard Mounting: **TF, TR, TBE, TM**

Information same as above except where noted.

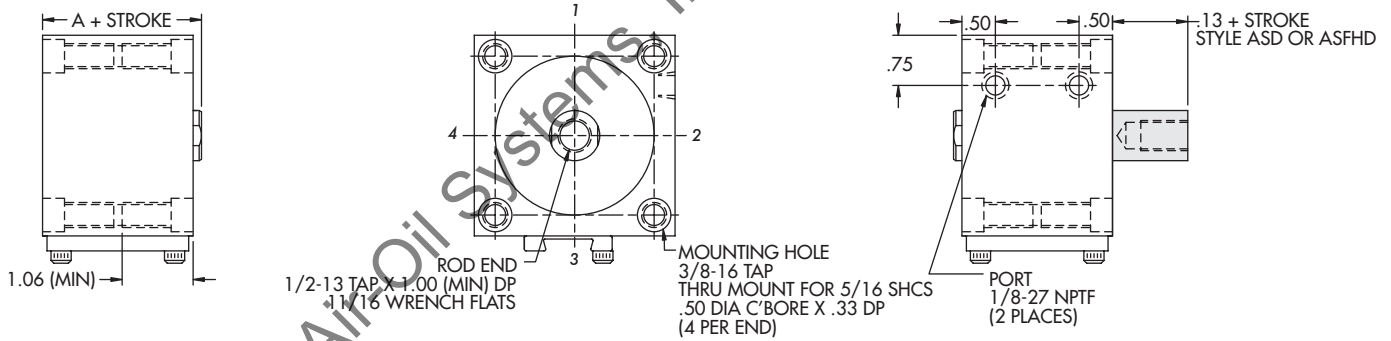

Duty	Part Number		Standard Stroke Length	A
	Single Rod	Double Rod		
Standard	<b>AS212x</b> __	<b>ASD212x</b> __	1-3/8 to 6 in 1/8" increments	1.63
Intermediate	<b>ASHH212x</b> __		1-1/8 to 6 in 1/8" increments	1.88
Heavy	<b>ASFH212x</b> __	<b>ASFHD212x</b> __	7/8 to 6 in 1/8" increments	2.13

Standard Mounting: **TF** Optional Mounting: **TR, TBE, TM**

Information same as above except where noted.

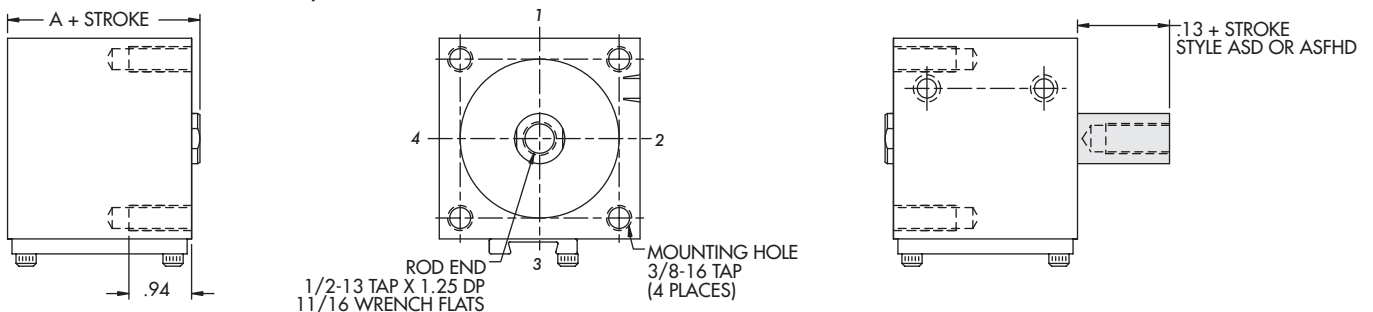

Style "B"



Side Mount

# 2-1/2" Bore Non Magnetic Piston

Duty	Part Number		Standard Stroke Length	A
	Single Rod	Double Rod		
Standard	<b>B212x</b> __	<b>BD212x</b> __	1/8 to 3/4 in 1/8" increments	1.38
Intermediate	<b>BHH212x</b> __		1/8 to 1/2 in 1/8" increments	1.63
Heavy	<b>BFH212x</b> __	<b>BFHD212x</b> __	1/8, 1/4	1.88



Optional Porting: **1/4-18 NPTF**

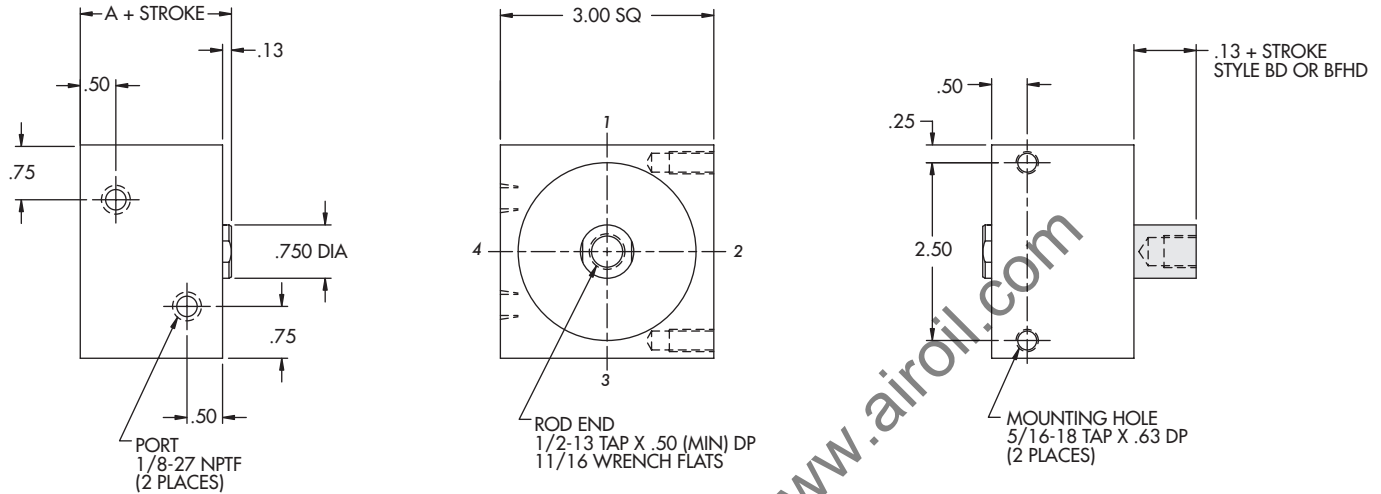

Duty	Part Number		Standard Stroke Length	A
	Single Rod	Double Rod		
Standard	<b>B212x</b> __	<b>BD212x</b> __	7/8 to 6 in 1/8" increments	1.38
Intermediate	<b>BHH212x</b> __		5/8 to 6 in 1/8" increments	1.63
Heavy	<b>BFH212x</b> __	<b>BFHD212x</b> __	3/8 to 6 in 1/8" increments	1.88

Optional Porting: **1/4-18 NPTF**

Information same as above except where noted.

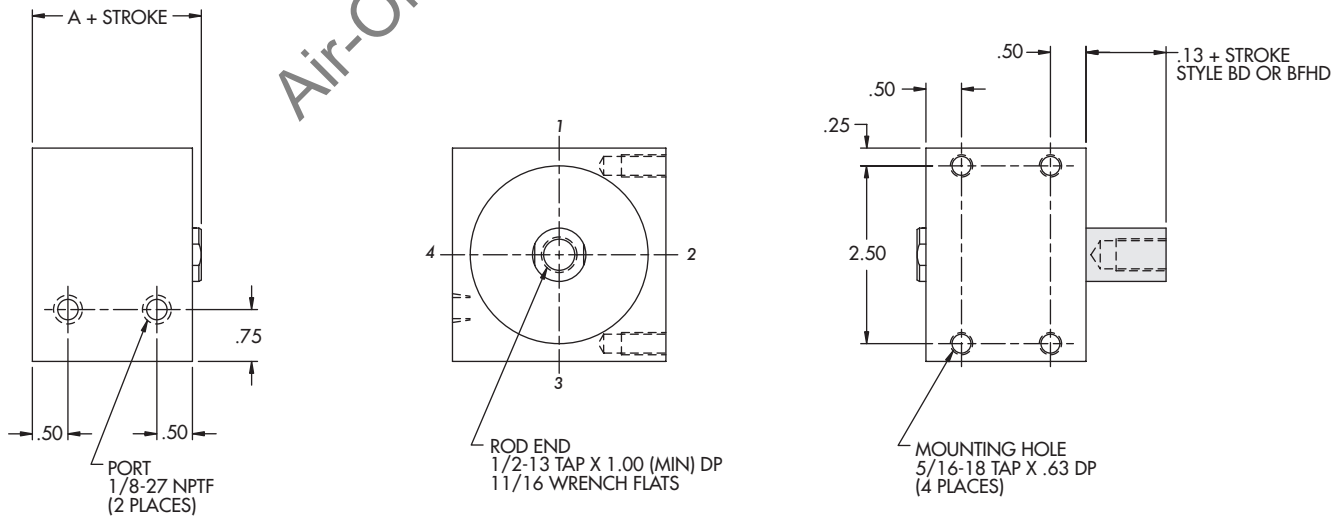



# 2-1/2" Bore Magnetic Piston

THIRD ANGLE PROJECTION

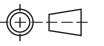

Duty	Part Number		Standard Stroke Length	A
	Single Rod	Double Rod		
Standard	<b>AB212x__</b>	<b>ABD212x__</b>	1/8 to 1/2 in 1/8" increments	1.63
Intermediate	<b>ABHH212x__</b>		1/8, 1/4	1.88

Optional Porting: **1/4-18 NPTF**

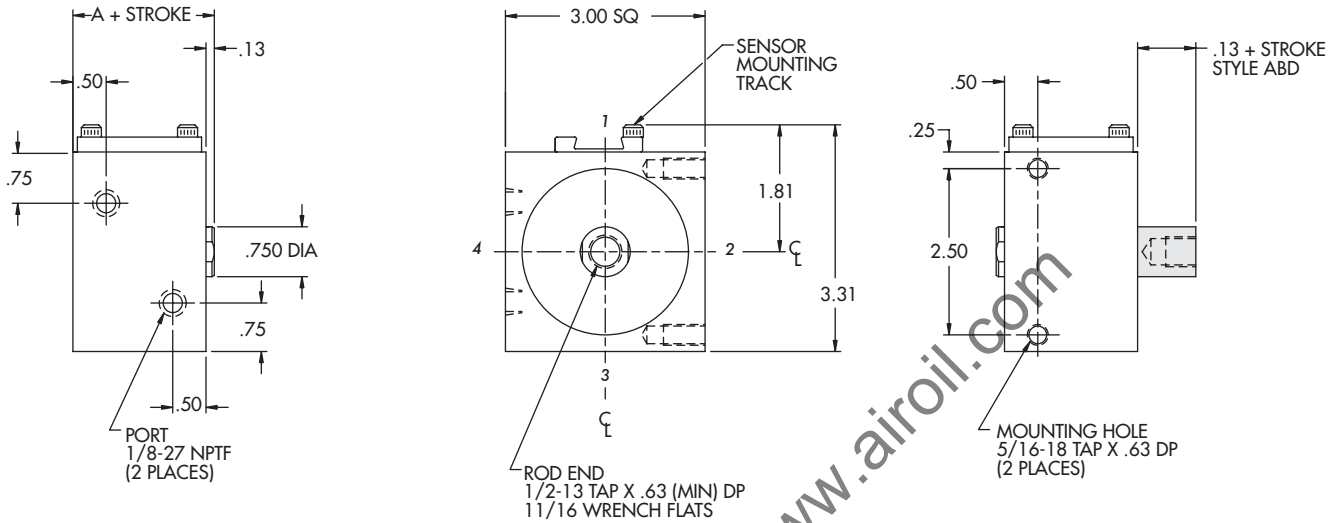

Duty	Part Number		Standard Stroke Length	A
	Single Rod	Double Rod		
Standard	<b>AB212x__</b>	<b>ABD212x__</b>	5/8 to 6 in 1/8" increments	1.63
Intermediate	<b>ABHH212x__</b>		3/8 to 6 in 1/8" increments	1.88
Heavy	<b>ABFH212x__</b>	<b>ABFHD212x__</b>	1/8 to 6 in 1/8" increments	2.13

Optional Porting: **1/4-18 NPTF**

Information same as above except where noted.

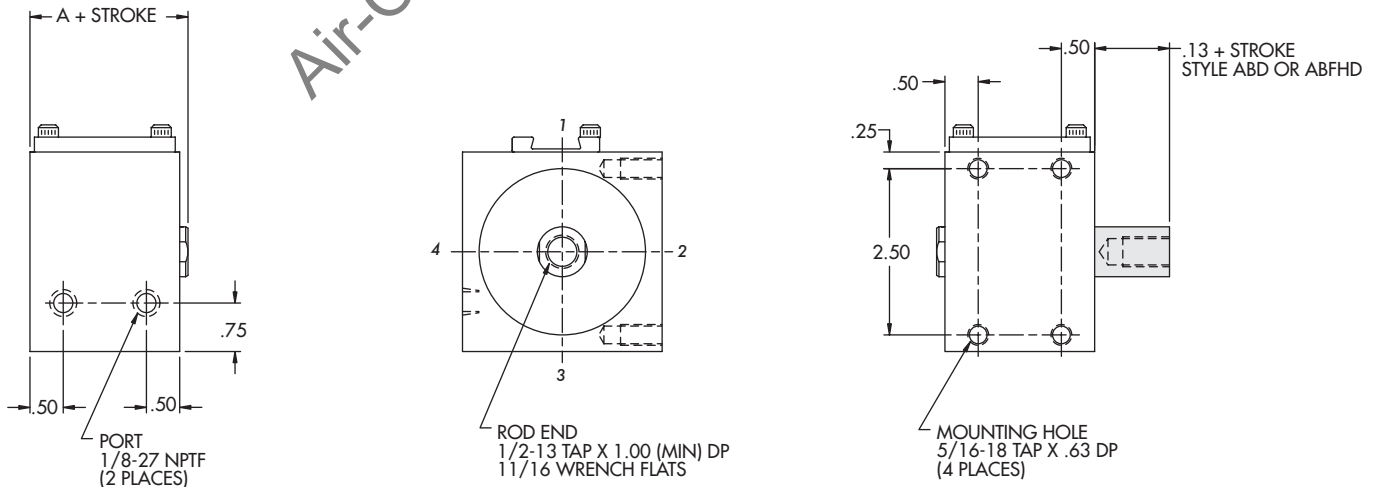



# 2-1/2" Bore Non Magnetic Piston



Duty	Part Number		Standard Stroke Length	A
	Single Rod	Double Rod		
Standard	<b>R212x</b> __	<b>RD212x</b> __	1/8 to 3/4 in 1/8" increments	1.38
Intermediate	<b>RHH212x</b> __		1/8 to 1/2 in 1/8" increments	1.63
Heavy	<b>RFH212x</b> __	<b>RFHD212x</b> __	1/8, 1/4	1.88

Standard Mounting: **TF, TR, TBE**    Optional Mounting: **TM**    Optional Porting: **1/4-18 NPTF**

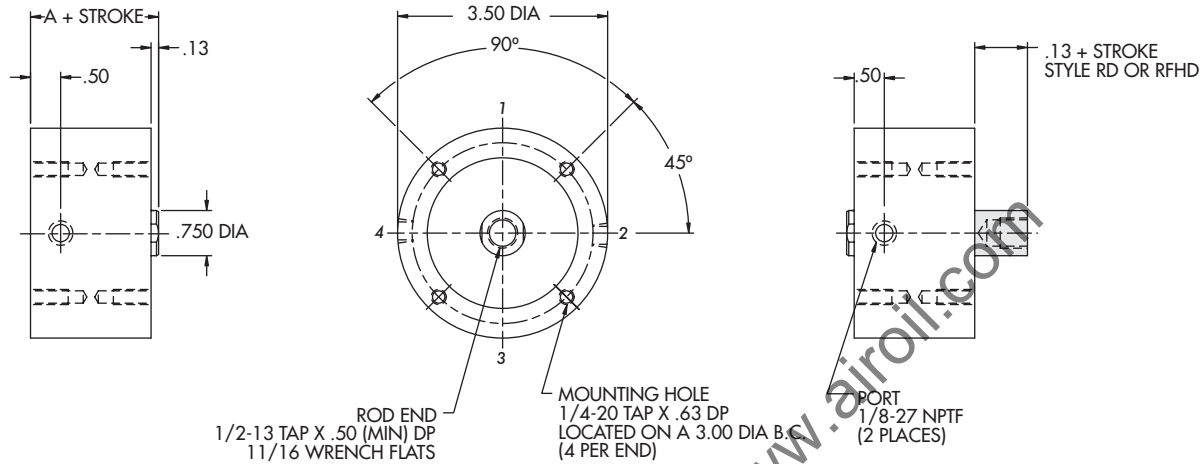

Duty	Part Number		Standard Stroke Length	A
	Single Rod	Double Rod		
Standard	<b>R212x</b> __	<b>RD212x</b> __	1/8 to 6 in 1/8" increments	1.38
Intermediate	<b>RHH212x</b> __		5/8 to 6 in 1/8" increments	1.63
Heavy	<b>RFH212x</b> __	<b>RFHD212x</b> __	3/8 to 6 in 1/8" increments	1.88

Standard Mounting: **TF**    Optional Mounting: **TR, TBE, TM**    Optional Porting: **1/4-18 NPTF**  
 Information same as above except where noted.

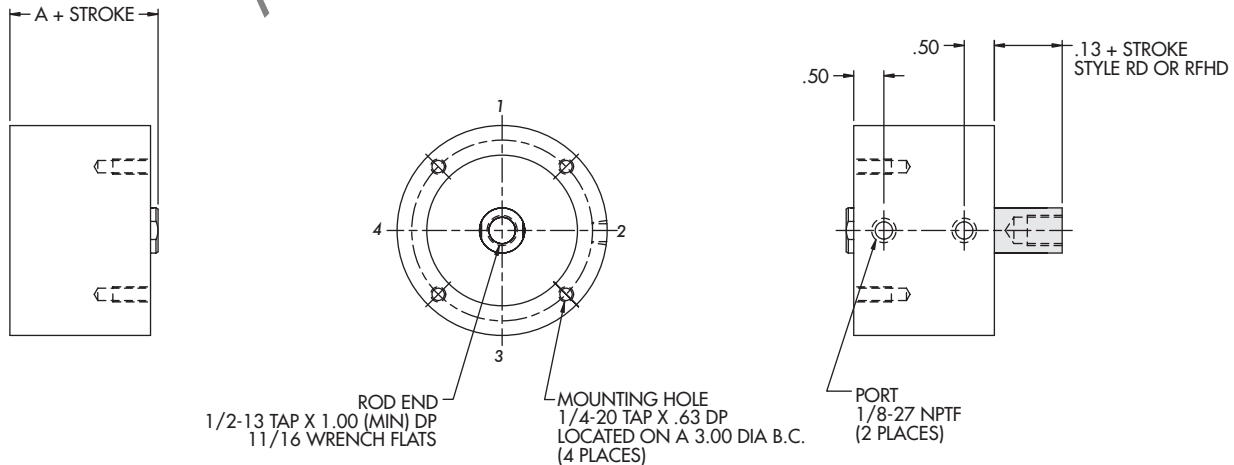





# 2-1/2" Bore Magnetic Piston

THIRD ANGLE PROJECTION

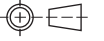

Duty	Part Number		Standard Stroke Length	A
	Single Rod	Double Rod		
Standard	AR212x__	ARD212x__	1/8 to 1/2 in 1/8" increments	1.63
Intermediate	ARHH212x__		1/8, 1/4	1.88

Standard Mounting: **TF, TR, TBE**    Optional Mounting: **TM**    Optional Porting: **1/4-18 NPTF**

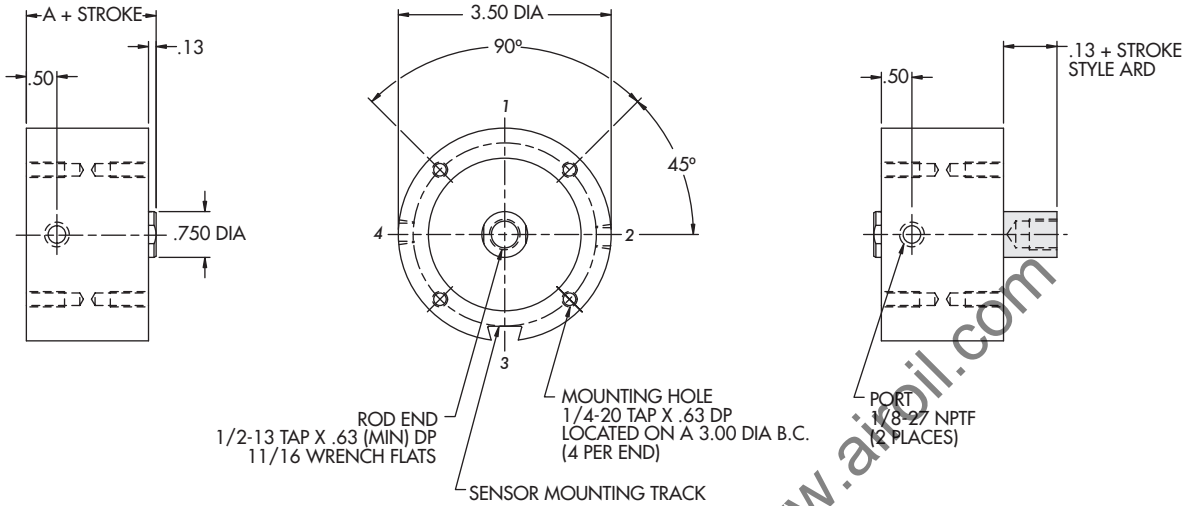

Duty	Part Number		Standard Stroke Length	A
	Single Rod	Double Rod		
Standard	AR212x__	ARD212x__	5/8 to 6 in 1/8" increments	1.63
Intermediate	ARHH212x__		3/8 to 6 in 1/8" increments	1.88
Heavy	ARFH212x__	ARFHD212x__	1/8 to 6 in 1/8" increments	2.13

Standard Mounting: **TF**    Optional Mounting: **TR, TBE, TM**    Optional Porting: **1/4-18 NPTF**  
 Information same as above except where noted.

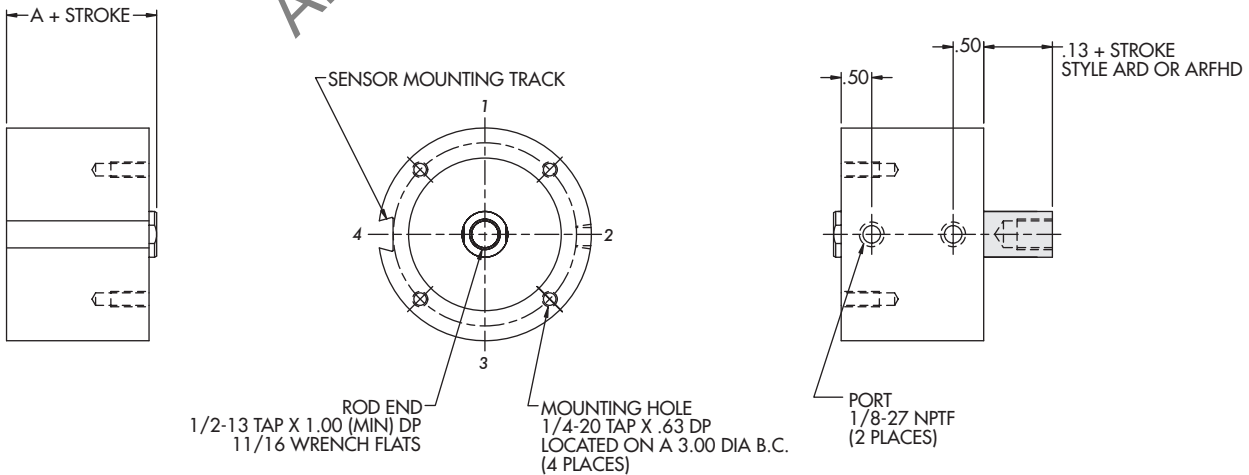



# 3" Bore Non Magnetic Piston

THIRD ANGLE PROJECTION

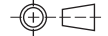

Duty	Part Number		Standard Stroke Length	A
	Single Rod	Double Rod		
Standard	<b>S3x</b> __	<b>SD3x</b> __	1/8 to 3/4 in 1/8" increments	1.63
Intermediate	<b>SHH3x</b> __		1/8 to 1/2 in 1/8" increments	1.88
Heavy	<b>SFH3x</b> __	<b>SFHD3x</b> __	1/8, 1/4	2.13

Standard Mounting: **TF, TR, TBE, TM**    Optional Porting: **1/4-18 NPTF**

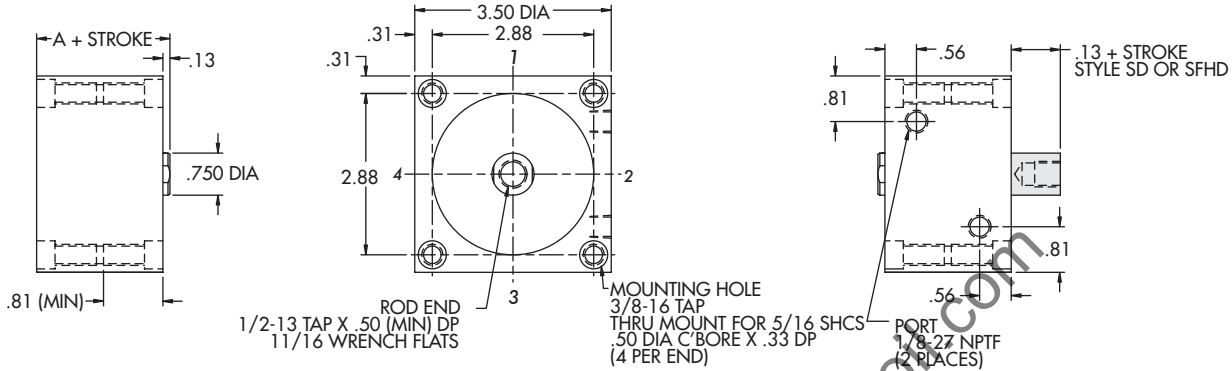

Duty	Part Number		Standard Stroke Length	A
	Single Rod	Double Rod		
Standard	<b>S3x</b> __	<b>SD3x</b> __	7/8 to 1-1/2 in 1/8" increments	1.63
Intermediate	<b>SHH3x</b> __		5/8 to 1-1/4 in 1/8" increments	1.88
Heavy	<b>SFH3x</b> __	<b>SFHD3x</b> __	3/8 to 1 in 1/8" increments	2.13

Standard Mounting: **TF, TR, TBE, TM**    Optional Porting: **1/4-18 NPTF**

Information same as above except where noted.

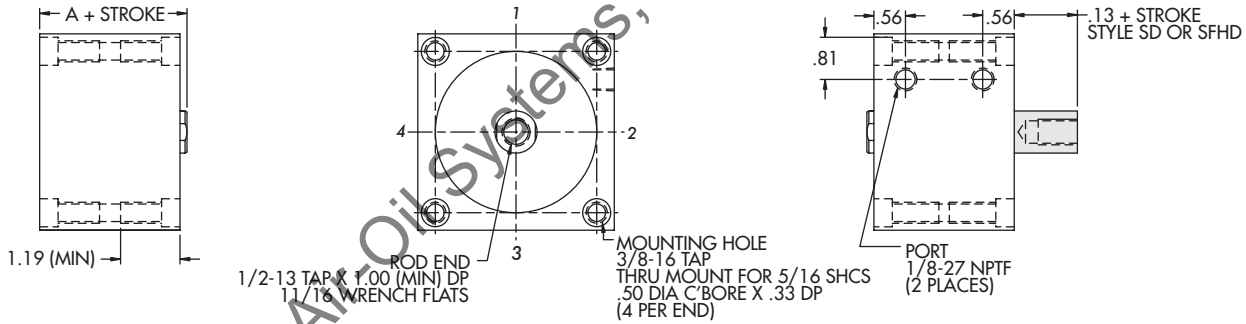

Duty	Part Number		Standard Stroke Length	A
	Single Rod	Double Rod		
Standard	<b>S3x</b> __	<b>SD3x</b> __	1-5/8 to 6 in 1/8" increments	1.63
Intermediate	<b>SHH3x</b> __		1-3/8 to 6 in 1/8" increments	1.88
Heavy	<b>SFH3x</b> __	<b>SFHD3x</b> __	1-1/8 to 6 in 1/8" increments	2.13

Standard Mounting: **TF**    Optional Mounting: **TR, TBE, TM**    Optional Porting: **1/4-18 NPTF**

Information same as above except where noted.

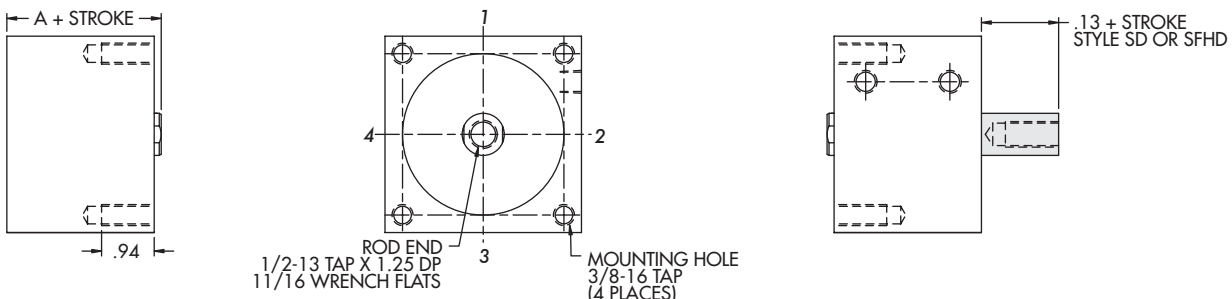



# 3" Bore Magnetic Piston

THIRD ANGLE PROJECTION



Duty	Part Number		Standard Stroke Length	A
	Single Rod	Double Rod		
Standard	<b>AS3x</b> ___	<b>ASD3x</b> ___	1/8 to 1/2 in 1/8" increments	1.88
Intermediate	<b>ASHH3x</b> ___		1/8, 1/4	2.13

Standard Mounting: **TF, TR, TBE, TM**    Optional Porting: **1/4-18 NPTF**

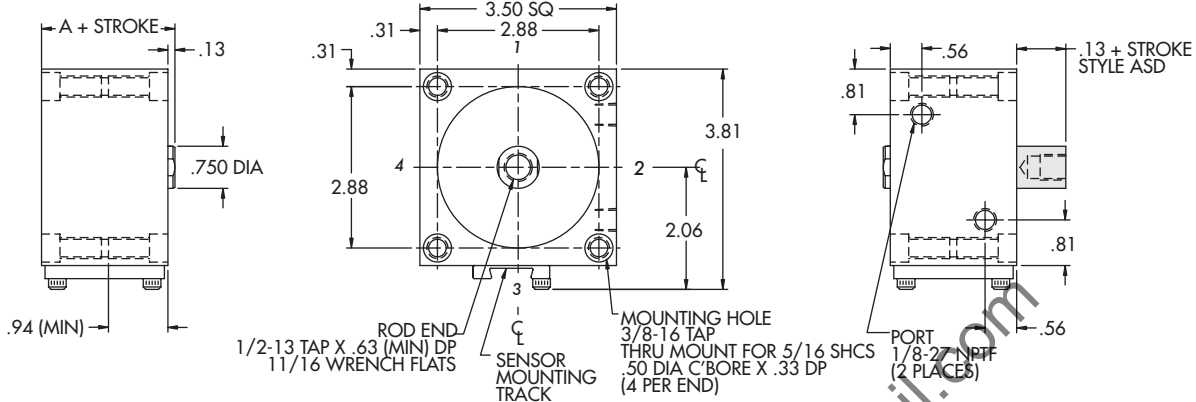

Duty	Part Number		Standard Stroke Length	A
	Single Rod	Double Rod		
Standard	<b>AS3x</b> ___	<b>ASD3x</b> ___	5/8 to 1-1/4 in 1/8" increments	1.88
Intermediate	<b>ASHH3x</b> ___		3/8 to 1 in 1/8" increments	2.13
Heavy	<b>ASFH3x</b> ___	<b>ASFHD3x</b> ___	1/8 to 3/4 in 1/8" increments	2.38

Standard Mounting: **TF, TR, TBE, TM**    Optional Porting: **1/4-18 NPTF**

Information same as above except where noted.

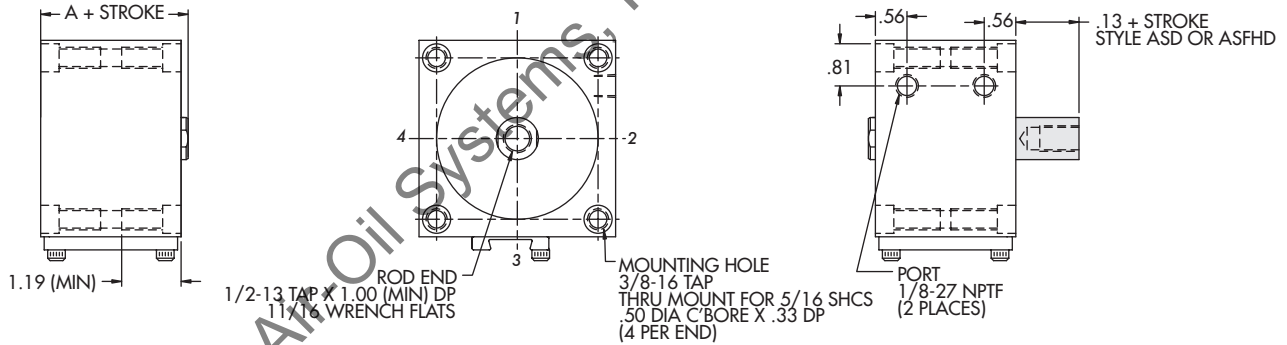

Duty	Part Number		Standard Stroke Length	A
	Single Rod	Double Rod		
Standard	<b>AS3x</b> ___	<b>ASD3x</b> ___	1-3/8 to 6 in 1/8" increments	1.88
Intermediate	<b>ASHH3x</b> ___		1-1/8 to 6 in 1/8" increments	2.13
Heavy	<b>ASFH3x</b> ___	<b>ASFHD3x</b> ___	7/8 to 6 in 1/8" increments	2.38

Standard Mounting: **TF**    Optional Mounting: **TR, TBE, TM**    Optional Porting: **1/4-18 NPTF**

Information same as above except where noted.

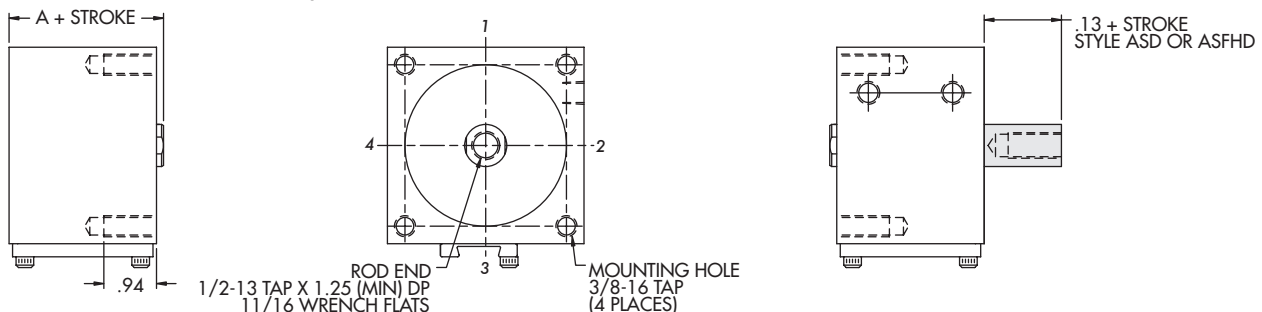

Style "B"



Side Mount

# 3" Bore Non Magnetic Piston

Duty	Part Number		Standard Stroke Length	A
	Single Rod	Double Rod		
Standard	<b>B3x</b> __	<b>BD3x</b> __	1/8 to 3/4 in 1/8" increments	1.63
Intermediate	<b>BHH3x</b> __		1/8 to 1/2 in 1/8" increments	1.88
Heavy	<b>BFH3x</b> __	<b>BFHD3x</b> __	1/8, 1/4	2.13



Optional Porting: **1/4-18 NPTF**

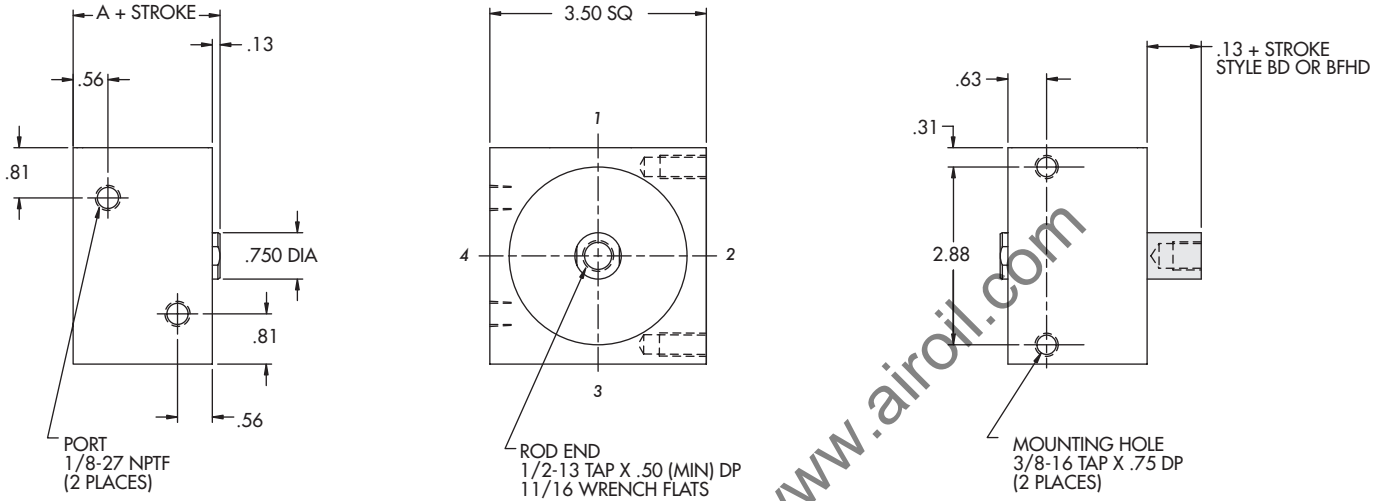

Duty	Part Number		Standard Stroke Length	A
	Single Rod	Double Rod		
Standard	<b>B3x</b> __	<b>BD3x</b> __	7/8 to 6 in 1/8" increments	1.63
Intermediate	<b>BHH3x</b> __		5/8 to 6 in 1/8" increments	1.88
Heavy	<b>BFH3x</b> __	<b>BFHD3x</b> __	3/8 to 6 in 1/8" increments	2.13

Optional Porting: **1/4-18 NPTF**

Information same as above except where noted.

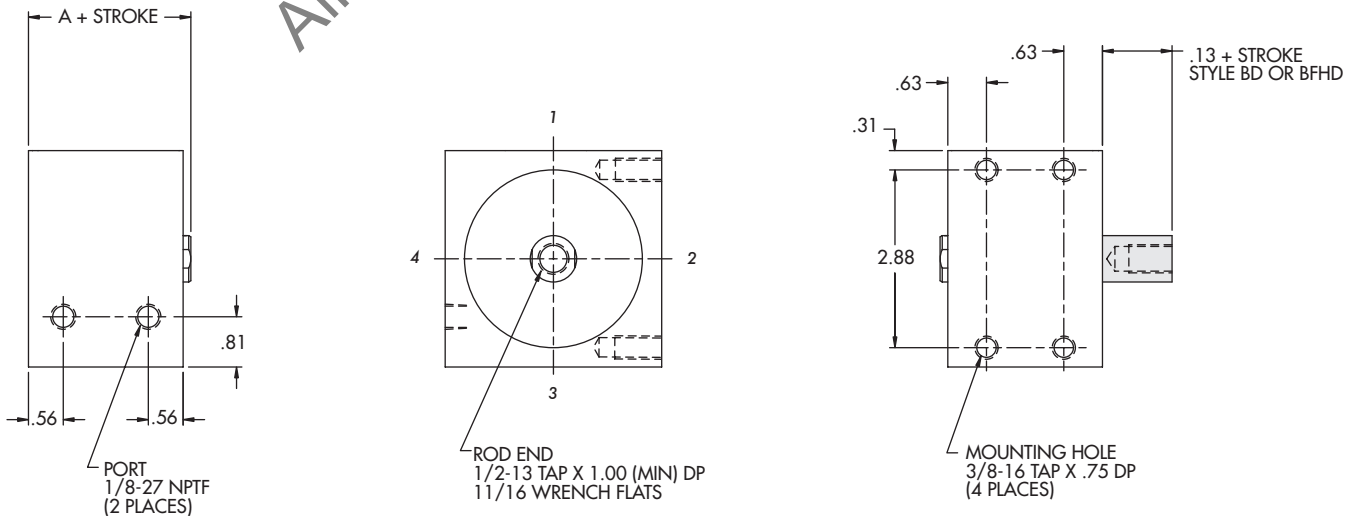



# 3" Bore Magnetic Piston

THIRD ANGLE PROJECTION



Duty	Part Number		Standard Stroke Length	A
	Single Rod	Double Rod		
Standard	<b>AB3x</b> __	<b>ABD3x</b> __	1/8 to 1/2 in 1/8" increments	1.88
Intermediate	<b>ABHH3x</b> __		1/8, 1/4	2.13

Optional Porting: **1/4-18 NPTF**

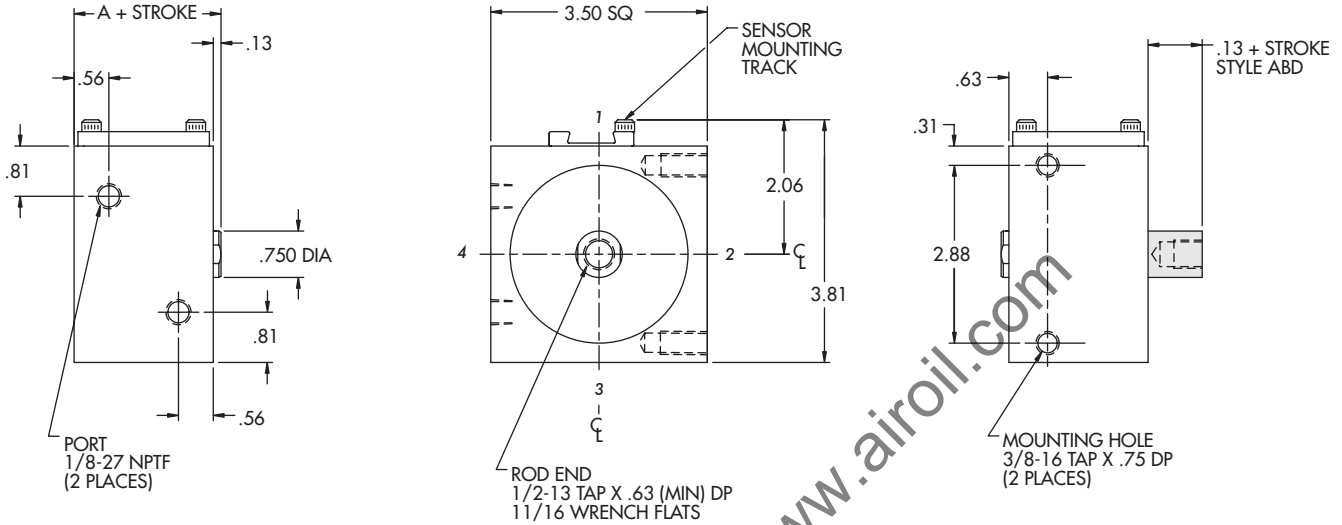

Duty	Part Number		Standard Stroke Length	A
	Single Rod	Double Rod		
Standard	<b>AB3x</b> __	<b>ABD3x</b> __	5/8 to 6 in 1/8" increments	1.88
Intermediate	<b>ABHH3x</b> __		3/8 to 6 in 1/8" increments	2.13
Heavy	<b>ABFH3x</b> __	<b>ABFHD3x</b> __	1/8 to 6 in 1/8" increments	2.38

Optional Porting: **1/4-18 NPTF**

Information same as above except where noted.

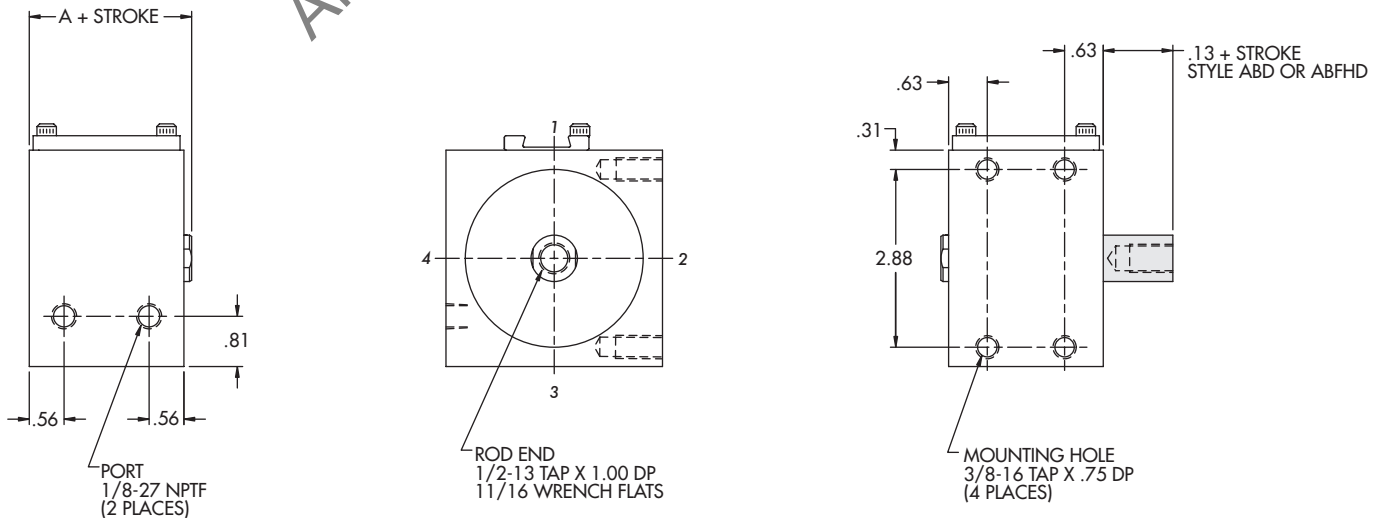



# 3" Bore Non Magnetic Piston

THIRD ANGLE PROJECTION

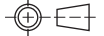

Duty	Part Number		Standard Stroke Length	A
	Single Rod	Double Rod		
Standard	<b>R3x</b> __	<b>RD3x</b> __	1/8 to 3/4 in 1/8" increments	1.63
Intermediate	<b>RHH3x</b> __		1/8 to 1/2 in 1/8" increments	1.88
Heavy	<b>RFH3x</b> __	<b>RFHD3x</b> __	1/8, 1/4	2.13

Standard Mounting: **TF, TR, TBE** Optional Mounting: **TM** Optional Porting: **1/4-18 NPTF**

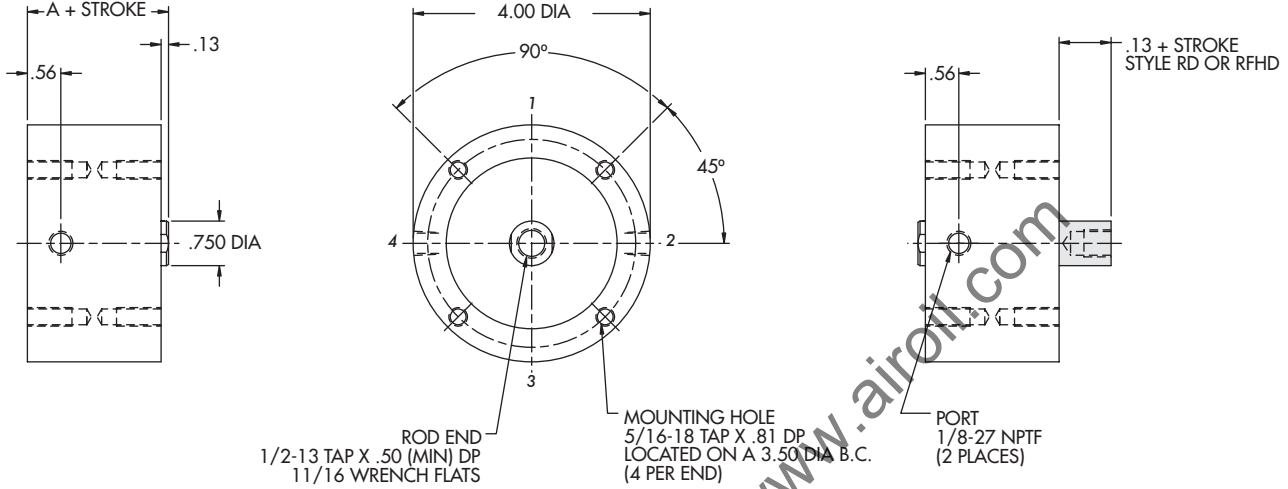

Duty	Part Number		Standard Stroke Length	A
	Single Rod	Double Rod		
Standard	<b>R3x</b> __	<b>RD3x</b> __	7/8 to 6 in 1/8" increments	1.63
Intermediate	<b>RHH3x</b> __		5/8 to 6 in 1/8" increments	1.88
Heavy	<b>RFH3x</b> __	<b>RFHD3x</b> __	3/8 to 6 in 1/8" increments	2.13

Standard Mounting: **TF** Optional Mounting: **TR, TBE, TM** Optional Porting: **1/4-18 NPTF**  
 Information same as above except where noted.

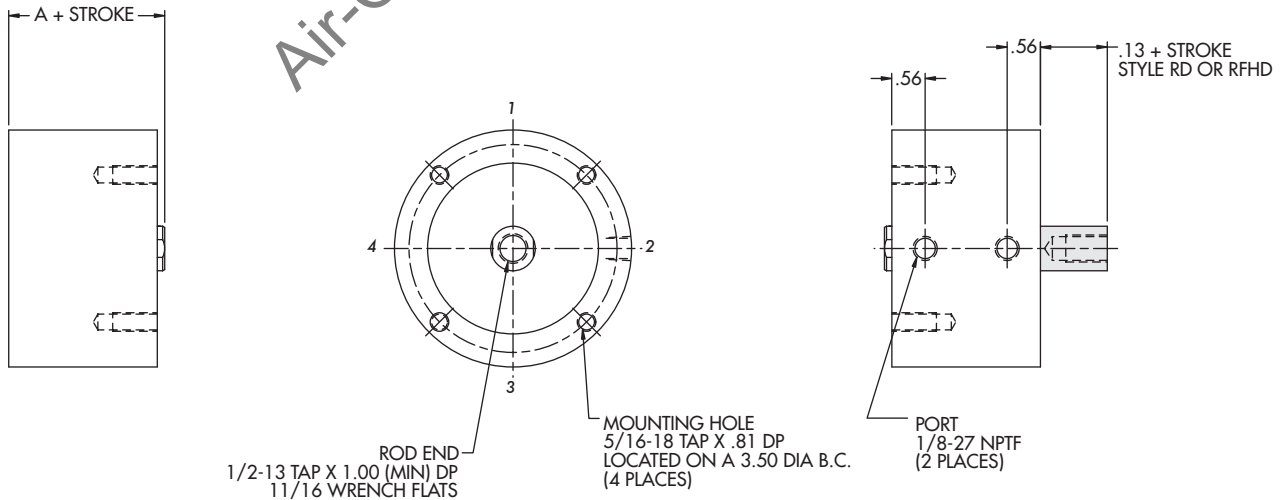



# 3" Bore Magnetic Piston

THIRD ANGLE PROJECTION

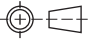

Duty	Part Number		Standard Stroke Length	A
	Single Rod	Double Rod		
Standard	AR3x__	ARD3x__	1/8 to 1/2 in 1/8" increments	1.88
Intermediate	ARHH3x__		1/8, 1/4	2.13

Standard Mounting: **TF, TR, TBE** Optional Mounting: **TM** Optional Porting: **1/4-18 NPTF**

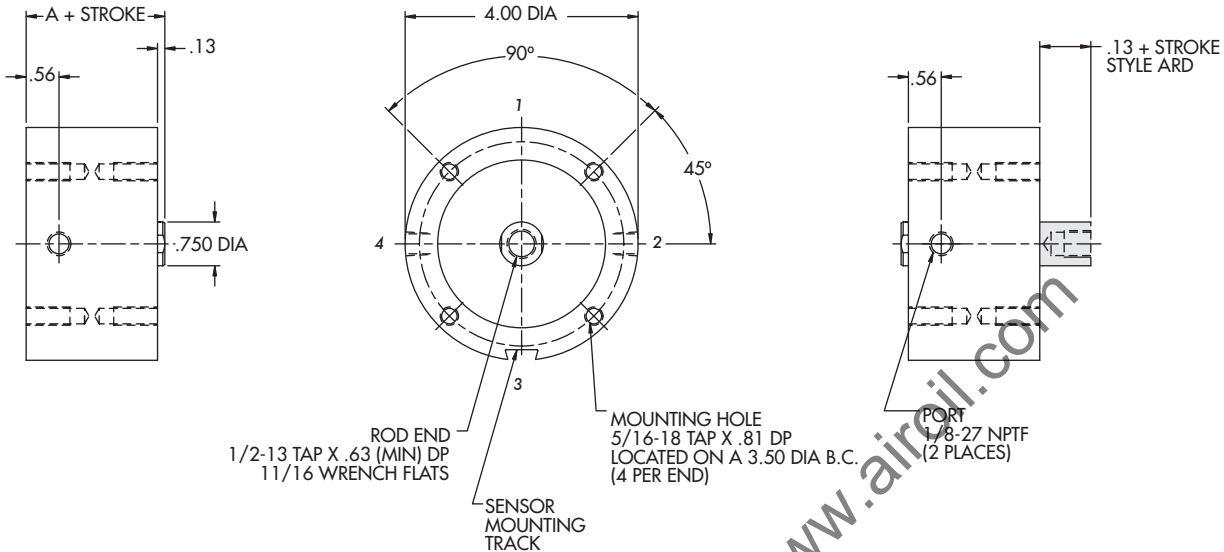

Duty	Part Number		Standard Stroke Length	A
	Single Rod	Double Rod		
Standard	AR3x__	ARD3x__	5/8 to 6 in 1/8" increments	1.88
Intermediate	ARHH3x__		3/8 to 6 in 1/8" increments	2.13
Heavy	ARFH3x__	ARFHD3x__	1/8 to 6 in 1/8" increments	2.38

Standard Mounting: **TF** Optional Mounting: **TR, TBE, TM** Optional Porting: **1/4-18 NPTF**  
 Information same as above except where noted.

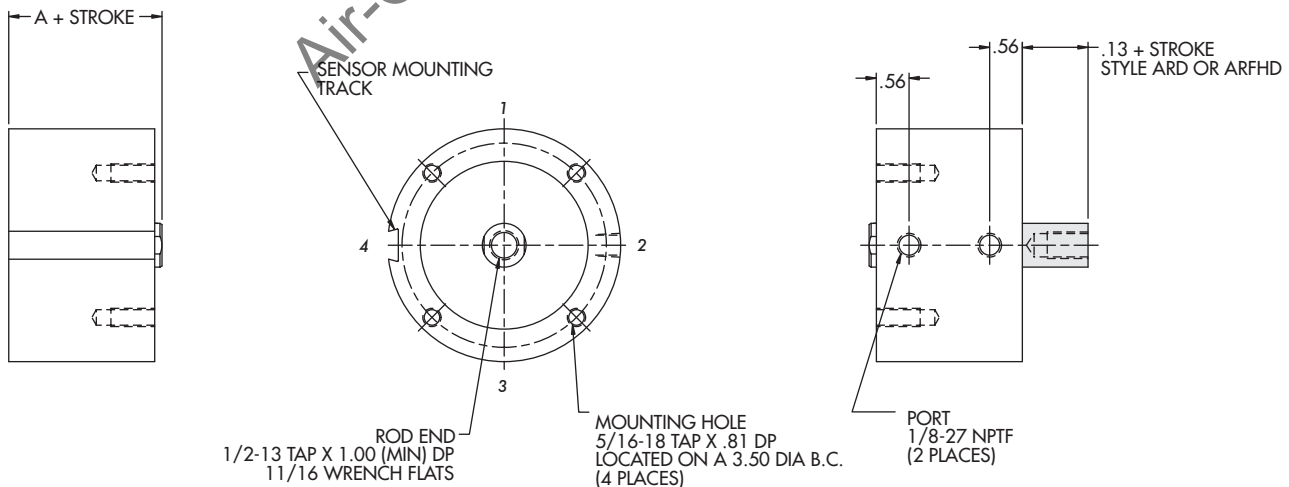



# 4" Bore Non Magnetic Piston

THIRD ANGLE PROJECTION

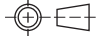

Duty	Part Number		Standard Stroke Length	A
	Single Rod	Double Rod		
Standard	<b>R4x</b> __	<b>RD4x</b> __	1/8 to 3/4 in 1/8" increments	1.75
Intermediate	<b>RHH4x</b> __		1/8 to 1/2 in 1/8" increments	2.00
Heavy	<b>RFH4x</b> __	<b>RFHD4x</b> __	1/8, 1/4	2.25

Standard Mounting: **TF, TR, TBE**    Optional Mounting: **TM**    Optional Porting: **1/4-18 NPTF**

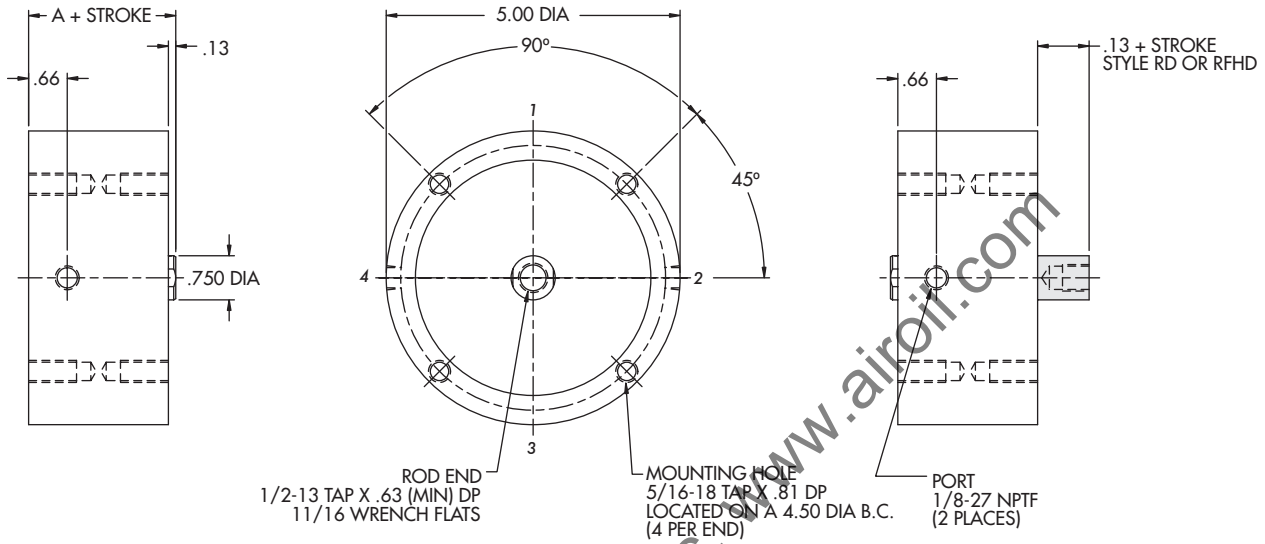

Duty	Part Number		Standard Stroke Length	A
	Single Rod	Double Rod		
Standard	<b>R4x</b> __	<b>RD4x</b> __	7/8 to 6 in 1/8" increments	1.75
Intermediate	<b>RHH4x</b> __		5/8 to 6 in 1/8" increments	2.00
Heavy	<b>RFH4x</b> __	<b>RFHD4x</b> __	3/8 to 6 in 1/8" increments	2.25

Standard Mounting: **TF**    Optional Mounting: **TR, TBE, TM**    Optional Porting: **1/4-18 NPTF**

Information same as above except where noted.

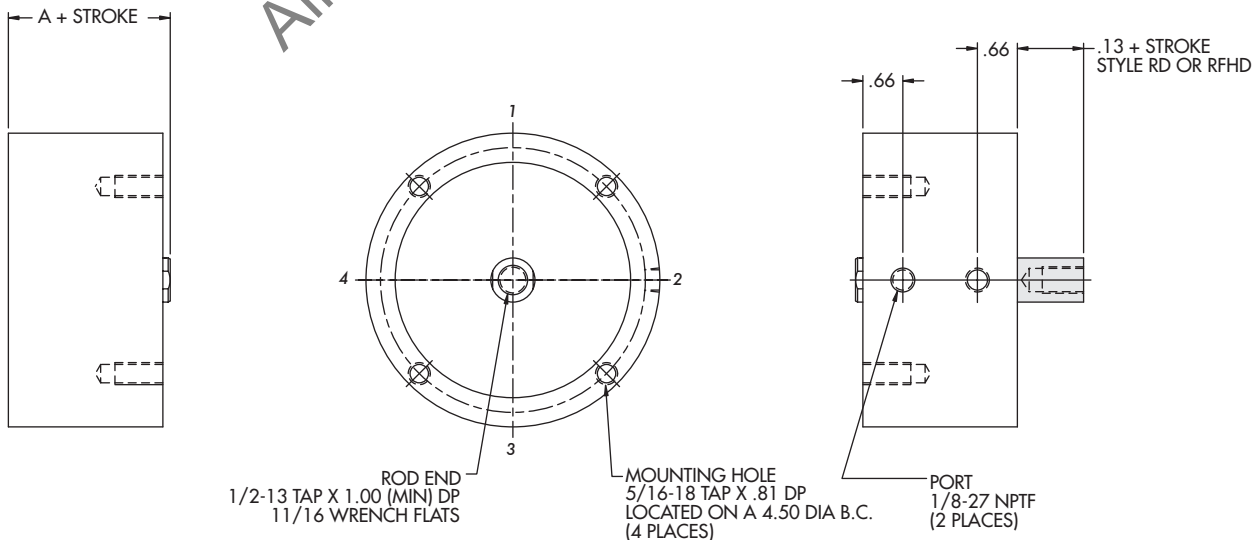





# 4" Bore Magnetic Piston

THIRD ANGLE PROJECTION



Duty	Part Number		Standard Stroke Length	A
	Single Rod	Double Rod		
Standard	AR4x__	ARD4x__	1/8 to 1/2 in 1/8" increments	2.00
Intermediate	ARHH4x__		1/8, 1/4	2.25

Standard Mounting: **TF, TR, TBE**    Optional Mounting: **TM**    Optional Porting: **1/4-18 NPTF**

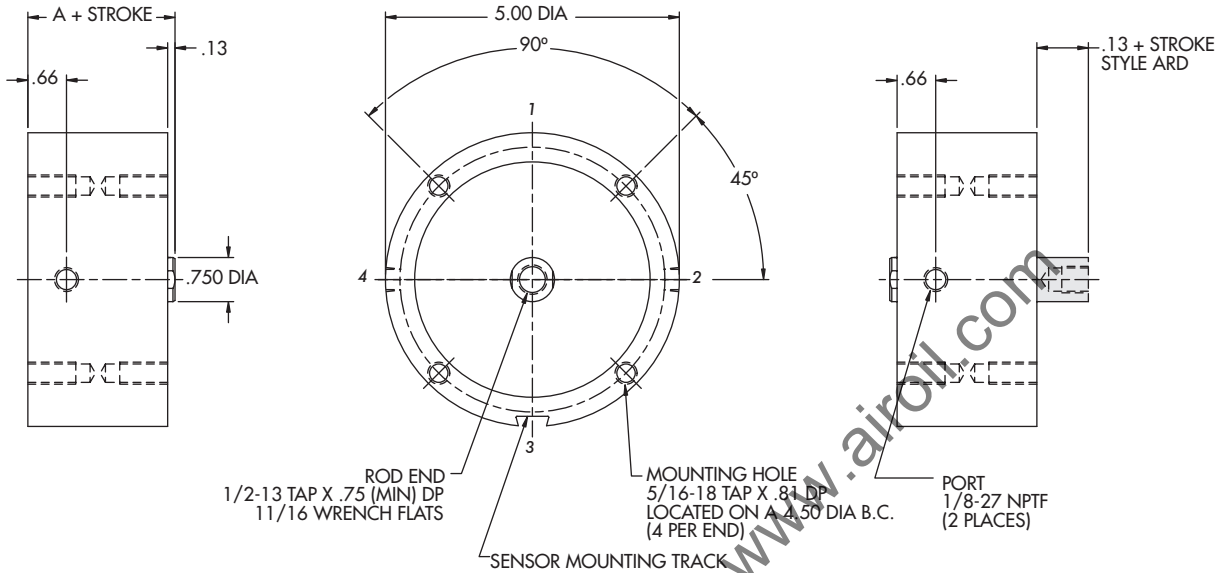

Duty	Part Number		Standard Stroke Length	A
	Single Rod	Double Rod		
Standard	AR4x__	ARD4x__	5/8 to 6 in 1/8" increments	2.00
Intermediate	ARHH4x__		3/8 to 6 in 1/8" increments	2.25
Heavy	ARFH4x__	ARFHD4x__	1/8 to 6 in 1/8" increments	2.50

Standard Mounting: **TF**    Optional Mounting: **TR, TBE, TM**    Optional Porting: **1/4-18 NPTF**

Information same as above except where noted.

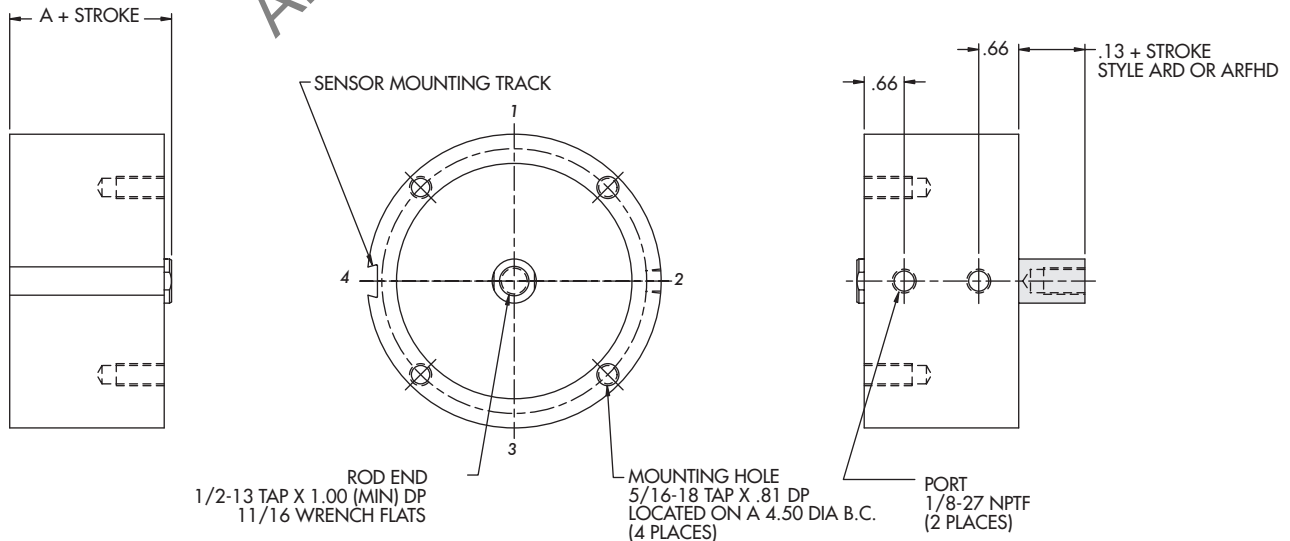



# 5" Bore Non Magnetic Piston

Duty	Part Number		Standard Stroke Length	A	B	C
	Single Rod	Double Rod				
Standard	<b>R5x</b> __	<b>RD5x</b> __	1/8 to 3/4 in 1/8" increments	1.88	.750	1/2-13 x .63 (Min.) Dp 11/16 Wrench Flats
Intermediate	<b>RHH5x</b> __		1/8 to 1/2 in 1/8" increments	2.13	.750	1/2-13 x .75 (Min.) Dp 11/16 Wrench Flats
Heavy	<b>RFH5x</b> __	<b>RFHD5x</b> __	1/8, 1/4	2.38	1.000	5/8-18 x .88 (Min.) Dp 15/16 Wrench Flats

THIRD ANGLE PROJECTION



Standard Mounting: **TF, TR, TBE** Optional Mounting: **TM** Optional Porting: **1/4-18 NPTF**

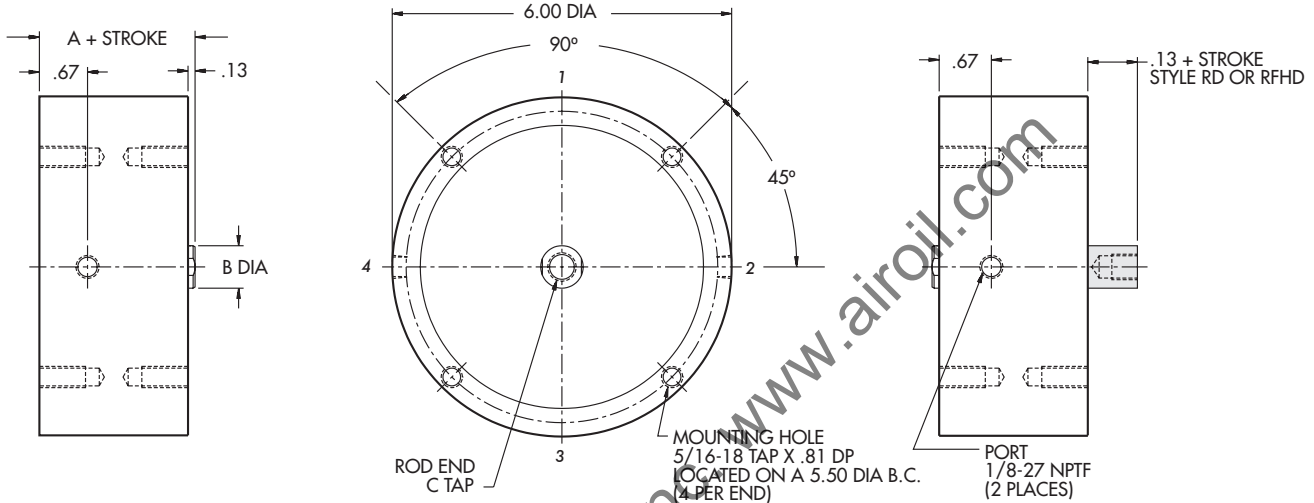

Duty	Part Number		Standard Stroke Length	A	B	C
	Single Rod	Double Rod				
Standard	<b>R5x</b> __	<b>RD5x</b> __	7/8 to 6 in 1/8" increments	1.88	.750	1/2-13 x .1.00 (Min.) Dp 11/16 Wrench Flats
Intermediate	<b>RHH5x</b> __		5/8 to 6 in 1/8" increments	2.13	.750	1/2-13 x 1.00 (Min.) Dp 11/16 Wrench Flats
Heavy	<b>RFH5x</b> __	<b>RFHD5x</b> __	3/8 to 6 in 1/8" increments	2.38	1.000	5/8-18 x 1.00 (Min.) Dp 15/16 Wrench Flats

Standard Mounting: **TF** Optional Mounting: **TR, TBE, TM** Optional Porting: **1/4-18 NPTF**

Information same as above except where noted.

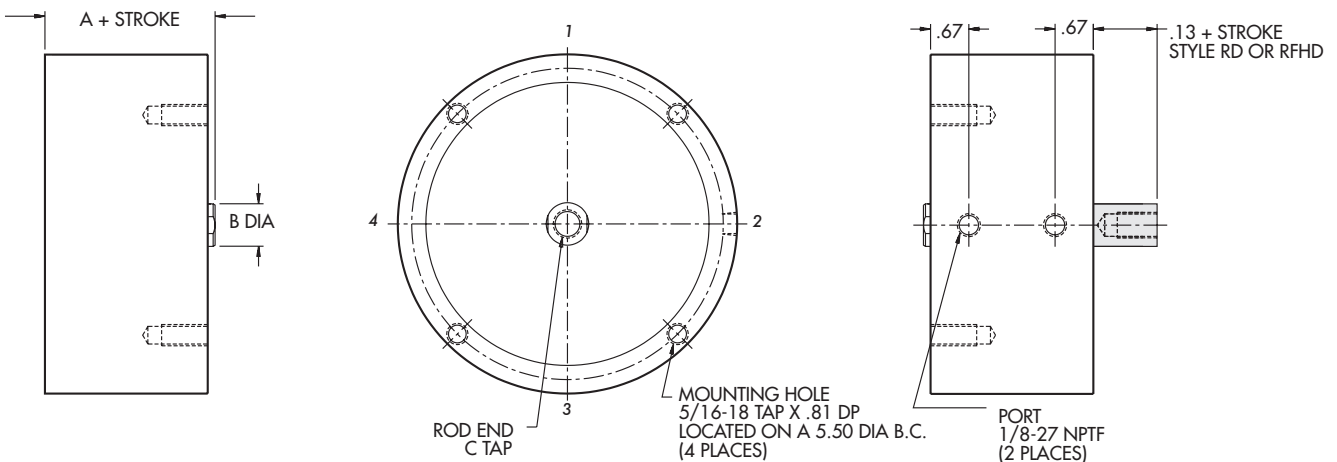



# 5" Bore Magnetic Piston

THIRD ANGLE PROJECTION



Duty	Part Number		Standard Stroke Length	A	B	C
	Single Rod	Double Rod				
Standard	<b>AR5x__</b>	<b>ARD5x__</b>	1/8 to 1/2 in 1/8" increments	2.13	.750	1/2-13 x .75 (Min.) Dp 11/16 Wrench Flats
Intermediate	<b>ARHH5x__</b>		1/8, 1/4	2.38	.750	1/2-13 x .88 (Min.) Dp 11/16 Wrench Flats

Standard Mounting: **TF, TR, TBE** Optional Mounting: **TM** Optional Porting: **1/4-18 NPTF**

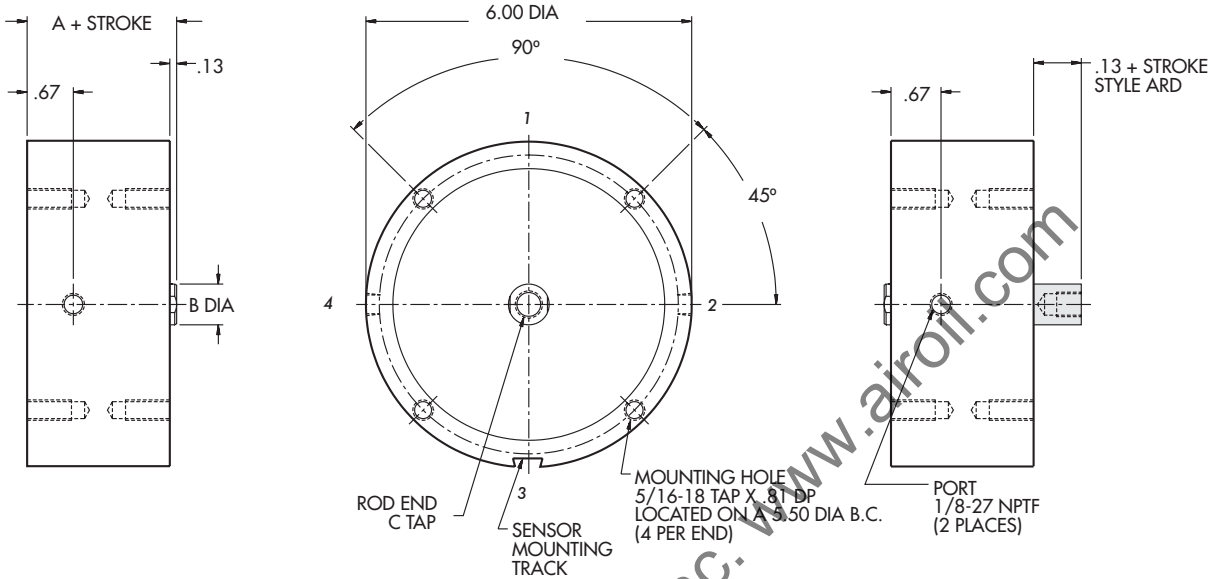

Duty	Part Number		Standard Stroke Length	A	B	C
	Single Rod	Double Rod				
Standard	<b>AR5x__</b>	<b>ARD5x__</b>	5/8 to 6 in 1/8" increments	2.13	.750	1/2-13 x .1.00 (Min.) Dp 11/16 Wrench Flats
Intermediate	<b>ARHH5x__</b>		3/8 to 6 in 1/8" increments	2.38	.750	1/2-13 x 1.00 (Min.) Dp 11/16 Wrench Flats
Heavy	<b>ARFH5x__</b>	<b>ARFHD5x__</b>	1/8 to 6 in 1/8" increments	2.63	1.000	5/8-18 x 88 (Min.) Dp 15/16 Wrench Flats

Standard Mounting: **TF** Optional Mounting: **TR, TBE, TM** Optional Porting: **1/4-18 NPTF**

Information same as above except where noted.

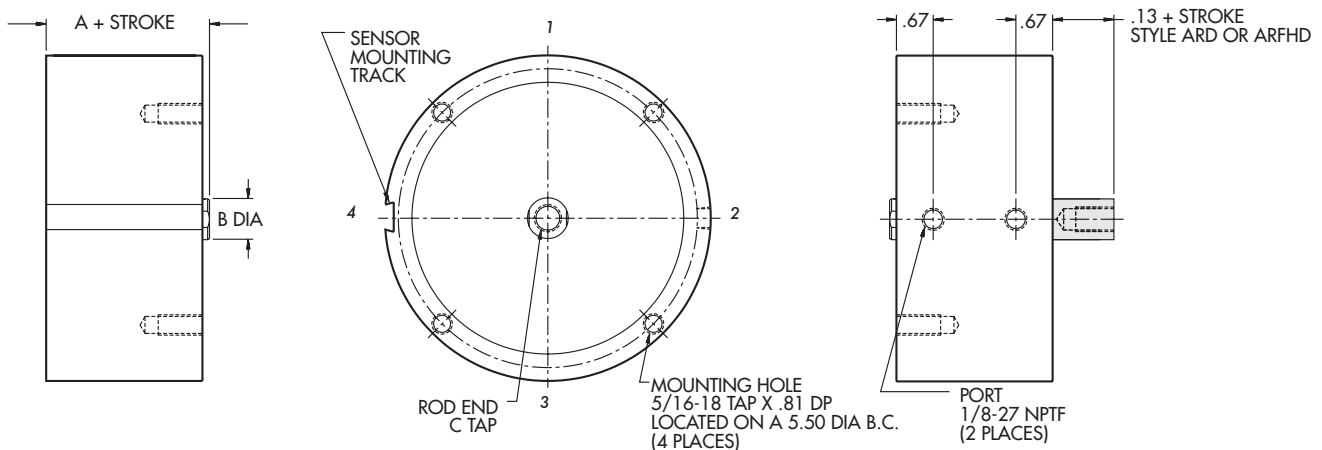

Style "R"



End Mount

# 6" Bore Non Magnetic Piston

Duty	Part Number		Standard Stroke Length	A
	Single Rod	Double Rod		
Standard	R6x__	RD6x__	1/8 to 1/2 in 1/8" increments	2.13

THIRD ANGLE PROJECTION

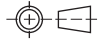

Standard Mounting: **TF, TR, TBE**    Optional Mounting: **TM**    Optional Porting: **1/4-18 NPTF**

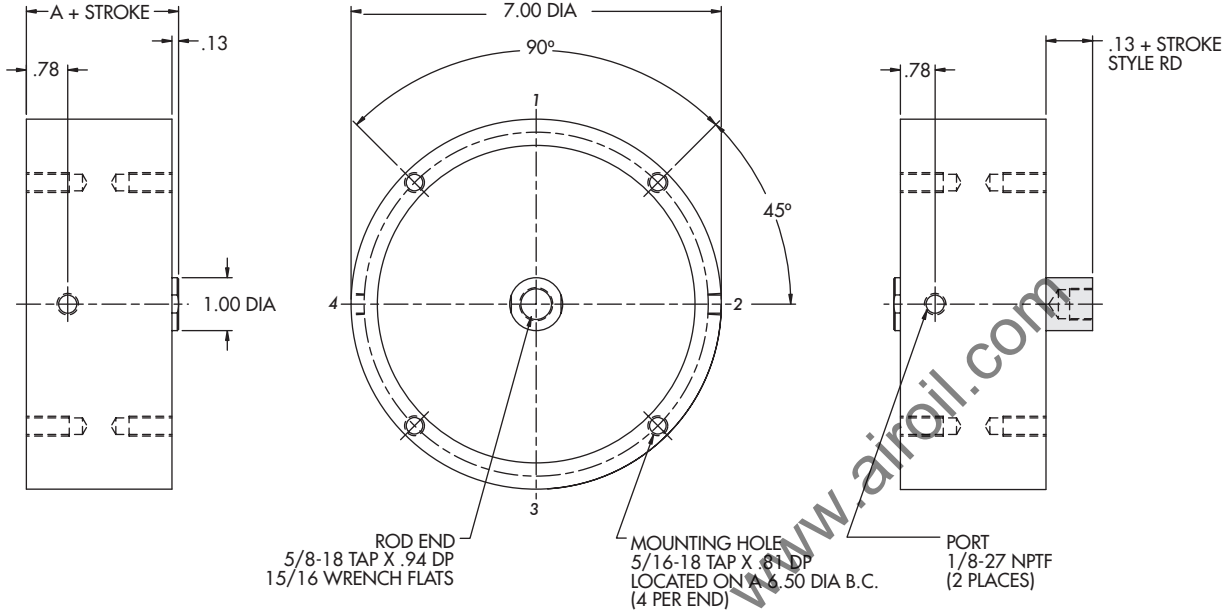

Duty	Part Number		Standard Stroke Length	A
	Single Rod	Double Rod		
Standard	R6x__	RD6x__	5/8 to 6 in 1/8" increments	2.13

Standard Mounting: **TF**    Optional Mounting: **TR, TBE, TM**    Optional Porting: **1/4-18 NPTF**

Information same as above except where noted.

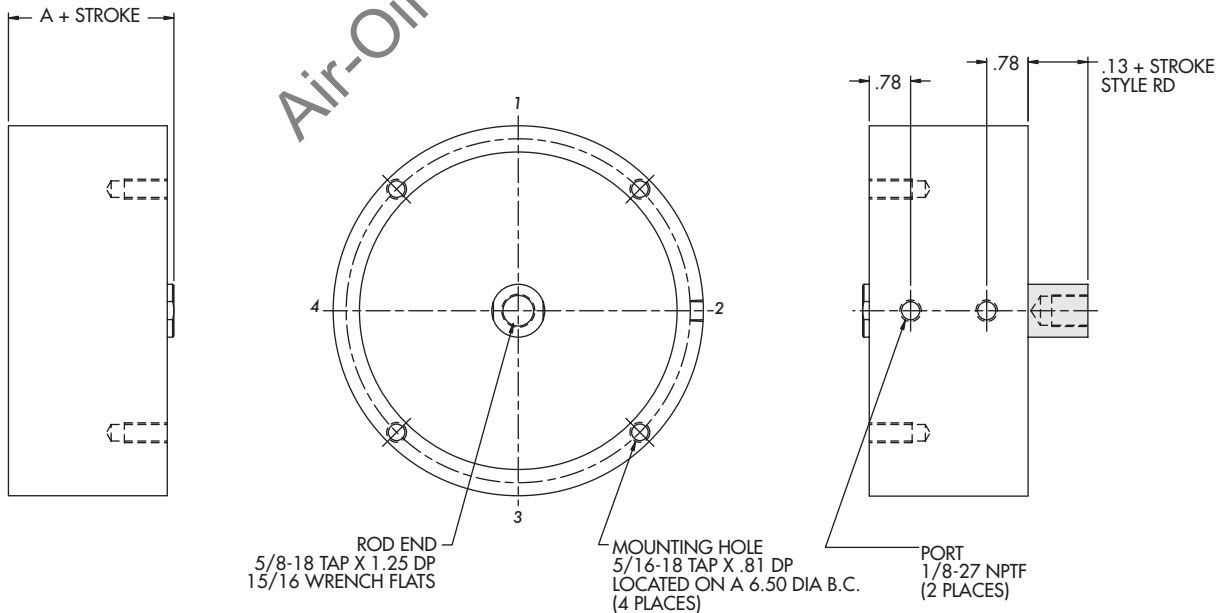



# 6" Bore Magnetic Piston

THIRD ANGLE PROJECTION

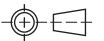

Duty	Part Number		Standard Stroke Length	A
	Single Rod	Double Rod		
Standard	AR6x__	ARD6x__	1/8, 1/4	2.38

Standard Mounting: **TF, TR, TBE**    Optional Mounting: **TM**    Optional Porting: **1/4-18 NPTF**

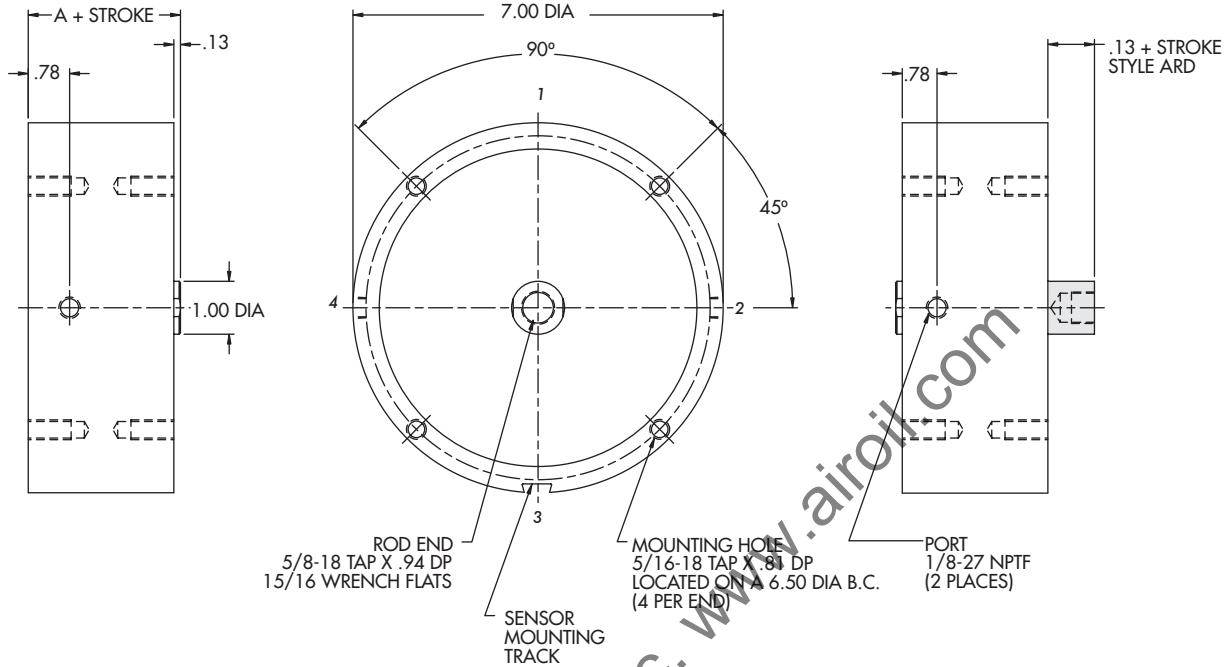

Duty	Part Number		Standard Stroke Length	A
	Single Rod	Double Rod		
Standard	AR6x__	ARD6x__	3/8 to 6 in 1/8" increments	2.38

Standard Mounting: **TF**    Optional Mounting: **TR, TBE, TM**    Optional Porting: **1/4-18 NPTF**

Information same as above except where noted.

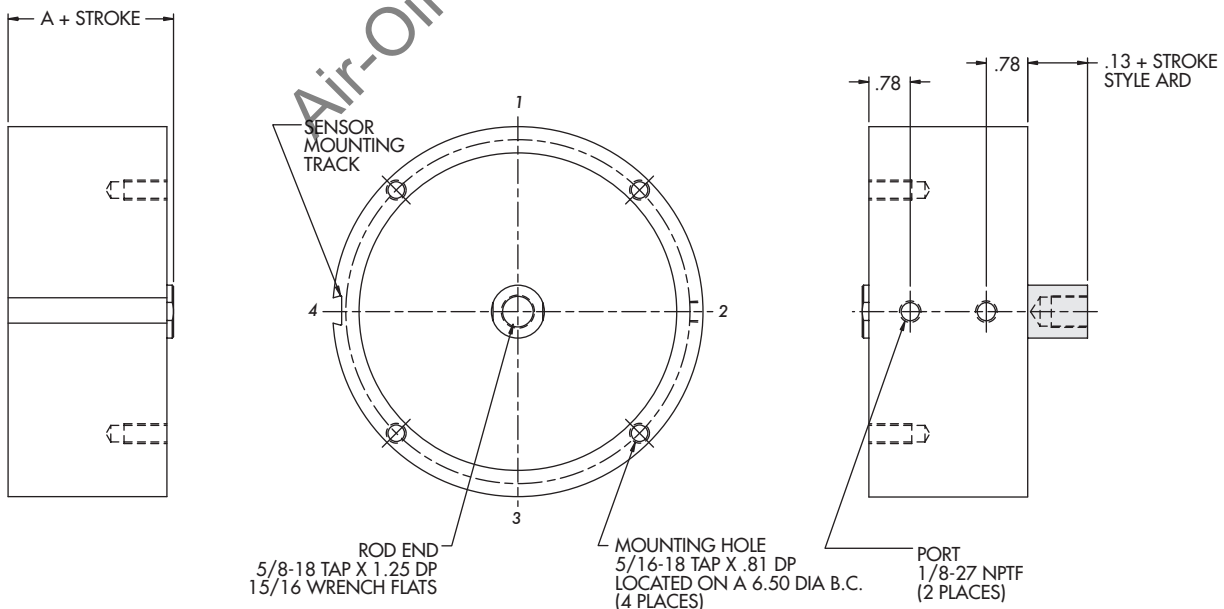

Style "R"



End Mount

# 8" Bore Non Magnetic Piston

THIRD ANGLE PROJECTION

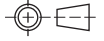

Duty	Part Number		Standard Stroke Length	A
	Single Rod	Double Rod		
Standard	<b>R8x</b> ___	<b>RD8x</b> ___	1/8 to 1/2 in 1/8" increments	2.38

Standard Mounting: **TF, TR, TBE**    Optional Mounting: **TM**    Optional Porting: **1/4-18 NPTF**

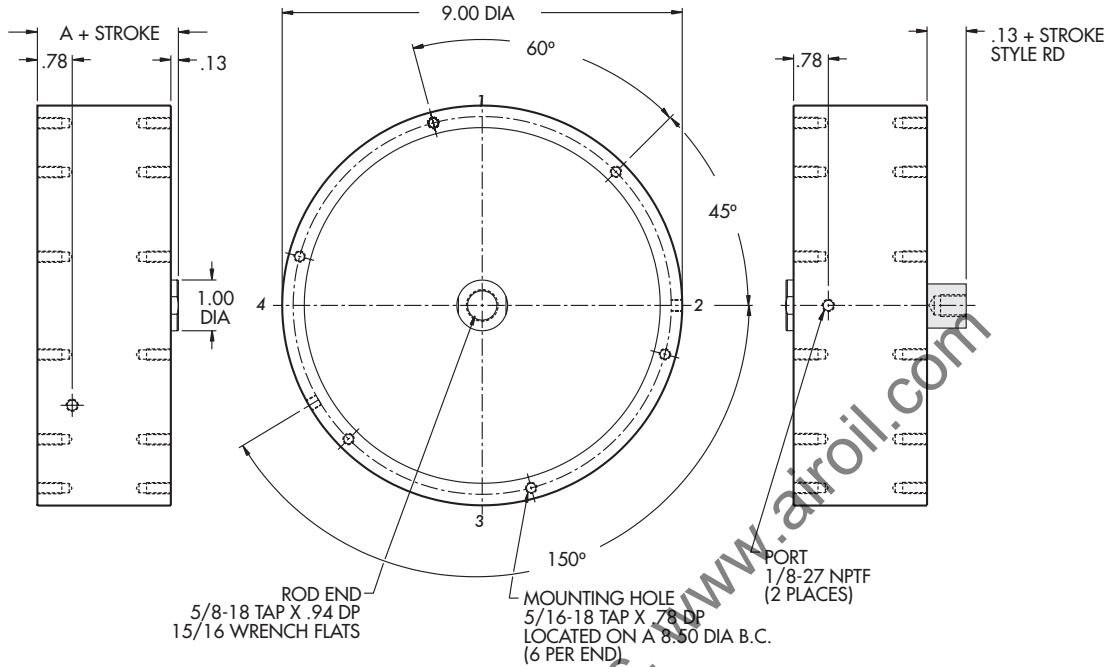

Duty	Part Number		Standard Stroke Length	A
	Single Rod	Double Rod		
Standard	<b>R8x</b> ___	<b>RD8x</b> ___	5/8 to 6 in 1/8" increments	2.38

Standard Mounting: **TF**    Optional Mounting: **TR, TBE, TM**    Optional Porting: **1/4-18 NPTF**

Information same as above except where noted.

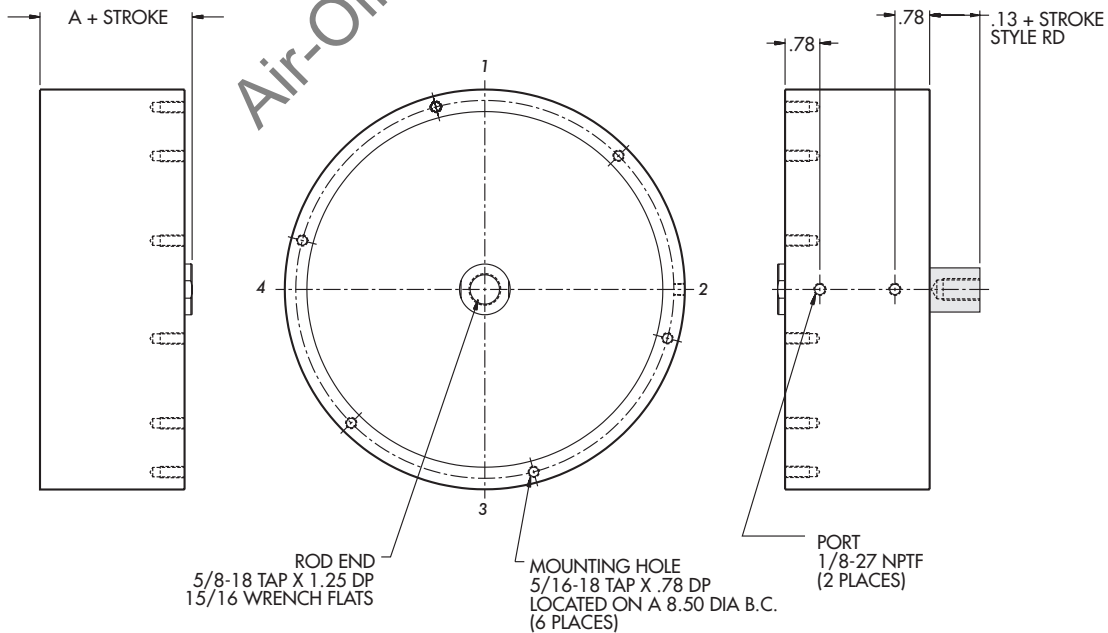



# 8" Bore Magnetic Piston

THIRD ANGLE PROJECTION

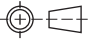

Duty	Part Number		Standard Stroke Length	A
	Single Rod	Double Rod		
Standard	AR8x__	ARD8x__	1/8, 1/4	2.63

Standard Mounting: **TF, TR, TBE**    Optional Mounting: **TM**    Optional Porting: **1/4-18 NPTF**

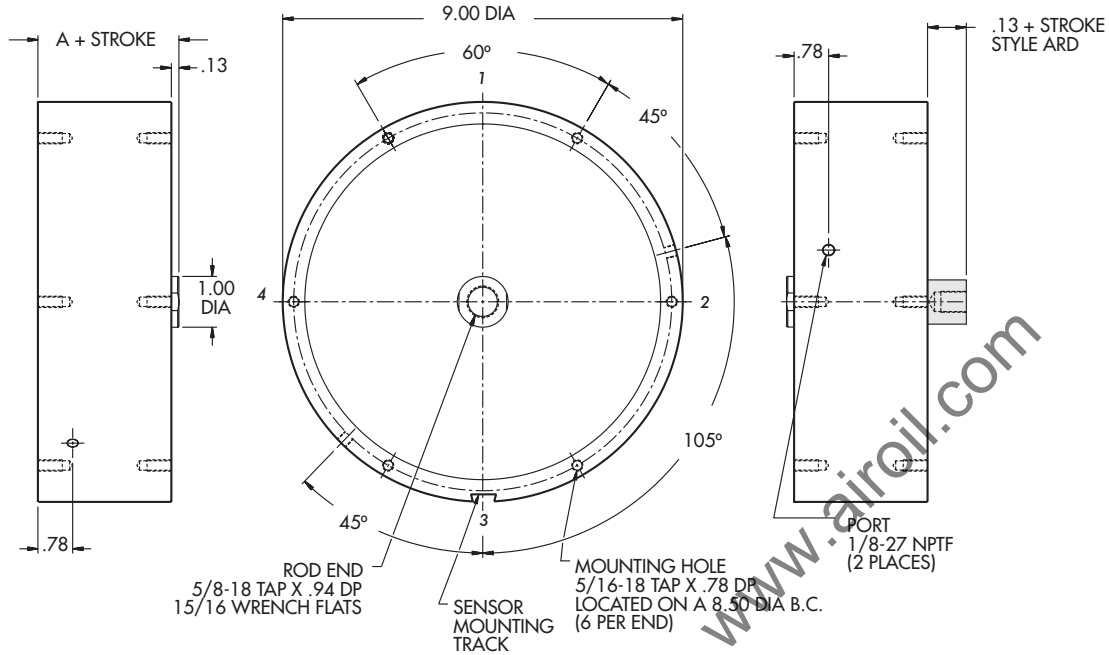

Duty	Part Number		Standard Stroke Length	A
	Single Rod	Double Rod		
Standard	AR8x__	ARD8x__	3/8 to 6 in 1/8" increments	2.63

Standard Mounting: **TF**    Optional Mounting: **TR, TBE, TM**    Optional Porting: **1/4-18 NPTF**

Information same as above except where noted.

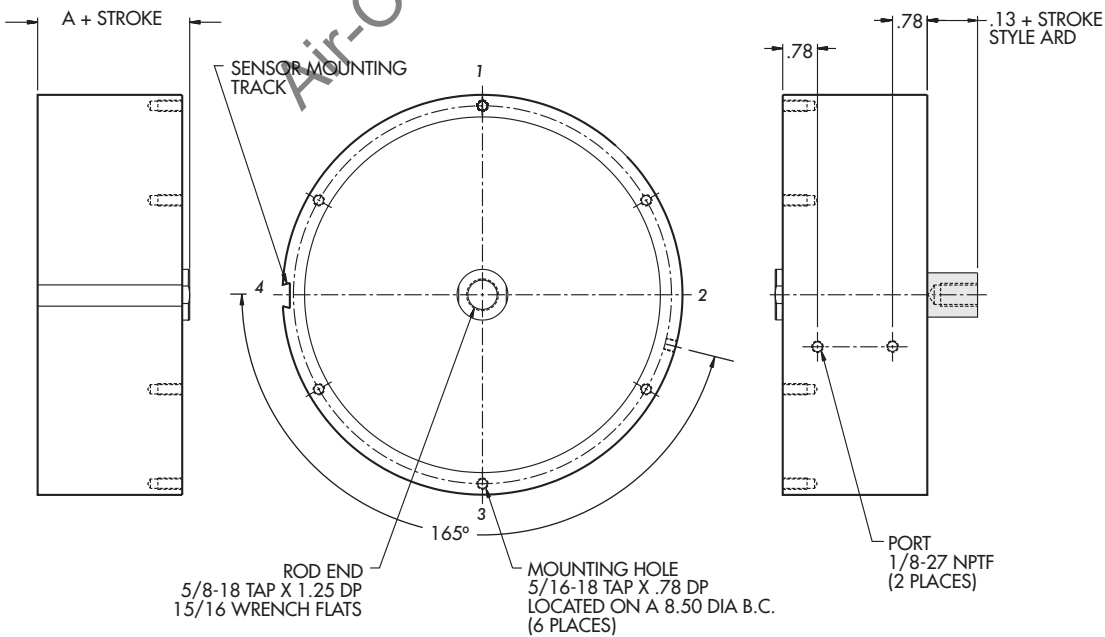

# Seal Descriptions

Conversion Formula:  $C^{\circ} = (F^{\circ} - 32^{\circ}) \times 5/9$

Type	Ordering Suffix	Rating	Description
<b>Pneumatic Seals</b>			
Nitrile	-	0° to 200°F -18° to 93°C	Most commonly used elastomer O-ring due to its excellent resistance to petroleum products, wear, tear and friction. Works with lubricated or non-lubricated air in the noted temperature range. Recommended for general purpose sealing with petroleum oils and fluids, water and silicone greases and oils.
Fluorocarbon	<b>HTV</b>	0° to 400°F -18° to 204°C	Used mainly for elevated temperatures, harsh environments where some coolants, solvents, cleaning agents or other chemicals will contact the seal gland. Lower compression set is characteristic. For your specific requirements, consult factory.
PTFE*	<b>CRT</b>	250° to 400°F 121° to 204°C	Specified for extreme temperatures and harsh atmosphere where rubber seals are not suitable. Best compression set is at high temperature. PTFE seals are not guaranteed to be leak free and higher breakaway is typical. Overall strength does not compare favorably to rubber in abrasion resistance.
Ethylene Propylene	<b>ETP</b>	-70° to 300°F -57° to 150°C	Used for sealing water, phosphate-ester hydraulic fluids, glycol base brake fluids, silicone oils and grease, many acids, solvents. Not compatible with mineral oil products. Consult factory for specific applications.
<b>Hydraulic Seals</b>			
Nitrile*	<b>HYD</b>	0° to 250°F -18° to 121°C	Seal material is Nitrile and Urethane. Moderate resistance to abrasion, high pressure and shock. Low temperature decreases flexibility. Recommended for hydraulic fluids, dilute acids, and water.
Fluorocarbon*	<b>VHYD</b>	0° to 400°F -18° to 204°C	Seal material is fluorocarbon and PTFE. This option is designed to operate over an extremely wide elevated temperature range, harsh environment or with any non-oil based synthetic hydraulic fluids.

\*Available through 4" bore only

Air-Oil Systems, Inc. www.airoil.com





# 3/4" - 3" Bore Options

## Corrosion Resistant 300 Series Stainless Steel

### Standard Duty Features:

- 100% 300 series stainless steel components – interior and exterior
- Viton® seals (Teflon® seals, suffix "CRT", are optional)
- Plastic rod bearings

### Intermediate and Heavy Duty Features:

- 100% 300 series stainless steel components – interior and exterior
- Viton® seals (Teflon® seals, suffix "CRT", are optional)
- UHMW plastic rod bearings

*Optional* - A Crystalline PET Thermoplastic Polyester rod bearing is available for use in clean-room environments. Consult Factory for details.

### Magnetic Piston Cylinders:

- Bolt-on Mounting Track is aluminum only

**Ordering:** Specify "CR3" **before** cylinder part number  
Available on 3/4" through 3"

**Delivery:** Non-standard delivery, consult factory

### CR3

**Ordering Prefix:** CR3

**Bore:** 3/4" - 3"

**Material:** 300 Series stainless steel

**Stroke:** 1/8 - 4 in 1/8" increments

### Applications:

- Chemical / Petroleum
- Medical Equipment
- Salt Water Exposure
- Clean Rooms
- Food Processing
- Electronic Assembly
- Nuclear
- Pharmaceutical



## Adjustable Retract Stroke

Bore	A	B
3/4	.56	1/4-20
1-1/8	.75	3/8-16
1-3/8		
1-5/8		
2	1.00	1/2-13
2-1/2		
3	1.38	3/4-10
4		
5		
6		
8		

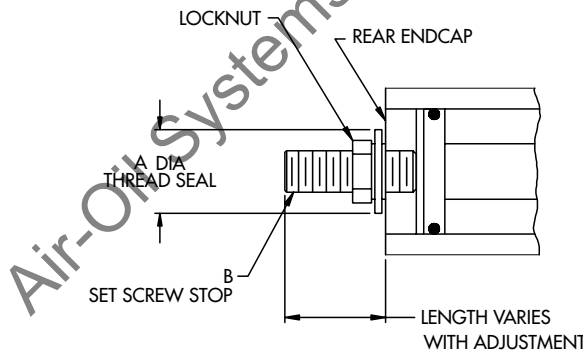

- DO NOT use with any pivoting applications

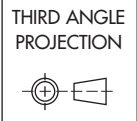

### ADJ\_

Specify Length

**Ordering Suffix:** ADJ\_

**Length:** 1/8 - 2 in 1/8" increments

**Rod:** Single only  
**Temperature:** 200°F Max.

**Material:** Aluminum endcap, steel locknut and thread seal

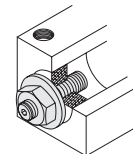

All dimensions are in inches unless otherwise noted.

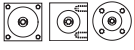

# 3/4" - 3" Bore Options

## Urethane Bumper Pads

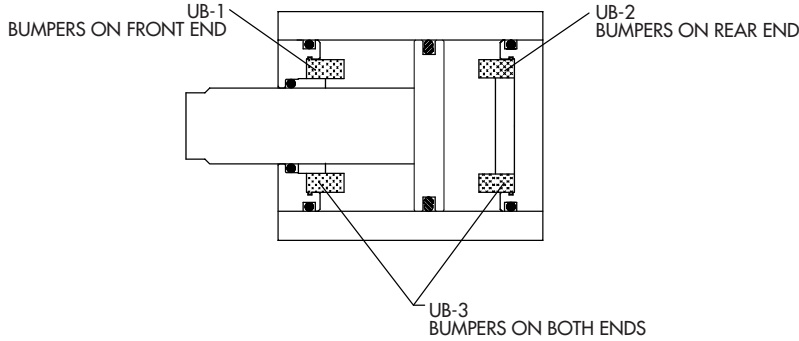

- Designed for noise reduction and minor piston impact only
- Cylinder length does not increase
- Stroke is decreased by 1/8" per bumper
- Bumper Pads mechanically retained within the endcap
- Repairable part - replaceable bumper pads

### UB\_

Example: UB1, UB2, UB3

**Ordering Suffix:** UB\_  
**Bore:** 3/4" - 3"  
**Temperature:** 0° - 150°F  
**Service:** Pneumatic only  
**Material:** Polyurethane

NOTE: UB1 not available with CR3 or NR option

This option does not replace external shock absorbers needed for high loads.

## Urethane Cushion Pads

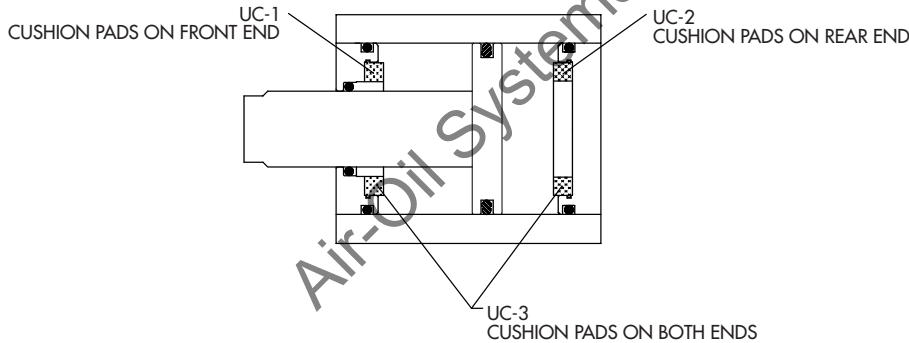

- Designed for noise reduction and minor piston impact only
- Cylinder length does not increase
- Cushion Pads mechanically retained within the endcap
- Repairable part - replaceable cushion pads

### UC\_

Example: UC1, UC2, UC3

**Ordering Suffix:** UC\_  
**Bore:** 3/4" - 3"  
**Temperature:** 0° - 150°F  
**Service:** Pneumatic only  
**Material:** Polyurethane

NOTE: UC1 not available with CR3 or NR option

This option does not replace external shock absorbers needed for high loads.

All dimensions are in inches unless otherwise noted.

# 3/4" - 8" Bore Options

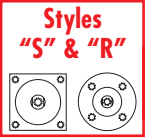

## Positive Alignment Pocket

The alignment pocket and pilot are designed to fit between the cylinder and the mounting surface. This ensures accurate mounting and added shear strength.

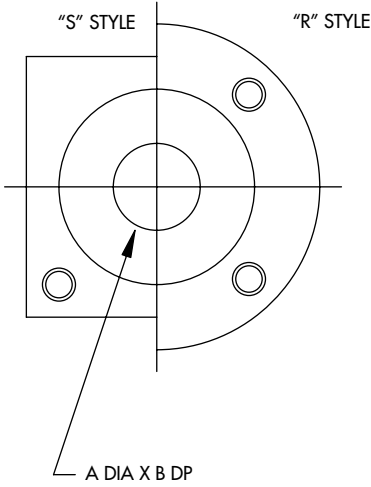

Bore	A	B
3/4	.31	.13
1-1/8	.50	.13
1-3/8	.63	.19
1-5/8		
2	.75	.25
2-1/2		
3		
4	1.50	.31
5		
6		
8		

### PA

**Ordering Suffix:** PA  
**Style:** "S" and "R" only  
**Rod:** Single only

- Provides positive means of locating cylinder centerline within .005"

## Positive Alignment sold separately

### Dual Diameter

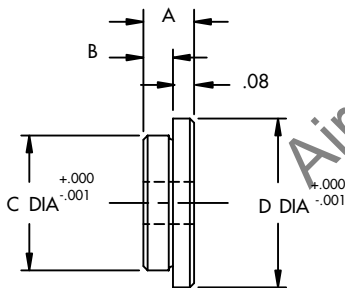

### Common Diameter

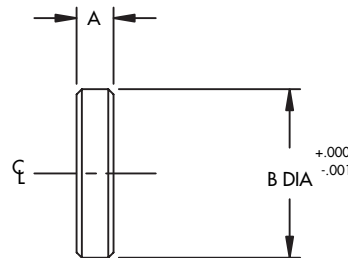

### PL

**Part Number:** PL\_  
**Rod:** Single only  
**Material:** Stainless steel

Bore	Part Number	A	B	C	D
1-1/8	PL118-05	.17	.09	.25	.50
	PL118-07	.19	.11	.31	.50
1-3/8	PL158-07	.19	.11	.31	.63
1-5/8	PL158-11	.19	.11	.50	.63

Bore	Part Number	A	B
3/4	PL12L	.20	.31
1-1/8	PL118L	.20	.50
1-3/8	PL158L	.30	.63
1-5/8			
2	PL2L	.41	.75
2-1/2			
3			
4	PL4L	.50	1.50
5			
6			
8			

All dimensions are in inches unless otherwise noted.

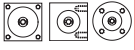

# 3/4" - 8" Bore Options

## Hollow Rod

Our hollow rod option is available for applications that require passage through a double ended rod.

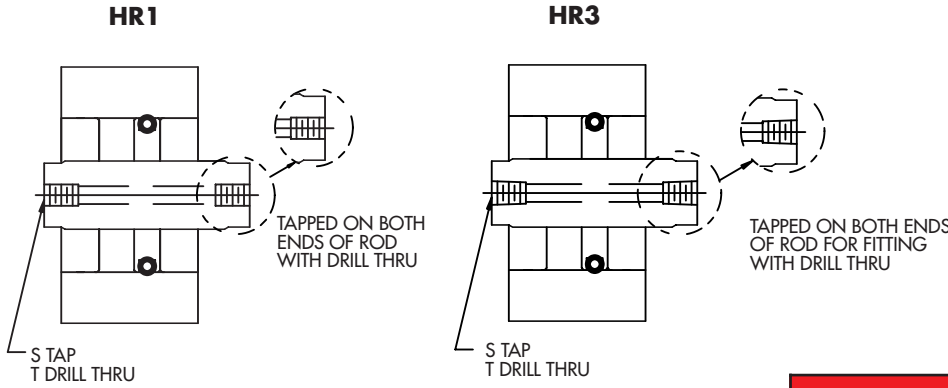

**HR**  
Specify Length  
**Ordering Suffix:** HR\_  
**Bore:** 3/4" - 2" only  
**Duty:** Standard and Full Husky only  
**Rod:** Double only  
**Service:** Pneumatic only  
**Stroke:** 1/8 - 2 in 1/8" increments

Bore	HR1		HR3	
	S Tap	T Drill Thru	S Tap	T Drill Thru
3/4	#10-24 x 3/8 Dp.	.14	#10-32 x 3/8 Dp	.16
1-1/8	5/16-18 x 5/8 Dp.	.25		
1-3/8				
1-5/8	3/8-16 x 3/4 Dp.	.31	1/8-27 NPTF	.34
2				

Applications		
Example	YES	NO
Gases	✓	
Liquids	✓	
Vacuum	✓	
Linear / Rotary Cylinder	✓	
Clamp and Punch Cylinder	✓	
Blow Molding Cylinder	✓	
Hydraulic Cylinders		X
Non-Rotating Rods		X

### Modifications Welcome

Special stroke lengths, port orientation, mounting configuration.

SPECIALS: Consult factory with ID requirements, thread information, pipe taps, etc.

## Rod End Extension

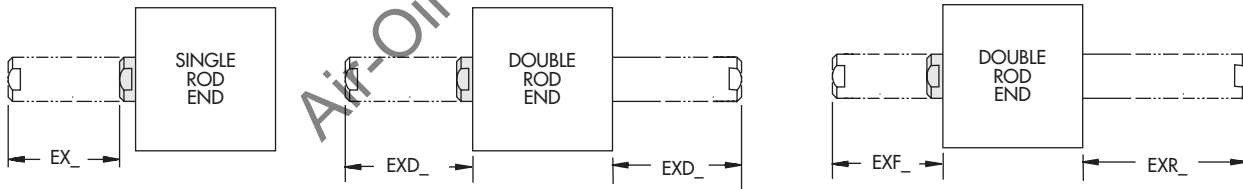

Extended equally at both ends

- For special extension or length - consult factory
- Not a screw on component
- Female tap does not change

Single Rod End      Double Rod End

**EX\_**

Specify Length

**EXD\_**

Specify Length

Extension Front End

**EXF\_**

Specify Length

Extension Rear End

**EXR\_**

Specify Length

**Ordering Suffix:** EX\_, EXD\_, EXF\_ or EXR\_

**Length:** 1/8 - 1 in 1/8" increments

All dimensions are in inches unless otherwise noted.

# 3/4" - 8" Bore Options

All Styles



## Clevis Bracket / Set Screw

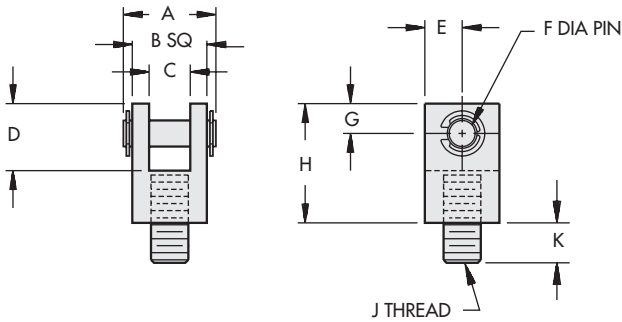

**CBSS\_**

Specify Screw Length

**Ordering Suffix:** CBSS\_

**Material:**

Steel black oxide  
with case  
hardened pin and  
clips  
CBSS78 = 7/8"  
screw length

**Example:**

THIRD ANGLE  
PROJECTION



Bore	A	B	C	D	E	F	G	H	J	K	Screw Length	
											Standard	Optional
3/4	.69	.50	.28	.44	.25	.19	.19	.88	#10-24	.34	3/4	Up to 2" in 1/8" increments
1-1/8	.81	.63	.34	.56	.31	.25	.25	1.00	5/16-18	.34	3/4	
1-3/8	1.00	.75	.41	.69	.38	.31	.31	1.13	3/8-16	.34	3/4	
1-5/8											3/4	
2												
2-1/2	1.25	1.00	.53	.81	.50	.38	.38	1.38	1/2-13	.47	1	
3												
4												
5												
FH5	2.31	2.00	.66	2.06	1.00	.75	1.00	3.00	5/8-18	.84	1-3/4	
6												
8												



## Male Stud

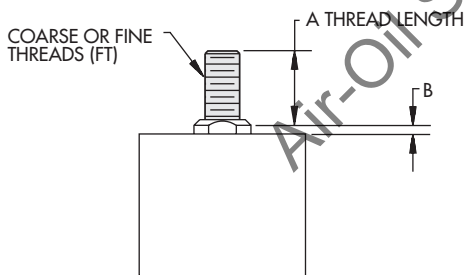

Double ended unit has stud in front end only.

If male stud is desired on *both* ends, specify **MSD** or **FTMSD**.

Male stud thread: Same pitch and diameter as female rod tap

Bore	A		B
	MIN	MAX	
3/4	.38	2	.06
1-1/8	.63		.13
1-3/8	.75		.13
1-5/8			
2			
2-1/2	1.00	2	.13
3			
4			
5			
6			
8			

Coarse thread

**MS**

Fine thread

**FTMS**

**Ordering Suffix:** MS or FTMS

**Material:**

**Length:**

Steel black oxide  
Specify length

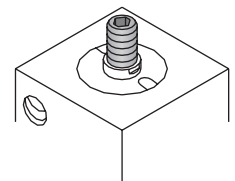

All dimensions are in inches unless  
otherwise noted.



# 3/4" - 8" Bore Options

## Rod Eye

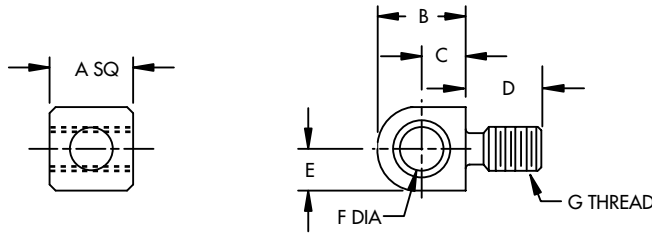

### RE(S)

**Ordering Suffix:** RES - 3/4" bore only

**Ordering Suffix:** RE - 3/4" - 8" bore

**Pressure Rating:** 3/4" - 3" bore: thru 250 PSI

4" bore: thru 200 PSI

5" - 8" bore: thru 200 PSI

(pneumatic only)  
Steel black oxide with sintered bronze bearing

Bore	A	B	C	D	E	F	G	
3/4	.38	.38	.19	.31	.19	.19	#10-24	RES - Short Head Design
	.38	.88	.69	.31	.19	.19	#10-24	RE - Standard Design
1-1/8	.50	.50	.25	.30	.25	.25	5/16-18	
1-3/8								
1-5/8	.63	.63	.31	.42	.31	.31	3/8-18	
2								
2-1/2	1.00	1.00	.50	.88	.50	.50	1/2-13	
3								
4	1.00	1.00	.50	.88	.50	.50	1/2-13	
5								
FH5								
6	1.50	2.50	1.75	.94	.75	.75	5/8-18	
8								

**Material:**

## Rod Wiper

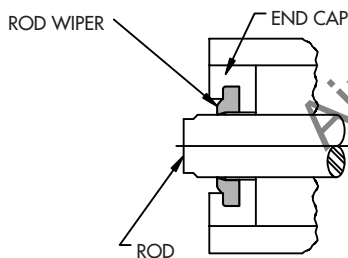

- Husky duty only
- Cylinder length does not increase
- Positioned below cylinder face

### RW

**Ordering Suffix:** RW

**Bore:** 3/4" - 5"

**Duty:** Husky only

**Temperature:** 200°F Max.

**Material:** 3/4" bore: Buna

O-ring

1-1/8" - 5"

bore:

Urethane wiper

All dimensions are in inches unless otherwise noted.

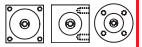

# 3/4" - 8" Bore Options

## Non-Rotating Option

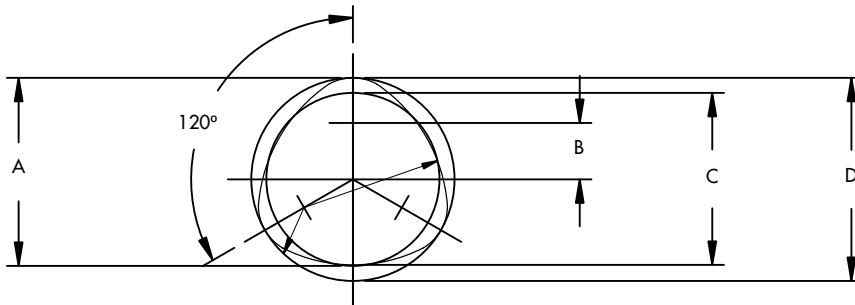

- The non-rotating option requires air line lubrication to prevent bearing and rod wear.
- Female threads not shown for clarity
- Lobe orientation on the rod is random
- Double rod end model has polygon on front end only
- +/- 1° radial movement should be expected, do not torque the bearing

THIRD ANGLE PROJECTION

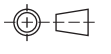

**NR**

- Ordering Suffix:** NR  
**Duty:** Husky recommended  
**Stroke:** Under 1" recommended  
**Service:** Pneumatic only  
**Material:** 303 stainless steel rod, brass, or bronze bearing

Ordering suffix should immediately follow stroke length.  
 Ex: ASFHD118X12NR-RF

Applications		
Example	YES	NO
Basic Orientation	✓	
Workholding Fixtures	✓	
Marking	✓	
Presses	✓	
Parts Ejectors	✓	
Elevators	✓	
Robotic End Effectors	✓	
Custom Escapements	✓	
Clamping	✓	
Long Strokes		X
Pivoting Applications		X
Side Loads		X
Torque Loads		X
Off Center Loads		X

Nominal Sizes (inches)				
Nominal Dia.	A	B	C	D
5/16	.31	.07	.29	.33
1/2	.50	.11	.47	.53
5/8	.63	.15	.59	.67
3/4	.75	.19	.70	.80
1	1.00	.30	.92	1.08

These dimensions are for drafting purposes only

The unique three sided polygon rod often eliminates the need for external alignment devices.



### Basic Workholding Fixtures

- Double rod end will decrease deflection by 35%

### Custom Escapements

- Double acting, independently controlled pneumatic escapements
- Square body design allows close center line positioning

NOTE: For load bearing applications see our Guided Cylinder product line

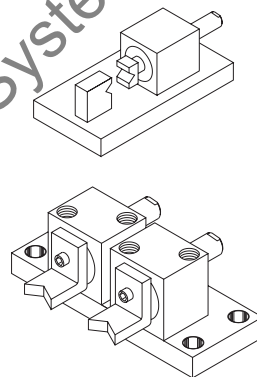

## Fine Thread Rod Tap

<b>Standard Course Thread</b>	#10-24	5/16-18	3/8-16	1/2-13
<b>Optional Fine Thread ("FT")</b>	#10-32	5/16-24	3/8-24	1/2-20

NOTE: FT is standard on 5" full husky through 8" bore.

All dimensions are in inches unless otherwise noted.

**FT**

**Ordering Suffix:** FT

### Modifications Welcome

Special stroke lengths, port orientation, mounting configuration.



# 3/4" - 3" Bore Options

## Short Rear Clevis with Eye Mount

NOTE: Mount can be rotated 90°

THIRD ANGLE PROJECTION

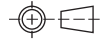

### SRCE

- Ordering Suffix:** SRCE
- Bore:** 3/4" - 3"
- Style:** "S" only
- Rod:** Single only
- Service:** Pneumatic only
- Rating:** 3/4" - 2" bore: thru 250 PSI  
2-1/2" - 3" bore: thru 100 PSI
- Pivot:** 120°
- Material:** Short Rear Clevis: See Below  
Eye Mount: 3/4" bore: Aluminum black anodized with sintered bronze bearing  
1-1/8" - 2-1/2" bore: Aluminum black anodized with steel bearing  
3" bore: Steel black oxide with steel bearing

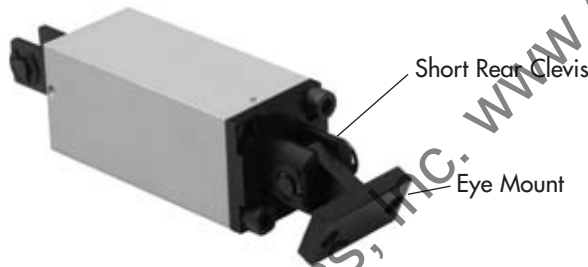
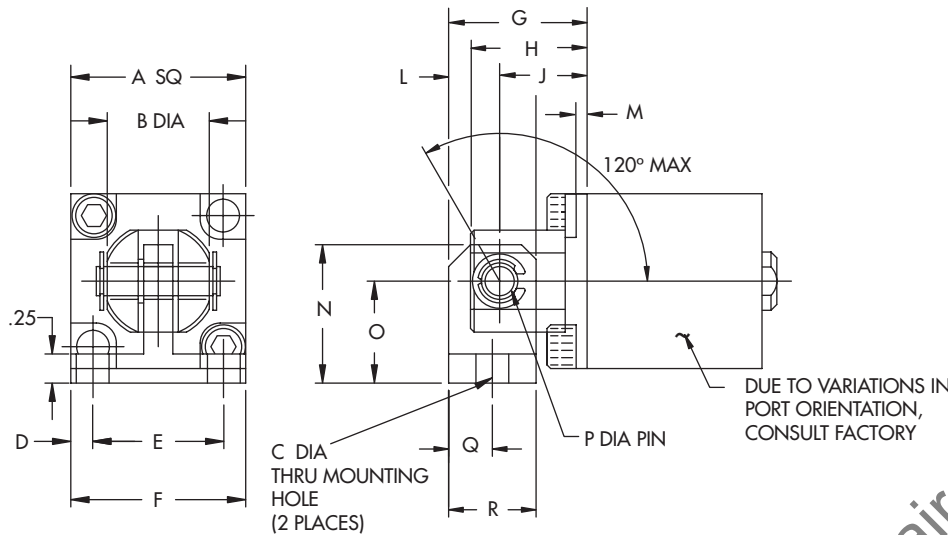

## Short Rear Clevis

NOTE: Mount can be rotated 90°

### SRC

- Ordering Suffix:** SRC
- Bore:** 3/4" - 3"
- Style:** "S" only
- Rod:** Single only
- Material:** Aluminum black anodized with sintered bronze bearings and case hardened pin and clips

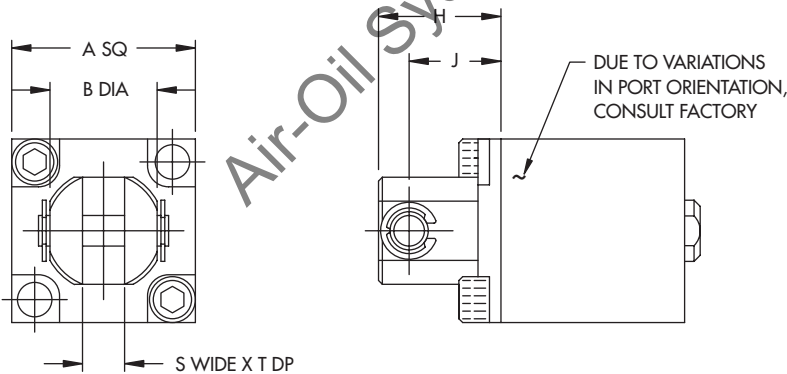

Bore	A	B	C	D	E	F	G	H	J	L	M	N	O	P	Q	R	S	T
3/4	1.25	.69	.28	.19	.88	1.25	1.19	.83	.69	.50	.19	1.00	.75	.19	.38	.75	.28	.56
1-1/8	1.50	.88	.28	.19	1.13	1.50	1.19	1.00	.75	.44	.19	1.19	.88	.25	.38	.75	.34	.69
1-3/8	1.75	1.25	.28	.25	1.50	2.00	1.44	1.19	.81	.63	.19	2.00	1.63	.31	.50	1.00	.41	.88
1-5/8	2.00	1.25	.28	.25	1.50	2.00	1.44	1.19	.81	.63	.19	2.00	1.63	.31	.50	1.00	.41	.88
2	2.50	1.25	.34	.25	1.50	2.00	1.88	1.38	1.00	.88	.31	2.00	1.63	.31	.63	1.25	.41	.94
2-1/2	3.00	2.00	.41	.31	1.38	2.00	2.00	1.56	1.13	.88	.31	2.00	1.63	.38	.63	1.25	.53	1.13
3	3.50	2.00	.41	.31	1.38	2.00	2.25	1.56	1.13	1.13	.31	2.25	1.88	.38	.75	1.50	.53	1.13

All dimensions are in inches unless otherwise noted.



# 3/4" - 3" Bore Options

Style "S"



End Mount

THIRD ANGLE PROJECTION

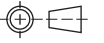

## Flange Mount (Shown as Rear Flange)

### 3/4" - 1-5/8" Bore

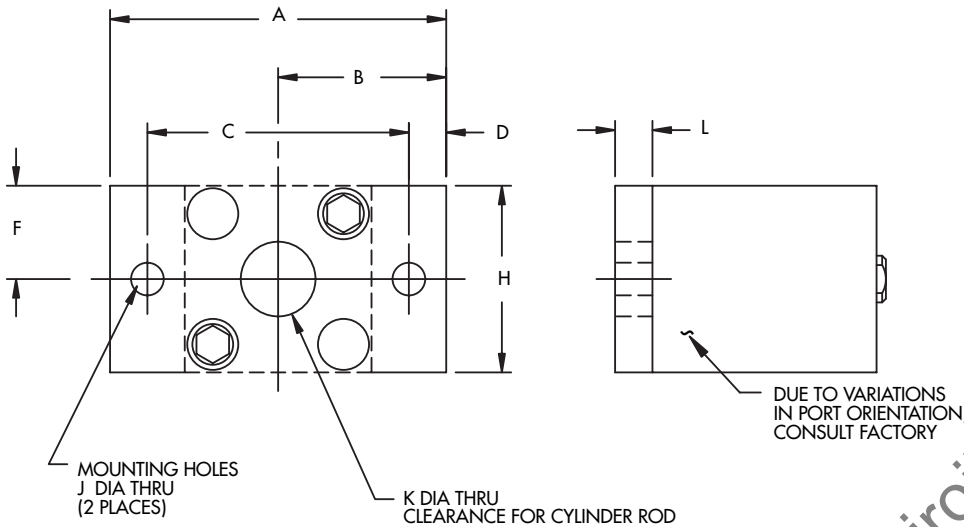

Front Flange

**FF**

or

Rear Flange

**RF**

**Ordering Suffix:** FF or RF  
**Bore:** 3/4" - 3"  
**Style:** "S" only  
**Rotation:** 90°  
**Material:** Aluminum black anodized

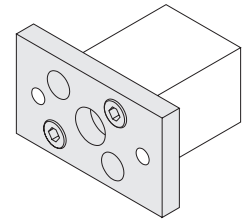

### 2" - 3" Bore

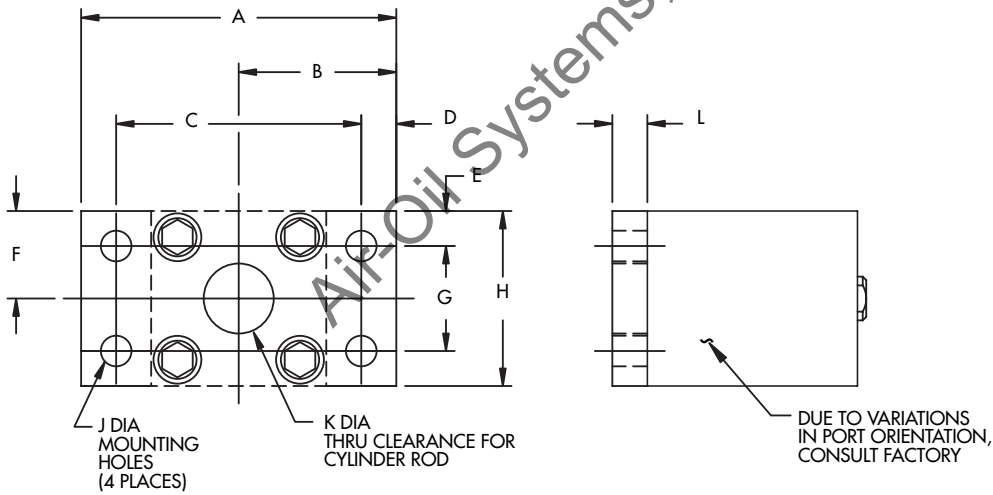

- FF/RF can be rotated 90°

Bore	A	B	C	D	E	F	G	H	J	K	L
3/4	2.25	1.13	1.75	.25	-	.63	-	1.25	.22	.50	.25
1-1/8	2.50	1.25	2.00	.25	-	.75	-	1.50	.22	.75	.25
1-3/8	2.75	1.38	2.25	.25	-	.88	-	1.75	.22	.88	.25
1-5/8	3.00	1.50	2.50	.25	-	1.00	-	2.00	.22	1.13	.25
2	3.50	1.75	3.00	.25	.25	1.25	2.00	2.50	.28	1.38	.38
2-1/2	4.13	2.06	3.50	.31	.31	1.50	2.38	3.00	.34	1.63	.38
3	4.63	2.31	4.00	.31	.31	1.75	2.88	3.50	.34	2.13	.38

All dimensions are in inches unless otherwise noted.



# 3/4" - 3" Bore Options

## End Bracket

THIRD ANGLE PROJECTION

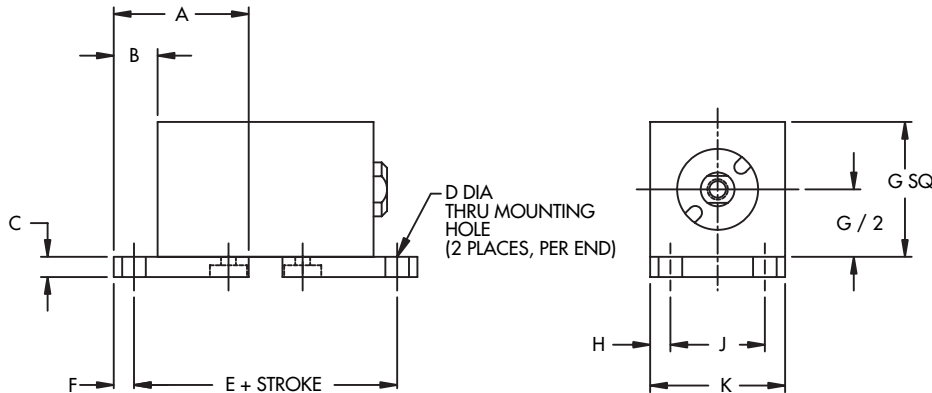
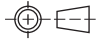

**EB**

**Ordering Suffix:** EB  
**Bore:** 3/4" - 3"  
**Style:** "B" only  
**Material:** Aluminum black anodized

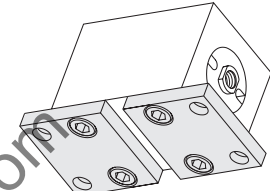

- Number of brackets required:**
- Two mounting holes = 1 bracket
  - Four mounting holes = 2 brackets

Bore	A	B	C	D	E	F	G	H	J	K
3/4	1.13	.38	.19	.22	SEE NOTE BELOW	.19	1.25	.19	.88	1.25
1-1/8	1.13	.38	.19	.22		.19	1.50	.19	1.13	1.50
1-3/8	1.50	.50	.25	.28		.25	1.75	.25	1.25	1.75
1-5/8	1.50	.50	.25	.28		.25	2.00	.25	1.50	2.00
2	1.50	.50	.31	.34		.25	2.50	.25	2.00	2.50
2-1/2	1.50	.50	.31	.34		.25	3.00	.25	2.50	3.00
3	2.00	.63	.38	.41		.31	3.50	.31	2.88	3.50

NOTE: Please consult factory. Body lengths differ depending on duty type, magnetic option, etc.; therefore, this dimension will vary with each cylinder.

## Side Bracket

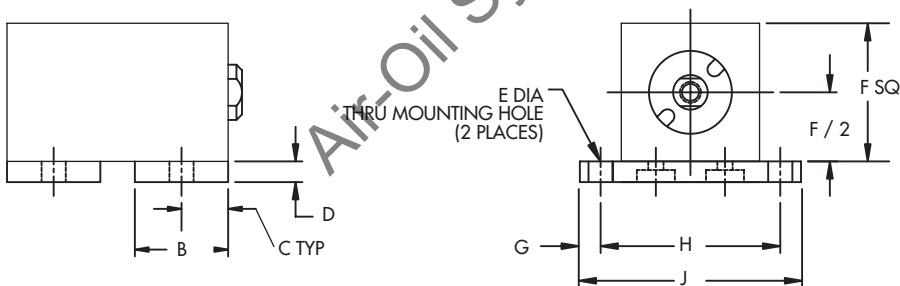

**SB**

**Ordering Suffix:** SB  
**Bore:** 3/4" - 3"  
**Style:** "B" only  
**Material:** Aluminum black anodized

- Number of brackets required:**
- Two mounting holes = 1 bracket
  - Four mounting holes = 2 brackets

Bore	B	C	D	E	F	G	H	J
3/4	.75	.38	.19	.22	1.25	.19	1.88	2.25
1-1/8	.75	.38	.19	.22	1.50	.25	2.00	2.50
1-3/8	1.00	.50	.25	.28	1.75	.25	2.25	2.75
1-5/8	1.00	.50	.25	.28	2.00	.25	2.50	3.00
2	1.00	.50	.31	.34	2.50	.25	3.00	3.50
2-1/2	1.00	.50	.31	.34	3.00	.25	3.50	4.00
3	1.25	.63	.38	.41	3.50	.31	4.13	4.75



All dimensions are in inches unless otherwise noted.



# 3/4" - 8" Bore Options

THIRD ANGLE PROJECTION

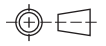

## Flange Mount (Shown as Rear Flange)

### 3/4" - 1-1/8" Bore

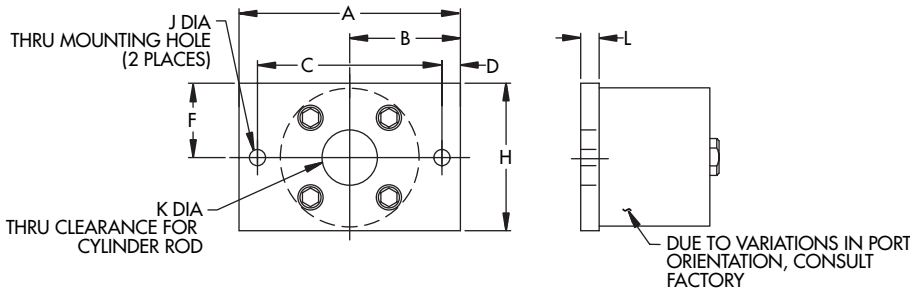

Front Flange

**FF**

or

Rear Flange

**RF**

**Ordering Suffix:** FF or RF  
**Style:** "R" only  
**Material:** 3/4" - 5" bore: Aluminum black anodized  
 6" & 8" bore: Steel black oxide

### 1-3/8" - 4" Bore

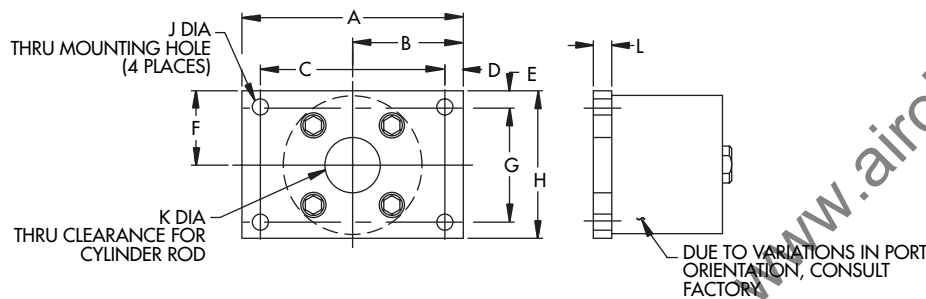

- 3/4" - 6" Flange can be rotated 90°

Bore	A	B	C	D	E	F	G	H	J	K	L
3/4	2.50	1.25	2.00	.25	-	.75	-	1.50	.22	.50	.25
1-1/8	3.00	1.50	2.50	.25	-	1.00	-	2.00	.22	.75	.25
1-3/8	2.38	1.19	1.94	.22	.22	1.00	1.56	2.00	.22	.88	.25
1-5/8	2.50	1.25	2.00	.25	.25	1.25	2.00	2.50	.22	1.13	.25
2	3.00	1.50	2.50	.25	.25	1.50	2.50	3.00	.28	1.38	.38
2-1/2	3.50	1.75	2.88	.31	.31	1.75	2.88	3.50	.28	1.63	.38
3	4.00	2.00	3.38	.31	.31	2.00	3.38	4.00	.34	2.13	.38
4	5.00	2.50	4.25	.38	.38	2.50	4.25	5.00	.34	2.13	.50

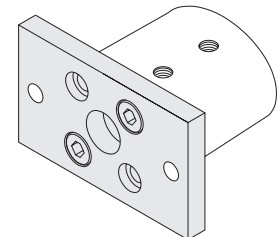

### 5" - 8" Bore

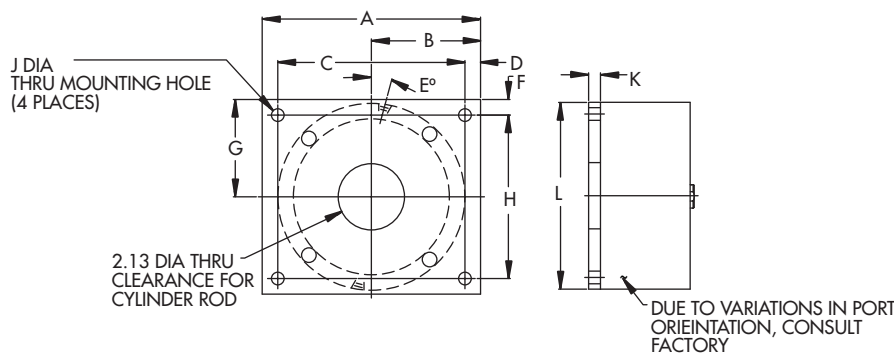

- 8" Flange can be rotated 60°

Bore	A	B	C	D	E°	F	G	H	J	K	L
5	7.00	3.50	6.00	.50	0°	.50	3.00	5.00	.41	.38	6.00
6	7.00	3.50	6.00	.50	8°	.50	3.00	5.00	.41	.38	6.00
8	9.50	4.75	8.00	.75	15°	.75	4.00	6.50	.53	.50	8.00

All dimensions are in inches unless otherwise noted.



# 3/4" - 8" Bore Options

## Pivot Shaft

### 3/4" - 4" Bore

THIRD ANGLE PROJECTION

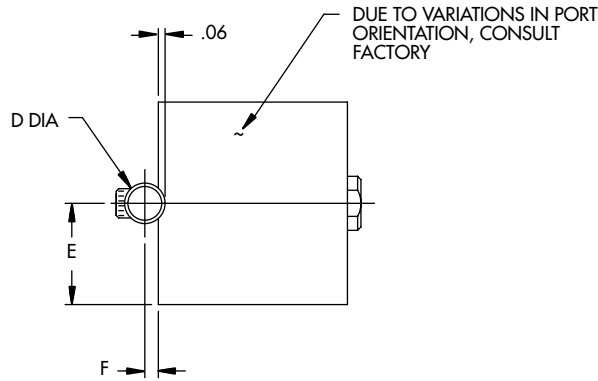
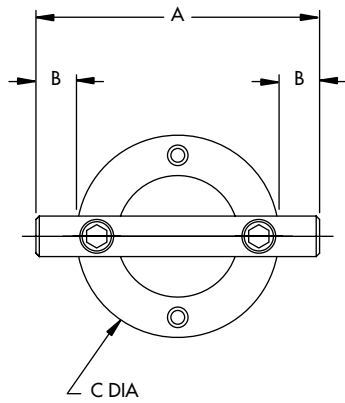
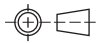

**PS**

**Ordering Suffix:** PS  
**Rod:** Single only  
**Style:** "R" only  
**Material:** Steel black oxide shaft. 5" - 8" bore with aluminum mounting bracket.

Bore	A	B	C	D	E	F
3/4	2.25	.34	1.50	.38	.75	.13
1-1/8	2.63	.34	1.88	.38	.94	.13
1-3/8	2.88	.34	2.13	.38	1.06	.13
1-5/8	3.13	.34	2.38	.38	1.19	.13
2	4.25	.59	3.00	.50	1.50	.19
2-1/2	4.75	.59	3.50	.50	1.75	.19
3	5.25	.59	4.00	.63	2.00	.25
4	6.25	.59	5.00	.63	2.50	.25

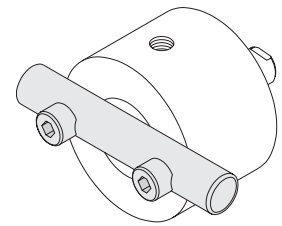

### 5" - 8" Bore

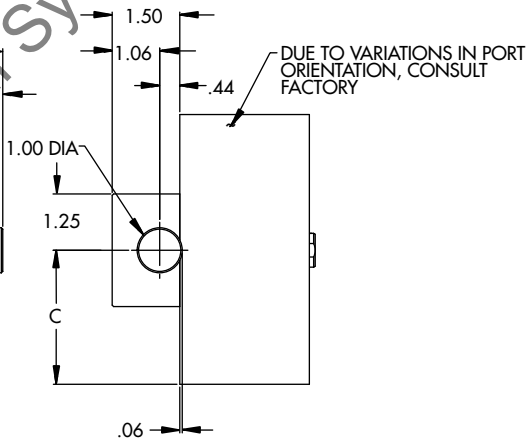
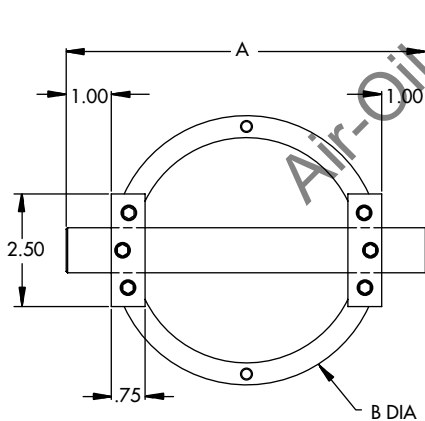

Bore	A	B	C
5	8.00	6.00	3.00
6	9.00	7.00	3.50
8	11.00	9.00	4.50

All dimensions are in inches unless otherwise noted.



# 3/4" - 8" Bore Options

## Short Pivot Mount

### 3/4" - 4" Bore

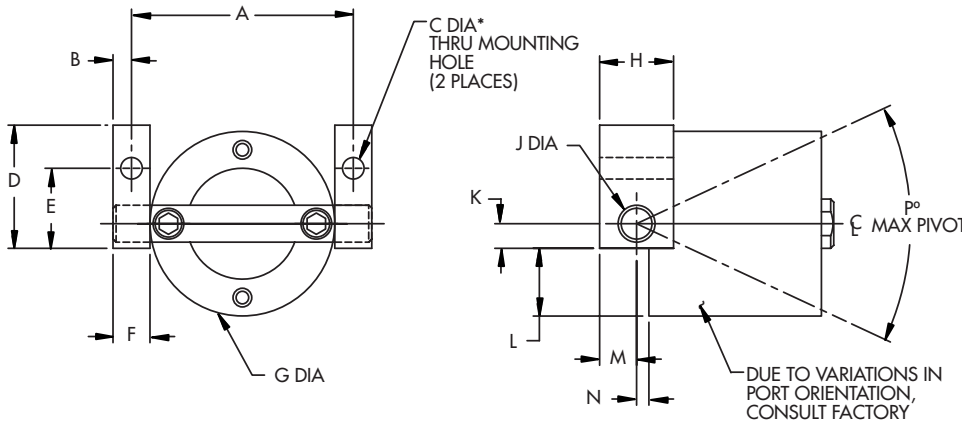

THIRD ANGLE PROJECTION

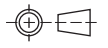

**SP**

**Ordering Suffix:** SP

**Rod:** Single only

**Style:** "R" only

**Pivot:** See table below  
Steel black oxide pivot shaft, aluminum black anodized bracket with sintered bronze bearings

**Material:**

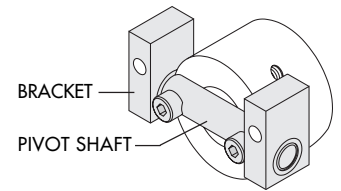

\*4" bore = 4 mounting holes. Consult factory for mounting hole locations.

Bore	A	B	C	D	E	F	G	H	J	K	L	M	N	P°
3/4	1.88	.19	.22	1.25	.81	.38	1.50	.75	.38	.38	.75	.38	.13	75°
1-1/8	2.25	.19	.22	1.25	.81	.38	1.88	.75	.38	.38	.56	.38	.13	60°
1-3/8	2.50	.19	.22	1.25	.81	.38	2.13	.75	.38	.38	.69	.38	.13	55°
1-5/8	2.75	.19	.22	1.25	.81	.38	2.38	.75	.38	.38	.81	.38	.13	50°
2	3.63	.31	.41	2.00	1.19	.63	3.00	1.25	.50	.50	1.00	.63	.19	60°
2-1/2	4.13	.31	.41	2.00	1.19	.63	3.50	1.25	.50	.50	1.25	.63	.19	50°
3	4.63	.31	.41	2.50	1.63	.63	4.00	1.50	.63	.75	1.25	.75	.25	45°
4	5.75	.38	.41	3.50	2.13	.75	5.00	1.50	.63	1.13	1.38	.88	.25	35°

### 5" - 8" Bore

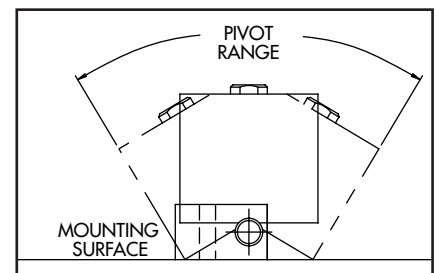
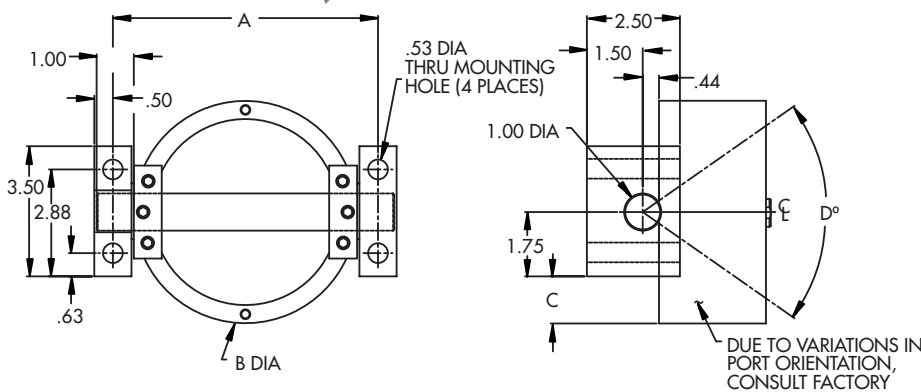

Bore	A	B	C	D°
5	7.25	6.00	1.25	55°
6	8.25	7.00	1.75	45°
8	10.25	9.00	2.75	35°

All dimensions are in inches unless otherwise noted.

Style "R"



End Mount

# 3/4" - 4" Bore Options

## Long Pivot Mount

THIRD ANGLE PROJECTION

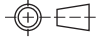

**LP**

**Ordering Suffix:** LP  
**Bore:** 3/4" - 4"  
**Rod:** Single only  
**Style:** "R" only  
**Pivot:** 180°  
**Material:** Steel black oxide pivot shaft with aluminum black anodized brackets and sintered bronze bearings

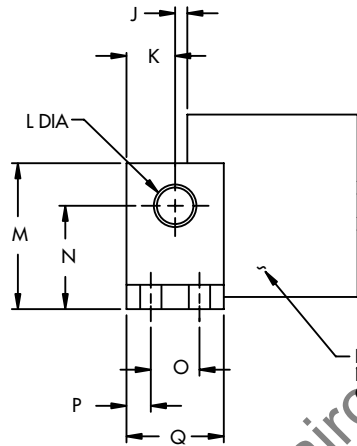
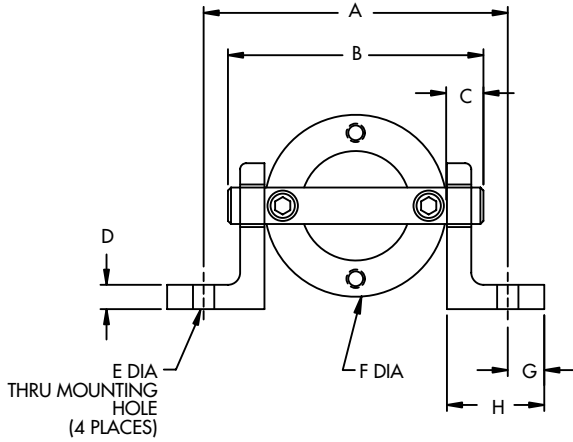

DUE TO VARIATIONS IN PORT ORIENTATION, CONSULT FACTORY

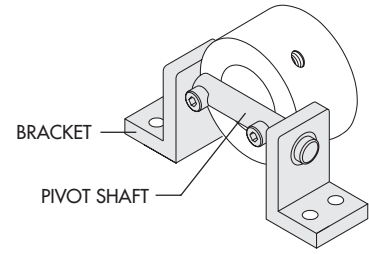

Bore	A	B	C	D	E	F	G	H	J	K	L	M	N	O	P	Q
3/4	2.75	2.25	.34	.25	.22	1.50	.38	1.00	.13	.50	.38	1.50	1.06	.50	.25	1.00
1-1/8	3.13	2.63	.34	.25	.22	1.88	.38	1.00	.13	.50	.38	1.50	1.06	.50	.25	1.00
1-3/8	3.38	2.88	.34	.25	.22	2.13	.38	1.00	.13	.50	.38	2.00	1.25	.50	.25	1.00
1-5/8	4.38	3.13	.34	.38	.28	2.38	.50	1.50	.13	.50	.38	2.50	1.63	.50	.25	1.00
2	5.00	4.25	.59	.38	.28	3.00	.50	1.50	.19	.50	.50	2.50	1.63	.50	.25	1.00
2-1/2	5.25	4.75	.59	.38	.34	3.50	.50	1.38	.19	.75	.50	3.00	2.13	.75	.38	1.50
3	5.75	5.25	.59	.38	.34	4.00	.50	1.38	.25	.75	.63	3.00	2.13	.75	.38	1.50
4	7.25	6.25	.59	.50	.41	5.00	.63	1.75	.25	1.00	.63	3.50	2.63	1.00	.50	2.00

All dimensions are in inches unless otherwise noted.



# 3/4" - 5" Bore Options

THIRD ANGLE PROJECTION

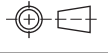

## Nose Mount

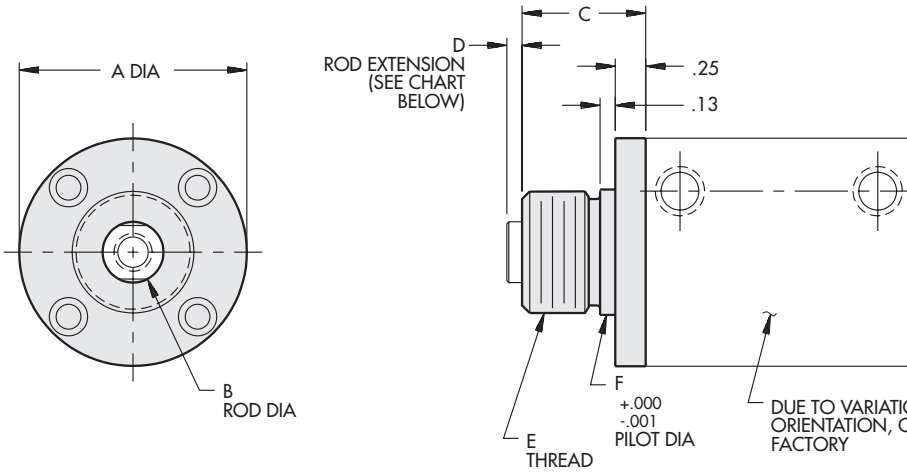

### NM

**Ordering Suffix:** NM  
**Bore:** 3/4" - 5"  
**Duty:** Standard only  
**Style:** "R" only  
**Material:** 3/4" bore: Brass  
 1-1/8" - 5" bore: Aluminum black anodized with sintered bronze bearing



Bore	A	B	C	D	E	F
3/4	1.50	.31	1.00	See Rod Extension Chart Below	3/4-16 x 5/8	.750
1-1/8	1.88	.50	1.00		1-14 x 5/8	.999
1-3/8	2.13	.63	1.00		1-1/4-12 x 5/8	1.249
1-5/8	2.38	.63	1.00		1-1/4-12 x 5/8	1.249
2	3.00	.63	1.00		1-1/4-12 x 5/8	1.249
2-1/2	3.50	.75	1.50		1-1/2-12 x 1-1/8	1.499
3	4.00	.75	1.50		1-1/2-12 x 1-1/8	1.499
4	5.00	.75	1.50		2-12 x 1-1/8	1.999
5	6.00	.75	1.50		2-12 x 1-1/8	1.999

### Optional Jam Nut (order separately)

Part No.	A	B	C	D
34NT	1.13	1.27	3/4-16	.19
1NT	1.50	1.69	1-14	.19
114NT	1.88	2.11	1-1/4-12	.25
112NT	2.25	2.53	1-1/2-12	.25
2NT	3.00	3.39	2-12	.25

### "D" - Rod Extension Chart

Bore	Piston Type	Stroke														
		1/8	1/4	3/8	1/2	5/8	3/4	7/8	1	1-1/8	1-1/4	1-3/8	1-1/2	1-5/8	1-3/4	1-7/8 & up
3/4" thru 2"	Non-magnetic	STD+.13	STD	STD+.13	STD	STD+.13	STD	STD+.25	STD	STD	STD+.25	STD	STD	STD	STD+.25	STD
	STD+.25															
2-1/2" thru 5"	Non-magnetic	STD+.13	STD	STD+.13	STD+.25	STD	STD+.13	STD+.25	STD	STD	STD+.25	STD	STD	STD	STD+.25	STD
	STD+.25															

Chart STD = .06 on 3/4" bore  
 = .13 on 1-1/8" bore and longer

All dimensions are in inches unless otherwise noted.

# Sensors

## Standard Limit Sensors

- Low Cost and Compact® size
- Dual LED indicators for power and signal
- Circuit protection for surge and polarity
- High-flex robotic grade cable with 4,8mm (3/16") bend radius. 105 strand primaries.
- CE compliant / IP67 and NEMA 6P rated
- 100% solid state device for maximum life
- 3 cord options

(Shown with Quick Disconnect Option)



### 3 Prong Plug

#WSKLP, #WSCLP, #WSKLP3, #WSCLP3

Part No.		Sensor Type (Wiring diagrams and definitions on page 88)	Cord Types		
			Quick Disconnect	1 Meter	3 Meter
Sinking	WSKL	NPN		✓	
	WSKLP		✓*		
	WSKL-3				✓
	WSKLP3		✓*		
Sourcing	WSCL	PNP		✓	
	WSCLP		✓*		
	WSCL-3				✓
	WSCLP3		✓*		

\*Mating 3 socket receptacle available, part # R3  
"3" denotes 3 meter cable

**WS\_LP**

**WS\_LPS**

## Optional Quick Disconnect Sensor Cable with threaded, sealed connectors

Part Number - Specify **K** or **C**

### Plug - 3 Prong

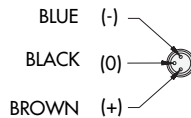
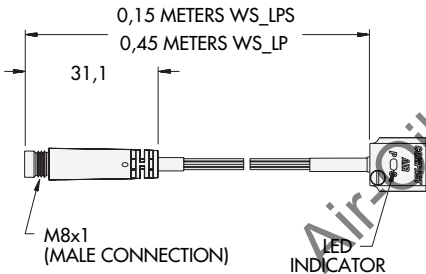

### 3 Socket Mating Cable

For use with:  
#WSKLP, #WSCLP, #WSKLP3, #WSCLP3,



Part Number
R3
R5
R7

Sold Separately

### Receptacle - 3 Socket

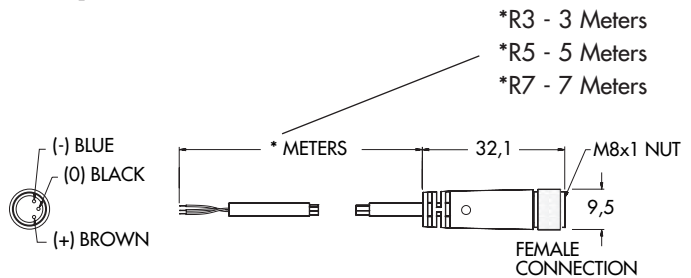



## Comtronic® Sensors Dimensional Information

Must specify 'K' (sinking) or 'C' (sourcing) when ordering

Part Number - Specify K or C

**WS\_L      WS\_L-3**

"3" denotes 3 meter cable

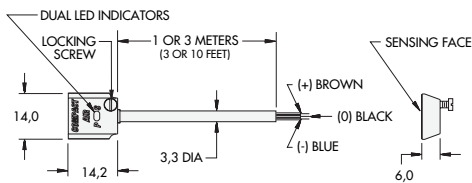

**Part No. WSKL-3** - Sinking output with 3 meter cable.



Specifications		
Parameters	Comtronic® Standard Limit Sensors	
	NPN (sinking)	PNP (sourcing)
Part Number	WSKL, WSKL-3, WSKLP, WSKLPS	WSCL, WSCL-3, WSCLP, WSCLPS
Operating Voltage	5-24 VDC	
Current Consumption On	16mA (at 24V)	14mA (at 24V)
Off	7mA (at 24V)	7mA (at 24V)
Switching Current	100mA Max	
Voltage Drop	1.5 V Max @ 100mA	
Operating Frequency	1 KHz Max	
Switch Logic	Sinking, Normally Open	Sourcing, Normally Open
LED Function Green	Power On	
Red	Switch Active (Magnet Present)	
Operating Temperature	0°C to 70°C	
Circuit Protection	Reverse Polarity / Surge Absorber	
Environmental Certifications	IEC standard IP67, NEMA 6P	
Wire Type	High flex, 24 AWG / 105 strand primary	
Housing Material	Zinc diecast	
Housing Color Code	Black	Silver
Shock Resistance	30G Max	
Vibration Strength	9G Max	

## Wiring Diagrams and Definitions

For units with flying leads

### NPN Output Sinking (K)

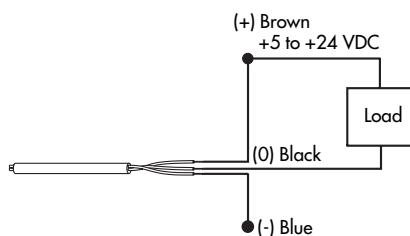

- Ideal for complex controls utilizing multiple power supplies.

A "sinking" output sensor complete a circuit by connecting the load to ground. Sinking output sensors in a sequence can have different supply voltages. The ground is their common factor.

### PNP Output Sourcing (C)

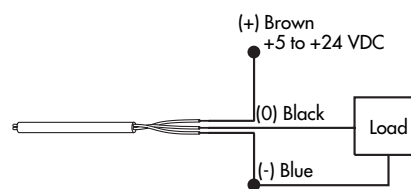

- Ideal for single power supply applications.

A "sourcing" output sensor completes a circuit by connecting the load to the supply current. All sourcing output sensors must have the same supply voltage.

# Rod End Alignment Coupler Inch Sizes

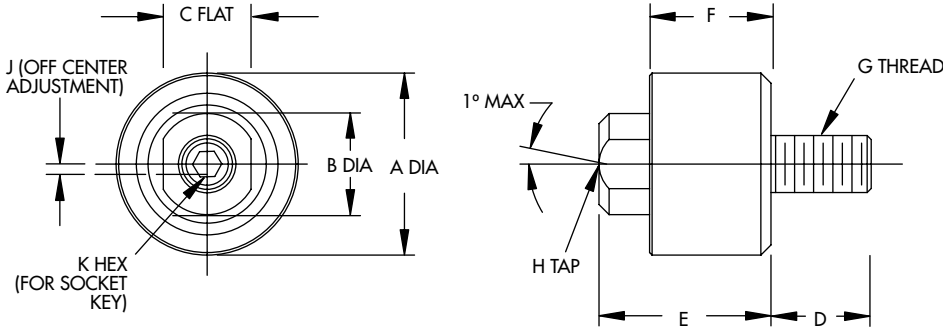

**Material:** Hardened steel  
**Finish:** Black Oxide Finish  
**Maximum Temperature Rating:** 200°F (93.3°C)

NOTE: Do not use alignment couplers on pivoting applications.

**Sold separately - Not attached to the cylinder.**

All dimensions are in inches.

Applicable Compact Air Cylinders	Screw Size	Part Number	Male Thread	Female Thread	A	B	C	D	E	F	G Male Thread	H Female Thread x Depth	J	K	Unit Weight (oz.)	Axial Load Ratings (lbs.)
1/2"	# 8	ACCC8	Coarse		9/16	1/4	7/32	5/16	7/16	11/32	# 8-32	# 8-32 x 1/4	1/64	5/64	0.4	180
3/4"	# 10	ACCC10	Coarse		9/16	5/16	1/4	11/32	9/16	13/32	# 10-24	# 10-24 x 5/16	1/64	3/32	0.5	180
		ACCF10	Coarse	Fine							# 10-24	# 10-32 x 5/16				
		ACFF10	Fine								# 10-32	# 10-32 x 5/16				
		ACFC10	Fine	Coarse							# 10-32	# 10-24 x 5/16				
-	1/4"	ACCC14	Coarse		15/16	1/2	7/16	13/32	13/16	9/16	1/4-20	1/4-20 x 1/2	1/32	1/8	1.6	450
		ACCF14	Coarse	Fine							1/4-20	1/4-28 x 1/2				
1-1/8"	5/16"	ACCC516	Coarse		15/16	1/2	7/16	11/16	13/16	9/16	5/16-18	5/16-18 x 5/8	1/64	5/32	1.6	580
		ACCF516	Coarse	Fine							5/16-18	5/16-24 x 5/8				
		ACFF516	Fine								5/16-24	5/16-24 x 5/8				
		ACFC516	Fine	Coarse							5/16-24	5/16-18 x 5/8				
1-1/8"	5/16"	ACCC516L	Coarse		1-1/8	5/8	9/16	9/16	1-1/32	3/4	5/16-18	5/16-18 x 5/8	1/32	5/32	3.2	580
		ACCF516L	Coarse	Fine							5/16-18	5/16-24 x 5/8				
		ACFF516L	Fine								5/16-24	5/16-24 x 5/8				
		ACFC516L	Fine	Coarse							5/16-24	5/16-18 x 5/8				
1-3/8" 1-5/8" 2.0"	3/8"	ACCC38	Coarse		1-1/8	5/8	9/16	19/32	1-1/32	3/4	3/8-16	3/8-16 x 5/8	1/32	3/16	3.2	830
		ACCF38	Coarse	Fine							3/8-16	3/8-24 x 5/8				
		ACFF38	Fine								3/8-24	3/8-24 x 5/8				
		ACFC38	Fine	Coarse							3/8-24	3/8-16 x 5/8				
2-1/2" 3.0" 4.0" 5.0"	7/16"	ACCF716	Coarse	Fine	1-9/16	3/4	11/16	3/4	1-3/8	1-1/8	1/2-13	7/16-20 x 13/16	1/16	1/4	8.8	1690
		ACFF716	Fine								1/2-20	7/16-20 x 13/16				
	1/2"	ACCC12	Coarse		1-9/16	3/4	11/16	3/4	1-3/8	1-1/8	1/2-13	1/2-13 x 13/16	1/16	1/4	8.8	1690
		ACCF12	Coarse	Fine							1/2-13	1/2-20 x 13/16				
		ACFF12	Fine								1/2-20	1/2-20 x 13/16				
		ACFC12	Fine	Coarse							1/2-20	1/2-13 x 13/16				
6.0" 8.0"	5/8"	ACCC58	Coarse		2-1/4	1.0	15/16	15/16	1-3/4	1-1/2	5/8-11	5/8-11 x 1.0	1/16	5/16	24.0	3220
		ACCF58	Coarse	Fine							5/8-11	5/8-18 x 1.0				
		ACFF58	Fine								5/8-18	5/8-18 x 1.0				
		ACFC58	Fine	Coarse							5/8-18	5/8-11 x 1.0				

# Rod End Alignment Coupler Combination Sizes

FIRST ANGLE PROJECTION

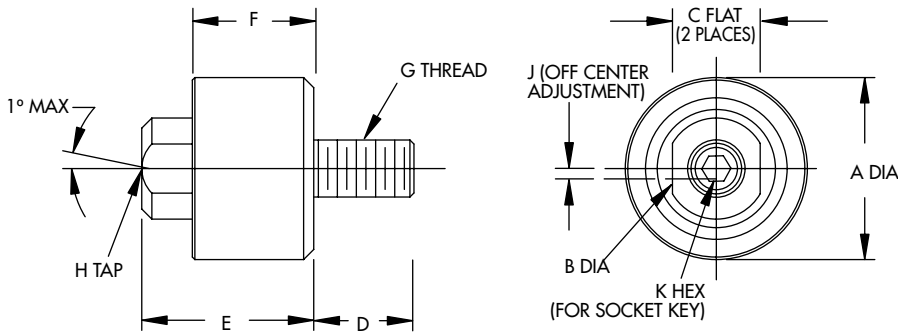
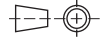

**Material:** Hardened steel  
**Finish:** Black Oxide Finish  
**Maximum Temperature Rating:** 200°F (93.3°C)

NOTE: Do not use alignment couplers on pivoting applications.

**Sold separately - Not attached to the cylinder.**

All dimensions are in millimeters except where noted.

Applicable Compact Air Cylinder	Part Number	A	B	C	D	E	F	G Male Thread	H Female Thread X Depth	J	K mm (Inch)	Unit Weight (Grams)	Axial Load Rating (N)
1/2" & 10mm	WACC8-M4	14,3	6,1	5,0	8,0	11,2	8,7	#8-32	M4x0,7 x 6	0,4	1,98 (5/64)	11,4	815
10mm	WACM4-C8	14,0	6,35	5,6	6,0	12,5	10,0	M4x0,7	#8-32 x 1/4		2,5 (.098)		
3/4"	WACC10-M5	14,3	7,6	7,0	8,7	14,5	10,3	#10-24	M5x0,8 x 8	0,4	2,38 (3/32)	14,2	815
	WACF10-M5							#10-32					
20mm 25mm	WACM5-C10	14,0	7,9	6,35	8,0	15,2	11,0	M5x0,8	#10-24 x 5/16	0,4	3,0 (.118)		
	WACM5-F10								#10-32 x 5/16				
-	WACC14-M6	23,8	12,4	10,0	10,3	20,8	14,3	1/4-20	M6x1 x 13	0,8	3,18 (1/8)	45,4	2045
	WACM6-C14	24,0	12,7	11,1	9,7	21,5	15,0	M6x1	1/4-20 x 1/2				
	WACM6-F14								1/4-28 x 1/2				
1-1/8"	WACC516-M8	23,8	12,4	10,0	17,5	20,8	14,3	5/16-18	M8x1,25 x 13	0,4	3,97 (5/32)	45,4	2580
	WACF516-M8							5/16-24					
-	WACM8-C516	24,0	12,7	11,1	11,7	22,5	16,0	M8x1,25	5/16-18 x 5/8	0,4	5,0 (.197)		
	WACM8-F516								5/16-24 x 5/8				
1-3/8 1-5/8 2.0"	WACC38-M10	28,6	15,6	13,0	15,1	26,3	19,1	3/8-16	M10x1,5 x 15	0,8	4,76 (3/16)	90,7	3700
	WACF38-M10							3/8-24					
-	WACM10-C38	28,0	15,9	14,3	16	26,5	20,0	M10x1,5	3/8-16 x 5/8	0,8	7,0 (.276)		
	WACM10-F38								3/8-24 x 5/8				
2-1/2 3.0 4.0 5.0"	WACM12-F716	39,0	19,1	17,5	17,9	36,5	30,0	M12x1,75	7/16-20 x 13/16	1,6	8,0 (.315)	250,0	7540
	WACC12-M12	39,7	18,8	16,0	19,1	35,1	28,6	1/2-13	M12x1,75 x 19				
	WACF12-M12							1/2-20					
	WACM12-C12	39,0	19,1	17,5	17,9	36,5	30,0	M12x1,75	1/2-13 x 13/16				
	WACM12-F12								1/2-20 x 13/16				

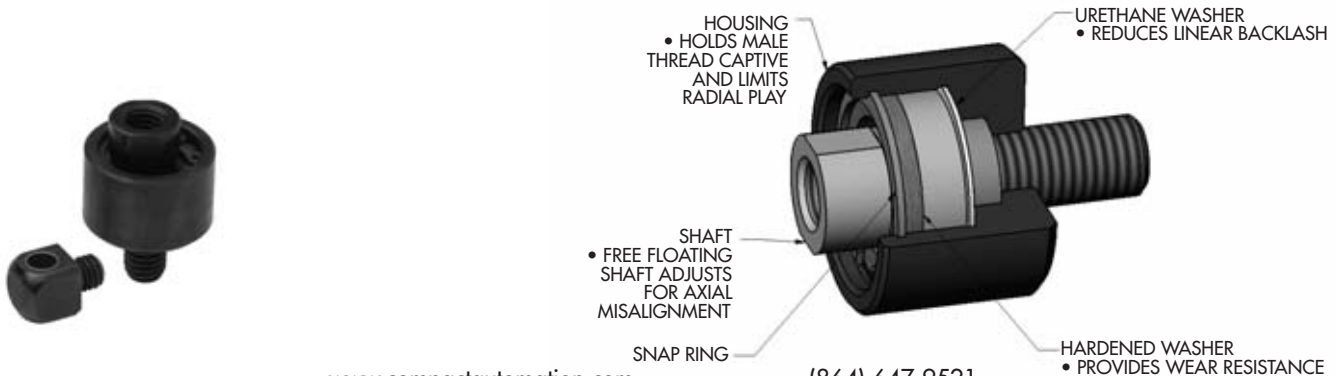

# Flow Controls

## Unique Inch to Metric Combinations

- Inch Sizes: #10-32, 1/8NPTF, 1/4NPTF
- Metric Sizes: M5, G1/8, G1/4
- #10-32 valves available with a space saving integral barb for 1/8" I.D. tubing.
- Meter Out style valves can be factory installed to your Compact Automation cylinders, guided cylinders, gripper, etc... at no extra charge. See Factory Installed below.

### 3 Flow Paths

#### Style "MO" Meter Out

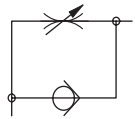

- Metered Output
- Free Flow Input



#### Style "MI" Meter In

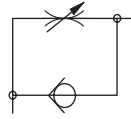

- Metered Input
- Free Flow Output



#### Style "NV" Needle Valve Meter Both Ways



- Metered Input
- Metered Output

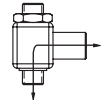

### Precision Control

- A unique needle design minimizes turbulence and improves flow control ability.
- A super fine pitch needle thread provides the finest adjustment available.
- Captive needle cannot be adjusted out of the housing.

Sizes	Needle Pitch	Number of Turns
# 10-32	80 TPI	6
M5 x .8	.32mm	
1/8NPTF	60 TPI	8
G1/8	.42mm	
1/4NPTF	56 TPI	8
G1/4	.45mm	

### Model Numbers\*

Port Thread	"MO" Color Code: Black			"MI" Color Code: Red			"NV" Color Code: Silver		
	Model #	Male Thread	Female Thread	Model #	Male Thread	Female Thread	Model #	Male Thread	Female Thread
# 10-32 M5	MO10	# 10-32	# 10-32	MI10	# 10-32	# 10-32	NV10	# 10-32	# 10-32
	MO5	M5	M5	MI5	M5	M5	NV5	M5	M5
	MO10-5	# 10-32	M5	MI10-5	# 10-32	M5	NV10-5	# 10-32	M5
	MO10B	M5	# 10-32	MI5-10	M5	# 10-32	NV5-10	M5	# 10-32
	MO10B	# 10-32	1/8" barb	MI10B	# 10-32	1/8" barb	NV10B	# 10-32	1/8" barb
	MO5B	M5	1/8" barb	MI5B	M5	1/8" barb	NV5B	M5	1/8" barb
1/8-27NPTF G1/8	MO18	1/8NPTF	1/8NPTF	MI18	1/8NPTF	1/8NPTF	NV18	1/8NPTF	1/8NPTF
	MOG18	G1/8	G1/8	MIG18	G1/8	G1/8	NVG18	G1/8	G1/8
	MO18-G18	1/8NPTF	G1/8	MI18-G18	1/8NPTF	G1/8	NV18-G18	1/8NPTF	G1/8
	MOG18-18	G1/8	1/8NPTF	MIG18-18	G1/8	1/8NPTF	NVG18-18	G1/8	1/8NPTF
1/4-18NPTF G1/4	MO14	1/4NPTF	1/4NPTF	MI14	1/4NPTF	1/4NPTF	NV14	1/4NPTF	1/4NPTF
	MOG14	G1/4	G1/4	MIG14	G1/4	G1/4	NVG14	G1/4	G1/4
	MO14-G14	1/4NPTF	G1/4	MI14-G14	1/4NPTF	G1/4	NV14-G14	1/4NPTF	G1/4
	MOG14-14	G1/4	1/4NPTF	MIG14-14	G1/4	1/4NPTF	NVG14-14	G1/4	1/4NPTF

NPTF = National Pipe Thread Dry Seal (1/8NPTF and 1/4 NPTF)

"G" = BSPP British Standard Pipe Parallel (G1/8 and G1/4)

1/8" Barb is for 1/8" ID polyurethane or vinyl tubing

\* = All model numbers are available with the Knob Option, add suffix "K" to the end of the part number.

### Factory Installed

Compact Automation Products will factory install any "MO" model flow control at no charge.

How to Order:

- 1.) Verify "MO" model number required from the chart above.
- 2.) Choose factory installation: "PC1" Head end only, "PC2" Cap end only, "PC 3" Head and cap end
- 3.) Remove "MO" from model number and add "PC" option to the end

Factory Installed part number example: G18-18PC3

Flow control required: MOG18-18  
Install at: head and cap end PC3  
(Remove MO add PC3 to end)

Specify our unique Inch to Metric or Metric to Inch combination flow controls factory installed to convert cylinder ports.

For example, metric cylinder part number WS25x25 - G18-18PC3 would place two metered output flow controls on the cylinder and allow for the use of 1/8-27 NPTF fittings.

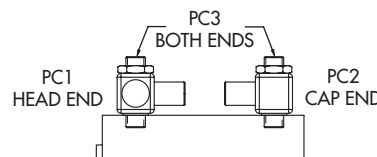

## Dimension Information Minimum body length for two port controls - 7/8"

Inch Version

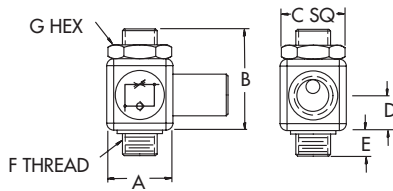

Barb Fitting for #10-32 or M5 only

#10-32 or M5 Male to Barb for 1/8" I.D. tubing

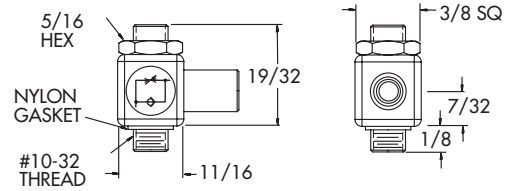

Model #	A	B	C	D	E	F	G
MO10 MI10 NV10	5/8	19/32	13/8	7/32	1/8	# 10-32	5/16
MO18 MI18 NV18	1.0	1.9	9/16	.40	.18	1/8-27 NPTF	9/16
MO14 MI14 NV14	1-1/8	1.2	11/16	.50	.23	1/4-18 NPTF	11/16

Model Number Examples	MO10B	MI10B	NV10B
	MO5B	MI5B	NV5B

Knob Option Available with any valve

Inch Version

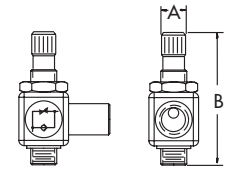

Combination

### Important Note

The combination units with Inch and Metric threads are modular versions of both drawings.

Model Number	MO10K MI10K NV10K	MO18K MI18K NV18K	MO14K MI14K NV14K
A	5/32	15/64	19/64
B (max.)	29/32	1-5/16	1-5/8

## Flow Chart

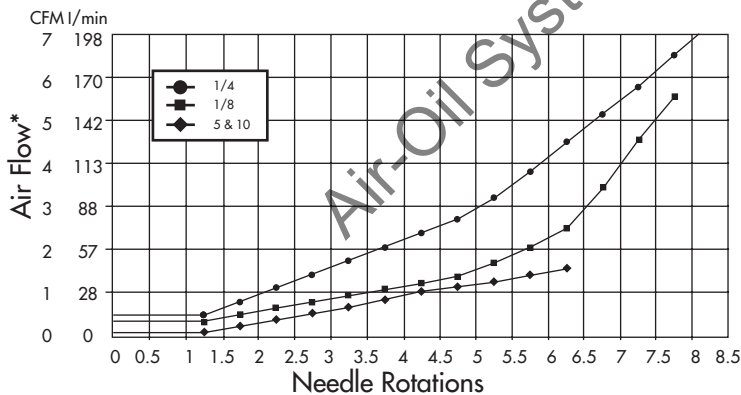

## Cv Factor

Cv = Volume of water in gallons at 60°F (15°C) that will flow per minute through the valve with a pressure differential of 1 PSI across the valve.

Style	Flow Direction (Fully open)	# 10-32 M5	1/8-27 G1/8	1/4-18 G1/4
MO	Free Cv	.08	.25	.42
	Metered Cv	.05	.20	.38
MI	Free Cv	.07	.23	.40
	Metered Cv	.06	.22	.39
NV	Metered Cv	.05	.24	.38

\* At 60 PSI (4.1 BAR) and 60°F (15°C)

## Materials and Technical Data

Size	Housing	Inner Housing	Needle	Seals	Pressure Ratings	Captive Needle	360° Swivel	Gasket Material
M5 # 10-32	Nickel Plated Brass	Nickel Plated Brass	Stainless Steel	Buna-N 0°F to 200°F -15°C to 90°C	0 to 175 PSI 0 to 12 BAR	Yes	Yes- Prior to tightening 1/8NPTF and 1/4NPTF swivel after mounting	Nylon 0°F to 200°F -15°C to 90°C
1/8 and 1/4	Anodized Aluminum							

# Reverse Assembly

Simple solution to a mounting or porting interference. Compact® cylinders are symmetrical and easily assembled in reverse. When specifying 'RA' the mounting and porting orientations will change; see examples below.

This option is *not* applicable to Magnetic Piston cylinders.

## Reverse Assembly

Ordering  
Suffix

**RA**

### Example 3/4" Bore Short Stroke

#### Standard Assembly

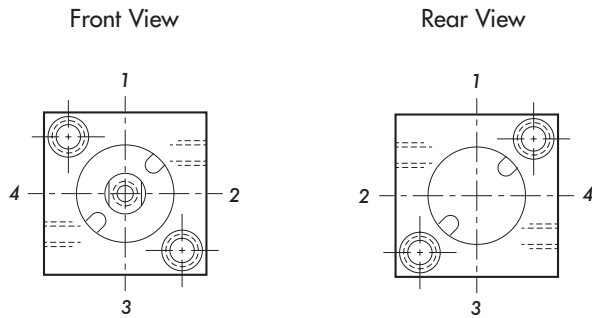

#### Reverse Assembly

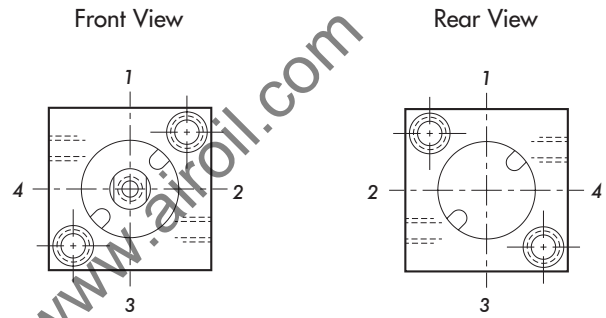

Orientation of porting and mounting change

### Example 3/4" Bore Long Stroke

#### Standard Assembly

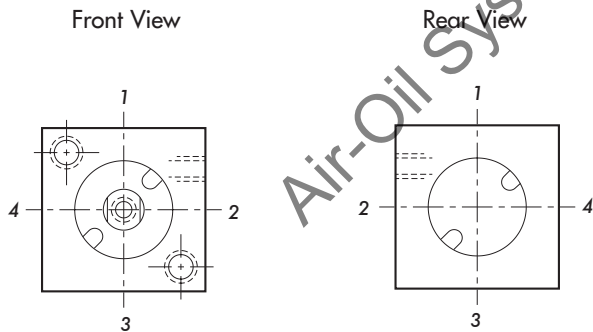

#### Reverse Assembly

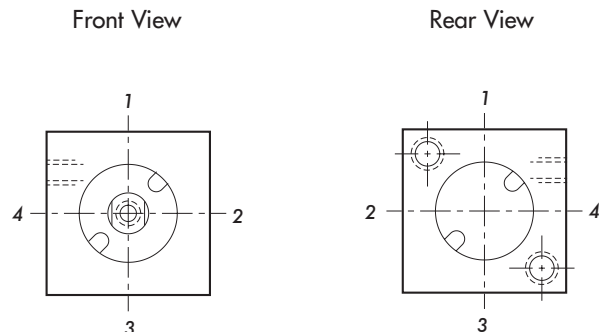

Orientation of porting and mounting change

**Reminder:** This option is **not** applicable to Magnetic Piston cylinders.

# Rod Tap Information

## Usable Female Rod Thread

On magnetic piston style cylinders, refer to 1/4" longer **stroke** when determining tap depth.

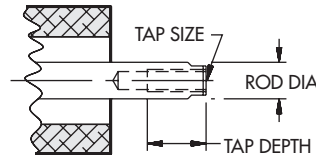

Bore	Rod Diameter	Rod Tap		Duty	Tap Depths (Stroke)								
		Standard	Optional Suffix: FT		1/8	1/4	3/8	1/2	5/8	3/4	7/8	1" and longer	
1/2	.25	#8-32	-	Standard	.25	.25	.38	.44	.44	.44	.44	.44	.44
				Intermediate	.25	.38	.44	.44	.44	.44	.44	.44	
				Heavy	.25	.38	.44	.44	.44	.44	.44	.44	
3/4	.31	#10-24	#10-32	Standard	.25	.38	.38	.44	.44	.44	.44	.44	
				Intermediate	.38	.44	.44	.44	.44	.44	.44	.44	
				Heavy	.44	.44	.44	.44	.44	.44	.44	.44	
1-1/8	.50	5/16-18	5/16-24	Standard	.31	.38	.44	.50	.63	.69	.81	.81	
				Intermediate	.44	.50	.63	.69	.81	.81	.81	.81	
				Heavy	.63	.69	.81	.81	.81	.81	.81	.81	
1-3/8	.63	3/8-16	3/8-24	Standard	.44	.44	.50	.50	.69	.81	.88	.94	
				Intermediate	.50	.50	.69	.81	.88	.94	.94	.94	
				Heavy	.69	.81	.88	.94	.94	.94	.94	.94	
1-5/8	.63	3/8-16	3/8-24	Standard	.44	.44	.50	.50	.69	.81	.88	.94	
				Intermediate	.50	.50	.69	.81	.88	.94	.94	.94	
				Heavy	.69	.81	.88	.94	.94	.94	.94	.94	
2	.63	3/8-16	3/8-24	Standard	.50	.50	.69	.69	.81	.88	.94	.94	
				Intermediate	.69	.69	.81	.88	.94	.94	.94	.94	
				Heavy	.81	.88	.94	.94	.94	.94	.94	.94	
2-1/2	.75	1/2-13	1/2-20	Standard	.50	.63	.63	.75	.88	1.00	1.00	1.25	
				Intermediate	.63	.75	.88	1.00	1.00	1.25	1.25	1.25	
				Heavy	.88	1.00	1.00	1.25	1.25	1.25	1.25	1.25	
3	.75	1/2-13	1/2-20	Standard	.50	.63	.63	.75	.88	1.00	1.00	1.25	
				Intermediate	.63	.75	.88	1.00	1.00	1.25	1.25	1.25	
				Heavy	.88	1.00	1.00	1.25	1.25	1.25	1.25	1.25	
4	.75	1/2-13	1/2-20	Standard	.63	.75	.75	.88	.88	.88	1.00	1.25	
				Intermediate	.75	.88	.88	.88	1.00	1.25	1.25	1.25	
				Heavy	.88	.88	1.00	1.25	1.25	1.25	1.25	1.25	
5	.75	1/2-13	1/2-20	Standard	.63	.75	.75	.88	.88	.88	1.00	1.25	
				Intermediate	.75	.88	.88	.88	1.00	1.25	1.25	1.25	
	1.00	5/8-18	-	Heavy	.88	.94	1.00	1.25	1.25	1.25	1.25	1.25	
6	1.00	5/8-18	-	Standard	.75	.81	.88	.94	1.00	1.00	1.25	1.25	
8	1.00	5/8-18	-	Standard	.75	.81	.88	.94	1.00	1.00	1.25	1.25	

For low cost male thread see the Accessories section, Male Stud on page 76.

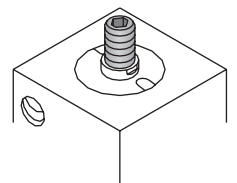

## Usable Wrench Flats

Bore	A	B Flat	C Dia
1/2	.06	.22	.25
3/4	.06	.25	.31
1-1/8	.13	.44	.50
1-3/8, 1-5/8, 2"	.13	.56	.63
2-1/2, 3, 4, 5"	.13	.69	.75
5FH, 6, 8"	.13	.94	1.00

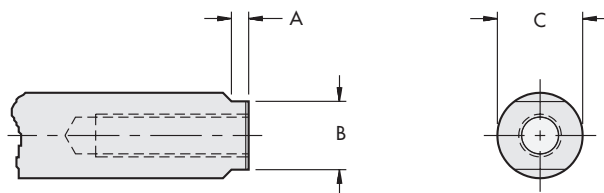



# Cylinder Weight

## Approximate Unit Weights (Ounces)

Ounces to Grams (Ounces x 28.349 = Grams)

Example: AS34x214

A	Magnetic Piston	.55	
S34	Square 3/4" bore	2.0	
x			
214	# of 1/8" increments	3.6	(.2x18)
		6.15	ounces

### Rectangular and Square body styles

	Duty	Non-Magnetic Piston					Magnetic Piston Adder				
		Standard		Intermediate	Heavy		Standard		Intermediate	Heavy	
		Single	Double	Single	Single	Double	Single	Double	Single	Single	Double
1/2	Zero stroke	.90	.95	1.10	1.20	1.20	.45	.50	.40	.40	.40
	per 1/8" stroke	.15	.20	.15	.15	.20					
3/4	Zero stroke	2.00	2.10	3.00	3.80	4.00	.55	.60	.70	.85	.90
	per 1/8" stroke	.20	.30	.20	.20	.30					
1-1/8	Zero stroke	3.10	3.30	4.40	5.70	6.10	.75	.80	1.20	1.55	1.60
	per 1/8" stroke	.30	.50	.30	.30	.50					
1-3/8	Zero stroke	5.50	6.10	7.40	9.50	10.10	.95	1.00	1.65	2.10	2.35
	per 1/8" stroke	.50	.60	.50	.50	.60					
1-5/8	Zero stroke	6.80	7.40	9.10	11.20	12.0	1.20	1.20	2.10	2.65	3.00
	per 1/8" stroke	.60	.70	.60	.60	.70					
2	Zero stroke	11.80	12.10	15.30	18.40	19.00	.95	1.65	1.85	3.05	3.50
	per 1/8" stroke	.90	1.00	1.00	.90	1.00					
2-1/2	Zero stroke	18.40	19.40	23.30	27.60	29.00	2.30	2.35	4.55	6.35	6.80
	per 1/8" stroke	1.20	1.50	1.20	1.20	1.50					
3	Zero stroke	30.40	31.10	36.70	42.30	43.60	3.20	3.25	6.10	8.80	9.00
	per 1/8" stroke	1.80	2.10	1.80	1.80	2.10					

### Round body styles

	Duty	Non-Magnetic Piston					Magnetic Piston Adder				
		Standard		Intermediate	Heavy		Standard		Intermediate	Heavy	
		Single	Double	Single	Single	Double	Single	Double	Single	Single	Double
1/2	Zero stroke	1.1	1.2	1.3	1.5	1.5	1.6	1.7	1.8	2	2
	per 1/8" stroke	.2	.2	.2	.2	.2	.2	.2	.2	.2	.2
3/4	Zero stroke	2.20	2.20	3.20	4.00	4.10	.11	.16	.25	.43	.44
	per 1/8" stroke	.30	.40	.30	.30	.40					
1-1/8	Zero stroke	3.70	4.00	5.10	6.40	6.80	.38	.40	.78	1.14	1.22
	per 1/8" stroke	.50	.60	.50	.50	.60					
1-3/8	Zero stroke	6.30	6.90	8.30	10.10	10.90	.59	.62	1.26	1.73	1.96
	per 1/8" stroke	.60	.70	.60	.60	.70					
1-5/8	Zero stroke	7.80	8.20	10.00	12.00	12.80	.89	.90	1.79	2.36	2.70
	per 1/8" stroke	.70	.80	.70	.70	.80					
2	Zero stroke	13.10	13.40	16.60	19.70	20.30	.80	1.51	1.72	2.91	3.35
	per 1/8" stroke	1.00	1.10	1.00	1.00	1.10					
2-1/2	Zero stroke	19.60	20.60	24.30	28.80	30.10	2.27	2.31	4.49	6.30	6.75
	per 1/8" stroke	1.10	1.40	1.10	1.10	1.40					
3	Zero stroke	30.50	31.20	36.80	42.40	43.70	3.37	3.41	6.24	8.93	9.15
	per 1/8" stroke	1.10	1.60	1.10	1.10	1.60					
4	Zero stroke	51.50	53.00	60.60	68.90	71.30	5.07	5.01	9.89	14.86	14.65
	per 1/8" stroke	1.60	1.90	1.60	1.60	1.90					
5	Zero stroke	79.30	80.90	88.10	105.70	109.20	8.09	8.19	15.89	23.01	22.93
	per 1/8" stroke	1.90	2.20	1.90	1.90	2.20					
6	Zero stroke	124.20	127.50	-	-	-	12.00	11.27	-	-	-
	per 1/8" stroke	2.40	2.90	-	-	-					
8	Zero stroke	229.10	233.00	-	-	-	19.28	18.27	-	-	-
	per 1/8" stroke	3.10	3.50	-	-	-					



## Approximate Unit Weights (Ounces)

Accessories													
Suffix	Description	Bore											
		1/2	3/4	1-1/8	1-3/8	1-5/8	2	2-1/2	3	4	5	6	8
<b>ADJ</b>	Adjustable Retract Stroke	.37	.61	1.53	1.97	2.31	5.09	5.96	10.10	CF	CF	CF	CF
<b>CBSS</b>	Clevis Bracket	.26	.79	1.37	2.17	2.17	2.17	4.18	4.18	4.18	4.18	39.84	39.84
<b>EB</b>	End Bracket (flange)	.19	.36	.44	.94	1.31	2.01	2.35	4.66	-	-	-	-
<b>FF</b>	Front Flange ("S") style only)	.28	.84	1.11	1.78	1.74	4.85	5.31	9.10	-	-	-	-
<b>FF</b>	Front Flange ("R") style only)	.28	1.28	2.03	1.77	1.89	4.72	5.59	9.10	16.26	61.90	157.0	157.0
<b>LP</b>	Long Pivot Mount	-	2.63	2.79	3.26	5.58	7.21	13.27	14.31	42.57	-	-	-
<b>MS</b>	Male Stud	.04	.06	.24	.43	.43	.43	.96	.96	1.12	1.12	1.90	1.90
<b>NM</b>	Nose Mount	.25	3.43	2.09	3.05	3.78	5.67	9.76	12.33	24.00	33.83	-	-
<b>PS</b>	Pivot Shaft	-	.94	1.10	1.22	1.31	3.28	6.43	7.70	27.00	33.14	39.75	46.51
<b>RE</b>	Rod Eye	.13	.51	.54	1.01	1.01	1.01	3.82	3.82	3.82	3.82	21.80	21.80
<b>RF</b>	Rear Flange ("S") style only)	.28	.84	1.11	1.78	1.74	4.85	5.31	9.10	-	-	-	-
<b>RF</b>	Rear Flange ("R") style only)	.28	1.28	2.03	1.77	1.89	4.72	5.59	9.10	16.26	61.90	157.00	157.00
<b>SB</b>	Side Bracket (flange)	.19	.43	.49	.99	1.26	1.89	2.15	3.94	-	-	-	-
<b>SP</b>	Short Pivot Mount	-	1.96	2.12	2.25	2.34	7.59	10.74	14.17	37.70	55.83	62.44	69.20
<b>SRC</b>	Short Rear Clevis	.28	.86	1.52	2.97	3.35	5.54	10.91	12.88	-	-	-	-
<b>SRCE</b>	Short Rear Clevis with Eye Mount	.50	1.37	2.19	4.36	4.75	7.28	12.69	19.36	-	-	-	-

CF = Consult Factory

Air-Oil Systems, Inc. www.airoil.com

## Disassembly

### 1/2" Bore (Snap Cap)

1. Place cylinder under small arbor press, rear end cap up. Apply 15 pounds of force.
2. Push the end cap down into the cylinder frame, retainer seal will remain in groove.
3. With an o-ring tool remove the retainer seal.
4. Push the piston rod assembly up to remove the rear face end cap.
5. Do not remove the piston rod assembly.
6. Turn cylinder over.
7. Repeat steps 1-3, push rod end cap out with piston rod assembly and remove both.

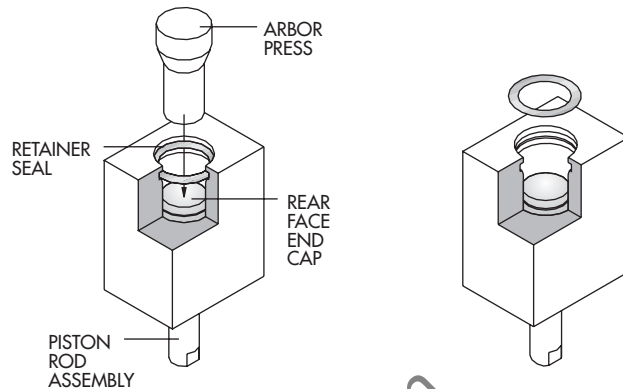

### 3/4" - 8" Bore

1. Place cylinder in vise, rear end cap up
2. Place spanner wrench pins in notches of the end cap
3. Turn clockwise. The retaining wire will back out of the cylinder.
4. Stop turning when wire becomes loose.
5. Push the end cap down into the frame.
6. Remove the wire by pulling the hooked end *from the cylinder bore*.
7. Push the piston rod assembly up to remove the end cap.
8. Do not remove piston rod assembly.
9. Turn cylinder over.
10. Repeat steps 1-6, push front end cap out with piston rod assembly and remove both.

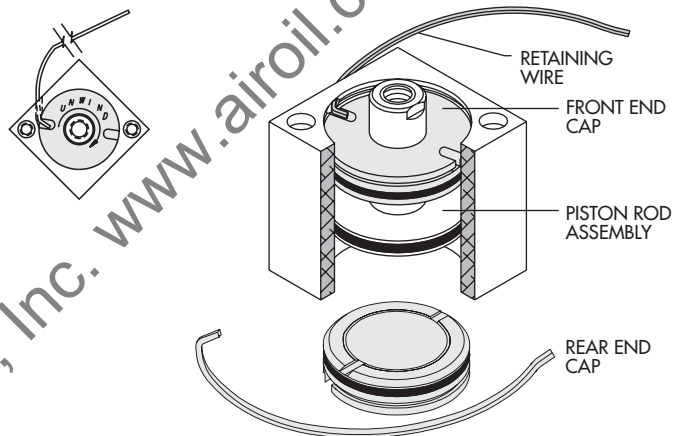

### General Repair Instructions

1. Remove any seal that becomes visible during repair with an o-ring tool.
2. Clean all grooves with a soft cloth.
3. Lightly lubricate seal grooves, reset seals and lubricate again.
4. Repeat above steps, in reverse, to reassemble.
5. Bubble test cylinder to assure air tight seal.

### Double Rod Instructions - 3/4" through 8"

1. Using snap ring pliers, remove first snap ring.
2. Remove piston from rod and remove snap ring from opposite side.
3. Remove inner piston seal with an o-ring tool and reset seals as detailed above.
4. Reset snap ring with flat side facing out from center.
5. Place piston over seal.
6. Reset opposite snap ring with flat side facing out from center.
7. Reassemble and bubble test.

# Repair Kits

## Repair Kits

Bore	Repair Kits						Tools		Lubrication
	Rod End	Standard	Viton®	Teflon®	Hydraulic	Viton® Hyd	Assembly Wrench	Flat Wrench	
1/2	Single	RK12	RKV12	-	-	-	-	FW1S	Lube One Lubricates approximately 30 medium size cylinders.
	Double	RKD12	RKDV12						
3/4	Single	RK34	RKV34	RKT34	RKH34	RKVH34	W1	FW2S	
	Double	RKD34	RKDV34	RKDT34	RKDH34	RKDVH34			
1-1/8	Single	RK118	RKV118	RKT118	RKH118	RKVH118	W2	FW3S	
	Double	RKD118	RKDV118	RKDT118	RKDH118	RKDVH118			
1-3/8	Single	RK138	RKV138	RKT138	RKH138	RKVH138	W3	FW3S	
	Double	RKD138	RKDV138	RKDT138	RKDH138	RKDVH138			
1-5/8	Single	RK158	RKV158	RKT158	RKH158	RKVH158	W3	FW3S	
	Double	RKD158	RKDV158	RKDT158	RKDH158	RKDVH158			
2	Single	RK2	RKV2	RKT2	RKH2	RKVH2	W3	FW3S	
	Double	RKD2	RKDV2	RKDT2	RKDH2	RKDVH2			
2-1/2	Single	RK212	RKV212	RKT212	RKH212	RKVH212	W3	FW3S	
	Double	RKD212	RKDV212	RKDT212	RKDH212	RKDVH212			
3	Single	RK3	RKV3	RKT3	RKH3	RKVH3	W3	FW3S	
	Double	RKD3	RKDV3	RKDT3	RKDH3	RKDVH3			
4	Single	RK4	RKV4	RKT4	RKH4	RKVH4	W3	FW3S	
	Double	RKD4	RKDV4	RKDT4	RKDH4	RKDVH4			
5	Single	RK5	RKV5	-	-	-	W3	FW3S	
	Double	RKD5	RKDV5						
FH5	Single	RKFH5	RKFHV5	-	-	-	W3	FW3S	
	Double	RKFHD5	RKFHDV5						
6	Single	RK6	RKV6	-	-	-	W3	FW3S	
	Double	RKD6	RKDV6						
8	Single	RK8	RKV8	-	-	-	W3	FW3S	
	Double	RKD8	RKDV8						

Part No. FWS  
Includes one each  
FW1S, FW2S, FW3S

Repair Kits apply to Non-Magnetic and Magnetic piston cylinders, any duty.

All Repair Kits Include:

- Endcap Seals
- Shaft Seals
- Piston Seals
- Retaining Wire\*
- Lubrication (1 to 4 milliliters)
- Snap Rings - *RKD kits only*
- Magnets

\*3/4" through 1-5/8" Bore Repair Kits only  
2" Bore and larger -- must be ordered separately.

# Application Ideas

With only minor modification to Compact® cylinder bodies and rod ends, these non-standard cylinder can be built and delivered quickly and cost effectively in any quantity.

## Back-to-Back 3 or 4 positions

Equal stroke increments provide 3 positions.

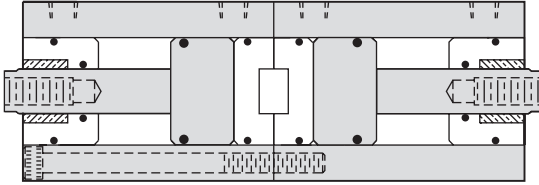

Unequal stroke increments provide 3 or 4 positions, depending on sequence of operation.

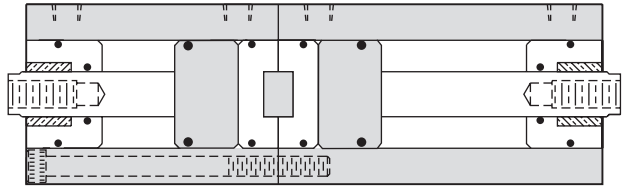

- Back-to-back assemblies feature a pilot locator between the cylinder to assure positive alignment.
- Cylinder must have support when used in a non-vertical application.
- 4-way valve circuit required for each cylinder.

## Multi-Position 3 or more positions

Three or more stroke increments can be achieved with "in line" multi-position cylinders.

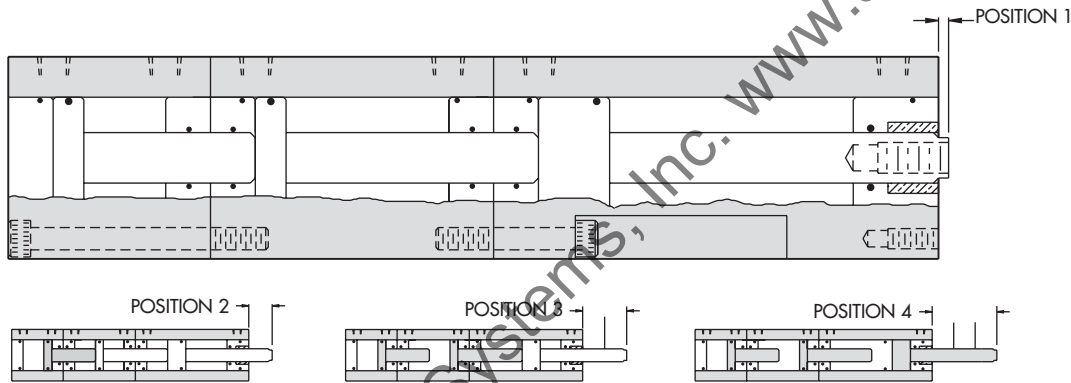

- Precise valve circuit design is critical.
- Front cylinder must include all previous cylinder increments. Example: Increments include 1" + 1" + 1". Front cylinder stroke 3", middle cylinder 2", back cylinder 1".

## Multi-Piston High Output

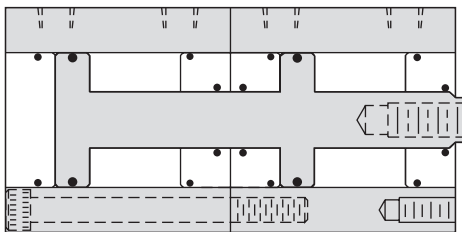

- Numerous pistons can be coupled to achieve extra output in limited space applications.
- Individual cylinders with a common rod, as shown in this diagram, can provide multiple output for push and pull.

For design assistance and quotes contact your local distributor or our Technical Sales Department at (864) 647-9521.

## Modifications to fit Customer Requirements

Compact Automation Product's Technical Sales team understands the ever-changing industry.

Each modified design is its own, requiring application - specific parts and know-how. We at Compact Automation Products pride ourselves in our ability to create or modify a cylinder to fit your application.

Do you have an unusual space situation, material requirement, or other specific need you think is hopeless?

If you think it can't be done, we think IT CAN.

For your convenience, see the Request for Quote form, on pages 101 and 102.

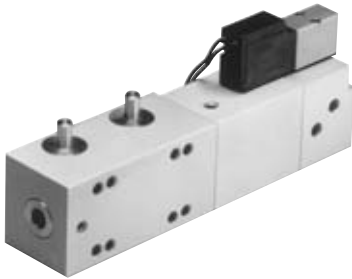

**Medical Device**  
Twin Pinion/Common Rack 90°  
Actuator

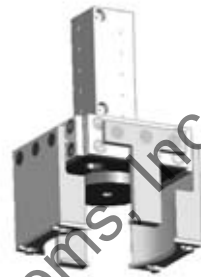

**Food Processing Machine**  
Multi-axis gripper with  
all Stainless Steel  
components



**Semi Conductor Industry**  
Heavily modified frame and  
oversized hollow rod



**PCB Machine Tool**  
Direct mounted control valve

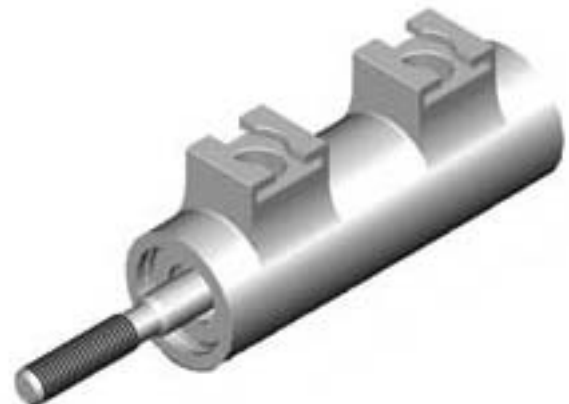

**Entertainment Industry Animation Cylinder**  
Custom stainless steel body for hydraulic service

# Request for Quote

## Modified Cylinder Proposal

Date Requested \_\_\_\_\_

Date Quoted \_\_\_\_\_

### From

Company Name \_\_\_\_\_

City \_\_\_\_\_ State \_\_\_\_\_

Contact \_\_\_\_\_

Phone \_\_\_\_\_ Fax \_\_\_\_\_

E-mail \_\_\_\_\_

### To

Compact Automation Products, Inc.

Contact (if known) \_\_\_\_\_

Current Compact Distributor \_\_\_\_\_

Contact \_\_\_\_\_

*– All modified and special purpose air cylinders are manufactured from our standard product lines –  
To ensure a quick and accurate quote, please include all requirements.*

### Round or Square Style Cylinder

Basic Cylinder Part Number Required: \_\_\_\_\_

### Prototype:

Yes  No

### Quantity:

1 - 9 pcs.

10 - 24 pcs.

25 - 49 pcs.

50 - 99 pcs.

other:  \_\_\_\_\_

Air-Oil Systems, Inc. www.airoil.com

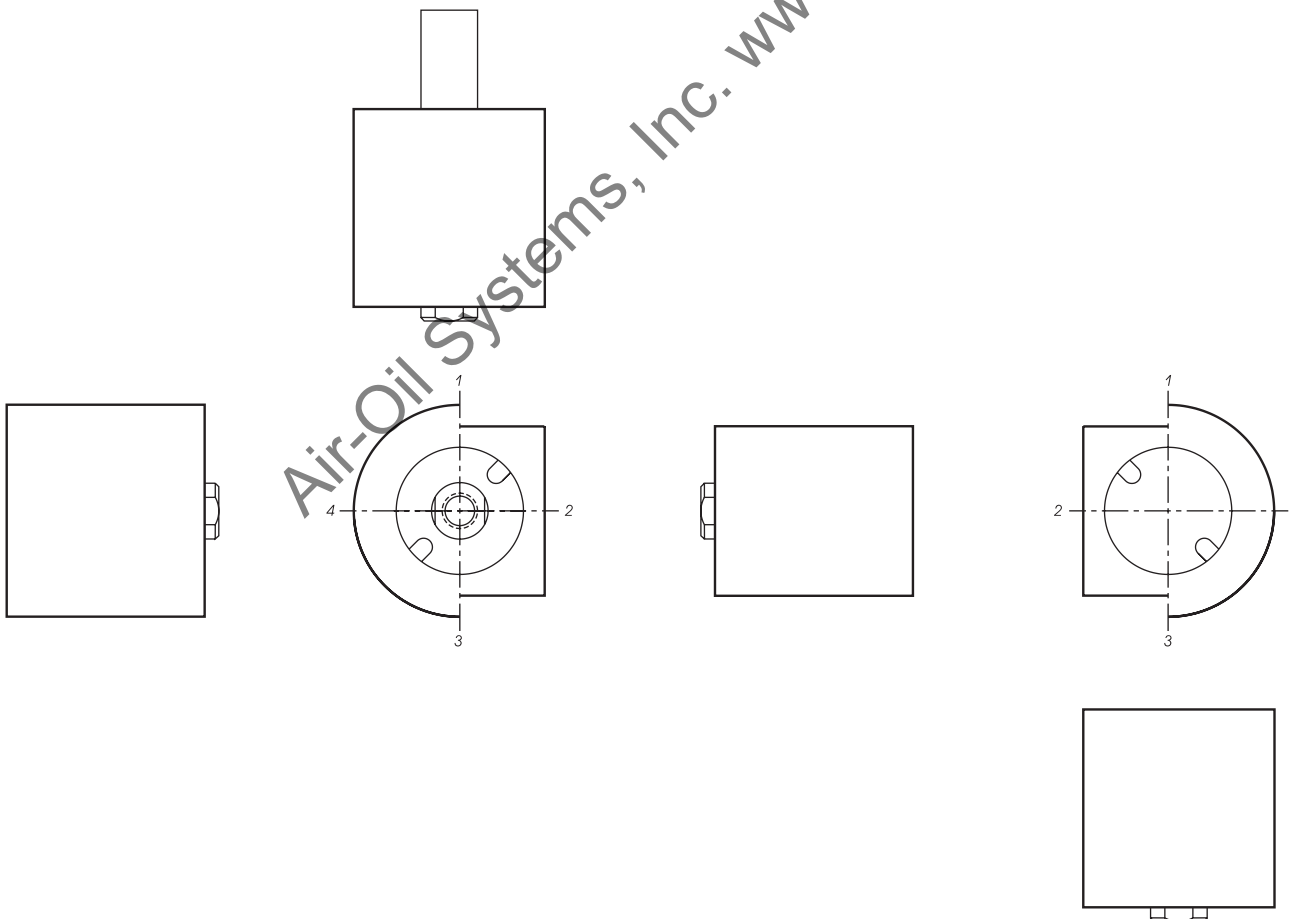

## Modified Hollow Rod Cylinder Proposal

Date Requested \_\_\_\_\_  
 Date Quoted \_\_\_\_\_

**From**  
 Company Name \_\_\_\_\_  
 City \_\_\_\_\_ State \_\_\_\_\_  
 Contact \_\_\_\_\_  
 Phone \_\_\_\_\_ Fax \_\_\_\_\_  
 E-mail \_\_\_\_\_

**To**  
 Compact Automation Products, Inc.  
 Contact (if known) \_\_\_\_\_  
 Current Compact Distributor \_\_\_\_\_  
 Contact \_\_\_\_\_

– All modified and special purpose air cylinders are manufactured from our standard product lines –  
**To ensure a quick and accurate quote, please include all requirements.**

**Round or Square Style Cylinder**

Basic Cylinder Part Number Required: \_\_\_\_\_

Hollow Rod Requirements:

- Base Rod Material  
 Stainless Steel  
 Other \_\_\_\_\_

- Prototype:**  Yes  No  
**Quantity:**  
 1 - 9 pcs.  
 10 - 24 pcs.  
 25 - 49 pcs.  
 50 - 99 pcs.  
 other:  \_\_\_\_\_

**Double Rod End**

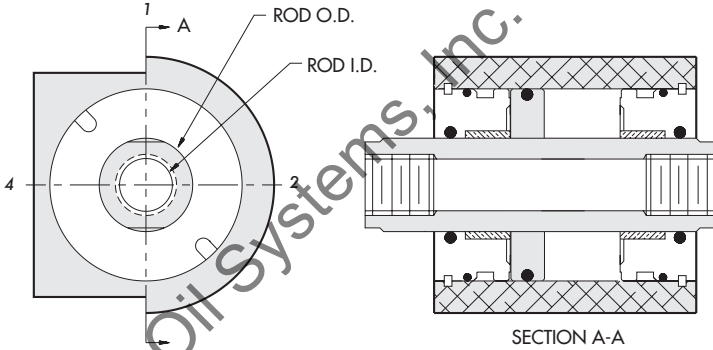

**Single Rod End Concept only**

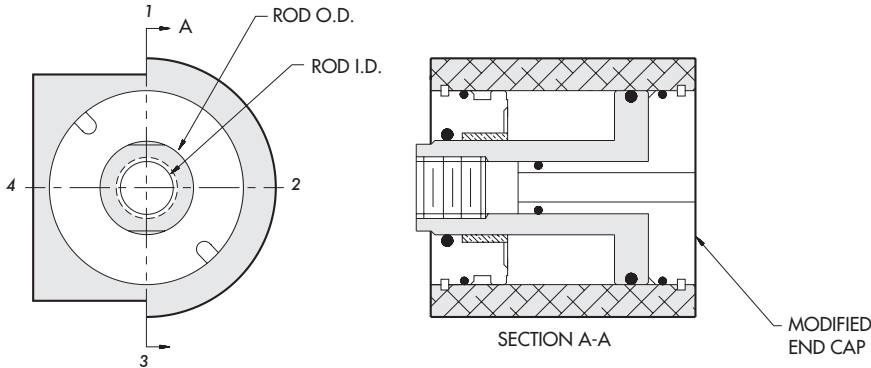

## Special Conditions and Limited Warranty

Determination of the suitability of any information or product for the application contemplated by any user or the manner of that use is the sole responsibility of the user.

Compact Automation Products, LLC reserves the right to improve or change designs without notice.

All orders are subject to acceptance by the factory sales department.

Compact Automation Products, LLC agrees to repair or replace to the original purchaser any standard parts or products for a period of 12 months from date of shipment which Compact Automation Products, LLC determines upon inspection to be defective in workmanship or material. Wear components including but not limited to seals and bearings are excluded from this warranty.

Under no circumstance may merchandise be returned without written authorization from the factory.

This warranty is void in the event the product has been tampered with, altered, or serviced by unauthorized personnel.

Compact Automation Products, LLC's, total responsibility for any claims, damages, losses or liabilities related to the product covered thereunder shall not exceed the purchase price of such product. In no event shall Compact Automation Products, LLC be liable for any special, indirect, incidental or consequential damages of any character, including but not limited to loss of use of productive facilities or equipment, lost profit, property damage, transportation, installation or removal or lost production whether suffered by purchaser or third party. Compact Automation Products, LLC disclaims all liability for any and all cost, claims demands, charges, expenses and other damages, either direct or indirect, incident to all property damage arising out of any cause of action based on strict liability. This warranty gives you specific legal rights and you may have other rights, which vary from state to state.

*Answer Engineering*  
**COMPACT**<sup>®</sup>  
**AUTOMATION PRODUCTS LLC**  
An **IMC** Company

Compact Automation Products, LLC  
105 Commerce Way  
Westminster, SC 29693  
USA  
Tel: 864.647.9521  
Fax: 864.647.9574  
[www.compactautomation.com](http://www.compactautomation.com)

Just imagine...  
How Compact's  
Answer Engineering can work for you!