

The Best Solution for Material Handling.

Vacuum suction cups can hold, lift or turn virtually any kind of material in the production process. The contact between a suction cup and the object to be handled is soft and light, and the technique is simple and safe.

Choosing the Right Suction Cup.

It is very important to choose the most appropriate type of vacuum suction cup, to obtain optimal results. ANVER has cups suitable for round, inclined, curved and irregular surfaces, and with our range of products you can find the best solution for every task.

The selection of a suction cup depends on particular conditions such as surface quality and structural stability of the work piece to be lifted and the desired material, shape, etc. of the suction cup. However, a simplified formula can be used to generate a theoretical estimate based on a few known values.

The diameter of the suction cup can be determined using the following formula:

How to Calculate the Diameter of Suction Cup Needed

U.S. Units

$$D = 0.44 \times \sqrt{\frac{a/2.2 \times s}{v/29.5 \times c}}$$

D = Diameter - inches
a = Mass lbs.
c = Number of Cups
v = Vacuum - in. of Hg
s = Safety Factor (at least 2)

Metric Units

$$D = 11.2 \times \sqrt{\frac{m \times s}{b \times c}}$$

D = Diameter - mm
m = Mass - Kg
c = Number of Cups
b = Vacuum - bar
s = Safety Factor (at least 2)

Lifting Capacity:

The lifting capacity of a vacuum cup can be theoretically determined at sea level by using the following formula:

$$C = \frac{.393 \times D^2 \times V}{N}$$

C = Lifting Capacity (lbs.)
D = Cup Diameter (in.)
V = Vacuum Level (in. Hg)
N = Desired Safety Factor

Safety factor for horizontal lifting applications should be at least (2).
Vertical lifting applications should have a safety factor of at least (4).

NOTE: This formula will give theoretical lifting capacity only. Actual lifting capacity should always be verified by user.



NOTE: A safety factor of at least 2 for horizontal lifts should always be used to compensate for numerous variables surrounding lifting applications while a safety factor of at least 4 should be used for vertical or tilting applications. A pull-off test should be performed at our factory to determine the absolute suction cup for your particular application. Contact one of our application engineers for more information.

The Widest Range of Cups.

You can find many types of vacuum suction cups, with different dimensions and forms, on our web site. Our technical department is at your disposal to consult in choosing the most suitable solution for your particular needs.

Advantages of ANVER Vacuum Suction Cups:

- The widest selection
- Different materials for various kinds of use
- Various temperature resistance levels
- Perfect adherence even in the presence of edges and angles



Vacuum Cups and Suction Cups

Material Selection Guide

CODE: Poor ● Good ●● Very Good ●●● Excellent ●●●●

ANVER Material Blend Code	Common Material Name	Shore A Hardness* (Durometer) +/- 5	Temperature Range ** °F (°C)	Abrasion Wear Resistance	Oil, Grease Resistance	UV Weather Aging Resistance	Typical Color (Depends on Cup Style)
For most General Purpose Industrial Applications							
NBR	Nitrile (Buna-N)	40 - 60	-40° to +230° F (-40° to +110° C)	●●●●●	●●●●●	●●●	Black, Blue
	NBR is an excellent all around material for general industry. High overall value due to its top performance in many categories.						
CR, NEO, NE, N50	Neoprene (Chloroprene)	40 - 60	-40° to +230° F (-40° to +110° C)	●●●●●	●●●●●	●●●	Blue, Red or Black
	N50 is an excellent hard wearing all around material for general industry with a nice rubber feel and memory.						
PUR	Polyurethane Anverflex™	30 - 65	-13° to +176° F (-25° to +80° C)	●●●●●	●●●●●	●●●	Blue, Green, White, all colors
	PUR is a tough, long wearing material. Suitable for many applications where heat is not a factor. Shiny gloss finish.						
For High Heat, Non-Marring Packaging and Food Use							
SIT	Silicone	40 - 60	-94° to +600° F (-70° to +316° C)	●●	●●●●●	●●●●●	Translucent Clear
	SIT is excellent for high heat or food packaging. Soft and pliable, meets FDA Title 21 and German spec. BGVV (BGA) Part XV for contaminant-free load handling. Contains no dyes that can leach out when handling baked goods, drugs, glassware, hot products from molds, etc.						
SI	Silicone	40 - 60	-94° to +392° F (-70° to +200° C)	●●	●●●●●	●●●●●	Solid White, Orange, Red
	SI is excellent for high heat applications such as mold part removal or where heat resistance is required for large cups/seals.						
S45, S60	Silicone	40 - 60	-58° to +401° F (-50° to +205° C)	●●	●●●●●	●●●●●	Orange, Red
	SI is excellent for high heat applications such as mold part removal or where heat resistance is required for large cups/seals.						
For the Printing, Paper and Wood Industries							
NR	Natural (Gum) Rubber	35 - 50	-40° to +176° F (-40° to +80° C)	●●●●●	●	●	Tan, Grey, Green, Orange or Black
	NR is widely used in the printing/paper/wood industries. Low cost, wears well and does not gum up with ink or cut paper dust. Not for general use.						
Specialty Elastomers							
SSD	Static Dissipative Silicone	50 - 60	-76° to +401° F (-60° to +205° C)	●●	●●	●●	Black, Grey (Carbon Filled)
	SSD is a specialized silicone with carbon that can handle heat and is static dissipative for high tech industries. It actually bleeds any static build-up out through a ground of the machine or other ground designed into the system.						
TPU	Thermal Polyurethane	75	-13° to +176° F (-25° to +80° C)	●●●●●	●●●●●	●●●●●	Translucent Brown (Darkens w/ Age)
	TPU is an extremely tough material. Long wearing but usually too expensive to justify its use. TPU's expense premium still far outweighs its increased performance over other recently improved materials.						
FPM	Viton® Fluorocarbon	60 - 65	-4° to +482° F (-20° to +250° C)	●	●●●●●	●●●●●	Usually Black, Blue
	FPM is specialized for high heat jobs. It has a stiff, somewhat dead feel for vacuum cups, is relatively expensive which limits its vacuum cup use. High Heat Silicone has replaced Viton for most applications.						
VYL	Vinyl***	30 - 70	+32° to +158° F (0° to +70° C)	●●●●●	●●	●●	Clear Base Blue / other colors
	VYL is soft, low cost, and readily available in many grades for general light-duty use. The injection molded vinyl ANVER uses in its industrial vacuum cups is high quality, but you loose a key advantage of low cost to other materials.						

Notes: * Various cup designs have different Durometers. Also note that a variance of +/- 5 in Shore Hardness or Durometer is the industry standard for all rubber products.
 ** The maximum temperature given is always for a momentary pick and place lift and not for a constant attach situation.
 *** Some materials such as Urethane or Vinyl have more general names which is like saying Rubber or Plastic. Within that name there are dozens of types and grades and it is difficult to make comparisons. For example, Vinyl is used for children's toys, wall hanging cups, soap dish mounts, but also high end products. It is often difficult to determine the quality you are receiving. We have found that only injection molded, pressurized and vulcanized vinyl is suitable for industrial-duty vacuum cups.



ANVER® Proprietary Designed Elastomer Materials for Vacuum Cups and Suction Cups

Our success as a leader and innovator in Vacuum Technology is due to the many important advances that we have made and continue to make in the selection of the elastomers used in our Vacuum Cups.

What is an Elastomer Vacuum Cup?

An elastomer is any type of polymer that has rubber-like properties of which there are dozens of material names. An elastomeric compound, consisting of a blend of a base polymer and other ingredients, is a material that has been designed to meet specific functional requirements.

A Vacuum Cup is only as good as its specific recipe or mixture of elastomeric compounds. The more expensive materials, available from the chemical product market leaders, usually result in the highest quality product consistency, which is why we stick with only ingredients from these suppliers. Each compound listed below is a specific blend of approx. a dozen line items, not a single ingredient as many people have come to believe. The following ingredients make up a typical Vacuum Cup formulation:

- Polymers** the basic gum-like component of a compound, provide certain chemical and mechanical properties in the final product.
- Fillers** reinforcing agents that enhance chemical and mechanical properties; adding carbon for example
- Vulcanization agents** to cross-link the polymers.
- Accelerators** to modify the rate of vulcanization.
- Activators** to initiate the vulcanization.
- Plasticizers** to soften or improve processing.
- Processing aids** to ease handling during mixing, extrusion, calendaring, or molding; and various mold release agents, sprays etc.
- Age-resistors** to reduce or retard aging.
Keep in mind that all rubber products have a defined working shelf life.
- Miscellaneous ingredients** such as blowing agents, pigments, retarders and odorants, all have specific purposes but are not necessarily required.

Consistent Quality Control

At ANVER, we take measures to control quality throughout every phase of the development process. By specifying the highest quality ingredients, auditing incoming raw materials, establishing good relationships with our suppliers, and insisting on quality and uniformity in the goods we purchase, we can ensure the consistency of our elastomeric Vacuum Cups, from initial development to final production. You will find that all of our vacuum cups offer high quality and top value in every market segment.

We mold with many other specialty materials, including Ethylene Propylene Diene Methylene (EPDM) and Electro Static Limiting ESD, (this is a plastic blend material which acts to limit the build-up of static charge by virtue of a more slippery surface, which reduces surface friction). Contact the factory for details.
Viton® is a registered trademark of DuPont Dow Elastomers.

ANVER Vacuum Lifters are designed in a modular fashion. Standard components are selected to match your application (Given the vast selection and inventory that we offer, this means a lifter to match almost any application can be quickly built). ANVER designs its lifters so that each pad bears an equal load weight.

In theory most steel and aluminum sheets can be handled with up to 5 inches of deflection at the outer edge without permanently bending the plate. ANVER, however, recommends a 2-inch deflection factor be used when determining the number of pads and required beam length. Based on our 30+ years experience in thousands of vacuum lifter applications, we have found that a 2-inch deflection offers an extra measure of lifting safety by reducing the curvature under the pads while at the same time making it easier to position the lifter on the load. In practice, it is difficult for operators to center a lifter using a 5-inch deflection design on a load.

In no case should the overhang indicated for a 5 inch deflection be exceeded.

The following procedure is recommended for vacuum lifter selection:

Selecting the Proper Beam and Crossarm Length and Lifting Pad Configuration

1) Identify the size of material to be lifted. Determine the minimum and maximum dimensions and maximum weight of the load. The minimum and maximum thickness are also critical.

2) Determine the allowable amount of load overhang. Overhang (L) and spacing between pads (2L) are based on the minimum thickness of material. Click here for acceptable Steel Plate Overhang or Aluminum Plate Overhang or Glass Plate Overhang . The thinnest material to be lifted should always be used to determine the allowable overhang.

3) Determine the number of pads Lengthwise. Referring to the appropriate table, determine the minimum number of pads required for the maximum load length, rounding up to the next highest number. For example, if the maximum length is 120 inches and the recommended spacing between pads is 60 inches, use a lifter with a minimum of two cups ($120/60=2$). Determine the minimum number of lifting pads required for the maximum load length by dividing the maximum load length by 2L and rounding to the next highest number.

4) Determine the number of pad rows. Determine the minimum number of lifting pads required for the maximum load width by dividing the maximum load width by the 2L number from the table and rounding up to the next highest number. For example, a load width of 72 inches with a recommended spacing between pads of 60 inches ($72/60=1.2$: rounded up to 2) requires a minimum of two pads along the width of the load.

5) Determine the beam length. The beam length is calculated by subtracting 2L from the maximum load length, then adding 6 inches to it. For example, with a maximum load length of 120 inches with a 2L of 60 inches, the minimum beam length would be 66 inches ($120-60+6$). If this is not a standard length, select the next longest standard beam length.

6) Determine the Required Length of Crossarms. Subtract 2L from the maximum load width and add 6 inches. If this is not a standard length, select the next longest standard crossarm length.

7) Selecting Vacuum Lifting Pad Size and Style.

Consider the following points when selecting the proper vacuum pads:

- The maximum weight to be lifted;
- The number of pads (calculated as explained above);
- The lifting surface and porosity of the load.

8) Follow these guidelines for selecting vacuum pads:

- Use the fewest number of pads necessary;
- Use pads with the largest possible diameter;
- The load width should never exceed five times the lifting pad width or diameter when handling a load with a single row of pads;
- Pad capacities must be derated by 50% when used for vertical handling or upending applications;
- Neoprene sealing rings are recommended for general use (load temperatures of up to 200 degrees F)
- Silicone sealing rings are recommended for applications where load surface marring is a concern or temperatures may exceed 200 degrees C (up to 500 degrees F).

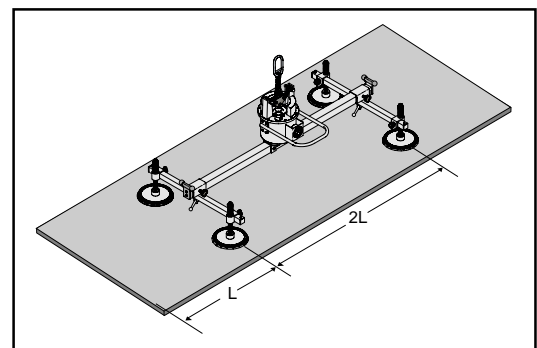
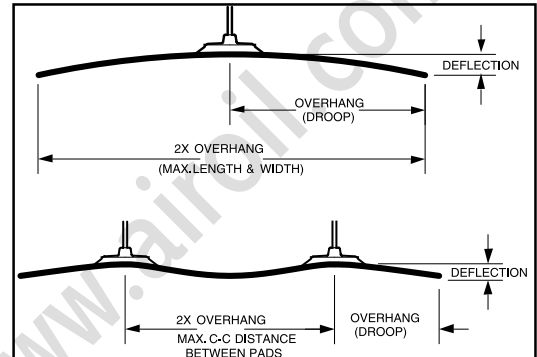

Selecting the Right Lifter

for Metal Sheet and Plate



Notes Regarding Deflection (Bending):

- 1) Brittle materials such as glass should be held nearly flat.
- 2) For other materials such as wood, particleboard, etc., deflection can be estimated by direct measure.

NOTE: Although multiple rows may not be required when using the above guidelines, they should be considered if load tipping is a concern.

While choosing the number of crossarm members on a vacuum lifter designed for up-ending (tilting), an even number of crossarms must be specified to prevent interference with the up-ending yoke.

Our applications engineers are always available to assist you in selecting the right vacuum lifter. Call or e-mail us for assistance.

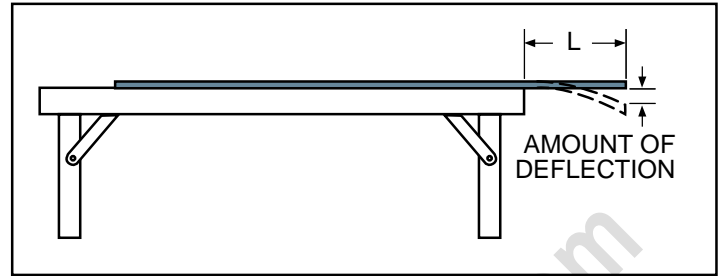

Air-Oil Systems, Inc. www.airoil.com



Air Consumptionis the rate at which compressed air is used within the system.

Air Vacuum Generatoris a vacuum system that operates on compressed air by applying venturi principles.

Blow-offis a blast of air that travels through the system against the vacuum. It is used to aid the release of items from the vacuum cups.

Economizer Versionis a system that regulates the vacuum level in the manifold and automatically controls the flow of compressed air into the generator. Program the vacuum level requirements into the unit, and it maintains them using check valves and electric or pneumatic switches to draw energy only when necessary.

Efficiencyrefers to the level of vacuum generated in the system. ANVER offers efficiencies of 75% vacuum and 90% vacuum or 22 in. Hg and 27 in. Hg, respectively.

Generatoris a vacuum system that operates on compressed air by applying venturi principles.

Flow Capacityrefers to the volume of air evacuated from the system. Generally this is stated as a rate, such as standard cubic feet per minute (SCFM). Multiply the manifold volume by the required number of cycles per minute.

Hysteresisis a lag in response time exhibited by a body in reacting to changes in forces acting upon it.

Manifoldis the collective volume of a vacuum system, including the cups, hose, fittings, and controls. It is the amount of air that will need to be evacuated to create a vacuum.

Nozzledetermines the dimensions and flow rates for the vacuum generator. ANVER offers five sizes to satisfy most applications.

PLC Device.....refers to a Programmable Logic Control Device, such as a computer or other digital controller.

Reservoiris a chamber used to store compressed air for blow-off.

SCFM.....Standard Cubic Feet per Minute.

Vacuum Level.....is the degree of vacuum generated. It may be expressed in percentage of vacuum, inches of mercury or any other vacuum or pressure unit.

Venturiis a vacuum generator that operates on compressed air by applying venturi principles.

Venturi Principleis based on the research of Giovanni Venturi, an Italian physicist who investigated the effect on fluids of conical expansions and contractions. For our purposes, forcing air through a small nozzle and its subsequent expansion creates a vacuum.



Unit Conversions

Dimensions

Beginning with:	Multiply by:	To obtain:
inches	25.4	mm
mm	0.03937	inches
ft ³	0.02832	m ³
ft ³	28.32	liters
in ³	5.79×10^{-4}	ft ³
cm ³	3.53×10^{-5}	ft ³
mm ³	3.53×10^{-8}	ft ³
m ³	35.31	ft ³
liters	0.03531	ft ³

Flow Rates

Beginning with:	Multiply by:	To obtain:
SCFM	28.32	liters/min.
liters/min	0.03531	SCFM
gal/min	0.00933	SCFM

Vacuum/Pressure

Beginning with:	Multiply by:	To obtain:
% Vacuum	0.3	inches Hg
inches Hg	3.333	% Vacuum
inches Hg	25.4	mm Hg
inches Hg	2.54	cm Hg
inches Hg	0.4898	psi
inches Hg	33.86	mBar
mm Hg	0.03937	inches Hg
cm Hg	0.3937	inches Hg
psi	2.0416	inches Hg
mBar	0.02953	inches Hg

Conversion factors may be rounded.
Vacuum always implies negative pressure.



Vacuum Cups and Suction Cups

Effect of Atmospheric Pressure on Vacuum Level



The basic formula is:

$$\text{Current atmospheric Pressure} \times \frac{\text{Max rated level of a vacuum pump}}{30" \text{ Hg (absolute vacuum)}}$$

It is important to consider the relationship between atmospheric pressure and altitude as it affects vacuum pump performance. Because free air is less dense at higher altitudes (i.e. lower atmospheric pressures) operation at these higher altitudes has the effect of reducing the capacity and maximum vacuum levels attainable. Refer to the following table to correct for performance at various altitudes.

Altitude Above Sea Level (Feet)	Altitude Above Sea Level (Meters)	Atmospheric Pressure (psi)	Maximum Vacuum Level Attainable (inches Hg)	Vacuum Level Loss at Altitude	Maximum Vacuum Level Possible at this Altitude
0'	0 M	14.70 psi	29.921" Hg	-	-
1000'	305 M	14.16 psi	28.9" Hg	3.4%	96.6%
2000'	610 M	13.66 psi	27.8" Hg	7.1%	92.9%
3000'	914 M	13.16 psi	26.8" Hg	10.4%	89.6%
4000'	1219 M	12.68 psi	25.8" Hg	13.8%	86.2%
5000'	1524 M	12.22 psi	24.9" Hg	16.8%	83.2%
6000'	1829 M	11.77 psi	24.0" Hg	19.8%	80.2%
7000'	2134 M	11.33 psi	23.1" Hg	22.8%	77.2%
8000'	2438 M	10.91 psi	22.2" Hg	25.9%	74.1%
9000'	2743 M	10.50 psi	21.4" Hg	28.6%	71.4%
10,000'	3048 M	10.10 psi	20.6" Hg	31.3%	68.7%
11,000'	3353 M	9.71 psi	19.8" Hg	33.9%	66.1%
12,000'	3658 M	9.34 psi	19.0" Hg	36.5%	63.5%
13,000'	3962 M	8.97 psi	18.3" Hg	39.0%	61.0%
14,000'	4267 M	8.62 psi	17.5" Hg	41.4%	58.6%
15,000'	4752 M	8.28 psi	16.9" Hg	43.6%	56.4%

7030201 This spec sheet was adapted for print from our website. Additional information and photos are available at www.anver.com.

Vacuum Cups and Suction Cups



Material Selection Guide

Pg-psig	Pa-psia	In. Hg	-mbar	Torr	-mm Hg	% Vacuum
0.00	14.70	0	0.00	760.0	0.0	0.0
0.49	14.24	1	33.86	734.6	25.4	3.3
0.98	13.75	2	67.72	709.2	50.8	6.6
1.47	13.26	3	101.58	683.8	76.2	9.9
1.96	12.76	4	135.44	658.4	101.6	13.2
2.45	12.27	5	169.30	633.0	127.0	16.5
2.95	11.78	6	203.16	607.6	152.4	19.8
3.44	11.29	7	237.02	582.2	177.8	23.1
3.93	10.80	8	270.88	556.8	203.2	26.4
4.42	10.31	9	304.74	531.4	228.6	29.7
4.91	9.82	10	338.60	506.0	254.0	33.0
5.40	9.33	11	372.46	480.6	279.4	36.3
5.89	8.84	12	406.32	455.2	304.8	39.6
6.38	8.35	13	440.18	429.8	330.2	42.9
6.87	7.86	14	474.04	404.4	355.6	46.2
7.36	7.36	15	507.90	379.0	381.0	49.5
7.86	6.87	16	541.76	353.6	406.4	52.8
8.35	6.38	17	575.62	328.2	431.8	56.1
8.84	5.89	18	609.48	302.8	457.2	59.4
9.33	5.40	19	643.34	277.4	482.6	62.7
9.82	4.91	20	677.20	252.0	508.0	66.0
10.31	4.42	21	711.06	226.6	533.4	69.3
10.80	3.93	22	744.92	201.2	558.8	72.6
11.29	3.44	23	778.78	175.8	584.2	75.9
11.78	2.95	24	812.64	150.4	609.6	79.2
12.27	2.45	25	846.50	125.0	635.0	82.5
12.76	1.96	26	880.36	99.6	660.4	85.8
13.26	1.47	27	914.22	74.2	685.8	89.1
13.75	0.98	28	948.08	48.8	711.2	92.4
14.24	0.49	29	981.94	23.4	736.6	95.7
14.70	0.00	29.92	1013.00	0.0	760.0	100.0

This spec sheet was adapted for print from our website. Additional information and photos are available at www.anver.com. 7030201