

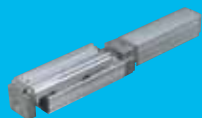

# Table Type/Arm Type Flat Type

RCP3  
RCA2  
RCA  
RCS2



RCP3/RCA2  
-TA3C



RCP3/RCA2  
-TA5C



RCP3/RCA2  
-TA7C



RCP3/RCA2  
-TA3R



RCP3/RCA2  
-TA5R



RCP3/RCA2  
-TA7R



RCA2-TC3N



RCA2-TW3N



RCA2-TF3N

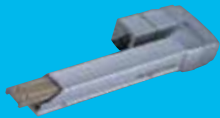

RCA/RCS2  
-A4R



RCA/RCS2  
-A6R

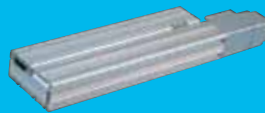

RCS2-F5D

<b>RCP3 series</b> Pulse Motor Type	Table Type	Inline Motor	36mm Width	RCP3-TA3C	<b>269</b>
			40mm Width	RCP3-TA4C	<b>271</b>
			55mm Width	RCP3-TA5C	<b>273</b>
			65mm Width	RCP3-TA6C	<b>275</b>
			75mm Width	RCP3-TA7C	<b>277</b>
	Side-Mounted Motor	36mm Width	RCP3-TA3R	<b>279</b>	
		40mm Width	RCP3-TA4R	<b>281</b>	
		55mm Width	RCP3-TA5R	<b>283</b>	
		65mm Width	RCP3-TA6R	<b>285</b>	
		75mm Width	RCP3-TA7R	<b>287</b>	

<b>RCA2 series</b> 24V Servo Motor Type	Table Type	Short-Length Compact Model	32mm Width	RCA2-TC3N	<b>289</b>
			36mm Width	RCA2-TC4N	<b>291</b>
	Short-Length Wide Model	50mm Width	RCA2-TW3N	<b>293</b>	
		58mm Width	RCA2-TW4N	<b>295</b>	
	Short-Length Flat Model	61mm Width	RCA2-TF3N	<b>297</b>	
		71mm Width	RCA2-TF4N	<b>299</b>	
		Inline Motor	40mm Width	RCA2-TA4C	<b>301</b>
	55mm Width		RCA2-TA5C	<b>303</b>	
	65mm Width		RCA2-TA6C	<b>305</b>	
	75mm Width		RCA2-TA7C	<b>307</b>	
	Side-Mounted Motor	40mm Width	RCA2-TA4R	<b>309</b>	
		55mm Width	RCA2-TA5R	<b>311</b>	
		65mm Width	RCA2-TA6R	<b>313</b>	
		75mm Width	RCA2-TA7R	<b>315</b>	

<b>RCA series</b> 24V Servo Motor Type	Arm Type	40mm Width	RCA-A4R	<b>317</b>
		52mm Width	RCA-A5R	<b>319</b>
		58mm Width	RCA-A6R	<b>321</b>

<b>RCS2 series</b> 200V Servo Motor Type	Arm Type	40mm Width	RCS2-A4R	<b>323</b>
		52mm Width	RCS2-A5R	<b>325</b>
		58mm Width	RCS2-A6R	<b>327</b>
	Flat Type	55mm Width	RCS2-F5D	<b>329</b>

- Slider Type
- Mini
- Standard
- Controllers Integrated
- Rod Type
- Mini
- Standard
- Controllers Integrated
- Table/Arm/Flat Type
- Mini
- Standard
- Gripper/Rotary Type
- Linear Servo Type
- Cleanroom Type
- Splash Proof
- Controllers
- PMEC/AMEC
- PSEP/ASEP
- ROBO NET
- ERC2
- PCON
- ACON
- SCON
- PSEL
- ASEL
- SSEL
- XSEL
- Pulse Motor
- Servo Motor (24V)
- Servo Motor (200V)
- Linear Servo Motor

# RCP3-TA3C

ROBO Cylinder Mini Table Type Motor Unit Coupled 36mm Width Pulse Motor Ball Screw

■ Configuration: **RCP3** — **TA3C** — **I** — **20P** —  —  —  —  —

Series — Type — Encoder — Motor — Lead — Stroke — Compatible Controllers — Cable Length — Option

I: Incremental \* The simple absolute encoder is also considered type "I".  
 20P: Pulse motor 20 □ size  
 6: 6mm  
 4: 4mm  
 2: 2mm  
 20: 20mm  
 100: 100mm (10mm pitch increments)  
 P1: PCON  
 RPCON  
 PSEL  
 P3: PMEC  
 PSEP  
 N: None  
 P: 1m  
 S: 3m  
 M: 5m  
 X □ □ : Custom  
 See Options below

\* See page Pre-35 for an explanation of the naming convention.

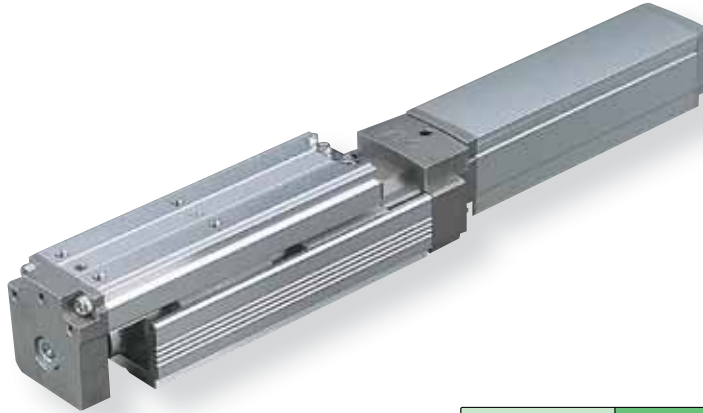

Technical References P. A-5



(1) The load capacity is based on operation at an acceleration of 0.3G (0.2G for the 2mm lead model, or when used vertically). 0.3G (0.2G for 2mm lead) is the upper limit of the acceleration.

■ Speed vs. Load Capacity  
 Due to the characteristics of the Pulse Motor, the RCP3 series' load capacity decreases at high speeds. In the table below, check if your desired speed and load capacity are supported.

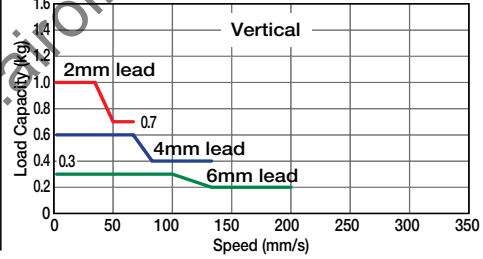
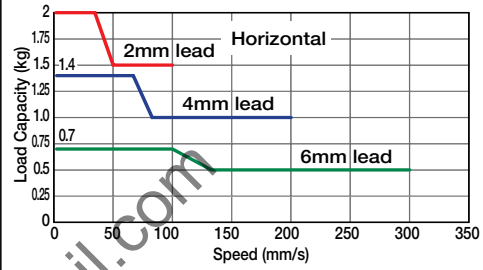

**Actuator Specifications**

■ Lead and Load Capacity (Note 1) Please note that the maximum load capacity decreases as the speed increases.

Model	Feed Screw	Lead (mm)	Mx. Load Capacity (Note 1) Horizontal (kg) Vertical (kg)	Maximum Push Force (N) (Note 2)	Positioning Repeatability (mm)	Stroke (mm)
RCP3-TA3C-I-20P-6-①-②-③-④	Ball Screw	6	~ 0.7 ~ 0.3	9	±0.02	20~100 (10mm increments)
RCP3-TA3C-I-20P-4-①-②-③-④		4	~ 1.4 ~ 0.6	14		
RCP3-TA3C-I-20P-2-①-②-③-④		2	~ 2 ~ 1	28		

Legend ① Stroke ② Compatible controller ③ Cable length ④ Options (Note 2) See page A-66 for pushing force graphs. \* The values enclosed in "< >" apply to vertical usage. (Unit: mm/s)

■ Stroke and Maximum Speed

Lead	Stroke	
	20 ~ 100 (mm)	200 ~ 300 (mm)
Ball Screw	6	300 <200>
	4	200 <133>
	2	100 <67>

① Stroke List

Stroke (mm)	Standard Price
20	-
30	-
40	-
50	-
60	-
70	-
80	-
90	-
100	-

③ Cable List

Type	Cable Symbol	Standard Price
Standard (Robot Cables)	P (1m)	-
	S (3m)	-
	M (5m)	-
Special Lengths	X06 (6m) ~ X10 (10m)	-
	X11 (11m) ~ X15 (15m)	-
	X16 (16m) ~ X20 (20m)	-

\* The RCP3 comes standard with a robot cable.  
 \* See page A-39 for cables for maintenance.

④ Option List

Name	Option Code	See Page	Standard Price
Brake	B	→ A-25	-
Reversed-home	NM	→ A-33	-

Actuator Specifications

Item	Description
Drive System	Ball screw ø6mm C10 grade
Lost Motion	0.1mm or less
Base	Material: Aluminum (white alumite treated)
Allowable Dynamic Moment (Note 3)	Ma: 3.2 N·m Mb: 4.6 N·m Mc: 5.1 N·m
Ambient Operating Temp./Humidity	0~40°C, 85% RH or less (non-condensing)

(Note 3) Based on a 5,000km service life.

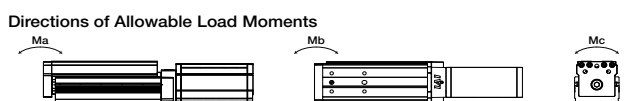

Dimensions

CAD drawings can be downloaded from IAI website. [www.intelligentactuator.com](http://www.intelligentactuator.com)

For Special Orders P. A-9

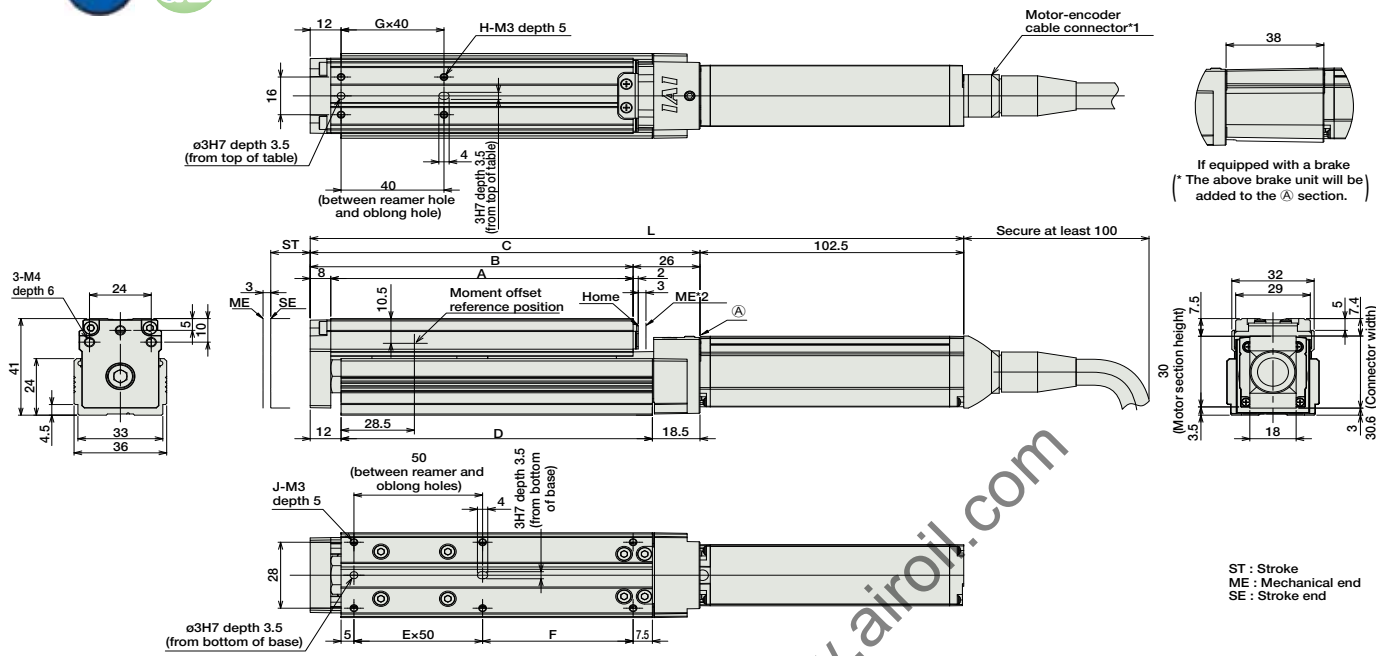

- \*1 The motor-encoder cable is connected directly to the motor cover of the actuator. See page A-39 for details on cables.
- \*2 When homing, the slider moves to the mechanical end; therefore, please watch for any interference with the surrounding objects.

■ Dimensions/Weight by Stroke \* Adding a brake will increase the actuator's weight by 0.1kg.

Stroke	20	30	40	50	60	70	80	90	100	
L	No Brake	224	234	244	254	264	274	284	294	304
	Brake-equipped	262	272	282	292	302	312	322	332	342
A	87.5	97.5	107.5	117.5	127.5	137.5	147.5	157.5	167.5	
B	95.5	105.5	115.5	125.5	135.5	145.5	155.5	165.5	175.5	
C	121.5	131.5	141.5	151.5	161.5	171.5	181.5	191.5	201.5	
D	91	101	111	121	131	141	151	161	171	
E	1	1	1	1	2	2	2	2	2	
F	28.5	38.5	48.5	58.5	68.5	78.5	88.5	98.5	108.5	
G	1	1	1	1	2	2	2	2	2	
H	4	4	4	4	6	6	6	6	6	
J	6	6	6	6	8	8	8	8	8	
Weight (kg)	0.5	0.5	0.5	0.6	0.6	0.6	0.6	0.7	0.7	

② Compatible Controllers

The RCP3 series actuators can operate with the controllers below. Select the controller according to your usage.

Name	External View	Model	Description	Max. Positioning Points	Input Voltage	Power Supply Capacity	Standard Price	See Page
Solenoid Valve Type		PMEC-C-20PI-NP-2-0	Easy-to-use controller, even for beginners	3 points	AC100V AC200V	See P481	-	→ P477
	Splash-Proof Solenoid Valve Type		PSEP-C-20PI-NP-2-0					
Positioner Type			PCON-C-20PI-NP-2-0	Positioning is possible for up to 512 points	512 points	DC24V	2A max.	-
	Safety-Compliant Positioner Type		PCON-CG-20PI-NP-2-0					
Pulse Train Input Type (Differential Line Driver)		PCON-PL-20PI-NP-2-0	Pulse train input type with differential line driver support	(-)	DC24V	2A max.	-	→ P525
Pulse Train Input Type (Open Collector)		PCON-PO-20PI-NP-2-0	Pulse train input type with open collector support					
Serial Communication Type		PCON-SE-20PI-N-0-0	Dedicated to serial communication	64 points				
Field Network Type		RPCON-20P	Dedicated to field network	768 points				→ P503
Program Control Type		PSEL-C-1-20PI-NP-2-0	Programmed operation is possible. Operation is possible on up to 2 axes	1500 points				→ P557

\* This is for the single-axis PSEL.  
\* ① is a placeholder for the power supply voltage (1: 100V, 2: 100~240V).

- Slider Type
- Mini
- Standard
- Controllers Integrated
- Rod Type
- Mini
- Standard
- Controllers Integrated
- Table/Arm/Flat Type
- Mini
- Standard
- Gripper/Rotary Type
- Linear Servo Type
- Cleanroom Type
- Splash Proof
- Controllers
- PMEC/AMEC
- PSEP/ASEP
- ROBO NET
- ERC2
- PCON
- ACON
- SCON
- PSEL
- ASEL
- SSEL
- XSEL
- Pulse Motor
- Servo Motor (24V)
- Servo Motor (200V)
- Linear Servo Motor

# RCP3-TA4C

ROBO Cylinder Mini Table Type Motor Unit Coupled 40mm Width Pulse Motor Ball Screw

■ Configuration: **RCP3** — **TA4C** — **I** — **28P** — [ ] — [ ] — [ ] — [ ] — [ ]

Series — Type — Encoder — Motor — Lead — Stroke — Compatible Controllers — Cable Length — Option

I: Incremental \* The simple absolute encoder is also considered type "I".  
 28P: Pulse motor 28 [ ] size  
 6: 6mm  
 4: 4mm  
 2: 2mm  
 20: 20mm  
 100: 100mm (10mm pitch increments)  
 P1: PCON  
 RPCON  
 PSEL  
 P3: PMEC  
 PSEP  
 N: None  
 P: 1m  
 S: 3m  
 M: 5m  
 X [ ] [ ]: Custom  
 See Options below

\* See page Pre-35 for an explanation of the naming convention.

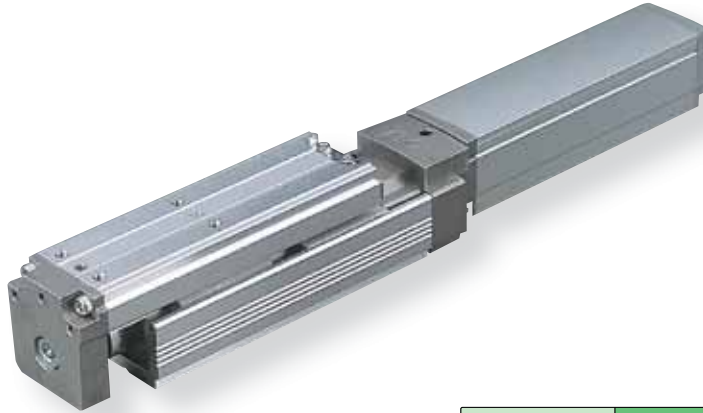

Technical References P. A-5



(1) The load capacity is based on operation at an acceleration of 0.3G (0.2G for the 2mm lead model, or when used vertically). 0.3G (0.2G for 2mm lead) is the upper limit of the acceleration.

■ Speed vs. Load Capacity  
 Due to the characteristics of the Pulse motor, the RCP3 series' load capacity decreases at high speeds. In the table below, check if your desired speed and load capacity are supported.

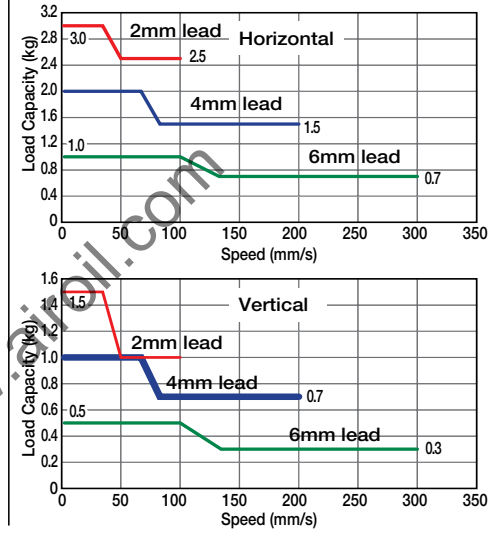

**Actuator Specifications**

■ Lead and Load Capacity (Note 1) Please note that the maximum load capacity decreases as the speed increases.

Model	Feed Screw	Lead (mm)	Mx. Load Capacity (Note 1) Horizontal (kg) Vertical (kg)	Maximum Push Force (N) (Note 2)	Positioning Repeatability (mm)	Stroke (mm)
RCP3-TA4C-I-28P-6-①-②-③-④	Ball Screw	6	~ 1 ~ 0.5	15	±0.02	20~100 (10mm increments)
RCP3-TA4C-I-28P-4-①-②-③-④		4	~ 2 ~ 1	22		
RCP3-TA4C-I-28P-2-①-②-③-④		2	~ 3 ~ 1.5	44		

Legend ① Stroke ② Compatible controller ③ Cable length ④ Options (Note 2) See page A-66 for pushing force graphs. (Unit: mm/s)

■ Stroke and Maximum Speed

Lead	Stroke (mm)	
	20 ~ 100 (mm)	20 ~ 100 (mm)
Ball Screw	6	300
	4	200
	2	100

① Stroke List

Stroke (mm)	Standard Price
20	-
30	-
40	-
50	-
60	-
70	-
80	-
90	-
100	-

③ Cable List

Type	Cable Symbol	Standard Price
Standard (Robot Cables)	P (1m)	-
	S (3m)	-
	M (5m)	-
Special Lengths	X06 (6m) ~ X10 (10m)	-
	X11 (11m) ~ X15 (15m)	-
	X16 (16m) ~ X20 (20m)	-
		-

\* The RCP3 comes standard with a robot cable.  
 \* See page A-39 for cables for maintenance.

④ Option List

Name	Option Code	See Page	Standard Price
Brake	B	→ A-25	-
Cable exit direction (Top)	CJT	→ A-25	-
Cable exit direction (Right)	CJR		
Cable exit direction (Left)	CJL		
Cable exit direction (Bottom)	CJB		
Reversed-home	NM	→ A-33	-

Actuator Specifications

Item	Description
Drive System	Ball screw ø6mm C10 grade
Lost Motion	0.1mm or less
Base	Material: Aluminum (white alumite treated)
Allowable Dynamic Moment (Note 3)	Ma: 4.2 N·m Mb: 6 N·m Mc: 8.2 N·m
Ambient Operating Temp./Humidity	0~40°C, 85% RH or less (non-condensing)

(Note 3) Based on a 5,000km service life.



Dimensions

CAD drawings can be downloaded from IAI website. [www.intelligentactuator.com](http://www.intelligentactuator.com)

For Special Orders P. A-9

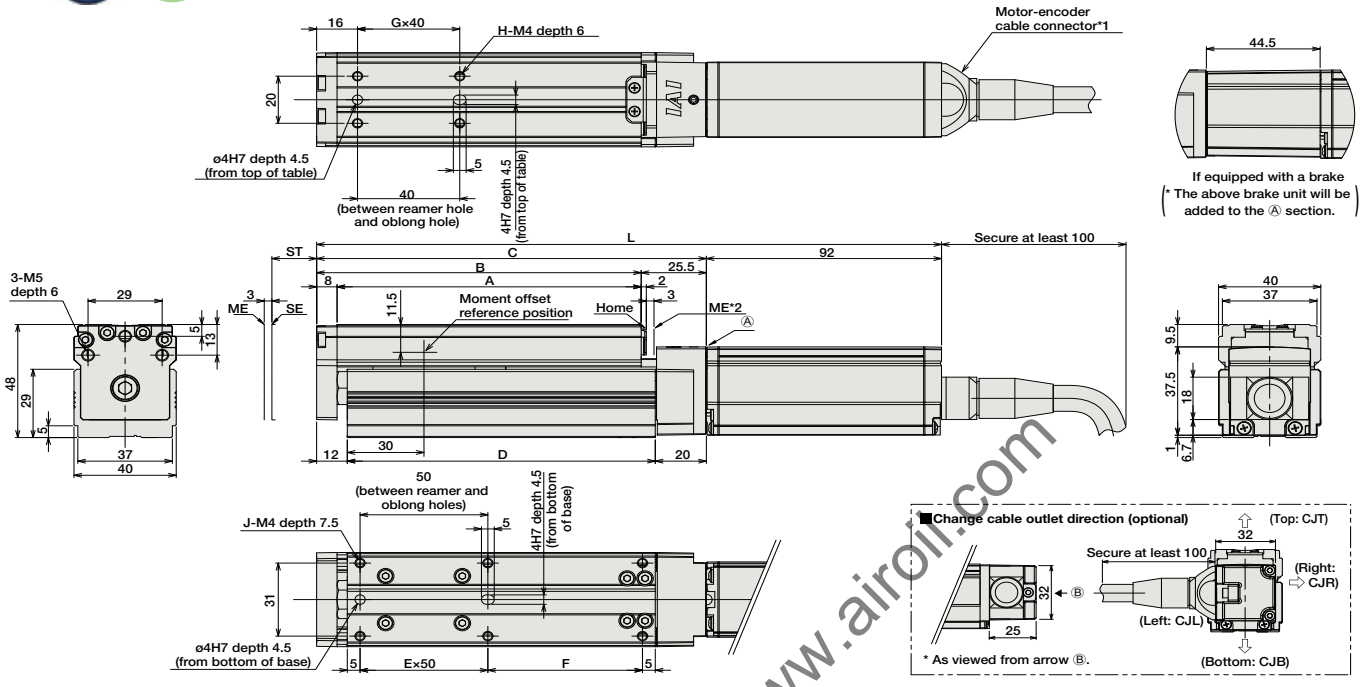

- \*1 The motor-encoder cable is connected directly to the motor cover of the actuator. See page A-39 for details on cables.
- \*2 When homing, the slider moves to the mechanical end; therefore, please watch for any interference with the surrounding objects.

ST : Stroke  
ME : Mechanical end  
SE : Stroke end

■ Dimensions/Weight by Stroke \* Adding a brake will increase the actuator's weight by 0.2kg.

Stroke	20	30	40	50	60	70	80	90	100	
L	No Brake	214.5	224.5	234.5	244.5	254.5	264.5	274.5	284.5	294.5
	Brake-equipped	259	269	279	289	299	309	319	329	339
A	89	99	109	119	129	139	149	159	169	
B	97	107	117	127	137	147	157	167	177	
C	122.5	132.5	142.5	152.5	162.5	172.5	182.5	192.5	202.5	
D	90.5	100.5	110.5	120.5	130.5	140.5	150.5	160.5	170.5	
E	1	1	1	1	2	2	2	2	2	
F	30.5	40.5	50.5	60.5	20.5	30.5	40.5	50.5	60.5	
G	1	1	1	1	2	2	2	2	2	
H	4	4	4	4	6	6	6	6	6	
J	6	6	6	6	8	8	8	8	8	
Weight (kg)	0.7	0.7	0.7	0.8	0.8	0.8	0.9	0.9	0.9	

② Compatible Controllers

The RCP3 series actuators can operate with the controllers below. Select the controller according to your usage.

Name	External View	Model	Description	Max. Positioning Points	Input Voltage	Power Supply Capacity	Standard Price	See Page
Solenoid Valve Type		PMEC-C-28PI-NP-2-①	Easy-to-use controller, even for beginners	3 points	AC100V AC200V	See P481	-	→ P477
		PSEP-C-28PI-NP-2-0	Operable with same signal as solenoid valve. Supports both single and double solenoid types. No homing necessary with simple absolute type.					→ P487
Splash-Proof Solenoid Valve Type		PSEP-CW-28PI-NP-2-0						
Positioner Type		PCON-C-28PI-NP-2-0	Positioning is possible for up to 512 points	512 points				
Safety-Compliant Positioner Type		PCON-CG-28PI-NP-2-0						
Pulse Train Input Type (Differential Line Driver)		PCON-PL-28PI-NP-2-0	Pulse train input type with differential line driver support	(-)	DC24V	2A max.		→ P525
Pulse Train Input Type (Open Collector)		PCON-PO-28PI-NP-2-0	Pulse train input type with open collector support					
Serial Communication Type		PCON-SE-28PI-N-0-0	Dedicated to serial communication	64 points				
Field Network Type		RPCON-28P	Dedicated to field network	768 points				→ P503
Program Control Type		PSEL-C-1-28PI-NP-2-0	Programmed operation is possible. Operation is possible on up to 2 axes	1500 points				→ P557

\* This is for the single-axis PSEL.  
\* ① is a placeholder for the power supply voltage (1: 100V, 2: 100~240V).

- Slider Type
- Mini
- Standard
- Controllers Integrated
- Rod Type
- Mini
- Standard
- Controllers Integrated
- Table/Arm /Flat Type
- Mini
- Standard
- Gripper/ Rotary Type
- Linear Servo Type
- Cleanroom Type
- Splash Proof
- Controllers
- PMEC /AMEC
- PSEP /ASEP
- ROBO NET
- ERC2
- PCON
- ACON
- SCON
- PSEL
- ASEL
- SSEL
- XSEL
- Pulse Motor
- Servo Motor (24V)
- Servo Motor (200V)
- Linear Servo Motor

# RCP3-TA5C

ROBO Cylinder Table Type Motor Unit Coupled 55mm Width Pulse Motor Ball Screw

■ Configuration: **RCP3** — **TA5C** — **I** — **35P** —  —  —  —  —

Series — Type — Encoder — Motor — Lead — Stroke — Compatible Controllers — Cable Length — Option

I: Incremental  
\* The simple absolute encoder is also considered type "I".

35P: Pulse motor 10: 10mm  
35  size 5: 5mm  
2.5: 2.5mm

10: 10mm  
25: 25mm  
100: 100mm (25mm pitch increments)

P1: PCON  
RPCON  
PSEL  
P3: PMEC  
PSEP

N : None  
P : 1m  
S : 3m  
M : 5m  
X  : Custom

See Options below

\* See page Pre-35 for an explanation of the naming convention.

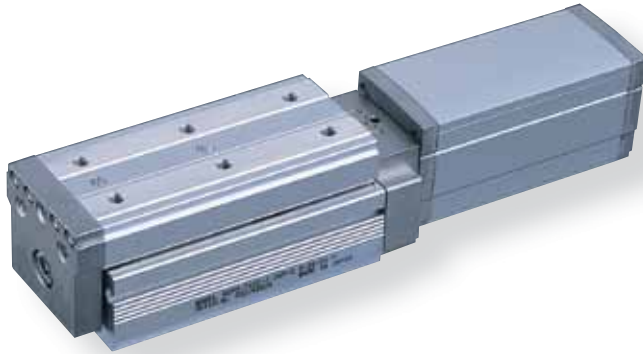

Technical References P. A-5

- POINT**  
Notes on Selection
- (1) Since the RCP3 series use a pulse motor, the load capacity decreases at high speeds. Check in the Speed vs. Load Capacity graph to see if your desired speed and load capacity are supported.
  - (2) Please note that the maximum speed is different when used horizontally versus vertically.
  - (3) The load capacity is based on operation at an acceleration of 0.3G (0.2G for the 2.5mm-lead model, or when used vertically). This is the upper limit of the acceleration.

### Speed vs. Load Capacity

Due to the characteristics of the Pulse motor, the RCP3 series' load capacity decreases at high speeds. In the table below, check if your desired speed and load capacity are supported.

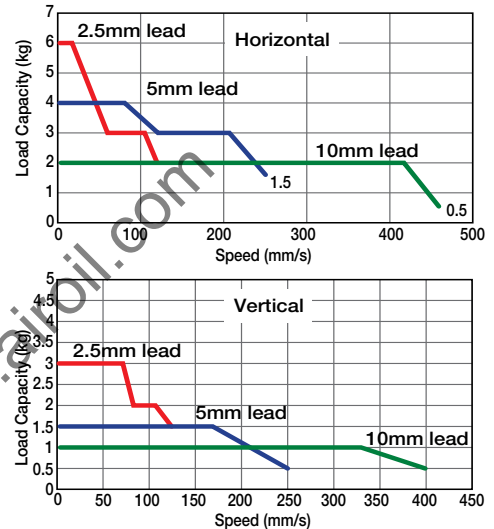

### Actuator Specifications

#### Lead and Load Capacity

(Note 1) Please note that the maximum load capacity decreases as the speed increases.

Model	Lead (mm)	Max. Load Capacity (Note 1)		Maximum Push Force (N) (Note 2)	Stroke (mm)
		Horizontal (kg)	Vertical (kg)		
RCP3-TA5C-I-35P-10-①-②-③-④	10	~ 2	~ 1	34	25~100 (25mm increments)
RCP3-TA5C-I-35P-5-①-②-③-④	5	~ 4	~ 1.5	68	
RCP3-TA5C-I-35P-2.5-①-②-③-④	2.5	~ 6	~ 3	136	

Legend ① Stroke ② Compatible controller ③ Cable length ④ Options

(Note 2) See page A-66 for pushing force graphs.

#### Stroke and Maximum Speed

Stroke / Lead	25 ~ 100 (25mm increments)	
	10	465 <400>
5	250	
2.5	125	

(Unit: mm/s)

#### ① Stroke List

Stroke (mm)	Standard Price
25	-
50	-
75	-
100	-

#### ③ Cable List

Type	Cable Symbol	Standard Price
Standard (Robot Cables)	P (1m)	-
	S (3m)	-
	M (5m)	-
Special Lengths	X06 (6m) ~ X10 (10m)	-
	X11 (11m) ~ X15 (15m)	-
	X16 (16m) ~ X20 (20m)	-
	-	-

\* The standard cable is the motor-encoder integrated robot cable.

\* See page A-39 for cables for maintenance.

#### ④ Option List

Name	Option Code	Standard Price	Standard Price
Brake	B	→ A-25	-
Cable exit direction (Top)	CJT	→ A-25	-
Cable exit direction (Right)	CJR	→ A-25	-
Cable exit direction (Left)	CJL	→ A-25	-
Cable exit direction (Bottom)	CJB	→ A-25	-
Reversed-home	NM	→ A-33	-

#### Actuator Specifications

Item	Description
Drive System	Ball screw ø8mm C10 grade
Positioning Repeatability	±0.02mm
Lost Motion	0.1mm or less
Base	Material: Aluminum (special alumite treated)
Allowable Static Moment	Ma: 25.5 N·m Mb: 36.5 N·m Mc: 56.1 N·m
Allowable Dynamic Moment (*)	Ma: 6.57 N·m Mb: 9.32 N·m Mc: 14.32 N·m
Overhang Load Length	Within the load moment range
Ambient Operating Temp./Humidity	0~40°C, 85% RH or less (non-condensing)

(\*) Based on a 5,000km service life.

#### Directions of Allowable Load Moments



Dimensions

CAD drawings can be downloaded from IAI website. [www.intelligentactuator.com](http://www.intelligentactuator.com)

For Special Orders P. A-9

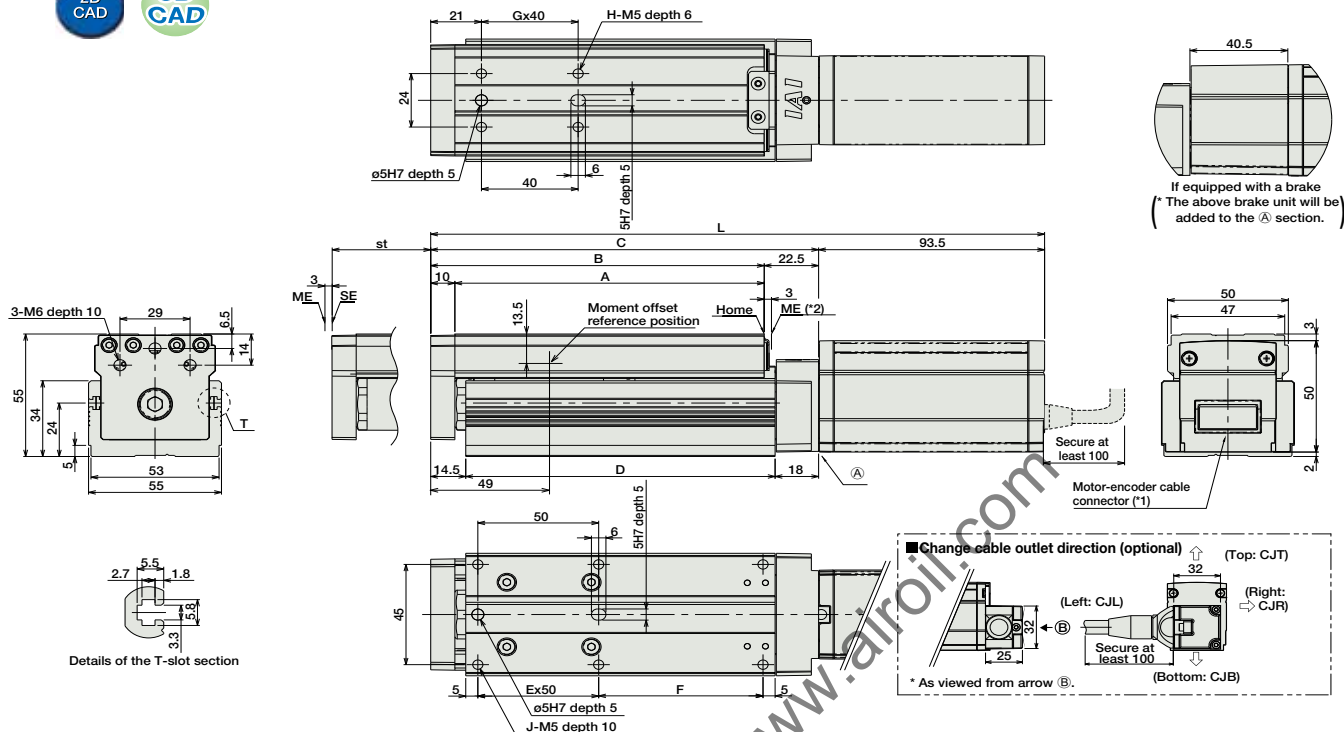

(\*1) The motor-encoder cable (integrated) is connected. (See page A-39 for details on cables.)  
 (\*2) After homing, the slider moves to the ME; therefore, please watch for any interference with the surrounding objects.  
 ME: Mechanical end  
 SE: Stroke end

■ Dimensions/Weight by Stroke \* Adding a brake will increase the actuator's weight by 0.3kg.

Stroke	25				50				75				100			
	No Brake		Brake-Equipped		No Brake		Brake-Equipped		No Brake		Brake-Equipped		No Brake		Brake-Equipped	
L	229	254	269.5	294.5	279	304	319.5	344.5								
A	103	128	153	178												
B	113	138	163	188												
C	135.5	160.5	185.5	210.5												
D	103	128	153	178												
E	1	1	2	2												
F	43	68	43	68												
G	1	1	2	2												
H	4	4	6	6												
J	6	6	8	8												
Weight (kg)	1.2	1.4	1.5	1.7												

② Compatible Controllers

The RCP3 series actuators can operate with the controllers below. Select the controller according to your usage.

Name	External View	Model	Description	Max. Positioning Points	Input Voltage	Power Supply Capacity	Standard Price	See Page
Solenoid Valve Type		PMEC-C-35PI-NP-2-①	Easy-to-use controller, even for beginners	3 points	AC100V AC200V	See P481	-	→ P477
	Splash-Proof Solenoid Valve Type		PSEP-C-35PI-NP-2-0				Operable with same signal as solenoid valve. Supports both single and double solenoid types. No homing necessary with simple absolute type.	-
Positioner Type			PCON-C-35PI-NP-2-0	Positioning is possible for up to 512 points	512 points	DC24V	2A max.	-
	PCON-CG-35PI-NP-2-0		-					
Pulse Train Input Type (Differential Line Driver)		PCON-PL-35PI-NP-2-0	Pulse train input type with differential line driver support	(-)	DC24V	2A max.	-	→ P525
Pulse Train Input Type (Open Collector)		PCON-PO-35PI-NP-2-0	Pulse train input type with open collector support				-	
Serial Communication Type		PCON-SE-35PI-N-0-0	Dedicated to serial communication	64 points			-	
Field Network Type		RPCON-35P	Dedicated to field network	768 points			-	→ P503
Program Control Type		PSEL-C-1-35PI-NP-2-0	Programmed operation is possible. Operation is possible on up to 2 axes	1500 points			-	→ P557

\* This is for the single-axis PSEL.  
 \* ① is a placeholder for the power supply voltage (1: 100V, 2: 100~240V).

- Slider Type
- Mini
- Standard
- Controllers Integrated
- Rod Type
- Mini
- Standard
- Controllers Integrated
- Table/Arm /Flat Type
- Mini
- Standard
- Gripper/ Rotary Type
- Linear Servo Type
- Cleanroom Type
- Splash Proof
- Controllers
- PMEC /AMEC
- PSEP /ASEP
- ROBO NET
- ERC2
- PCON
- ACON
- SCON
- PSEL
- ASEL
- SSEL
- XSEL
- Pulse Motor
- Servo Motor (24V)
- Servo Motor (200V)
- Linear Servo Motor



# RCP3-TA6C

ROBO Cylinder Table Type Motor Unit Coupled 65mm Width Pulse Motor Ball Screw

■ Configuration: **RCP3** — **TA6C** — **I** — **42P** —  —  —  —  —

Series — Type — Encoder — Motor — Lead — Stroke — Compatible Controllers — Cable Length — Option

I: Incremental  
\* The simple absolute encoder is also considered type "I".

42P: Pulse motor  
42  size

12: 12mm  
6: 6mm  
3: 3mm

25: 25mm  
150: 150mm (25mm pitch increments)

P1: PCON  
RPCON  
PSEL

P3: PMEC  
PSEP

N: None  
P: 1m  
S: 3m  
M: 5m  
X : Custom

See Options below

\* See page Pre-35 for an explanation of the naming convention.

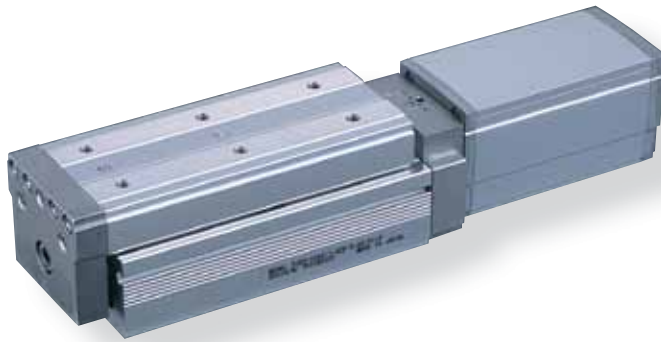

Technical References P. A-5

- POINT**  
Notes on Selection
- (1) Since the RCP3 series use a pulse motor, the load capacity decreases at high speeds. Check in the Speed vs. Load Capacity graph to see if your desired speed and load capacity are supported.
  - (2) Please note that the maximum speed is different when used horizontally versus vertically.
  - (3) The load capacity is based on operation at an acceleration of 0.3G (0.2G for the 3mm-lead model, or when used vertically). This is the upper limit of the acceleration.

### Speed vs. Load Capacity

Due to the characteristics of the Pulse motor, the RCP3 series' load capacity decreases at high speeds. In the table below, check if your desired speed and load capacity are supported.

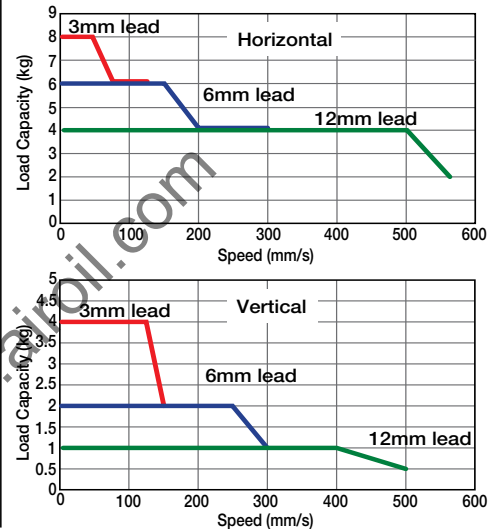

### Actuator Specifications

#### Lead and Load Capacity

(Note 1) Please note that the maximum load capacity decreases as the speed increases.

Model	Lead (mm)	Max. Load Capacity (Note 1)		Maximum Push Force (N)(Note 2)	Stroke (mm)
		Horizontal (kg)	Vertical (kg)		
RCP3-TA6C-I-42P-12-①-②-③-④	12	~4	~1	47	25~150 (25mm increments)
RCP3-TA6C-I-42P-6-①-②-③-④	6	~6	~2	95	
RCP3-TA6C-I-42P-3-①-②-③-④	3	~8	~4	189	

Legend ① Stroke ② Compatible controller ③ Cable length ④ Options

(Note 2) See page A-66 for pushing force graphs.

#### Stroke and Maximum Speed

Stroke / Lead	25 ~ 150 (25mm increments)	
	12	560 <500>
6	300	
3	150	

(Unit: mm/s)

#### ① Stroke List

Stroke (mm)	Standard Price
25	-
50	-
75	-
100	-
125	-
150	-

#### ③ Cable List

Type	Cable Symbol	Standard Price
Standard (Robot Cables)	P (1m)	-
	S (3m)	-
	M (5m)	-
Special Lengths	X06 (6m) ~ X10 (10m)	-
	X11 (11m) ~ X15 (15m)	-
	X16 (16m) ~ X20 (20m)	-
		-

\* The standard cable is the motor-encoder integrated robot cable.

\* See page A-39 for cables for maintenance.

#### ④ Option List

Name	Option Code	Standard Price	Standard Price
Brake	B	→ A-25	-
Cable exit direction (Top)	CJT	→ A-25	-
Cable exit direction (Right)	CJR	→ A-25	-
Cable exit direction (Left)	CJL	→ A-25	-
Cable exit direction (Bottom)	CJB	→ A-25	-
Reversed-home	NM	→ A-33	-

#### Actuator Specifications

Item	Description
Drive System	Ball screw $\phi$ 10mm C10 grade
Positioning Repeatability	$\pm$ 0.02mm
Lost Motion	0.1mm or less
Base	Material: Aluminum (special alumite treated)
Allowable Static Moment	Ma: 29.4 N·m Mb: 42.0 N·m Mc: 74.1 N·m
Allowable Dynamic Moment (*)	Ma: 7.26 N·m Mb: 10.3 N·m Mc: 18.25 N·m
Overhang Load Length	Within the load moment range
Ambient Operating Temp./Humidity	0~40°C, 85% RH or less (non-condensing)

(\*) Based on a 5,000km service life.

Directions of Allowable Load Moments



Dimensions

CAD drawings can be downloaded from IAI website. [www.intelligentactuator.com](http://www.intelligentactuator.com)

For Special Orders P. A-9

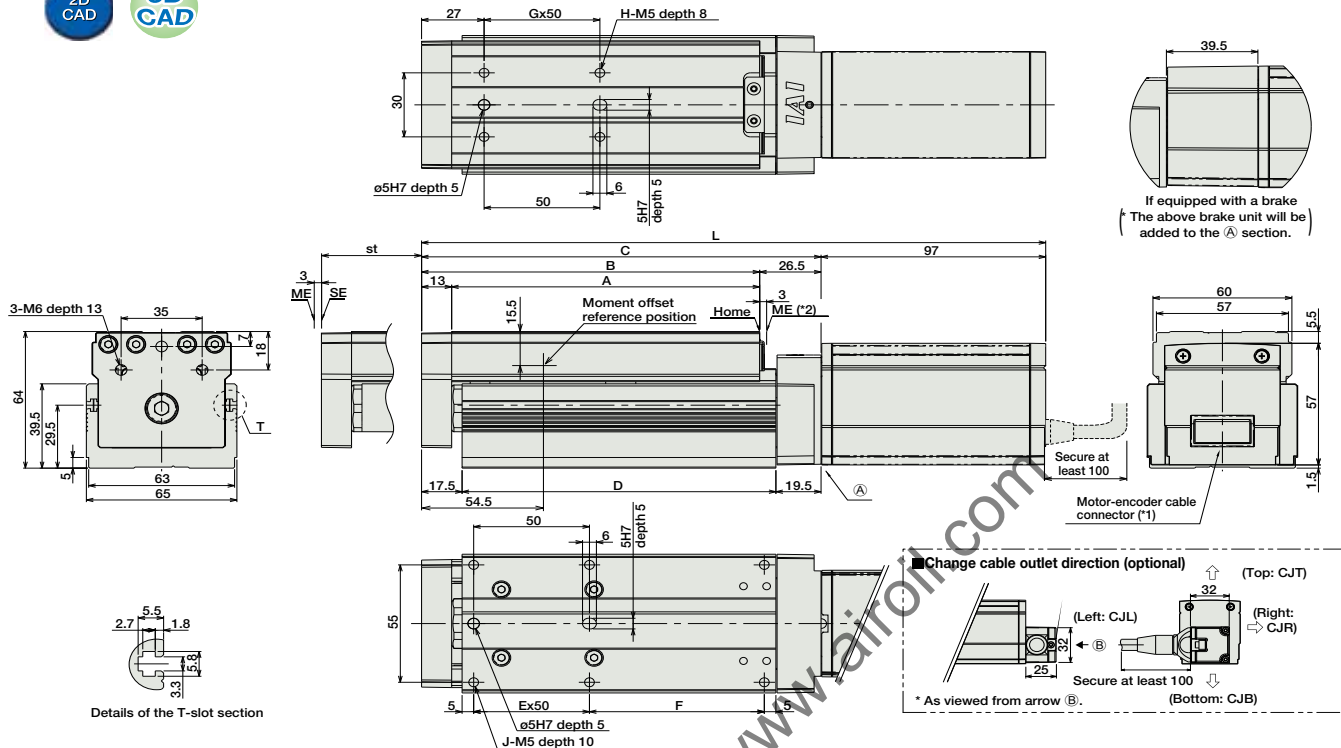

■ Dimensions/Weight by Stroke \* Adding a brake will increase the actuator's weight by 0.4kg.

Stroke	L	Stroke					
		25	50	75	100	125	150
L	No Brake	244.5	269.5	294.5	319.5	344.5	369.5
	Brake-Equipped	284	309	334	359	384	409
A		108	133	158	183	208	233
B		121	146	171	196	221	246
C		147.5	172.5	197.5	222.5	247.5	272.5
D		110.5	135.5	160.5	185.5	210.5	235.5
E		1	1	2	2	3	3
F		50.5	75.5	50.5	75.5	50.5	75.5
G		1	1	2	2	3	3
H		4	4	6	6	8	8
J		6	6	8	8	10	10
Weight (kg)		1.8	2	2.2	2.4	2.6	2.8

(\*1) The motor-encoder cable (integrated) is connected. (See page A-39 for details on cables.)  
 (\*2) After homing, the slider moves to the ME; therefore, please watch for any interference with the surrounding objects.  
 ME: Mechanical end  
 SE: Stroke end

② Compatible Controllers

The RCP3 series actuators can operate with the controllers below. Select the controller according to your usage.

Name	External View	Model	Description	Max. Positioning Points	Input Voltage	Power Supply Capacity	Standard Price	See Page
Solenoid Valve Type		PMEC-C-42PI-NP-2-①	Easy-to-use controller, even for beginners	3 points	AC100V AC200V	See P481	-	→ P477
		PSEP-C-42PI-NP-2-0	Operable with same signal as solenoid valve. Supports both single and double solenoid types. No homing necessary with simple absolute type.					
Splash-Proof Solenoid Valve Type		PSEP-CW-42PI-NP-2-0						→ P487
Positioner Type		PCON-C-42PI-NP-2-0	Positioning is possible for up to 512 points	512 points			-	
Safety-Compliant Positioner Type		PCON-CG-42PI-NP-2-0						
Pulse Train Input Type (Differential Line Driver)		PCON-PL-42PI-NP-2-0	Pulse train input type with differential line driver support	(-)	DC24V	2A max.	-	→ P525
Pulse Train Input Type (Open Collector)		PCON-PO-42PI-NP-2-0	Pulse train input type with open collector support					
Serial Communication Type		PCON-SE-42PI-N-0-0	Dedicated to serial communication	64 points				
Field Network Type		RPCON-42P	Dedicated to field network	768 points				→ P503
Program Control Type		PSEL-C-1-42PI-NP-2-0	Programmed operation is possible. Operation is possible on up to 2 axes	1500 points				→ P557

\* This is for the single-axis PSEL.  
 \* ① is a placeholder for the power supply voltage (1: 100V, 2: 100~240V).

# RCP3-TA7C

ROBO Cylinder Table Type Motor Unit Coupled 75mm Width Pulse Motor Ball Screw

■ Configuration: **RCP3** — **TA7C** — **I** — **42P** —  —  —  —  —

Series — Type — Encoder — Motor — Lead — Stroke — Compatible Controllers — Cable Length — Option

I: Incremental  
\* The simple absolute encoder is also considered type "I".

42P: Pulse motor  
42 □ size

12: 12mm  
6: 6mm  
3: 3mm

25: 25mm  
200: 200mm (25mm pitch increments)

P1: PCON  
RPCON  
PSEL

P3: PMEC  
PSEP

N : None  
P : 1m  
S : 3m  
M : 5m  
X □ □ : Custom

See Options below

\* See page Pre-35 for an explanation of the naming convention.

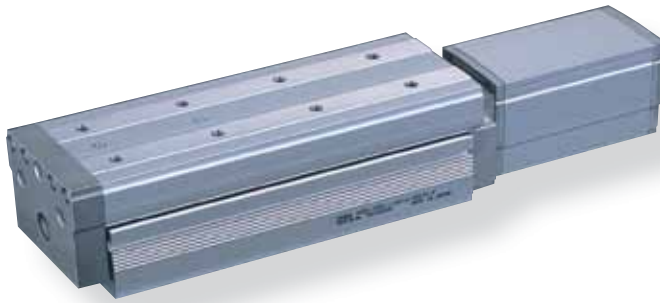

Technical References P. A-5

- POINT**  
Notes on Selection
- (1) Since the RCP3 series use a pulse motor, the load capacity decreases at high speeds. Check in the Speed vs. Load Capacity graph below to see if your desired speed and load capacity are supported.
  - (2) Please note that the maximum speed is different when used horizontally versus vertically.
  - (3) The load capacity is based on operation at an acceleration of 0.3G (0.2G for the 3mm-lead model, or when used vertically). This is the upper limit of the acceleration.

■ Speed vs. Load Capacity  
Due to the characteristics of the Pulse motor, the RCP3 series' load capacity decreases at high speeds. In the table below, check if your desired speed and load capacity are supported.

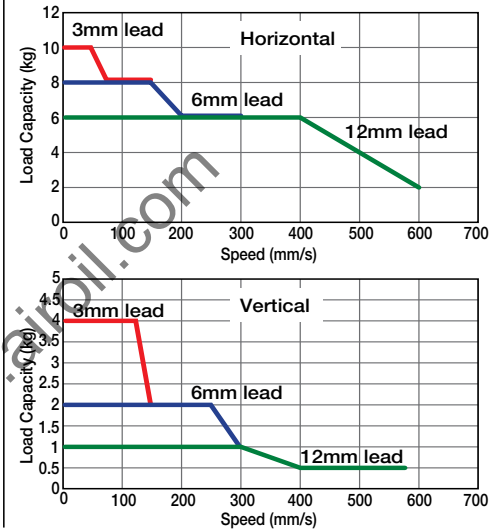

**Actuator Specifications**

■ Lead and Load Capacity (Note 1) Please note that the maximum load capacity decreases as the speed increases.

Model	Lead (mm)	Max. Load Capacity (Note 1)		Maximum Push Force (N) (Note 2)	Stroke (mm)
		Horizontal (kg)	Vertical (kg)		
RCP3-TA7C-I-42P-12-①-②-③-④	12	~ 6	~ 1	47	25~200 (25mm increments)
RCP3-TA7C-I-42P-6-①-②-③-④	6	~ 8	~ 2	95	
RCP3-TA7C-I-42P-3-①-②-③-④	3	~ 10	~ 4	189	

Legend ① Stroke ② Compatible controller ③ Cable length ④ Options (Note 2) See page A-66 for pushing force graphs. (Unit: mm/s)

■ Stroke and Maximum Speed

Stroke / Lead	25 ~ 200 (25mm increments)
12	600 <580>
6	300
3	150

① Stroke List

Stroke (mm)	Standard Price
25	-
50	-
75	-
100	-
125	-
150	-
175	-
200	-

③ Cable List

Type	Cable Symbol	Standard Price
Standard (Robot Cables)	P (1m)	-
	S (3m)	-
	M (5m)	-
Special Lengths	X06 (6m) ~ X10 (10m)	-
	X11 (11m) ~ X15 (15m)	-
	X16 (16m) ~ X20 (20m)	-

\* The standard cable is the motor-encoder integrated robot cable.  
\* See page A-39 for cables for maintenance.

④ Option List

Name	Option Code	Standard Price	Standard Price
Brake	B	→ A-25	-
Cable exit direction (Top)	CJT	→ A-25	-
Cable exit direction (Right)	CJR	→ A-25	-
Cable exit direction (Left)	CJL	→ A-25	-
Cable exit direction (Bottom)	CJB	→ A-25	-
Reversed-home	NM	→ A-33	-

**Actuator Specifications**

Item	Description
Drive System	Ball screw ø10mm C10 grade
Positioning Repeatability	±0.02mm
Lost Motion	0.1mm or less
Base	Material: Material: Aluminum (special alumite treated)
Allowable Static Moment	Ma: 42.6 N·m Mb: 60.8 N·m Mc: 123.2 N·m
Allowable Dynamic Moment (*)	Ma: 9.91 N·m Mb: 14.13 N·m Mc: 28.65 N·m
Overhang Load Length	Within the load moment range
Ambient Operating Temp./Humidity	0~40°C, 85% RH or less (non-condensing)

(\*) Based on a 5,000km service life.

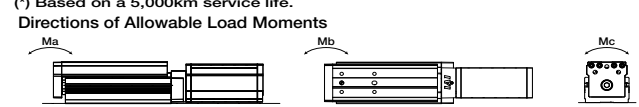

Dimensions

CAD drawings can be downloaded from IAI website. [www.intelligentactuator.com](http://www.intelligentactuator.com)



For Special Orders P. A-9

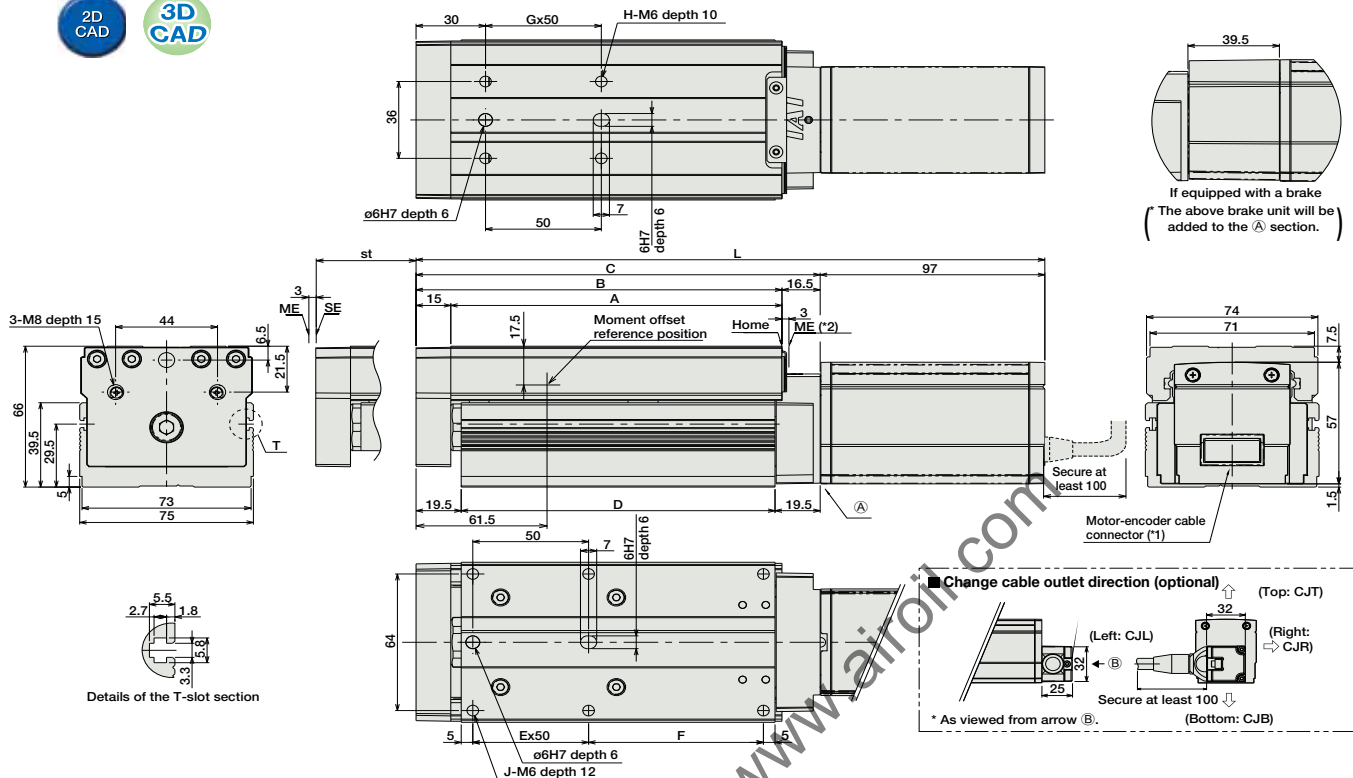

(\*1) The motor-encoder cable (integrated) is connected. (See page A-39 for details on cables.)  
 (\*2) After homing, the slider moves to the ME; therefore, please watch for any interference with the surrounding objects.  
 ME: Mechanical end  
 SE: Stroke end

■ Dimensions/Weight by Stroke \* Adding a brake will increase the actuator's weight by 0.4kg.

Stroke	Stroke								
	25	50	75	100	125	150	175	200	
L	No Brake	246.5	271.5	296.5	321.5	346.5	371.5	396.5	421.5
	Brake-Equipped	286	311	336	361	386	411	436	461
A	118	143	168	193	218	243	268	293	
B	133	158	183	208	233	258	283	308	
C	149.5	174.5	199.5	224.5	249.5	274.5	299.5	324.5	
D	110.5	135.5	160.5	185.5	210.5	235.5	260.5	285.5	
E	1	1	2	2	3	3	4	4	
F	50.5	75.5	50.5	75.5	50.5	75.5	50.5	75.5	
G	1	1	2	2	3	3	4	4	
H	4	4	6	6	8	8	10	10	
J	6	6	8	8	10	10	12	12	
Weight (kg)	2.1	2.3	2.5	2.8	3	3.2	3.4	3.6	

② Compatible Controllers

The RCP3 series actuators can operate with the controllers below. Select the controller according to your usage.

Name	External View	Model	Description	Max. Positioning Points	Input Voltage	Power Supply Capacity	Standard Price	See Page
Solenoid Valve Type		PMEC-C-42PI-NP-2-①	Easy-to-use controller, even for beginners	3 points	AC100V AC200V	See P481	-	→ P477
		PSEP-C-42PI-NP-2-0	Operable with same signal as solenoid valve. Supports both single and double solenoid types. No homing necessary with simple absolute type.					
Splash-Proof Solenoid Valve Type		PSEP-CW-42PI-NP-2-0						→ P487
Positioner Type		PCON-C-42PI-NP-2-0	Positioning is possible for up to 512 points	512 points				
Safety-Compliant Positioner Type		PCON-CG-42PI-NP-2-0						
Pulse Train Input Type (Differential Line Driver)		PCON-PL-42PI-NP-2-0	Pulse train input type with differential line driver support	(-)	DC24V	2A max.		→ P525
Pulse Train Input Type (Open Collector)		PCON-PO-42PI-NP-2-0	Pulse train input type with open collector support					
Serial Communication Type		PCON-SE-42PI-N-0-0	Dedicated to serial communication	64 points				
Field Network Type		RPCON-42P	Dedicated to field network	768 points				→ P503
Program Control Type		PSEL-C-1-42PI-NP-2-0	Programmed operation is possible. Operation is possible on up to 2 axes	1500 points				→ P557

\* This is for the single-axis PSEL.  
 \* ① is a placeholder for the power supply voltage (1: 100V, 2: 100~240V).

- Slider Type
- Mini
- Standard
- Controllers Integrated
- Rod Type
- Mini
- Standard
- Controllers Integrated
- Table/Arm/Flat Type
- Mini
- Standard
- Gripper/Rotary Type
- Linear Servo Type
- Cleanroom Type
- Splash Proof
- Controllers
- PMEC/AMEC
- PSEP/ASEP
- ROBO NET
- ERC2
- PCON
- ACON
- SCON
- PSEL
- ASEL
- SSEL
- XSEL
- Pulse Motor
- Servo Motor (24V)
- Servo Motor (200V)
- Linear Servo Motor

# RCP3-TA3R

ROBO Cylinder Mini Table Type Side-Mounted Motor 36mm Width Pulse Motor Ball Screw

■ Configuration: **RCP3** — **TA3R** — **I** — **20P** —  —  —  —  —

Series	Type	Encoder	Motor	Lead	Stroke	Compatible Controllers	Cable Length	Option
		I: Incremental * The simple absolute encoder is also considered type "I".	20P: Pulse motor 20 <input type="checkbox"/> size	6: 6mm 4: 4mm 2: 2mm	20: 20mm ↓ 100: 100mm (10mm pitch increments)	P1: PCON RPCON PSEL P3: PMEC PSEP	N : None P : 1m S : 3m M : 5m X <input type="checkbox"/> <input type="checkbox"/> : Custom	See Options below * Be sure to specify which side the motor is to be mounted (ML/MR).

\* See page Pre-35 for an explanation of the naming convention.



Pictured: Left-mounted motor model (ML).

Technical References P. A-5



(1) The load capacity is based on operation at an acceleration of 0.3G (0.2G for the 2mm lead model, or when used vertically). 0.3G (0.2G for 2mm lead) is the upper limit of the acceleration.

### Speed vs. Load Capacity

Due to the characteristics of the Pulse motor, the RCP3 series' load capacity decreases at high speeds. In the table below, check if your desired speed and load capacity are supported.

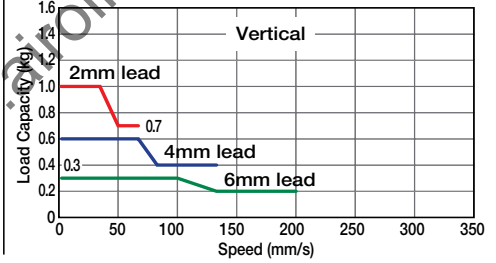
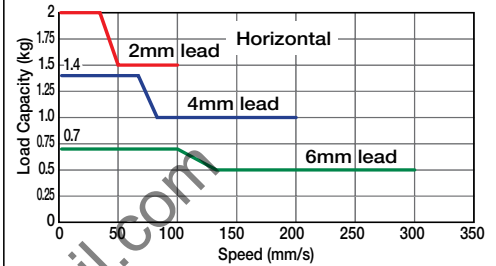

### Actuator Specifications

#### Lead and Load Capacity

(Note 1) Please note that the maximum load capacity decreases as the speed increases.

Model	Feed Screw	Lead (mm)	Mx. Load Capacity (Note 1)		Maximum Push Force (N) (Note 2)	Positioning Repeatability (mm)	Stroke (mm)
			Horizontal (kg)	Vertical (kg)			
RCP3-TA3R-I-20P-6-①-②-③-④	Ball Screw	6	~ 0.7	~ 0.3	9	±0.02	20~100 (10mm increments)
RCP3-TA3R-I-20P-4-①-②-③-④		4	~ 1.4	~ 0.6	14		
RCP3-TA3R-I-20P-2-①-②-③-④		2	~ 2	~ 1	28		

Legend ① Stroke ② Compatible controller ③ Cable length ④ Options

(Note 2) See page A-66 for pushing force factors.

#### Stroke and Maximum Speed

Lead	Stroke	20 ~ 100 (mm)
	Ball Screw	6
4		200 <133>
2		100 <67>

\* The values enclosed in "<" ">" apply to vertical usage. (Unit: mm/s)

#### ① Stroke List

Stroke (mm)	Standard Price
20	-
30	-
40	-
50	-
60	-
70	-
80	-
90	-
100	-

#### ③ Cable List

Type	Cable Symbol	Standard Price
Standard (Robot Cables)	P (1m)	-
	S (3m)	-
	M (5m)	-
Special Lengths	X06 (6m) ~ X10 (10m)	-
	X11 (11m) ~ X15 (15m)	-
	X16 (16m) ~ X20 (20m)	-

\* The RCP3 comes standard with a robot cable.

\* See page A-39 for cables for maintenance.

#### ④ Option List

Name	Option Code	See Page	Standard Price
Brake	B	→ A-25	-
Left-Mounted Motor (Standard)	ML	→ A-33	-
Right-Mounted Motor	MR	→ A-33	-
Reversed-home	NM	→ A-33	-

#### Actuator Specifications

Item	Description
Drive System	Ball screw ø6mm C10 grade
Lost Motion	0.1mm or less
Base	Material: Aluminum (white alumite treated)
Allowable Dynamic Moment (Note 3)	Ma: 3.2 N·m Mb: 4.6 N·m Mc: 5.1 N·m
Ambient Operating Temp./Humidity	0~40°C, 85% RH or less (non-condensing)

(Note 3) Based on a 5,000km service life.

#### Directions of Allowable Load Moments



Dimensions

CAD drawings can be downloaded from IAI website. [www.intelligentactuator.com](http://www.intelligentactuator.com)

For Special Orders P. A-9



\* Below is a drawing of the left-mounted motor model.

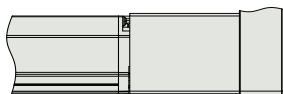

If brake-equipped: (See right for dimensions)

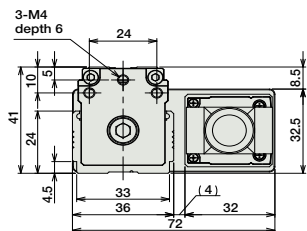
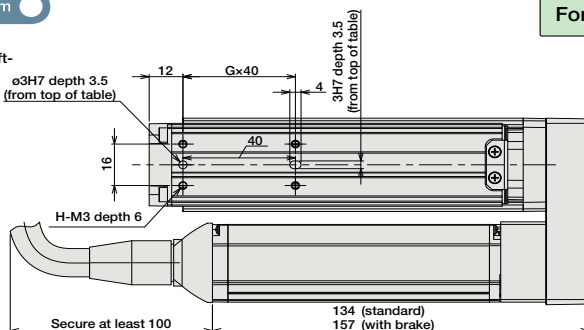

The offset reference position of the moment is the same as TA3C (P270).

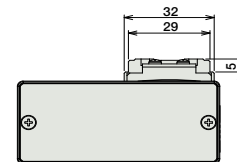
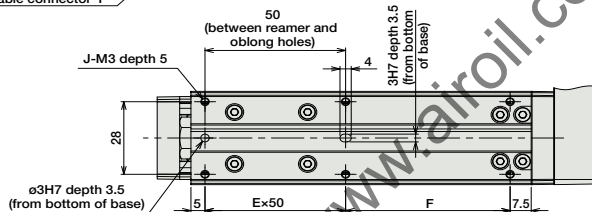
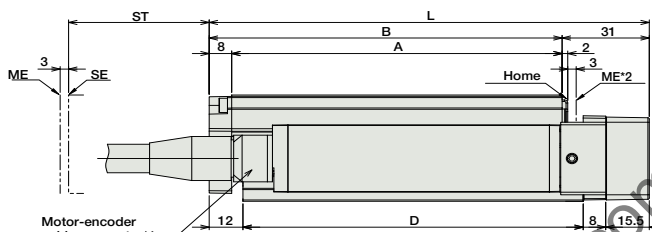

ST : Stroke  
ME : Mechanical end  
SE : Stroke end

- \*1 The motor-encoder cable is connected directly to the motor cover of the actuator. See page A-39 for details on cables.
- \*2 When homing, the slider moves to the mechanical end; therefore, please watch for any interference with the surrounding objects.

■ Dimensions/Weight by Stroke

\* Adding a brake will increase the actuator's weight by 0.1kg.

Stroke	20	30	40	50	60	70	80	90	100
L	126.5	136.5	146.5	156.5	166.5	176.5	186.5	196.5	206.5
A	87.5	97.5	107.5	117.5	127.5	137.5	147.5	157.5	167.5
B	95.5	105.5	115.5	125.5	135.5	145.5	155.5	165.5	175.5
D	91	101	111	121	131	141	151	161	171
E	1	1	1	1	2	2	2	2	2
F	28.5	38.5	48.5	58.5	68.5	78.5	88.5	98.5	108.5
G	1	1	1	1	2	2	2	2	2
H	4	4	4	4	6	6	6	6	6
J	6	6	6	6	8	8	8	8	8
Weight (kg)	0.5	0.6	0.6	0.6	0.6	0.7	0.7	0.7	0.7

② Compatible Controllers

The RCP3 series actuators can operate with the controllers below. Select the controller according to your usage.

Name	External View	Model	Description	Max. Positioning Points	Input Voltage	Power Supply Capacity	Standard Price	See Page
Solenoid Valve Type		PMEC-C-20PI-NP-2-①	Easy-to-use controller, even for beginners	3 points	AC100V AC200V	See P481	-	→ P477
		PSEP-C-20PI-NP-2-0	Operable with same signal as solenoid valve. Supports both single and double solenoid types. No homing necessary with simple absolute type.					
Splash-Proof Solenoid Valve Type		PSEP-CW-20PI-NP-2-0						
Positioner Type		PCON-C-20PI-NP-2-0	Positioning is possible for up to 512 points	512 points	DC24V	2A max.	-	→ P525
Safety-Compliant Positioner Type		PCON-CG-20PI-NP-2-0						
Pulse Train Input Type (Differential Line Driver)		PCON-PL-20PI-NP-2-0	Pulse train input type with different line driver support	(-)	DC24V	2A max.	-	→ P525
Pulse Train Input Type (Open Collector)		PCON-PO-20PI-NP-2-0	Pulse train input type with open collector support					
Serial Communication Type		PCON-SE-20PI-N-0-0	Dedicated to serial communication	64 points	DC24V	2A max.	-	→ P503
Field Network Type		RPCON-20P	Dedicated to field network	768 points				
Program Control Type		PSEL-C-1-20PI-NP-2-0	Programmed operation is possible. Operation is possible on up to 2 axes	1500 points	DC24V	2A max.	-	→ P557

\* This is for the single-axis PSEL.

\* ① is a placeholder for the power supply voltage (1: 100V, 2: 100~240V).

# RCP3-TA4R

ROBO Cylinder Mini Table Type Side-Mounted Motor 40mm Width Pulse Motor Ball Screw

■ Configuration: **RCP3** — **TA4R** — **I** — **28P** —  —  —  —  —

Series	Type	Encoder	Motor	Lead	Stroke	Compatible Controllers	Cable Length	Option
RCP3	TA4R	I: Incremental * The simple absolute encoder is also considered type "I".	28P: Pulse motor 28 <input type="checkbox"/> size	6 : 6mm 4 : 4mm 2 : 2mm	20: 20mm 100: 100mm (10mm pitch increments)	P1: PCON RPCON PSEL P3: PMEC PSEP	N : None P : 1m S : 3m M : 5m X <input type="checkbox"/> : Custom	See Options below * Be sure to specify which side the motor is to be mounted (ML/MR).

\* See page Pre-35 for an explanation of the naming convention.



Pictured: TA3R with left-mounted motor (ML).

Technical References P. A-5



(1) The load capacity is based on operation at an acceleration of 0.3G (0.2G for the 2mm lead model, or when used vertically). 0.3G (0.2G for 2mm lead) is the upper limit of the acceleration.

### Speed vs. Load Capacity

Due to the characteristics of the Pulse motor, the RCP3 series' load capacity decreases at high speeds. In the table below, check if your desired speed and load capacity are supported.

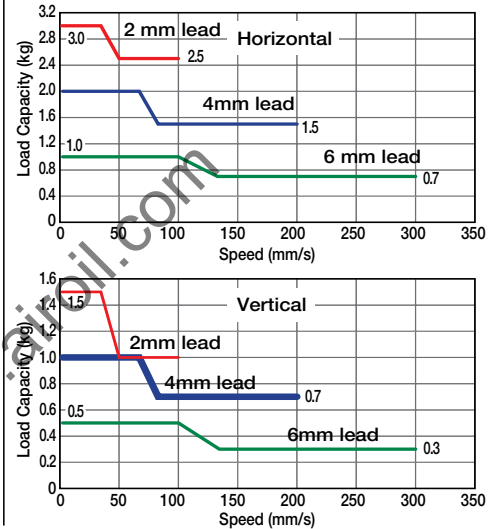

### Actuator Specifications

#### Lead and Load Capacity

(Note 1) Please note that the maximum load capacity decreases as the speed increases.

#### Stroke and Maximum Speed

Model	Feed Screw	Lead (mm)	Mx. Load Capacity (Note 1) Horizontal (kg) Vertical (kg)	Maximum Push Force (N) (Note 2)	Positioning Repeatability (mm)	Stroke (mm)
RCP3-TA4R-I-28P-6-①-②-③-④	Ball Screw	6	~ 1 ~ 0.5	15	±0.02	20~100 (10mm increments)
RCP3-TA4R-I-28P-4-①-②-③-④		4	~ 2 ~ 1	22		
RCP3-TA4R-I-28P-2-①-②-③-④		2	~ 3 ~ 1.5	44		

Lead	Stroke	20 ~ 100 (mm)
	6	300
4	200	
2	100	

Legend ① Stroke ② Compatible controller ③ Cable length ④ Options

(Note 2) See page A-66 for pushing force graphs.

(Unit: mm/s)

#### ① Stroke List

Stroke (mm)	Standard Price
20	-
30	-
40	-
50	-
60	-
70	-
80	-
90	-
100	-

#### ③ Cable List

Type	Cable Symbol	Standard Price
Standard (Robot Cables)	P (1m)	-
	S (3m)	-
	M (5m)	-
Special Lengths	X06 (6m) ~ X10 (10m)	-
	X11 (11m) ~ X15 (15m)	-
	X16 (16m) ~ X20 (20m)	-

\* The RCP3 comes standard with a robot cable.  
\* See page A-39 for cables for maintenance.

#### ④ Option List

Name	Option Code	See Page	Standard Price
Brake	B	→ A-25	-
Cable exit direction (Top)	CJT	→ A-25	-
Cable exit direction (Outside)	CJO		
Cable exit direction (Bottom)	CJB		
Cable exit direction (Standard)	ML		
Left-Mounted Motor	ML	→ A-33	-
Right-Mounted Motor	MR	→ A-33	-
Reversed-home	NM	→ A-33	-

#### Actuator Specifications

Item	Description
Drive System	Ball screw ø6mm C10 grade
Lost Motion	0.1mm or less
Base	Material: Aluminum (white alumite treated)
Allowable Dynamic Moment (Note 3)	Ma: 4.2 N·m Mb: 6 N·m Mc: 8.2 N·m
Ambient Operating Temp./Humidity	0~40°C, 85% RH or less (non-condensing)

(Note 3) Based on a 5,000km service life.

Directions of Allowable Load Moments

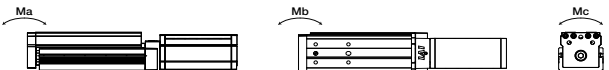

Dimensions

CAD drawings can be downloaded from IAI website. [www.intelligentactuator.com](http://www.intelligentactuator.com)

For Special Orders P. A-9



\* Below is a drawing of the left-mounted motor model.

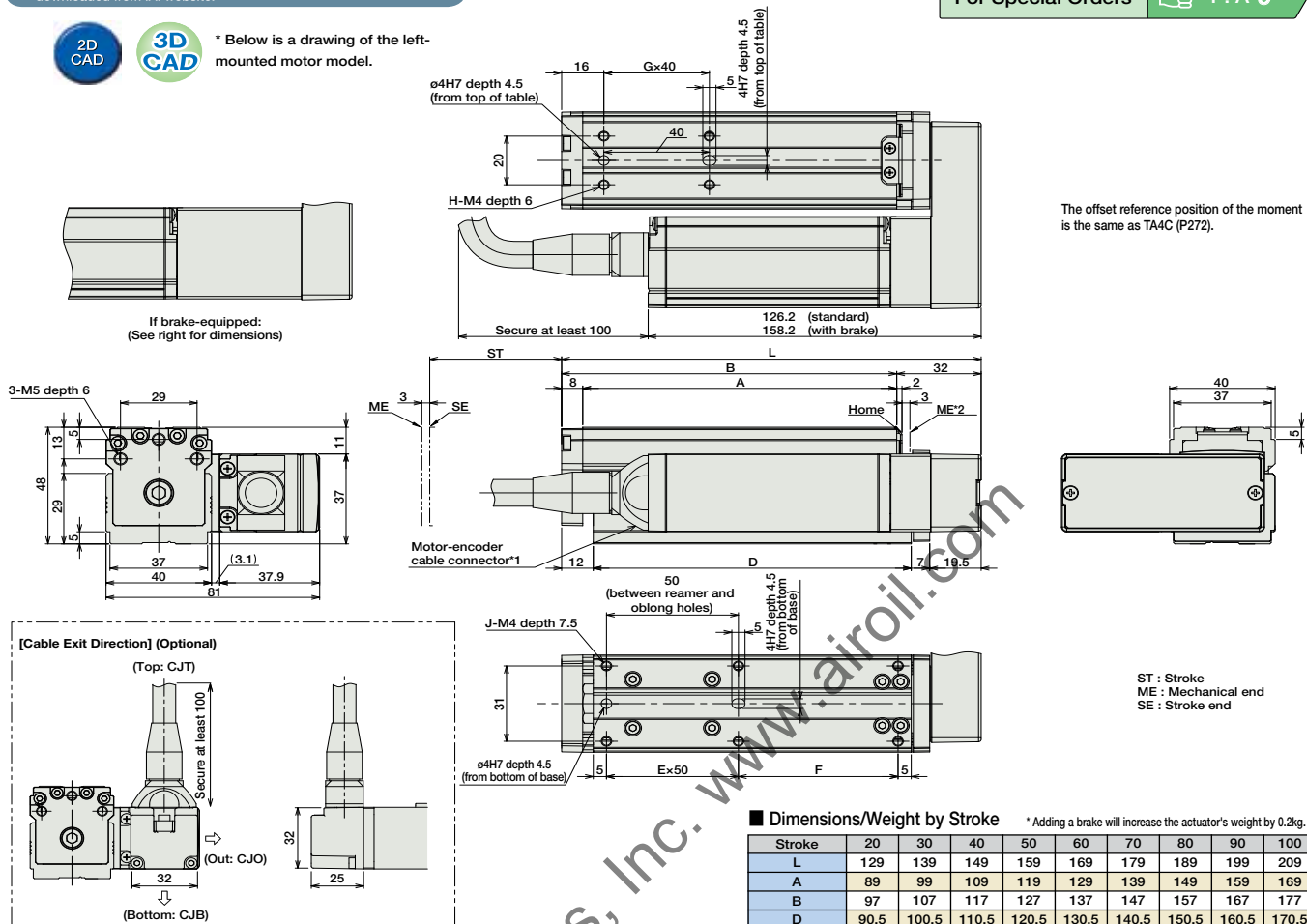

\*1 The motor-encoder cable is connected directly to the motor cover of the actuator. See page A-39 for details on cables.  
\*2 When homing, the slider moves to the mechanical end; therefore, please watch for any interference with the surrounding objects.

■ Dimensions/Weight by Stroke \* Adding a brake will increase the actuator's weight by 0.2kg.

Stroke	20	30	40	50	60	70	80	90	100
L	129	139	149	159	169	179	189	199	209
A	89	99	109	119	129	139	149	159	169
B	97	107	117	127	137	147	157	167	177
D	90.5	100.5	110.5	120.5	130.5	140.5	150.5	160.5	170.5
E	1	1	1	1	2	2	2	2	2
F	30.5	40.5	50.5	60.5	20.5	30.5	40.5	50.5	60.5
G	1	1	1	1	2	2	2	2	2
H	4	4	4	4	6	6	6	6	6
J	6	6	6	6	8	8	8	8	8
Weight (kg)	0.7	0.8	0.8	0.8	0.9	0.9	0.9	1.0	1.0

② Compatible Controllers

The RCP3 series actuators can operate with the controllers below. Select the controller according to your usage.

Name	External View	Model	Description	Max. Positioning Points	Input Voltage	Power Supply Capacity	Standard Price	See Page
Solenoid Valve Type		PMEC-C-28PI-NP-2-①	Easy-to-use controller, even for beginners	3 points	AC100V AC200V	See P481	-	→ P477
		PSEP-C-28PI-NP-2-0	Operable with same signal as solenoid valve. Supports both single and double solenoid types. No homing necessary with simple absolute type.					
Splash-Proof Solenoid Valve Type		PSEP-CW-28PI-NP-2-0						
Positioner Type		PCON-C-28PI-NP-2-0	Positioning is possible for up to 512 points	512 points	DC24V	2A max.	-	→ P525
Safety-Compliant Positioner Type		PCON-CG-28PI-NP-2-0						
Pulse Train Input Type (Differential Line Driver)		PCON-PL-28PI-NP-2-0	Pulse train input type with different line driver support	(-)	DC24V	2A max.	-	→ P525
Pulse Train Input Type (Open Collector)		PCON-PO-28PI-NP-2-0	Pulse train input type with open collector support					
Serial Communication Type		PCON-SE-28PI-N-0-0	Dedicated to serial communication	64 points				
Field Network Type		RPCON-28P	Dedicated to field network	768 points				→ P503
Program Control Type		PSEL-C-1-28PI-NP-2-0	Programmed operation is possible. Operation is possible on up to 2 axes	1500 points				→ P557

\* This is for the single-axis PSEL.  
\* ① is a placeholder for the power supply voltage (1: 100V, 2: 100~240V).

- Slider Type
- Mini
- Standard
- Controllers Integrated
- Rod Type
- Mini
- Standard
- Controllers Integrated
- Table/Arm/Flat Type
- Mini
- Standard
- Gripper/Rotary Type
- Linear Servo Type
- Cleanroom Type
- Splash Proof
- Controllers
- PMEC/AMEC
- PSEP/ASEP
- ROBO NET
- ERC2
- PCON
- ACON
- SCON
- PSEL
- ASEL
- SSEL
- XSEL
- Pulse Motor
- Servo Motor (24V)
- Servo Motor (200V)
- Linear Servo Motor



# RCP3-TA5R

ROBO Cylinder Table Type Side-Mounted Motor 55mm Width Pulse Motor Ball Screw

■ Configuration: **RCP3** — **TA5R** — **I** — **35P** —  —  —  —  —

Series — Type — Encoder — Motor — Lead — Stroke — Compatible Controllers — Cable Length — Option

I: Incremental  
\* The simple absolute encoder is also considered type "I".

35P: Pulse motor  
35  size

10: 10mm  
5: 5mm  
2.5: 2.5mm

25: 25mm  
100: 100mm (25mm pitch increments)

P1: PCON  
RPCON  
PSEL  
P3: PMEC  
PSEP

N: None  
P: 1m  
S: 3m  
M: 5m  
X  : Custom

See Options below  
\* Be sure to specify which side the motor is to be mounted (ML/MR).

\* See page Pre-35 for an explanation of the naming convention.



Technical References P. A-5



- (1) Since the RCP3 series use a pulse motor, the load capacity decreases at high speeds. Check in the Speed vs. Load Capacity graph to see if your desired speed and load capacity are supported.
- (2) Please note that the maximum speed is different when used horizontally versus vertically.
- (3) The load capacity is based on operation at an acceleration of 0.3G (0.2G for the 2.5mm-lead model, or when used vertically). This is the upper limit of the acceleration.

■ Speed vs. Load Capacity  
Due to the characteristics of the Pulse motor, the RCP3 series' load capacity decreases at high speeds. In the table below, check if your desired speed and load capacity are supported.

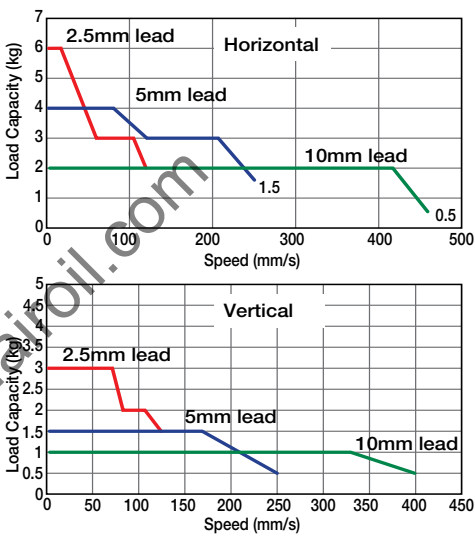

Actuator Specifications					
■ Lead and Load Capacity			■ Stroke and Maximum Speed		
Model	Lead (mm)	Max. Load Capacity		Maximum Push Force (N)	Stroke (mm)
		Horizontal (kg)	Vertical (kg)		
RCP3-TA5R-I-35P-10-①-②-③-④	10	~ 2	~ 1	34	25~100 (25mm increments)
RCP3-TA5R-I-35P-5-①-②-③-④	5	~ 4	~ 1.5	68	
RCP3-TA5R-I-35P-2.5-①-②-③-④	2.5	~ 6	~ 3	136	

Legend ① Stroke ② Compatible controller ③ Cable length ④ Options

Stroke / Lead	25 ~ 100 (25mm increments)
10	465 <400>
5	250
2.5	125

\* The values enclosed in "< >" apply to vertical usage. (Unit: mm/s)

① Stroke List

Stroke (mm)	Standard Price
25	-
50	-
75	-
100	-

③ Cable List

Type	Cable Symbol	Standard Price
Standard (Robot Cables)	P (1m)	-
	S (3m)	-
	M (5m)	-
Special Lengths	X06 (6m) ~ X10 (10m)	-
	X11 (11m) ~ X15 (15m)	-
	X16 (16m) ~ X20 (20m)	-
		-

\* The standard cable is the motor-encoder integrated robot cable.  
\* See page A-39 for cables for maintenance.

④ Option List

Name	Option Code	See Page	Standard Price
Brake	B	→ A-25	-
Cable exit direction (Top)	CJT		
Cable exit direction (Outside)	CJO	→ A-25	-
Cable exit direction (Bottom)	CJB		
Left-Mounted Motor (Standard)	ML	→ A-33	-
Right-Mounted Motor	MR	→ A-33	-
Reversed-home	NM	→ A-33	-

Actuator Specifications

Item	Description
Drive System	Ball screw ø8mm C10 grade
Positioning Repeatability	±0.02mm
Lost Motion	0.1mm or less
Base	Material: Material: Aluminum (special alumite treated)
Allowable Static Load Moment	Ma: 25.5 N·m Mb: 36.5 N·m Mc: 56.1 N·m
Allowable Dynamic Load Moment	Ma: 6.57 N·m Mb: 9.32 N·m Mc: 14.32 N·m
Overhang Load Length	Within the load moment range
Ambient Operating Temp./Humidity	0~40°C, 85% RH or less (non-condensing)

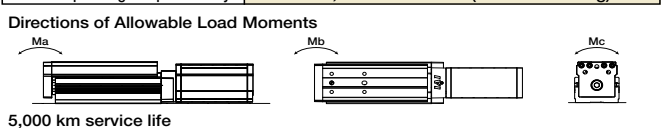

Dimensions

CAD drawings can be downloaded from IAI website. [www.intelligentactuator.com](http://www.intelligentactuator.com)

For Special Orders P. A-9



\* Please note that, for 25mm-stroke model with brake, the motor unit protrudes from the end of the table.

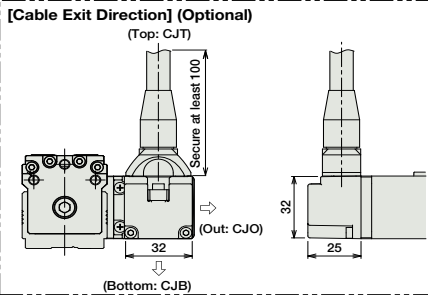
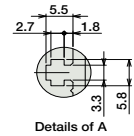
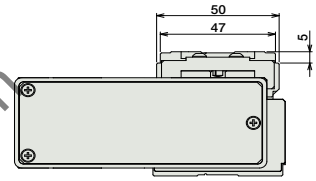
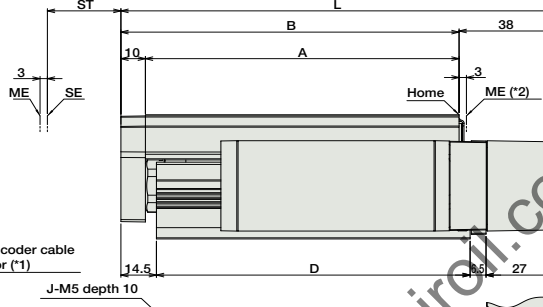
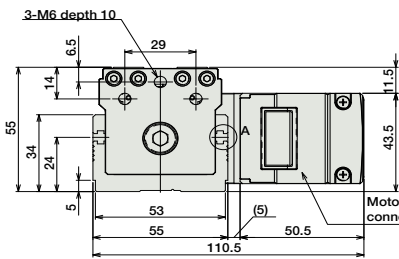
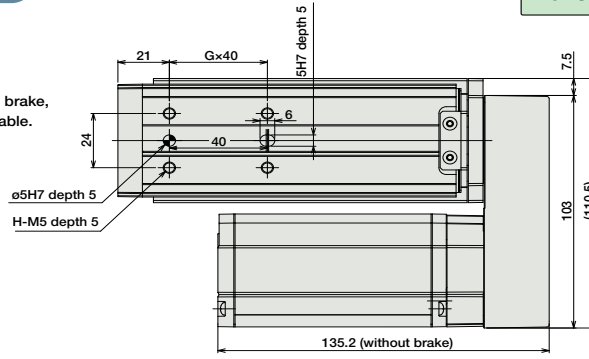
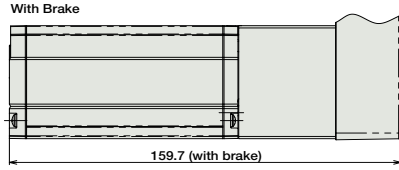

**■ Dimensions/Weight by Stroke**

Stroke	25	50	75	100
L	151	176	201	226
A	103	128	153	178
B	113	138	163	188
D	103	128	153	178
E	1	1	2	2
F	43	68	43	68
G	1	1	2	2
H	4	4	6	6
J	6	6	8	8
Weight (kg)	1.4	1.6	1.7	1.9

\* Adding a brake will increase the weight by 0.3kg.

(\*1) The motor-encoder cable is provided as an integrated cable. (see page A-99)  
 (\*2) After homing, the slider moves to the ME; therefore, please watch for any interference with the surrounding objects.  
 ME: Mechanical end  
 SE: Stroke end

② Compatible Controllers

The RCP3 series actuators can operate with the controllers below. Select the controller according to your usage.

Name	External View	Model	Description	Max. Positioning Points	Input Voltage	Power Supply Capacity	Standard Price	See Page
Solenoid Valve Type		PMEC-C-35PI-NP-2-①	Easy-to-use controller, even for beginners	3 points	AC100V AC200V	See P481	-	→ P477
		PSEP-C-35PI-NP-2-0	Operable with same signal as solenoid valve. Supports both single and double solenoid types. No homing necessary with simple absolute type.					
Splash-Proof Solenoid Valve Type		PSEP-CW-35PI-NP-2-0					-	→ P487
Positioner Type		PCON-C-35PI-NP-2-0	Positioning is possible for up to 512 points	512 points	DC24V	2A max.	-	→ P525
Safety-Compliant Positioner Type		PCON-CG-35PI-NP-2-0						
Pulse Train Input Type (Differential Line Driver)		PCON-PL-35PI-NP-2-0	Pulse train input type with differential line driver support	(-)	DC24V	2A max.	-	→ P525
Pulse Train Input Type (Open Collector)		PCON-PO-35PI-NP-2-0	Pulse train input type with open collector support					
Serial Communication Type		PCON-SE-35PI-N-0-0	Dedicated to serial communication	64 points			-	
Field Network Type		RPCON-35P	Dedicated to field network	768 points			-	→ P503
Program Control Type		PSEL-C-1-35PI-NP-2-0	Programmed operation is possible. Operation is possible on up to 2 axes	1500 points			-	→ P557

\* This is for the single-axis PSEL.  
 \* ① is a placeholder for the power supply voltage (1: 100V, 2: 100~240V).

- Slider Type
- Mini
- Standard
- Controllers Integrated
- Rod Type
- Mini
- Standard
- Controllers Integrated
- Table/Arm/Flat Type
- Mini
- Standard
- Gripper/Rotary Type
- Linear Servo Type
- Cleanroom Type
- Splash Proof
- Controllers
- PMEC/AMEC
- PSEP/ASEP
- ROBO NET
- ERC2
- PCON
- ACON
- SCON
- PSEL
- ASEL
- SSEL
- XSEL
- Pulse Motor
- Servo Motor (24V)
- Servo Motor (200V)
- Linear Servo Motor

# RCP3-TA6R

ROBO Cylinder Table Type Side-Mounted Motor 65mm Width Pulse Motor Ball Screw

■ Configuration: **RCP3** — **TA6R** — **I** — **42P** —  —  —  —  —

Series — Type — Encoder — Motor — Lead — Stroke — Compatible Controllers — Cable Length — Option

I: Incremental  
\* The simple absolute encoder is also considered type "I".

42P: Pulse motor  
42  size

12: 12mm  
6: 6mm  
3: 3mm

25: 25mm  
150: 150mm (25mm pitch increments)

P1: PCON  
RCON  
PSEL  
P3: PMEC  
PSEP

N: None  
P: 1m  
S: 3m  
M: 5m  
X  : Custom

See Options below  
\* Be sure to specify which side the motor is to be mounted (ML/MR).

\* See page Pre-35 for an explanation of the naming convention.

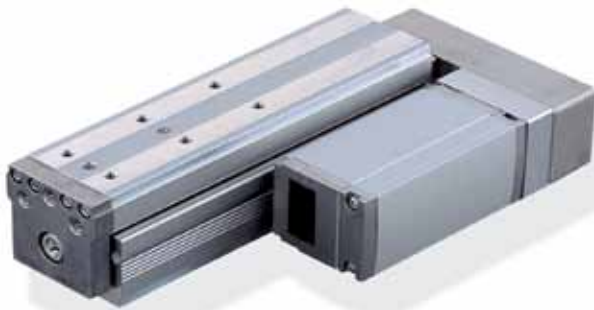

Technical References P. A-5



- (1) Since the RCP3 series use a pulse motor, the load capacity decreases at high speeds. Check in the Speed vs. Load Capacity graph to see if your desired speed and load capacity are supported.
- (2) Please note that the maximum speed is different when used horizontally versus vertically.
- (3) The load capacity is based on operation at an acceleration of 0.3G (0.2G for the 3mm-lead model, or when used vertically). This is the upper limit of the acceleration.

■ Speed vs. Load Capacity  
Due to the characteristics of the Pulse motor, the RCP3 series' load capacity decreases at high speeds. In the table below, check if your desired speed and load capacity are supported.

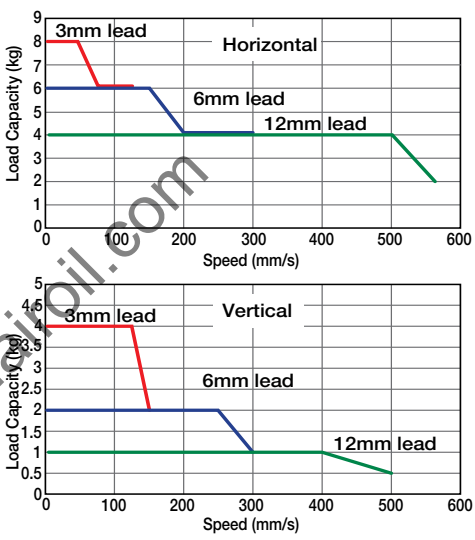

Actuator Specifications				
■ Lead and Load Capacity				
Model	Lead (mm)	Max. Load Capacity		Maximum Push Force (N)
		Horizontal (kg)	Vertical (kg)	
RCP3-TA6R-I-42P-12-①-②-③-④	12	~ 4	~ 1	47
RCP3-TA6R-I-42P-6-①-②-③-④	6	~ 6	~ 2	95
RCP3-TA6R-I-42P-3-①-②-③-④	3	~ 8	~ 4	189

Legend ① Stroke ② Compatible controller ③ Cable length ④ Options

■ Stroke and Maximum Speed	
Stroke / Lead	25 ~ 150 (25mm increments)
12	560 <500>
6	300
3	150

\* The values enclosed in "< >" apply to vertical usage. (Unit: mm/s)

① Stroke List

Stroke (mm)	Standard Price
25	-
50	-
75	-
100	-
125	-
150	-

③ Cable List

Type	Cable Symbol	Standard Price
Standard (Robot Cables)	P (1m)	-
	S (3m)	-
	M (5m)	-
Special Lengths	X06 (6m) ~ X10 (10m)	-
	X11 (11m) ~ X15 (15m)	-
	X16 (16m) ~ X20 (20m)	-
		-

\* The standard cable is the motor-encoder integrated robot cable.  
\* See page A-39 for cables for maintenance.

④ Option List

Name	Option Code	See Page	Standard Price
Brake	B	→ A-25	-
Cable exit direction (Top)	CJT		
Cable exit direction (Outside)	CJO	→ A-25	-
Cable exit direction (Bottom)	CJB		
Left-Mounted Motor (Standard)	ML	→ A-33	-
Right-Mounted Motor	MR	→ A-33	-
Reversed-home	NM	→ A-33	-

Actuator Specifications

Item	Description
Drive System	Ball screw ø10mm C10 grade
Positioning Repeatability	±0.02mm
Lost Motion	0.1mm or less
Base	Material: Material: Aluminum (special alumite treated)
Allowable Static Load Moment	Ma: 29.4 N·m Mb: 42.0 N·m Mc: 74.1 N·m
Allowable Dynamic Load Moment	Ma: 7.26 N·m Mb: 10.3 N·m Mc: 18.25 N·m
Overhang Load Length	Within the load moment range
Ambient Operating Temp./Humidity	0~40°C, 85% RH or less (non-condensing)

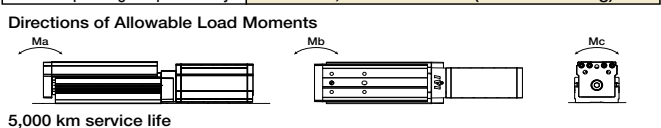

Dimensions

CAD drawings can be downloaded from IAI website. [www.intelligentactuator.com](http://www.intelligentactuator.com)

For Special Orders P. A-9



\* Please note that, for 25mm stroke model with brake, the motor unit protrudes from the end of the table.

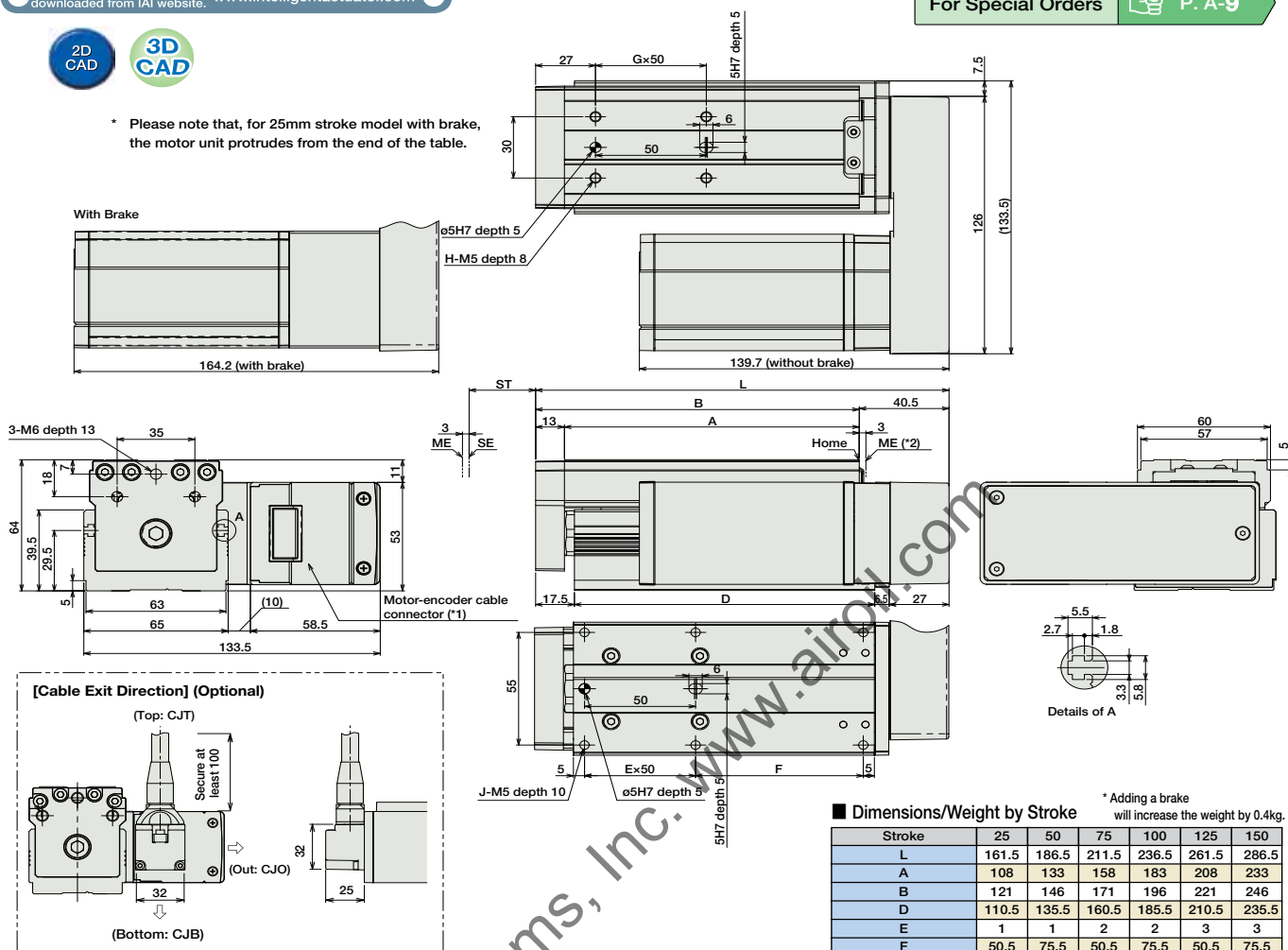

■ Dimensions/Weight by Stroke \* Adding a brake will increase the weight by 0.4kg.

Stroke	25	50	75	100	125	150
L	161.5	186.5	211.5	236.5	261.5	286.5
A	108	133	158	183	208	233
B	121	146	171	196	221	246
D	110.5	135.5	160.5	185.5	210.5	235.5
E	1	1	2	2	3	3
F	50.5	75.5	50.5	75.5	50.5	75.5
G	1	1	2	2	3	3
H	4	4	6	6	8	8
J	6	6	8	8	10	10
Weight (kg)	2.1	2.3	2.5	2.7	2.9	3.1

(\*1) The motor-encoder cable is provided as an integrated cable. (see page A-39)  
 (\*2) After homing, the slider moves to the ME; therefore, please watch for any interference with the surrounding objects.  
 ME: Mechanical end SE: Stroke end

② Compatible Controllers

The RCP3 series actuators can operate with the controllers below. Select the controller according to your usage.

Name	External View	Model	Description	Max. Positioning Points	Input Voltage	Power Supply Capacity	Standard Price	See Page
Solenoid Valve Type		PMEC-C-42PI-NP-2-①	Easy-to-use controller, even for beginners	3 points	AC100V AC200V	See P481		→ P477
	Splash-Proof Solenoid Valve Type		PSEP-C-42PI-NP-2-0					
Positioner Type			PCON-C-42PI-NP-2-0	Positioning is possible for up to 512 points	512 points	DC24V	2A max.	
	Safety-Compliant Positioner Type		PCON-CG-42PI-NP-2-0					
Pulse Train Input Type (Differential Line Driver)		PCON-PL-42PI-NP-2-0	Pulse train input type with different line driver support	(-)				
Pulse Train Input Type (Open Collector)		PCON-PO-42PI-NP-2-0	Pulse train input type with open collector support					
Serial Communication Type		PCON-SE-42PI-N-0-0	Dedicated to serial communication	64 points				
Field Network Type		RPCON-42P	Dedicated to field network	768 points				→ P503
Program Control Type		PSEL-C-1-42PI-NP-2-0	Programmed operation is possible. Operation is possible on up to 2 axes	1500 points				→ P557

\* This is for the single-axis PSEL.  
 \* ① is a placeholder for the power supply voltage (1: 100V, 2: 100~240V).

- Slider Type
- Mini
- Standard
- Controllers Integrated
- Rod Type
- Mini
- Standard
- Controllers Integrated
- Table/Arm/Flat Type
- Mini
- Standard
- Gripper/Rotary Type
- Linear Servo Type
- Cleanroom Type
- Splash Proof
- Controllers
- PMEC/AMEC
- PSEP/ASEP
- ROBO NET
- ERC2
- PCON
- ACON
- SCON
- PSEL
- ASEL
- SSEL
- XSEL
- Pulse Motor
- Servo Motor (24V)
- Servo Motor (200V)
- Linear Servo Motor

# RCP3-TA7R

ROBO Cylinder Table Type Side-Mounted Motor 75mm Width Pulse Motor Ball Screw

■ Configuration: **RCP3** — **TA7R** — **I** — **42P** —  —  —  —  —

Series — Type — Encoder — Motor — Lead — Stroke — Compatible Controllers — Cable Length — Option

I: Incremental  
\* The simple absolute encoder is also considered type "I".

42P: Pulse motor  
42  size

12 : 12mm  
6 : 6mm  
3 : 3mm

25: 25mm  
↓  
200: 200mm (25mm pitch increments)

P1: PCON  
RCON  
PSEL  
P3: PMEC  
PSEP

N : None  
P : 1m  
S : 3m  
M : 5m  
X  : Custom

See Options below  
\* Be sure to specify which side the motor is to be mounted (ML/MR).

\* See page Pre-35 for an explanation of the naming convention.



Technical References P. A-5



- (1) Since the RCP3 series use a pulse motor, the load capacity decreases at high speeds. Check in the Speed vs. Load Capacity graph below to see if your desired speed and load capacity are supported.
- (2) Please note that the maximum speed is different when used horizontally versus vertically.
- (3) The load capacity is based on operation at an acceleration of 0.3G (0.2G for the 3mm-lead model, or when used vertically). This is the upper limit of the acceleration.

■ Speed vs. Load Capacity  
Due to the characteristics of the Pulse motor, the RCP3 series' load capacity decreases at high speeds. In the table below, check if your desired speed and load capacity are supported.

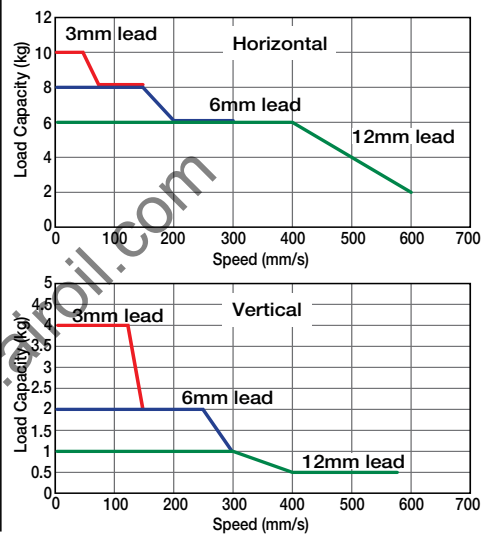

Actuator Specifications				
■ Lead and Load Capacity				
Model	Lead (mm)	Max. Load Capacity		Maximum Push Force (N)
		Horizontal (kg)	Vertical (kg)	
RCP3-TA7R-I-42P-12-①-②-③-④	12	~ 6	~ 1	47
RCP3-TA7R-I-42P-6-①-②-③-④	6	~ 8	~ 2	95
RCP3-TA7R-I-42P-3-①-②-③-④	3	~ 10	~ 4	189

Legend ① Stroke ② Compatible controller ③ Cable length ④ Options

■ Stroke and Maximum Speed	
Stroke / Lead	25 ~ 200 (25mm increments)
12	600 <580>
6	300
3	150

\* The values enclosed in "<" ">" apply to vertical usage. (Unit: mm/s)

① Stroke List

Stroke (mm)	Standard Price
25	-
50	-
75	-
100	-
125	-
150	-
175	-
200	-

③ Cable List

Type	Cable Symbol	Standard Price
Standard (Robot Cables)	P (1m)	-
	S (3m)	-
	M (5m)	-
Special Lengths	X06 (6m) ~ X10 (10m)	-
	X11 (11m) ~ X15 (15m)	-
	X16 (16m) ~ X20 (20m)	-

\* The standard cable is the motor-encoder integrated robot cable.  
\* See page A-39 for cables for maintenance.

④ Option List

Name	Option Code	See Page	Standard Price
Brake	B	→ A-25	-
Cable exit direction (Top)	CJT		
Cable exit direction (Outside)	CJO	→ A-25	-
Cable exit direction (Bottom)	CJB		
Left-Mounted Motor (Standard)	ML	→ A-33	-
Right-Mounted Motor	MR	→ A-33	-
Reversed-home	NM	→ A-33	-

Actuator Specifications

Item	Description
Drive System	Ball screw $\phi$ 10mm C10 grade
Positioning Repeatability	$\pm$ 0.02mm
Lost Motion	0.1mm or less
Base	Material: Material: Aluminum (special alumite treated)
Allowable Static Load Moment	Ma: 42.6 N·m Mb: 60.8 N·m Mc: 123.2 N·m
Allowable Dynamic Load Moment	Ma: 9.91 N·m Mb: 14.13 N·m Mc: 28.65 N·m
Overhang Load Length	Within the load moment range
Ambient Operating Temp./Humidity	0~40°C, 85% RH or less (non-condensing)

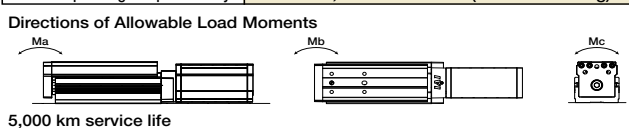

Dimensions

CAD drawings can be downloaded from IAI website. [www.intelligentactuator.com](http://www.intelligentactuator.com)

For Special Orders P. A-9



\* Please note that, for 25mm stroke model with brake, the motor unit protrudes from the end of the table.

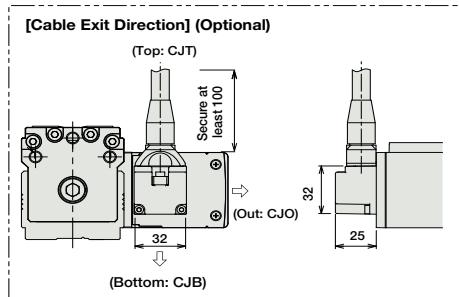
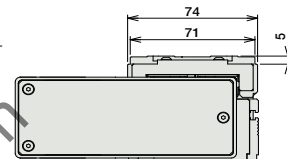
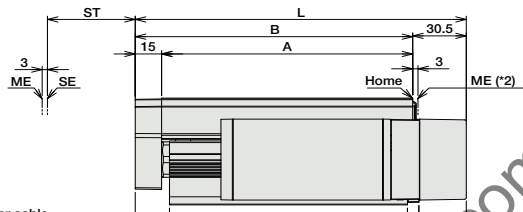
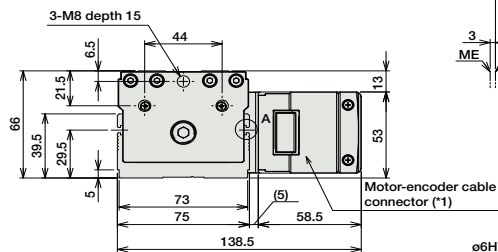
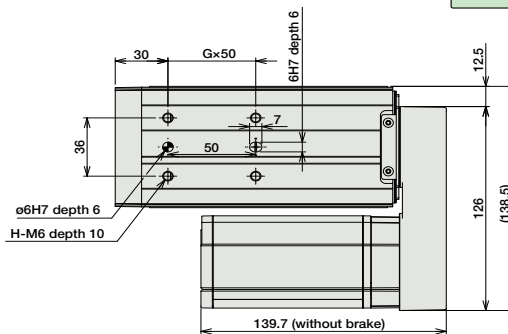
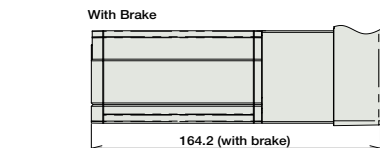

**■ Dimensions/Weight by Stroke** \* Adding a brake will increase the weight by 0.4kg.

Stroke	25	50	75	100	125	150	175	200
L	163.5	188.5	213.5	238.5	263.5	288.5	313.5	338.5
A	118	143	168	193	218	243	268	293
B	133	158	183	208	233	258	283	308
D	110.5	135.5	160.5	185.5	210.5	235.5	260.5	285.5
E	1	1	2	2	3	3	4	4
F	50.5	75.5	50.5	75.5	50.5	75.5	50.5	75.5
G	1	1	2	2	3	3	4	4
H	4	4	6	6	8	8	10	10
J	6	6	8	8	10	10	12	12
Weight (kg)	2.4	2.6	2.8	3.1	3.3	3.5	3.7	3.9

(\*1) The motor-encoder cable is provided as an integrated cable. (see page A-39)  
 (\*2) After homing, the slider moves to the ME; therefore, please watch for any interference with the surrounding objects.  
 ME: Mechanical end  
 SE: Stroke end

② Compatible Controllers

The RCP3 series actuators can operate with the controllers below. Select the controller according to your usage.

Name	External View	Model	Description	Max. Positioning Points	Input Voltage	Power Supply Capacity	Standard Price	See Page
Solenoid Valve Type		PMEC-C-42PI-NP-2-①	Easy-to-use controller, even for beginners	3 points	AC100V AC200V	See P481	-	→ P477
Splash-Proof Solenoid Valve Type		PSEP-C-42PI-NP-2-0	Operable with same signal as solenoid valve. Supports both single and double solenoid types. No homing necessary with simple absolute type.					
Positioner Type		PCON-C-42PI-NP-2-0	Positioning is possible for up to 512 points	512 points	DC24V	2A max.	-	→ P525
Safety-Compliant Positioner Type		PCON-CG-42PI-NP-2-0						
Pulse Train Input Type (Differential Line Driver)		PCON-PL-42PI-NP-2-0	Pulse train input type with differential line driver support	(-)	DC24V	2A max.	-	→ P525
Pulse Train Input Type (Open Collector)		PCON-PO-42PI-NP-2-0	Pulse train input type with open collector support					
Serial Communication Type		PCON-SE-42PI-N-0-0	Dedicated to serial communication	64 points	DC24V	2A max.	-	→ P503
Field Network Type		RPCON-42P	Dedicated to field network	768 points				
Program Control Type		PSEL-C-1-42PI-NP-2-0	Programmed operation is possible. Operation is possible on up to 2 axes	1500 points	DC24V	2A max.	-	→ P557

\* This is for the single-axis PSEL.  
 \* ① is a placeholder for the power supply voltage (1: 100V, 2: 100~240V).

# RCA2-TCA3N

ROBO Cylinder Mini Table Type Short-Length Compact Model 32mm Width  
24V Servo Motor Lead Screw

■ Configuration: **RCA2** — **TCA3N** — **I** — **10** — **30** — **A1** — **N** — **K2**

Series — Type — Encoder — Motor — Lead — Stroke — Compatible Controllers — Cable Length — Option

I: Incremental  
\* The simple absolute encoder is also considered type "I".

10: 10W Servo motor

4S: 4mm lead screw  
2S: 2mm lead screw  
1S: 1mm lead screw

30: 30mm

A1: ACON  
RACON  
ASEL  
A3: AMEC  
ASEP

N: None  
P: 1m  
S: 3m  
M: 5m  
X  : Custom

K2: Connector cable exit direction  
LA: Power-saving

\* See page Pre-35 for an explanation of the naming convention.

Power-saving

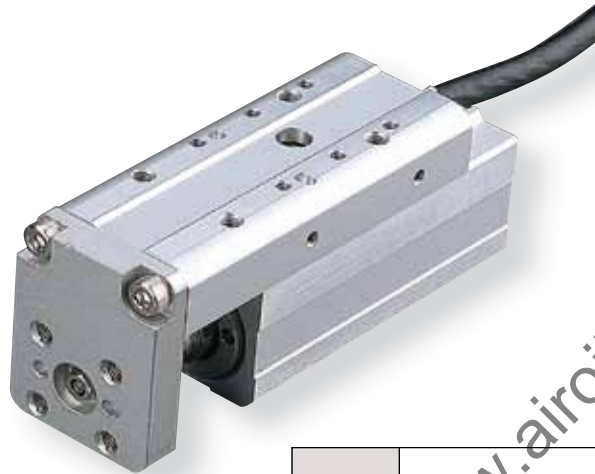

Technical References P. A-5

**POINT**  
Notes on Selection

- (1) The load capacity is based on operation at an acceleration of 0.2G. This is the upper limit of the acceleration.
- (2) This model uses a Lead screw, therefore please ensure that your usage is appropriate for its characteristics. (See page Pre-42 for more information.)

### Actuator Specifications

#### ■ Lead and Load Capacity

Model	Motor Output (W)	Feed Screw	Lead (mm)	Max. Load Capacity		Rated Thrust (N)	Positioning Repeatability (mm)	Stroke (mm)
				Horizontal (kg)	Vertical (kg)			
RCA2-TCA3N-I-10-4S-30-①-②-③	10	Lead screw	4	0.25	0.125	25.1	±0.05	30 (Fixed)
RCA2-TCA3N-I-10-2S-30-①-②-③			2	0.5	0.25	50.3		
RCA2-TCA3N-I-10-1S-30-①-②-③			1	1	0.5	100.5		

Legend ① Compatible controller ② Cable length ③ Options

#### ■ Stroke and Maximum Speed

Lead	Stroke (mm)	
	4	30
Lead screw	4	200
	2	100
	1	50

(Unit: mm/s)

#### Stroke List

Stroke (mm)	Standard Price
30	-

#### ② Cable List

Type	Cable Symbol	Standard Price
Standard (Robot Cables)	P (1m)	-
	S (3m)	-
	M (5m)	-
Special Lengths	X06 (6m) ~ X10 (10m)	-
	X11 (11m) ~ X15 (15m)	-
	X16 (16m) ~ X20 (20m)	-
		-

\* The RCA2 comes standard with a robot cable.

\* See page A-39 for cables for maintenance.

#### ③ Option List

Name	Option Code	See Page	Standard Price
Connector cable exit direction	K2	→ A-32	-
Power-saving	LA	→ A-32	-

#### Actuator Specifications

Item	Description
Drive System	Lead screw ø4mm C10 grade
Lost Motion	0.3mm or less (initial value)
Frame	Material: Aluminum (white alumite treated)
Allowable Dynamic Moment (Note)	Ma: 9.9 N·m Mb: 9.9 N·m Mc: 3.3 N·m
Ambient Operating Temp./Humidity	0~40°C, 85% RH or less (non-condensing)
Service Life	Horizontal: 10 million cycles Vertical: 5 million cycles

(Note) Based on a 5,000 km service life set for the guide.

Dimensions

CAD drawings can be downloaded from IAI website. [www.intelligentactuator.com](http://www.intelligentactuator.com)

For Special Orders P. A-9



- \*1 The motor-encoder cable is connected here. See page A-39 for details on cables.
- \*2 When homing, the table moves to the mechanical end; therefore, please watch for any interference with the surrounding objects.

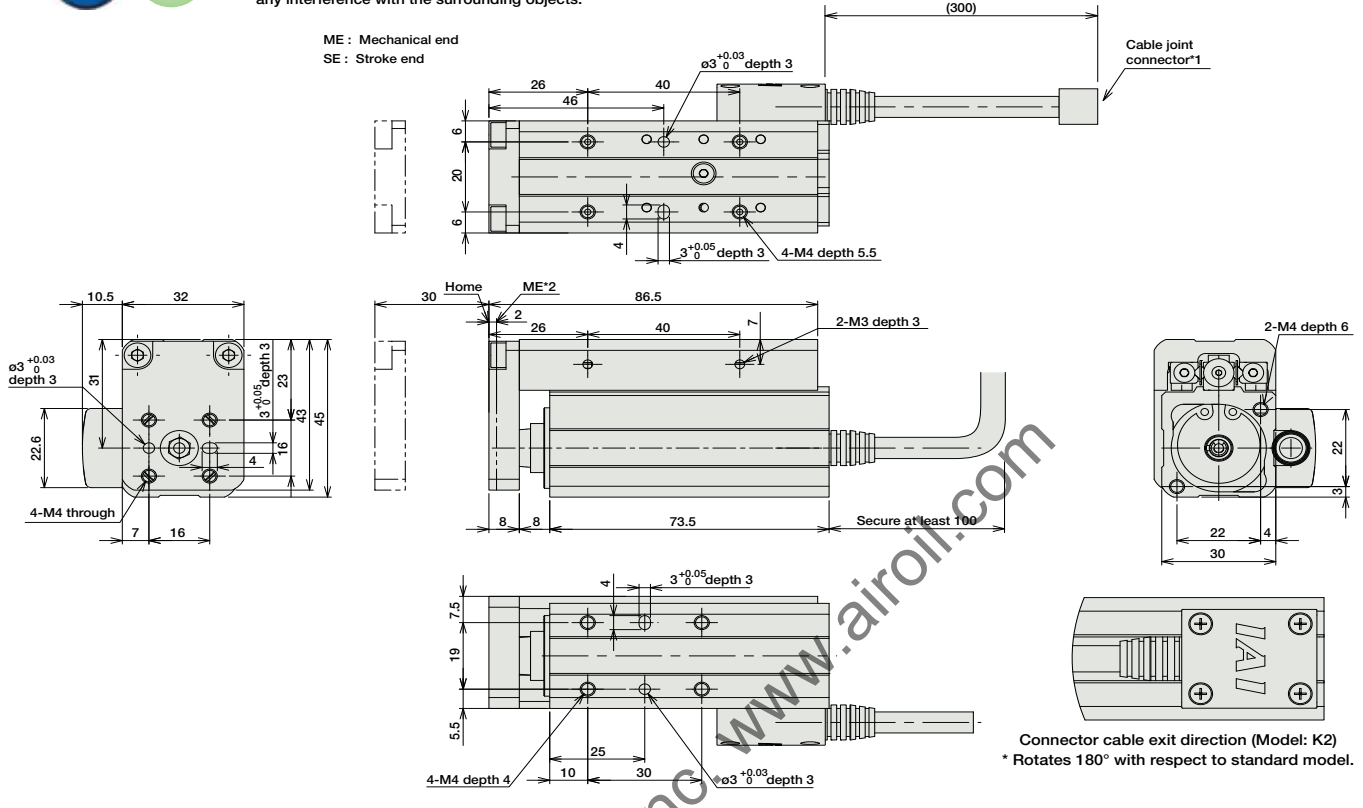

■ Dimensions/Weight by Stroke

Stroke	30
Weight (kg)	0.37

① Compatible Controllers

The RCA2 series actuators can operate with the controllers below. Select the controller according to your usage.

Name	External View	Model	Description	Max. Positioning Points	Input Voltage	Power Supply Capacity	Standard Price	See Page
Solenoid Valve Type		AMEC-C-10①-NP-2-1	Easy-to-use controller, even for beginners	3 points	AC100V	2.4A rated	-	→ P477
Splash-Proof Solenoid Valve Type		ASEP-C-10①-NP-2-0	Operable with same signal as solenoid valve. Supports both single and double solenoid types. No homing necessary with simple absolute type.				-	→ P487
Positioner Type		ACON-C-10①-NP-2-0	Positioning is possible for up to 512 points	512 points	DC24V	(Standard) 1.3A rated 4.4A max.	-	
Safety-Compliant Positioner Type		ACON-CG-10①-NP-2-0					-	
Pulse Train Input Type (Differential Line Driver)		ACON-PL-10①-NP-2-0	Pulse train input type with differential line driver support	(-)	DC24V	(Power-saving) 1.3A rated 2.5A max.	-	→ P535
Pulse Train Input Type (Open Collector)		ACON-PO-10①-NP-2-0	Pulse train input type with open collector support				-	
Serial Communication Type		ACON-SE-10①-N-0-0	Dedicated to serial communication	64 points			-	
Field Network Type		RACON-10①	Dedicated to field network	768 points			-	→ P503
Program Control Type		ASEL-C-1-10①-NP-2-0	Programmed operation is possible Operation is possible on up to 2 axes	1500 points			-	→ P567

\* This is for the single-axis ASEL.  
 \* ① is a placeholder for the code "LA" if the power-saving option is specified.

- Slider Type
- Mini
- Standard
- Controllers Integrated
- Rod Type
- Mini
- Standard
- Controllers Integrated
- Table/Arm/Flat Type
- Mini
- Standard
- Gripper/Rotary Type
- Linear Servo Type
- Cleanroom Type
- Splash Proof
- Controllers
- PMEC/AMEC
- PSEP/ASEP
- ROBO NET
- ERC2
- PCON
- ACON
- SCON
- PSEL
- ASEL
- SSEL
- XSEL
- Pulse Motor
- Servo Motor (24V)
- Servo Motor (200V)
- Linear Servo Motor



# RCA2-TCA4N

ROBO Cylinder Mini Table Type Short-Length Compact Model 36mm Width  
24V Servo Motor Ball Screw/Lead Screw Models

■ Configuration: **RCA2** — **TCA4N** — **I** — **20** — **30** — **30** — **30** — **30** — **30**

Series — Type — Encoder — Motor — Lead — Stroke — Compatible Controllers — Cable Length — Option

I: Incremental  
\* The simple absolute encoder is also considered type "I".

20: 20W Servo motor

6: 6mm ball screw  
4: 4mm ball screw  
2: 2mm ball screw  
6S: 6mm lead screw  
4S: 4mm lead screw  
2S: 2mm lead screw

A1: ACON  
RACON  
ASEL  
A3: AMEC  
ASEP

N: None  
P: 1m  
S: 3m  
M: 5m  
X   : Custom

K2: Connector cable exit direction  
LA: Power-saving

\* See page Pre-35 for an explanation of the naming convention.

Power-saving

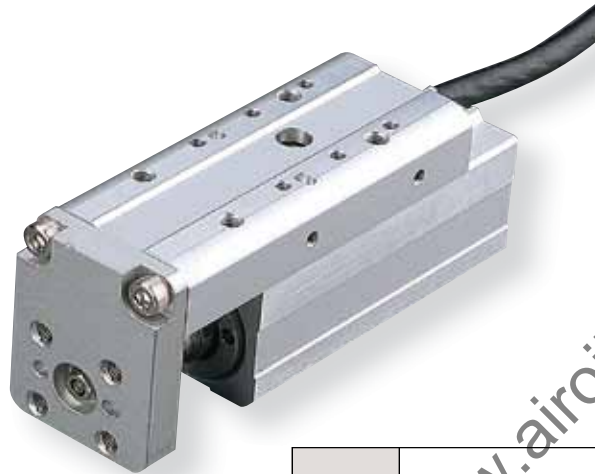

Technical References P. A-5

**POINT**  
Notes on Selection

(1) The load capacity is based on operation at an acceleration of 0.3G (0.2G for the 2mm-lead model, or when used vertically). This is the upper limit of the acceleration.

(2) When using the Lead screw model, please ensure that your usage is appropriate for its characteristics. (See page Pre-42 for more information.)

## Actuator Specifications

### Lead and Load Capacity

Model	Motor Output (W)	Feed Screw	Lead (mm)	Max. Load Capacity		Rated Thrust (N)	Positioning Repeatability (mm)	Stroke (mm)
				Horizontal (kg)	Vertical (kg)			
RCA2-TCA4N-I-20-6-30-①-②-③	20	Ball screw	6	2	0.5	33.8	±0.02	30 (Fixed)
RCA2-TCA4N-I-20-4-30-①-②-③			4	3	0.75	50.7		
RCA2-TCA4N-I-20-2-30-①-②-③			2	6	1.5	101.5		
RCA2-TCA4N-I-20-6S-30-①-②-③	20	Lead screw	6	0.25	0.125	19.9	±0.05	30 (Fixed)
RCA2-TCA4N-I-20-4S-30-①-②-③			4	0.5	0.25	29.8		
RCA2-TCA4N-I-20-2S-30-①-②-③			2	1	0.5	59.7		

Legend ① Compatible controller ② Cable length ③ Options

### Stroke and Maximum Speed

Lead	Stroke (mm)	
	6	30
Ball screw	6	270 <220>
	4	200
	2	100
Lead screw	6	220
	4	200
	2	100

\* The values enclosed in "<" ">" apply to vertical usage. (Unit: mm/s)

### Stroke List

Stroke (mm)	Standard Price	
	Feed Screw	
	Ball Screw Model	Lead Screw Model
30	-	-

### ② Cable List

Type	Cable Symbol	Standard Price
Standard (Robot Cables)	P (1m)	-
	S (3m)	-
	M (5m)	-
Special Lengths	X06 (6m) ~ X10 (10m)	-
	X11 (11m) ~ X15 (15m)	-
	X16 (16m) ~ X20 (20m)	-
	-	-

\* The RCA2 comes standard with a robot cable.

\* See page A-39 for cables for maintenance.

### ③ Option List

Name	Option Code	See Page	Standard Price
Connector cable exit direction	K2	→ A-32	-
Power-saving	LA	→ A-32	-

### Actuator Specifications

Item	Description
Drive System	Ball screw/Lead screw ø6mm C10 grade
Lost Motion	Ball screw: 0.1mm or less/Lead screw: 0.3mm or less (initial value)
Frame	Material: Aluminum (white alumite treated)
Allowable Dynamic Moment (Note)	Ma: 9.9 N·m Mb: 9.9 N·m Mc: 3.3 N·m
Ambient Operating Temp./Humidity	0~40°C, 85% RH or less (non-condensing)
Service Life   Lead Screw Model	Horizontal: 10 million cycles Vertical: 5 million cycles

(Note) Based on a 5,000 km service life set for the guide.

Dimensions

CAD drawings can be downloaded from IAI website. [www.intelligentactuator.com](http://www.intelligentactuator.com)



- \*1 The motor-encoder cable is connected here. See page A-39 for details on cables.
- \*2 When homing, the table moves to the mechanical end; therefore, please watch for any interference with the surrounding objects.

For Special Orders P. A-9

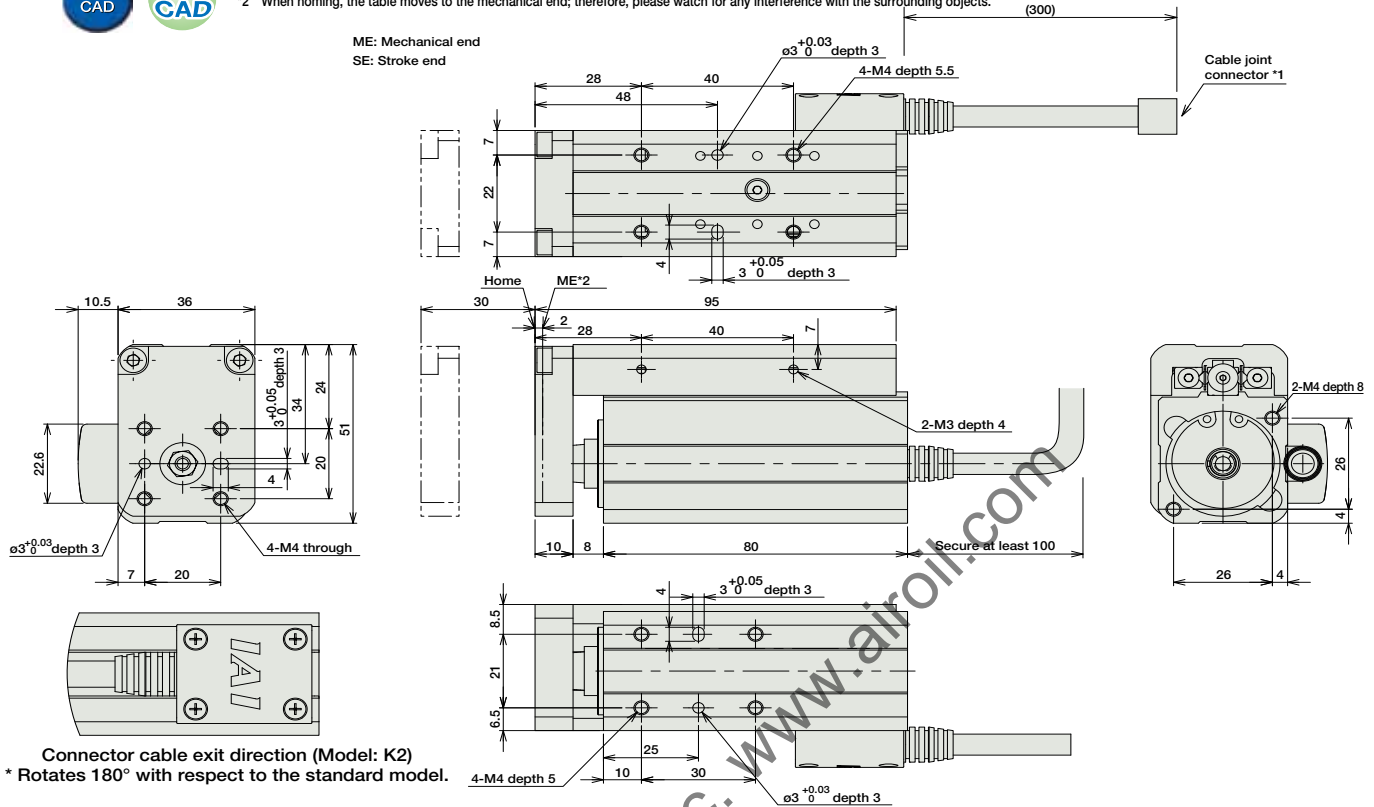

■ Dimensions/Weight by Stroke

Stroke	30
Weight (kg)	0.48

① Compatible Controllers

The RCA2 series actuators can operate with the controllers below. Select the controller according to your usage.

Name	External View	Model	Description	Max. Positioning Points	Input Voltage	Power Supply Capacity	Standard Price	See Page
Solenoid Valve Type		AMEC-C-20①-NP-2-1	Easy-to-use controller, even for beginners	3 points	DC24V	(Standard) 1.3A rated 4.4A max.  (Power-saving) 1.3A rated 2.5A max.	-	→ P477
		ASEP-C-20①-NP-2-0	Operable with same signal as solenoid valve. Supports both single and double solenoid types. No homing necessary with simple absolute type.				-	→ P487
Positioner Type		ASEP-CW-20①-NP-2-0		Positioning is possible for up to 512 points			-	→ P535
		ACON-C-20①-NP-2-0	-					
Safety-Compliant Positioner Type		ACON-CG-20①-NP-2-0	512 points	-				
Pulse Train Input Type (Differential Line Driver)		ACON-PL-20①-NP-2-0	Pulse train input type with differential line driver support	(-)			-	
Pulse Train Input Type (Open Collector)		ACON-PO-20①-NP-2-0	Pulse train input type with open collector support				-	
Serial Communication Type		ACON-SE-20①-N-0-0	Dedicated to serial communication	64 points			-	
Field Network Type		RAON-20①	Dedicated to field network	768 points			-	
Program Control Type		ASEL-C-1-20①-NP-2-0	Programmed operation is possible Operation is possible on up to 2 axes	1500 points	-	→ P567		

\* This is for the single-axis ASEL.  
\* ① is a placeholder for the code "LA" if the power-saving option is specified.

- Slider Type
- Mini
- Standard
- Controllers Integrated
- Rod Type
- Mini
- Standard
- Controllers Integrated
- Table/Arm/Flat Type
- Mini
- Standard
- Gripper/Rotary Type
- Linear Servo Type
- Cleanroom Type
- Splash Proof
- Controllers
- PMEC/AMEC
- PSEP/ASEP
- ROBO NET
- ERC2
- PCON
- ACON
- SCON
- PSEL
- ASEL
- SSEL
- XSEL
- Pulse Motor
- Servo Motor (24V)
- Servo Motor (200V)
- Linear Servo Motor

# RCA2-TWA3N

ROBO Cylinder Mini Table Type Short-Length Wide Model 50mm Width  
24V Servo Motor Lead Screw Model

■ Configuration: **RCA2** — **TWA3N** — **I** — **10** — **30** — **A1** — **N** — **K2**

Series	Type	Encoder	Motor	Lead	Stroke	Compatible Controllers	Cable Length	Option
		I: Incremental * The simple absolute encoder is also considered type "I".	10: 10W Servo motor	4S: 4mm lead screw 2S: 2mm lead screw 1S: 1mm lead screw	30: 30mm	A1: ACON RACON ASEL A3: AMEC ASEP	N: None P: 1m S: 3m M: 5m X □ □: Custom	K2: Connector cable exit direction LA: Power-saving

\* See page Pre-35 for an explanation of the naming convention.



Power-saving

Technical References P. A-5

**POINT**  
Notes on Selection

- (1) The load capacity is based on operation at an acceleration of 0.2G. This is the upper limit of the acceleration.
- (2) This model uses a Lead screw, therefore please ensure that your usage is appropriate for its characteristics. (See page Pre-42 for more information.)

## Actuator Specifications

### Lead and Load Capacity

Model	Motor Output (W)	Feed Screw	Lead (mm)	Max. Load Capacity		Rated Thrust (N)	Positioning Repeatability (mm)	Stroke (mm)
				Horizontal (kg)	Vertical (kg)			
RCA2-TWA3N-I-10-4S-30-①-②-③	10	Lead screw	4	0.25	0.125	25.1	±0.05	30 (Fixed)
RCA2-TWA3N-I-10-2S-30-①-②-③			2	0.5	0.25	50.3		
RCA2-TWA3N-I-10-1S-30-①-②-③			1	1	0.5	100.5		

Legend ① Compatible controller ② Cable length ③ Options

### Stroke and Maximum Speed

Lead	Stroke	
	4 (mm)	30 (mm)
Lead screw	4	200
	2	100
	1	50

(Unit: mm/s)

### Stroke List

Stroke (mm)	Standard Price
30	-

### ② Cable List

Type	Cable Symbol	Standard Price
Standard (Robot Cables)	P (1m)	-
	S (3m)	-
	M (5m)	-
Special Lengths	X06 (6m) ~ X10 (10m)	-
	X11 (11m) ~ X15 (15m)	-
	X16 (16m) ~ X20 (20m)	-
		-

\* The RCA2 comes standard with a robot cable.

\* See page A-39 for cables for maintenance.

### ③ Option List

Name	Option Code	See Page	Standard Price
Connector cable exit direction	K2	→ A-32	-
Power-saving	LA	→ A-32	-

### Actuator Specifications

Item	Description
Drive System	Lead screw ø4mm C10 grade
Lost Motion	0.3mm or less (initial value)
Frame	Material: Aluminum (white alumite treated)
Allowable Dynamic Moment (Note)	Ma: 9.9 N·m Mb: 9.9 N·m Mc: 9.4 N·m
Ambient Operating Temp./Humidity	0~40°C, 85% RH or less (non-condensing)
Service Life	Horizontal: 10 million cycles Vertical: 5 million cycles

(Note) Based on a 5,000 km service life set for the guide.

Dimensions

CAD drawings can be downloaded from IAI website. [www.intelligentactuator.com](http://www.intelligentactuator.com)

For Special Orders P. A-9



- \*1 The motor-encoder cable is connected here. See page A-39 for details on cables.
- \*2 When homing, the table moves to the mechanical end; therefore, please watch for any interference with the surrounding objects.

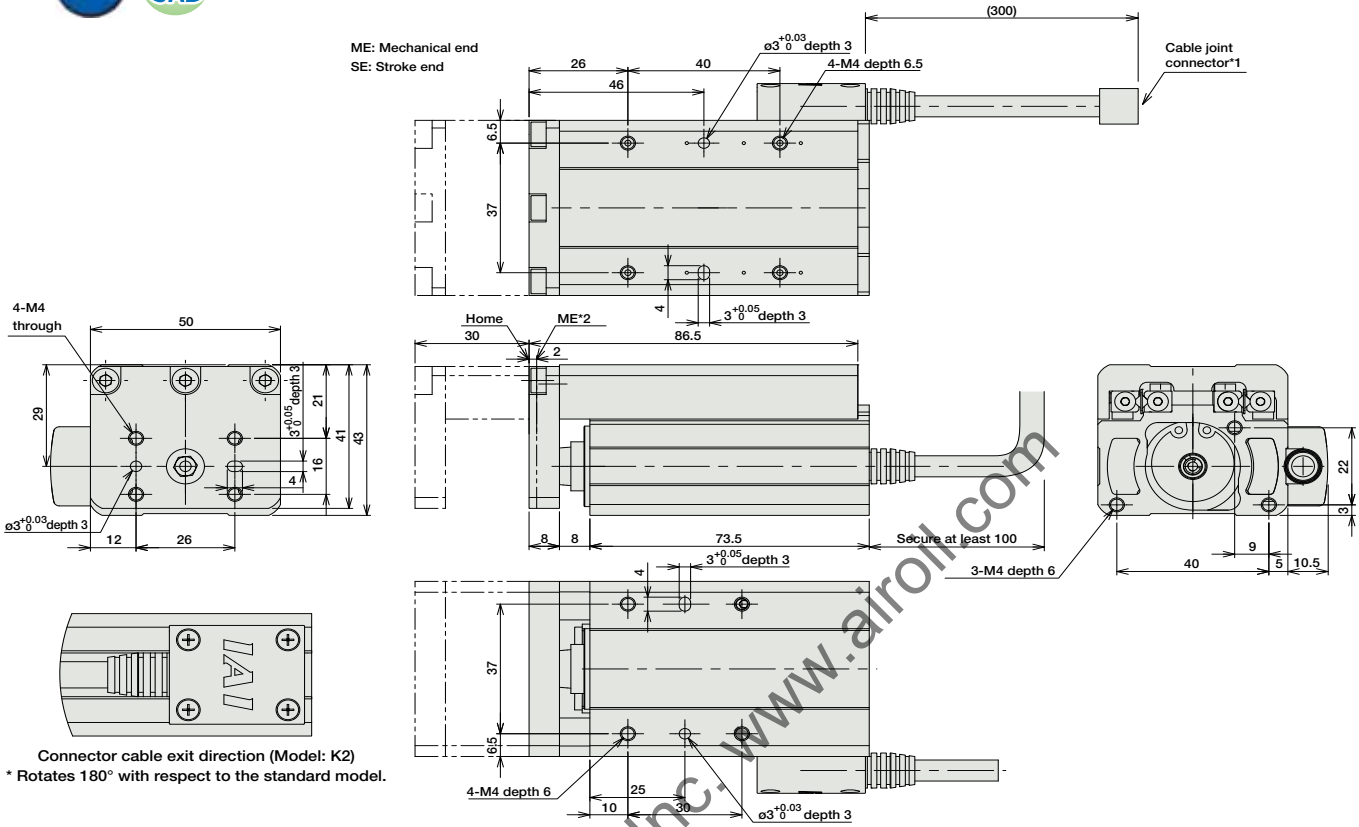

■ Dimensions/Weight by Stroke

Stroke	30
Weight (kg)	0.52

① Compatible Controllers

The RCA2 series actuators can operate with the controllers below. Select the controller according to your usage.

Name	External View	Model	Description	Max. Positioning Points	Input Voltage	Power Supply Capacity	Standard Price	See Page
Solenoid Valve Type		AMEC-C-10①-NP-2-1	Easy-to-use controller, even for beginners	3 points	AC100V	2.4A rated	-	→ P477
Splash-Proof Solenoid Valve Type		ASEP-C-10①-NP-2-0	Operable with same signal as solenoid valve. Supports both single and double solenoid types. No homing necessary with simple absolute type.				-	→ P487
Positioner Type		ACON-C-10①-NP-2-0	Positioning is possible for up to 512 points	512 points	DC24V	(Standard) 1.3A rated 4.4A max.	-	→ P535
Safety-Compliant Positioner Type		ACON-CG-10①-NP-2-0					-	
Pulse Train Input Type (Differential Line Driver)		ACON-PL-10①-NP-2-0	Pulse train input type with differential line driver support	(-)	DC24V	(Power-saving) 1.3A rated 2.5A max.	-	→ P503
Pulse Train Input Type (Open Collector)		ACON-PO-10①-NP-2-0	Pulse train input type with open collector support				-	
Serial Communication Type		ACON-SE-10①-N-0-0	Dedicated to serial communication	64 points	-	-	-	-
Field Network Type		RACON-10①	Dedicated to field network	768 points	-	-	-	→ P503
Program Control Type		ASEL-C-1-10①-NP-2-0	Programmed operation is possible Operation is possible on up to 2 axes	1500 points	-	-	-	→ P567

\* This is for the single-axis ASEL.  
\* ① is a placeholder for the code "LA" if the power-saving option is specified.

- Slider Type
- Mini
- Standard
- Controllers Integrated
- Rod Type
- Mini
- Standard
- Controllers Integrated
- Table/Arm /Flat Type
- Mini
- Standard
- Gripper/ Rotary Type
- Linear Servo Type
- Cleanroom Type
- Splash Proof
- Controllers
- PMEC /AMEC
- PSEP /ASEP
- ROBO NET
- ERC2
- PCON
- ACON
- SCON
- PSEL
- ASEL
- SSEL
- XSEL
- Pulse Motor
- Servo Motor (24V)
- Servo Motor (200V)
- Linear Servo Motor

# RCA2-TWA4N

ROBO Cylinder Mini Table Type Short-Length Wide Model 58mm Width  
24V Servo Motor Ball Screw/Lead Screw Models

■ Configuration: **RCA2** — **TWA4N** — **I** — **20** — **30** — **30** — **30** — **30**

Series — Type — Encoder — Motor — Lead — Stroke — Compatible Controllers — Cable Length — Option

I: Incremental  
\* The simple absolute encoder is also considered type "I".

20: 20W Servo motor

6: 6mm ball screw  
4: 4mm ball screw  
2: 2mm ball screw  
6S: 6mm lead screw  
4S: 4mm lead screw  
2S: 2mm lead screw

30: 30mm

A1: ACON  
RACON  
ASEL  
A3: AMEC  
ASEP

N: None  
P: 1m  
S: 3m  
M: 5m  
X   : Custom

K2: Connector cable exit direction  
LA: Power-saving

\* See page Pre-35 for an explanation of the naming convention.

Power-saving



Technical References P. A-5

**POINT** Notes on Selection

(1) The load capacity is based on operation at an acceleration of 0.3G (0.2G for the 2mm-lead model, or when used vertically). This is the upper limit of the acceleration.

(2) When using the Lead screw model, please ensure that your usage is appropriate for its characteristics. (See Pre-42 for more information.)

## Actuator Specifications

### Lead and Load Capacity

Model	Motor Output (W)	Feed Screw	Lead (mm)	Max. Load Capacity		Rated Thrust (N)	Positioning Repeatability (mm)	Stroke (mm)
				Horizontal (kg)	Vertical (kg)			
RCA2-TWA4N-I-20-6-30-①-②-③	20	Ball screw	6	2	0.5	33.8	±0.02	30 (Fixed)
RCA2-TWA4N-I-20-4-30-①-②-③			4	3	0.75	50.7		
RCA2-TWA4N-I-20-2-30-①-②-③			2	6	1.5	101.5		
RCA2-TWA4N-I-20-6S-30-①-②-③	20	Lead screw	6	0.25	0.125	19.9	±0.05	30 (Fixed)
RCA2-TWA4N-I-20-4S-30-①-②-③			4	0.5	0.25	29.8		
RCA2-TWA4N-I-20-2S-30-①-②-③			2	1	0.5	59.7		

Legend ① Compatible controller ② Cable length ③ Options

### Stroke and Maximum Speed

Lead	Stroke (mm)	
	6	30
Ball screw	6	270 <220>
	4	200
	2	100
Lead screw	6	220
	4	200
	2	100

\* The values enclosed in "<" ">" apply to vertical usage. (Unit: mm/s)

### Stroke List

Stroke (mm)	Standard Price	
	Feed Screw	
	Ball Screw Model	Lead Screw Model
30	-	-

### Cable List

Type	Cable Symbol	Standard Price
Standard (Robot Cables)	P (1m)	-
	S (3m)	-
	M (5m)	-
Special Lengths	X06 (6m) ~ X10 (10m)	-
	X11 (11m) ~ X15 (15m)	-
	X16 (16m) ~ X20 (20m)	-
	-	-

\* The RCA2 comes standard with a robot cable.

\* See page A-39 for cables for maintenance.

### Option List

Name	Option Code	See Page	Standard Price
Connector cable exit direction	K2	→ A-32	-
Power-saving	LA	→ A-32	-

### Actuator Specifications

Item	Description
Drive System	Ball screw/Lead screw ø6mm C10 grade
Lost Motion	Ball screw: 0.1mm or less/Lead screw: 0.3mm or less (initial value)
Frame	Material: Aluminum (white alumite treated)
Allowable Dynamic Moment (Note)	Ma: 9.9 N-m Mb: 9.9 N-m Mc: 12.2 N-m
Ambient Operating Temp./Humidity	0~40°C, 85% RH or less (non-condensing)
Service Life   Lead Screw Model	Horizontal: 10 million cycles Vertical: 5 million cycles

(Note) Based on a 5,000 km service life set for the guide.

Dimensions

CAD drawings can be downloaded from IAI website. [www.intelligentactuator.com](http://www.intelligentactuator.com)

For Special Orders P. A-9



- \*1 The motor-encoder cable is connected here. See page A-39 for details on cables.
- \*2 When homing, the table moves to the mechanical end; therefore, please watch for any interference with the surrounding objects.

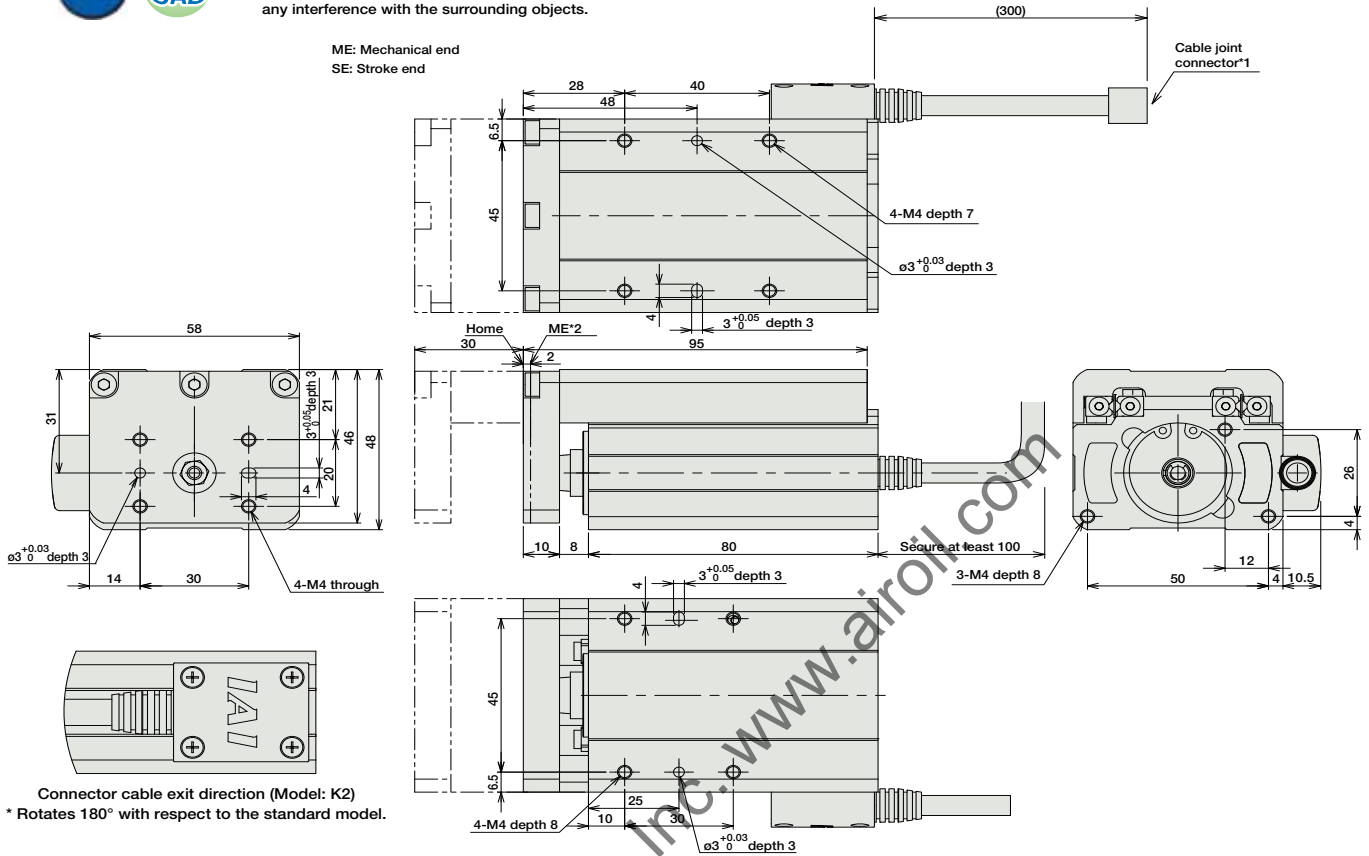

■ Dimensions/Weight by Stroke

Stroke	30
Weight (kg)	0.65

① Compatible Controllers

The RCA2 series actuators can operate with the controllers below. Select the controller according to your usage.

Name	External View	Model	Description	Max. Positioning Points	Input Voltage	Power Supply Capacity	Standard Price	See Page
Solenoid Valve Type		AMEC-C-20①-NP-2-1	Easy-to-use controller, even for beginners	3 points	AC100V	2.4A rated	-	→ P477
		ASEP-C-20①-NP-2-0	Operable with same signal as solenoid valve. Supports both single and double solenoid types. No homing necessary with simple absolute type.					
Splash-Proof Solenoid Valve Type		ASEP-CW-20①-NP-2-0						
Positioner Type		ACON-C-20①-NP-2-0	Positioning is possible for up to 512 points	512 points	DC24V	(Standard) 1.3A rated 4.4A max.  (Power-saving) 1.3A rated 2.5A max.	-	→ P535
Safety-Compliant Positioner Type		ACON-CG-20①-NP-2-0		-				
Pulse Train Input Type (Differential Line Driver)		ACON-PL-20①-NP-2-0	Pulse train input type with differential line driver support	(-)	DC24V	(Power-saving) 1.3A rated 2.5A max.	-	→ P535
Pulse Train Input Type (Open Collector)		ACON-PO-20①-NP-2-0	Pulse train input type with open collector support				-	
Serial Communication Type		ACON-SE-20①-N-0-0	Dedicated to serial communication	64 points			-	
Field Network Type		RACON-20①	Dedicated to field network	768 points			-	→ P503
Program Control Type		ASEL-C-1-20①-NP-2-0	Programmed operation is possible Operation is possible on up to 2 axes	1500 points			-	→ P567

\* This is for the single-axis ASEL.  
\* ① is a placeholder for the code "LA" if the power-saving option is specified.

- Slider Type
- Mini
- Standard
- Controllers Integrated
- Rod Type
- Mini
- Standard
- Controllers Integrated
- Table/Arm /Flat Type
- Mini
- Standard
- Gripper/ Rotary Type
- Linear Servo Type
- Cleanroom Type
- Splash Proof
- Controllers
- PMEC /AMEC
- PSEP /ASEP
- ROBO NET
- ERC2
- PCON
- ACON
- SCON
- PSEL
- ASEL
- SSEL
- XSEL
- Pulse Motor
- Servo Motor (24V)
- Servo Motor (200V)
- Linear Servo Motor

# RCA2-TFA3N

ROBO Cylinder Mini Table Type Short-Length Flat Model 61mm Width  
24V Servo Motor Lead Screw Model

■ Configuration: **RCA2** — **TFA3N** — **I** — **10** — **30** — **30** — **30** — **30**

Series — Type — Encoder — Motor — Lead — Stroke — Compatible Controllers — Cable Length — Option

I: Incremental  
\* The simple absolute encoder is also considered type "I".

10: 10W Servo motor

4S: 4mm lead screw  
2S: 2mm lead screw  
1S: 1mm lead screw

30: 30mm

A1: ACON  
RACON  
ASEL  
A3: AMEC  
ASEP

N: None  
P: 1m  
S: 3m  
M: 5m  
X  : Custom

K2: Connector cable exit direction  
LA: Power-saving

\* See page Pre-35 for an explanation of the naming convention.

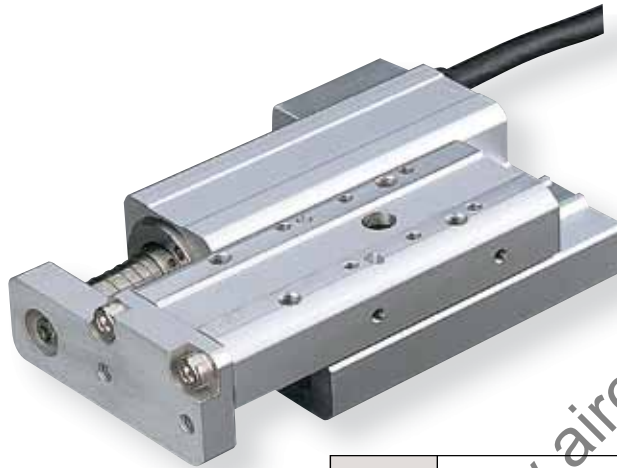

Power-saving

Technical References P. A-5

**POINT** Notes on Selection

- (1) The load capacity is based on operation at an acceleration of 0.2G. This is the upper limit of the acceleration.
- (2) This model uses a Lead screw, therefore please ensure that your usage is appropriate for its characteristics. (See page Pre-42 for more information.)

### Actuator Specifications

#### Lead and Load Capacity

Model	Motor Output (W)	Feed Screw	Lead (mm)	Max. Load Capacity		Rated Thrust (N)	Positioning Repeatability (mm)	Stroke (mm)
				Horizontal (kg)	Vertical (kg)			
RCA2-TFA3N-I-10-4S-30-①-②-③	10	Lead screw	4	0.25	0.125	25.1	±0.05	30 (Fixed)
RCA2-TFA3N-I-10-2S-30-①-②-③			2	0.5	0.25	50.3		
RCA2-TFA3N-I-10-1S-30-①-②-③			1	1	0.5	100.5		

Legend ① Compatible controller ② Cable length ③ Options

#### Stroke and Maximum Speed

Lead screw	Stroke (mm)	
	4	30
4	200	
2	100	
1	50	

(Unit: mm/s)

#### Stroke List

Stroke (mm)	Standard Price
30	-

#### ② Cable List

Type	Cable Symbol	Standard Price
Standard (Robot Cables)	P (1m)	-
	S (3m)	-
	M (5m)	-
Special Lengths	X06 (6m) ~ X10 (10m)	-
	X11 (11m) ~ X15 (15m)	-
	X16 (16m) ~ X20 (20m)	-
		-

\* The RCA2 comes standard with a robot cable.

\* See page A-39 for cables for maintenance.

#### ③ Option List

Name	Option Code	See Page	Standard Price
Connector cable exit direction	K2	→ A-32	-
Power-saving	LA	→ A-32	-

#### Actuator Specifications

Item	Description
Drive System	Lead screw ø4mm C10 grade
Lost Motion	0.3mm or less (initial value)
Frame	Material: Aluminum (white alumite treated)
Allowable Dynamic Moment (Note)	Ma: 9.9 N·m Mb: 9.9 N·m Mc: 3.3 N·m
Ambient Operating Temp./Humidity	0~40°C, 85% RH or less (non-condensing)
Service Life	Horizontal: 10 million cycles Vertical: 5 million cycles

(Note) Based on a 5,000 km service life set for the guide.

Dimensions

CAD drawings can be downloaded from IAI website. [www.intelligentactuator.com](http://www.intelligentactuator.com)



- \*1 The motor-encoder cable is connected here. See page A-39 for details on cables.
- \*2 When homing, the table moves to the mechanical end; therefore, please watch for any interference with the surrounding objects.

For Special Orders P. A-9

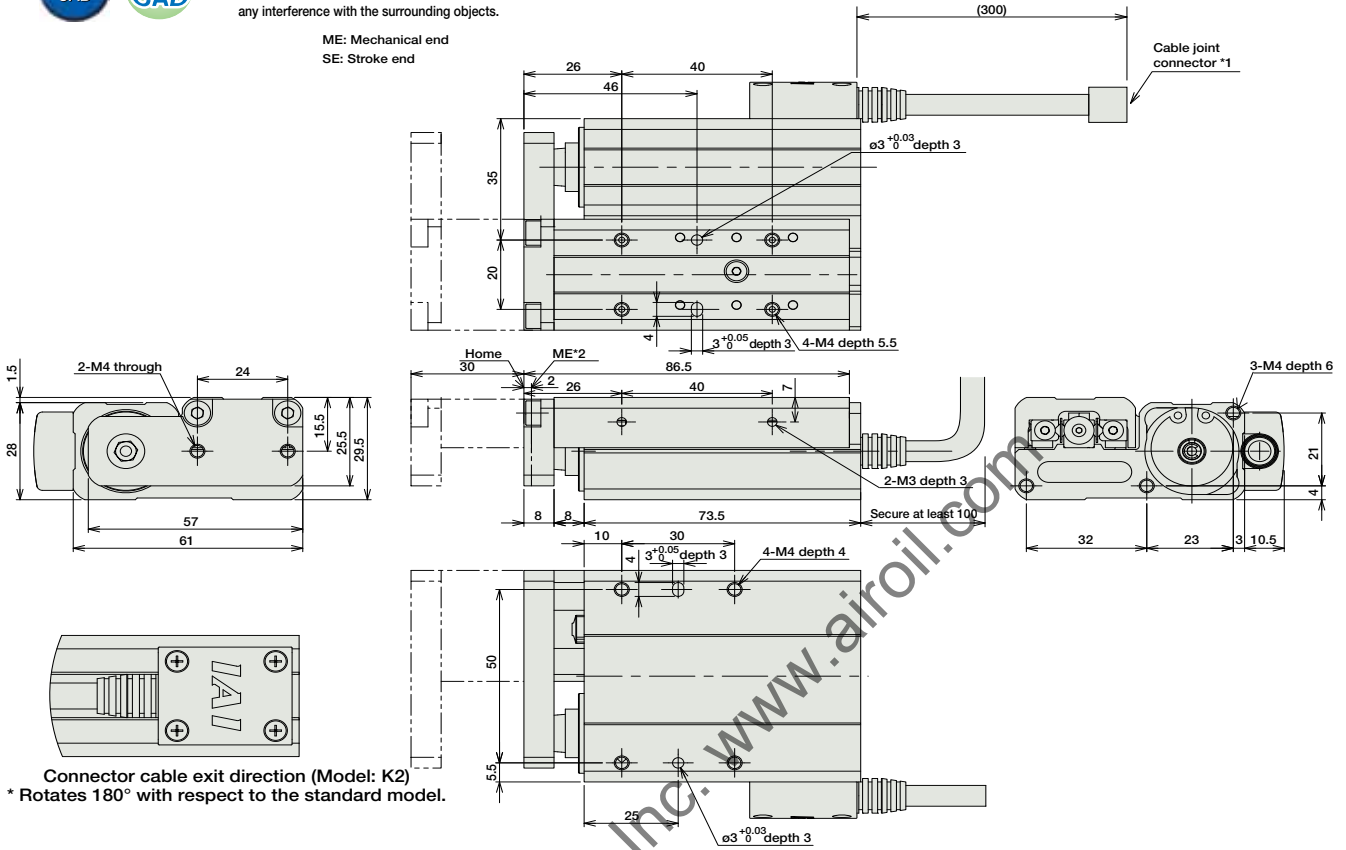

■ Dimensions/Weight by Stroke

Stroke	30
Weight (kg)	0.4

① Compatible Controllers

The RCA2 series actuators can operate with the controllers below. Select the controller according to your usage.

Name	External View	Model	Description	Max. Positioning Points	Input Voltage	Power Supply Capacity	Standard Price	See Page
Solenoid Valve Type		AMEC-C-10①-NP-2-1	Easy-to-use controller, even for beginners	3 points	AC100V	2.4A rated	-	→ P477
Splash-Proof Solenoid Valve Type		ASEP-C-10①-NP-2-0	Operable with same signal as solenoid valve. Supports both single and double solenoid types. No homing necessary with simple absolute type.				-	→ P487
Positioner Type		ACON-C-10①-NP-2-0	Positioning is possible for up to 512 points	512 points	DC24V	(Standard) 1.3A rated 4.4A max.	-	→ P535
Safety-Compliant Positioner Type		ACON-CG-10①-NP-2-0					-	
Pulse Train Input Type (Differential Line Driver)		ACON-PL-10①-NP-2-0	Pulse train input type with differential line driver support	(-)	DC24V	(Power-saving) 1.3A rated 2.5A max.	-	→ P535
Pulse Train Input Type (Open Collector)		ACON-PO-10①-NP-2-0	Pulse train input type with open collector support				-	
Serial Communication Type		ACON-SE-10①-N-0-0	Dedicated to serial communication	64 points	-	-	-	-
Field Network Type		RACON-10①	Dedicated to field network	768 points	-	-	-	→ P503
Program Control Type		ASEL-C-1-10①-NP-2-0	Programmed operation is possible Operation is possible on up to 2 axes	1500 points	-	-	-	→ P567

\* This is for the single-axis ASEL.

\* ① is a placeholder for the code "LA" if the power-saving option is specified.



# RCA2-TFA4N

ROBO Cylinder Mini Table Type Short-Length Flat Model 71mm Width  
24V Servo Motor Ball Screw/Lead Screw Models

■ Configuration: **RCA2** — **TFA4N** — **I** — **20** — **30** — **30** — **30** — **30**

Series — Type — Encoder — Motor — Lead — Stroke — Compatible Controllers — Cable Length — Option

I: Incremental  
\* The simple absolute encoder is also considered type "I".

20: 20W Servo motor

6: 6mm ball screw  
4: 4mm ball screw  
2: 2mm ball screw  
6S: 6mm lead screw  
4S: 4mm lead screw  
2S: 2mm lead screw

30: 30mm

A1: ACON  
RACON  
ASEL  
A3: AMEC  
ASEP

N: None  
P: 1m  
S: 3m  
M: 5m  
X   : Custom

K2: Connector cable exit direction  
LA: Power-saving

\* See page Pre-35 for an explanation of the naming convention.



Power-saving

Technical References P. A-5

**POINT**  
Notes on Selection

(1) The load capacity is based on operation at an acceleration of 0.3G (0.2G for the 2mm-lead model, or when used vertically). This is the upper limit of the acceleration.

(2) When using the Lead screw model, please ensure that your usage is appropriate for its characteristics. (See page Pre-42 for more information.)

### Actuator Specifications

#### Lead and Load Capacity

Model	Motor Output (W)	Feed Screw	Lead (mm)	Max. Load Capacity		Rated Thrust (N)	Positioning Repeatability (mm)	Stroke (mm)
				Horizontal (kg)	Vertical (kg)			
RCA2-TFA4N-I-20-6-30-①-②-③	20	Ball screw	6	2	0.5	33.8	±0.02	30 (Fixed)
RCA2-TFA4N-I-20-4-30-①-②-③			4	3	0.75	50.7		
RCA2-TFA4N-I-20-2-30-①-②-③			2	6	1.5	101.5		
RCA2-TFA4N-I-20-6S-30-①-②-③	20	Lead screw	6	0.25	0.125	19.9	±0.05	30 (Fixed)
RCA2-TFA4N-I-20-4S-30-①-②-③			4	0.5	0.25	29.8		
RCA2-TFA4N-I-20-2S-30-①-②-③			2	1	0.5	59.7		

Legend ① Compatible controller ② Cable length ③ Options

#### Stroke and Maximum Speed

Lead	Stroke (mm)	
	6	30
Ball screw	6	270 <220>
	4	200
	2	100
Lead screw	6	220
	4	200
	2	100

\* The values enclosed in "<" ">" apply to vertical usage. (Unit: mm/s)

#### Stroke List

Stroke (mm)	Standard Price	
	Feed Screw	
	Ball Screw Model	Lead Screw Model
30	-	-

#### ② Cable List

Type	Cable Symbol	Standard Price
Standard (Robot Cables)	P (1m)	-
	S (3m)	-
	M (5m)	-
Special Lengths	X06 (6m) ~ X10 (10m)	-
	X11 (11m) ~ X15 (15m)	-
	X16 (16m) ~ X20 (20m)	-
	-	-

\* The RCA2 comes standard with a robot cable.

\* See page A-39 for cables for maintenance.

#### ③ Option List

Name	Option Code	See Page	Standard Price
Connector cable exit direction	K2	→ A-32	-
Power-saving	LA	→ A-32	-

#### Actuator Specifications

Item	Description
Drive System	Ball screw/Lead screw ø6mm C10 grade
Lost Motion	Ball screw: 0.1mm or less/Lead screw: 0.3mm or less (initial value)
Frame	Material: Aluminum (white alumite treated)
Allowable Dynamic Moment (Note)	Ma: 9.9 N-m Mb: 9.9 N-m Mc: 3.3 N-m
Ambient Operating Temp./Humidity	0~40°C, 85% RH or less (non-condensing)
Service Life   Lead Screw Model	Horizontal: 10 million cycles Vertical: 5 million cycles

(Note) Based on a 5,000 km service life set for the guide.

Dimensions

CAD drawings can be downloaded from IAI website. [www.intelligentactuator.com](http://www.intelligentactuator.com)

For Special Orders P. A-9



- \*1 The motor-encoder cable is connected here. See page A-39 for details on cables.
  - \*2 When homing, the table moves to the mechanical end; therefore, please watch for any interference with the surrounding objects.
- ME: Mechanical end  
SE: Stroke end

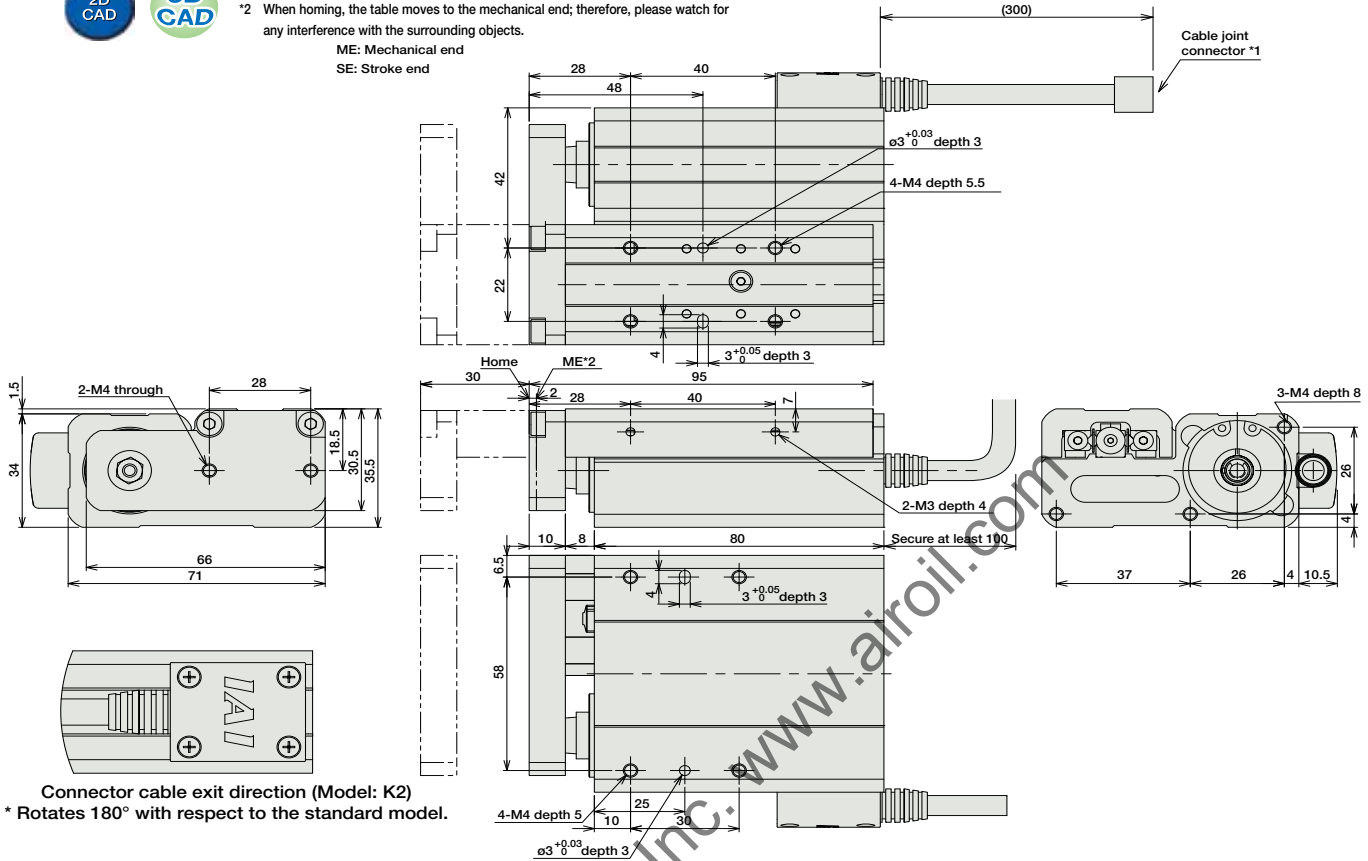

Connector cable exit direction (Model: K2)  
\* Rotates 180° with respect to the standard model.

■ Dimensions/Weight by Stroke

Stroke	30
Weight (kg)	0.6

① Compatible Controllers

The RCA2 series actuators can operate with the controllers below. Select the controller according to your usage.

Name	External View	Model	Description	Max. Positioning Points	Input Voltage	Power Supply Capacity	Standard Price	See Page
Solenoid Valve Type		AMEC-C-20①-NP-2-1	Easy-to-use controller, even for beginners	3 points	AC100V	2.4A rated	-	→ P477
		ASEP-C-20①-NP-2-0	Operable with same signal as solenoid valve. Supports both single and double solenoid types. No homing necessary with simple absolute type.					→ P487
Splash-Proof Solenoid Valve Type		ASEP-CW-20①-NP-2-0						
Positioner Type		ACON-C-20①-NP-2-0	Positioning is possible for up to 512 points	512 points	DC24V	(Standard) 1.3A rated 4.4A max.	-	→ P535
Safety-Compliant Positioner Type		ACON-CG-20①-NP-2-0						
Pulse Train Input Type (Differential Line Driver)		ACON-PL-20①-NP-2-0	Pulse train input type with differential line driver support	(-)	DC24V	(Power-saving) 1.3A rated 2.5A max.	-	→ P535
Pulse Train Input Type (Open Collector)		ACON-PO-20①-NP-2-0	Pulse train input type with open collector support					
Serial Communication Type		ACON-SE-20①-N-0-0	Dedicated to serial communication	64 points				
Field Network Type		RACON-20①	Dedicated to field network	768 points				→ P503
Program Control Type		ASEL-C-1-20①-NP-2-0	Programmed operation is possible Operation is possible on up to 2 axes	1500 points				→ P567

\* This is for the single-axis ASEL.  
\* ① is a placeholder for the code "LA" if the power-saving option is specified.

- Slider Type
- Mini
- Standard
- Controllers Integrated
- Rod Type
- Mini
- Standard
- Controllers Integrated
- Table/Arm/Flat Type
- Mini
- Standard
- Gripper/Rotary Type
- Linear Servo Type
- Cleanroom Type
- Splash Proof
- Controllers
- PMEC/AMEC
- PSEP/ASEP
- ROBO NET
- ERC2
- PCON
- ACON
- SCON
- PSEL
- ASEL
- SSEL
- XSEL
- Pulse Motor
- Servo Motor (24V)
- Servo Motor (200V)
- Linear Servo Motor

# RCA2-TA4C

ROBO Cylinder Mini Table Type Motor Unit Coupled 40mm Width  
24V Servo Motor Ball Screw

■ Configuration: **RCA2** — **TA4C** — **I** — **10** — [ ] — [ ] — [ ] — [ ] — [ ]

Series — Type — Encoder — Motor — Lead — Stroke — Compatible Controllers — Cable Length — Option

I: Incremental  
\* The simple absolute encoder is also considered type "I".

10: 10W Servo motor

6 : 6mm  
4 : 4mm  
2 : 2mm

20: 20mm  
100: 100mm (10mm pitch increments)

A1 : ACON  
RACON  
ASEL  
A3 : AMEC  
ASEP

N : None  
P : 1m  
S : 3m  
M : 5m  
X [ ] [ ] : Custom

K2 : Connector cable exit direction  
LA : Power-saving

\* See page Pre-35 for an explanation of the naming convention.

Power-saving

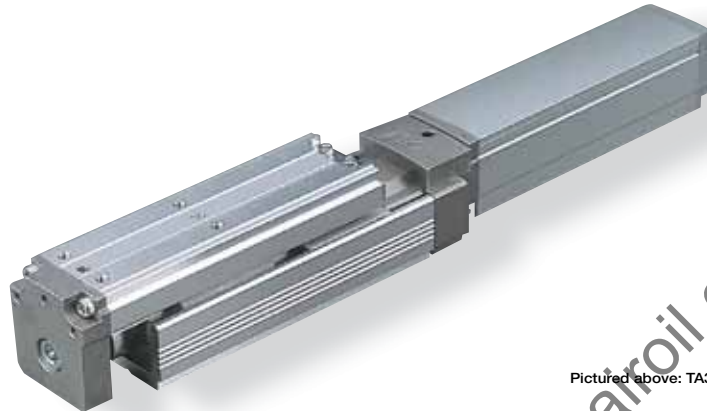

Pictured above: TA3C

Technical References P. A-5

**POINT**  
Notes on Selection

(1) The load capacity is based on operation at an acceleration of 0.3G (0.2G for the 2mm-lead model, or when used vertically). 0.3G (0.2G for 2mm lead) is the upper limit of the acceleration.

Actuator Specifications

■ Lead and Load Capacity

Model	Motor Output (W)	Feed Screw	Lead (mm)	Max. Load Capacity		Rated Thrust (N)	Positioning Repeatability (mm)	Stroke (mm)
				Horizontal (kg)	Vertical (kg)			
RCA2-TA4C-I-10-6-①-②-③-④	10	Ball screw	6	1	0.5	28	±0.02	20~100 (10mm increments)
RCA2-TA4C-I-10-4-①-②-③-④			4	2	1	43		
RCA2-TA4C-I-10-2-①-②-③-④			2	3	1.5	85		

Legend ① Stroke ② Compatible controller ③ Cable length ④ Options

■ Stroke and Maximum Speed

Lead	Stroke	
	20 ~ 100 (10mm increments)	20 ~ 100 (10mm increments)
Ball screw	6	300
	4	200
	2	100

(Unit: mm/s)

① Stroke List

Stroke (mm)	Standard Price
20	-
30	-
40	-
50	-
60	-
70	-
80	-
90	-
100	-

③ Cable List

Type	Cable Symbol	Standard Price
Standard (Robot Cables)	P (1m)	-
	S (3m)	-
	M (5m)	-
Special Lengths	X06 (6m) ~ X10 (10m)	-
	X11 (11m) ~ X15 (15m)	-
	X16 (16m) ~ X20 (20m)	-
		-

\* The RCA2 comes standard with a robot cable.  
\* See page A-39 for cables for maintenance.

④ Option List

Name	Option Code	See Page	Standard Price
Brake	B	→ A-25	-
Cable exit direction (Top)	CJT	→ A-25	-
Cable exit direction (Right)	CJR		
Cable exit direction (Left)	CJL		
Cable exit direction (Bottom)	CJB		
Power-saving	LA	→ A-32	-
Reversed-home	NM	→ A-33	-

Actuator Specifications

Item	Description
Drive System	Ball screw ø6mm C10 grade
Lost Motion	0.1mm or less
Base	Material: Aluminum (white alumite treated)
Allowable Dynamic Moment (Note)	Ma: 4.2 N·m Mb: 6 N·m Mc: 8.2 N·m
Ambient Operating Temp./Humidity	0~40°C, 85% RH or less (non-condensing)

(Note) Based on a 5,000km service life.

Directions of Allowable Load Moments

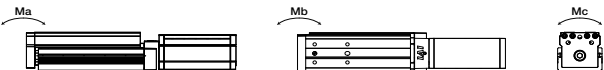

Dimensions

CAD drawings can be downloaded from IAI website. [www.intelligentactuator.com](http://www.intelligentactuator.com)

For Special Order

P. A-9

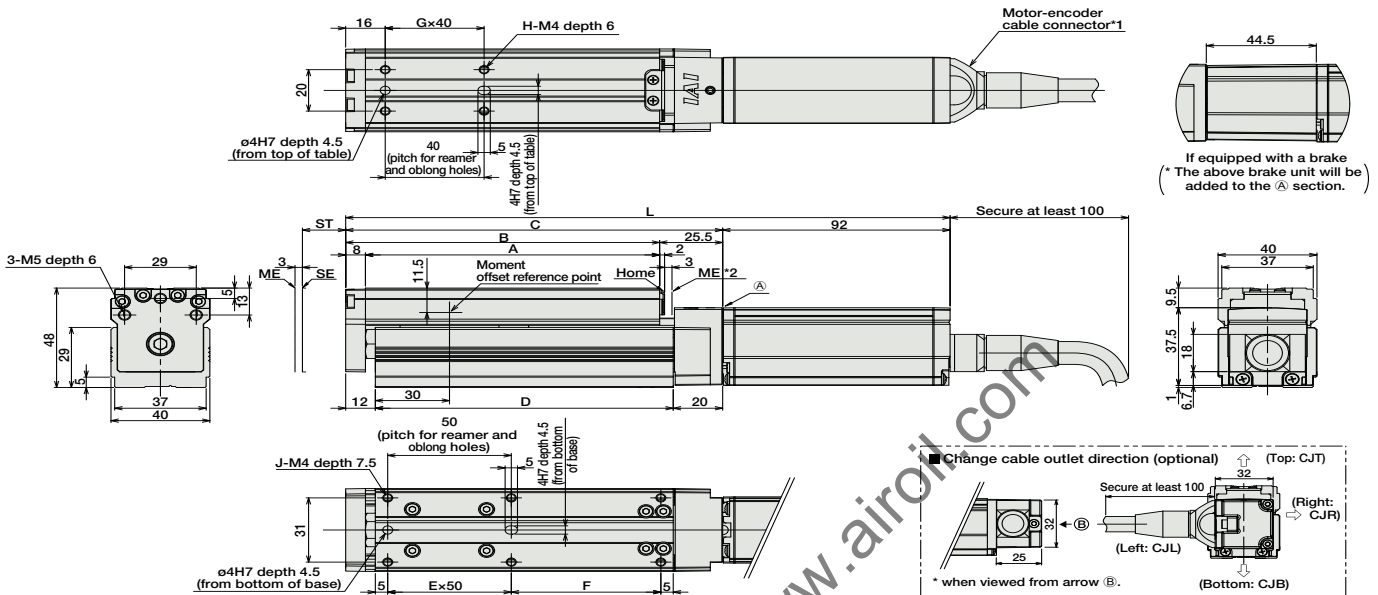

- \*1 The motor-encoder cable is connected directly to the motor cover of the actuator. See page A-39 for details on cables.
- \*2 When homing, the slider moves to the mechanical end; therefore, please watch for any interference with the surrounding objects.  
ST : Stroke  
ME : Mechanical end  
SE : Stroke end

■ Dimensions/Weight by Stroke \* Adding a brake will increase the actuator's weight by 0.2kg.

Stroke	20	30	40	50	60	70	80	90	100
No Brake	214.5	224.5	234.5	244.5	254.5	264.5	274.5	284.5	294.5
Brake-equipped	259	269	279	289	299	309	319	329	339
A	89	99	109	119	129	139	149	159	169
B	97	107	117	127	137	147	157	167	177
C	122.5	132.5	142.5	152.5	162.5	172.5	182.5	192.5	202.5
D	90.5	100.5	110.5	120.5	130.5	140.5	150.5	160.5	170.5
E	1	1	1	1	2	2	2	2	2
F	30.5	40.5	50.5	60.5	20.5	30.5	40.5	50.5	60.5
G	1	1	1	1	2	2	2	2	2
H	4	4	4	4	6	6	6	6	6
J	6	6	6	6	8	8	8	8	8
Weight (kg)	0.8	0.8	0.8	0.9	0.9	0.9	1.0	1.0	1.0

② Compatible Controllers

The RCA2 series actuators can operate with the controllers below. Select the controller according to your usage.

Name	External View	Model	Description	Max. Positioning Points	Input Voltage	Power Supply Capacity	Standard Price	See Page							
Solenoid Valve Type		AMEC-C-10①-NP-2-1	Easy-to-use controller, even for beginners	3 points	AC100V	2.4A rated	-	→ P477							
		ASEP-C-10①-NP-2-0	Operable with same signal as solenoid valve. Supports both single and double solenoid types. No homing necessary with simple absolute type.						→ P487						
Splash-Proof Solenoid Valve Type		ASEP-CW-10①-NP-2-0													
Positioner Type		ACON-C-10①-NP-2-0	Positioning is possible for up to 512 points	512 points				DC24V	(Standard) 1.3A rated 4.4A max.	-					
Safety-Compliant Positioner Type		ACON-CG-10①-NP-2-0													
Pulse Train Input Type (Differential Line Driver)		ACON-PL-10①-NP-2-0	Pulse train input type with differential line driver support	(-)							(Power-saving) 1.3A rated 2.5A max.	-	→ P535		
Pulse Train Input Type (Open Collector)		ACON-PO-10①-NP-2-0	Pulse train input type with open collector support												
Serial Communication Type		ACON-SE-10①-N-0-0	Dedicated to serial communication	64 points											
Field Network Type		RACON-10①	Dedicated to field network	768 points											→ P503
Program Control Type		ASEL-C-1-10①-NP-2-0	Programmed operation is possible. Operation is possible on up to 2 axes	1500 points			→ P567								

\* This is for the single-axis ASEL.  
\* ① is a placeholder for the code "LA" if the power-saving option is specified.

# RCA2-TA5C

ROBO Cylinder Table Type Motor Unit Coupled 55mm Width 24V Servo Motor Ball Screw

■ Configuration: **RCA2** — **TA5C** — **I** — **20** —  —  —  —  —

Series — Type — Encoder — Motor — Lead — Stroke — Compatible Controllers — Cable Length — Option

I: Incremental  
\* The simple absolute encoder is also considered type "I".

20: 20W Servo motor

10: 10mm  
5: 5mm  
2.5: 2.5mm

25: 25mm  
100: 100mm (25mm pitch increments)

A1: ACON  
RACON  
ASEL  
A3: AMEC  
ASEP

N: None  
P: 1m  
S: 3m  
M: 5m  
X   : Custom

See Options below

\* See page Pre-35 for an explanation of the naming convention.

Power-saving

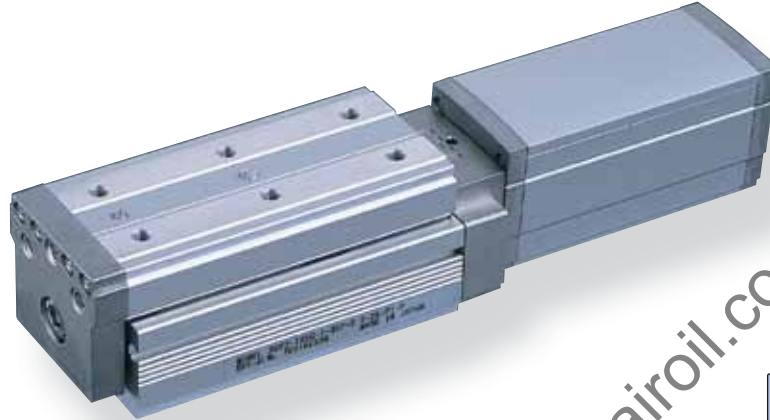

Technical References P. A-5

**POINT**  
Notes on Selection

- Please note that the maximum speed is different when used horizontally versus vertically.
- The load capacity is based on operation at an acceleration of 0.3G (0.2G for the 2.5mm-lead model, or when used vertically). This is the upper limit of the acceleration.

### Actuator Specifications

#### Lead and Load Capacity

Model	Motor Output (W)	Lead (mm)	Max. Load Capacity		Rated Thrust (N)	Stroke (mm)
			Horizontal (kg)	Vertical (kg)		
RCA2-TA5C-I-20-10- <input type="checkbox"/> - <input type="checkbox"/> - <input type="checkbox"/> - <input type="checkbox"/>	20	10	2	1	34	25~100 (25mm increments)
RCA2-TA5C-I-20-5- <input type="checkbox"/> - <input type="checkbox"/> - <input type="checkbox"/> - <input type="checkbox"/>		5	3.5	2	68	
RCA2-TA5C-I-20-2.5- <input type="checkbox"/> - <input type="checkbox"/> - <input type="checkbox"/> - <input type="checkbox"/>		2.5	5	3	137	

Legend:  Stroke  Compatible controller  Cable length  Options

#### Stroke and Maximum Speed

Stroke Lead	25 ~ 100 (25mm increments)	
	10	465 <400>
5	250	
2.5	125	

\* The values enclosed in "<" ">" apply to vertical usage. (Unit: mm/s)

#### ① Stroke List

Stroke (mm)	Standard Price
25	-
50	-
75	-
100	-

#### ③ Cable List

Type	Cable Symbol	Standard Price
Standard Type (Robot Cables)	P (1m)	-
	S (3m)	-
	M (5m)	-
Special Lengths	X06 (6m) ~ X10 (10m)	-
	X11 (11m) ~ X15 (15m)	-
	X16 (16m) ~ X20 (20m)	-
		-

\* The RCA2 comes standard with a robot cable.

\* See page A-39 for cables for maintenance.

#### ④ Options List

Name	Option Code	Standard Price	Standard Price
Brake	B	→ A-25	-
Cable exit direction (Top)	CJT	→ A-25	-
Cable exit direction (Right)	CJR	→ A-25	-
Cable exit direction (Left)	CJL	→ A-25	-
Cable exit direction (Bottom)	CJB	→ A-25	-
Power-saving	LA	→ A-32	-
Reversed-home	NM	→ A-33	-

#### Actuator Specifications

Item	Description
Drive System	Ball screw ø8mm C10 grade
Positioning Repeatability	±0.02mm
Lost Motion	0.1mm or less
Base	Material: Aluminum (special alumite treated)
Allowable Static Moment	Ma: 25.5 N·m Mb: 36.5 N·m Mc: 56.1 N·m
Allowable Dynamic Moment (*)	Ma: 6.57 N·m Mb: 9.32 N·m Mc: 14.32 N·m
Overhang Load Length	Within the load moment range
Ambient Operating Temp./Humidity	0~40°C, 85% RH or less (non-condensing)

(\*) Based on a 5,000km service life.

Directions of Allowable Load Moments



Dimensions

CAD drawings can be downloaded from IAI website. [www.intelligentactuator.com](http://www.intelligentactuator.com)

For Special Order P. A-9

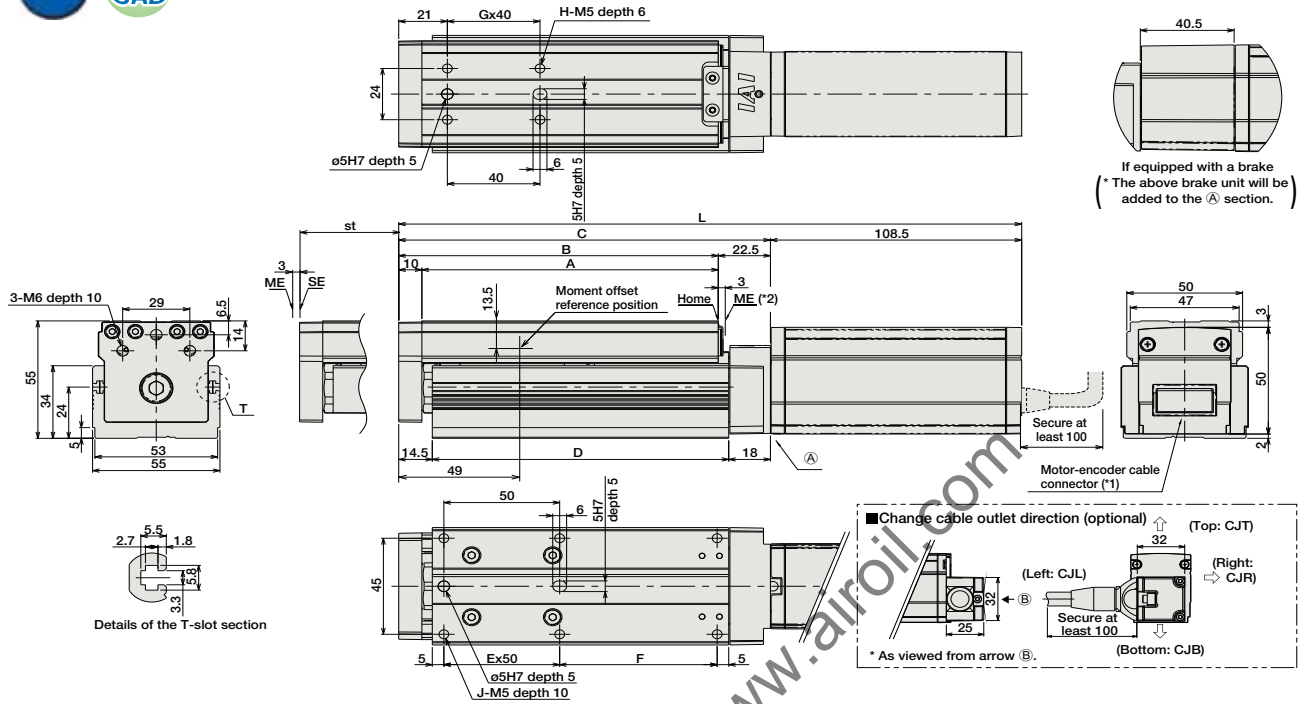

Dimensions and Weight by Stroke \* Adding a brake will increase the actuator's weight by 0.3kg.

Stroke	L			
	No brake	25	50	75
L	244	269	294	319
Brake-equipped	284.5	309.5	334.5	359.5
A	103	128	153	178
B	113	138	163	188
C	135.5	160.5	185.5	210.5
D	103	128	153	178
E	1	1	2	2
F	43	68	43	68
G	1	1	2	2
H	4	4	6	6
J	6	6	8	8
Weight (kg)	1.2	1.4	1.5	1.7

(\*1) The motor-encoder cable is connected directly to the motor cover of the actuator. See page A-39 for details on cables.  
 (\*2) After homing, the slider moves to the ME; therefore, please watch for any interference with the surrounding objects.  
 ME: Mechanical end  
 SE: Stroke end

② Compatible Controllers

The RCA2 series actuators can operate with the controllers below. Select the controller according to your usage.

Name	External View	Model	Description	Max. Positioning Points	Input Voltage	Power Supply Capacity	Standard Price	See Page			
Solenoid Valve Type		AMEC-C-20SI①-NP-2-1	Easy-to-use controller, even for beginners	3 points	AC100V	2.4A rated	-	→ P477			
		ASEP-C-20SI①-NP-2-0	Operable with same signal as solenoid valve. Supports both single and double solenoid types. No homing necessary with simple absolute type.						→ P487		
Splash-Proof Solenoid Valve Type		ASEP-CW-20SI①-NP-2-0									
Positioner Type		ACON-C-20SI①-NP-2-0	Positioning is possible for up to 512 points	512 points							
Safety-Compliant Positioner Type		ACON-CG-20SI①-NP-2-0									
Pulse Train Input Type (Differential Line Driver)		ACON-PL-20SI①-NP-2-0	Pulse train input type with differential line driver support	(-)				DC24V	(Standard) 1.3A rated 4.4A max.  (Power-saving) 1.3A rated 2.5A max.	-	→ P535
Pulse Train Input Type (Open Collector)		ACON-PO-20SI①-NP-2-0	Pulse train input type with open collector support								
Serial Communication Type		ACON-SE-20SI①-N-0-0	Dedicated to serial communication	64 points							
Field Network Type		RACON-20S①	Dedicated to field network	768 points							→ P503
Program Control Type		ASEL-C-1-20SI①-NP-2-0	Programmed operation is possible Operation is possible on up to 2 axes	1500 points	→ P567						

\* This is for the single-axis ASEL.  
 \* ① is a placeholder for the code "LA", if the power-saving option is specified.

- Slider Type
- Mini
- Standard
- Controllers Integrated
- Rod Type
- Mini
- Standard
- Controllers Integrated
- Table/Arm/Flat Type
- Mini
- Standard
- Gripper/Rotary Type
- Linear Servo Type
- Cleanroom Type
- Splash Proof
- Controllers
- PMEC/AMEC
- PSEP/ASEP
- ROBO NET
- ERC2
- PCON
- ACON
- SCON
- PSEL
- ASEL
- SSEL
- XSEL
- Pulse Motor
- Servo Motor (24V)
- Servo Motor (200V)
- Linear Servo Motor

# RCA2-TA6C

ROBO Cylinder Table Type Motor Unit Coupled 65mm Width 24V Servo Motor Ball Screw

■ Configuration: **RCA2** — **TA6C** — **I** — **20** —  —  —  —  —

Series	Type	Encoder	Motor	Lead	Stroke	Compatible Controllers	Cable Length	Option
		I: Incremental * The simple absolute encoder is also considered type "I".	20: 20W Servo motor	12: 12mm 6: 6mm 3: 3mm	25: 25mm 150: 150mm (25mm pitch increments)	A1: ACON RACON ASEL A3: AMEC ASEP	N: None P: 1m S: 3m M: 5m X <input type="checkbox"/> : Custom	See Options below

\* See page Pre-35 for an explanation of the naming convention.

Power-saving

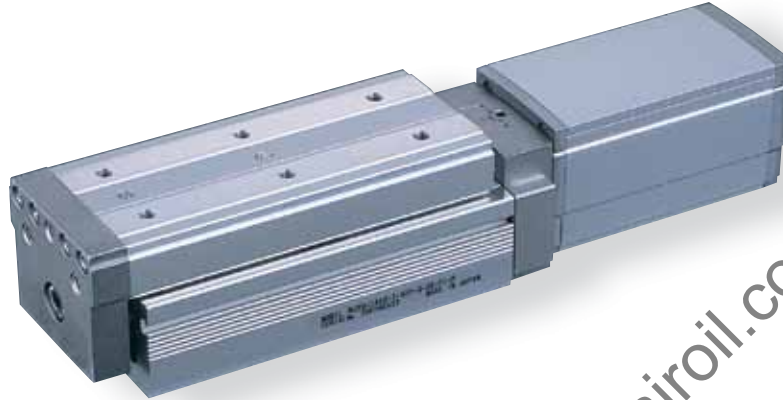

Technical References P. A-5

**POINT**  
Notes on Selection

- (1) Please note that the maximum speed is different when used horizontally versus vertically.
- (2) The load capacity is based on operation at an acceleration of 0.3G (0.2G for the 3mm-lead model, or when used vertically). This is the upper limit of the acceleration.

Actuator Specifications

■ Lead and Load Capacity

Model	Motor Output (W)	Lead (mm)	Max. Load Capacity		Rated Thrust (N)	Stroke (mm)
			Horizontal (kg)	Vertical (kg)		
RCA2-TA6C-I-20-12-①-②-③-④	20	12	2	0.5	17	25~150 (25mm increments)
RCA2-TA6C-I-20-6-①-②-③-④		6	4	1.5	34	
RCA2-TA6C-I-20-3-①-②-③-④		3	6	3	68	

■ Stroke and Maximum Speed

Stroke Lead	25 ~ 150 (25mm increments)	
	12	560 <500>
6	300	
3	150	

Legend: ① Stroke ② Compatible controller ③ Cable length ④ Options

\* The values enclosed in "< >" apply to vertical usage. (Unit: mm/s)

① Stroke List

Stroke (mm)	Standard Price
25	-
50	-
75	-
100	-
125	-
150	-

③ Cable List

Type	Cable Symbol	Standard Price
Standard Type (Robot Cables)	P (1m)	-
	S (3m)	-
	M (5m)	-
Special Lengths	X06 (6m) ~ X10 (10m)	-
	X11 (11m) ~ X15 (15m)	-
	X16 (16m) ~ X20 (20m)	-
		-

\* The RCA2 comes standard with a robot cable.

\* See page A-39 for cables for maintenance.

④ Options List

Name	Option Code	Standard Price	Standard Price
Brake	B	→ A-25	-
Cable exit direction (Top)	CJT	→ A-25	-
Cable exit direction (Right)	CJR	→ A-25	-
Cable exit direction (Left)	CJL	→ A-25	-
Cable exit direction (Bottom)	CJB	→ A-25	-
Power-saving	LA	→ A-32	-
Reversed-home	NM	→ A-33	-

Actuator Specifications

Item	Description
Drive System	Ball screw ø10mm C10 grade
Positioning Repeatability	±0.02mm
Lost Motion	0.1mm or less
Base	Material: Aluminum (special alumite treated)
Allowable Static Moment	Ma: 29.4 N·m Mb: 42.0 N·m Mc: 74.1 N·m
Allowable Dynamic Moment (*)	Ma: 7.26 N·m Mb: 10.3 N·m Mc: 18.25 N·m
Overhang Load Length	Within the load moment range
Ambient Operating Temp./Humidity	0~40°C, 85% RH or less (non-condensing)

(\*) Based on a 5,000km service life.

Directions of Allowable Load Moments

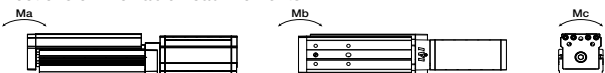

Dimensions

CAD drawings can be downloaded from IAI website. [www.intelligentactuator.com](http://www.intelligentactuator.com)

For Special Order P. A-9

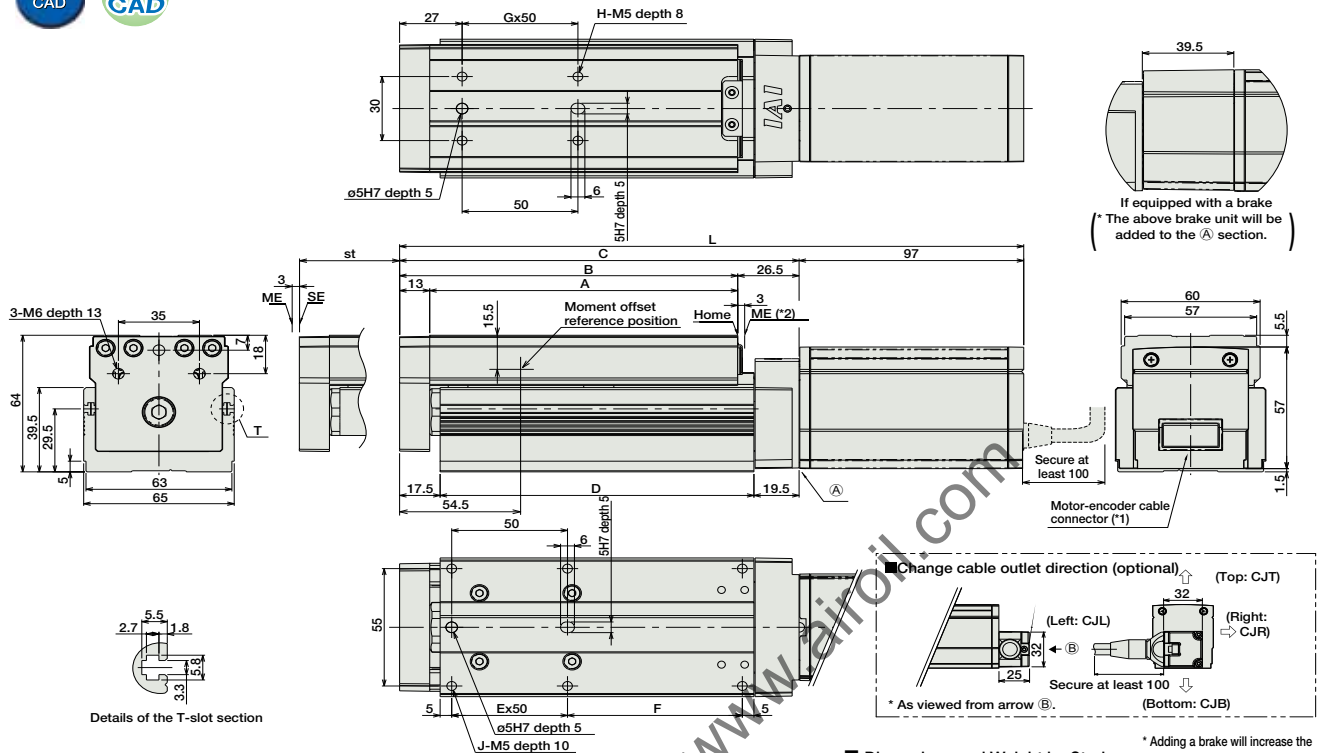

■ Dimensions and Weight by Stroke

Stroke	L					
	25	50	75	100	125	150
No brake	244.5	269.5	294.5	319.5	344.5	369.5
Brake-equipped	284	309	334	359	384	409
A	108	133	158	183	208	233
B	121	146	171	196	221	246
C	147.5	172.5	197.5	222.5	247.5	272.5
D	110.5	135.5	160.5	185.5	210.5	235.5
E	1	1	2	2	3	3
F	50.5	75.5	50.5	75.5	50.5	75.5
G	1	1	2	2	3	3
H	4	4	6	6	8	8
J	6	6	8	8	10	10
Weight (kg)	1.8	2	2.2	2.4	2.6	2.8

(\*1) The motor-encoder cable is connected directly to the motor cover of the actuator. See page A-39 for details on cables.  
 (\*2) After homing, the slider moves to the ME; therefore, please watch for any interference with the surrounding objects.  
 ME: Mechanical end  
 SE: Stroke end

② Compatible Controllers

The RCA2 series actuators can operate with the controllers below. Select the controller according to your usage.

Name	External View	Model	Description	Max. Positioning Points	Input Voltage	Power Supply Capacity	Standard Price	See Page
Solenoid Valve Type		AMEC-C-20①-NP-2-1	Easy-to-use controller, even for beginners	3 points	AC100V	2.4A rated	-	→ P477
		ASEP-C-20①-NP-2-0	Operable with same signal as solenoid valve. Supports both single and double solenoid types. No homing necessary with simple absolute type.					
Splash-Proof Solenoid Valve Type		ASEP-CW-20①-NP-2-0						→ P487
Positioner Type		ACON-C-20①-NP-2-0	Positioning is possible for up to 512 points	512 points	DC24V	(Standard) 1.3A rated 4.4A max.	-	
Safety-Compliant Positioner Type		ACON-CG-20①-NP-2-0						
Pulse Train Input Type (Differential Line Driver)		ACON-PL-20①-NP-2-0	Pulse train input type with differential line driver support	(-)	DC24V	(Power-saving) 1.3A rated 2.5A max.	-	→ P535
Pulse Train Input Type (Open Collector)		ACON-PO-20①-NP-2-0	Pulse train input type with open collector support					
Serial Communication Type		ACON-SE-20①-N-0-0	Dedicated to serial communication	64 points				
Field Network Type		RACON-20①	Dedicated to field network	768 points				→ P503
Program Control Type		ASEL-C-1-20①-NP-2-0	Programmed operation is possible. Operation is possible on up to 2 axes	1500 points				→ P567

\* This is for the single-axis ASEL.  
 \* ① is a placeholder for the code "LA", if the power-saving option is specified.



# RCA2-TA7C

ROBO Cylinder Table Type Motor Unit Coupled 75mm Width 24V Servo Motor Ball Screw

■ Configuration: **RCA2** — **TA7C** — **I** — **30** —  —  —  —  —

Series	Type	Encoder	Motor	Lead	Stroke	Compatible Controllers	Cable Length	Option
		I: Incremental * The simple absolute encoder is also considered type "I".	30: 30W Servo motor	12: 12mm 6: 6mm 3: 3mm	25: 25mm ↓ 200: 200mm (25mm pitch increments)	A1: ACON RACON ASEL A3: AMEC ASEP	N: None P: 1m S: 3m M: 5m X <input type="checkbox"/> : Custom	See Options below

\* See page Pre-35 for an explanation of the naming convention.

Power-saving

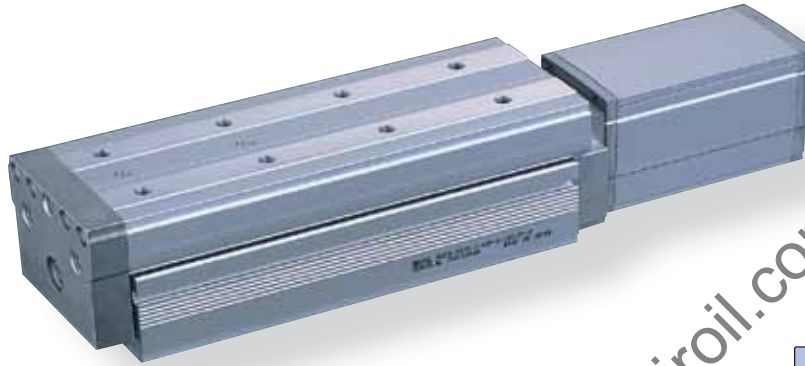

Technical References P. A-5

**POINT**  
Notes on Selection

- Please note that the maximum speed is different when used horizontally versus vertically.
- The load capacity is based on operation at an acceleration of 0.3G (0.2G for the 3mm-lead model, or when used vertically). This is the upper limit of the acceleration.

### Actuator Specifications

#### Lead and Load Capacity

Model	Motor Output (W)	Lead (mm)	Max. Load Capacity		Rated Thrust (N)	Stroke (mm)
			Horizontal (kg)	Vertical (kg)		
RCA2-TA7C-I-30-12-①-②-③-④	30	12	4	1	26	25~200 (25mm increments)
RCA2-TA7C-I-30-6-①-②-③-④		6	6	2.5	53	
RCA2-TA7C-I-30-3-①-②-③-④		3	8	4	105	

#### Stroke and Maximum Speed

Stroke Lead	25 ~ 200 (25mm increments)	
	12	600 <580>
6	300	
3	150	

Legend: ① Stroke ② Compatible controller ③ Cable length ④ Options

\* The values enclosed in "<" ">" apply to vertical usage. (Unit: mm/s)

#### ① Stroke List

Stroke (mm)	Standard Price
25	-
50	-
75	-
100	-
125	-
150	-
175	-
200	-

#### ③ Cable List

Type	Cable Symbol	Standard Price
Standard Type (Robot Cables)	P (1m)	-
	S (3m)	-
	M (5m)	-
Special Lengths	X06 (6m) ~ X10 (10m)	-
	X11 (11m) ~ X15 (15m)	-
	X16 (16m) ~ X20 (20m)	-
		-

\* The RCA2 comes standard with a robot cable.

\* See page A-39 for cables for maintenance.

#### ④ Options List

Name	Option Code	Standard Price	Standard Price
Brake	B	→ A-25	-
Cable exit direction (Top)	CJT	→ A-25	-
Cable exit direction (Right)	CJR	→ A-25	-
Cable exit direction (Left)	CJL	→ A-25	-
Cable exit direction (Bottom)	CJB	→ A-25	-
Power-saving	LA	→ A-32	-
Reversed-home	NM	→ A-33	-

#### Actuator Specifications

Item	Description
Drive System	Ball screw $\phi$ 10mm C10 grade
Positioning Repeatability	$\pm$ 0.02mm
Lost Motion	0.1mm or less
Base	Material: Aluminum (special alumite treated)
Allowable Static Moment	Ma: 42.6 N·m Mb: 60.8 N·m Mc: 123.2 N·m
Allowable Dynamic Moment (*)	Ma: 9.91 N·m Mb: 14.13 N·m Mc: 28.65 N·m
Overhang Load Length	Within the load moment range
Ambient Operating Temp./Humidity	0~40°C, 85% RH or less (non-condensing)

(\*) Based on a 5,000km service life.

Directions of Allowable Load Moments



Dimensions

CAD drawings can be downloaded from IAI website. [www.intelligentactuator.com](http://www.intelligentactuator.com)

For Special Order P. A-9

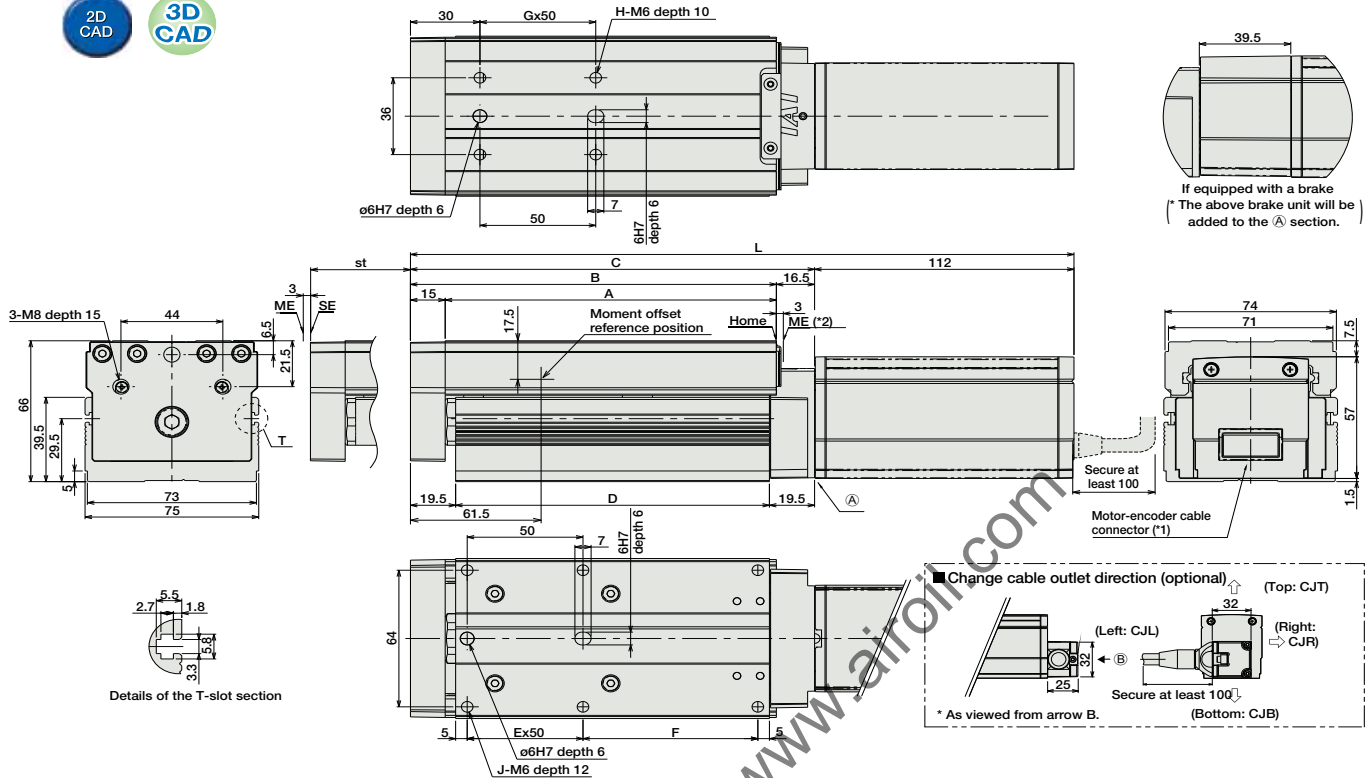

Details of the T-slot section

■ Dimensions and Weight by Stroke \* Adding a brake will increase the actuator's weight by 0.4kg.

Stroke	Stroke								
	25	50	75	100	125	150	175	200	
L	No brake	261.5	286.5	311.5	336.5	361.5	386.5	411.5	436.5
	Brake-equipped	301	326	351	376	401	426	451	476
A	118	143	168	193	218	243	268	293	
B	133	158	183	208	233	258	283	308	
C	149.5	174.5	199.5	224.5	249.5	274.5	299.5	324.5	
D	110.5	135.5	160.5	185.5	210.5	235.5	260.5	285.5	
E	1	1	2	2	3	3	4	4	
F	50.5	75.5	50.5	75.5	50.5	75.5	50.5	75.5	
G	1	1	2	2	3	3	4	4	
H	4	4	6	6	8	8	10	10	
J	6	6	8	8	10	10	12	12	
Weight (kg)	2.1	2.3	2.5	2.8	3	3.2	3.4	3.6	

(\*1) The motor-encoder cable is connected directly to the motor cover of the actuator. See page A-39 for details on cables.

(\*2) After homing, the slider moves to the ME; therefore, please watch for any interference with the surrounding objects.

ME: Mechanical end  
SE: Stroke end

② Compatible Controllers

The RCA2 series actuators can operate with the controllers below. Select the controller according to your usage.

Name	External View	Model	Description	Max. Positioning Points	Input Voltage	Power Supply Capacity	Standard Price	See Page
Solenoid Valve Type		AMEC-C-30①-NP-2-1	Easy-to-use controller, even for beginners	3 points	AC100V	2.4A rated	-	→ P477
		ASEP-C-30①-NP-2-0	Operable with same signal as solenoid valve. Supports both single and double solenoid types. No homing necessary with simple absolute type.					
Splash-Proof Solenoid Valve Type		ASEP-CW-30①-NP-2-0						→ P487
Positioner Type		ACON-C-30①-NP-2-0	Positioning is possible for up to 512 points	512 points	DC24V	(Standard) 1.3A rated 4.0A max.	-	
Safety-Compliant Positioner Type		ACON-CG-30①-NP-2-0						
Pulse Train Input Type (Differential Line Driver)		ACON-PL-30①-NP-2-0	Pulse train input type with differential line driver support	(-)	DC24V	(Power-saving) 1.3A rated 2.2A max.	-	→ P535
Pulse Train Input Type (Open Collector)		ACON-PO-30①-NP-2-0	Pulse train input type with open collector support					
Serial Communication Type		ACON-SE-30①-N-0-0	Dedicated to serial communication	64 points				
Field Network Type		RACON-30①	Dedicated to field network	768 points				→ P503
Program Control Type		ASEL-C-1-30①-NP-2-0	Programmed operation is possible. Operation is possible on up to 2 axes	1500 points				→ P567

\* This is for the single-axis ASEL.  
\* ① is a placeholder for the code "LA", if the power-saving option is specified.

# RCA2-TA4R

ROBO Cylinder Mini Table Type Side-Mounted Motor 40mm Width 24V Servo Motor Ball Screw

■ Configuration: **RCA2** — **TA4R** — **I** — **10** —  —  —  —  —

Series	Type	Encoder	Motor	Lead	Stroke	Compatible Controllers	Cable Length	Option
RCA2	TA4R	I: Incremental * The simple absolute encoder is also considered type "I".	10: 10W Servo motor	6 : 6mm 4 : 4mm 2 : 2mm	20: 20mm ↓ 100: 100mm (10mm pitch increments)	A1 : ACON RACON ASEL A3 : AMEC ASEP	N : None P : 1m S : 3m M : 5m X <input type="checkbox"/> : Custom	See Options below * Be sure to specify which side the motor is to be mounted (ML/MR).

\* See page Pre-35 for an explanation of the naming convention.

Power-saving



Pictured: TA4R with left-mounted motor (ML).

Technical References P. A-5



(1) The load capacity is based on operation at an acceleration of 0.3G (0.2G for the 2mm-lead model, or when used vertically). 0.3G (0.2G for 2mm lead) is the upper limit of the acceleration.

### Actuator Specifications

#### ■ Lead and Load Capacity

Model	Motor Output (W)	Feed Screw	Lead (mm)	Max. Load Capacity		Rated Thrust (N)	Positioning Repeatability (mm)	Stroke (mm)
				Horizontal (kg)	Vertical (kg)			
RCA2-TA4R-I-10-6-①-②-③-④	10	Ball screw	6	1	0.5	28	±0.02	20~100 (10mm increments)
RCA2-TA4R-I-10-4-①-②-③-④			4	2	1	43		
RCA2-TA4R-I-10-2-①-②-③-④			2	3	1.5	85		

Legend: ① Stroke ② Compatible controller ③ Cable length ④ Options

#### ■ Stroke and Maximum Speed

Lead	Stroke	20 ~ 100 (10mm increments)
	Ball screw	6
	4	200
	2	100

(Unit: mm/s)

#### ① Stroke List

Stroke (mm)	Standard Price
20	-
30	-
40	-
50	-
60	-
70	-
80	-
90	-
100	-

#### ③ Cable List

Type	Cable Symbol	Standard Price
Standard Type (Robot Cables)	P (1m)	-
	S (3m)	-
	M (5m)	-
Special Lengths	X06 (6m) ~ X10 (10m)	-
	X11 (11m) ~ X15 (15m)	-
	X16 (16m) ~ X20 (20m)	-

\* The RCA2 comes standard with a robot cable.  
\* See page A-39 for cables for maintenance.

#### ④ Option List

Name	Option Code	See Page	Standard Price
Brake	B	→ A-25	-
Cable exit direction (Top)	CJT	→ A-25	-
Cable exit direction (Outside)	CJO		
Cable exit direction (Bottom)	CJB		
Power-saving	LA	→ A-32	-
Left-mounted Motor (Standard)	ML	→ A-33	-
Right-mounted motor	MR	→ A-33	-
Reversed-home	NM	→ A-33	-

#### Actuator Specifications

Item	Description
Drive System	Ball screw ø6mm C10 grade
Lost Motion	0.1mm or less
Base	Material: Aluminum (white alumite treated)
Allowable Dynamic Moment (Note)	Ma: 4.2 N·m Mb: 6 N·m Mc: 8.2 N·m
Ambient Operating Temp./Humidity	0~40°C, 85% RH or less (non-condensing)

(Note) Based on a 5,000km service life.

Dimensions

CAD drawings can be downloaded from IAI website. [www.intelligentactuator.com](http://www.intelligentactuator.com)

For Special Order P. A-9



\* The diagram below shows a left-mounted motor model.

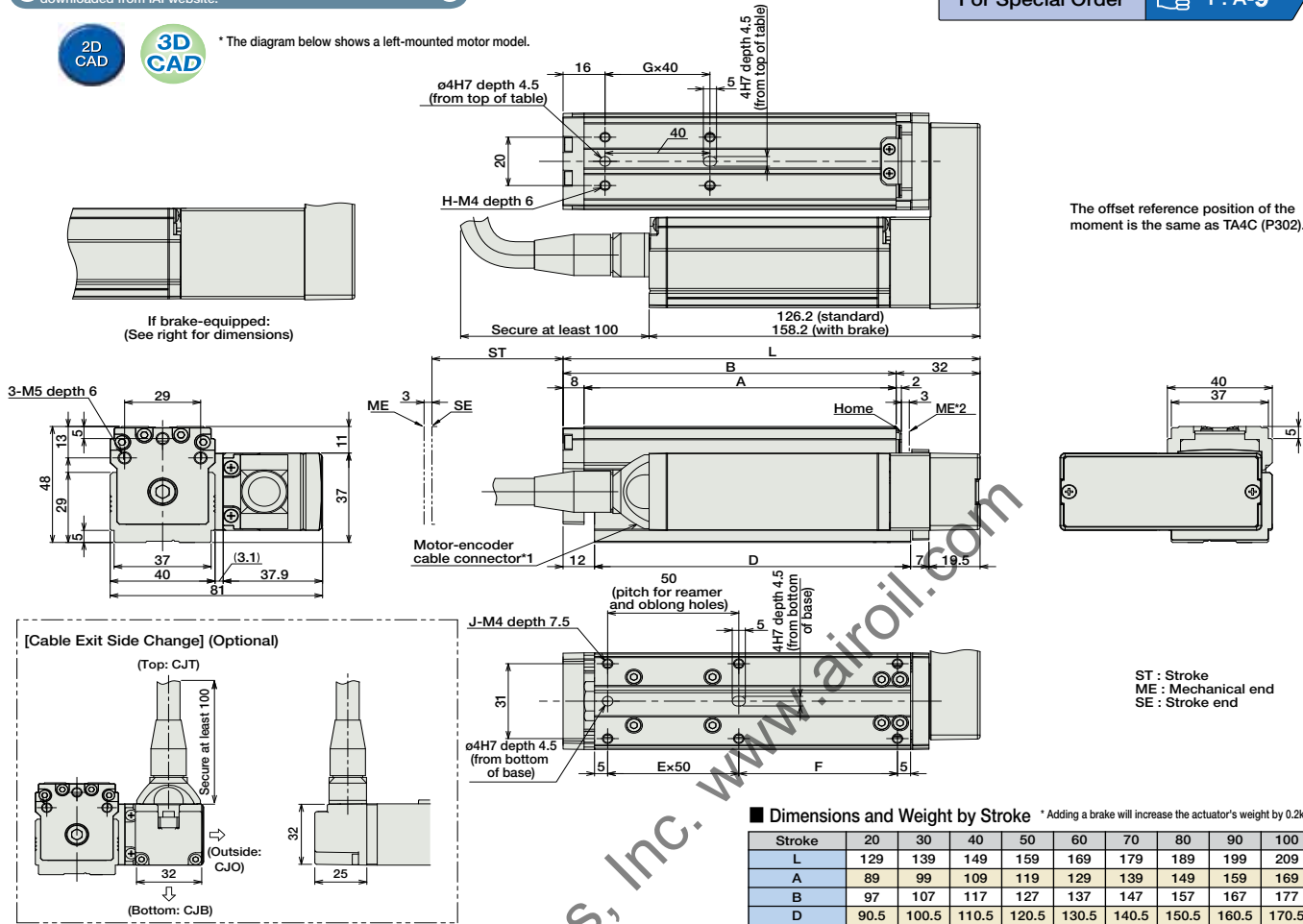

The offset reference position of the moment is the same as TA4C (P302).

ST : Stroke  
ME : Mechanical end  
SE : Stroke end

■ Dimensions and Weight by Stroke \* Adding a brake will increase the actuator's weight by 0.2kg.

Stroke	20	30	40	50	60	70	80	90	100
L	129	139	149	159	169	179	189	199	209
A	89	99	109	119	129	139	149	159	169
B	97	107	117	127	137	147	157	167	177
D	90.5	100.5	110.5	120.5	130.5	140.5	150.5	160.5	170.5
E	1	1	1	1	2	2	2	2	2
F	30.5	40.5	50.5	60.5	20.5	30.5	40.5	50.5	60.5
G	1	1	1	1	2	2	2	2	2
H	4	4	4	4	6	6	6	6	6
J	6	6	6	6	8	8	8	8	8
Weight (kg)	0.8	0.9	0.9	0.9	1.0	1.0	1.0	1.1	1.1

\*1 The motor-encoder cable is connected directly to the motor cover of the actuator. See page A-39 for details on cables.  
\*2 When homing, the slider moves to the mechanical end; therefore, please watch for any interference with the surrounding objects.

② Compatible Controllers

The RCA2 series actuators can operate with the controllers below. Select the controller according to your usage.

Name	External View	Model	Description	Max. Positioning Points	Input Voltage	Power Supply Capacity	Standard Price	See Page
Solenoid Valve Type		AMEC-C-10①-NP-2-1	Easy-to-use controller, even for beginners	3 points	AC100V	2.4A rated	-	→ P477
		ASEP-C-10①-NP-2-0	Operable with same signal as solenoid valve. Supports both single and double solenoid types. No homing necessary with simple absolute type.					
Splash-Proof Solenoid Valve Type		ASEP-CW-10①-NP-2-0						→ P487
Positioner Type		ACON-C-10①-NP-2-0	Positioning is possible for up to 512 points	512 points	DC24V	(Standard) 1.3A rated 4.4A max.	-	
Safety-Compliant Positioner Type		ACON-CG-10①-NP-2-0						
Pulse Train Input Type (Differential Line Driver)		ACON-PL-10①-NP-2-0	Pulse train input type with differential line driver support	(-)	DC24V	(Power-saving) 1.3A rated 2.5A max.	-	→ P535
Pulse Train Input Type (Open Collector)		ACON-PO-10①-NP-2-0	Pulse train input type with open collector support					
Serial Communication Type		ACON-SE-10①-N-0-0	Dedicated to serial communication	64 points				
Field Network Type		RACON-10①	Dedicated to field network	768 points				→ P503
Program Control Type		ASEL-C-1-10①-NP-2-0	Programmed operation is possible. Operation is possible on up to 2 axes	1500 points				→ P567

\* This is for the single-axis ASEL.  
\* ① is a placeholder for the code "LA", if the power-saving option is specified.

- Slider Type
- Mini
- Standard
- Controllers Integrated
- Rod Type
- Mini
- Standard
- Controllers Integrated
- Table/Arm/Flat Type
- Mini
- Standard
- Gripper/Rotary Type
- Linear Servo Type
- Cleanroom Type
- Splash Proof
- Controllers
- PMEC/AMEC
- PSEP/ASEP
- ROBO NET
- ERC2
- PCON
- ACON
- SCON
- PSEL
- ASEL
- SSEL
- XSEL
- Pulse Motor
- Servo Motor (24V)
- Servo Motor (200V)
- Linear Servo Motor

# RCA2-TA5R

ROBO Cylinder Table Type Side-Mounted Motor 55mm Width 24V Servo Motor Ball Screw

■ Configuration: **RCA2** — **TA5R** — **I** — **20** —  —  —  —  —

Series — Type — Encoder — Motor — Lead — Stroke — Compatible Controllers — Cable Length — Option

I: Incremental  
\* The simple absolute encoder is also considered type "I".

20: 20W Servo motor

10 : 10mm  
5 : 5mm  
2.5 : 2.5mm

25: 25mm  
100: 100mm (25mm pitch increments)

A1: ACON  
RACON  
ASEL  
A3: AMEC  
ASEP

N : None  
P : 1m  
S : 3m  
M : 5m  
X   : Custom

See Options below  
\* Be sure to specify which side the motor is to be mounted (ML/MR).

\* See page Pre-35 for an explanation of the naming convention.

Power-saving

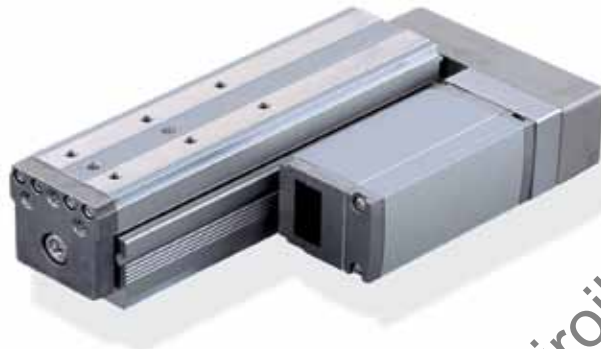

Technical References P. A-5

**POINT**  
Notes on Selection

(1) Please note that the maximum speed is different when used horizontally versus vertically.  
(2) The load capacity is based on operation at an acceleration of 0.3G (0.2G for the 2.5mm-lead model, or when used vertically). This is the upper limit of the acceleration.

Actuator Specifications						Stroke and Maximum Speed	
■ Lead and Load Capacity						25 ~ 100 (25mm increments)	
Model	Motor Output (W)	Lead (mm)	Max. Load Capacity		Rated Thrust (N)	Stroke (mm)	
			Horizontal (kg)	Vertical (kg)			
RCA2-TA5R-I-20-10-①-②-③-④		10	2	1	34	10	465 <400>
RCA2-TA5R-I-20-5-①-②-③-④	20	5	3.5	2	68	5	250
RCA2-TA5R-I-20-2.5-①-②-③-④		2.5	5	3	137	2.5	125

Legend: ① Stroke ② Compatible controller ③ Cable length ④ Options

\* The values enclosed in "<" ">" apply to vertical usage. (Unit: mm/s)

① Stroke List

Stroke (mm)	Standard Price
25	-
50	-
75	-
100	-

③ Cable List

Type	Cable Symbol	Standard Price
Standard Type (Robot Cables)	P (1m)	-
	S (3m)	-
	M (5m)	-
Special Lengths	X06 (6m) ~ X10 (10m)	-
	X11 (11m) ~ X15 (15m)	-
	X16 (16m) ~ X20 (20m)	-

\* The standard cable is the motor-encoder integrated robot cable.  
\* See page A-39 for cables for maintenance.

④ Option List

Name	Option Code	See Page	Standard Price
Brake	B	→ A-25	-
Cable exit direction (Top)	CJT		
Cable exit direction (Outside)	CJO	→ A-25	-
Cable exit direction (Bottom)	CJB		
Power-saving	LA	→ A-32	-
Left-mounted Motor (Standard)	ML	→ A-33	-
Right-mounted motor	MR	→ A-33	-
Reversed-home	NM	→ A-33	-

Actuator Specifications

Item	Description
Drive System	Ball screw ø8mm C10 grade
Positioning Repeatability	±0.02mm
Lost Motion	0.1mm or less
Base	Material: Aluminum (special alumite treated)
Allowable Static Load Moment	Ma: 25.5 N·m Mb: 36.5 N·m Mc: 56.1 N·m
Allowable Dynamic Load Moment	Ma: 6.57 N·m Mb: 9.32 N·m Mc: 14.32 N·m
Overhang Load Length	Within the load moment range
Ambient Operating Temp./Humidity	0~40°C, 85% RH or less (non-condensing)

Directions of Allowable Load Moments

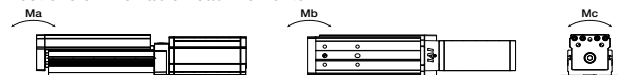

5,000 km service life

Dimensions

CAD drawings can be downloaded from IAI website. [www.intelligentactuator.com](http://www.intelligentactuator.com)



\* Please note that, for 25mm stroke model with brake, the motor unit protrudes from the end of the table.

For Special Orders P. A-9

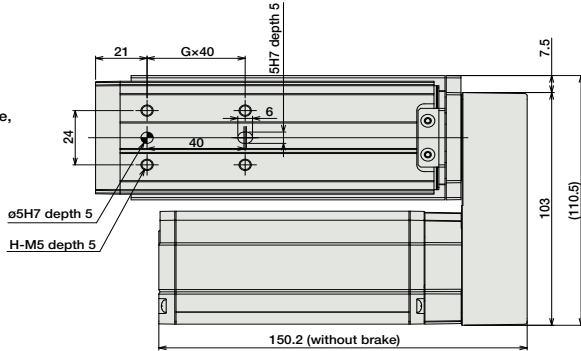
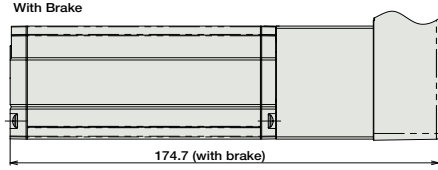

The offset reference position of the moment is the same as TA5C (P304).

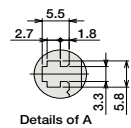
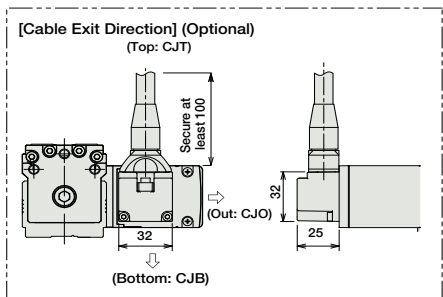
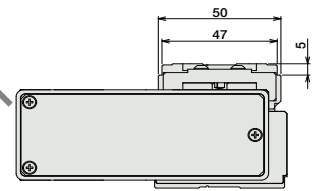
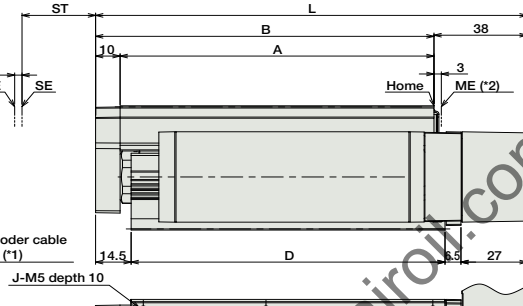
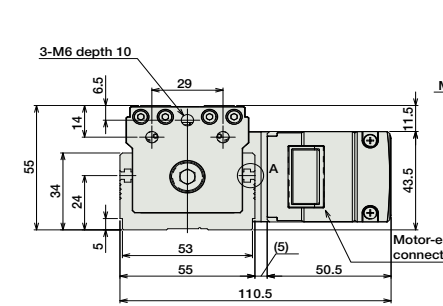

■ Dimensions and Weight by Stroke \* Adding a brake will increase the actuator's weight by 0.3kg.

Stroke	25	50	75	100
L	151	176	201	226
A	103	128	153	178
B	113	138	163	188
D	103	128	153	178
E	1	1	2	2
F	43	68	43	68
G	1	1	2	2
H	4	4	6	6
J	6	6	8	8
Weight (kg)	1.4	1.6	1.7	1.9

(\*1) The motor-encoder cable is connected directly to the motor cover of the actuator. See page A-39 for details on cables.

(\*2) After homing, the slider moves to the ME; therefore, please watch for any interference with the surrounding objects.

ME: Mechanical end  
SE: Stroke end

② Compatible Controllers

The RCA2 series actuators can operate with the controllers below. Select the controller according to your usage.

Name	External View	Model	Description	Max. Positioning Points	Input Voltage	Power Supply Capacity	Standard Price	See Page
Solenoid Valve Type		AMEC-C-20SI①-NP-2-1	Easy-to-use controller, even for beginners	3 points	AC100V	2.4A rated	-	→ P477
		ASEP-C-20SI①-NP-2-0	Operable with same signal as solenoid valve. Supports both single and double solenoid types. No homing necessary with simple absolute type.					
Splash-Proof Solenoid Valve Type		ASEP-CW-20SI①-NP-2-0						
Positioner Type		ACON-C-20SI①-NP-2-0	Positioning is possible for up to 512 points	512 points	DC24V	(Standard) 1.3A rated 4.4A max.	-	-
Safety-Compliant Positioner Type		ACON-CG-20SI①-NP-2-0						
Pulse Train Input Type (Differential Line Driver)		ACON-PL-20SI①-NP-2-0	Pulse train input type with differential line driver support	(-)	DC24V	(Power-saving) 1.3A rated 2.5A max.	-	→ P535
Pulse Train Input Type (Open Collector)		ACON-PO-20SI①-NP-2-0	Pulse train input type with open collector support					
Serial Communication Type		ACON-SE-20SI①-N-0-0	Dedicated to serial communication	64 points				
Field Network Type		RACON-20S①	Dedicated to field network	768 points				→ P503
Program Control Type		ASEL-C-1-20SI①-NP-2-0	Programmed operation is possible. Operation is possible on up to 2 axes	1500 points				→ P567

\* This is for the single-axis ASEL.

\* ① is a placeholder for the code "LA", if the power-saving option is specified.

- Slider Type
- Mini
- Standard
- Controllers Integrated
- Rod Type
- Mini
- Standard
- Controllers Integrated
- Table/Arm/Flat Type
- Mini
- Standard
- Gripper/Rotary Type
- Linear Servo Type
- Cleanroom Type
- Splash Proof
- Controllers
- PMEC/AMEC
- PSEP/ASEP
- ROBO NET
- ERC2
- PCON
- ACON
- SCON
- PSEL
- ASEL
- SSEL
- XSEL
- Pulse Motor
- Servo Motor (24V)
- Servo Motor (200V)
- Linear Servo Motor

# RCA2-TA6R

ROBO Cylinder Table Type Side-Mounted Motor 65mm Width 24V Servo Motor Ball Screw

■ Configuration: **RCA2** — **TA6R** — **I** — **20** —  —  —  —  —

Series — Type — Encoder — Motor — Lead — Stroke — Compatible Controllers — Cable Length — Option

I: Incremental  
\* The simple absolute encoder is also considered type "I".

20: 20W Servo motor

12: 12mm  
6: 6mm  
3: 3mm

25: 25mm  
150: 150mm (25mm pitch increments)

A1: ACON  
RACON  
ASEL  
A3: AMEC  
ASEP

N: None  
P: 1m  
S: 3m  
M: 5m  
X  : Custom

See Options below  
\* Be sure to specify which side the motor is to be mounted (ML/MR).

\* See page Pre-35 for an explanation of the naming convention.

Power-saving



Technical References P. A-5



- Please note that the maximum speed is different when used horizontally versus vertically.
- The load capacity is based on operation at an acceleration of 0.3G (0.2G for the 3mm-lead model, or when used vertically). This is the upper limit of the acceleration.

Actuator Specifications						Stroke and Maximum Speed		
■ Lead and Load Capacity						25 ~ 150 (25mm increments)		
Model	Motor Output (W)	Lead (mm)	Max. Load Capacity		Rated Thrust (N)	Stroke (mm)		
			Horizontal (kg)	Vertical (kg)				
RCA2-TA6R-I-20-12-①-②-③-④		12	2	0.5	17	25~150 (25mm increments)	12	560 <500>
RCA2-TA6R-I-20-6-①-②-③-④	20	6	4	1.5	34		6	300
RCA2-TA6R-I-20-3-①-②-③-④		3	6	3	68		3	150

Legend: ① Stroke ② Compatible controller ③ Cable length ④ Options

\* The values enclosed in "<" ">" apply to vertical usage. (Unit: mm/s)

① Stroke List	
Stroke (mm)	Standard Price
25	-
50	-
75	-
100	-
125	-
150	-

③ Cable List		
Type	Cable Symbol	Standard Price
Standard Type (Robot Cables)	P (1m)	-
	S (3m)	-
	M (5m)	-
Special Lengths	X06 (6m) ~ X10 (10m)	-
	X11 (11m) ~ X15 (15m)	-
	X16 (16m) ~ X20 (20m)	-

\* The standard cable is the motor-encoder integrated robot cable.  
\* See page A-39 for cables for maintenance.

④ Option List			
Name	Option Code	See Page	Standard Price
Brake	B	→ A-25	-
Cable exit direction (Top)	CJT	→ A-25	-
Cable exit direction (Outside)	CJO		
Cable exit direction (Bottom)	CJB		
Power-saving	LA	→ A-32	-
Left-mounted Motor (Standard)	ML	→ A-33	-
Right-mounted motor	MR	→ A-33	-
Reversed-home	NM	→ A-33	-

Actuator Specifications	
Item	Description
Drive System	Ball screw ø10mm C10 grade
Positioning Repeatability	±0.02mm
Lost Motion	0.1mm or less
Base	Material: Aluminum (special alumite treated)
Allowable Static Load Moment	Ma: 29.4 N·m Mb: 42.0 N·m Mc: 74.1 N·m
Allowable Dynamic Load Moment	Ma: 7.26 N·m Mb: 10.3 N·m Mc: 18.25 N·m
Overhang Load Length	Within the load moment range
Ambient Operating Temp./Humidity	0~40°C, 85% RH or less (non-condensing)

Directions of Allowable Load Moments



5,000 km service life

Dimensions

CAD drawings can be downloaded from IAI website. [www.intelligentactuator.com](http://www.intelligentactuator.com)



For Special Orders P. A-9

\* Please note that, for 25mm stroke model with brake, the motor unit protrudes from the end of the table.

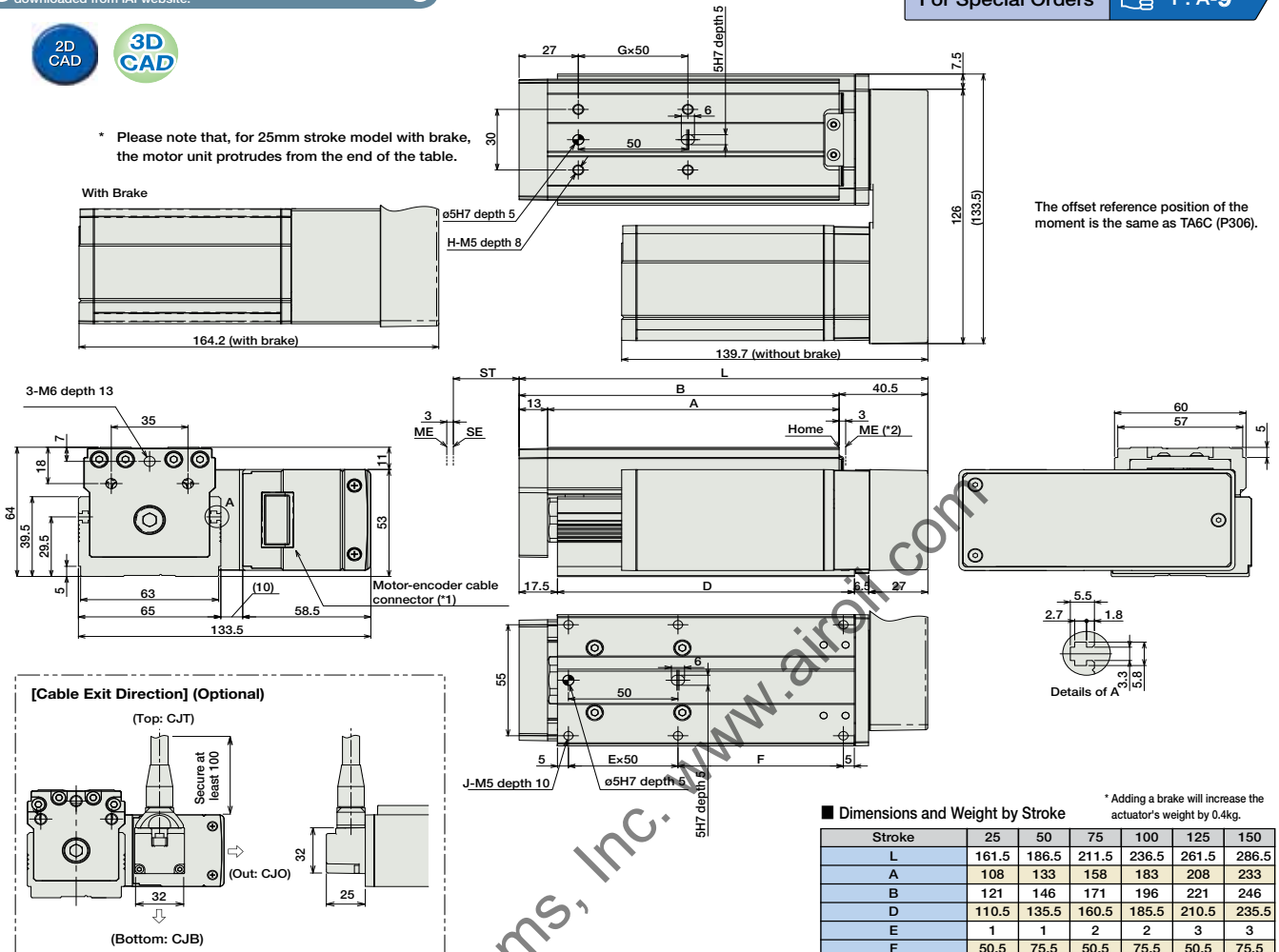

The offset reference position of the moment is the same as TA6C (P306).

■ Dimensions and Weight by Stroke

\* Adding a brake will increase the actuator's weight by 0.4kg.

Stroke	25	50	75	100	125	150
L	161.5	186.5	211.5	236.5	261.5	286.5
A	108	133	158	183	208	233
B	121	146	171	196	221	246
D	110.5	135.5	160.5	185.5	210.5	235.5
E	1	1	2	2	3	3
F	50.5	75.5	50.5	75.5	50.5	75.5
G	1	1	2	2	3	3
H	4	4	6	6	8	8
J	6	6	8	8	10	10
Weight (kg)	2.1	2.3	2.5	2.7	2.9	3.1

(\*1) The motor-encoder cable is connected directly to the motor cover of the actuator. See page A-39 for details on cables.  
 (\*2) After homing, the slider moves to the ME; therefore, please watch for any interference with the surrounding objects.  
 ME: Mechanical end  
 SE: Stroke end

② Compatible Controllers

The RCA2 series actuators can operate with the controllers below. Select the controller according to your usage.

Name	External View	Model	Description	Max. Positioning Points	Input Voltage	Power Supply Capacity	Standard Price	See Page										
Solenoid Valve Type		AMEC-C-20①-NP-2-1	Easy-to-use controller, even for beginners	3 points	AC100V	2.4A rated	-	→ P477										
		ASEP-C-20①-NP-2-0	Operable with same signal as solenoid valve. Supports both single and double solenoid types. No homing necessary with simple absolute type.															
Splash-Proof Solenoid Valve Type		ASEP-CW-20①-NP-2-0									→ P487							
Positioner Type		ACON-C-20①-NP-2-0	Positioning is possible for up to 512 points	512 points					DC24V	(Standard) 1.3A rated 4.4A max.	-							
Safety-Compliant Positioner Type		ACON-CG-20①-NP-2-0																
Pulse Train Input Type (Differential Line Driver)		ACON-PL-20①-NP-2-0	Pulse train input type with differential line driver support	(-)									(Power-saving) 1.3A rated 2.5A max.	-	→ P535			
Pulse Train Input Type (Open Collector)	ACON-PO-20①-NP-2-0	Pulse train input type with open collector support																
Serial Communication Type		ACON-SE-20①-N-0-0	Dedicated to serial communication	64 points														
Field Network Type		RACON-20①	Dedicated to field network	768 points														→ P503
Program Control Type		ASEL-C-1-20①-NP-2-0	Programmed operation is possible. Operation is possible on up to 2 axes	1500 points			→ P567											

\* This is for the single-axis ASEL.  
 \* ① is a placeholder for the code "LA", if the power-saving option is specified.



# RCA2-TA7R

ROBO Cylinder Table Type Side-Mounted Motor 75mm Width 24V Servo Motor Ball Screw

■ Configuration: **RCA2** — **TA7R** — **I** — **30** —  —  —  —  —

Series	Type	Encoder	Motor	Lead	Stroke	Compatible Controllers	Cable Length	Option
		I: Incremental * The simple absolute encoder is also considered type "I".	30: 30W Servo motor	12 : 12mm 6 : 6mm 3 : 3mm	25: 25mm 200: 200mm (25mm pitch increments)	A1: ACON RACON ASEL A3: AMEC ASEP	N : None P : 1m S : 3m M : 5m X <input type="checkbox"/> <input type="checkbox"/> : Custom	See Options below * Be sure to specify which side the motor is to be mounted (ML/MR).

\* See page Pre-35 for an explanation of the naming convention.

Power-saving



Technical References P. A-5

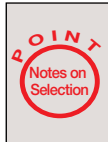

- Please note that the maximum speed is different when used horizontally versus vertically.
- The load capacity is based on operation at an acceleration of 0.3G (0.2G for the 3mm-lead model, or when used vertically). This is the upper limit of the acceleration.

Actuator Specifications

■ Lead and Load Capacity

Model	Motor Output (W)	Lead (mm)	Max. Load Capacity		Rated Thrust (N)	Stroke (mm)
			Horizontal (kg)	Vertical (kg)		
RCA2-TA7R-I-30-12-①-②-③-④	30	12	4	1	26	25~200 (25mm increments)
RCA2-TA7R-I-30-6-①-②-③-④		6	6	2.5	53	
RCA2-TA7R-I-30-3-①-②-③-④		3	8	4	105	

■ Stroke and Maximum Speed

Stroke / Lead	25 ~ 200 (25mm increments)	
	12	600 <580>
6	300	
3	150	

Legend: ① Stroke ② Compatible controller ③ Cable length ④ Options

\* The values enclosed in "<" >" apply to vertical usage. (Unit: mm/s)

① Stroke List

Stroke (mm)	Standard Price
25	-
50	-
75	-
100	-
125	-
150	-
175	-
200	-

③ Cable List

Type	Cable Symbol	Standard Price
Standard Type (Robot Cables)	P (1m)	-
	S (3m)	-
	M (5m)	-
Special Lengths	X06 (6m) ~ X10 (10m)	-
	X11 (11m) ~ X15 (15m)	-
	X16 (16m) ~ X20 (20m)	-
		-

\* The standard cable is the motor-encoder integrated robot cable.  
\* See page A-39 for cables for maintenance.

④ Option List

Name	Option Code	See Page	Standard Price
Brake	B	→ A-25	-
Cable exit direction (Top)	CJT		
Cable exit direction (Outside)	CJO	→ A-25	-
Cable exit direction (Bottom)	CJB		
Power-saving	LA	→ A-32	-
Left-mounted Motor (Standard)	ML	→ A-33	-
Right-mounted motor	MR	→ A-33	-
Reversed-home	NM	→ A-33	-

Actuator Specifications

Item	Description
Drive System	Ball screw ø10mm C10 grade
Positioning Repeatability	±0.02mm
Lost Motion	0.1mm or less
Base	Material: Aluminum (special alumite treated)
Allowable Static Load Moment	Ma: 42.6 N·m Mb: 60.8 N·m Mc: 123.2 N·m
Allowable Dynamic Load Moment	Ma: 9.91 N·m Mb: 14.13 N·m Mc: 28.65 N·m
Overhang Load Length	Within the load moment range
Ambient Operating Temp./Humidity	0~40°C, 85% RH or less (non-condensing)

Directions of Allowable Load Moments

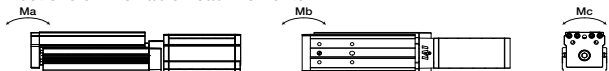

5,000 km service life

Dimensions

CAD drawings can be downloaded from IAI website. [www.intelligentactuator.com](http://www.intelligentactuator.com)



\* Please note that, for 25mm stroke model with brake, the motor unit protrudes from the end of the table.

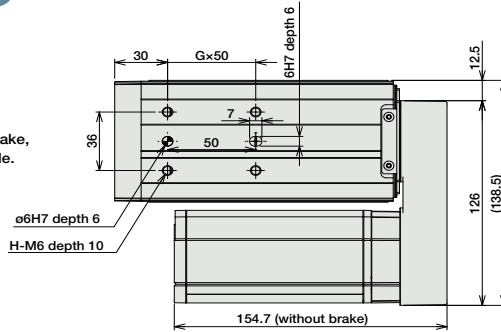
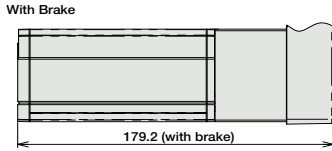

The offset reference position of the moment is the same as TA7C (P308).

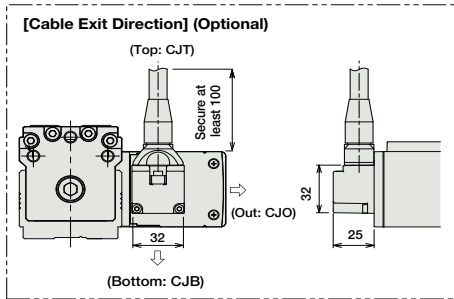
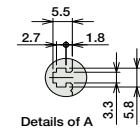
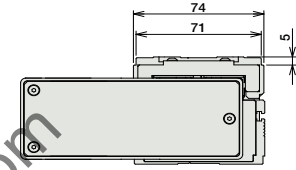
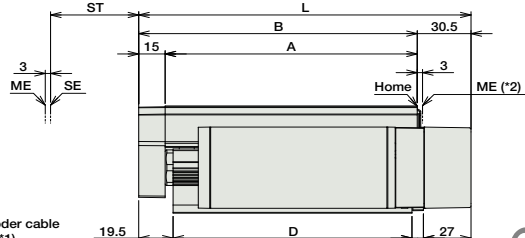
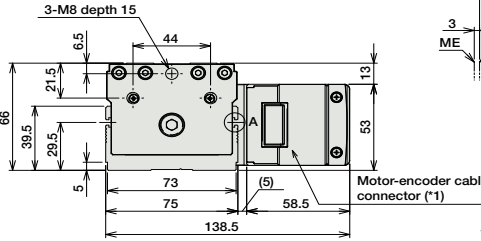

(\*1) The motor-encoder cable is connected directly to the motor cover of the actuator. See page A-39 for details on cables.  
 (\*2) After homing, the slider moves to the ME; therefore, please watch for any interference with the surrounding objects.  
 ME: Mechanical end  
 SE: Stroke end

■ Dimensions and Weight by Stroke

\* Adding a brake will increase the actuator's weight by 0.4kg.

Stroke	25	50	75	100	125	150	175	200
L	163.5	188.5	213.5	238.5	263.5	288.5	313.5	338.5
A	118	143	168	193	218	243	268	293
B	133	158	183	208	233	258	283	308
D	110.5	135.5	160.5	185.5	210.5	235.5	260.5	285.5
E	1	1	2	2	3	3	4	4
F	50.5	75.5	50.5	75.5	50.5	75.5	50.5	75.5
G	1	1	2	2	3	3	4	4
H	4	4	6	6	8	8	10	10
J	6	6	8	8	10	10	12	12
Weight (kg)	2.4	2.6	2.8	3.1	3.3	3.5	3.7	3.9

② Compatible Controllers

The RCA2 series actuators can operate with the controllers below. Select the controller according to your usage.

Name	External View	Model	Description	Max. Positioning Points	Input Voltage	Power Supply Capacity	Standard Price	See Page
Solenoid Valve Type		AMEC-C-30①-NP-2-1	Easy-to-use controller, even for beginners	3 points	AC100V	2.4A rated	-	→ P477
		ASEP-C-30①-NP-2-0	Operable with same signal as solenoid valve. Supports both single and double solenoid types. No homing necessary with simple absolute type.					→ P487
Splash-Proof Solenoid Valve Type		ASEP-CW-30①-NP-2-0						
Positioner Type		ACON-C-30①-NP-2-0	Positioning is possible for up to 512 points	512 points	DC24V	(Standard) 1.3A rated 4.0A max.	-	
Safety-Compliant Positioner Type		ACON-CG-30①-NP-2-0						
Pulse Train Input Type (Differential Line Driver)		ACON-PL-30①-NP-2-0	Pulse train input type with differential line driver support	(-)	DC24V	(Power-saving) 1.3A rated 2.2A max.	-	→ P535
Pulse Train Input Type (Open Collector)		ACON-PO-30①-NP-2-0	Pulse train input type with open collector support					
Serial Communication Type		ACON-SE-30①-N-0-0	Dedicated to serial communication	64 points				
Field Network Type		RACON-30①	Dedicated to field network	768 points				→ P503
Program Control Type		ASEL-C-1-30①-NP-2-0	Programmed operation is possible. Operation is possible on up to 2 axes	1500 points				→ P567

\* This is for the single-axis ASEL.  
 \* ① is a placeholder for the code "LA", if the power-saving option is specified.

# RCA-A4R

ROBO Cylinder Arm Type Side-Mounted Motor 40mm Width 24V Servo Motor Ball Screw

■ Configuration: **RCA** — **A4R** —  — **20** —  —  —  —  —

Series — Type — Encoder — Motor — Lead — Stroke — Compatible Controllers — Cable Length — Option

I : Incremental  
A : Absolute

20 : 20W servo motor  
\* ASEL can only be used as the absolute encoder. Simple absolute encoders are considered incremental.

10 : 10mm  
5 : 5mm

50 : 50mm  
200 : 200mm (50mm pitch increments)

A1: ACON  
RACON  
ASEL  
A3: AMEC  
ASEP

N : None  
P : 1m  
S : 3m  
M : 5m  
X  : Custom  
R  : Robot cable

See Options below  
\* Be sure to specify which side the motor is to be mounted (ML/MR).

\* See page Pre-35 for an explanation of the naming convention.

Power-saving

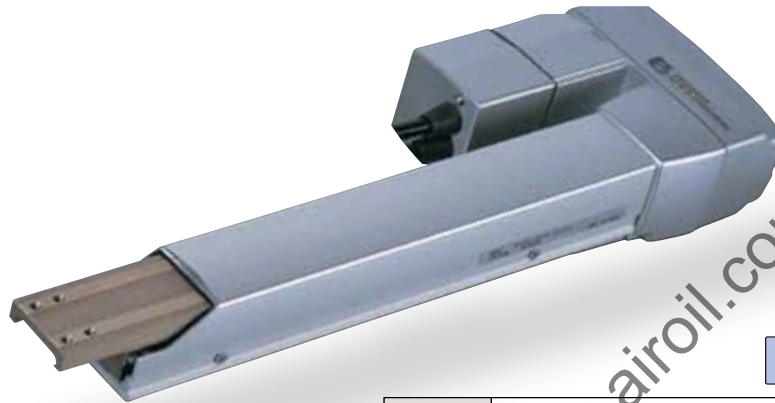

Technical References P. A-5

**POINT**  
Notes on Selection

(1) When the stroke increases, the maximum speed will drop to prevent the ball screw from reaching the critical rotational speed. Use the actuator specification table below to check the maximum speed at the stroke you desire.

(2) The load capacity is based on operation at an acceleration of 0.2G. This is the upper limit of the acceleration.

## Actuator Specifications

### Lead and Load Capacity

Model	Motor Output (W)	Lead (mm)	Max. Load Capacity		Rated Thrust (N)	Stroke (mm)
			Horizontal (kg)	Vertical (kg)		
RCA-A4R-①-20-10-②-③-④-B-⑤	20	10	-	2.5	39.2	50~200 (50mm increments)
RCA-A4R-①-20-5-②-③-④-B-⑤		5	-	4.5	78.4	

Legend: ① Encoder ② Stroke ③ Compatible controller ④ Cable length ⑤ Options

### Stroke and Maximum Speed

Stroke Lead	50 ~ 200 (50mm increments)	
	10	330
5	165	

(Unit: mm/s)

## Encoder & Stroke List

② Stroke (mm)	Standard Price	
	① Encoder	
	Incremental	Absolute
50	-	-
100	-	-
150	-	-
200	-	-

## ④ Cable List

Type	Cable Symbol	Standard Price
Standard Type	P (1m)	-
	S (3m)	-
	M (5m)	-
Special Lengths	X06 (6m) ~ X10 (10m)	-
	X11 (11m) ~ X15 (15m)	-
	X16 (16m) ~ X20 (20m)	-
	-	-
Robot Cable	R01 (1m) ~ R03 (3m)	-
	R04 (4m) ~ R05 (5m)	-
	R06 (6m) ~ R10 (10m)	-
	R11 (11m) ~ R15 (15m)	-
	R16 (16m) ~ R20 (20m)	-
	-	-

\* See page A-39 for cables for maintenance.

## ⑤ Option List

Name	Option Code	See Page	Standard Price
Brake (standard)	B	→ A-25	-
Power-saving	LA	→ A-32	
Bottom-mounted motor	MB	→ A-33	
Right-mounted motor	MR	→ A-33	
Left-mounted motor	ML	→ A-33	
Reversed-home	NM	→ A-33	

## Actuator Specifications

Item	Description
Drive System	Ball screw ø6mm C10 grade (ball screw speed reduced by 1/2 by timing belt)
Positioning Repeatability	±0.02mm
Lost Motion	0.1mm or less
Base	Material: Aluminum (white alumite treated)
Allowable Load Moment	Ma: 2.7 N·m Mb: 3.1 N·m Mc: 2.9 N·m
Ambient Operating Temp./Humidity	0~40°C, 85% RH or less (non-condensing)

Directions of Allowable Load Moments

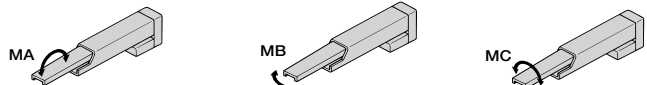

5,000 km service life

Dimensions

CAD drawings can be downloaded from IAI website. [www.intelligentactuator.com](http://www.intelligentactuator.com)

For Special Orders P. A-9



- \*1 The motor-encoder cable is connected here. See page A-39 for details on cables.
- \*2 When homing, the rod moves to the ME; therefore, please watch for any interference with the surrounding objects.  
ME: Mechanical end SE: Stroke end

Bottom-mounted motor (option code: MB)

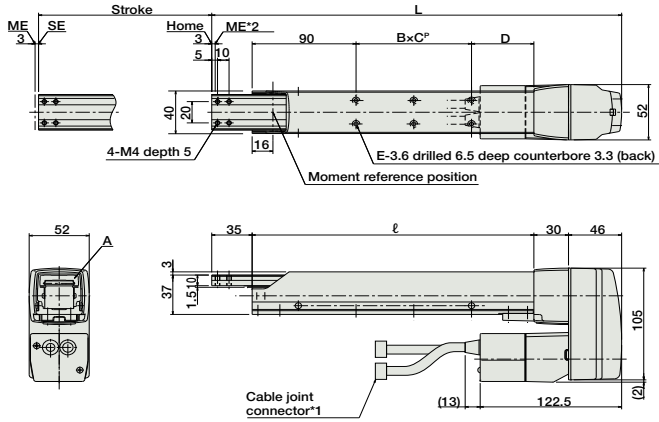

Right-mounted motor (option code: MR)

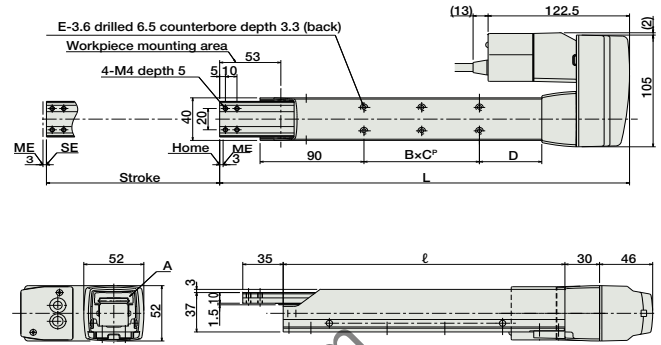

Left-mounted motor (option code: ML)

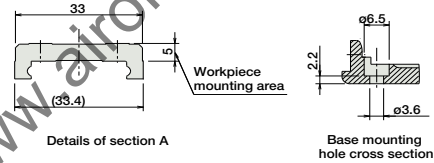
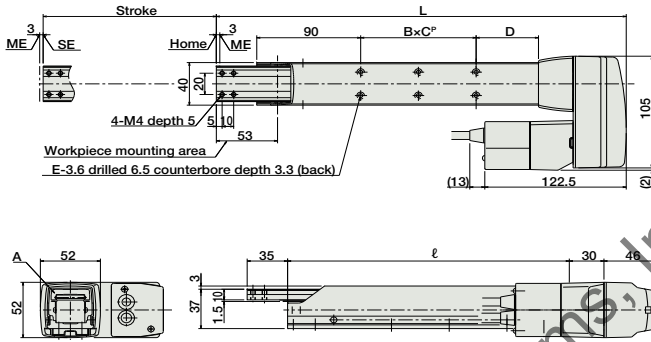

■ Dimensions and Weight by Stroke

Stroke	50	100	150	200
L	255	305	355	405
ℓ	144	194	244	294
BxC*	1x19	1x50	2x50	2x50
D	35	54	54	104
E	4	4	6	6
Weight (kg)	1.7	1.8	2.0	2.1

③ Compatible Controllers

The RCA series actuators can operate with the controllers below. Select the controller according to your usage.

Name	External View	Model	Description	Max. Positioning Points	Input Voltage	Power Supply Capacity	Standard Price	See Page
Solenoid Valve Type		AMEC-C-20I②-NP-2-1	Easy-to-use controller, even for beginners	3 points	AC100V	2.4A rated	-	→ P477
		ASEP-C-20I②-NP-2-0	Operable with same signal as solenoid valve. Supports both single and double solenoid types. No homing necessary with simple absolute type.				-	→ P487
Splash-Proof Solenoid Valve Type		ASEP-CW-20I②-NP-2-0					-	
Positioner Type		ACON-C-20I②-NP-2-0	Positioning is possible for up to 512 points	512 points	DC24V	1.3A rated 4.4A peak	-	
Safety-Compliant Positioner Type		ACON-CG-20I②-NP-2-0		-				
Pulse Train Input Type (Differential Line Driver)		ACON-PL-20I②-NP-2-0	Pulse train input type with differential line driver support	(-)	DC24V	1.3A rated 4.4A peak	-	→ P535
Pulse Train Input Type (Open Collector)		ACON-PO-20I②-NP-2-0	Pulse train input type with open collector support				-	
Serial Communication Type		ACON-SE-20I②-N-0-0	Dedicated to serial communication	64 points			-	
Field Network Type		RACON-20②	Dedicated to field network	768 points			-	→ P503
Program Control Type		ASEL-C-1-20①②-NP-2-0	Programmed operation is possible. Operation is possible on up to 2 axes	1500 points			-	→ P567

\* This is for the single-axis ASEL.  
 \* ① is a placeholder for the encoder type (I: incremental, A: absolute).  
 \* ② is a placeholder for the code "LA", if the power-saving option is specified.

- Slider Type
- Mini
- Standard
- Controllers Integrated
- Rod Type
- Mini
- Standard
- Controllers Integrated
- Table/Arm/Flat Type
- Mini
- Standard
- Gripper/Rotary Type
- Linear Servo Type
- Cleanroom Type
- Splash Proof
- Controllers
- PMEC/AMEC
- PSEP/ASEP
- ROBO NET
- ERC2
- PCON
- ACON
- SCON
- PSEL
- ASEL
- SSEL
- XSEL
- Pulse Motor
- Servo Motor (24V)
- Servo Motor (200V)
- Linear Servo Motor

# RCA-A5R

ROBO Cylinder Arm Type Side-Mounted Motor 52mm Width 24V Servo Motor Ball Screw

■ Configuration: **RCA** — **A5R** —  — **20** —  —  —  —  —

Series — Type — Encoder — Motor — Lead — Stroke — Compatible Controllers — Cable Length — Option

I : Incremental  
A : Absolute

20 : 20W servo motor

12 : 12mm  
6 : 6mm

50 : 50mm  
200 : 200mm (50mm pitch increments)

A1 : ACON  
RACON  
ASEL  
A3 : AMEC  
ASEP

N : None  
P : 1m  
S : 3m  
M : 5m  
X  : Custom  
R  : Robot cable

See Options below  
\* Be sure to specify which side the motor is to be mounted (ML/MR).

\* See page Pre-35 for an explanation of the naming convention.

Power-saving

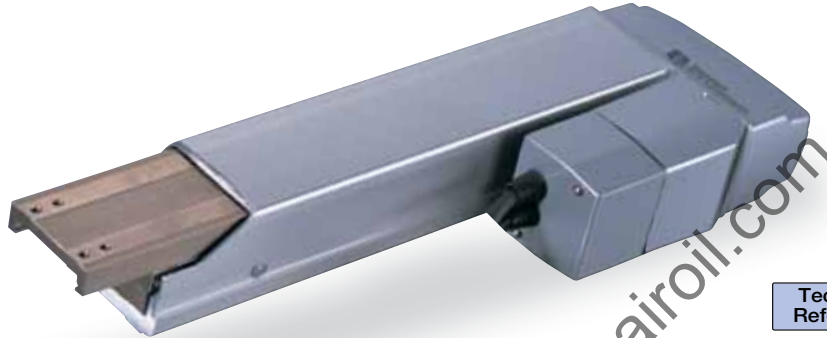

Technical References P. A-5

**POINT**  
Notes on Selection

(1) When the stroke increases, the maximum speed will drop to prevent the ball screw from reaching the critical rotational speed. Use the actuator specification table below to check the maximum speed at the stroke you desire.

(2) The load capacity is based on operation at an acceleration of 0.2G. This is the upper limit of the acceleration.

### Actuator Specifications

#### ■ Lead and Load Capacity

Model	Motor Output (W)	Lead (mm)	Max. Load Capacity		Rated Thrust (N)	Stroke (mm)
			Horizontal (kg)	Vertical (kg)		
RCA-A5R-①-20-12-②-③-④-B-⑤	20	12	-	2	33.3	50~200 (50mm increments)
RCA-A5R-①-20-6-②-③-④-B-⑤		6	-	4		

Legend: ① Encoder ② Stroke ③ Compatible controller ④ Cable length ⑤ Options

#### ■ Stroke and Maximum Speed

Stroke Lead	50 ~ 200 (50mm increments)	
	12	400
6	200	

(Unit: mm/s)

### Encoder & Stroke List

② Stroke (mm)	Standard Price	
	① Encoder	
	Incremental	Absolute
50	-	-
100	-	-
150	-	-
200	-	-

### ④ Cable List

Type	Cable Symbol	Standard Price
Standard Type	P (1m)	-
	S (3m)	-
	M (5m)	-
Special Lengths	X06 (6m) ~ X10 (10m)	-
	X11 (11m) ~ X15 (15m)	-
	X16 (16m) ~ X20 (20m)	-
Robot Cable	R01 (1m) ~ R03 (3m)	-
	R04 (4m) ~ R05 (5m)	-
	R06 (6m) ~ R10 (10m)	-
	R11 (11m) ~ R15 (15m)	-
	R16 (16m) ~ R20 (20m)	-

\* See page A-39 for cables for maintenance.

### ⑤ Option List

Name	Option Code	See Page	Standard Price
Brake (standard)	B	→ A-25	-
Power-saving	LA	→ A-32	
Bottom-mounted motor	MB	→ A-33	
Right-mounted motor	MR	→ A-33	
Left-mounted motor	ML	→ A-33	
Reversed-home	NM	→ A-33	

### Actuator Specifications

Item	Description
Drive System	Ball screw ø8mm C10 grade (ball screw speed reduced by 1/2 by timing belt)
Positioning Repeatability	±0.02mm
Lost Motion	0.1mm or less
Base	Material: Aluminum (white alumite treated)
Allowable Load Moment	Ma: 4.5 N·m Mb: 5.4 N·m Mc: 4.1 N·m
Ambient Operating Temp./Humidity	0~40°C, 85% RH or less (non-condensing)

Directions of Allowable Load Moments

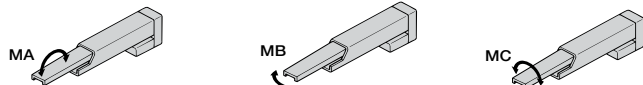

5,000 km service life

Dimensions

CAD drawings can be downloaded from IAI website. [www.intelligentactuator.com](http://www.intelligentactuator.com)

For Special Orders P. A-9



- \*1 The motor-encoder cable is connected here. See page A-39 for details on cables.
  - \*2 When homing, the rod moves to the ME; therefore, please watch for any interference with the surrounding objects.
- ME: Mechanical end SE: Stroke end

Bottom-mounted motor (option code: MB)

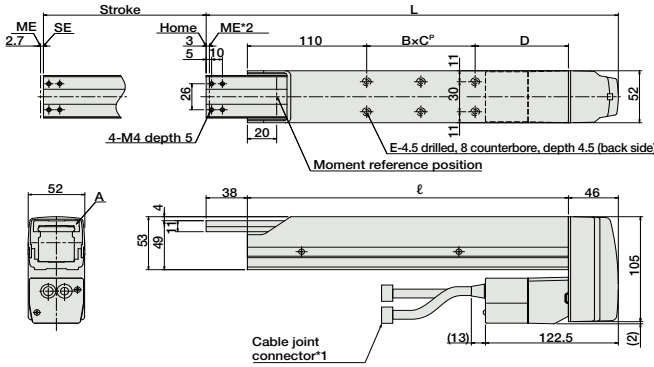

Right-mounted motor (option code: MR)

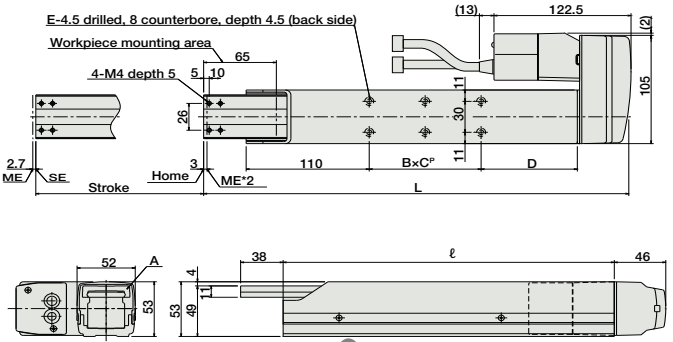

Left-mounted motor (option code: ML)

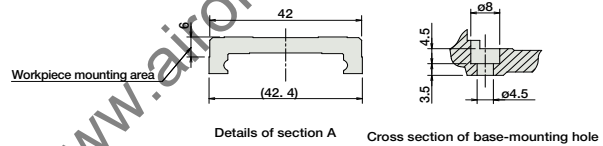
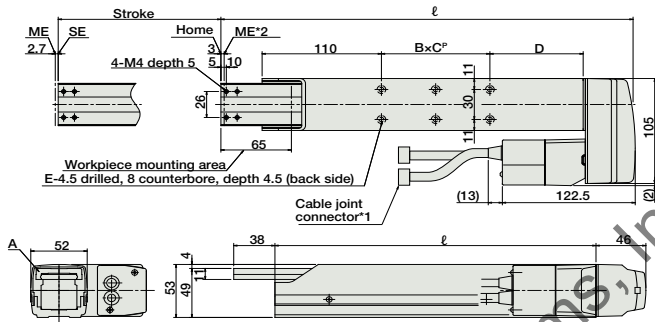

■ Dimensions and Weight by Stroke

Stroke	50	100	150	200
L	280	330	380	430
ℓ	196	246	296	346
BxC*	1x30	1x50	2x50	2x50
D	56	86	86	136
E	4	4	6	6
Weight (kg)	2.2	2.4	2.6	2.8

Note: The 50mm stroke model is only available with a right- or left-mounted motor. Please note that there is no 50mm stroke configuration for the standard model.

③ Compatible Controllers

The RCA series actuators can operate with the controllers below. Select the controller according to your usage.

Name	External View	Model	Description	Max. Positioning Points	Input Voltage	Power Supply Capacity	Standard Price	See Page
Solenoid Valve Type		AMEC-C-20I②-NP-2-1	Easy-to-use controller, even for beginners	3 points	AC100V	2.4A rated	-	→ P477
		ASEP-C-20I②-NP-2-0	Operable with same signal as solenoid valve. Supports both single and double solenoid types. No homing necessary with simple absolute type.					
Splash-Proof Solenoid Valve Type		ASEP-CW-20I②-NP-2-0						→ P487
Positioner Type		ACON-C-20I②-NP-2-0	Positioning is possible for up to 512 points	512 points	DC24V	1.3A rated 4.4A peak	-	→ P535
Safety-Compliant Positioner Type		ACON-CG-20I②-NP-2-0						
Pulse Train Input Type (Differential Line Driver)		ACON-PL-20I②-NP-2-0	Pulse train input type with differential line driver support	(-)	DC24V	1.3A rated 4.4A peak	-	→ P535
Pulse Train Input Type (Open Collector)		ACON-PO-20I②-NP-2-0	Pulse train input type with open collector support					
Serial Communication Type		ACON-SE-20I②-N-0-0	Dedicated to serial communication	64 points				
Field Network Type		RACON-20②	Dedicated to field network	768 points				→ P503
Program Control Type		ASEL-C-1-20I①②-NP-2-0	Programmed operation is possible. Operation is possible on up to 2 axes	1500 points				→ P567

\* This is for the single-axis ASEL.  
 \* ① is a placeholder for the encoder type (I: incremental, A: absolute).  
 \* ② is a placeholder for the code "LA", if the power-saving option is specified.

- Slider Type
- Mini
- Standard
- Controllers Integrated
- Rod Type
- Mini
- Standard
- Controllers Integrated
- Table/Arm/Flat Type
- Mini
- Standard
- Gripper/Rotary Type
- Linear Servo Type
- Cleanroom Type
- Splash Proof
- Controllers
- PMEC/AMEC
- PSEP/ASEP
- ROBO NET
- ERC2
- PCON
- ACON
- SCON
- PSEL
- ASEL
- SSEL
- XSEL
- Pulse Motor
- Servo Motor (24V)
- Servo Motor (200V)
- Linear Servo Motor

# RCA-A6R

ROBO Cylinder Arm Type Side-Mounted Motor 58mm Width 24V Servo Motor Ball Screw

■ Configuration: **RCA** — **A6R** —  — **30** —  —  —  —  —

Series — Type — Encoder — Motor — Lead — Stroke — Compatible Controllers — Cable Length — Option

I : Incremental  
A : Absolute

30 : 30W servo motor  
12 : 12mm  
6 : 6mm

50: 50mm  
200: 200mm (50mm pitch increments)

A1: ACON  
RACON  
ASEL  
A3: AMEC  
ASEP

N : None  
P : 1m  
S : 3m  
M : 5m  
X  : Custom  
R  : Robot cable

See Options below  
\* Be sure to specify which side the motor is to be mounted (ML/MR).

\* See page Pre-35 for an explanation of the naming convention.

Power-saving

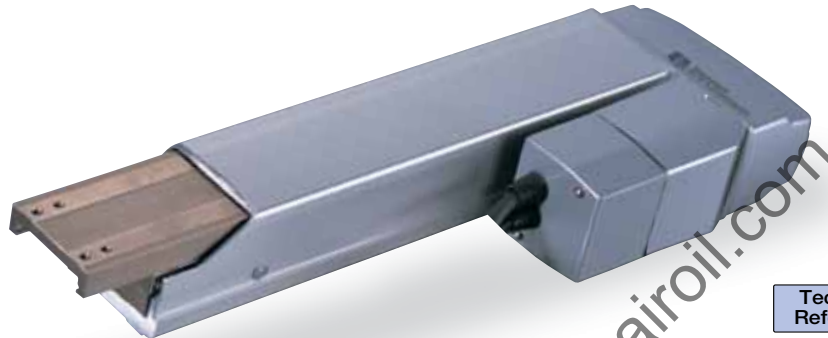

Technical References P. A-5

**POINT**  
Notes on Selection

(1) When the stroke increases, the maximum speed will drop to prevent the ball screw from reaching the critical rotational speed. Use the actuator specification table below to check the maximum speed at the stroke you desire.

(2) The load capacity is based on operation at an acceleration of 0.2G. This is the upper limit of the acceleration.

### Actuator Specifications

#### Lead and Load Capacity

Model	Motor Output (W)	Lead (mm)	Max. Load Capacity		Rated Thrust (N)	Stroke (mm)
			Horizontal (kg)	Vertical (kg)		
RCA-A6R-①-30-12-②-③-④-B-⑤	30	12	-	3	48.4	50~200 (50mm increments)
RCA-A6R-①-30-6-②-③-④-B-⑤		6	-	6	96.8	

Legend: ① Encoder ② Stroke ③ Compatible controller ④ Cable length ⑤ Options

#### Stroke and Maximum Speed

Stroke Lead	50 ~ 200 (50mm increments)	
	12	400
6	200	

(Unit: mm/s)

#### Encoder & Stroke List

② Stroke (mm)	Standard Price	
	① Encoder	
	Incremental	Absolute
50	-	-
100	-	-
150	-	-
200	-	-

#### ④ Cable List

Type	Cable Symbol	Standard Price
Standard Type	P (1m)	-
	S (3m)	-
	M (5m)	-
Special Lengths	X06 (6m) ~ X10 (10m)	-
	X11 (11m) ~ X15 (15m)	-
	X16 (16m) ~ X20 (20m)	-
Robot Cable	R01 (1m) ~ R03 (3m)	-
	R04 (4m) ~ R05 (5m)	-
	R06 (6m) ~ R10 (10m)	-
	R11 (11m) ~ R15 (15m)	-
	R16 (16m) ~ R20 (20m)	-

\* See page A-39 for cables for maintenance.

#### ⑤ Option List

Name	Option Code	See Page	Standard Price
Brake (standard)	B	→ A-25	-
Power-saving	LA	→ A-32	
Bottom-mounted motor	MB	→ A-33	
Right-mounted motor	MR	→ A-33	
Left-mounted motor	ML	→ A-33	
Reversed-home	NM	→ A-33	

#### Actuator Specifications

Item	Description
Drive System	Ball screw ø10mm C10 grade (ball screw speed reduced by 1/2 by timing belt)
Positioning Repeatability	±0.02mm
Lost Motion	0.1mm or less
Base	Material: Aluminum (white alumite treated)
Allowable Load Moment	Ma: 8.1 N·m Mb: 10.0 N·m Mc: 6.5 N·m
Ambient Operating Temp./Humidity	0~40°C, 85% RH or less (non-condensing)

Directions of Allowable Load Moments

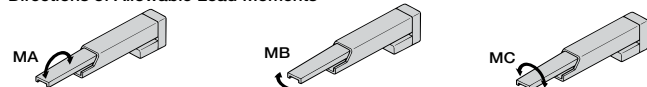

5,000 km service life

Dimensions

CAD drawings can be downloaded from IAI website. [www.intelligentactuator.com](http://www.intelligentactuator.com)

For Special Orders P. A-9



- \*1 The motor-encoder cable is connected here. See page A-39 for details on cables.
- \*2 When homing, the rod moves to the ME; therefore, please watch for any interference with the surrounding objects.  
ME: Mechanical end SE: Stroke end

Bottom-mounted motor (option code: MB)

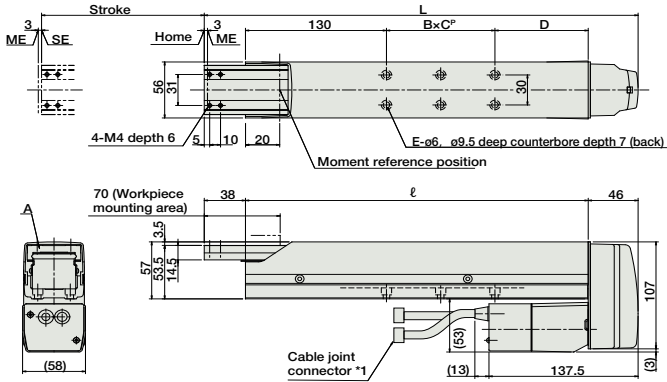

Right-mounted motor (option code: MR)

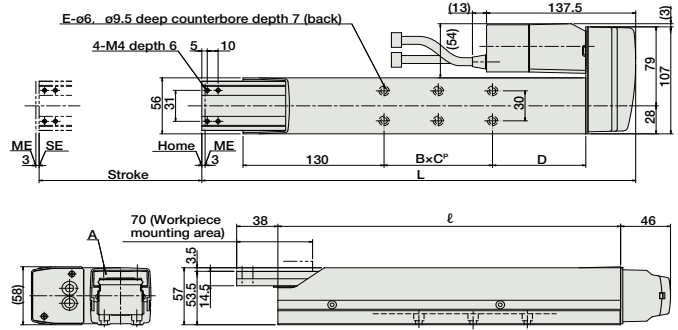

Left-mounted motor (option code: ML)

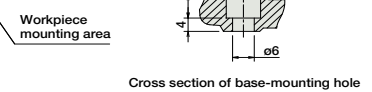
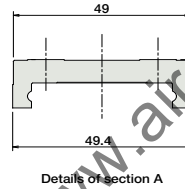
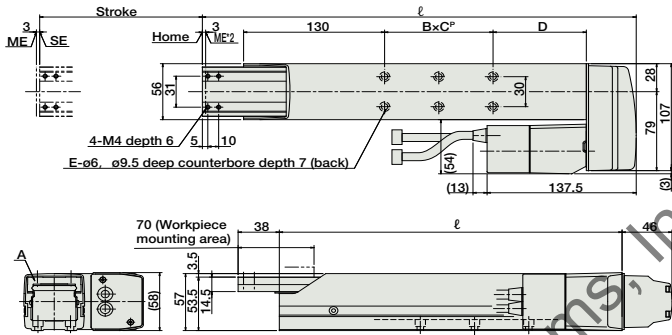

Dimensions and Weight by Stroke

Stroke	50	100	150	200
L	300	350	400	450
l	216	266	316	366
BxC*	1x30	1x50	2x50	2x50
D	56	86	86	136
E	4	4	6	6
Weight (kg)	3.0	3.3	3.6	3.9

Note: The 50mm stroke model is only available with a right- or left-mounted motor. Please note that there is no 50mm stroke configuration for the standard model.

Compatible Controllers

The RCA series actuators can operate with the controllers below. Select the controller according to your usage.

Name	External View	Model	Description	Max. Positioning Points	Input Voltage	Power Supply Capacity	Standard Price	See Page
Solenoid Valve Type		AMEC-C-30I②-NP-2-1	Easy-to-use controller, even for beginners	3 points	AC100V	2.4A rated	-	→ P477
Splash-Proof Solenoid Valve Type		ASEP-C-30I②-NP-2-0	Operable with same signal as solenoid valve. Supports both single and double solenoid types. No homing necessary with simple absolute type.				-	→ P487
Positioner Type		ACON-C-30I②-NP-2-0	Positioning is possible for up to 512 points	512 points	DC24V	1.3A rated 4.4A peak	-	→ P535
Safety-Compliant Positioner Type		ACON-CG-30I②-NP-2-0					-	
Pulse Train Input Type (Differential Line Driver)		ACON-PL-30I②-NP-2-0	Pulse train input type with differential line driver support	(-)	DC24V	1.3A rated 4.4A peak	-	→ P535
Pulse Train Input Type (Open Collector)		ACON-PO-30I②-NP-2-0	Pulse train input type with open collector support				-	
Serial Communication Type		ACON-SE-30I②-N-0-0	Dedicated to serial communication	64 points	-	-	-	-
Field Network Type		RACON-30②	Dedicated to field network	768 points	-	-	-	→ P503
Program Control Type		ASEL-C-1-30I①②-NP-2-0	Programmed operation is possible. Operation is possible on up to 2 axes	1500 points	-	-	-	→ P567

\* This is for the single-axis ASEL.  
 \* ① is a placeholder for the encoder type (I: incremental, A: absolute).  
 \* ② is a placeholder for the code "LA", if the power-saving option is specified.

- Slider Type
- Mini
- Standard
- Controllers Integrated
- Rod Type
- Mini
- Standard
- Controllers Integrated
- Table/Arm/Flat Type
- Mini
- Standard
- Gripper/Rotary Type
- Linear Servo Type
- Cleanroom Type
- Splash Proof
- Controllers
- PMEC/AMEC
- PSEP/ASEP
- ROBO NET
- ERC2
- PCON
- ACON
- SCON
- PSEL
- ASEL
- SSEL
- XSEL
- Pulse Motor
- Servo Motor (24V)
- Servo Motor (200V)
- Linear Servo Motor



# RCS2-A4R

ROBO Cylinder Arm Type Side-Mounted Motor 40mm Width 200V Servo Motor Ball Screw

■ Configuration: **RCS2** — **A4R** —  — **20** —  —  —  —  —

Series — Type — Encoder — Motor — Lead — Stroke — Compatible Controllers — Cable Length — Option

I : Incremental  
A : Absolute

20 : 20W Servo motor

10 : 10mm  
5 : 5mm

50 : 50mm  
200 : 200mm (50mm pitch increments)

T1: XSEL-J/K  
T2: SCON  
SSEL  
XSEL-P/Q

N : None  
P : 1m  
S : 3m  
M : 5m  
X  : Custom  
R  : Robot cable

See Options below  
\* Be sure to specify which side the motor is to be mounted (ML/MR).

\* See page Pre-35 for an explanation of the naming convention.

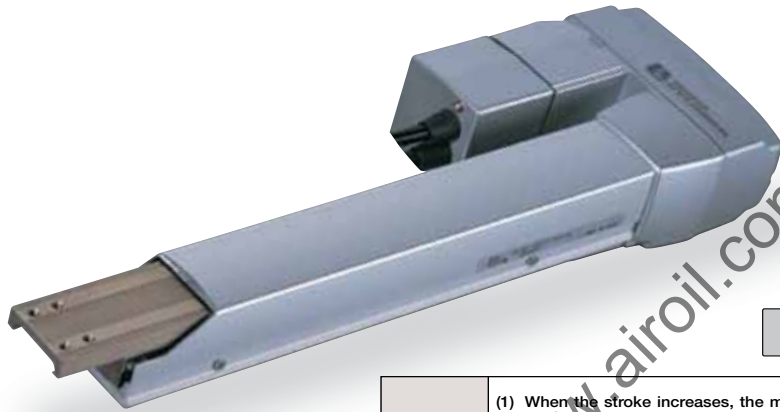

Technical References P. A-5

- POINT**  
Notes on Selection
- When the stroke increases, the maximum speed will drop to prevent the ball screw from reaching the critical rotational speed. Use the actuator specification table below to check the maximum speed at the stroke you desire.
  - The load capacity is based on operation at an acceleration of 0.2G. This is the upper limit of the acceleration.

**Actuator Specifications**

■ Lead and Load Capacity

Model	Motor Output (W)	Lead (mm)	Max. Load Capacity		Rated Thrust (N)	Stroke (mm)
			Horizontal (kg)	Vertical (kg)		
RCS2-A4R-①-20-10-②-③-④-B-⑤	20	10	-	2.5	39.2	50~200 (50mm increments)
RCS2-A4R-①-20-5-②-③-④-B-⑤		5	-	4.5	78.4	

Legend: ① Encoder ② Stroke ③ Compatible controller ④ Cable length ⑤ Options (Unit: mm/s)

■ Stroke and Maximum Speed

Stroke Lead	50 ~ 200 (50mm increments)	
	10	330
5	165	

**Encoder & Stroke List**

② Stroke (mm)	Standard Price	
	① Encoder	
	Incremental	Absolute
50	-	-
100	-	-
150	-	-
200	-	-

**④ Cable List**

Type	Cable Symbol	Standard Price
Standard Type	P (1m)	-
	S (3m)	-
	M (5m)	-
Special Lengths	X06 (6m) ~ X10 (10m)	-
	X11 (11m) ~ X15 (15m)	-
	X16 (16m) ~ X20 (20m)	-
Robot Cable	R01 (1m) ~ R03 (3m)	-
	R04 (4m) ~ R05 (5m)	-
	R06 (6m) ~ R10 (10m)	-
	R11 (11m) ~ R15 (15m)	-
	R16 (16m) ~ R20 (20m)	-

\* See page A-39 for cables for maintenance.

**⑤ Option List**

Name	Option Code	See Page	Standard Price
Brake (standard)	B	→ A-25	-
Bottom-mounted motor	MB	→ A-33	
Right-mounted motor	MR	→ A-33	
Left-mounted motor	ML	→ A-33	
Reversed-home	NM	→ A-33	

**Actuator Specifications**

Item	Description
Drive System	Ball screw ø8mm C10 grade (ball screw speed reduced by 1/2 by timing belt)
Positioning Repeatability	±0.02mm
Lost Motion	0.1mm or less
Base	Material: Aluminum (white alumite treated)
Allowable Load Moment	Ma: 2.7 N·m Mb: 3.1 N·m Mc: 2.9 N·m
Ambient Operating Temp./Humidity	0~40°C, 85% RH or less (non-condensing)

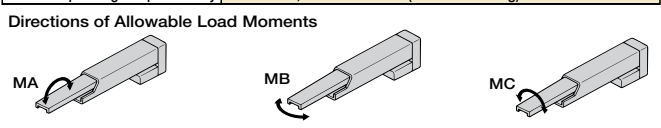

Dimensions

CAD drawings can be downloaded from IAI website. [www.intelligentactuator.com](http://www.intelligentactuator.com)

For Special Orders P. A-9



- \*1 The motor-encoder cable is connected here. See page A-39 for details on cables.
  - \*2 When homing, the rod moves to the ME; therefore, please watch for any interference with the surrounding objects.
- ME: Mechanical end SE: Stroke end

Bottom-mounted motor (option code: MB)

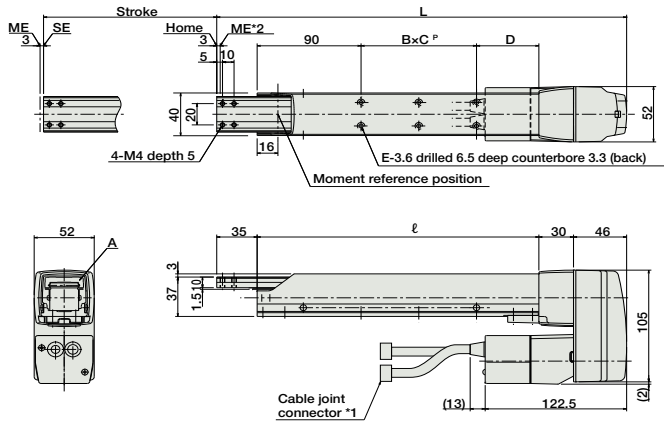

Right-mounted motor (option code: MR)

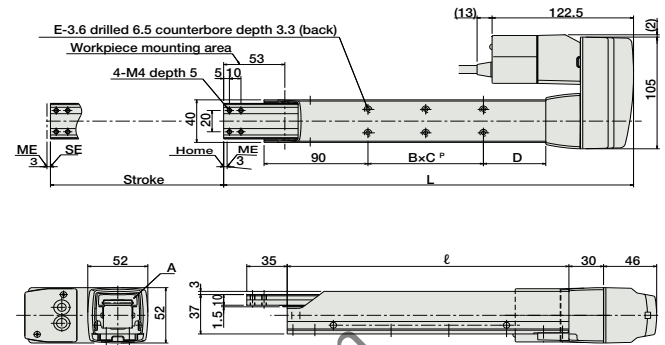

Left-mounted motor (option code: ML)

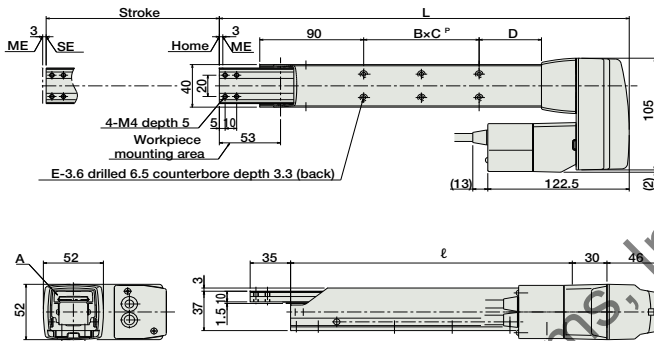

■ Dimensions and Weight by Stroke

Stroke	50	100	150	200
L	255	305	355	405
ℓ	144	194	244	294
BxC*	1x19	1x50	2x50	2x50
D	35	54	54	104
E	4	4	6	6
Weight (kg)	1.7	1.8	2.0	2.1

③ Compatible Controllers

The RCS2 series actuators can operate with the controllers below. Select the controller according to your usage.

Name	External View	Model	Description	Max. Positioning Points	Input Voltage	Power Supply Capacity	Standard Price	See Page
Positioner Mode		SCON-C-20①-NP-2-②	Positioning is possible for up to 512 points	512 points	Single-phase AC100V Single-phase AC200V Three-phase AC200V (XSEL-P/Q only)	360VA max.  * When operating a 150W single-axis model	-	→ P547
Solenoid Valve Mode			Operable with the same controls as the solenoid valve	7 points				
Serial Communication Type			Dedicated to serial communication	64 points				
Pulse Train Input Control Type			Dedicated to pulse train input	(-)				
Program Control 1-2 Axes Type		SSEL-C-1-20①-NP-2-②	Programmed operation is possible Operation is possible on up to 2 axes	20000 points			-	→ P577
Program Control 1-6 Axes Type		XSEL-③-1-20①-N1-EEE-2-④	Programmed operation is possible Operation is possible on up to 6 axes	20000 points			-	→ P587

\* For SSEL and XSEL, only applicable to the single-axis model.  
 \* ① is a placeholder for the encoder type (1: incremental, A: absolute).  
 \* ② is a placeholder for the power supply voltage (1: 100V, 2: single-phase 200V).  
 \* ③ is a placeholder for the XSEL type name ("J", "K", "P", or "Q").  
 \* ④ is a placeholder for the power supply voltage (1: 100V, 2: single-phase 200V, or 3: three-phase 200V).

- Slider Type
- Mini
- Standard
- Controllers Integrated
- Rod Type
- Mini
- Standard
- Controllers Integrated
- Table/Arm /Flat Type
- Mini
- Standard
- Gripper/ Rotary Type
- Linear Servo Type
- Cleanroom Type
- Splash Proof
- Controllers
- PMEC /AMEC
- PSEP /ASEP
- ROBO NET
- ERC2
- PCON
- ACON
- SCON
- PSEL
- ASEL
- SSEL
- XSEL
- Pulse Motor
- Servo Motor (24V)
- Servo Motor (200V)
- Linear Servo Motor

# RCS2-A5R

ROBO Cylinder Arm Type Side-Mounted Motor 52mm Width 200V Servo Motor Ball Screw

■ Configuration: **RCS2** — **A5R** —  — **20** —  —  —  —  —

Series — Type — Encoder — Motor — Lead — Stroke — Compatible Controllers — Cable Length — Option

I : Incremental  
A : Absolute

20 : 20W Servo motor

12 : 12mm  
6 : 6mm

50 : 50mm  
200 : 200mm (50mm pitch increments)

T1 : XSEL-J/K  
T2 : SCON  
SSEL  
XSEL-P/Q

N : None  
P : 1m  
S : 3m  
M : 5m  
X  : Custom  
R  : Robot cable

See Options below  
\* Be sure to specify which side the motor is to be mounted (ML/MR).

\* See page Pre-35 for an explanation of the naming convention.

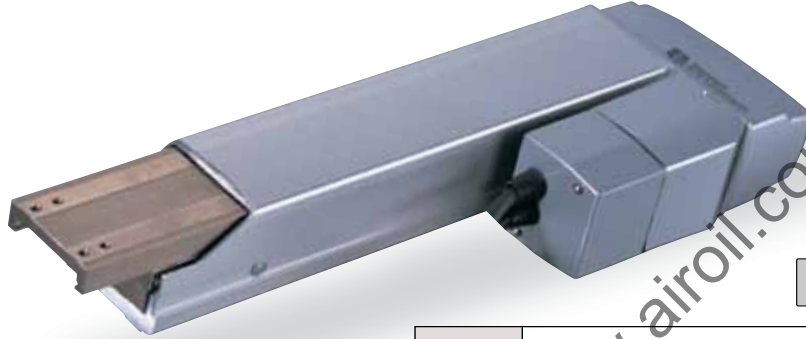

Technical References P. A-5

**POINT**  
Notes on Selection

(1) When the stroke increases, the maximum speed will drop to prevent the ball screw from reaching the critical rotational speed. Use the actuator specification table below to check the maximum speed at the stroke you desire.

(2) The load capacity is based on operation at an acceleration of 0.2G. This is the upper limit of the acceleration.

### Actuator Specifications

#### Lead and Load Capacity

Model	Motor Output (W)	Lead (mm)	Max. Load Capacity		Rated Thrust (N)	Stroke (mm)
			Horizontal (kg)	Vertical (kg)		
RCS2-A5R-①-20-12-②-③-④-B-⑤	20	12	-	2	33.3	50~200 (50mm increments)
RCS2-A5R-①-20-6-②-③-④-B-⑤		6	-	4		

Legend: ① Encoder ② Stroke ③ Compatible controller ④ Cable length ⑤ Options

#### Stroke and Maximum Speed

Stroke Lead	50 ~ 200 (50mm increments)	
	12	400
6	200	

(Unit: mm/s)

### Encoder & Stroke List

② Stroke (mm)	Standard Price	
	① Encoder	
	Incremental	Absolute
50	-	-
100	-	-
150	-	-
200	-	-

### ④ Cable List

Type	Cable Symbol	Standard Price
Standard Type	P (1m)	-
	S (3m)	-
	M (5m)	-
Special Lengths	X06 (6m) ~ X10 (10m)	-
	X11 (11m) ~ X15 (15m)	-
	X16 (16m) ~ X20 (20m)	-
Robot Cable	R01 (1m) ~ R03 (3m)	-
	R04 (4m) ~ R05 (5m)	-
	R06 (6m) ~ R10 (10m)	-
	R11 (11m) ~ R15 (15m)	-
	R16 (16m) ~ R20 (20m)	-

\* See page A-39 for cables for maintenance.

### ⑤ Option List

Name	Option Code	See Page	Standard Price
Brake (standard)	B	→ A-25	-
Bottom-mounted motor	MB	→ A-33	
Right-mounted motor	MR	→ A-33	
Left-mounted motor	ML	→ A-33	
Reversed-home	NM	→ A-33	

### Actuator Specifications

Item	Description
Drive System	Ball screw ø8mm C10 grade (ball screw speed reduced by 1/2 by timing belt)
Positioning Repeatability	±0.02mm
Lost Motion	0.1mm or less
Base	Material: Aluminum (white alumite treated)
Allowable Load Moment	Ma: 4.5 N·m Mb: 5.4 N·m Mc: 4.1 N·m
Ambient Operating Temp./Humidity	0~40°C, 85% RH or less (non-condensing)

#### Directions of Allowable Load Moments

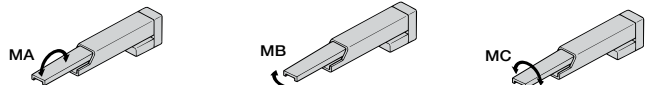

5,000 km service life

Dimensions

CAD drawings can be downloaded from IAI website. [www.intelligentactuator.com](http://www.intelligentactuator.com)

For Special Orders P. A-9



- \*1 The motor-encoder cable is connected here. See page A-39 for details on cables.
  - \*2 When homing, the rod moves to the ME; therefore, please watch for any interference with the surrounding objects.
- ME: Mechanical end SE: Stroke end

Bottom-mounted motor (option code: MB)

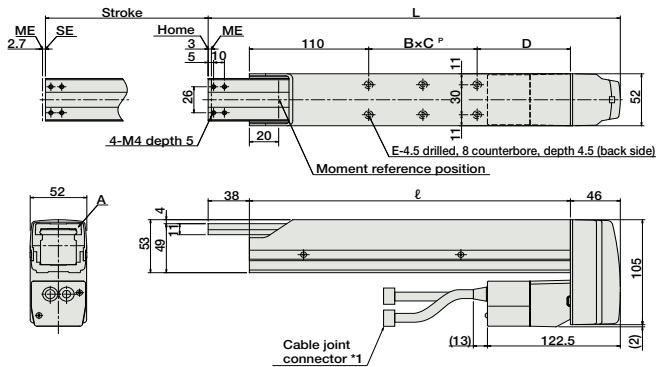

Right-mounted motor (option code: MR)

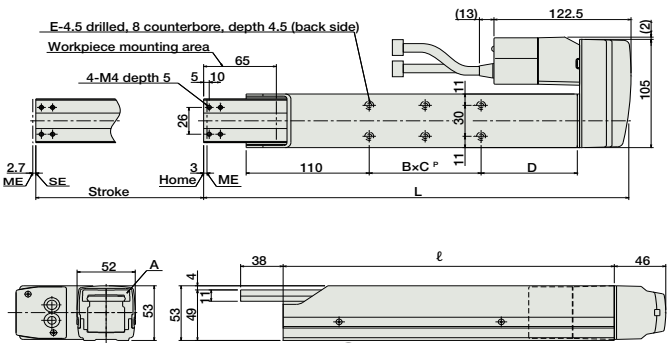

Left-mounted motor (option code: ML)

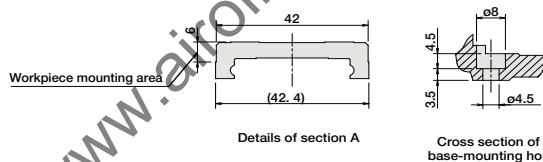
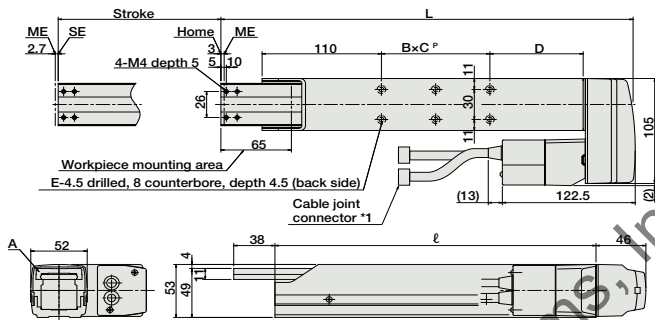

■ Dimensions and Weight by Stroke

Stroke	50	100	150	200
L	280	330	380	430
ℓ	196	246	296	346
BxC*	1×30	1×50	2×50	2×50
D	56	86	86	136
E	4	4	6	6
Weight (kg)	2.2	2.4	2.6	2.8

Note: The 50mm stroke model is only available with a right- or left-mounted motor. Please note that there is no 50mm stroke configuration for the standard model.

③ Compatible Controllers

The RCS2 series actuators can operate with the controllers below. Select the controller according to your usage.

Name	External View	Model	Description	Max. Positioning Points	Input Voltage	Power Supply Capacity	Standard Price	See Page
Positioner Mode		SCON-C-20①-NP-2-②	Positioning is possible for up to 512 points	512 points	Single-phase AC100V Single-phase AC200V Three-phase AC200V (XSEL-P/Q only)	360VA max.  * When operating a 150W single-axis model	-	→ P547
Solenoid Valve Mode			Operable with the same controls as the solenoid valve	7 points				
Serial Communication Type			Dedicated to serial communication	64 points				
Pulse Train Input Control Type			Dedicated to pulse train input	(-)				
Program Control 1-2 Axes Type		SSEL-C-1-20①-NP-2-②	Programmed operation is possible Operation is possible on up to 2 axes	20000 points			-	→ P577
Program Control 1-6 Axes Type		XSEL-③-1-20①-N1-EEE-2-④	Programmed operation is possible Operation is possible on up to 6 axes	20000 points			-	→ P587

- \* For SSEL and XSEL, only applicable to the single-axis model.
- ① is a placeholder for the encoder type (I: incremental, A: absolute).
- ② is a placeholder for the power supply voltage (1: 100V, 2: single-phase 200V).
- ③ is a placeholder for the XSEL type name ("J", "K", "P", or "Q").
- ④ is a placeholder for the power supply voltage (1: 100V, 2: single-phase 200V, or 3: three-phase 200V).

- Slider Type
- Mini
- Standard
- Controllers Integrated
- Rod Type
- Mini
- Standard
- Controllers Integrated
- Table/Arm/Flat Type
- Mini
- Standard
- Gripper/Rotary Type
- Linear Servo Type
- Cleanroom Type
- Splash Proof
- Controllers
- PMEC/AMEC
- PSEP/ASEP
- ROBO NET
- ERC2
- PCON
- ACON
- SCON
- PSEL
- ASEL
- SSEL
- XSEL
- Pulse Motor
- Servo Motor (24V)
- Servo Motor (200V)
- Linear Servo Motor

# RCS2-A6R

ROBO Cylinder Arm Type Side-Mounted Motor 58mm Width 200V Servo Motor Ball Screw

■ Configuration: **RCS2** — **A6R** —  — **30** —  —  —  —  —

Series — Type — Encoder — Motor — Lead — Stroke — Compatible Controllers — Cable Length — Option

I : Incremental  
A : Absolute

30 : 30W Servo motor

12 : 12mm  
6 : 6mm

50 : 50mm  
200 : 200mm (50mm pitch increments)

T1 : XSEL-J/K  
T2 : SCON  
SSEL  
XSEL-P/Q

N : None  
P : 1m  
S : 3m  
M : 5m  
X  : Custom  
R  : Robot cable

See Options below  
\* Be sure to specify which side the motor is to be mounted (ML/MR).

\* See page Pre-35 for an explanation of the naming convention.

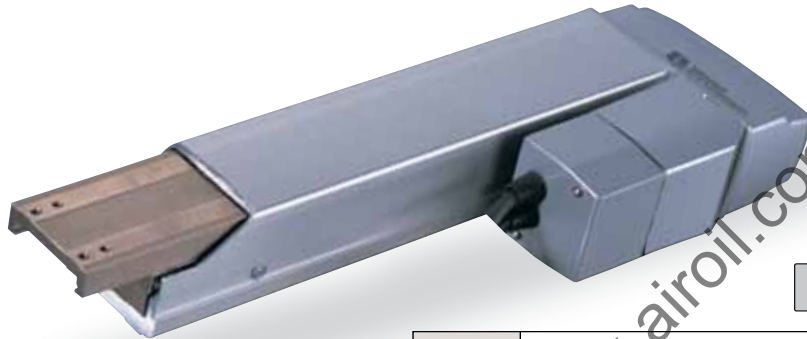

Technical References P. A-5

- POINT**  
Notes on Selection
- When the stroke increases, the maximum speed will drop to prevent the ball screw from reaching the critical rotational speed. Use the actuator specification table below to check the maximum speed at the stroke you desire.
  - The load capacity is based on operation at an acceleration of 0.2G. This is the upper limit of the acceleration.

### Actuator Specifications

#### ■ Lead and Load Capacity

Model	Motor Output (W)	Lead (mm)	Max. Load Capacity		Rated Thrust (N)	Stroke (mm)
			Horizontal (kg)	Vertical (kg)		
RCS2-A6R-①-30-12-②-③-④-B-⑤	30	12	-	3	48.4	50~200 (50mm increments)
RCS2-A6R-①-30-6-②-③-④-B-⑤		6	-	6		

Legend: ① Encoder ② Stroke ③ Compatible controller ④ Cable length ⑤ Options

#### ■ Stroke and Maximum Speed

Stroke Lead	50 ~ 200 (50mm increments)	
	Stroke	Lead
12	12	400
6	6	200

(Unit: mm/s)

### Encoder & Stroke List

② Stroke (mm)	Standard Price	
	① Encoder	
	Incremental	Absolute
50	-	-
100	-	-
150	-	-
200	-	-

### ④ Cable List

Type	Cable Symbol	Standard Price
Standard Type	P (1m)	-
	S (3m)	-
	M (5m)	-
Special Lengths	X06 (6m) ~ X10 (10m)	-
	X11 (11m) ~ X15 (15m)	-
	X16 (16m) ~ X20 (20m)	-
	R01 (1m) ~ R03 (3m)	-
Robot Cable	R04 (4m) ~ R05 (5m)	-
	R06 (6m) ~ R10 (10m)	-
	R11 (11m) ~ R15 (15m)	-
	R16 (16m) ~ R20 (20m)	-

\* See page A-39 for cables for maintenance.

### ⑤ Option List

Name	Option Code	See Page	Standard Price
Brake (standard)	B	→ A-25	-
Bottom-mounted motor	MB	→ A-33	
Right-mounted motor	MR	→ A-33	
Left-mounted motor	ML	→ A-33	
Reversed-home	NM	→ A-33	

### Actuator Specifications

Item	Description
Drive System	Ball screw ø10mm C10 grade (ball screw speed reduced by 1/2 by timing belt)
Positioning Repeatability	±0.02mm
Lost Motion	0.1mm or less
Base	Material: Aluminum (white alumite treated)
Allowable Load Moment	Ma: 8.1 N·m Mb: 10.0 N·m Mc: 6.5 N·m
Ambient Operating Temp./Humidity	0~40°C, 85% RH or less (non-condensing)

#### Directions of Allowable Load Moments

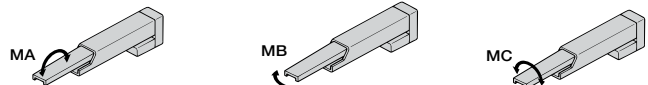

5,000 km service life

Dimensions

CAD drawings can be downloaded from IAI website. [www.intelligentactuator.com](http://www.intelligentactuator.com)

For Special Orders P. A-9



- \*1 The motor-encoder cable is connected here. See page A-39 for details on cables.
  - \*2 When homing, the rod moves to the ME; therefore, please watch for any interference with the surrounding objects.
- ME: Mechanical end SE: Stroke end

Bottom-mounted motor (option code: MB)

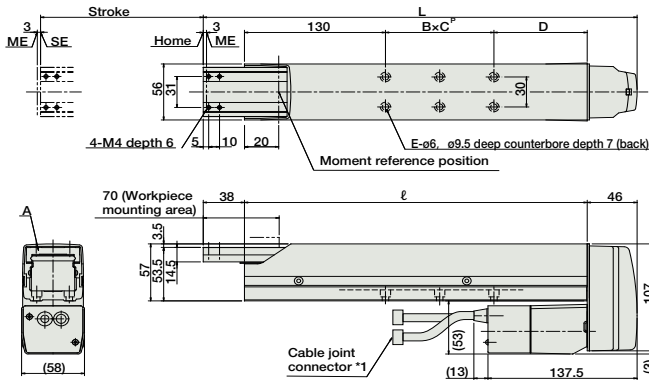

Right-mounted motor (option code: MR)

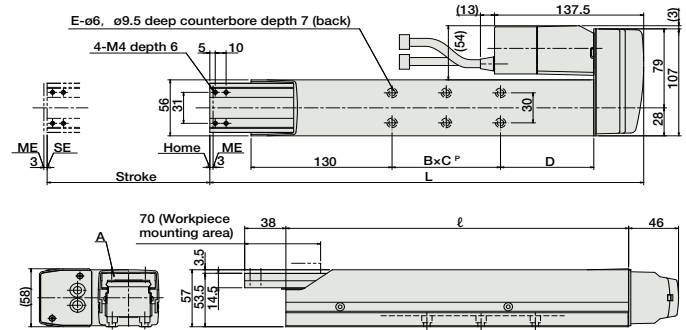

Left-mounted motor (option code: ML)

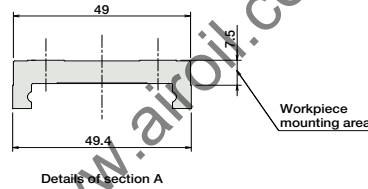
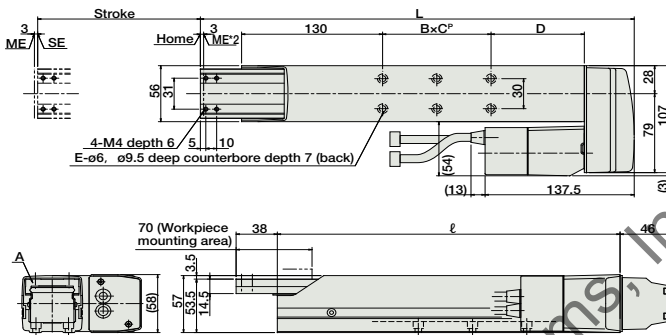

Dimensions and Weight by Stroke

Stroke	50	100	150	200
L	300	350	400	450
ℓ	216	266	316	366
BxC*	1x30	1x50	2x50	2x50
D	56	86	86	136
E	4	4	6	6
Weight (kg)	3.0	3.3	3.6	3.9

Note: The 50mm stroke model is only available with a right- or left-mounted motor. Please note that there is no 50mm stroke configuration for the standard model.

3 Compatible Controllers

The RCS2 series actuators can operate with the controllers below. Select the controller according to your usage.

Name	External View	Model	Description	Max. Positioning Points	Input Voltage	Power Supply Capacity	Standard Price	See Page
Positioner Mode		SCON-C-30D①-NP-2-②	Positioning is possible for up to 512 points	512 points	Single-phase AC100V Single-phase AC200V Three-phase AC200V (XSEL-P/Q only)	360VA max.  * When operating a 150W single-axis model	-	→ P547
Solenoid Valve Mode			Operable with the same controls as the solenoid valve	7 points				
Serial Communication Type			Dedicated to serial communication	64 points				
Pulse Train Input Control Type			Dedicated to pulse train input	(-)				
Program Control 1-2 Axes Type		SSEL-C-1-30D①-NP-2-②	Programmed operation is possible Operation is possible on up to 2 axes	20000 points			-	→ P577
Program Control 1-6 Axes Type		XSEL-③-1-30D①-N1-EEE-2-④	Programmed operation is possible Operation is possible on up to 6 axes	20000 points			-	→ P587

- \* For SSEL and XSEL, only applicable to the single-axis model.
- ① is a placeholder for the encoder type (I: incremental, A: absolute).
- ② is a placeholder for the power supply voltage (1: 100V, 2: single-phase 200V).
- ③ is a placeholder for the XSEL type name ("J", "K", "P", or "Q").
- ④ is a placeholder for the power supply voltage (1: 100V, 2: single-phase 200V, or 3: three-phase 200V).

- Slider Type
- Mini
- Standard
- Controllers Integrated
- Rod Type
- Mini
- Standard
- Controllers Integrated
- Table/Arm/Flat Type
- Mini
- Standard
- Gripper/Rotary Type
- Linear Servo Type
- Cleanroom Type
- Splash Proof
- Controllers
- PMEC/AMEC
- PSEP/ASEP
- ROBO NET
- ERC2
- PCON
- ACON
- SCON
- PSEL
- ASEL
- SSEL
- XSEL
- Pulse Motor
- Servo Motor (24V)
- Servo Motor (200V)
- Linear Servo Motor

# RCS2-F5D

ROBO Cylinder Flat Type Built-In (Direct-Coupled) Motor 55mm Width 200V Servo Motor Ball Screw

■ Configuration: **RCS2** — **F5D** — [ ] — [ ] — [ ] — [ ] — [ ] — [ ] — [ ]

Series — Type — Encoder — Motor — Lead — Stroke — Compatible Controllers — Cable Length — Option

I : Incremental  
A : Absolute

60 : 60W servo motor  
100 : 100W servo motor

16 : 16mm  
8 : 8mm  
4 : 4mm

50 : 50mm  
300 : 300mm (50mm pitch increments)

T1 : XSEL-J/K  
T2 : SCON  
SSEL  
XSEL-P/Q

N : None  
P : 1m  
S : 3m  
M : 5m  
X [ ] : Custom  
R [ ] : Robot cable

B : Brake  
NM : Reversed-home

\* See page Pre-35 for an explanation of the naming convention.

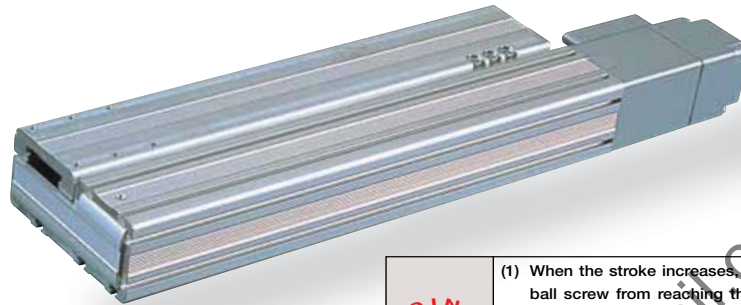

Technical References P. A-5

- POINT**  
Notes on Selection
- (1) When the stroke increases, the maximum speed will drop to prevent the ball screw from reaching the critical rotational speed. Use the actuator specification table below to check the maximum speed at the stroke you desire.
  - (2) The load capacity is based on operation at an acceleration of 0.3G (0.2G for the 4mm lead model). This is the upper limit of the acceleration.

■ Actuator Specifications

■ Lead and Load Capacity

Model	Motor Output (W)	Lead (mm)	Max. Load Capacity Horizontal (kg) / Vertical (kg)	Rated Thrust (N)	Stroke (mm)
RCS2-F5D-①-60-16-②-③-④-⑤	60	16	2.0 / 63.8	127.5	50 ~ 300 (50mm increments)
RCS2-F5D-①-60-8-②-③-④-⑤		8	5.0 / 127.5		
RCS2-F5D-①-60-4-②-③-④-⑤		4	11.5 / 255.1		
RCS2-F5D-①-100-16-②-③-④-⑤	100	16	3.5 / 105.8	212.7	
RCS2-F5D-①-100-8-②-③-④-⑤		8	9.0 / 212.7		
RCS2-F5D-①-100-4-②-③-④-⑤		4	18.0 / 424.3		

Legend: ① Encoder ② Stroke ③ Compatible controller ④ Cable length ⑤ Options

■ Stroke and Maximum Speed

Stroke Lead	50 ~ 300 (50mm increments)
16	800
8	400
4	200

(Unit: mm/s)

■ Encoder & Stroke List

② Stroke (mm)	Standard Price			
	① Encoder			
	Incremental		Absolute	
	Motor Output (W)		Motor Output (W)	
	60W	100W	60W	100W
50	-	-	-	-
100	-	-	-	-
150	-	-	-	-
200	-	-	-	-
250	-	-	-	-
300	-	-	-	-

④ Cable List

Type	Cable Symbol	Standard Price
Standard Type	P (1m)	-
	S (3m)	-
	M (5m)	-
Special Lengths	X06 (6m) ~ X10 (10m)	-
	X11 (11m) ~ X15 (15m)	-
	X16 (16m) ~ X20 (20m)	-
Robot Cable	R01 (1m) ~ R03 (3m)	-
	R04 (4m) ~ R05 (5m)	-
	R06 (6m) ~ R10 (10m)	-
	R11 (11m) ~ R15 (15m)	-
	R16 (16m) ~ R20 (20m)	-

\* See page A-39 for cables for maintenance.

⑤ Option List

Name	Option Code	See Page	Standard Price
Brake	B	→ A-25	-
Reversed-home	NM	→ A-33	-

■ Actuator Specifications

Item	Description
Drive System	Ball screw ø12mm C10 grade
Positioning Repeatability	±0.02mm
Lost Motion	0.05mm or less
Base	Material: Aluminum (white alumite treated)
Allowable Dynamic Moment (*)	Ma: 4.5 N·m Mb: 5.4 N·m Mc: 4.1 N·m
Ambient Operating Temp./Humidity	0 ~ 40°C, 85% RH or less (non-condensing)

(\*) Based on a 5,000km service life.  
Directions of Allowable Load Moments MB



Dimensions

CAD drawings can be downloaded from IAI website. [www.intelligentactuator.com](http://www.intelligentactuator.com)

For Special Order P. A-9



\* To change the direction of the home position, arrangements must be made to send in the product. Please make a note of it.

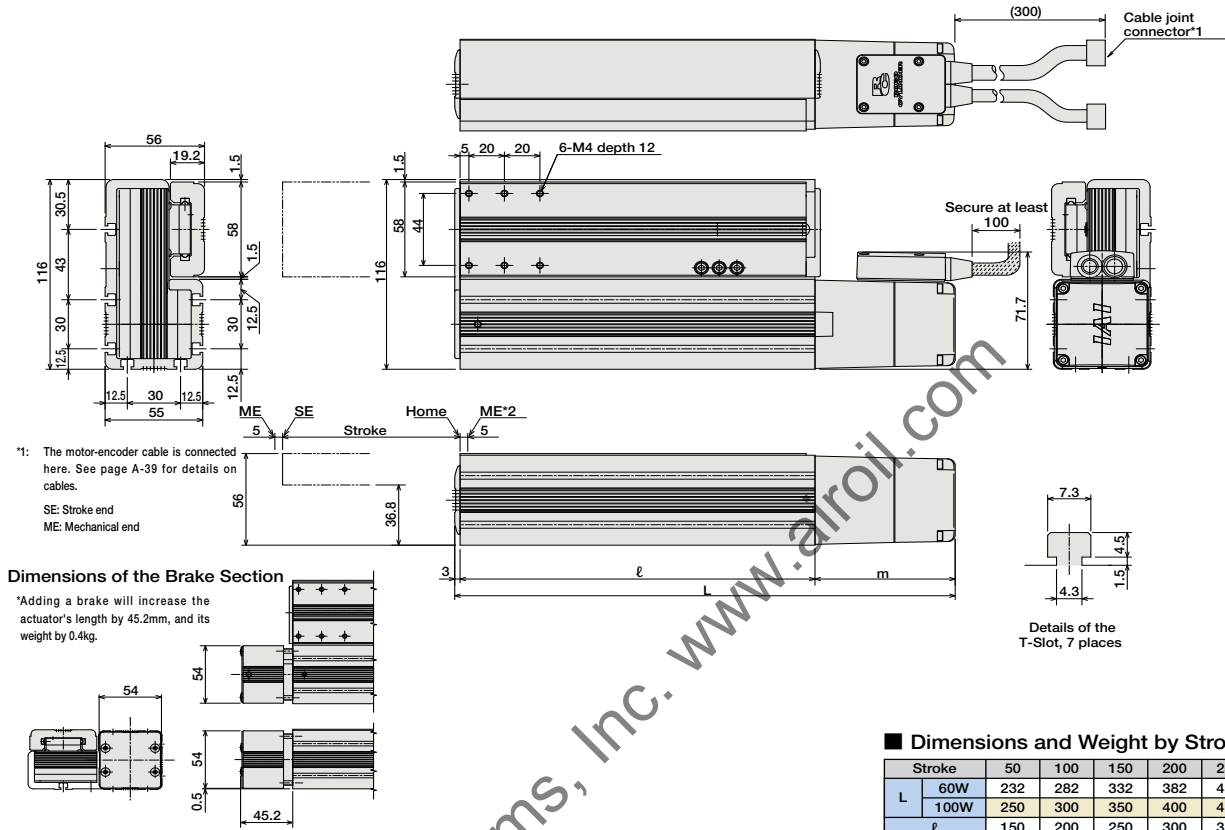

\*1: The motor-encoder cable is connected here. See page A-39 for details on cables.  
SE: Stroke end  
ME: Mechanical end

Dimensions of the Brake Section

\*Adding a brake will increase the actuator's length by 45.2mm, and its weight by 0.4kg.

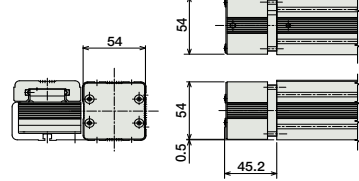

■ Dimensions and Weight by Stroke

Stroke	Stroke						
	50	100	150	200	250	300	
L	60W	232	282	332	382	432	482
	100W	250	300	350	400	450	500
l	60W	150	200	250	300	350	400
	100W	79					
m	60W	97					
	100W	97					
Weight (kg)	60W	2.1	2.5	3	3.4	3.9	4.3
	100W	2.3	2.7	3.2	3.6	4.1	4.5

③ Compatible Controllers

The RCS2 series actuators can operate with the controllers below. Select the controller according to your usage.

Name	External View	Model	Description	Max. Positioning Points	Input Voltage	Power Supply Capacity	Standard Price	See Page
Positioner Mode		SCON-C-60 ①-NP-2-② SCON-C-100 ①-NP-2-②	Positioning is possible for up to 512 points	512 points	Single-phase AC100V Single-phase AC200V Three-phase AC200V (XSEL-P/Q only)	360VA max. * Single-axis model operated at 150W	-	→ P547
Solenoid Valve Mode			Operable with the same controls as the solenoid valve	7 points				
Serial Communication Type			Dedicated to serial communication	64 points				
Pulse Train Input Control Type			Dedicated to pulse train input	(-)				
Program Control 1-2 Axes Type		SSEL-C-1-60 ①-NP-2-② SSEL-C-1-100 ①-NP-2-②	Programmed operation is possible Operation is possible on up to 2 axes	20000 points			-	→ P577
Program Control 1-6 Axes Type		XSEL-③-1-60 ①-N1-EEE-2-④ XSEL-③-1-100 ①-N1-EEE-2-④	Programmed operation is possible Operation is possible on up to 6 axes	20000 points			-	→ P587

\* For SSEL and XSEL, only applicable to the single-axis model.  
 \* ① is a placeholder for the encoder type (I: incremental, A: absolute).  
 \* ② is a placeholder for the power supply voltage (1: 100V, 2: single-phase 200V).  
 \* ③ is a placeholder for the XSEL type name ("J", "K", "P", or "Q").  
 \* ④ is a placeholder for the power supply voltage (1: 100V, 2: single-phase 200V, or 3: three-phase 200V).

- Slider Type
- Mini
- Standard
- Controllers Integrated
- Rod Type
- Mini
- Standard
- Controllers Integrated
- Table/Arm /Flat Type
- Mini
- Standard
- Gripper/ Rotary Type
- Linear Servo Type
- Cleanroom Type
- Splash Proof
- Controllers
- PMEC /AMEC
- PSEP /ASEP
- ROBO NET
- ERC2
- PCON
- ACON
- SCON
- PSEL
- ASEL
- SSEL
- XSEL
- Pulse Motor
- Servo Motor (24V)
- Servo Motor (200V)
- Linear Servo Motor