

PZN-plus

Pneumatic • 3-Finger Centric Gripper • Universal Gripper



Sizes
40 ... 300



Weight
0.13 kg ... 46 kg

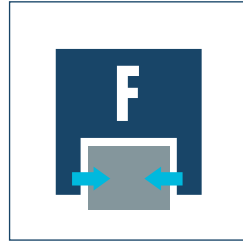

Gripping force
255 N ... 35500 N

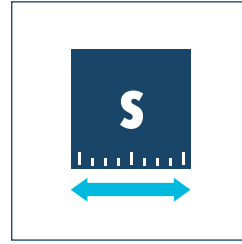

Stroke per finger
2 mm ... 35 mm



Workpiece weight
1.3 kg ... 127.5 kg

Application example



Insertion tool for assembling small to medium-sized axles. Thanks to the rotary feed-through, the axles can be turned several times to an unlimited extent ($> 360^\circ$). Slip ring contacts integrated in the rotary feed-through reliably supply the gripper with power.

- 1 3-Finger Centric Gripper PZN-plus
- 2 Rotary feed-through DDF

Universal Gripper

universal Concentric Gripper with high gripping force and maximum moments thanks to multi-tooth guidance

Field of application

Multi-purpose thanks to the diverse range of accessories. Can also be used in fields of application with special requirements to the gripper (temperature, chemical resistance, dirt, and many more).

Your advantages and benefits

Robust multi-tooth guidance

for precise handling

High maximum moments possible

suitable for using long gripper fingers

Wedge-hook design

for high power transmission and synchronized gripping

Air supply via hose-free direct connection or screw connections

for the flexible supply of compressed air in all automation systems

Comprehensive sensor accessory program

for versatile interrogation possibilities and control of stroke position

Manifold options

for perfect adaption to your case of application (dust protection, high temperature, anti-corrosion and many more)



General note to the series

Principle of function

Wedge-hook kinematics

Housing material

Aluminum alloy, hard-anodized

Base jaw material

Steel

Actuation

pneumatic, with filtered compressed air (10 microns): dry, lubricated or non-lubricated

Pressure medium: Required quality class of compressed air according to

DIN ISO 8573-1: 6 4 4

Warranty

36 months (details, general terms and conditions and operation manuals can be downloaded under www.schunk.com)

Scope of delivery

Brackets for proximity switches, centering sleeves, O-rings for direct connection, assembly and operating manual with manufacturer's declaration

Sectional diagram

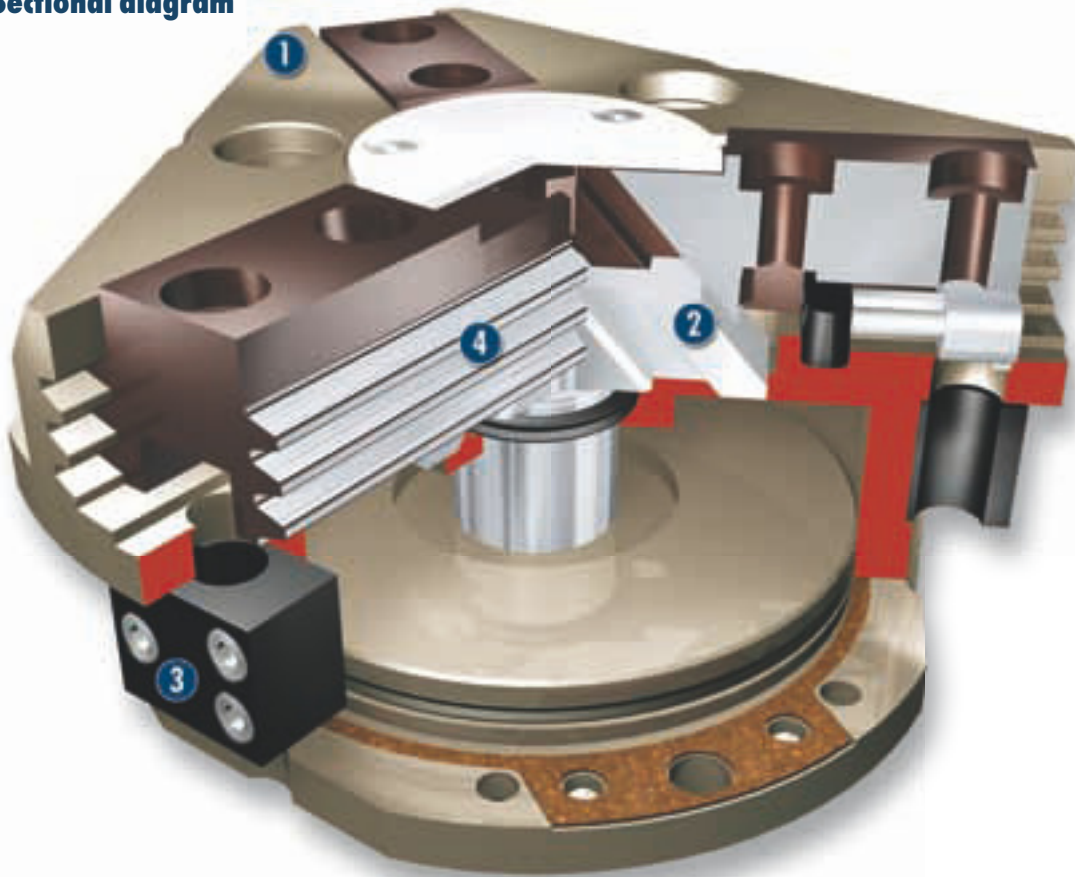

- 1 Housing**
weight-optimized through application of hard-anodized, high-strength aluminum alloy
- 2 Wedge-hook design**
for high power transmission and centric gripping
- 3 Sensor system**
Brackets for proximity switches and adjustable control cams in the housing
- 4 Multiple-tooth guidance**
precise gripping through base jaw guidance with a high load capacity and a minimum play

Functional description

The piston is moved up and down by compressed air. Through its angled active surfaces, the wedge hook transforms this movement into the lateral, synchronous gripping movement of both base jaws.

Options and special information

Dust-protection version

Absolutely sealed, increased degree of protection against the ingress of materials, for use in dusty environments

Anti-corrosion version

for use in corrosion-inducing atmospheres

High-temperature version

for use in hot environments

Force intensified version

if higher gripping forces are required

Accessories

Accessories from SCHUNK – the suitable supplement for maximum functionality, reliability and performance of all automation modules.

Sensor system



Fittings



Universal intermediate jaw



Compensation unit



Protection cover



Quick-change Jaw System



Pressure maintenance valve



Finger blanks



Force measuring jaws



Analog position sensor



Flexible Position Sensor



Sensor cables



Sensor Distributor



① For the exact size of the required accessories, availability of this size and the designation and ID, please refer to the additional views at the end of the size in question. You will find more detailed information on our accessory range in the "Accessories" catalog section.

General note to the series

Gripping force

is the arithmetic total of the gripping force applied to each finger at distance P (see illustration) measured from the upper edge of the gripper.

Finger length

The finger length is measured from the upper edge of the gripper housing in the direction of the main axis.

Repeat accuracy

is defined as the spread of the limit position after 100 consecutive strokes.

Workpiece weight

The recommended workpiece weight is calculated for a force-type connection with a coefficient of friction of 0.1 and a safety factor of 2 against slippage of the workpiece on acceleration due to gravity g. Considerably heavier workpiece weights are permitted with form-fit gripping.

Closing and opening times

Closing and opening times are purely the times that the base jaws or fingers are in motion. Valve switching times, hose filling times or PLC reaction times are not included in the above times and must be taken into consideration when determining cycle times.

PZN-plus 200

Pneumatic • 3-Finger Centric Gripper • Universal Gripper



Gripping force, I.D. gripping

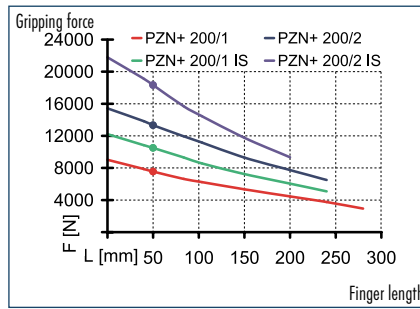

Gripping force, O.D. gripping

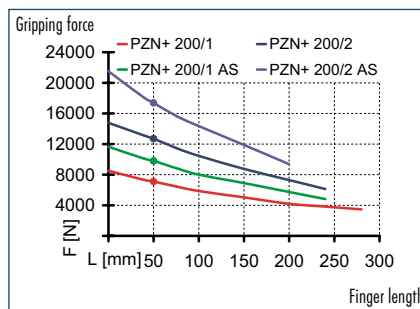

Finger load

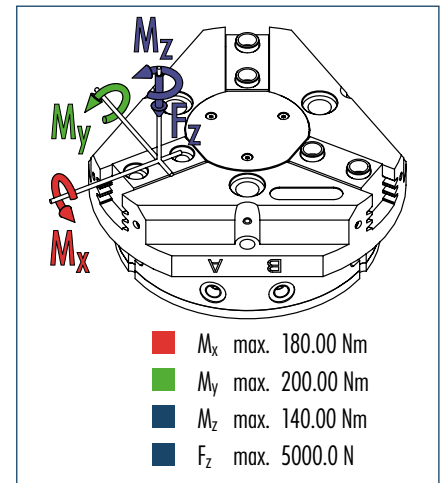

① The indicated moments and forces are static values, apply per base jaw and may occur simultaneously. M_y may arise in addition to the moment generated by the gripping force itself. If the max. permitted finger weight is exceeded, it is imperative to throttle the air pressure so that the jaw movement occurs without any hitting or bouncing. Service life may be reduced.

Technical data

Description	PZN-plus 200-1	PZN-plus 200-2	PZN-plus 200-1-AS	PZN-plus 200-2-AS	PZN-plus 200-1-IS	PZN-plus 200-2-IS
ID	0303315	0303415	0303515	0303615	0303545	0303645
Stroke per finger [mm]	25	14	25	14	25	14
Closing force [N]	7100	12700	9800	17380		
Opening force [N]	7540	13330			10500	18330
Min. spring force [N]			2700	4680	2960	5000
Weight [kg]	11	11	15.7	15.7	15.7	15.7
Recommended workpiece weight [kg]	35.5	63.5	35.5	63.5	35.5	63.5
Air consumption per double stroke [cm ³]	1040	1040	1725	1725	1725	1725
Min./max. operating pressure [bar]	2/8	2/8	4/6.5	4/6.5	4/6.5	4/6.5
Nominal operating pressure [bar]	6	6	6	6	6	6
Closing/opening time [s]	1.2/1.2	1.2/1.2	1/1.5	1/1.5	1.5/1	1.5/1
Max. permitted finger length [mm]	280	240	240	200	240	200
Max. permitted weight per finger [kg]	6.5	6.5	6.5	6.5	6.5	6.5
IP class	40	40	40	40	40	40
Min./max. ambient temperature [°C]	-10/90	-10/90	-10/90	-10/90	-10/90	-10/90
Repeat accuracy [mm]	0.05	0.05	0.05	0.05	0.05	0.05
Cleanroom class						
ISO-classification 14644-1	5	5	5	5	5	5

OPTIONS and their characteristics

Description	37303315	37303415	37303515	37303615	37303545	37303645
Dust-protection version	37303315	37303415	37303515	37303615	37303545	37303645
IP class	64	64	64	64	64	64
Weight [kg]	12	12	16.7	16.7	16.7	16.7
Anti-corrosion version	38303315	38303415	38303515	38303615	38303545	38303645
High-temperature version	39303315	39303415	39303515	39303615	39303545	39303645
Min./max. ambient temperature [°C]	-10/130	-10/130	-10/130	-10/130	-10/130	-10/130
Precision version	0303345	0303445	0303495	0303595		

Main view

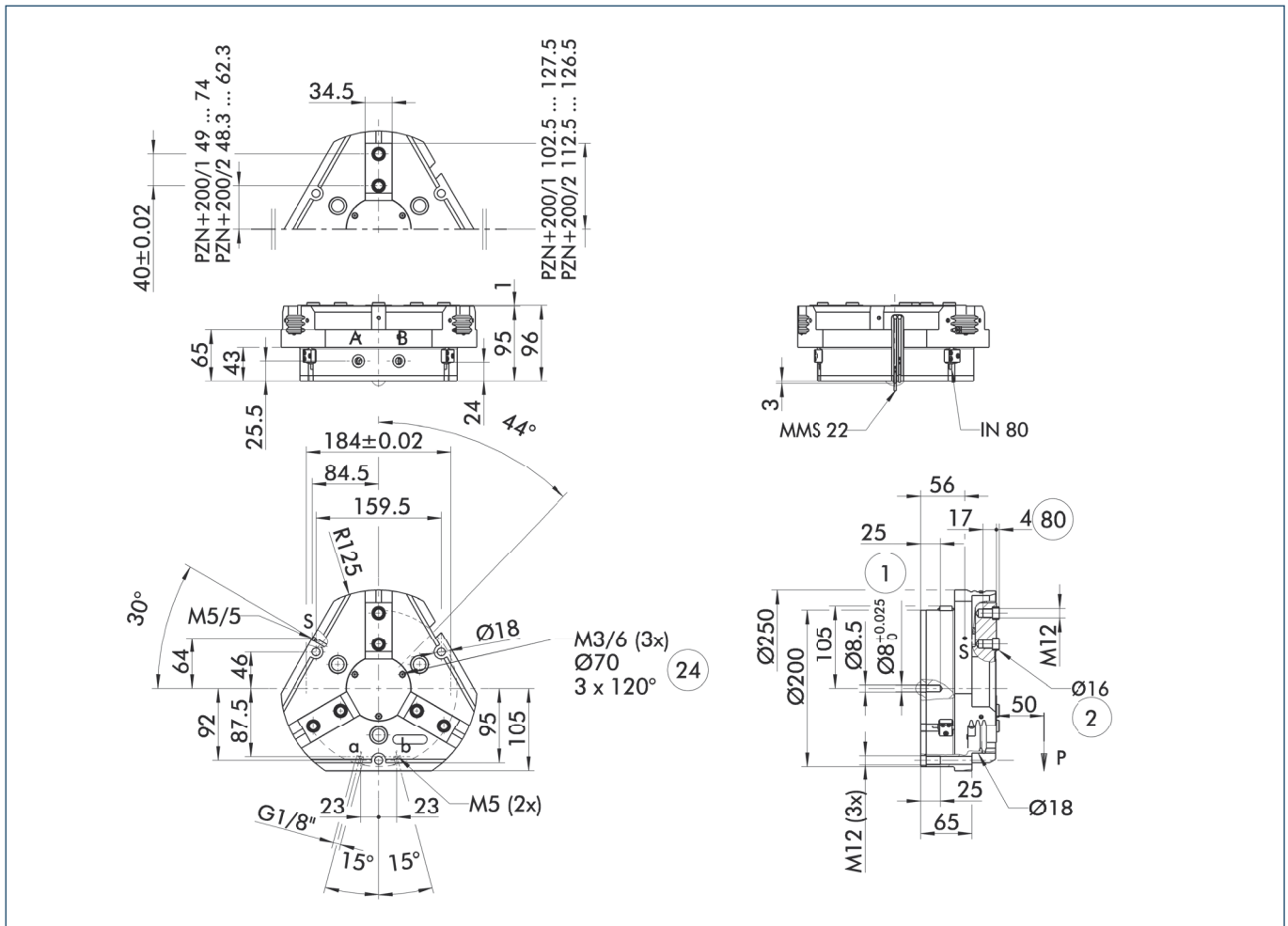

The drawing shows the gripper in the basic version with closed jaws, the dimensions do not include the options described below.

① The SDV-P pressure maintenance valve can also be used for I.D. or O.D. gripping alternatively or in addition to the spring-loaded, mechanical gripping force maintenance device (see "Accessories" catalog section).

- A, a Main/direct connection, gripper opening
- B, b Main/direct connection, gripper closing
- S Air purge connection
- ① Gripper connection
- ② Finger connection
- ②④ Bolt circle
- ⑧⑩ Depth of the centering sleeve hole in the matching part

Hose-free direct connection

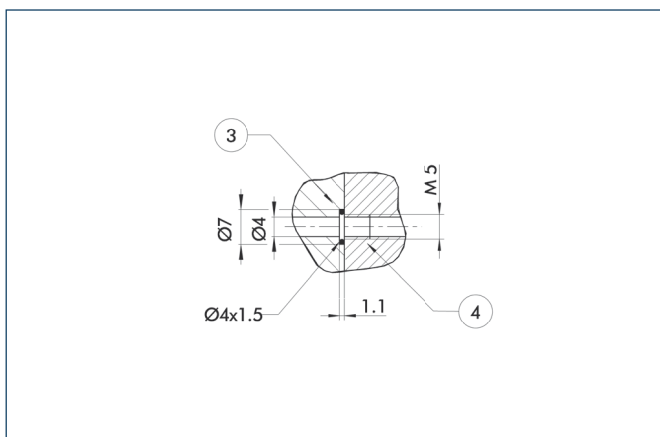

- ③ Adapter
- ④ Gripper

The direct connection is used for supplying compressed air without hoses. Instead, the pressure medium is fed through bore-holes in the mounting plate.

AS/IS gripping force maintenance device

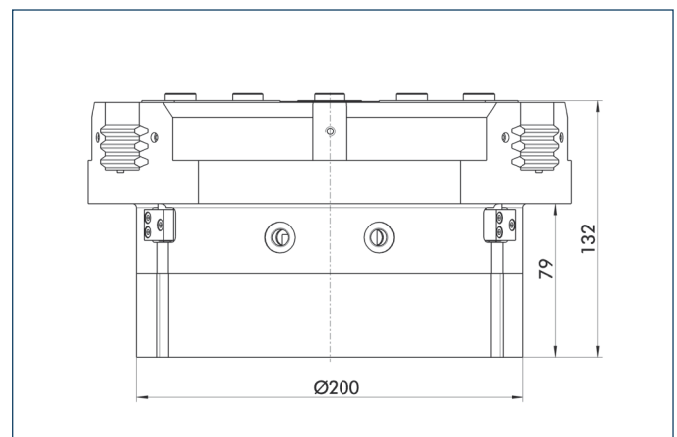

The mechanical gripping force maintenance device ensures a minimum gripping force even in case of pressure drop. This acts as closing force in the AS version, and as opening force in the IS version. In addition, the gripping force maintenance device can also be used for increasing the gripping force or for single-acting gripping.

PZN-plus 200

Pneumatic • 3-Finger Centric Gripper • Universal Gripper

Dust-protection version

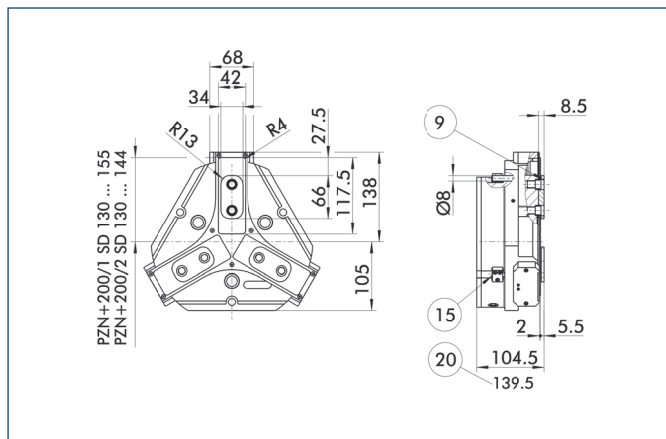

- ⑨ For mounting screw connection diagram, see basic version ⑮ Sealing bolt
 ⑳ For AS / IS version

The "dust-protection" option increases the degree of protection against penetrating substances. The screw connection diagram shifts by the height of the intermediate jaw. The finger length is still measured from the upper edge of the gripper housing.

Spring-loaded pressure piece

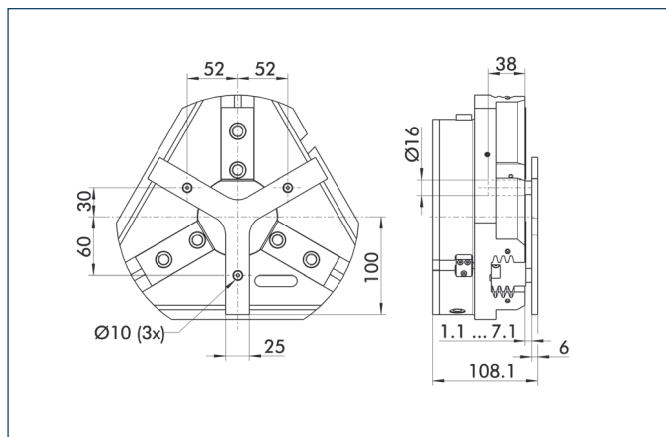

For spring-supported positioning of the workpiece against a stop after the gripper has opened. Especially developed for loading machines.

Description	ID	Stroke	Min. force
Spring-loaded pressure piece			
A-PZN-plus/DPZ-plus 200	0303725	6 mm	247 N

- ① The pressure piece cannot be combined with the dust-protection version. Please contact us if you require a special pressure piece.

Precision version

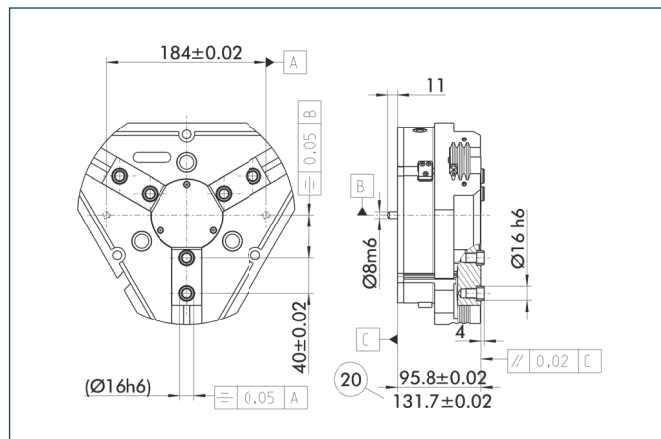

- ⑳ For AS / IS version

The indicated tolerances just refer to the types of precision versions shown in the chart of technical specifications. All other types of precision versions are available on request.

Universal intermediate jaw

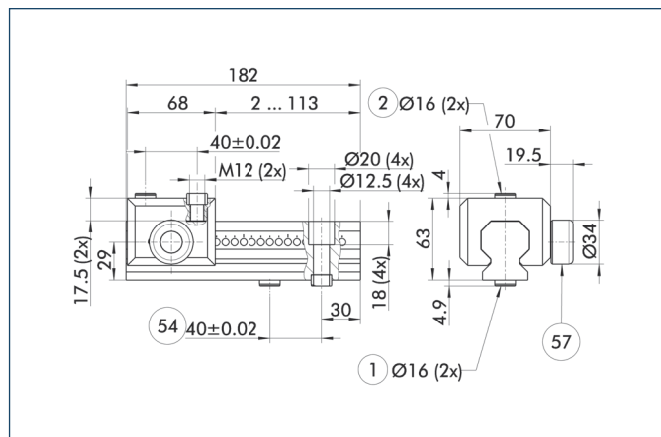

- ① Gripper connection ⑤④ Optional right or left connection
 ② Finger connection ⑤⑦ Locking

The universal intermediate jaw allows fast tool-free and reliable plugging and shifting of top jaws at the gripper.

Description	ID	Grid dimension
Universal intermediate jaw		
UZB 200	0300047	7 mm
UZB-S 200	5518275	7 mm

- ① The slide UZB-S can be removed completely and has to be ordered separately. Moreover, it allows a fast jaw change.

Force measuring jaws

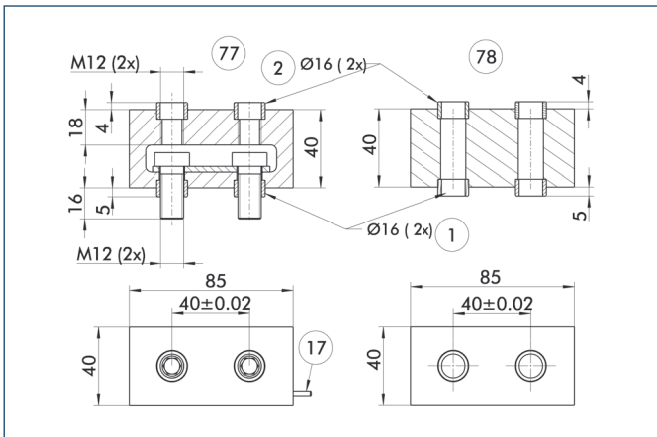

- ① Gripper connection
- ② Finger connection
- ⑦ Active intermediate jaws
- ⑧ Passive intermediate jaws
- ⑰ Cable outlet

Force measuring jaws measure gripping forces, but can also determine workpiece weights or dimensional deviations. There are active and passive intermediate jaws (FMS-ZBA or FMS-ZBP). At least one active force measuring jaw is required per gripper, the rest can be passive. For each active jaw, a FMS-A1 control unit and a FMS-A connection cable are required.

Description	ID
Active intermediate jaws	
FMS-ZBA 200	0301842
Passive intermediate jaws	
FMS-ZBP 200	0301843
Electronic Processor	
FMS-A2	0301811
Connection cables	
FMS-AK0200	0301820
FMS-AK0500	0301821
FMS-AK1000	0301822
FMS-AK2000	0301823

Finger blanks

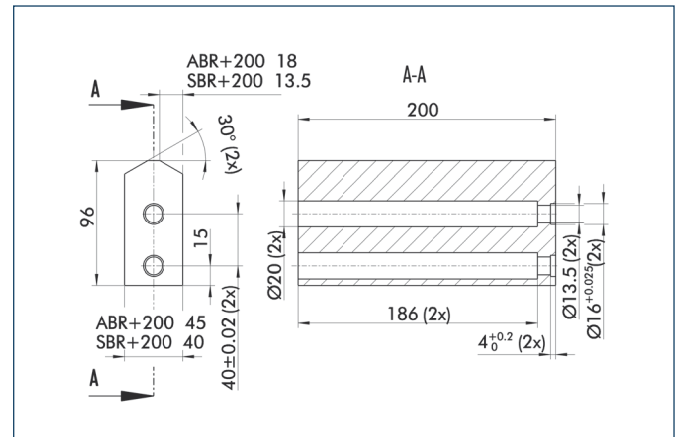

Finger blanks for customized subsequent machining

Description	ID	Material	Scope of delivery
Finger blanks			
ABR-plus 200	0300015	Aluminum	1
SBR-plus 200	0300025	16 MnCr 5	1

Tolerance compensation unit

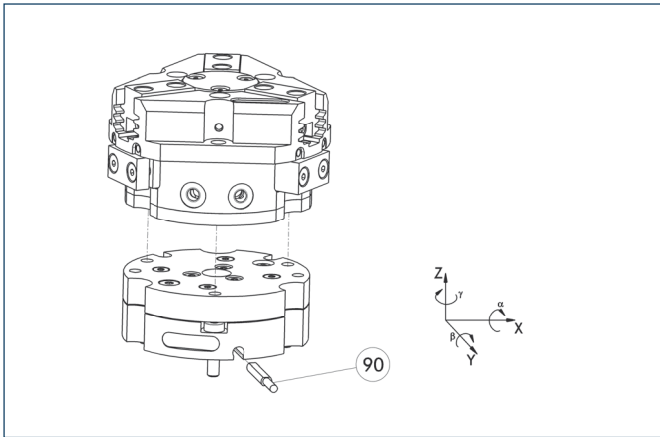

90 Monitoring of locking

Grippers can be directly mounted without an adapter plate. Tolerance compensation unit and gripper have an identical screw connection diagram. Therefore the tolerance compensation units can be assembled later. Please consider the additional assembly height of the tolerance compensation unit. For details see catalog "Robot Accessories".

Description	ID	Locking	Deflection
Compensation unit			
TCU-200-3-MV-Z	0324856	Yes	
TCU-200-3-OV-Z	0324857	No	

Programmable magnetic switch

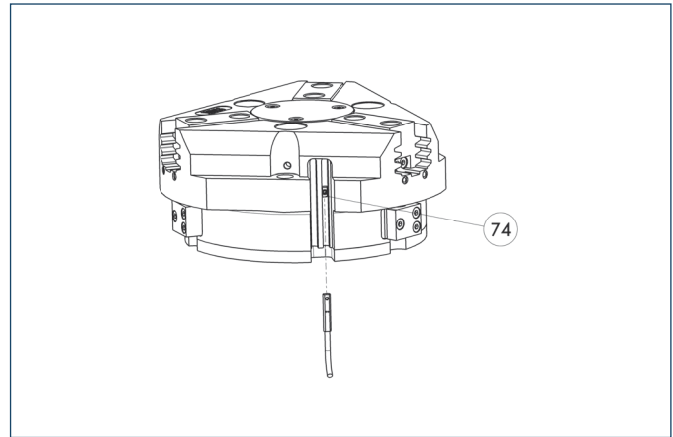

74 Stop for MMS-P

Position monitoring with two programmable positions per sensor. The end position monitoring is mounted in the C-slot.

Description	ID	Recommended product
Programmable magnetic switch		
MMS-P 22-S-M8-PNP	0301370	•
MMSK-P 22-S-PNP	0301371	
Connection cables		
KA BG08-L 4P-0500	0307767	
KA BG08-L 4P-1000	0307768	
KA BW08-L 4P-0500	0307765	
KA BW08-L 4P-1000	0307766	
Sensor Distributor		
V2-M8-4P-2XM8-3P	0301380	

- ① Please note the minimum permitted bending radii for the sensor cables, which are generally 35 mm.
- ① Per gripper one sensor (closer/NO) is required, optionally a cable extension.

Electronic magnetic switches

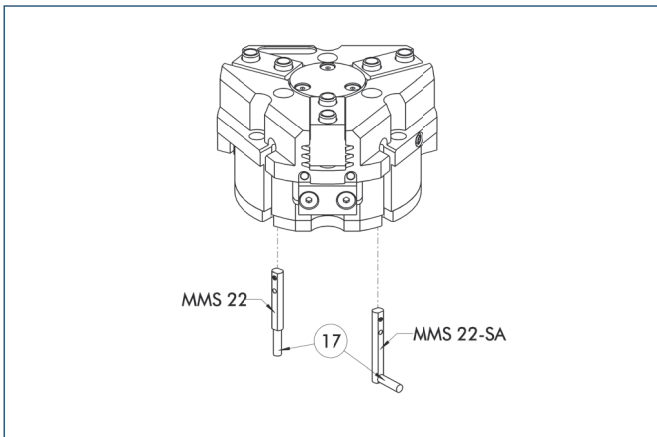

⑰ Cable outlet

End position monitoring for mounting in the C-slot

Description	ID	Recommended product
Electronic magnetic switches		
MMS 22-S-M5-PNP	0301438	
MMS 22-S-M5-NPN	0301439	
MMS 22-S-M8-PNP	0301432	•
MMS 22-S-M8-NPN	0301433	
MMSK 22-S-PNP	0301434	
MMSK 22-S-NPN	0301435	
Electronic magnetic switches with lateral cable outlet		
MMS 22-S-M5-PNP-SA	0301448	
MMS 22-S-M5-NPN-SA	0301449	
MMS 22-S-M8-PNP-SA	0301442	•
MMS 22-S-M8-NPN-SA	0301443	
MMSK 22-S-PNP-SA	0301444	
MMSK 22-S-NPN-SA	0301445	
Reed Switches		
RMS 22-S-M8	0377720	•
Connection cables		
KA BG05-L 3P-0300	0301652	
KA BG08-L 3P-0300-PNP	0301622	
KA BG08-L 3P-0500-PNP	0301623	
KA BW05-L 3P-0300	0301650	
KA BW08-L 3P-0300-NPN	0301602	
KA BW08-L 3P-0300-PNP	0301594	
KA BW08-L 3P-0500-NPN	9641116	
KA BW08-L 3P-0500-PNP	0301502	
Cable extensions		
KV BW08-SG08 3P-0030-PNP	0301495	
KV BW08-SG08 3P-0100-PNP	0301496	
KV BW08-SG08 3P-0200-PNP	0301497	

① Two sensors (closer/NO) are required for each gripper, plus extension cables as an option.

① Please note the minimum permitted bending radii for the sensor cables, which are generally 35 mm.

Inductive proximity switches

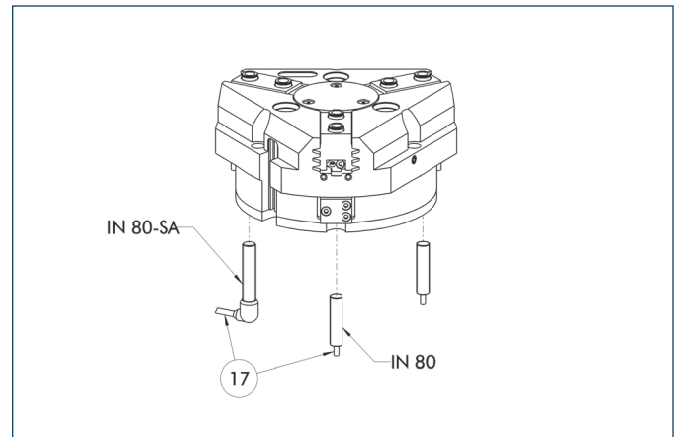

⑰ Cable outlet

End position monitoring for direct mounting

Description	ID	Recommended product
Inductive proximity switches		
IN 80-S-M8	0301478	•
IN 80-S-M12	0301578	
INK 80-S	0301550	
Inductive proximity switch with lateral outlet		
IN 80-S-M12-SA	0301587	
IN 80-S-M8-SA	0301483	•
INK 80-S-SA	0301566	
Connection cables		
KA BG08-L 3P-0300-PNP	0301622	
KA BG08-L 3P-0500-PNP	0301623	
KA BG12-L 3P-0500-PNP	30016369	
KA BW08-L 3P-0300-PNP	0301594	
KA BW08-L 3P-0500-PNP	0301502	
KA BW12-L 3P-0300-PNP	0301503	
KA BW12-L 3P-0500-PNP	0301507	
Cable extensions		
KV BG12-SG12 3P-0030-PNP	0301999	
KV BG12-SG12 3P-0060-PNP	0301998	
KV BW08-SG08 3P-0030-PNP	0301495	
KV BW08-SG08 3P-0100-PNP	0301496	
KV BW08-SG08 3P-0200-PNP	0301497	
KV BW12-SG12 3P-0030-PNP	0301595	
KV BW12-SG12 3P-0100-PNP	0301596	
KV BW12-SG12 3P-0200-PNP	0301597	

① Two sensors (closer/NO) are required for each gripper, plus extension cables as an option.

① Please note the minimum permitted bending radii for the sensor cables, which are generally 35 mm.



You can find more detailed information and individual parts of the above-mentioned accessories in the "Accessories" catalog section.

Cylindrical Reed Switches

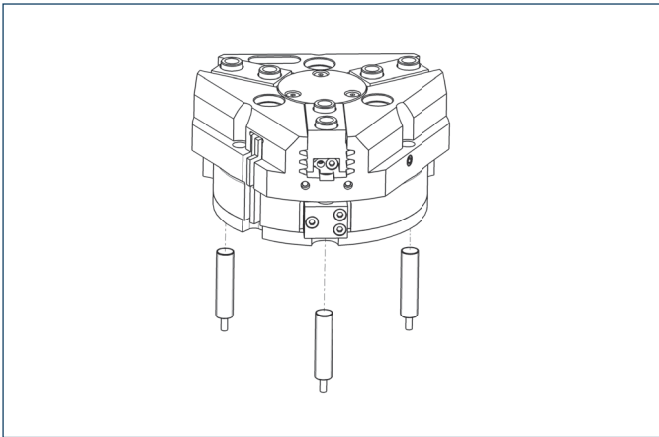

End position monitoring mounted with mounting kit

Description	ID
Mounting kit for proximity switch	
AS-RMS 80 PGN/PZN-plus 160-380	0377727
Reed Switches	
RMS 80-S-M8	0377721

- ① Two sensors (closer/NO) are required for each gripper, plus extension cables as an option.
- ① This mounting kit needs to be ordered optionally as an accessory.
- ① Please note the minimum permitted bending radii for the sensor cables, which are generally 35 mm.

Analog position sensor

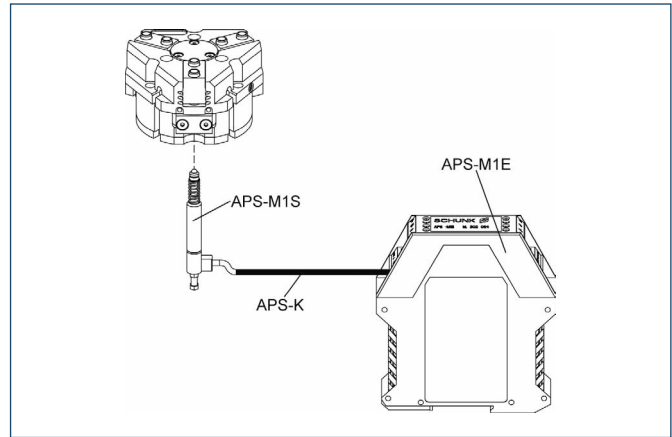

Analog multi position monitoring for any desired positions

Description	ID
Mounting kit	
AS-APS-M1-200/1 and 380/2	0302085
AS-APS-M1-200/2	0302086
Connection cables	
APS-K0200	0302066
APS-K0700	0302068
Electronic Processor	
APS-M1E	0302064
Sensor	
APS-M1S	0302062

- ① When using an APS system, for each gripper a mounting kit (AS-APS), an APS sensor (APS-M 1S, incl. 3 m cable) as well as an electronics (APS-M1e) are required.
- ① An extension cable (APS-K) can be connected between the sensor and the electronics as an option. The max. cable length between the sensor and the electronics is 10 m, between the electronics and their control unit (PLC) it is max. 1 m.

Flexible Position Sensor

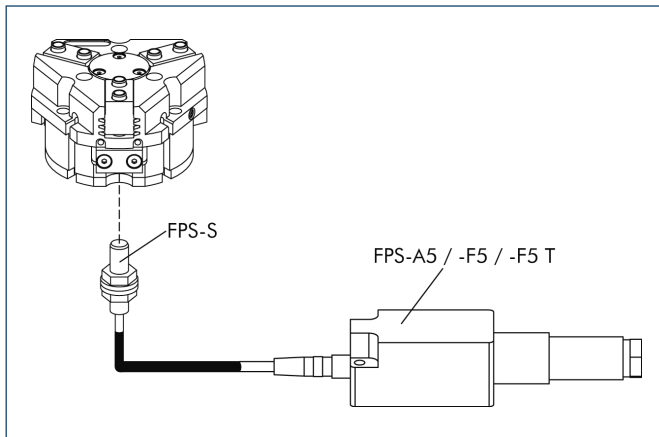

Flexible position monitoring of up to five positions

Description	ID
Mounting kit for FPS	
AS-PGN/PZN-plus 200/1	0301640
AS-PGN/PZN-plus 200/2	0301641
Electronic Processor	
FPS-F5	0301805
FPS-F5 T	0301807
Sensor	
FPS-S M8	0301704

- ① When using a FPS system, a FPS sensor (FPS-S) and a control unit (FPS-F5 / F5 T or A5) are required for each gripper as well as a mounting kit (AS), if listed. Cable extensions (KV) are available as options in the "Accessories" catalog section.



You can find more detailed information and individual parts of the above-mentioned accessories in the "Accessories" catalog section.