

COMPACT[®]
AUTOMATION PRODUCTS

Rotary Actuation Products



Rotary Vane Actuators

Unitized Body

Turn-Act's patented extrusion combines tube, stator and bolt lobes into a one-piece unitized body.

Unique design provides torsional rigidity allowing the unit to stop and hold shaft loads internally, while effectively transmitting shocks to its mountings

Machined Aluminum Heads

Shaft Bearings

Full complement needle bearings accommodate substantial radial loads

Stator

Air Inlets

The large hole permits more rapid air entry and exhaust for faster response time

Bolt Lobe

Rotor Shaft Assembly

Turn-Act's patented rotor/vane assembly eliminates the possibility of shaft rotation in the rotor and permits the use of a wide variety of shaft materials. Output shafts can be custom ordered for specific application requirements

The Gold Seal

Turn-Act's patented polyurethane seal provides smooth rotation, minimal leaks rates, low pressure breakaways and millions of cycles

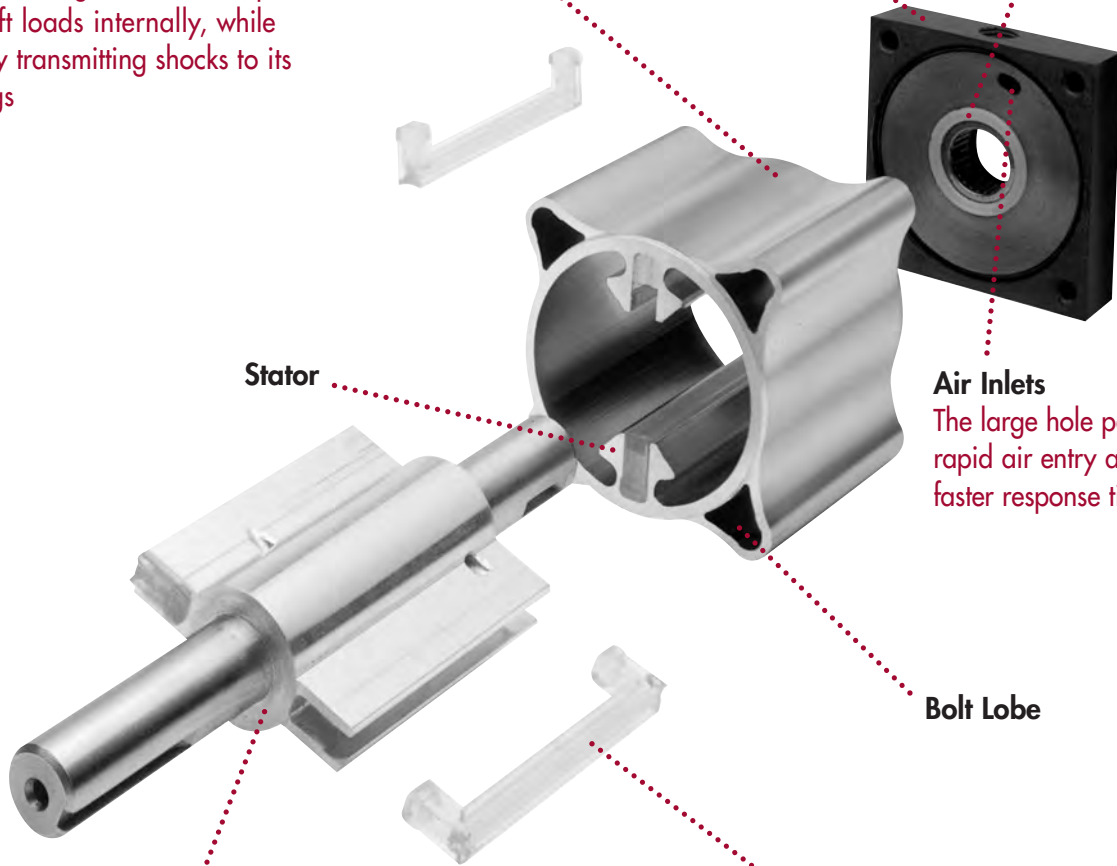

Table of Contents

Compact (CA) Series

| | |
|--------------------|-------|
| Overview | pg. 2 |
| How to Order | pg. 3 |
| Dimensions | pg. 4 |

Turn-Act (TA) Series

| | |
|--------------------|-------|
| Overview | pg. 6 |
| How to Order | pg. 7 |
| Dimensions | pg. 8 |

Brute Series

| | |
|--------------------|--------|
| Overview | pg. 10 |
| How to Order | pg. 11 |
| Dimensions | pg. 12 |

Options

| | |
|---|-----------|
| Actuators for Special Environments | pg. 13 |
| Flange | pg. 14 |
| Combination Flange | pg. 15 |
| Side Angle Mounts | pg. 16 |
| Conveyor Mounting | pg. 17-18 |
| Extended Tie Rods | pg. 19 |
| Side Mounts | pg. 20 |
| Dowel Pin Locator | pg. 21 |
| Three Hole Face Mount and Low Profile Actuators | pg. 22 |
| Adjustable Stroke Control | pg. 23 |
| Thrust Protection | pg. 24 |
| Internal Rotation Stop | pg. 25 |
| Urethane Bumpers | pg. 25 |
| Motion Control Package | pg. 25 |
| Switches | pg. 26-30 |
| Potentiometers & Encoders | pg. 31 |
| Port Locations/Types | pg. 32 |
| Namur Mount | pg. 32 |
| Shaft Modifications | pg. 34-35 |
| Shaft Accessories | pg. 36-37 |
| Three Position Actuator Systems | pg. 38 |
| Hydraulic Service Rotary Actuators | pg. 39 |
| Stainless Steel Actuators | pg. 38 |
| Clean Series | pg. 40 |
| Systems | pg. 41 |

Turn-Dex

| | |
|----------------------------|--------|
| Turn-Dex 1-1/4" Bore | pg. 42 |
| How to Order | pg. 43 |
| Dimensions | pg. 44 |

| | |
|---------------------------------------|--------|
| Turn-Dex 2-1/2" Bore | pg. 45 |
| How to Order | pg. 46 |
| Dimensions | pg. 47 |
| Adjustable Stroke Control (ASC) | pg. 48 |

Turn-Dex Options

| | |
|--------------------------|--------|
| Flange Mount | pg. 49 |
| Side Angle Mounts | pg. 50 |
| Side Mounts | pg. 51 |
| Thrust Protection | pg. 52 |
| Cap Sensor Systems | pg. 53 |
| Trantorque® | pg. 54 |
| Hub Adapter | pg. 55 |

Class Act (CL) Valve Operator

| | |
|----------------------|--------|
| Specifications | pg. 56 |
| How to Order | pg. 57 |

Value-U-Act (VA) Valve Operator

| | |
|----------------------|--------|
| Specifications | pg. 58 |
| How to Order | pg. 59 |

Val-U-Act (VS) Spring Return

| | |
|--------------------|--------|
| How to Order | pg. 60 |
|--------------------|--------|

| | |
|--------------------------|--------|
| Warranty Statement | pg. 62 |
|--------------------------|--------|

Comp-Act (CA) Series

ROTARY VANE ACTUATORS:

- 15 base models with torque outputs from 9 in. lbs. to 100 in. lbs.
- Rotations 90, 180 & 270 degrees.

As compared to other rotary devices... Turn-Act Vane Actuators have:

- One moving part providing:
 - ZERO Backlash.
 - No loss of motion.
 - Smooth Rotation.
 - Precise Repeatability.
 - Continuous full torque throughout rotation.
- Turn-Act Patented Urethane seals for:
 - Long cycle life and Non-lube service.
 - Actual applications with 25 million cycles and more.
- 100s of standard options and modifications.

Just imagine... How TURN-ACT Answer Engineering can work for you!



COMP-ACT ACTUATOR
WITH OPTIONAL ADJUSTABLE
STROKE CONTROL

| Torque Chart (IN. LBS.) | | | |
|--------------------------------------|--------------------|--------|--------|
| 180° and 270° Rotations ² | | | |
| Actuator Model | Actuator Torque at | | |
| | 100 PSI | 80 PSI | 60 PSI |
| 011 (270°) | 9 | 7 | 5 |
| 013 (180°) | | | |
| 021 (270°) | 13 | 10 | 8 |
| 023 (180°) | | | |
| 031 (270°) | 25 | 20 | 15 |
| 033 (180°) | | | |
| 041 (270°) | 32 | 26 | 19 |
| 043 (180°) | | | |
| 061 (270°) | 50 | 40 | 30 |
| 063 (180°) | | | |

| Torque Chart (IN. LBS.) | | | |
|----------------------------|--------------------|--------|--------|
| 90° Rotations ² | | | |
| Actuator Model | Actuator Torque at | | |
| | 100 PSI | 80 PSI | 60 PSI |
| 012 | 17 | 14 | 10 |
| 022 | 25 | 20 | 15 |
| 032 | 44 | 35 | 26 |
| 042 | 60 | 48 | 36 |
| 062 | 100 | 80 | 60 |

SPECIFICATIONS

Unit Materials

Stator/Rotor Seals... Urethane
 Shaft/Tube Seals..... Buna¹
 Shaft..... 303 Stainless Steel
 Body..... Anodized Alum.
 Bearings..... Full Comp. Needle

Miscellaneous

Inlets 1/8 NPT
 Min. Pressure 35 psi
 Max. Pressure 200 psi
 Cylinder Bore 1-1/4"

Shaft Load Capacities

Max. Side Load..... 250 lbs.
 Max. End Load..... 10 lbs.

Temperature Range

40°F to 180°F
 For applications below 40°F, a variety of seal options are available based upon cycle rates, temperatures and frequency of use. Consult the factory to discuss your cold temperature application for your optimum solution.

Filtration

Air..... 25-50 microns

Cycle Rates³

Max. non-lubed rate:
 90° Rot..... 40 cpm
 180°, 270° Rot..... 20 cpm

Max. lubed rate:
 Consult Factory

Rotary Motion Backlash
 All models 0 degree

Leak Rates

Air..... 4 cfm or less @ 100 psi

- 1 Viton Optional
- 2 All rotations are nominal +4/-0 actual
- 3 Cycle = Start position to end of rotation and returning to the start position.
Stroke = 1/2 cycle

| Capacity per Stroke ³ (IN ³) | | | |
|---|------|---------------------------|------|
| 270° Rotation ² | | 90° Rotation ² | |
| 011 | 0.50 | 012 | 0.42 |
| 021 | 0.99 | 022 | 0.84 |
| 031 | 1.49 | 032 | 1.26 |
| 041 | 1.99 | 042 | 1.68 |
| 061 | 3.49 | 062 | 2.96 |

| Weights (OZs) | | | |
|----------------------------|----|---------------------------|----|
| 270° Rotation ² | | 90° Rotation ² | |
| 011 | 8 | 012 | 8 |
| 021 | 10 | 022 | 10 |
| 031 | 12 | 032 | 12 |
| 041 | 14 | 042 | 14 |
| 061 | 18 | 062 | 18 |

How to Order: Comp-Act (CA)

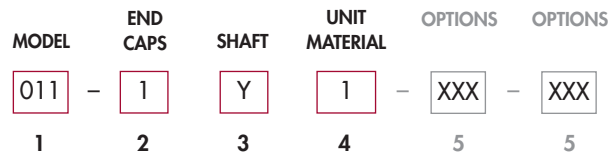

1

| Model | | | |
|-------|--------|--------|----------|
| Model | Series | Torque | Rotation |
| 011 | CA | 09 | 270 |
| 012 | CA | 17 | 90 |
| 013 | CA | 09 | 180 |
| 021 | CA | 13 | 270 |
| 022 | CA | 25 | 90 |
| 023 | CA | 13 | 180 |
| 031 | CA | 25 | 270 |
| 032 | CA | 44 | 90 |
| 033 | CA | 25 | 180 |
| 041 | CA | 32 | 270 |
| 042 | CA | 60 | 90 |
| 043 | CA | 32 | 180 |
| 061 | CA | 50 | 270 |
| 062 | CA | 100 | 90 |
| 063 | CA | 50 | 180 |

2

| End Caps | |
|---|-----------------------------|
| To Specify other modifications; Consult Factory | |
| 1 | Pneumatic |
| 2 | Pneumatic - Low Profile |
| 4 | Pneumatic - w/ Vacuum Ports |

3

| Shaft | |
|---|------------------------------------|
| To Specify other modifications; Consult Factory | |
| Y | Single End - No Keyway |
| M | Double End - No Keyway Each End |
| W | Single End - Woodruff Key |
| V | Double End - Woodruff Key Each End |
| U | Single End - Shaft Flat |
| T | Double End - Shaft Flat Each End |
| S | Single End - Keyway |
| R | Double End - Keyway Each End |

4

| Unit Materials | |
|---------------------|---|
| Shaft - Body - Trim | |
| 1 | 303 Stainless Steel - Anodized Aluminum - Carbon Steel |
| 3 | 303 Stainless Steel - Anodized Aluminum - Stainless Steel |
| 4 | 303 Stainless Steel - Stainless Steel - Stainless Steel |
| 6 | 316 Stainless Steel - 316 Stainless Steel - Stainless Steel |

5

| Options | |
|---|--|
| Additional options available on pgs. 14-33 | |
| 000 | No Options |
| 100 | Flange Mount - Rod End |
| 101 | Flange Mount - Cap End |
| 300 | Extended Tie Rods - Rod End |
| 301 | Extended Tie Rods - Cap End |
| 400 | Adjustable Stroke Control - Cap End, Pos.5 |
| 401 | Adjustable Stroke Control - Rod End, Pos.1 |
| 801 | Side Mounts - Positions 2 & 6 |
| 803 | Side Mounts - Positions 4 & 8 |
| 804 | Side Mounts - Positions 2,4,6 & 8 |
| 900 | Thrust Protection - Cap End, Pos.1 |
| 901 | Thrust Protection - Rod End, Pos.1 |
| B00 | Urethane Bumpers |
| T01 | 3/8" Trantorque® Shaft Coupler - Carbon Steel |
| T02 | 3/8" Trantorque® Shaft Coupler - Stainless Steel Stainless Shaft Coupler has 1/3 the Transmissible Torque as T01 (see pgs. 34-35) |
| Switch Options | |
| Additional switch options available on pg. 24 | |
| All Axx Switch Options are Single End Only | |
| A00 | Switch Package - No Switches |
| A02 | Switch Pkg. - 2 Reed Switches |
| A05 | Switch Pkg. - 2 Sourcing Switches |
| A08 | Switch Pkg. - 2 Sinking Switches |
| Double end switch options available on pgs. 25-26 | |

Dimensional Data: Comp-Act (CA)

Basic Dimensions

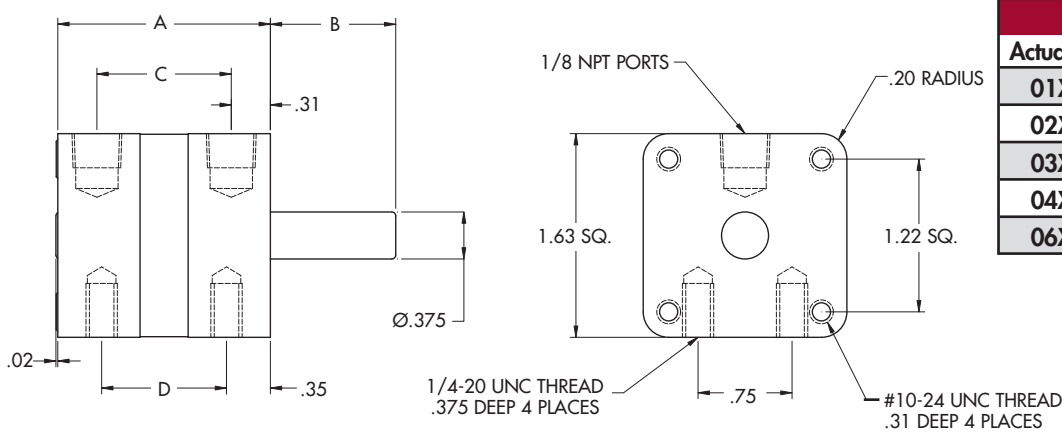

| Dimensional Specifications | | | | |
|----------------------------|------|------|------|------|
| Actuator | A | B | C | D |
| 01X | 1.70 | 1.00 | 1.07 | 1.00 |
| 02X | 2.20 | 1.00 | 1.57 | 1.50 |
| 03X | 2.70 | 1.00 | 2.07 | 2.00 |
| 04X | 3.20 | 1.00 | 2.57 | 2.50 |
| 06X | 4.75 | 1.00 | 4.12 | 4.05 |

Shaft Options

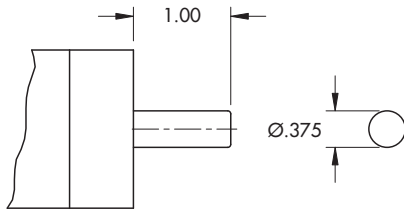

Basic Shaft

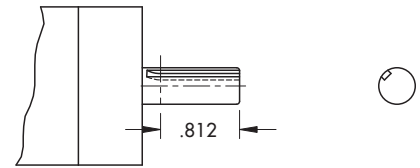

$3/32$ " Square Keyway

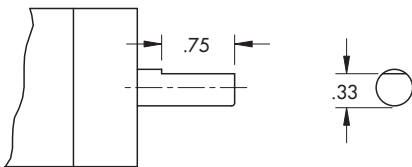

Shaft Flat

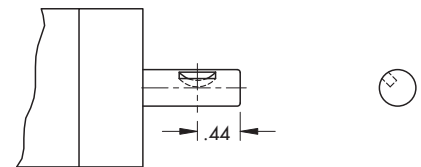

#303 Woodruff Key

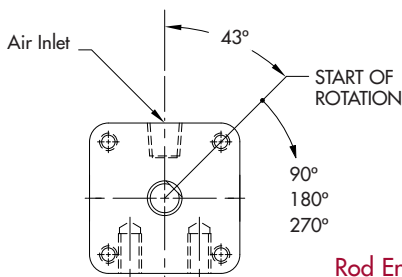

Rod End View

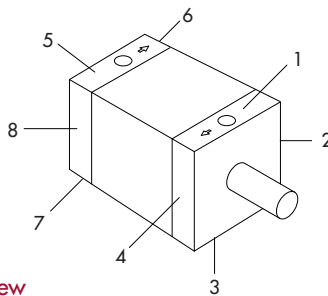

Port & Mounting Position References

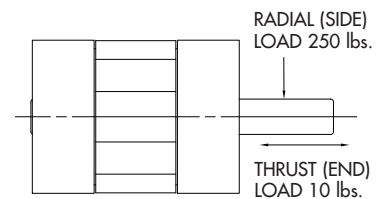

Shaft Load Capacity

NOTE: The 43° start position is nominal. Tolerances are ± 2 degrees.

Can You Imagine...

ANSWER ENGINEERING®

The ability to rapidly and accurately modify our products to better meet the requirements of your application.

Frequently, a simple modification; a shorter shaft, a relocated mounting hole or perhaps a change in port size, results in an actuator that will better fit your application. To modify most other manufacturers products is time consuming and expensive. Turn-Act's manufacturing processes are designed to address rapid, accurate, and cost effective production of custom modified rotary actuators.



Imagine... Clean Room Application

To address the demanding requirements of a clean room application, Turn-Act designed and produced a Conveyor stop sub-assembly.

This assembly consists of:

- 60 in. lbs. 90° rotary actuator
- An adjustable mounting bracket designed to integrate with the conveyor rail
- Stop Arm
- Trantorque™ shaft coupling
- Arm end-effector to interface with conveyed product

The purchase of this sub-assembly resulted in cost reductions for the customer by eliminating and minimizing:

- Design costs
- Fabrication costs
- Assembly/Install costs
- Inventory costs

THIS IS... Turn-Act Answer Engineering®

Imagine... Medical Application

To contend with the repeatability and space constraints of a small desktop medical analysis device, Turn-Act designed and produced this SPECIAL Actuator Assembly.

This assembly consists of:

- 60 in. lbs. 90° rotary actuator
- Combined rod head and flange mount
- Shaft modification included:
 - Extended length
 - Turn down
 - Threaded end
 - Cross drilled hole
 - Assembly of a shaft bushing and cross pin
- Special switch system and connectors
- Preset adjustable stroke control

Cost reduction is always a priority, however this application had the additional constraints of size and a need for 100% repeatability. Turn-Act provided a product that met all of these requirements.

THIS IS... Turn-Act Answer Engineering®

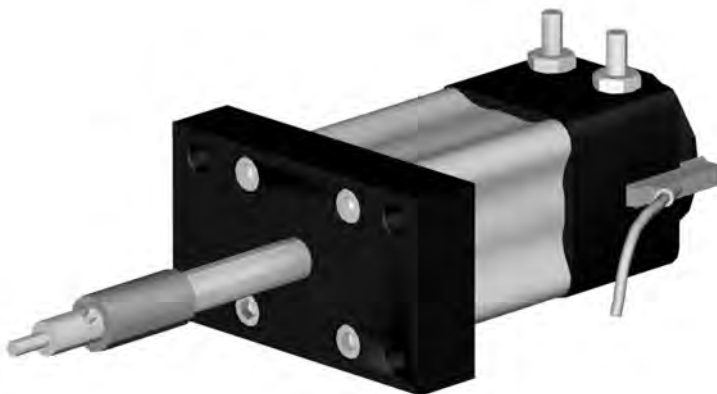

Turn-Act® (TA) Series

ROTARY VANE ACTUATORS:

- 16 base models with torque outputs from 87 in. lbs. to 1000 in. lbs.
- Rotations 45, 90, 180 & 270 degrees.

As compared to other rotary devices... Turn-Act Vane Actuators have:

- One moving part providing:
 - ZERO Backlash.
 - No loss of motion.
 - Smooth Rotation.
 - Precise Repeatability.
 - Continuous full torque throughout the rotation.
- Patented Urethane seals for:
 - Long cycle life and Non-lube service.
 - Actual applications with 25 million cycles and more.
- 100s of standard options and modifications.

Just imagine... How TURN-ACT Answer Engineering can work for you!

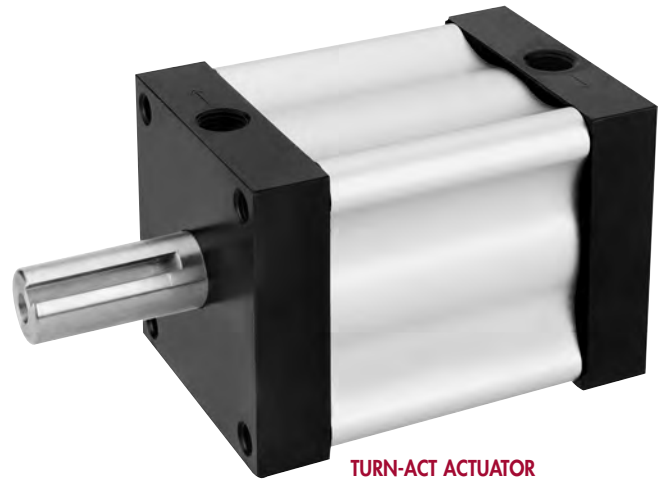

TURN-ACT ACTUATOR
NO OPTIONS SELECTED

| Torque Chart (IN. LBS.) | | | |
|--------------------------------------|--------------------|--------|--------|
| 180° and 270° Rotations ² | | | |
| Actuator Model | Actuator Torque at | | |
| | 100 PSI | 80 PSI | 60 PSI |
| 111 (270°) | 87 | 70 | 52 |
| 113 (180°) | | | |
| 121 (270°) | 175 | 140 | 105 |
| 123 (180°) | | | |
| 131 (270°) | 350 | 280 | 210 |
| 133 (180°) | | | |
| 141 (270°) | 500 | 400 | 300 |
| 143 (180°) | | | |

| Torque Chart (IN. LBS.) | | | |
|------------------------------------|--------------------|--------|--------|
| 45° AND 90° Rotations ² | | | |
| Actuator Model | Actuator Torque at | | |
| | 100 PSI | 80 PSI | 60 PSI |
| 112 (90°) | 175 | 140 | 105 |
| 114 (45°) | | | |
| 122 (90°) | 350 | 280 | 210 |
| 124 (45°) | | | |
| 132 (90°) | 700 | 560 | 420 |
| 134 (45°) | | | |
| 142 (90°) | 1000 | 800 | 600 |
| 144 (45°) | | | |

SPECIFICATIONS

Unit Materials

Stator/Rotor Seals...Urethane
 Shaft/Tube Seals.....Buna¹
 Shaft.....Polished & Ground,
 Fatigue Proof 1144
 Body.....Anodized Alum.
 Bearings....Full Comp. Needle

Miscellaneous

Inlets.....1/4 NPT
 Min. Pressure35 psi
 Max. Pressure200 psi⁴
 Cylinder Bore.....2-1/2"

Shaft Load Capacities

Max. Side Load.....500 lbs.
 Max. End Load.....25 lbs.

Temperature Range

40°F to 180°F
 For applications below 40°F, a variety of seal options are available based upon cycle rates, temperatures and frequency of use. Consult the factory to discuss your cold temperature application for your optimum solution.

Filtration

Air.....25-50 microns
 Hydraulic.....10-25 microns

Cycle Rates

Max. non-lubed rate:
 45°, 90° Rot.....40 cpm
 180°, 270° Rot.....20 cpm

Max. lubed rate:
 Consult Factory

Rotary Motion Backlash

All models0 degree

Leak Rates

Air.....4 cfm or less @ 100 psi
 Hydraulic..0.5 cim @ 500 psi

Hydraulic Service

Available for 11x and 12x size Turn-Act rotaries only. Use of paraffin based hydraulic oil is recommended. DO NOT USE skydrol, brake fluid, water based fluid, S or F type automatic transmission fluid.

- 1 Viton Optional
- 2 All rotations are nominal +4/-0 actual
- 3 Cycle = Start position to end of rotation and returning to the start position.
Stroke = 1/2 cycle
- 4 Pressure Rating for 11X and 12X is 500psi max.

| Capacity per Stroke ³ (IN ³) | | | |
|---|-------|---------------------------|-------|
| 270° Rotation ² | | 90° Rotation ² | |
| 111 | 4.52 | 112 | 2.75 |
| 121 | 8.50 | 122 | 5.50 |
| 131 | 17.00 | 132 | 11.00 |
| 141 | 27.50 | 142 | 16.70 |

| Weights (LBS.) | | | |
|----------------------------|-----|---------------------------|-----|
| 270° Rotation ² | | 90° Rotation ² | |
| 111 | 2.5 | 112 | 2.5 |
| 121 | 3.3 | 122 | 3.3 |
| 131 | 6.0 | 132 | 6.0 |
| 141 | 9.3 | 142 | 9.3 |

How to Order: Turn-Act® (TA)

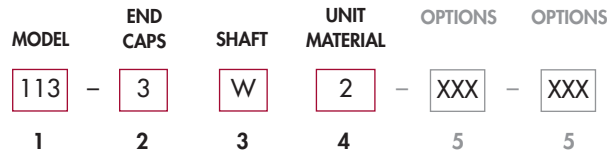

1 Model

| Model | Series | Torque | Rotation |
|-------|--------|--------|----------|
| 111 | TA | 87 | 270 |
| 112 | TA | 175 | 90 |
| 113 | TA | 87 | 180 |
| 114 | TA | 175 | 45 |
| 121 | TA | 175 | 270 |
| 122 | TA | 350 | 90 |
| 123 | TA | 175 | 180 |
| 124 | TA | 350 | 45 |
| 131 | TA | 350 | 270 |
| 132 | TA | 700 | 90 |
| 133 | TA | 350 | 180 |
| 134 | TA | 700 | 45 |
| 141* | TA | 500 | 270 |
| 142* | TA | 1000 | 90 |
| 143* | TA | 500 | 180 |
| 144* | TA | 1000 | 45 |

* These models require '2' or '5' for the selection in block #4 "Unit Materials".

2 End Caps
To Specify other modifications; Consult Factory

| | |
|---|-----------------------------|
| 1 | Pneumatic |
| 2 | Pneumatic - Low Profile |
| 3 | Hydraulic - w/ Drain Ports |
| 4 | Pneumatic - w/ Vacuum Ports |

3 Shaft
To Specify other modifications; Consult Factory

| | |
|---|------------------------------------|
| Y | Single End - No Keyway |
| M | Double End - No Keyway Each End |
| W | Single End - Woodruff Key |
| V | Double End - Woodruff Key Each End |
| U | Single End - Shaft Flat |
| T | Double End - Shaft Flat Each End |
| S | Single End - Keyway |
| R | Double End - Keyway Each End |
| G | Single End With Manual Override |

4 Unit Materials
Shaft - Body - Trim

| | |
|---|--|
| 1 | Polished & Ground Fatigue Proof 1144 Steel - Anodized Aluminum - Carbon Steel |
| 2 | Hardened Carbon Steel - Anodized Aluminum - Carbon Steel |
| 3 | 303 Stainless Steel - Anodized Aluminum - Stainless Steel |
| 4 | 303 Stainless Steel - 303 Stainless Steel - Stainless Steel |
| 5 | Hardened 440 SS - Anodized Aluminum - Stainless Steel |
| 6 | 316 Stainless Steel - 316 Stainless Steel - Stainless Steel |

5 Options
Additional options available on pgs. 14-33

| | |
|--|--|
| 000 | No Options |
| 100 | Flange Mount - Rod End |
| 101 | Flange Mount - Cap End |
| 200 | Side Angle Mounting Brackets - Mounting Surface 3 & 7 |
| 300 | Extended Tie Rods - Rod End |
| 301 | Extended Tie Rods - Cap End |
| 320 | Extended Tie Rods - Both Ends |
| 400 | Adjustable Stroke Control - Cap End, Pos.5 |
| 401 | Adjustable Stroke Control - Rod End, Pos.1 |
| 500 | Electrical Position Indicator - Cap End, Pos. 5 |
| 704 | Teflon Impregnated Hard Anodized |
| 801 | Side Mounts - Positions 2 & 6 |
| 803 | Side Mounts - Positions 4 & 8 |
| 804 | Side Mounts - Positions 2, 4, 6 & 8 |
| 900 | Thrust Protection - Cap End, Pos.1 |
| 901 | Thrust Protection - Rod End, Pos.1 |
| B00 | Urethane Bumpers |
| T01 | 3/4" Trantorque® Shaft Coupler - Carbon Steel |
| T02 | 3/4" Trantorque® Shaft Coupler - Stainless Steel Stainless Shaft Coupler has 1/3 the Transmissible Torque as T01 (see pgs. 34-35) |
| Switch Options Additional switch options available on pg. 24 All Axx Switch Options are Single End Only | |
| A00 | Switch System -No Switches |
| A02 | Switch System -2 Reed Switches |
| A05 | Switch System -2 Sourcing Switches |
| A08 | Switch System -2 Sinking Switches |
| Double end switch options available on pgs. 25-26 | |

Dimensional Data: Turn-Act® (TA)

Basic Dimensions

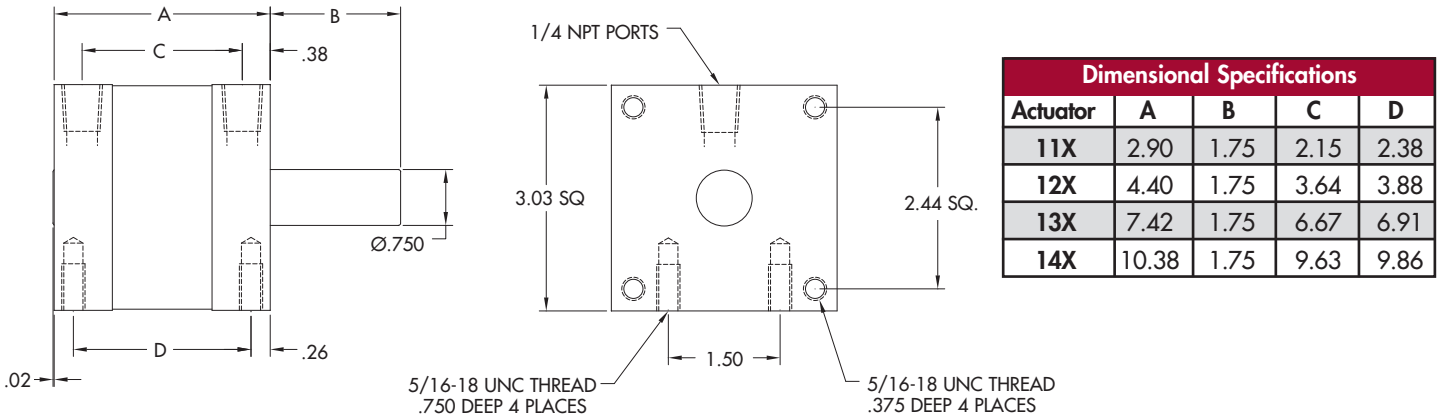

Shaft Options

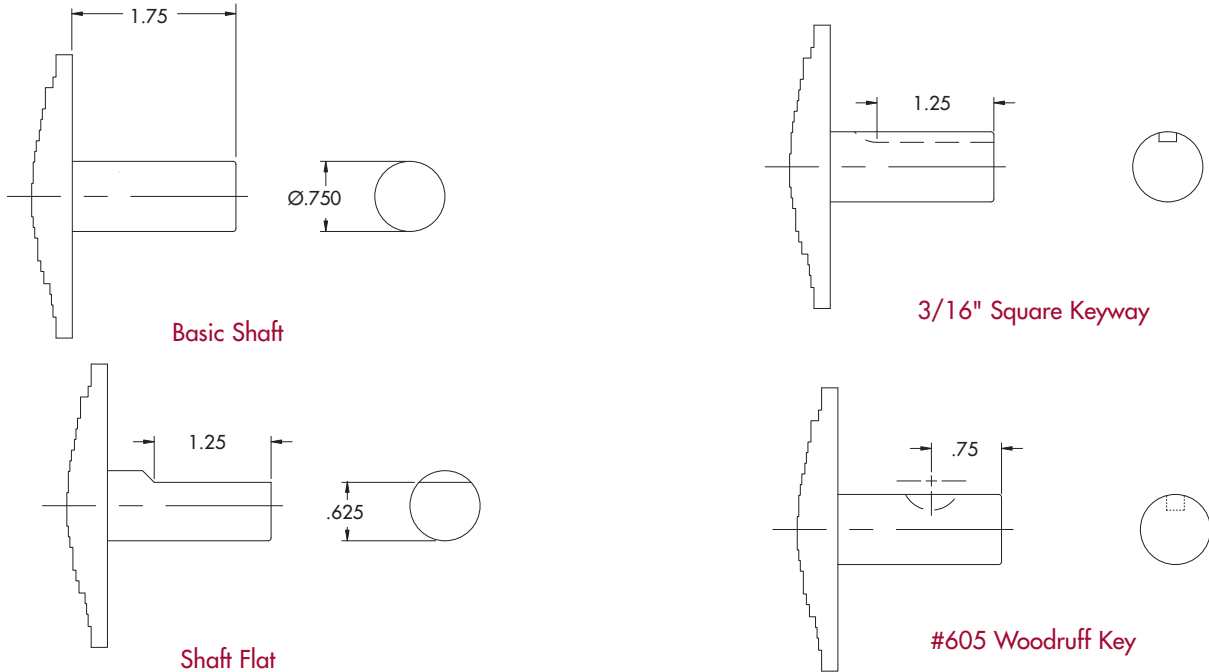

NOTE: Center drill omitted from shaft details for clarity.

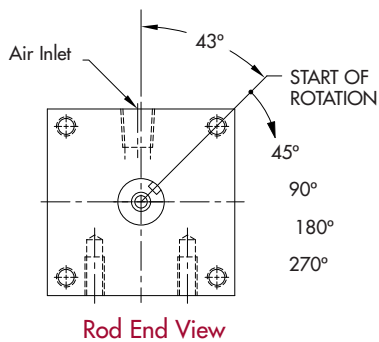

Nominal Rotations (+4/-0 actual)

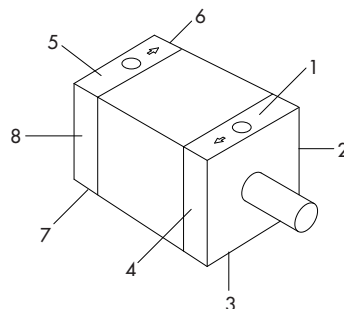

Port & Mounting Position References

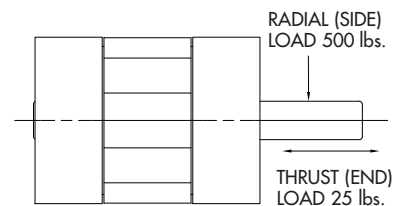

Shaft Load Capacity

NOTE: The 43° start position is nominal. Tolerances are +/- 2 degrees.

Can You Imagine...

ANSWER ENGINEERING®

The ability to rapidly and accurately modify our products to better meet the requirements of your application.

Frequently, a simple modification; a shorter shaft, a relocated mounting hole or perhaps a change in port size, results in an actuator that will better fit your application. To modify most other manufacturers products is time consuming and expensive. Turn-Act's manufacturing processes are designed to address rapid, accurate, and cost effective production of custom modified rotary actuators.

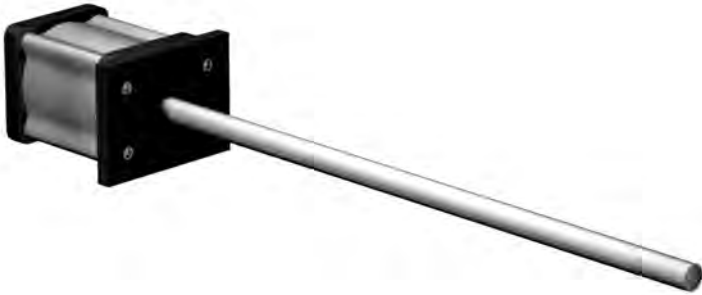

Imagine... Product Transfer Application

Consistent around the clock throughput is critical to a profitable plastics molding operation. Turn-act developed this SPECIAL Actuator to meet the needs of the high speed mold sweep application.

This unit consists of:

- 2600 in. lbs. 110° rotation
- Shaft modification:
 - 33" Extended length

Long cycle life, repeatability, and cost per cycle are the prime considerations of this modified actuator. The simple shaft extension allowed the elimination of a secondary shaft, shaft coupling, shaft bearing and brackets. Fewer component parts produced a more reliable and repeatable system while reducing the final installed cost.

THIS IS... Turn-Act Answer Engineering®



Imagine... Abrasive/High Particulate Environment

Some of the most abusive environments can be found in the paper, wood products, bakery, and foundry industries. Migrating particulates can be the cause of premature equipment failure in these applications.

To address these environmental issues, Turn-Act developed this SPECIAL Actuator.

This assembly consists of:

- 175 in. lbs. 90° rotary actuator
- Shaft modification included:
 - 6" Extended length with a 1.5" flat
 - Tapped holes for end effector attachment
- Rod Seal – modified for abusive environments
- Blind cap head

Improved actuator life and system cost reductions were the primary goals of this modified actuator. Overall, the design provided extended cycle life by limiting particulate entry points and reduced costs associated with assembling the components.

THIS IS... Turn-Act Answer Engineering®

Brute (BR) Series

ROTARY VANE ACTUATORS:

- 25 base models with torque outputs from 400 in. lbs to 5200 in. lbs.
- Standard rotations 90, 110, 180, 270, & 290 degrees.

As compared to other rotary devices... Turn-Act Vane Actuators have:

- One moving part providing:
 - ZERO Backlash.
 - No loss of motion.
 - Smooth Rotation.
 - Precise repeatability.
 - Continuous full torque throughout the rotation.
- Patented Urethane seals for:
 - Long cycle life and Non-Lube service.
 - Actual applications with 25 million cycles and more.
- 100s of standard options and modifications.

Just imagine... How TURN-ACT Answer Engineering can work for you!



**BRUTE SERIES ACTUATOR
WITH OPTIONAL ADJUSTABLE
STROKE CONTROL**

| Torque Chart (IN. LBS.) | | | |
|--|--------------------|--------|--------|
| 180°, 270° and 290° Rotations ² | | | |
| Actuator Model | Actuator Torque at | | |
| | 100 PSI | 80 PSI | 60 PSI |
| 221 (270°) | 400 | 320 | 240 |
| 223 (180°) | | | |
| 225 (290°) | | | |
| 231 (270°) | 750 | 600 | 450 |
| 233 (180°) | | | |
| 235 (290°) | | | |
| 241 (270°) | 1300 | 1040 | 780 |
| 243 (180°) | | | |
| 245 (290°) | | | |
| 251 (270°) | 1950 | 1560 | 1170 |
| 253 (180°) | | | |
| 255 (290°) | | | |
| 261 (270°) | 2600 | 2080 | 1560 |
| 263 (180°) | | | |
| 265 (290°) | | | |

| Torque Chart (IN. LBS.) | | | |
|-------------------------------------|--------------------|--------|--------|
| 90° and 110° Rotations ² | | | |
| Actuator Model | Actuator Torque at | | |
| | 100 PSI | 80 PSI | 60 PSI |
| 222 (90°) | 800 | 640 | 480 |
| 226 (110°) | | | |
| 232 (90°) | 1500 | 1200 | 900 |
| 236 (110°) | | | |
| 242 (90°) | 2600 | 2080 | 1560 |
| 246 (110°) | | | |
| 252 (90°) | 3900 | 3120 | 2340 |
| 256 (110°) | | | |
| 262 (90°) | 5200 | 4160 | 3120 |
| 266 (110°) | | | |

SPECIFICATIONS

Unit Materials

Stator/Rotor Seals...Urethane
 Shaft/Tube Seals.....Buna¹
 Shaft.....Polished & Ground
 Fatigue Proof 1144
 Body..... Anodized Alum.
 Bearings....Radial Ball Thrust

Miscellaneous

Inlets.....3/8 NPT
 Min. Pressure15 psi
 Max. Pressure200 psi
 Cylinder Bore5"

Shaft Load Capacities

Max. Side Load.....2000 lbs.
 Max. End Load.....1000 lbs.

Temperature Range

40°F to 180°F
 For applications below 40°F, a variety of seal options are available based upon cycle rates, temperatures and frequency of use. Consult the factory to discuss your cold temperature application for your optimum solution.

Filtration

Air.....25-50 microns
 Hydraulic.....10-25 microns

Leak Rates

Air...less than 8 cfh@100 psi

Cycle Rates

Max. non-lubed rate:
 Double Vane.....20 cpm
 Single Vane.....10 cpm

Max. lubed rate:
 Consult Factory

Rotary Motion Backlash

All models.....0 degree

- 1 Viton Optional.
- 2 All rotations are nominal +4/-0 actual.
- 3 Cycle = Start position to end of rotation, and returning to the start position.
Stroke = 1/2 cycle

| Capacity per Stroke ³ (IN ³) | | | |
|---|-------|---------------------------|-------|
| 270° Rotation ² | | 90° Rotation ² | |
| 221 | 23.9 | 222 | 19.3 |
| 231 | 48.5 | 232 | 38.5 |
| 241 | 82.0 | 242 | 66.0 |
| 251 | 123.0 | 252 | 100.0 |
| 261 | 164.0 | 262 | 132.0 |

| Weights (LBS.) | | | |
|----------------------------|----|---------------------------|----|
| 270° Rotation ² | | 90° Rotation ² | |
| 221 | 13 | 222 | 13 |
| 231 | 16 | 232 | 16 |
| 241 | 23 | 242 | 23 |
| 251 | 30 | 252 | 30 |
| 261 | 36 | 262 | 36 |

How to Order: Brute (BR)

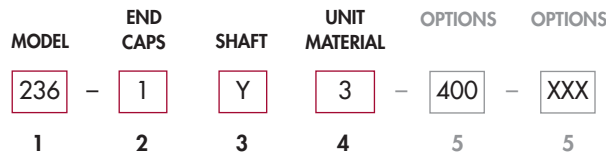

1

| Model | | | |
|-------|--------|--------|----------|
| Model | Series | Torque | Rotation |
| 221 | BR | 400 | 270 |
| 222 | BR | 800 | 90 |
| 223 | BR | 400 | 180 |
| 225 | BR | 400 | 290 |
| 226 | BR | 800 | 110 |
| 231 | BR | 750 | 270 |
| 232 | BR | 1500 | 90 |
| 233 | BR | 750 | 180 |
| 235 | BR | 750 | 290 |
| 236 | BR | 1500 | 110 |
| 241 | BR | 1300 | 270 |
| 242 | BR | 2600 | 90 |
| 243 | BR | 1300 | 180 |
| 245 | BR | 1300 | 290 |
| 246 | BR | 2600 | 110 |
| 251 | BR | 1950 | 270 |
| 252 | BR | 3900 | 90 |
| 253 | BR | 1950 | 180 |
| 255 | BR | 1950 | 290 |
| 256 | BR | 3900 | 110 |
| 261 | BR | 2600 | 270 |
| 262 | BR | 5200 | 90 |
| 263 | BR | 2600 | 180 |
| 265 | BR | 2600 | 290 |
| 266 | BR | 5200 | 110 |

2

| End Caps | |
|---|--|
| To Specify other modifications; Consult Factory | |
| 1 | Pneumatic - Black Anodized |
| 4 | Pneumatic - Black Anodized - Vacuum Port |

3

| Shaft | |
|---|------------------------------------|
| To Specify other modifications; Consult Factory | |
| Y | Single End - No Keyway |
| M | Double End - No Keyway Each End |
| W | Single End - Woodruff Key |
| V | Double End - Woodruff Key Each End |
| S | Single End - Keyway |
| R | Double End - Keyway Each End |

4

| Unit Materials | |
|---------------------|--|
| Shaft - Body - Trim | |
| 1 | Polished & Ground Fatigue Proof 1144 Steel - Anodized Aluminum - Carbon Steel |
| 3 | 303 Stainless Steel - Anodized Aluminum - Stainless Steel |
| 4 | 303 Stainless Steel - 303 Stainless Steel - Stainless Steel |
| 6 | 316 Stainless Steel - 316 Stainless Steel - Stainless Steel |

5

| Options | |
|---|---|
| Additional options available on pgs. 14-33 | |
| 000 | No Options |
| 100 | Flange Mount - Rod End |
| 101 | Flange Mount - Cap End |
| 300 | Extended Tie Rods - Rod End |
| 301 | Extended Tie Rods - Cap End |
| 401 | Adjustable Stroke Control - Rod End, Pos. 1 |
| 501 | Electrical Position Indicator - Rod End, Pos. 1 |
| 704 | Teflon Impregnated Hard Anodizing |
| 801 | Side Mounts - Positions 2 & 6 |
| 803 | Side Mounts - Positions 4 & 8 |
| 804 | Side Mounts - Positions 2,4,6 & 8 |
| B00 | Urethane Bumpers |
| T01 | 1-1/4" Trantorque® Shaft Coupler - Carbon Steel |
| T02 | 1-1/4" Trantorque® Shaft Coupler - Stainless Steel <small>Stainless Shaft Coupler has 1/3 the Transmissible Torque as T01 (see pgs. 34-35)</small> |
| Switch Options | |
| Additional switch options available on pg. 24 | |
| All Axx Switch Options are Single End Only | |
| A00 | Switch Package - No Switches |
| A02 | Switch Pkg. - 2 Reed Switches |
| A05 | Switch Pkg. - 2 Sourcing Switches |
| A08 | Switch Pkg. - 2 Sinking Switches |
| Double end switch options available on pgs. 25-26 | |

Dimensional Data: Brute (BR) Series

BRUTE (BR) Series

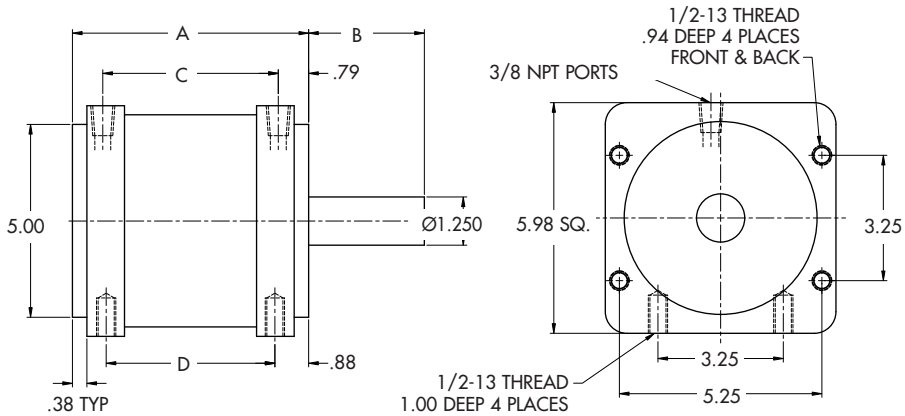

| Dimensional Specifications | | | | |
|----------------------------|-------|------|-------|-------|
| Actuator | A | B | C | D |
| 22X | 4.37 | 3.00 | 2.80 | 2.62 |
| 23X | 6.12 | 3.00 | 4.55 | 4.37 |
| 24X | 8.62 | 3.00 | 7.05 | 6.87 |
| 25X | 11.64 | 3.00 | 10.07 | 9.89 |
| 26X | 14.64 | 3.00 | 13.07 | 12.89 |

SHAFT OPTIONS

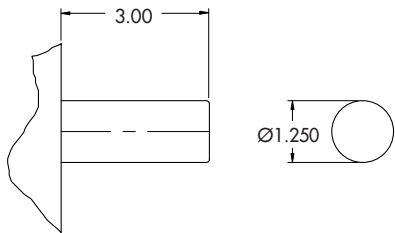

Basic Shaft

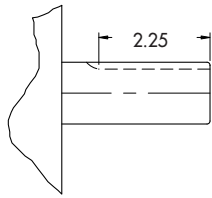

1/4" Square Keyway

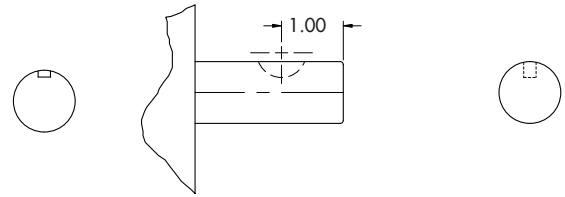

#808 Woodruff Key

NOTE: Center drill omitted from shaft details for clarity.

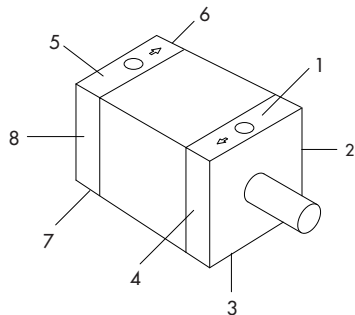

Port & Mounting Position References

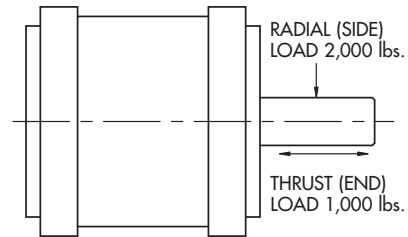

Shaft Load Capacity

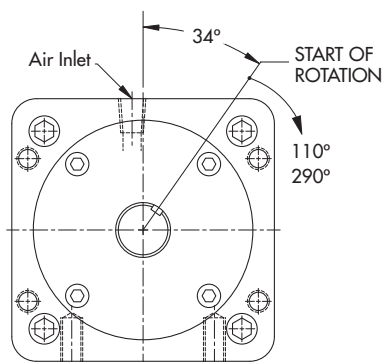

Nominal Rotations (+4/-0 actual)

Rod End Views

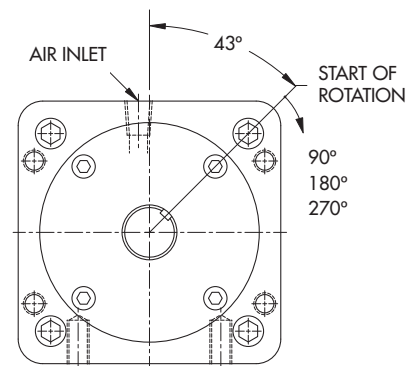

Nominal Rotations (+4/-0 actual)

NOTE: The 34° and 43° start position are nominal. Tolerances are +/- 2 degrees.

Can You Imagine...

ANSWER ENGINEERING®

The ability to rapidly and accurately modify our products to better meet the requirements of your application.

Frequently, a simple modification; a shorter shaft, a relocated mounting hole or perhaps a change in port size, results in an actuator that will better fit your application. To modify most other manufacturers products is time consuming and expensive. Turn-Act's manufacturing processes are designed to address rapid, accurate, and cost effective production of custom modified rotary actuators.



Imagine... Food Process/Washdown Application

Food contact and caustic wash down are some of the parameters that must be addressed when designing machinery for the food industry. Turn-Act developed this Special Actuator for this type of manufacturing environment.

This unit consists of:

- 2600 in. lbs. 180° rotation
- Stainless shaft and fasteners
- Heads sealed for wash down
- Shaft modification included:
 - Double end, extended length with ground tolerances to run in an external bearing set.
- Teflon® impregnated hard anodizing for caustic washdown

Improved actuator life and system cost reductions were the primary goals of this modified actuator. Overall, the design provided extended cycle life by limiting wash fluid entry points and reduced costs associated with assembling the components.

Actuators for Special Environments

As standard Turn-Act Actuators are designed for most industrial environments. However food service, clean room, (medical and semi conductor) and other environments where the units will be subjected to frequent wash down, often with caustic solutions may require special modification.

Modifications available are:

- Shaft quad seals in lieu of standard "o" rings
- Viton seals
- Stainless steel shaft and fasteners
- Blind cap heads
- Blind and sealed Adjustable Stroke Control

- Exterior coatings:
 - Teflon impregnated hard anodized surface meets FDA & USDA requirements for use in caustic and clean room environments.
 - Epoxy – consult factory for specific coating, cost and delivery
 - Nickel Plated – consult factory for cost and delivery
- Exterior Materials:
 - Full Stainless Steel (303 & 316) Body Actuators.
 - The patented Turn-Act tube is produced in stainless steel to meet specific application requirements.

These modifications can be varied for specific application needs.

Consult the factory for specific ordering information.
Clean Room & Systems Options on Pages 40-41



TEFLON IMPREGNATED ANODIZING



EPOXY COATED



FULL STAINLESS STEEL BODY



Options – Flange Mount

COMP-ACT (CA) Series

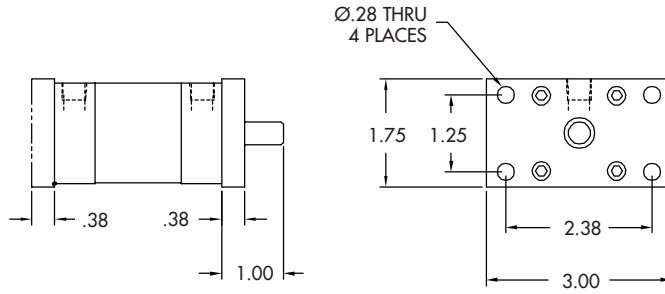

NOTE: Side Mounts surface 3 & 7 are standard, but are not shown for clarity. Standard Bottom Mount dimensions shown on page 4.

TURN-ACT (TA) Series

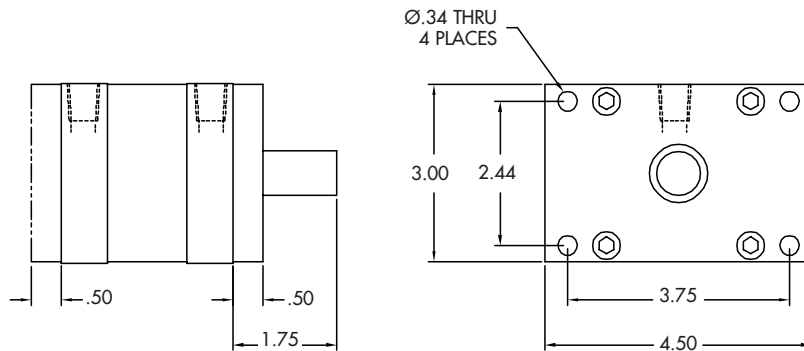

NOTE: Side Mounts surface 3 & 7 are standard, but are not shown for clarity. Standard Bottom Mount dimensions shown on page 8.

BRUTE (BR) Series*

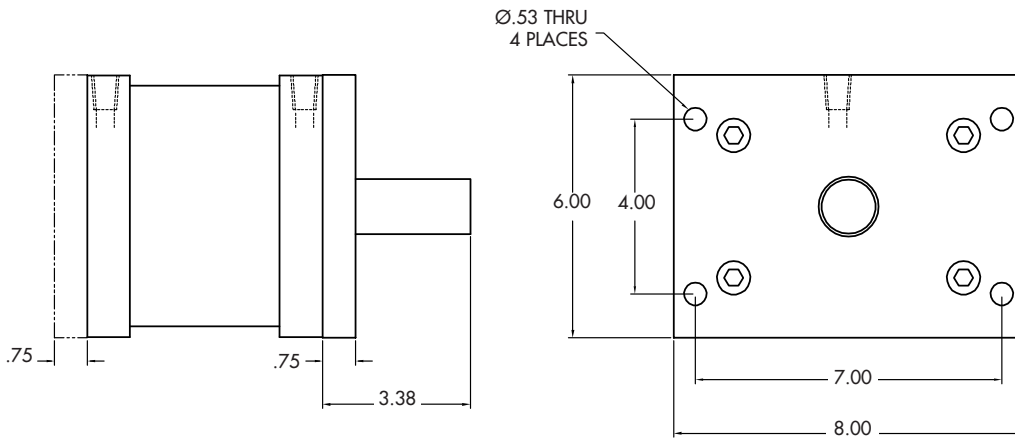

NOTE: The Flange Mount option and Adjustable Stroke Control option may not be ordered on the same end of a unit.

NOTE: Side Mounts surface 3 & 7 are standard, but are not shown for clarity. Standard Bottom Mount dimensions shown on page 12.

| Option# | Description |
|---|-----------------------|
| 100 | Front Flange |
| 101 | Rear Flange |
| 102 | Front and Rear Flange |
| Front Flange and Front ASC Combined (See page 15) | |

*NOTE: When ordering Brute with Flange Mount the bearing retaining plate is eliminated. The flange itself serves as the retainer.

Options – Combination Flange

The flange option can be combined with either head, or the Adjustable Stroke Control housing of the actuator to minimize the overall length of the actuator.

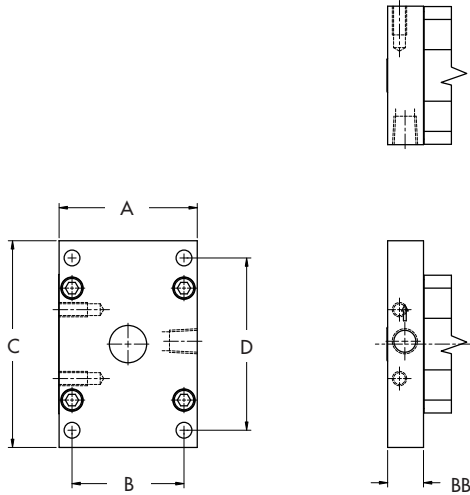

Combination Flange/Rod Head: Port shown on long side.



TURN-ACT ACTUATOR WITH INTEGRAL RODHEAD FLANGE OPTION, PORT ON SHORT SIDE.

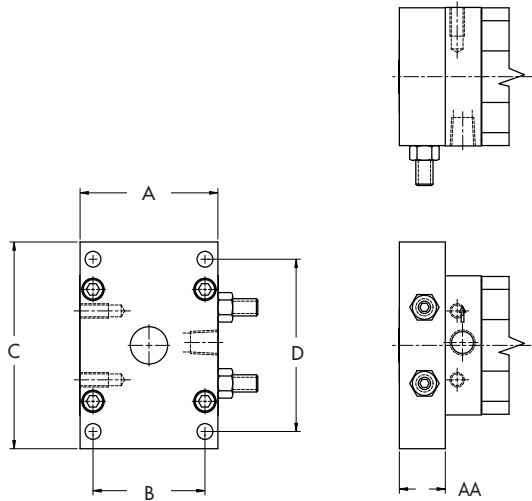

Combination Flange/Adjustable Stroke Control (ASC) Housing:
The ASC housing and the flange are machined from a single piece of aluminum.

| Combo Flanges | Comp-Act (CA) Series | Turn-Act (TA) Series | Brute (BR) Series |
|------------------|----------------------|----------------------|-------------------|
| A | 1.65 | 3.00 | 6.00 |
| B | 1.25 | 2.44 | 4.00 |
| C | 3.00 | 4.50 | 8.00 |
| D | 2.38 | 3.75 | 7.00 |
| EE | 0.28 | 0.34 | 0.53 |
| ASC Flange (AA) | 0.656 | 1.000 | 1.50 |
| Flange Head (BB) | 0.656 | 0.781 | 0.975 |

| Option # | Description |
|----------|---|
| 105 | Flange Mount integral with the Adjustable Stroke Control Housing Front Mount. |
| 108 | Flange Mount integral with the Adjustable Stroke Control Housing Rear Mount. |
| 110 | Flange Mount integral with the Rod Head. Flange positioned with the port on the Short side. |
| 111 | Flange Mount integral with the Cap Head. Flange positioned with the port on the Short side. |
| 120 | Flange Mount integral with the Rod Head. Flange positioned with the port on the Long side. |
| 121 | Flange Mount integral with the Cap Head. Flange positioned with the port on the Long side. |

Options – Side Angle Mounts

| Option # | Description |
|----------|---|
| 200 | Side Angle Brackets, Mounting Surface 3 & 7 |
| 201 | Side Angle Brackets, Mounting Surface 2 & 6 |
| 202 | Side Angle Brackets, Mounting Surface 4 & 8 |
| 203 | Side Angle Brackets, Mounting Surface 1 & 5 |

NOTE: Specify the surface to be used for mounting. Example: Option 200 would call out surface 3 & 7 as the mounting surface, Option #201 would call out surface 2 & 6 as the mounting surface.

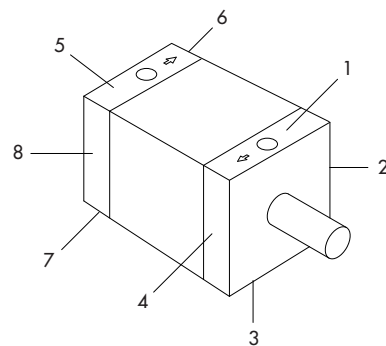

Mounting Surface Reference Drawing

TURN-ACT (TA) Series

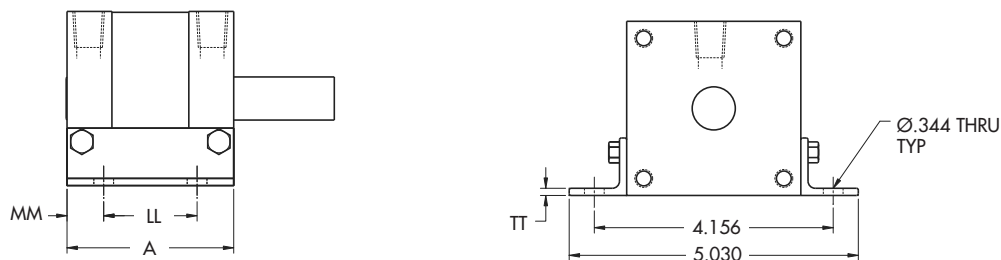

Option 200
Shown in Drawing

| Turn-Act Model | A | LL | MM | TT |
|----------------|-------|-------|------|------|
| 11X | 2.90 | 1.625 | .638 | .125 |
| 12X | 4.39 | 3.000 | .694 | .125 |
| 13X | 7.42 | 6.000 | .712 | .125 |
| 14X | 10.38 | 9.125 | .626 | .188 |

BRUTE (BR) Series

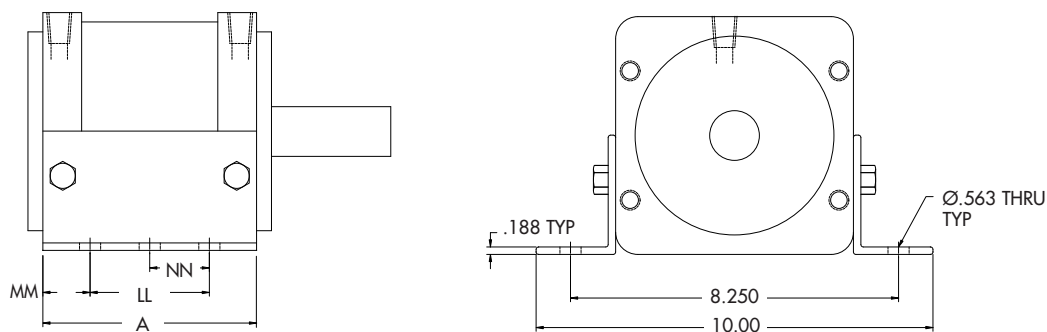

Option 200
Shown in Drawing

| Brute Model | A | LL | MM | NN |
|-------------|-------|--------|-------|-------|
| 22X | 3.63 | 1.625 | 1.000 | N/A |
| 23X | 5.38 | 3.375 | 1.000 | N/A |
| 24X | 7.88 | 4.875 | 1.500 | N/A |
| 25X | 10.88 | 7.875 | 1.500 | 3.938 |
| 26X | 13.88 | 10.875 | 1.500 | 5.438 |

Options – Conveyor Mounting

Simple Conveyor Stop, Diverter, Transfer and Sorting Solutions

Overview

Now adding a Diverter Arm or Conveyor Stop to your conveyor is simple. Compact Automation now offers a low profile, fully adjustable mounting bracket for easy attachment of our Comp-Act or Turn-Act Series Actuators to either side of a conveyor. This new #250 Option provides a bracket for attaching the actuator to the conveyor.

Diverter Arm



Conveyor Stop

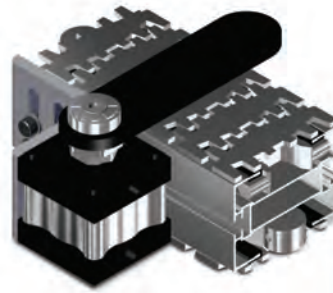

(Shown with optional Trantorque coupling)

Standard Catalog Options:

- Position Sensors/Switches
- Adjustable Stroke Control (ASC)
- Bumpers
- Side Mounting Options
- Port Locations
- Shaft Couplings & Hubs
- Diverter/Stop arms available - Consult Factory

Non-Catalog Standard Options:

- Shaft Modifications
- Multiple Surface Coatings
- Washdown Options
- 100's of Additional Options Available
- Clean Room Options



Comp-Act Series

90° rotation, 1-5/8" sq. body

- Model 022 = 25 in-lbs.
- Model 032 = 44 in-lbs.
- Model 042 = 60 in-lbs.



Turn-Act Series

45° / 90° rotation, 3" sq. body

- Model 112 = 175 in-lbs.
- Model 122 = 350 in-lbs.
- Model 132 = 700 in-lbs.

This option is also available in the lower cost OEM Series.

For more information please contact your local Compact Automation distributor or representative today!

Options – Conveyor Mounting

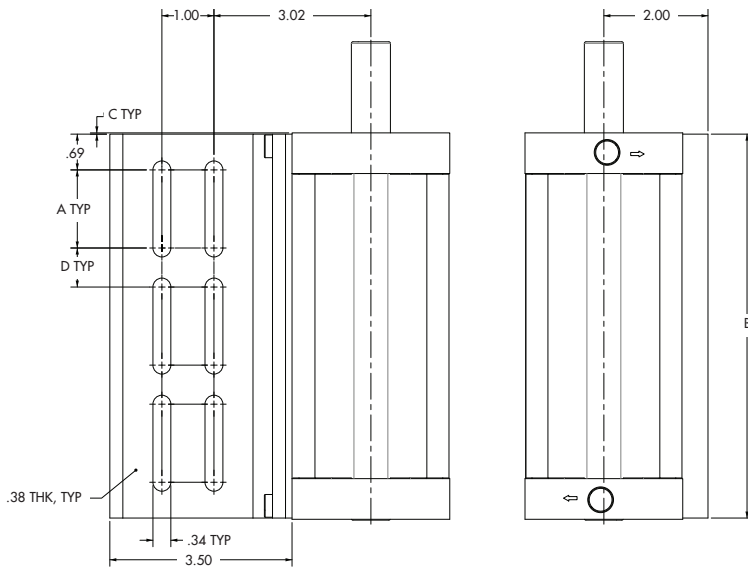

Option 250 TURN-ACT (TA) Side Mount

| Model | A | B | C | D |
|----------------|------|------|-----|-----|
| 112 (2X Slots) | 1.50 | 2.88 | .01 | N/A |
| 122 (4X Slots) | 1.25 | 4.38 | .01 | .50 |
| 132 (6X Slots) | 1.50 | 7.38 | .02 | .75 |

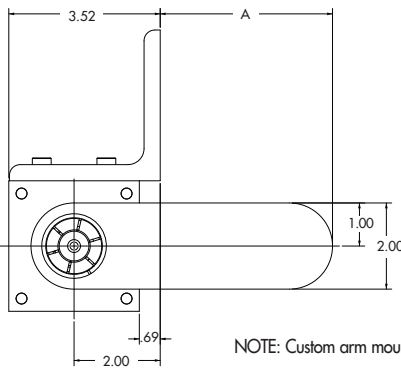

Option 250 TURN-ACT (TA) Arm Mount

| Model | A |
|-------|-------|
| 251 | 2.00 |
| 252 | 4.00 |
| 253 | 6.00 |
| 254 | 8.00 |
| 255 | 10.00 |
| 256 | 12.00 |

NOTE: Custom arm mount lengths available, please consult factory for options.

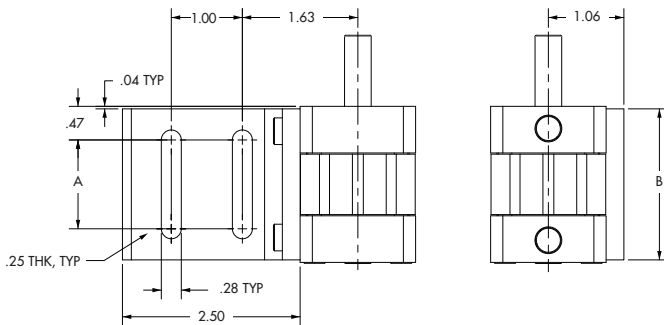

Option 250 COMP-ACT (CA) Side Mount

| Model | A | B |
|-------|------|------|
| 022 | 1.25 | 2.13 |
| 032 | 1.75 | 2.63 |
| 042 | 2.25 | 3.13 |

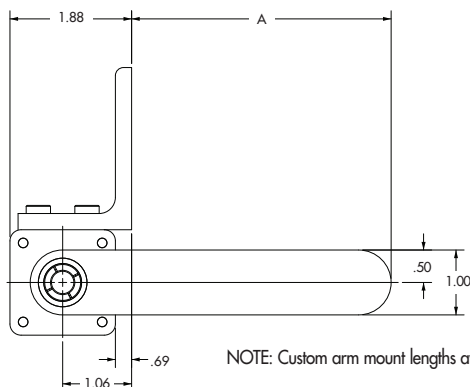

Option 250 COMP-ACT (CA) Arm Mount

| Model | A |
|-------|------|
| 251 | 2.00 |
| 252 | 4.00 |

NOTE: Custom arm mount lengths available, please consult factory for options.

Options – Extended Tie Rods

| Option # | Description |
|------------------|-----------------------------------|
| 300 | Extended Tie Rods, Front |
| 301 | Extended Tie Rods, Rear |
| 302 ¹ | Extended Tie Rods, Front and Rear |

NOTE: Tie rod material (Carbon Steel or Stainless Steel) is determined by the Unit Material selected for the base actuator. The Extended Tie Rod option eliminates the standard front mounts.

1. Option 302 is not available on the Comp-Act Series actuators. Consult Factory for other variations of this option.

COMP-ACT (CA) Series

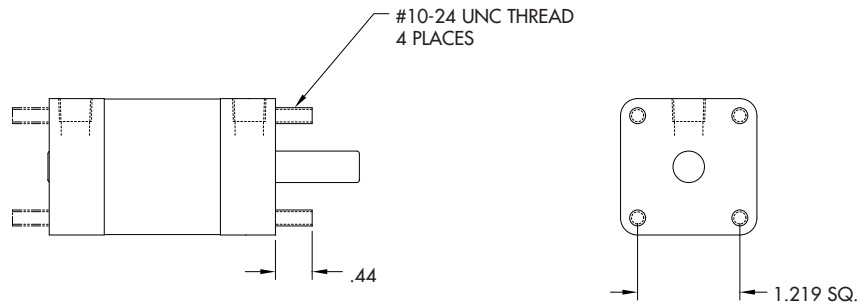

TURN-ACT (TA) Series

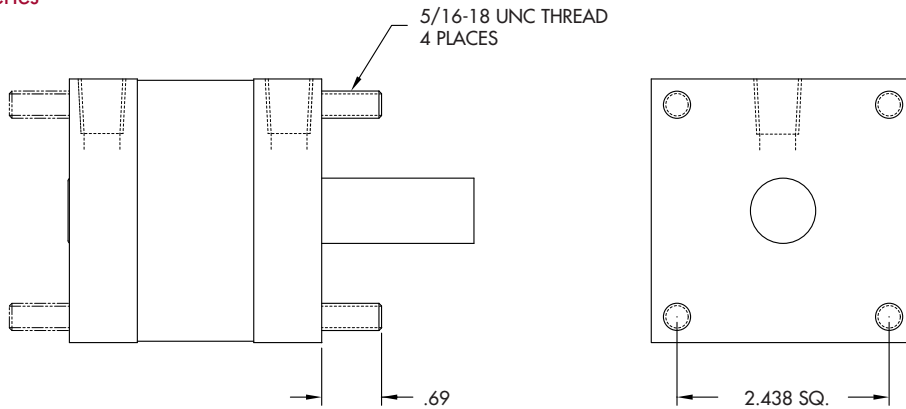

BRUTE (BR) Series

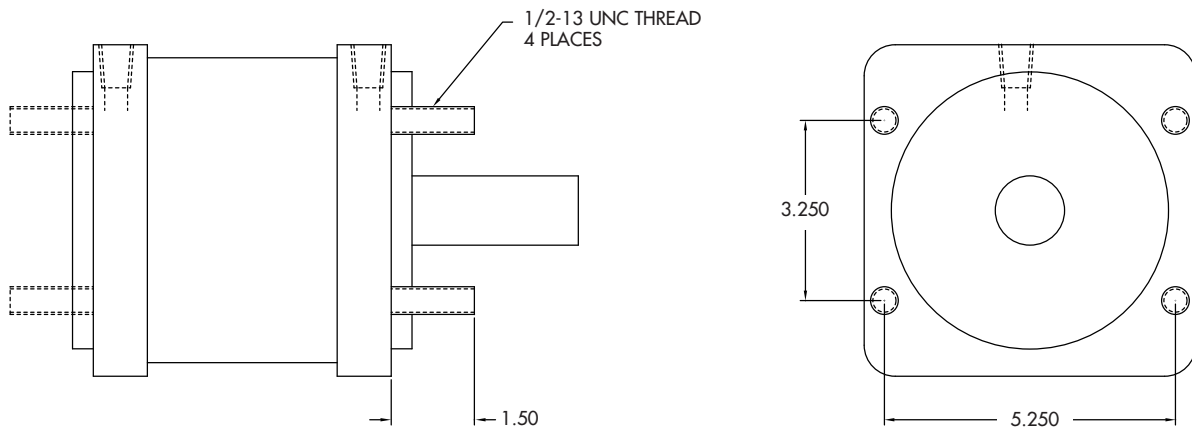

Options – Side Mounts

| Option # | Description |
|--|--------------------------------|
| SIDE MOUNTS, SIDES 3 & 7 STANDARD ON ALL MODELS | |
| 800 | Side Mounts, Sides 1 & 5 |
| 801 | Side Mounts, Sides 2 & 6 |
| 803 | Side Mounts, Sides 4 & 8 |
| 804 | Side Mounts, Sides 2, 4, 6 & 8 |
| 806 | Side Mounts, Sides 6 & 8 |
| 807 | Side Mounts, Sides 2 & 4 |
| 810 | No Side Mounts |

NOTE: Specify the side to be used for mounting. Example: Option 804 would call out sides 2, 4, 6 & 8 as the mounting surfaces, as depicted in the drawings below. Mount sides 3 & 7 are standard on all models (CA, TA, BR) but are not shown for clarity.

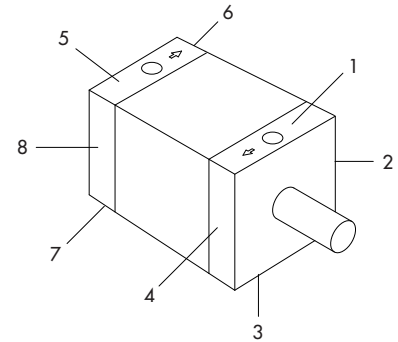

Position Reference Drawing

COMP-ACT (CA) Series

| Comp-Act Models | D |
|-----------------|------|
| 01X | 1.00 |
| 02X | 1.50 |
| 03X | 2.00 |
| 04X | 2.50 |
| 06X | 4.05 |

NOTE: Mounts surface 3 & 7 are standard, but are not shown for clarity. Standard Bottom Mount dimensions shown on page 4.

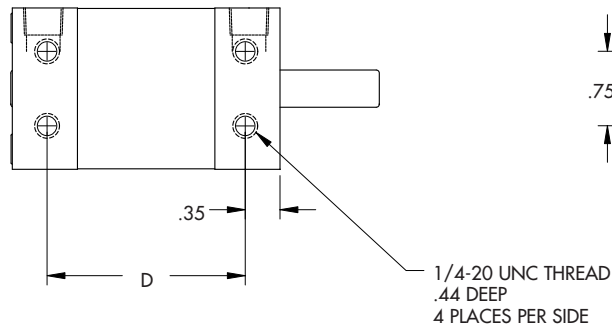

Option 804

TURN-ACT (TA) Series

| Turn-Act Models | D |
|-----------------|------|
| 11X | 2.38 |
| 12X | 3.87 |
| 13X | 6.91 |
| 14X | 9.86 |

NOTE: Mounts surface 3 & 7 are standard, but are not shown for clarity. Standard Bottom Mount dimensions shown on page 8.

NOTE: Center drill omitted from shaft details for clarity.

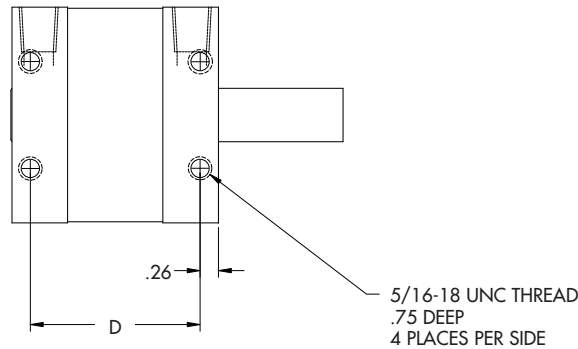

Option 804

BRUTE (BR) Series

| Brute Models | D |
|--------------|-------|
| 22X | 2.63 |
| 23X | 4.38 |
| 24X | 6.88 |
| 25X | 9.88 |
| 26X | 12.88 |

NOTE: Mounts surface 3 & 7 are standard, but are not shown for clarity. Standard Bottom Mount dimensions shown on page 12.

NOTE: Center drill omitted from shaft details for clarity.

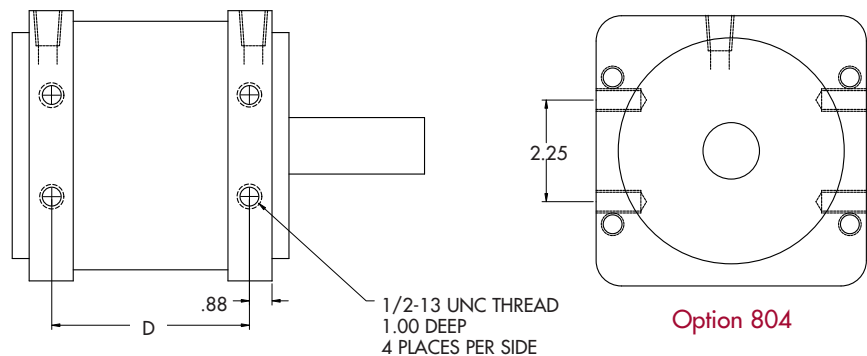

Option 804

Options – Dowel Pin Locators

| Option # | Description |
|----------|--------------------------------|
| 805 | Dowel Pin Locator, Sides 3 & 7 |
| 811 | Dowel Pin Locator, Sides 2 & 6 |
| 812 | Dowel Pin Locator, Sides 4 & 8 |

COMP-ACT (CA) Series

| Comp-Act Models | PP |
|-----------------|-------|
| 01X | 0.996 |
| 02X | 1.496 |
| 03X | 1.996 |
| 04X | 2.496 |
| 06X | 4.048 |

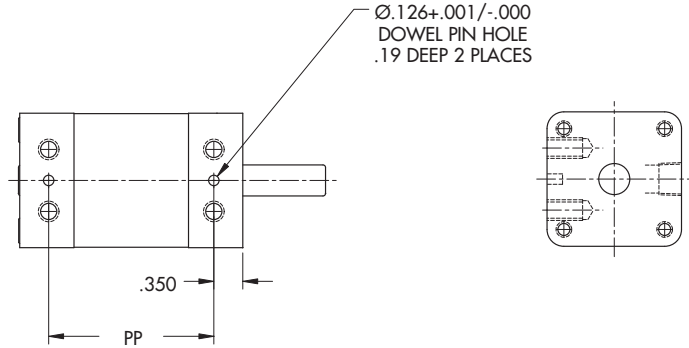

TURN-ACT (TA) Series

| Turn-Act Models | PP |
|-----------------|-------|
| 11X | 2.384 |
| 12X | 3.877 |
| 13X | 6.907 |
| 14X | 9.860 |

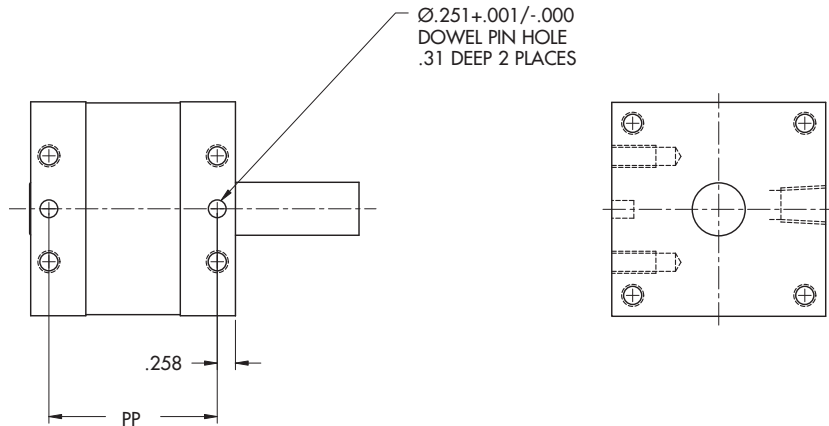

NOTE: Center drill omitted from shaft details for clarity.

BRUTE (BR) Series

| Brute Models | PP |
|--------------|--------|
| 22X | 2.624 |
| 23X | 4.374 |
| 24X | 6.874 |
| 25X | 9.894 |
| 26X | 12.894 |

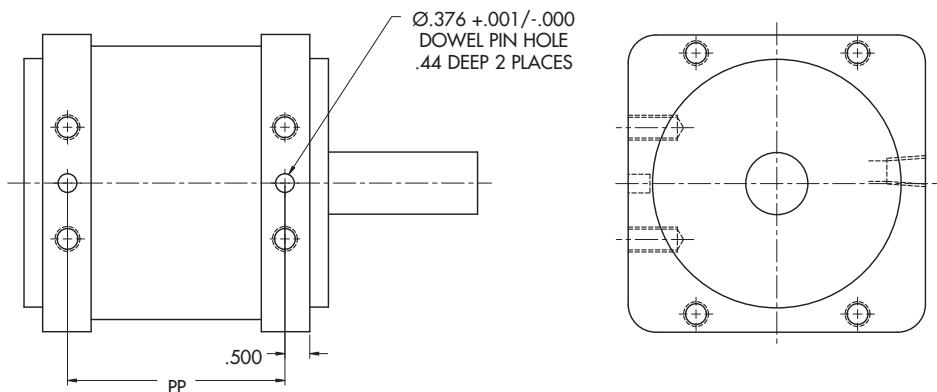

NOTE: Center drill omitted from shaft details for clarity.

Options – Three Hole Face Mount

| Option # | Description |
|----------|-----------------------|
| 830 | Three Hole Face Mount |

NOTE: Not available in Brute series

TAP #10-32 UNF .38 DP
3 PLCS EQUALLY
SPACED ON Ø1.28 B.C.

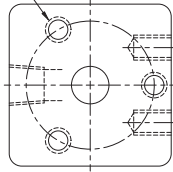

COMP-ACT (CA) Series

TAP 5/16-18 UNC .50 DP
3 PLCS EQUALLY
SPACED ON Ø2.44 B.C.

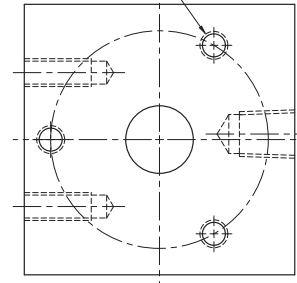

TURN-ACT (TA) Series

Options – Low Profile Actuators

This option provides shorter overall length when available space will not permit the use of standard product. The standard End Caps and Needle Bearings are replaced with "Thinner" End Caps and PTFE Bearing Surfaces. This option requires smaller than standard air inlets. The Low Profile option reduces the side load rating of the actuator to 50lbs. in the Comp-Act Series and 100lbs. in the Turn-Act Series. This option is not available on the Brute Series.



COMP-ACT SERIES ACTUATOR WITH LOW PROFILE HEADS AND TEFLON IMPREGNATED ANODIZING (OPTION 704) WITH SHAFT TURNED DOWN

| How to Order | Description |
|--|-----------------------|
| Under the "End Cap" Selection section of the "How to Order" Comp-Act or Turn-Act Series Models – Select #2 | Low Profile Actuators |

NOTE:

1. Low Profile Heads reduce the side load rating of the actuator. Not available in Brute series.

COMP-ACT (CA) Series

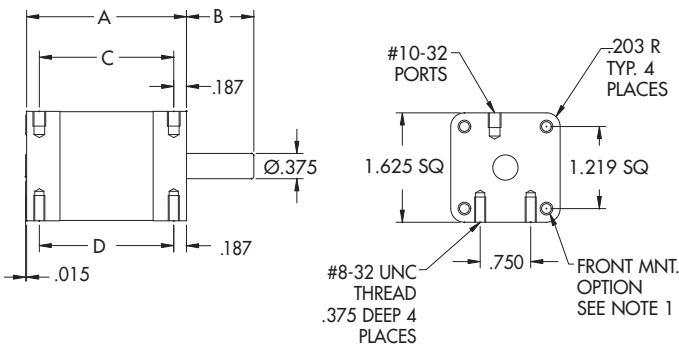

TURN-ACT (TA) Series

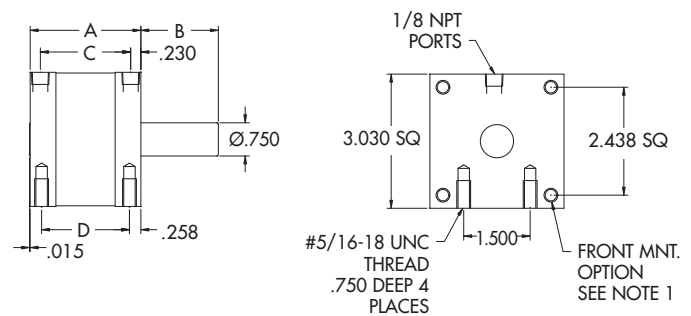

NOTE:

1. Only available with Extended Tie Rods or Combination Flange options. Consult Factory.

| Comp-Act Models | A | B | C | D |
|-----------------|-------|-------|-------|-------|
| 01X | 1.375 | 1.000 | 1.000 | 1.000 |
| 02X | 1.875 | 1.000 | 1.500 | 1.500 |
| 03X | 2.375 | 1.000 | 2.000 | 2.000 |
| 04X | 2.875 | 1.000 | 2.500 | 2.500 |
| 06X | 4.425 | 1.000 | 4.050 | 4.050 |

| Turn-Act Models | A | B | C | D |
|-----------------|-------|-------|-------|-------|
| 11X | 2.500 | 1.750 | 2.040 | 1.984 |
| 12X | 4.000 | 1.750 | 3.540 | 3.484 |
| 13X | 7.020 | 1.750 | 6.560 | 6.504 |
| 14X | 9.980 | 1.750 | 9.520 | 9.464 |

Options – Adjustable Stroke Control (ASC)

The Adjustable Stroke Control (ASC) option allows an actuator to be adjusted to the exact rotational stroke desired. The “ASC” option consists of a shaft mounted steel cam, enclosed in a housing with control screws (see method of operation below). Turning the control screws either extends or limits the amount of rotation. The ends of the control screws impact the cam providing a positive and repeatable end of rotation stop. The ASC option is often specified for applications where the stroke required is not within the rotational tolerance. The standard rotational stroke tolerance of an actuator is $+4^{\circ}/-0^{\circ}$. (i.e.: A 90-degree actuator without ASC will have a rotation of $90^{\circ}-94^{\circ}$ with the addition of the ASC option a precise 90° rotation is attainable.)

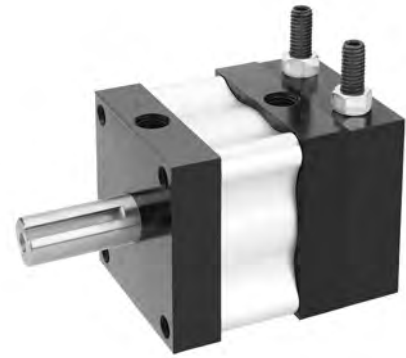

| Option # | Description |
|----------|--------------------------|
| 400 | ASC Cap End, Position 5 |
| 401 | ASC Rod End, Position 1 |
| 402 | ASC Cap End, Position 6* |
| 403 | ASC Rod End, Position 2* |
| 404 | ASC Cap End, Position 7 |
| 405 | ASC Rod End, Position 3 |
| 406 | ASC Cap End, Position 8* |
| 407 | ASC Rod End, Position 4* |

* Bottom mnt. pattern changes to side mnt. dimensions (see pg. 18) on ASC end only - Brute Series

NOTE:

- Contact Factory for other adjusting ranges.
- The Thrust Protection Option (see pg. 22) can be integrated into the ASC Housing to minimize the overall length of the actuator.

| Actuator Rotation | Adjusting Range |
|-------------------|-----------------|
| *45° | 0-45 degrees |
| 90° | 0-90 degrees |
| **110° | 0-110 degrees |
| 180° | 90-180 degrees |
| 270° | 90-270 degrees |
| **290° | 90-290 degrees |

* Turn-Act Series Only

** Brute Series Only

NOTE: Rotations greater than 180° are not fully adjustable with a standard 2 screw adjustable stroke control. Consult factory for greater adjustment range.

| Adjustable Stroke Control (ASC) Dimension | | | | |
|---|--------------|---------|-------------|---------|
| MODEL/Series | (A =max) in. | (B) in. | (C) in. Sq. | (D) in. |
| Comp-Act (CA) | 1.500 | 0.656 | 1.63 | .130 |
| Turn-Act (TA) | 3.250 | 1.000 | 3.00 | .200 |
| Brute (BR) | 6.500 | 1.500 | 5.98 | N/A |

POSITION REFERENCE DRAWING

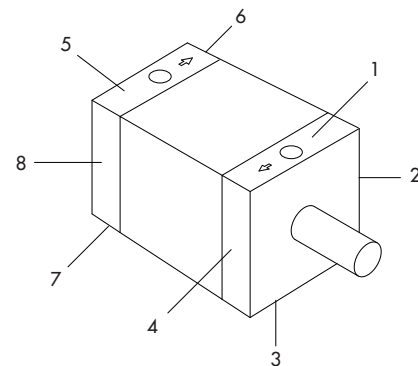

NOTE: Specify the position to be tapped for adjustment screws. Example: Option 407 would call out position 4 as the adjustment screw location, as depicted in the drawing above.

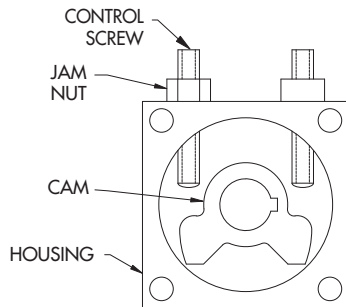

METHOD OF OPERATION

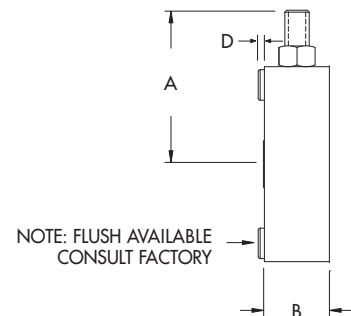
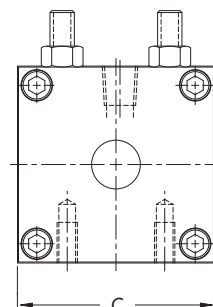

NOTE: FLUSH AVAILABLE
CONSULT FACTORY

DIMENSIONAL DATA

Options – Thrust Protection

Standard Turn-Act Rotary actuators are designed to accommodate high side (radial) loads and relatively light end (thrust) loads. Excessive thrust load will cause premature seal wear and shorten actuator cycle life. (See chart below.) Applications that produce high linear/thrust loads, such as when the shaft is vertical, with the load set on or hanging from the shaft may require the Thrust Protection option.

This option consists of a series of internal thrust bearings and a shaft collar enclosed in a machined aluminum housing. This system effectively isolates the load from the actuator vane, permitting higher thrust load limits. (See chart.)

NOTE: The Adjustable Stroke Control (ASC) Option can be integrated into the Thrust Protection Housing to minimize the overall length of the actuator (See pg 21).



TURN-ACT SERIES ACTUATOR WITH OPTIONAL THRUST PROTECTION AND TEFLON IMPREGNATED ANODIZING

| Option # | Position |
|----------|----------|
| 900 | Cap End |
| 901 | Rod End |

| Series | Load Limit Without Thrust Protection | Load Limit With Thrust Protection | (A) IN. SQ. | (B) IN. |
|---------------|--------------------------------------|-----------------------------------|-------------|---------|
| Comp-Act (CA) | 10 LBS | 250 LBS | 1.62 | .656 |
| Turn-Act (TA) | 25 LBS | 500 L | 3.03 | 1.000 |
| Brute (BR) | 1000 LBS | CONSULT FACTORY | | |

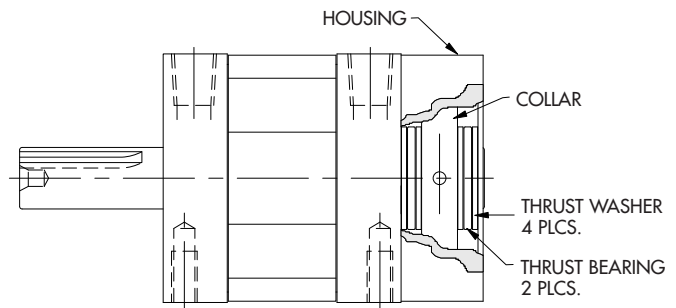
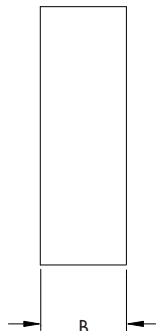
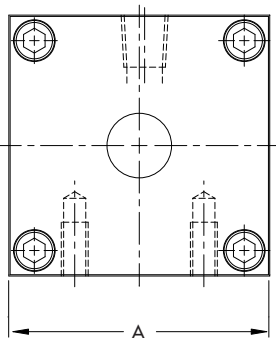

Options – Internal Rotation Stop

Turn-Act rotary actuators are available with nominal 45, 90, 110, 180, 270 and 290 degree rotations. Adjustable stroke control frequently fills the requirement for other than nominal rotations. Some applications have the additional requirement of preventing any user adjustability.

To fill these requirements of:

- A specific non-standard rotation
- User non-adjustability

The Internal Rotation Stop option is accomplished through the use of an extrusion that is bonded to the inner diameter of the rotary actuator tube. This extrusion is machined to restrict the rotation of the actuator. This option can be used to enhance the response time of an actuator by consuming the excess volume of the rotary actuator.

NOTE: A rotation tolerance of +4/-0 degrees is standard, closer tolerance is available. Consult Factory.



INTERNAL STOP

Options – Urethane Bumpers

Polyurethane BUMPERS absorb kinetic energy and reduces noise at the end of stroke. Actual rotation and repeatability achieved when bumpers are installed will be dependent on Load... Air Pressure... and Speed of Rotation.

| Series | Option # |
|---------------|----------|
| Comp-Act (CA) | B00 |
| Turn-Act (TA) | B00 |
| Brute (BR)* | B00 |

NOTE: Only 1 end of rotation can be bumpered when the 45-degree rotor is ordered.

* 180° Brute Units (B99)

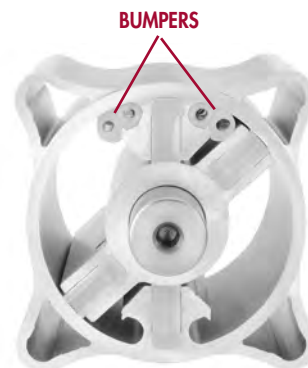

BUMPERS

Options – Motion Control Package

Flow controls are frequently used to affect the speed of rotary and linear actuators. However, in some applications, such as over-center rotary loads, flow controls do not adequately check the speed of rotation. In these types of applications the TURN-ACT Motion Control option can provide effective speed control.

The TURN-ACT Motion Control package is available on the Comp-Act, Turn-Act and Brute Series of rotary vane actuators.

The system consists of 2 linked yet independent rotary actuators, which share a common shaft. (See photo.) The "Rod End" actuator moves the load. The "Control" actuator is oil filled and controls the speed of actuation. A needle valve meters the flow of the fluid through the control actuator. This option provides a uniform, controlled speed of the actuator throughout its rotation.

This integral Motion Control Package provides a smooth controlled actuation while eliminating the need for external Air/Oil systems.

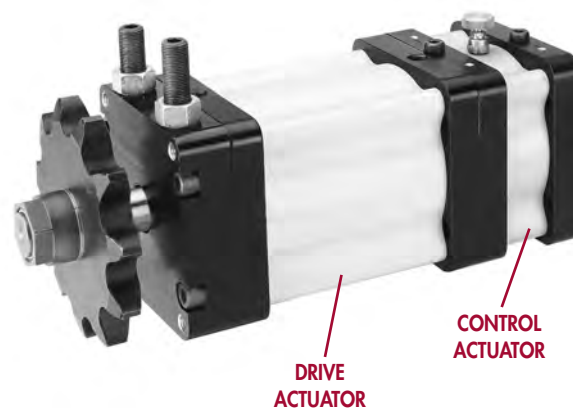

BRUTE SERIES ACTUATOR WITH OPTIONAL ADJUSTABLE STROKE CONTROL AND MOTION CONTROL.

Consult factory for application information.

Options – Cap Switch Systems

Turn-Act Rotary Vane Actuators are available with electronic position sensing switches. The switches have LED lamps that light when in sensing position. If adjusted for end of stroke indication, the LED will remain lit as long as the stroke position is maintained. A small shaft mounted magnet in the switch housing operates the switches (See drawings).



SWITCH SYSTEM WITH 8MM QUICK DISCONNECT



SWITCH SYSTEM WITH 9 FT. LEADS

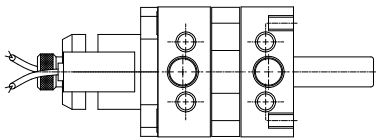
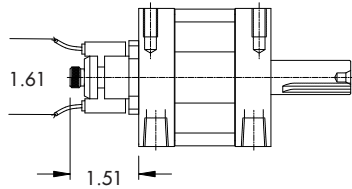

COMP-ACT (CA) SERIES SWITCHES

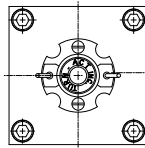

TURN-ACT (TA) SERIES SWITCHES

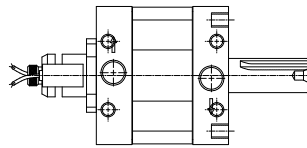

BRUTE (BR) SERIES SWITCHES

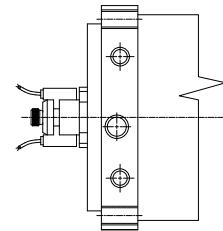

| SWITCH PACKAGE (CAP END) | | | | | | | |
|---|-----------------------------|-------------------------|--------------------|---------------------------|-------------------------------|-----------------|-------------------|
| Includes a Cap End Mounted Switch Ready Housing | | | | | | | |
| Option #* | Switch Type | Function | Lead Type | Switching Voltage | Switching Current | Switching Power | Max. Voltage Drop |
| A00 | Switch Ready No Switches | | | | | | |
| A05 | PNP/Sourcing | Normally Open Output | 22 gauge | 6-24 VDC | 0.5 Amp Max | N/A | 0.5 Volts |
| A08 | NPN/Sinking | Normally Open Output | 22 gauge | 6-24 VDC | 0.5 Amp Max | N/A | 0.5 Volts |
| A02 | AC/DC Reed | SPST Normally Open | 22 gauge | 5-120 VDC/VAC 50/60 Hz | 0.5 Amp Max 0.005 Amp min. | 10 watts Max | 3.5 Volts |
| A25 | PNP/Sourcing | Normally Open Output | 8mm Type - B QD | 6-24VDC | 0.5 Amp Max | N/A | 0.5 Volts |
| A28 | NPN/Sinking | Normally Open Output | 8mm Type - B QD | 6-24VDC | 0.5 Amp Max | N/A | 0.5 Volts |
| A22 | AC/DC Reed | SPST Normally Open | 8mm Type - B QD | 5-120 VDC/VAC 50/60 Hz | 0.5 Amp Max 0.005 Amp min. | 10 watts Max | 3.5 Volts |

*Caution: Switches will be permanently damaged if operated without a load. Consult factory if lead length will exceed 20 feet.

Options – Disk Switch Systems

Turn-Act Rotary Vane Actuators are available with the DISK Switch System. It is designed for use with double end actuators or when the available space will not permit the use of other switch options. The Disk Switch System includes a shaft extension to accommodate a shaft-mounted magnet disk. The switches are mounted in dovetail grooves located to sense the disk-mounted magnet (Actuator shown with thrust protection option).

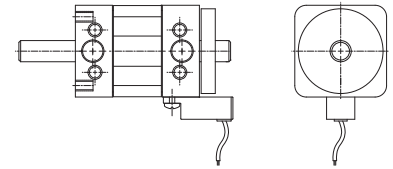

COMP-ACT (CA) DISK SWITCHES



COMP-ACT DISK SWITCH

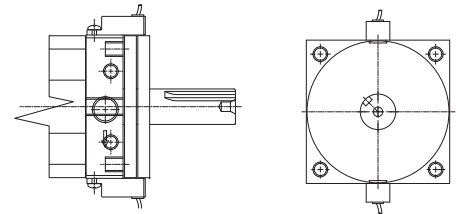

TURN-ACT (TA) DISK SWITCH

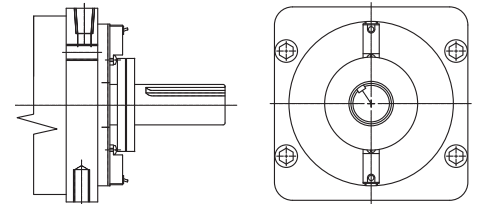

BRUTE (BR) DISK SWITCH

Typical Disk Switch configurations: Consult factory for precise dimensions.

| DISK SWITCH (CAP END) | | | | | | | |
|---|-----------------------------|-------------------------|--------------------|---------------------------|-------------------------------|-----------------|-------------------|
| Includes 2 Each <u>Rear Mounted Magnet Disks and Dove-Tail Grooves on the Cap Ends to Accept Switches</u> | | | | | | | |
| Option #* | Switch Type | Function | Lead Type | Switching Voltage | Switching Current | Switching Power | Max. Voltage Drop |
| Consult Factory | Switch Ready No Switches | | | | | | |
| Consult Factory | PNP/Sourcing | Normally Open Output | 22 gauge | 6-24 VDC Max | 0.5 Amp | N/A | 0.5 Volts |
| Consult Factory | NPN/Sinking | Normally Open Output | 22 gauge | 6-24 VDC Max | 0.5 Amp | N/A | 0.5 Volts |
| Consult Factory | AC/DC Reed | SPST Normally Open | 22 gauge | 5-120 VDC/VAC 50/60 Hz | 0.5 Amp Max 0.005 Amp min. | 10 watts Max | 3.5 Volts |
| Consult Factory | PNP/Sourcing | Normally Open Output | 8mm Type - B QD | 6-24VDC | 0.5 Amp Max | N/A | 0.5 Volts |
| Consult Factory | NPN/Sinking | Normally Open Output | 8mm Type - B QD | 6-24VDC | 0.5 Amp Max | N/A | 0.5 Volts |
| Consult Factory | AC/DC Reed | SPST Normally Open | 8mm Type - B QD | 5-120 VDC/VAC 50/60 Hz | 0.5 Amp Max 0.005 Amp min. | 10 watts Max | 3.5 Volts |

*See Page 27 for wiring diagrams.

Options – Disk Switch Systems

| DISK SWITCHES (1 SWITCH EACH END) | | | | | | | |
|---|-----------------------------|-----------------------|--------------------|---------------------------|-------------------------------|-----------------|-------------------|
| Includes 1 Each <u>Front</u> and 1 Each <u>Rear</u> Mounted Magnet Disks and Dove-Tail Grooves on the Rod and Cap Ends to Accept Switches | | | | | | | |
| Option #* | Switch Type | Function | Lead Type | Switching Voltage | Switching Current | Switching Power | Max. Voltage Drop |
| Consult Factory | Switch Ready No Switches | | | | | | |
| Consult Factory | PNP/Sourcing | Normally Open Output | 22 gauge | 6-24 VDC Max | 0.5 Amp | N/A | 0.5 Volts |
| Consult Factory | NPN/Sinking | Normally Open Output | 22 gauge | 6-24 VDC Max | 0.5 Amp | N/A | 0.5 Volts |
| Consult Factory | AC/DC Reed | SPST Normally Open | 22 gauge | 5-120 VDC/VAC 50/60 Hz | 0.5 Amp Max 0.005 Amp min. | 10 watts Max | 3.5 Volts |
| Consult Factory | PNP/Sourcing | Normally Open Output | 8mm Type - B QD | 6-24VDC | 0.5 Amp Max | N/A | 0.5 Volts |
| Consult Factory | NPN/Sinking | Normally Open Output | 8mm Type - B QD | 6-24VDC | 0.5 Amp Max | N/A | 0.5 Volts |
| Consult Factory | AC/DC Reed | SPST Normally Open | 8mm Type - B QD | 5-120 VDC/VAC 50/60 Hz | 0.5 Amp Max 0.005 Amp min. | 10 watts Max | 3.5 Volts |

*See Page 27 for wiring diagrams.

| DISK SWITCH (ROD END) | | | | | | | |
|---|-----------------------------|-----------------------|--------------------|---------------------------|-------------------------------|-----------------|-------------------|
| Includes 2 Each <u>Rod End</u> Mounted Magnet Disks and Dove-Tail Grooves on the Rod End to Accept Switches | | | | | | | |
| Option #* | Switch Type | Function | Lead Type | Switching Voltage | Switching Current | Switching Power | Max. Voltage Drop |
| Consult Factory | Switch Ready No Switches | | | | | | |
| Consult Factory | PNP/Sourcing | Normally Open Output | 22 gauge | 6-24 VDC Max | 0.5 Amp | N/A | 0.5 Volts |
| Consult Factory | NPN/Sinking | Normally Open Output | 22 gauge | 6-24 VDC Max | 0.5 Amp | N/A | 0.5 Volts |
| Consult Factory | AC/DC Reed | SPST Normally Open | 22 gauge | 5-120 VDC.VAC 50/60 Hz | 0.5 Amp Max 0.005 Amp min. | 10 watts Max | 3.5 Volts |
| Consult Factory | PNP/Sourcing | Normally Open Output | 8mm Type - B QD | 6-24VDC | 0.5 Amp Max | N/A | 0.5 Volts |
| Consult Factory | NPN/Sinking | Normally Open Output | 8mm Type - B QD | 6-24VDC | 0.5 Amp Max | N/A | 0.5 Volts |
| Consult Factory | AC/DC Reed | SPST Normally Open | 8mm Type - B QD | 5-120 VDC.VAC 50/60 Hz | 0.5 Amp Max 0.005 Amp min. | 10 watts Max | 3.5 Volts |

*See Page 27 for wiring diagrams.

Options – Switches: Wiring Diagrams

WIRE LEADS

NPN/PNP Switch with LED

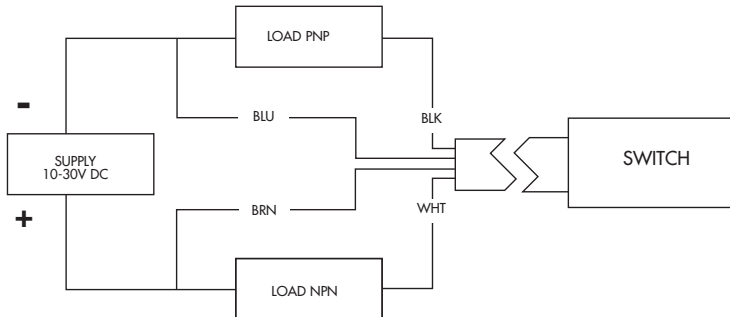

AC/DC Reed Switch MOV* with LED

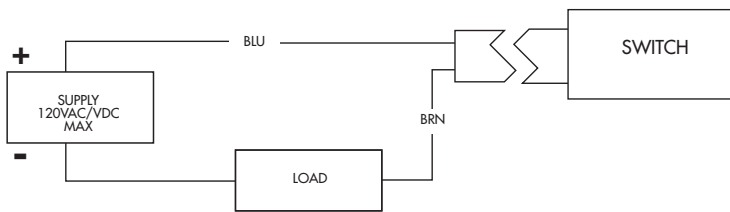

*NOTE: Power supply polarity need not be observed in AC applications.

QUICK DISCONNECT TYPE – B

PNP Sourcing Switch with LED and Type - B Quick Disconnect

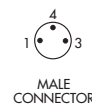
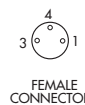
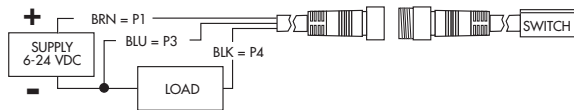

NPN Sinking Switch with LED and Type - B Quick Disconnect

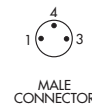
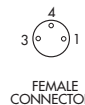
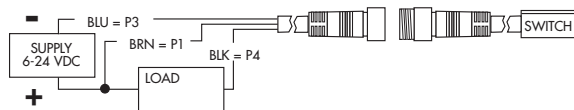

AC/DC Reed Switch MOV* with LED and Type - B Quick Disconnect

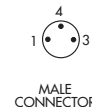
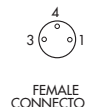
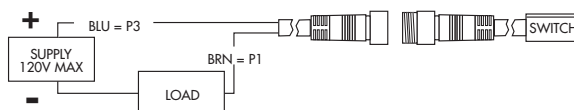

*NOTE: Power supply polarity need not be observed in AC applications.
Metal oxide varistor surge suppression.

LEAD LENGTHS

Wire Leads – 9"
Quick Disconnect:
Pigtail – 6"
Cordset – 15"

CAUTION: TO AVOID PERMANENT DAMAGE TO SWITCHES

- 1 Do not exceed rated voltage
- 2 Observe power supply polarity
- 3 Do not operate without a load
- 4 Do not short circuit the load
- 5 Consult factory if lead length will exceed 20 ft.

ROTATIONAL LIMITS

Any rotational limits (including Adjustable Stroke Control settings) must be made prior to adjusting switches. Changes in rotation will require the switches to be re-adjusted.

ALLEN-BRADLEY PLC'S

With I/O module #1791 require reed switches with internal current limiting protection. This feature is now standard.

Options – Electrical Position Indication (EPI)

The EPI switch system consists of a steel cam that rotates with the actuator vane. This assembly is enclosed in a housing. The housing is tapped to accept a threaded body switch (GO® Switches). When threaded into the EPI housing, the switch senses the cam as it approaches the end of stroke.



TURN-ACT FULL STAINLESS STEEL BODY ACTUATOR AND OPTION 500

| How to Order Electrical Position Indication (EPI) | |
|---|---|
| (EPI) Option # | Description: Includes housing, ferrous cam with or without switches as specified below. |
| 500 | EPI Cap End, Position 5 – 2 D279 switches included |
| 501 | EPI Rod End, Position 1 – 2 D279 switches included |
| 520 | EPI Cap End, Position 5 – without switches |
| 521 | EPI Cap End, Position 1 – without switches |

The maximum adjusting range is limited to 15° each end of rotation.

POSITION REFERENCE DRAWING

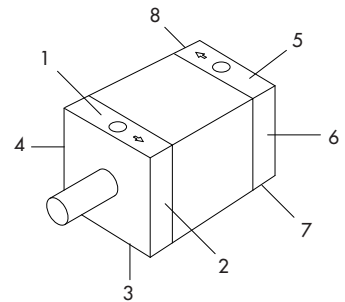

NOTE: Specify the position to be tapped for adjustment screws.
Example: Option 500 would call out position 5 as the prox. switch location, as depicted in the photo above.

| Part # | Switch Type/Manufacturer | Operation | Contacts | Housing |
|--------|--------------------------|-------------------------------|--------------|---|
| D279 | GO/Topworx® | SPDT Magnetic Proximity | 240VAC 2 Amp | 303/304 Stainless Steel Threads 5/8" -18 Environmentally Sealed |
| | | | 24VDC 50ma | |

NOTE: The same system can be adapted for other brands of threaded body switches. The (EPI) Electrical Position Indication is available by option number only on the Turn-Act and Brute Series, for the Comp-Act Series see the Prox Switch Ready option (pg 29).

GO® Switches reg. General Equipment Co.

Consult factory for application information.

Options – Proximity Switch Ready (PSR)

This option is similar to the EPI/Electrical Position Indicator. (See photo pg. 28.) The “Prox Switch Ready” System consists of a shaft mounted ferrous target cam, enclosed in a housing that is tapped to accept your choice of threaded body switch. Comp-Act, Turn-Act, and Brute Actuators are available as “Prox Switch Ready”. (Does Not Include Switches.)



TURN-ACT ACTUATOR WITH PROXIMITY SWITCH READY OPTION

| Option # | | Description |
|----------|---------|-------------------------|
| 530 | 8mm | PSR Cap End, Position 5 |
| 540 | 4mm | PSR Cap End, Position 5 |
| 570** | 12mm | PSR Cap End, Position 5 |
| 571** | 12mm | PSR Rod End, Position 1 |
| 590* | 18mm | PSR Cap End, Position 5 |
| 591* | 18mm | PSR Rod End, Position 1 |
| 420 | 5/16-24 | PSR Cap End, Position 5 |
| 421 | 5/16-24 | PSR Rod End, Position 1 |
| 430** | 3/8-24 | PSR Cap End, Position 5 |
| 431** | 3/8-24 | PSR Rod End, Position 1 |
| 440* | 1/2-20 | PSR Cap End, Position 5 |
| 441* | 1/2-20 | PSR Rod End, Position 1 |

* Brute (BR) series only. Consult factory for Comp-Act and Turn-Act.

** Not available on Comp-Act (CA).

Note: Extreme care needs to be taken when adjusting the switch to insure that the cam does not contact the switch body during actuation. Catastrophic switch failure may occur if the cam contacts the switch body. Do Not Use as an Adjustable Stroke Control. The Adjustable Stroke Control Option (ASC) should be ordered additionally, if the rotation required is outside the standard range and tolerance $+4/-0$ degrees. (See page 21.) Consult Factory for required minimum probe lengths.

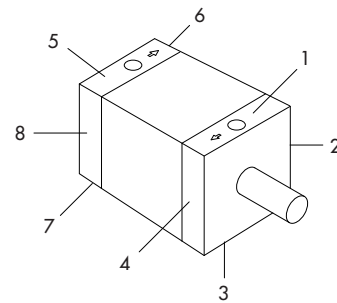

POSITION REFERENCE DRAWING

NOTE: Specify the position to be tapped for prox. switches. Example: Option 530 would call out position 5 as the prox. switch location, as depicted in the drawing above.

Potentiometers and Encoders

Provides continuous Position sensing loop control systems. (See Drawings.)

Customer selected Potentiometers and Encoders can be mounted/adapted to any of Turn-Act's Rotary Vane Actuators for use in closed loop control systems. (See drawings.)

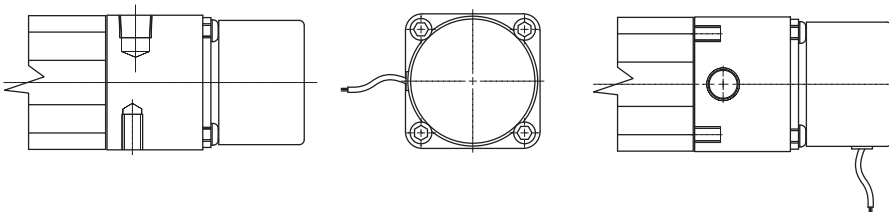

TYPICAL METHOD OF OPERATION ENCLOSED ENCODER MOUNTED TO A TURN-ACT VANE ACTUATOR

Consult factory for application information.



TURN-ACT ACTUATOR WITH ENCODER

Options – Port Locations/Port Types

Below is a partial listing of the inlet/port modifications available.

- Standard port location – Available Port Types and Locations.
- Combination Rod Head and Flange with optional port location
- Double Ports – order to increase actuator response time.
- End Ports – permits access to both ports on the cap head end.

Contact the factory for other options.

STANDARD PORT SIZES

| Comp-Act Series | Turn-Act Series | Brute Series |
|-----------------|-----------------|--------------|
| 1/8 NPT | 1/4 NPT | 3/8 NPT |

AVAILABLE PORT SIZES

| Comp-Act Series | Turn-Act Series | Brute Series |
|-----------------|-----------------|--------------|
| Option# G10 | | |
| 10-32 | 1/8 NPT | 1/4 NPT |



TURN-ACT ACTUATOR AND OPTIONAL END PORTS

Options – Namur Mount

The Namur Mount is a standard connection pattern for mounting a control valve directly to an actuator. This is a working standard for the process control industry. It permits interchangeability between control valve manufacturers.

The pattern consists of:

- 2 drilled orifices to correspond to the valve ports.
- 4 Mounting/Locating holes, which will allow variable valve orientation.

NOTE: Turn-Act does not supply the control valve.



TURN-ACT ACTUATOR WITH (OPTION EN1) NAMUR MOUNTED CONTROL VALVE

| Turn-Act Model | X | Y |
|----------------|-------|-------|
| 11X | 2.38 | 3.34 |
| 12X | 4.04 | 4.99 |
| 13X | 7.07 | 8.02 |
| 14X | 10.02 | 10.98 |

Consult factory based on various manufacturing of namur products.



TURN-ACT ACTUATOR AND OPTIONAL NAMUR MOUNT (OPTION EN1)

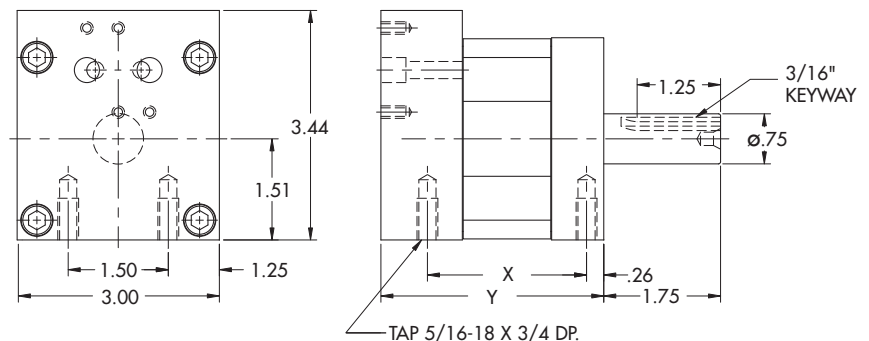

NAMUR REAR MOUNT DRAWING

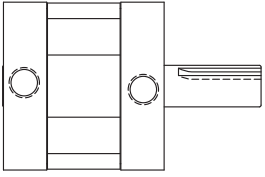

SINGLE KEYWAY

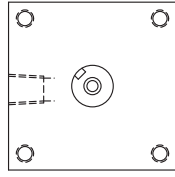

NEED a **MODIFIED**

SHORTER...

LONGER...

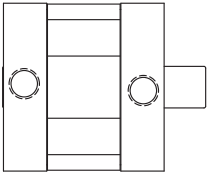

SINGLE END SHORT SHAFT

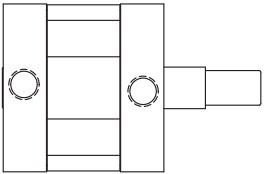

TURNED DOWN

TURNED DOWN...

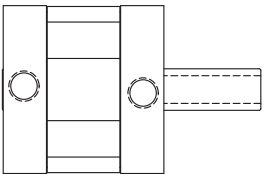

GUN DRILL

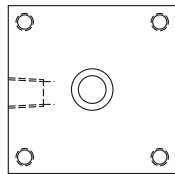

GUN DRILLED...

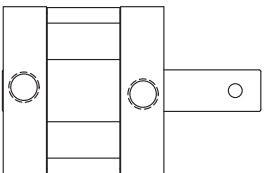

CROSS DRILL HOLE

CROSS DRILLED...

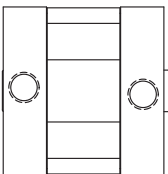

SINGLE END LONG SHAFT

SHAFT...

ANSWER ENGINEERING -

The willingness and ability to modify Turn-Act rotary and linear product to fit a specific application.

RAPID CUSTOM MODIFICATION.

Most of our sales are special orders, so we're prepared to be flexible, responsive and accurate. Modifications can be as simple as a shaft extension or an entirely new product. Most often these modifications go from concept to shipped product faster than the competition ships a standard. Our commitment to Answer Engineering is just a phone call away.

RESPONSIVE to your challenge.

Responsiveness is what Answer Engineering is all about. It's why 60% of our business is custom. You bring us a challenge, and through technical innovation we'll find an answer. Simply put, if you can imagine it, we can make it happen.

CHALLENGE US.

We're confident we can respond to your application needs.

ETC... ETC... ETC...

NOT A PROBLEM. IT'S WHAT WE CALL ANSWER ENGINEERING.

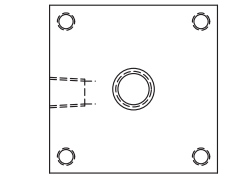
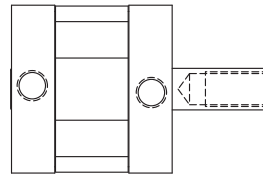

END OF SHAFT TAP

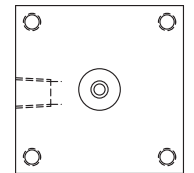
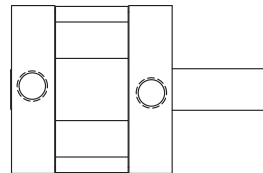

NO KEYWAY

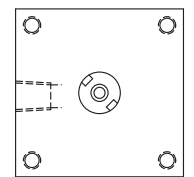
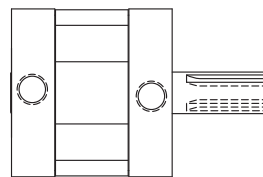

DOUBLE KEYWAY

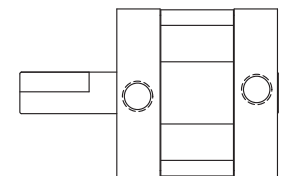
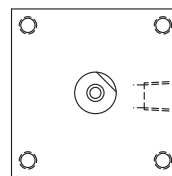

SET SCREW FLAT

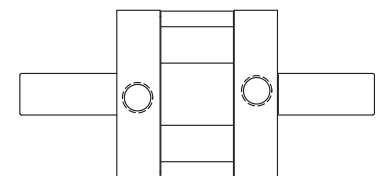
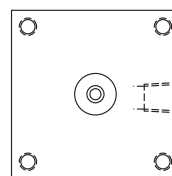

DOUBLE END

Options- Shaft Accessories- Trantorque®

Trantorque

Trantorque keyless shaft couplings eliminates:

- The need for keys, keyways and setscrews.
- Simplifies synchronization.
- Allows for infinite radial adjustments.
- Mounts hubless devices.

The Trantorque coupling uses 2 opposing tapers that expand into the OD and contract on the ID to attach and hold shaft loads.

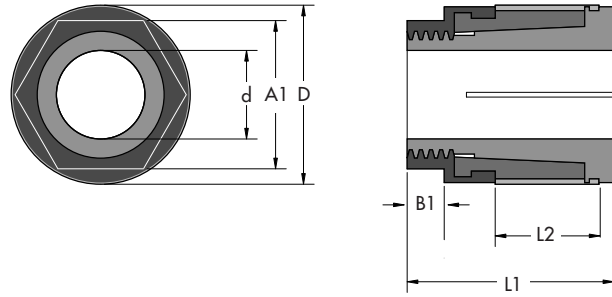

NON-TRAVERSING

| Style | Trantorque Series | | Part # | Actuator Shaft Diameter (d) | Component Bore (D) | Max. Transmissible | | Dimensions | | | | | |
|----------------|-------------------|---------------------------------|---------|-----------------------------|--------------------|--------------------|-----------|------------|--------|--------|--------|-------|-------|
| | | | | | | Tq. | Thrust | L1 | L2 | A1 | A2 | B1 | B2 |
| Non-Traversing | Imperial Mini | Comp-Act Series 1-1/4" Bore OEM | 6980109 | 3/8" | 3/4" | 175 in. lbs. | 648 lbs. | 1-3/16" | 7/16" | 5/8" | NA | 1/8" | N/A |
| | Imperial Series | 1-1/4" Bore Turn-Dex | 6980120 | 5/8" | 1-1/2" | 1225 in. lbs. | 2310 lbs. | 1-21/32" | 11/16" | 1-1/4" | 1-1/2" | 5/16" | 5/16" |
| | | Turn-Act Series 2-1/2" Bore OEM | 6980160 | 3/4" | 1-1/2" | 1750 in. lbs. | 3080 lbs. | 1-21/32" | 11/16" | 1-1/4" | 1-1/2" | 5/16" | 5/16" |
| | | 2-1/2" Bore Turn-Dex | 6980240 | 1" | 1-3/4" | 2450 in. lbs. | 4620 lbs. | 2-1/32" | 13/16" | 1-1/2" | 1-3/4" | 7/16" | 3/8" |
| | | Brute Series | 6980320 | 1-1/4" | 2" | 4200 in. lbs. | 5950 lbs. | 2-13/32" | 15/16" | 1-3/4" | 2" | 1/2" | 9/16" |

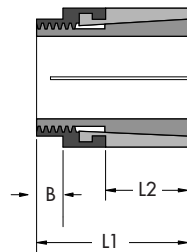
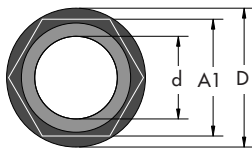

MINI SERIES

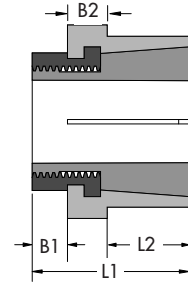
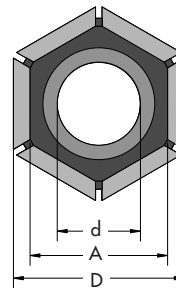

GT SERIES

| Style | Trantorque Series | | Standard Part # | Stainless Steel Part # | Actuator Shaft Diameter (d) | Component Bore (D) | Standard Unit Max. Transmissible | | Stainless Units Max. Transmissible | | Dimensions | | | | | |
|-----------------------|-------------------|---------------------------------|-----------------|------------------------|-----------------------------|--------------------|----------------------------------|-----------|------------------------------------|------------|------------|---------|--------|---------|-------|---------|
| | | | | | | | Tq. | Thrust | Tq. | Thrust | L1 | L2 | A1 | A2 | B1 | B2 |
| Standard or Stainless | Imperial Mini | Comp-Act Series 1-1/4" Bore OEM | 6202109 | 6990109 | 3/8" | 3/4" | 250 in. lbs. | 925 lbs. | 75 lbs. | 280 lbs. | 7/8" | 7/16" | 5/8" | N/A | 1/8" | N/A |
| | Imperial Series | 1-1/4" Bore Turn-Dex | 6202120 | 6990112 | 5/8" | 1-1/2" | 1750 in. lbs. | 3300 lbs. | 525 in. lbs. | 990 1-1/2" | 1-1/2" | 3/4" | 1-1/4" | 1-1/2" | 5/16" | 5/16" |
| | | Turn-Act Series 2-1/2" Bore OEM | 6202160 | 6990160 | 3/4" | 1-1/2" | 2500 in. lbs. | 4400 lbs. | 750 in. lbs. | 1320 lbs. | 1-1/2" | 3/4" | 1-1/4" | 1-1/2" | 5/16" | 5/16" |
| | | 2-1/2" Bore Turn-Dex | 6202240 | 6990240 | 1" | 1-3/4" | 3500 in. lbs. | 6600 lbs. | 1050 in. lbs. | 1980 lbs. | 1-7/8" | 7/8" | 1-1/2" | 1-3/4" | 7/16" | 3/8" |
| | | Brute Series | 6202320 | 6990320 | 1-1/4" | 2" | 6000 in. lbs. | 8500 lbs. | 1800 in. lbs. | 2550 lbs. | 2-1/4" | 1 | 1-3/4" | 2 | 1/2" | 9/16" |
| Metric | Metric Mini | Comp-Act Series 1-1/4" Bore OEM | 620268 | Consult Factory | 8 mm | 19 mm | 23 N-m | 4.0 Kn | Consult Factory | | 22 mm | 11 mm | 16 mm | N/A | 3 mm | N/A |
| | Metric GT Series | Turn-Act Series 2-1/2" Bore OEM | 6202770 | | 17 mm | 38 mm | 220 N-m | 17 Kn | | | 38 mm | 19 mm | 32 mm | 38,1 mm | 8 mm | 8 mm |
| | | Brute Series | 6202835 | | 30 mm | 51 mm | 580 N-m | 35.4 Kn | | | 57 mm | 25,5 mm | 46 mm | 50,8 mm | 13 mm | 14,5 mm |

Shaft Accessories-Trantorque (cont.)

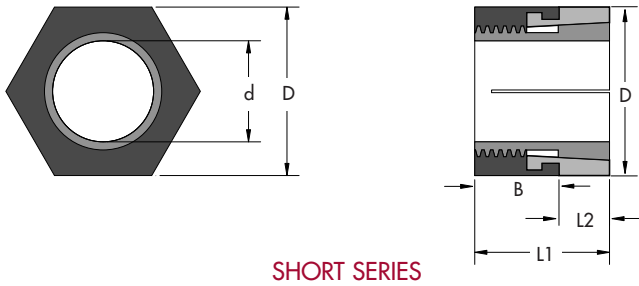

SHORT SERIES

| Style | Trantorque Series | | Part # | Actuator Shaft Diameter (d) | Component Bore (D) | Max. Transmissible | | Dimensions | | | |
|--------------|-------------------|------------------------------------|---------|-----------------------------|--------------------|--------------------|-----------|------------|------|--------|------|
| | | | | | | Tq. | Thrust | L1 | L2 | A | B |
| Short Series | Imperial Mini | Comp-Act Series 1-1/4" Bore OEM | 6940109 | 3/8" | 3/4" | 250 in. lbs. | 925 lbs. | 5/8" | 1/4" | 3/4" | 3/8" |
| | | 1-1/4" Bore Turn-Dex | 6940120 | 5/8" | 1-1/2" | 1750 in. lbs. | 3300 lbs. | 1-1/4" | 1/2" | 1-1/2" | 3/4" |
| | Imperial Series | Turn-Act Series 2-1/2" Bore OEM | 6940160 | 3/4" | 1-1/2" | 2500 in. lbs. | 4400 lbs. | 1-1/4" | 1/2" | 1-1/2" | 3/4" |
| | | 2-1/2" Bore Turn-Dex | 6940240 | 1" | 1-3/4" | 3500 in. lbs. | 6600 lbs. | 1-1/4" | 1/2" | 1-1/4" | 3/4" |
| | | Brute Series | 6940320 | 1-1/4" | 2" | 6000 in. lbs. | 8500 lbs. | 1-1/4" | 1/2" | 2" | 3/4" |

Options- Shaft Accessories- Hub Adapter

This option provides an alternative to the conventional output shaft. The Hub Adapter option allows for easy mounting of grippers, tooling, actuators, cylinders and other end effectors that require a flat mounting surface.

The Hub is manufactured of aluminum with 4 counter bored through holes on one side and threaded holes on other. Trantorque (see Trantorque section) is used in mounting of the Hub Adapter to the actuator shaft. This attachment method provides infinite hub/hole orientation.

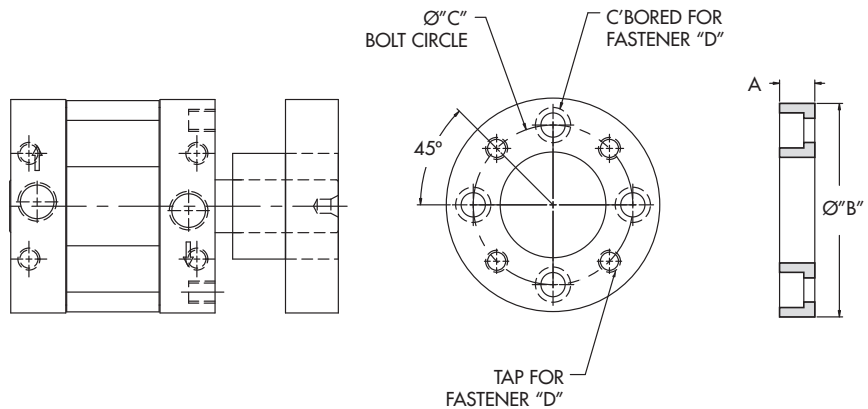

TRANTORQUE WITH ADAPTER HUB

| Option # | Description |
|----------|------------------------------|
| M10 | W/Mild Steel Trantorque |
| M20 | W/Stainless Steel Trantorque |

| Hub Adapter Dimensions | Comp-Act (CA) Series | Turn-Act (TA) Series | Brute Series |
|------------------------|----------------------|----------------------|--------------|
| A | 0.438" | 0.750" | 1.000" |
| B | 1.563" | 2.500" | 5.000" |
| C | 1.156" | 2.000" | 3.656" |
| D | #10-24 | 1/4-20 | 1/2-13 |

NOTE: Contact Factory for other hub diameters, bolt hole patterns, etc.

3 Position Actuator Systems

The Turn-Act Three Position Actuator System utilizes a control actuator, output actuator, and a set of stop cams to achieve the desired rotation.

The two actuators (control & output) are mounted on a common plate. The single end control actuator (see drawing) is located at the back of the assembly. The double end output actuator is located at the front of the assembly. Stop cams are mounted on the rear shaft of the output actuator and the front shaft of the control actuator. These cams allow the control actuator to restrict the motion of the output actuator by rotating a stop into an interference mid-stroke position. When the control actuator rotates the stop cam out of the interference position the output actuator is free to rotate to its end of stroke. Adjustable stroke control permits precise mid and end of stroke positioning. Unlike other 3 position systems, the TURN-ACT system has ZERO backlash and is 100% repeatable in all stop positions.

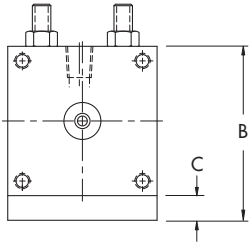

COMP-ACT (CA) 3 POSITION SYSTEM

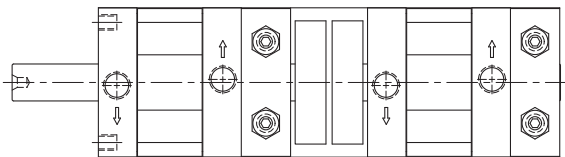

3 POSITION SYSTEM CAMS

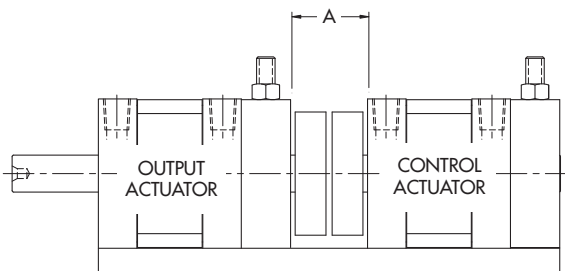

TYPICAL 3 POSITION SYSTEM

Consult factory for application needs.

| Model | A | B | C |
|-------|-------|-------|------|
| CA | 1.040 | 2.000 | .375 |
| TA | 1.562 | 3.530 | .500 |
| BR | 5.750 | 6.750 | .750 |

NOTE: Overall length of the 3 Position System is determined by adding the (A) to the combined length of the actuators selected.

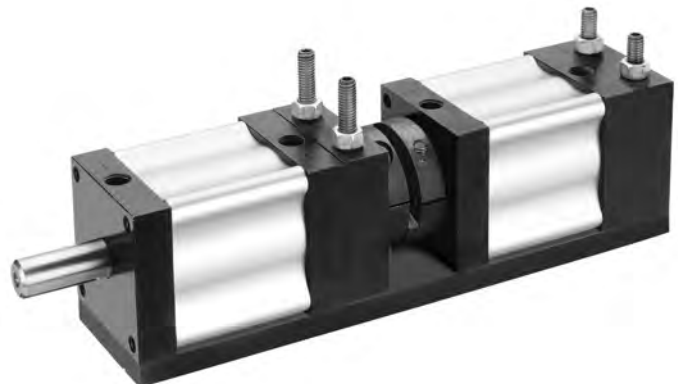

TURN-ACT (TA) 3 POSITION SYSTEM

Hydraulic Service Rotary Actuators

Turn-Act Rotary Actuators can be ordered with modifications for use only in **low-pressure, non-shock** hydraulic applications.

Hydraulic pressure shock is a common phenomenon of hydraulic systems, and is the most common cause of actuator failure. The actuator must be isolated from this shock or damage may occur. Proper hydraulic system design is a requirement for Hydraulic Service Rotary Actuators, and must include pressure-reducing valves for each actuator in use, in addition to normal system pressure relief valves.

Consult factory for the required modifications for hydraulic applications. This option includes:

- Head drain ports
- Modified rotor assembly
- Modified seal configuration
- Heat treated/hardened shaft

Hydraulic Service Rotary Actuators are available in the Comp-Act and Turn-Act series. The allowable pressures are listed below:

- Comp-Act** 200 psi for all sizes
Turn-Act 500 psi for size 1 & 2

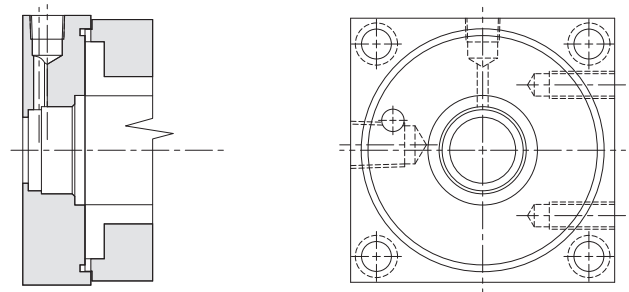
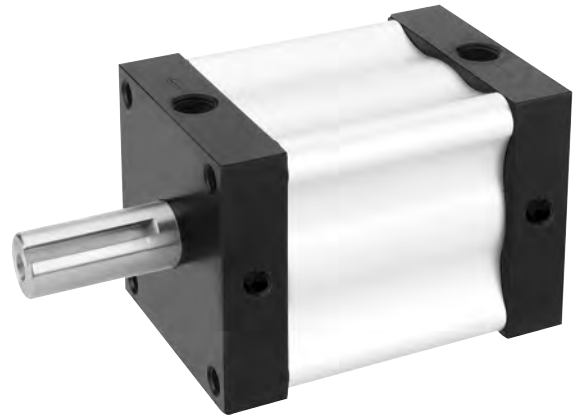

HYDRAULIC DRAIN PORT DETAIL

Clean-Series Option

Turn-Act Rotary Vane Actuators offer distinct advantages over linear cylinders in clean room applications. Below is a comparison of design and operation issues of both cylinders and vane actuators. Also included is general information regarding how contaminants can be introduced into clean environments.

The Clean-Series option has been developed for use in environments that are contamination sensitive. Contamination can occur through multiple methods:

1. Introduction of contamination via cylinder external leakage.

Linear air cylinders have external sliding parts that may have slight air leakage from the piston rod. During extension and retraction the piston rod can introduce contaminants into the clean room by pulling lubricants out of the cylinder past rod seals and wipers. The lubrication required for these cylinders to perform properly is a primary source of contamination.

2. Contaminant Formation caused by abrasion.

Contaminants can be formed through abrasion of cylinder moving components during operation.

3. Components not properly degreased and packaged after manufacture.

Failure to properly clean and degrease components after assembly and test will introduce contamination. Additionally, packaging with improper materials can further result in introduction of contaminants into the clean environment.

Turn-Act Rotary Vane Actuator WITH the Clean Series Option addresses these contamination issues through:

1. Minimization of potential external leakage.

The design of Turn-Act Rotary Vane Actuators inherently minimizes the potential of external contamination from lubricants.

The shaft/rod of a vane actuator does not retract into, or extend out of the air chamber. In a Rotary Vane Actuator the rod rotates outside of the lubricated air cylinder. This results in a minimization of lubricant related contamination. Additional actuator modification can further reduce the incidence of contamination. A secondary, rod head, vacuum port, positioned between inner and outer rod-packings, permits the use of vacuum to exhaust potential contamination outside of the clean room.

2. Reduce abrasion contaminant formation.

Turn-Act's selection of non-contaminating anodized aluminum surfaces, Delrin® bearings, stainless steel shafting and alternative lubricants reduces the likelihood of contamination formation through the abrasive action during operation of the actuator.

3. Proper Cleaning and degreasing.

Turn-Act thoroughly de-greases and cleans actuators with non-contaminating compounds bagged and sealed for shipment in anti static packaging. This choice of materials for the cylinder surfaces, bearings and shafting further minimizes the introduction of contamination in clean rooms.

The nature of a rotary actuator, permits any tooling to be rotated in front of the work surface as opposed to linear cylinders where the rod is typically directed at the work surface. This design factor further minimizes the potential of external contamination being directed at the clean room work surfaces.

Proper Clean Room Design will contribute to the overall minimization of contamination. When possible, pneumatic components should be mounted below and as far from the work surface as practical.



**EØ1-CLEAN-SERIES ACTUATOR/
COMP-ACT (CA)**

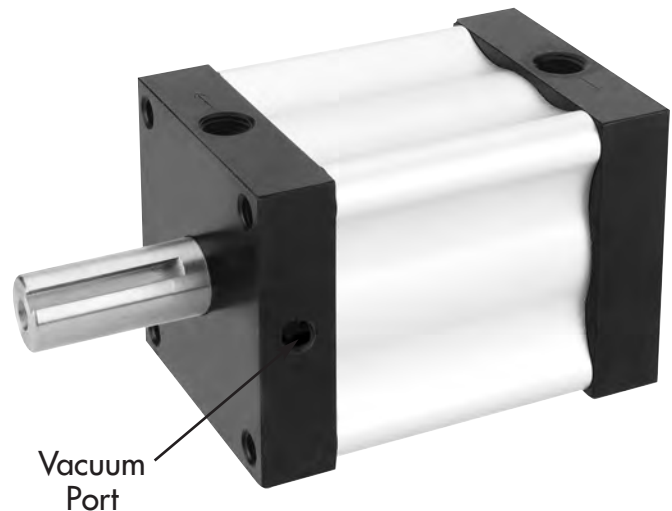

**SPECIAL-CLEAN-SERIES ACTUATOR/
TURN-ACT (TA)**

NOTE: Turn-Act Rotary Vane Actuators are suitable and compatible for most clean-room applications. For "Class I" and "Class X" applications please consult the factory.

Systems

Turn-Act Rotary Vane Actuators can be combined with other Turn-Act products to create multiple axis systems.

- Guided Rod Cylinder
- NFPA Cylinders
- Rotary Actuators
- Multi-Act

LINEAR SYSTEMS:

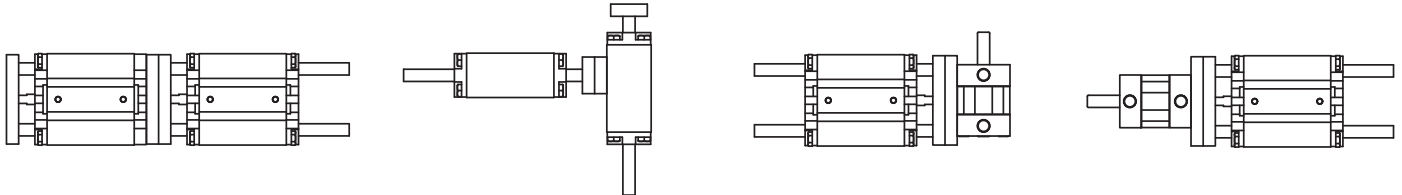

(A) INLINE LINEAR

(B) PERPENDICULAR LINEAR

(C) PERPENDICULAR ROTARY

(D) INLINE ROTARY

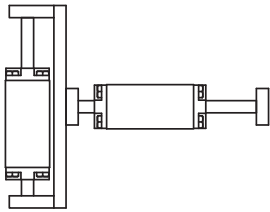

(E) WITH BRIDGEPLATE MOUNTED LINEAR

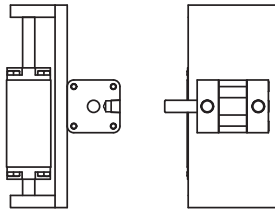

(F) WITH BRIDGEPLATE MOUNTED ROTARY

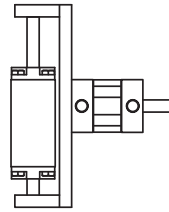

(G) WITH BRIDGEPLATE MOUNTED ROTARY

ROTARY SYSTEMS:

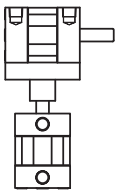

(H) PERPENDICULAR ROTARY

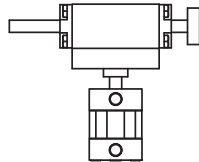

(I) PERPENDICULAR LINEAR

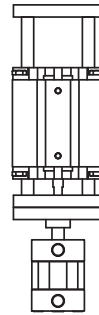

(J) INLINE LINEAR

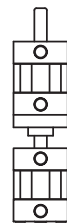

(K) INLINE ROTARY

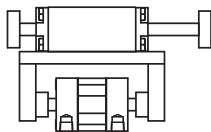

(L) WITH BRIDGEPLATE MOUNTED LINEAR

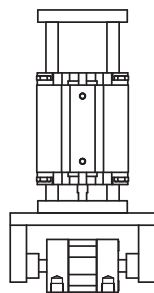

(M) WITH BRIDGEPLATE MOUNTED LINEAR

Consult factory for application information.

Turn-Dex 1-1/4" Bore

ROTARY VANE ACTUATORS with integral unidirectional clutch:

- 6 base models with torque outputs from 13 in. lbs. to 60 in. lbs.
- Clockwise or Counterclockwise stepped rotations.
- Adjustable Stroke Control is standard.

Turn-Dex Stepper Indexer:

- Highly repeatable (+/- 1/2 degree)*.
- Provide instantaneous and continuous full torque.
- Produce more torque in less space.
- Eliminates gears and pivot points that wear, break or strip.
- Patented Urethane seals for:
 - Long cycle life and Non-lube service.
 - Actual applications with 25 million cycles and more.
- 100s of standard options and modifications.

Just imagine... How Answer Engineering can work for you!



**TURN-DEX ACTUATOR WITH ADJUSTABLE STROKE CONTROL (STD)
SHOWN WITH OPTION 801 (SIDE MOUNTS POS. 2 & 6)**

| Torque Chart (IN LBS.) | | | |
|--------------------------------------|--------------------|--------|--------|
| 180° and 270° Rotations ² | | | |
| Actuator Model | Actuator Torque at | | |
| | 100 PSI | 80 PSI | 60 PSI |
| 321 | 13 | 10 | 7 |
| 323 | | | |
| 341 | 32 | 25 | 19 |
| 343 | | | |

| Torque Chart (IN LBS.) | | | |
|----------------------------|--------------------|--------|--------|
| 90° Rotations ² | | | |
| Actuator Model | Actuator Torque at | | |
| | 100 PSI | 80 PSI | 60 PSI |
| 322 | 25 | 20 | 15 |
| 342 | 60 | 48 | 36 |

***NOTE:**

Overrun:

The output shaft can be manually rotated only in its drive direction. Large loads may coast after the actuator has stopped. The output shaft cannot be reverse rotated. Forcing it backwards could damage the Turn-Dex.

Accurate & Repeatable Positioning:

Due to the overrun nature of the clutch, external stops, brakes, roller and detents or shot-pins are required for accurate and repeatable positioning.

SPECIFICATIONS

Unit Materials

Stator/Rotor Seals ...Urethane
Shaft/Tube SealsBuna¹
Shaft1144 G&P Steel
BodyAnodized Alum.
BearingsFull Comp. Needle

Miscellaneous

Inlets1/8 NPT
Min. Pressure35 psi
Max. Pressure200 psi
Cylinder Bore1-1/4"

Shaft Load Capacities

Max. Side Load125 lbs.
Max. End Load10 lbs.

Temperature Range

40°F to 180°F
For applications below 40°F, a variety of seal options are available based upon cycle rates, temperatures and frequency of use. Consult the factory to discuss your cold temperature application for your optimum solution.

Filtration

Air 25-50 microns

Clutch

TypeRoller, lock in one direction, free overrun in other direction.
Max. Torque Rating...143 in. lbs.

Cycle Rates³

Max. non-lubed rate:
Double Vane40 cpm
Single Vane20 cpm

Max. lubed rate:
Consult Factory

Rotary Motion Backlash

All models0 degree

Leak Rates

Air 4 cfm or less@100 psi

1. Viton Optional
2. All rotations are nominal +4/-0 actual
3. Cycle = Start position to end of rotation and returning to the start position.
Stroke = 1/2 cycle

| Capacity per Stroke ³ (IN ³) | | | |
|---|------|---------------------------|------|
| 270° Rotation ² | | 90° Rotation ² | |
| 321 | 0.99 | 322 | 0.84 |
| 341 | 1.99 | 342 | 1.68 |

| Weights (OZs) | | | |
|----------------------------|----|---------------------------|----|
| 270° Rotation ² | | 90° Rotation ² | |
| 321 | 10 | 322 | 10 |
| 341 | 14 | 342 | 14 |

How to Order: Turn-Dex 1-1/4" Bore



1

| Model | | | |
|-------|--------|--------|----------|
| Model | Bore | Torque | Rotation |
| 321 | 1-1/4" | 13 | 270 |
| 322 | 1-1/4" | 25 | 90 |
| 323 | 1-1/4" | 13 | 180 |
| 341 | 1-1/4" | 32 | 270 |
| 342 | 1-1/4" | 60 | 90 |
| 343 | 1-1/4" | 32 | 180 |

2

| Drive Direction | |
|--|-------------------|
| Based on shaft end view and inlets at 12 O'Clock | |
| 1 | Clockwise |
| 2 | Counter-clockwise |

3

| Options | |
|---------------------------------------|---|
| Additional options available on pg. 9 | |
| Option # | Description |
| 000 | No Options |
| 100 | Front Flange |
| 101 | Rear Flange |
| 200 | Side Angle Brackets, Mounting Surface 3 & 7 |
| 201 | Side Angle Brackets, Mounting Surface 2 & 6 |
| 202 | Side Angle Brackets, Mounting Surface 4 & 8 |
| 203 | Side Angle Brackets, Mounting Surface 1 & 5 |
| 800 | Side Mounts, Sides 1 & 5 |
| 801 | Side Mounts, Sides 2 & 6 |
| 803 | Side Mounts, Sides 4 & 8 |
| 804 | Side Mounts, Sides 2, 4, 6 & 8 |
| 806 | Side Mounts, Sides 6 & 8 |
| 807 | Side Mounts, Sides 2 & 4 |
| 810 | No Bottom Mounts |
| Cap Sensor Options (See pg. 13) | |
| A00 | Sensor System – No Sensors |
| A05 | Sensor System – 2 Sourcing Sensors |
| A08 | Sensor System – 2 Sinking Sensors |
| A02 | Sensor System – 2 Reed Sensors |
| A25 | Sensor System – 2 Sourcing Sensors* |
| A28 | Sensor System – 2 Sinking Sensors* |
| A22 | Sensor System – 2 Reed Sensors* |

*NOTE: See page 13 for Lead Type variation

Dimensional Data: Turn-Dex 1-1/4" Bore

Basic Dimensions

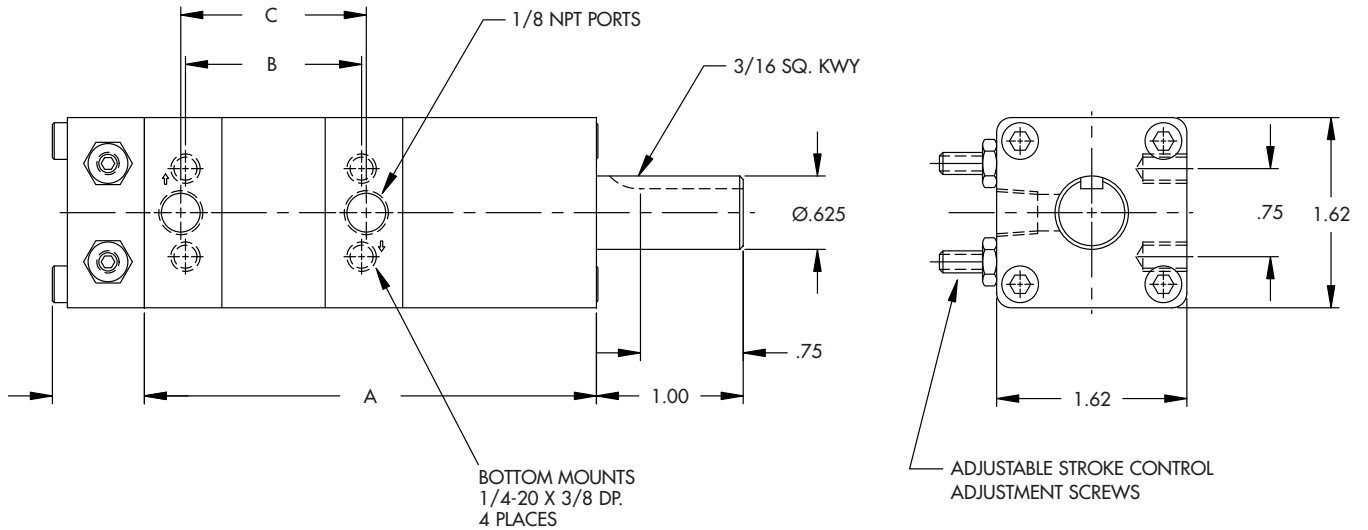

Dimensional Specifications

| Actuator | A | B | C |
|------------|------|------|------|
| 321 | 3.84 | 1.50 | 1.57 |
| 322 | 3.84 | 1.50 | 1.57 |
| 323 | 3.84 | 1.50 | 1.57 |
| 341 | 4.84 | 2.50 | 2.57 |
| 342 | 4.84 | 2.50 | 2.57 |
| 343 | 4.84 | 2.50 | 2.57 |

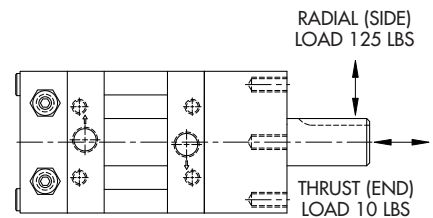
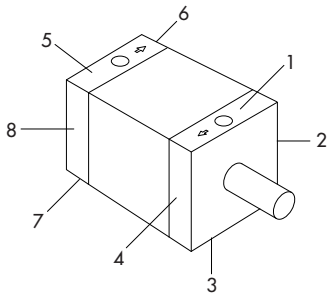

Port & Mounting Position References

Shaft Load Capacity

Turn-Dex 2-1/2" Bore

ROTARY VANE ACTUATORS with integral unidirectional clutch:

- 10 base models with torque outputs from 87 in. lbs. to 350 in. lbs.
- Clockwise or Counterclockwise stepped rotations.
- Adjustable Stroke Control is standard.

Turn-Dex Stepper Indexer:

- Highly repeatable (+/- 1/2 degree)*.
- Provide instantaneous and continuous full torque.
- Produce more torque in less space.
- Eliminates gears and pivotpoints that wear, break or strip.
- Patented Urethane seals for:
 - Long cycle life and Non-lube service.
 - Actual applications with 25 million cycles and more.
- 100s of standard options and modifications.

Just imagine... How Answer Engineering can work for you!



TURN-DEX ACTUATOR WITH ADJUSTABLE STROKE CONTROL (STD)

| Torque Chart (IN. LBS.) | | | |
|--------------------------------------|--------------------|--------|--------|
| 180° and 270° Rotations ² | | | |
| Actuator Model | Actuator Torque at | | |
| | 100 PSI | 80 PSI | 60 PSI |
| 411 | 87 | 70 | 52 |
| 413 | | | |
| 421 | 175 | 140 | 105 |
| 423 | | | |
| 431 | 350 | 280 | 210 |
| 433 | | | |

| Torque Chart (IN. LBS.) | | | |
|------------------------------------|--------------------|--------|--------|
| 45° AND 90° Rotations ² | | | |
| Actuator Model | Actuator Torque at | | |
| | 100 PSI | 80 PSI | 60 PSI |
| 412 | 175 | 140 | 105 |
| 414 | | | |
| 422 | 350 | 280 | 210 |
| 424 | | | |

***NOTE:**

Overrun:

The output shaft can be manually rotated only in its drive direction. Large loads may coast after the actuator has stopped. The output shaft cannot be reverse rotated. Forcing it backwards could damage the Turn-Dex.

Accurate & Repeatable Positioning:

Due to the overrun nature of the clutch, external stops, brakes, roller and detents or shot-pins are required for accurate and repeatable positioning.

SPECIFICATIONS

Unit Materials

Stator/Rotor Seals...Urethane
 Shaft/Tube SealsBuna¹
 Shaft1 1/4 G&P steel
 Body.....Anodized Alum.
 Bearings ...Full Comp. Needle

Miscellaneous

Inlets.....1/4 NPT
 Min. Pressure35 psi
 Max. Pressure200 psi⁴
 Cylinder Bore2-1/2"

Shaft Load Capacities

Max. Side Load.....250 lbs.
 Max. End Load.....25 lbs.

Temperature Range

40°F to 180°F
 For applications below 40°F, a variety of seal options are available based upon cycle rates, temperatures and frequency of use. Consult the factory to discuss your cold temperature application for your optimum solution.

Filtration

Air25-50 microns

Clutch

Type.....Roller, lock in one direction, free overrun in other direction

Max. Torque Rating...412 in. lbs.

Cycle Rates³

Max. non-lubed rate:

Double Vane40 cpm
 Single Vane20 cpm

Max. lubed rate:

Consult Factory

Rotary Motion Backlash

All models0 degree

Leak Rates

Air.....4 cfm or less@100 psi

1. Viton Optional
2. All rotations are nominal +4/-0 actual
3. Cycle = Start position to end of rotation and returning to the start position.
Stroke = 1/2 cycle
4. Pressure Rating for 41X and 42X is 500 psi max.

| Capacity per Stroke ³ (IN ³) | | | | |
|---|----------------------------|------|---------------------------|------|
| | 270° Rotation ² | | 90° Rotation ² | |
| | 411 | 4.52 | 412 | 2.75 |
| 421 | 8.50 | 422 | 5.50 | |
| 431 | 17.0 | N/A | N/A | |

| Weights (LBS.) | | | | |
|----------------|----------------------------|-----|---------------------------|-----|
| | 270° Rotation ² | | 90° Rotation ² | |
| | 411 | 2.5 | 412 | 2.5 |
| 421 | 3.3 | 422 | 3.5 | |
| 431 | 6.0 | N/A | N/A | |

How to Order: Turn-Dex 2-1/2" Bore

DRIVE
MODEL DIRECTION OPTIONS OPTIONS
413 - 2 - 200 - XXX
1 2 3 3

1

| Model | | | |
|-------|--------|--------|----------|
| Model | Bore | Torque | Rotation |
| 411 | 2-1/2" | 87 | 270 |
| 412 | 2-1/2" | 175 | 90 |
| 413 | 2-1/2" | 87 | 180 |
| 414 | 2-1/2" | 175 | 45 |
| 421 | 2-1/2" | 175 | 270 |
| 422 | 2-1/2" | 350 | 90 |
| 423 | 2-1/2" | 175 | 180 |
| 424 | 2-1/2" | 350 | 45 |
| 431 | 2-1/2" | 350 | 270 |
| 433 | 2-1/2" | 350 | 180 |

2

| Drive Direction | |
|--|-------------------|
| Based on shaft end view and inlets at 12 O'Clock | |
| 1 | Clockwise |
| 2 | Counter-clockwise |

3

| Options | |
|---------------------------------------|---|
| Additional options available on pg. 9 | |
| Option # | Description |
| 000 | No Options |
| 100 | Front Flange |
| 101 | Rear Flange |
| 200 | Side Angle Brackets, Mounting Surface 3 & 7 |
| 201 | Side Angle Brackets, Mounting Surface 2 & 6 |
| 202 | Side Angle Brackets, Mounting Surface 4 & 8 |
| 203 | Side Angle Brackets, Mounting Surface 1 & 5 |
| 800 | Side Mounts, Sides 1 & 5 |
| 801 | Side Mounts, Sides 2 & 6 |
| 803 | Side Mounts, Sides 4 & 8 |
| 804 | Side Mounts, Sides 2, 4, 6 & 8 |
| 806 | Side Mounts, Sides 6 & 8 |
| 807 | Side Mounts, Sides 2 & 4 |
| 810 | No Side Mounts |
| 900 | Cap End |
| Cap Sensor Options (See pg. 13) | |
| A00 | Sensor System - No Sensors |
| A05 | Sensor System - 2 Sourcing Sensors |
| A08 | Sensor System - 2 Sinking Sensors |
| A02 | Sensor System - 2 Reed Sensors |
| A25 | Sensor System - 2 Sourcing Sensors* |
| A28 | Sensor System - 2 Sinking Sensors* |
| A22 | Sensor System - 2 Reed Sensors* |

*NOTE: See page 13 for Lead Type variation

Dimensional Data: Turn-Dex 2-1/2" Bore

Basic Dimensions

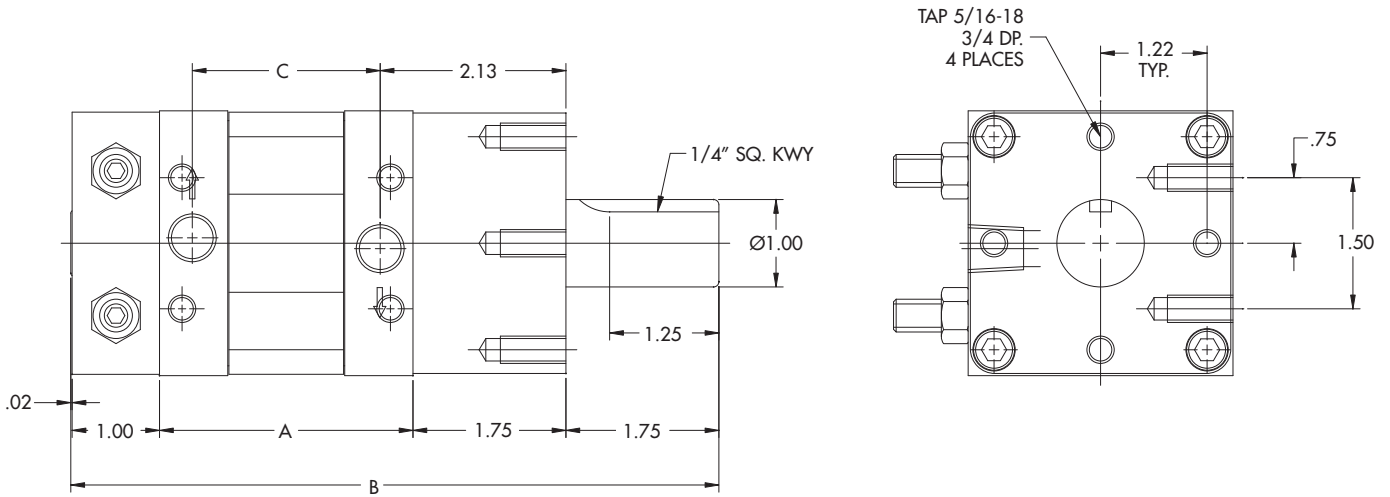

Dimensional Specifications

| Actuator | A | B | C | D |
|----------|-------|-------|------|------|
| 41X | 2.90 | 7.40 | 2.15 | 2.38 |
| 42X | 4.40 | 8.90 | 3.64 | 3.88 |
| 43X | 7.42 | 11.92 | 6.67 | 6.91 |
| 44X | 10.38 | 14.88 | 9.63 | 9.86 |

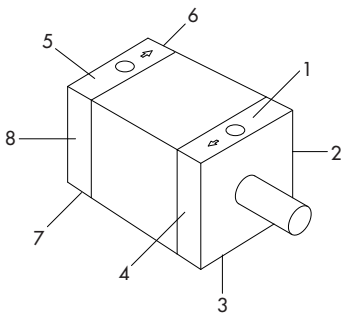

Port & Mounting Position References

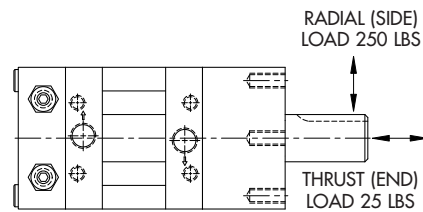

Shaft Load Capacity

Adjustable Stroke Control (ASC)

Standard on all Turn-Dex models, the Adjustable Stroke Control (ASC) allows an actuator to be adjusted to the exact rotational stroke desired. The ASC consists of a shaft mounted steel cam, enclosed in a housing with adjustment screws (see method of operation below). Turning the adjustment screws either extends or limits the amount of rotation. The ends of the adjustment screws impact the cam providing a positive and repeatable end of rotation stop. The ASC option is often specified for applications where the stroke required is not within the rotational tolerance. The standard rotational stroke tolerance of an actuator is $+4^\circ / -0^\circ$. (i.e.: A 90° actuator without ASC will have a rotation of 90° - 94° . With the addition of the ASC option a precise 90° rotation is attainable.)



| Option # | Description |
|----------|-------------------------|
| 402 | ASC Cap End, Position 6 |
| 404 | ASC Cap End, Position 7 |
| 406 | ASC Cap End, Position 8 |

NOTE: The Thrust Protection Option (see pg 12) is integrated into the ASC Housing.

| Actuator Rotation | Adjusting Range |
|-------------------|-----------------|
| 90° | 0-90 degrees |
| 180° | 90-180 degrees |
| 270° | 90-270 degrees |

NOTE: Rotations greater than 180° are not fully adjustable with a standard 2 screw adjustable stroke control. Consult factory for greater adjustment range.

| Adjustable Stroke Control (ASC) Dimension | | | | |
|---|-------------|---------|-------------|---------|
| MODEL/Bore | (A=max) in. | (B) in. | (C) in. Sq. | (D) in. |
| Turn-Dex 1-1/4" | 1.500 | 0.656 | 1.63 | .13" |
| Turn-Dex 2-1/2" | 3.250 | 1.000 | 3.03 | .10" |

Position Reference Drawing

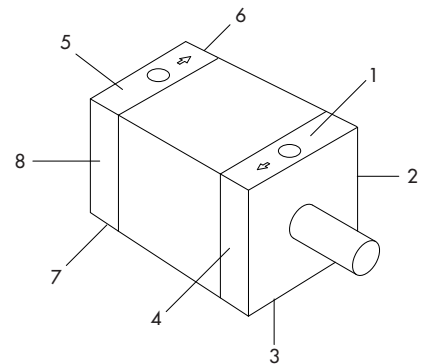

NOTE: Specify the position to be tapped for adjustment screws. Example: Option 407 would call out position 4 as the adjustment screw location, as depicted in the drawing above.

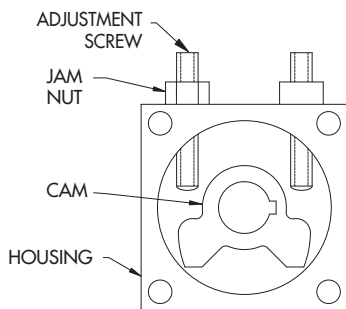

Method of Operation

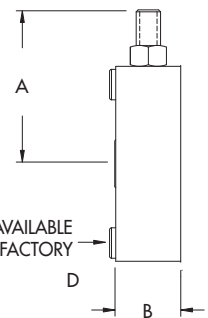
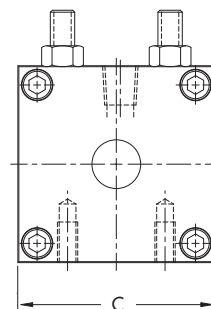

NOTE: FLUSH AVAILABLE
CONSULT FACTORY

Dimensional Data

Turn-Dex Options – Flange Mount

Turn-Dex 1-1/4" Bore

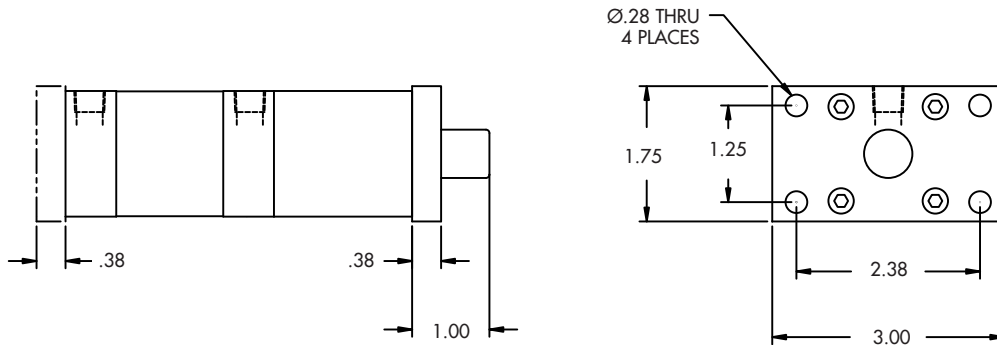

NOTE: ASC is standard on all Turn-Dex models but omitted for clarity.
Side Mounts surface 3 & 7 are standard, but are not shown for clarity.
Please refer to page 4 for dimensional information.

Turn-Dex 2-1/2" Bore

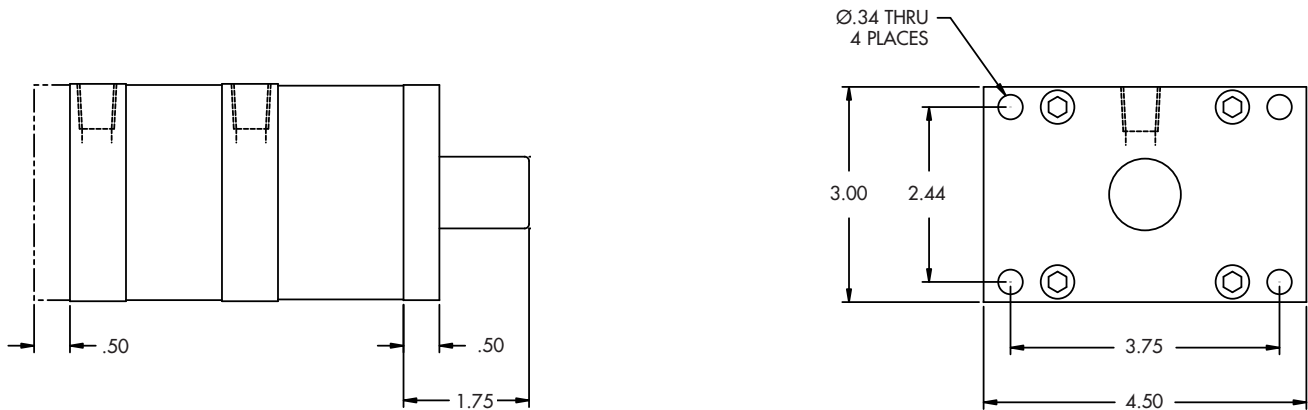

NOTE: ASC is standard on all Turn-Dex models but omitted for clarity.
Side Mounts surface 3 & 7 are standard, but are not shown for clarity.
Please refer to page 7 for dimensional information.

| Option# | Description |
|---------|--------------|
| 100 | Front Flange |
| 101 | Rear Flange |

NOTE: The Flange Mount option and Adjustable Stroke Control option may not be ordered on the same end of a unit. Consult factory for additional flange options.

Turn-Dex Options - Side Angle Mounts

| Option # | Description |
|------------|---|
| 200 | Side Angle Brackets, Mounting Surface 3 & 7 |
| 201 | Side Angle Brackets, Mounting Surface 2 & 6 |
| 202 | Side Angle Brackets, Mounting Surface 4 & 8 |
| 203 | Side Angle Brackets, Mounting Surface 1 & 5 |

NOTE: Specify the surface to be used for mounting. Example: Option 200 would call out surface 3 & 7 as the mounting surface, Option 201 would call out surface 2 & 6 as the mounting surface.

(2-1/2" Bore Only)

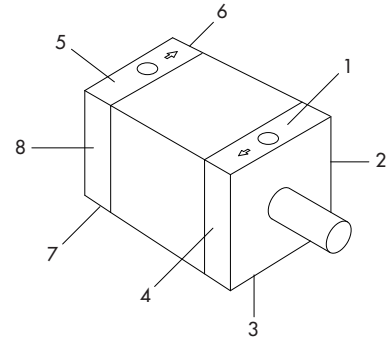

Mounting Surface Reference Drawing

Turn-Dex 2-1/2" Bore

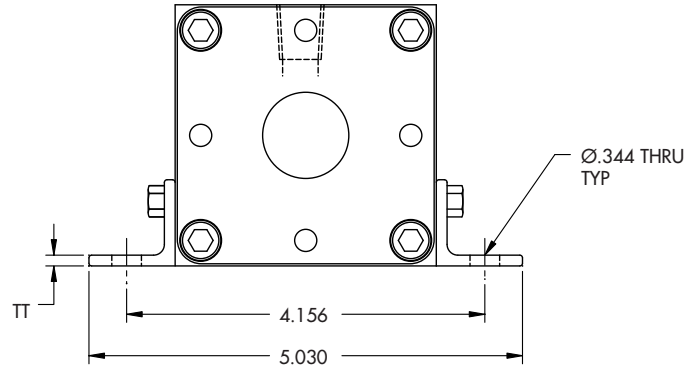
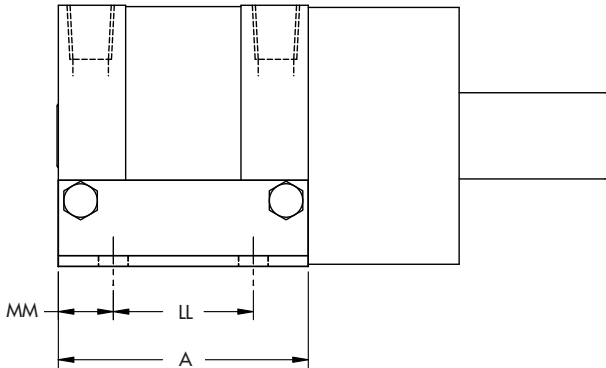

**Option 200
Shown in Drawing**

NOTE: ASC is standard on all Turn-Dex models but omitted for clarity. Please refer to page 7 for dimensional information.

| Turn-Dex Model | A | LL | MM | TT |
|----------------|-------|-------|------|------|
| 41X | 2.90 | 1.625 | .638 | .125 |
| 42X | 4.40 | 3.000 | .694 | .125 |
| 43X | 7.42 | 6.000 | .712 | .119 |
| 44X | 10.38 | 9.125 | .626 | .188 |

Turn-Dex Options - Side Mounts

| Option # | Description |
|--|--------------------------------|
| Side Mounts, Sides 3 & 7 Standard on all Mounts | |
| 800 | Side Mounts, Sides 1 & 5 |
| 801 | Side Mounts, Sides 2 & 6 |
| 803 | Side Mounts, Sides 4 & 8 |
| 804 | Side Mounts, Sides 2, 4, 6 & 8 |
| 806 | Side Mounts, Sides 6 & 8 |
| 807 | Side Mounts, Sides 2 & 4 |
| 810 | No Bottom Mounts |

NOTE:

- Specify the side to be used for mounting. Example: Option 804 would call out sides 2, 4, 6 & 8 as the mounting surfaces, as depicted in the drawings below. Mount sides 3 & 7 are standard on all models but are not shown for clarity.
- ASC is standard on all Turn-Dex models but omitted for clarity. Please refer to page 8 for dimensional information.

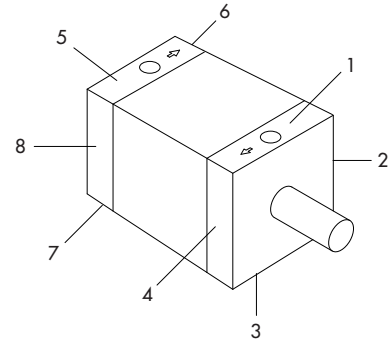

Position Reference Drawing

Turn-Dex 1-1/4" Bore

| Comp-Act Models | D |
|-----------------|------|
| 31X | 1.00 |
| 32X | 1.50 |
| 33X | 2.00 |
| 34X | 2.50 |
| 36X | 4.05 |

NOTE:

- Mounts surface 3 & 7 are standard, but are not shown for clarity. Standard Bottom Mount dimensions shown on page 4.
- ASC is standard on all Turn-Dex models but omitted for clarity. Please refer to page 8 for dimensional information.

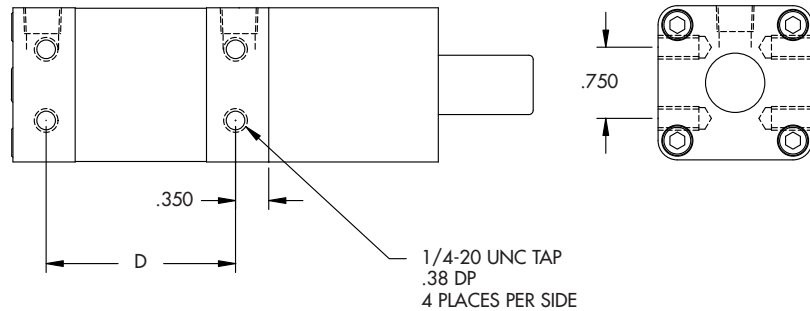

Turn-Dex 2-1/2" Bore

| Turn-Act Models | D |
|-----------------|------|
| 41X | 2.38 |
| 42X | 3.88 |
| 43X | 6.91 |
| 44X | 9.86 |

NOTE:

- Mounts surface 3 & 7 are standard, but are not shown for clarity. Standard Bottom Mount dimensions shown on page 7.
- Center drill omitted from shaft details for clarity.
- ASC is standard on all Turn-Dex models but omitted for clarity. Please refer to page 8 for dimensional information.

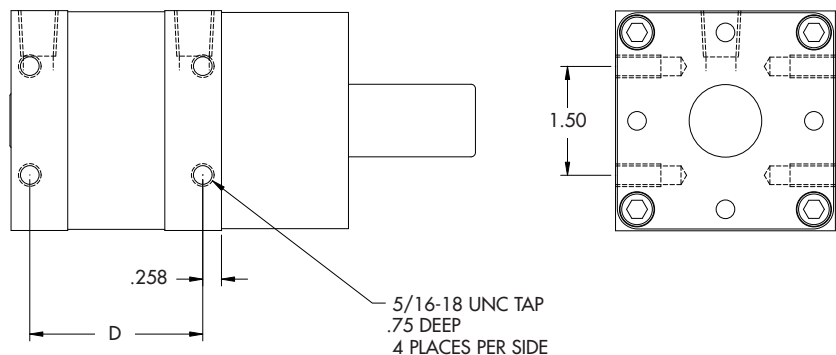

Turn-Dex Options - Thrust Protection

Excessive thrust load will cause premature seal wear and shorten actuator cycle life (See chart below). Applications that produce high linear/thrust loads, such as when the shaft is vertical, with the load set on or hanging from the shaft may require the Thrust Protection option.

This option consists of a series of internal thrust bearings and a shaft collar enclosed in a machined aluminum housing. This system effectively isolates the load from the actuator vane, permitting higher thrust load limits (See chart).



TURN-DEX SERIES ACTUATOR WITH OPTIONAL THRUST PROTECTION.

NOTE: The Adjustable Stroke Control (ASC) Option is integrated into the Thrust Protection Housing.

| Option # | Position |
|----------|----------|
| 901 | Rod End |

APPLICATION CONSIDERATIONS

Overrun:

The output shaft can be manually rotated only in its drive direction. Large loads may coast after the actuator has stopped. The output shaft cannot be reverse rotated. Forcing it backwards could damage the Turn-Dex.

Accurate & Repeatable Positioning:

Due to the overrun nature of the clutch, external stops, brakes, roller and detents or shot-pins are required for accurate and repeatable positioning.

Special Options:

Customized units to fit your specific application needs. Modifications include special shafting, special mounts, clutch housings with shot-pin cylinders, disc brakes and thrust protection. Consult factory for additional information.

Turn-Dex Options - Cap Sensor Systems

Turn-Dex Actuators are available with electronic position sensing sensors. The sensors have LED lamps that light when in sensing position. If adjusted for end of stroke indication, the LED will remain lit as long as the stroke position is maintained. A small shaft mounted magnet in the sensor housing operates the sensors (see drawings).



Sensor System with 8mm Quick Disconnect



Sensor System with 9 ft. Leads

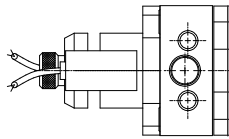

Turn-Dex 1-1/4" Bore Sensors

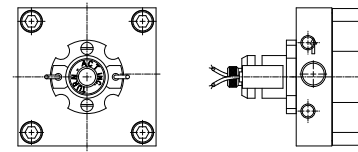
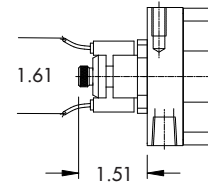

Turn-Dex 2-1/2" Bore Sensors

| SENSOR PACKAGE (CAP END) | | | | | | | |
|---|-------------------------|----------------------|-----------------|---------------------------|-------------------------------|---------------|-------------------|
| Includes a Cap End Mounted Sensor Ready Housing | | | | | | | |
| Option # | Switch Type | Function | Lead Type | Sensing Voltage | Sensing Current | Sensing Power | Max. Voltage Drop |
| A00 | Sensor Ready No Sensors | - | - | - | - | - | - |
| A05 | PNP/Sourcing | Normally Open Output | 22 gauge | 6-24 VDC | 0.5 Amp Max | N/A | 0.5 Volts |
| A08 | NPN/Sinking | Normally Open Output | 22 gauge | 6-24 VDC | 0.5 Amp Max | N/A | 0.5 Volts |
| A02 | AC/DC Reed | SPST Normally Open | 22 gauge | 5-120 VDC/VAC 50/60 Hz | 0.5 Amp Max 0.005 Amp min. | 10 watts Max | 3.5 Volts |
| A25 | PNP/Sourcing | Normally Open Output | 8mm Type - B QD | 6-24VDC | 0.5 Amp Max | N/A | 0.5 Volts |
| A28 | NPN/Sinking | Normally Open Output | 8mm Type - B QD | 6-24VDC | 0.5 Amp Max | N/A | 0.5 Volts |
| A22 | AC/DC Reed | SPST Normally Open | 8mm Type - B QD | 5-120 VDC/VAC 50/60 Hz | 0.5 Amp Max 0.005 Amp min. | 10 watts Max | 3.5 Volts |

Caution: Sensors will be permanently damaged if operated without a load. Consult factory if lead length is lead length will exceed 20 ft.

NOTE: 2 sensors per option.

Turn-Dex Options - Trantorque®

Trantorque

Trantorque keyless shaft couplings eliminates:

- The need for keys, keyways and setscrews.
- Simplifies synchronization.
- Allows for infinite radial adjustments.
- Mounts hubless devices.

The Trantorque coupling uses 2 opposing tapers that expand into the OD and contract on the ID to attach and hold shaft loads.

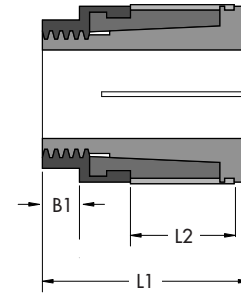
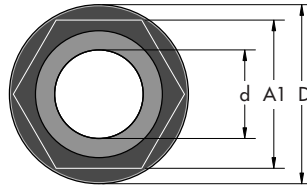

Non-Traversing

| Style | Trantorque Series | Part # | Actuator Shaft Diameter (d) | Component Bore (D) | Max. Transmissible | | Dimensions | | | | | | |
|----------------|-------------------|-----------------|-----------------------------|--------------------|--------------------|--------------|------------|----------|--------|--------|--------|-------|-------|
| | | | | | Tq. | Thrust | L1 | L2 | A1 | A2 | B1 | B2 | |
| Non-Traversing | Imperial Series | Turn-Dex 1-1/4" | 6980120 | 5/8" | 1-1/2" | 1225 in lbs. | 2310 lbs. | 1-21/32" | 11/16" | 1-1/4" | 1-1/2" | 5/16" | 5/16" |
| | | Turn-Dex 2-1/2" | 6980240 | 1" | 1-3/4" | 2450 in lbs. | 4620 lbs. | 2-1/32" | 13/16" | 1-1/2" | 1-3/4" | 7/16" | 3/8" |

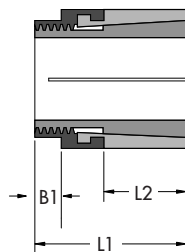
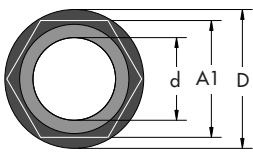

Mini series

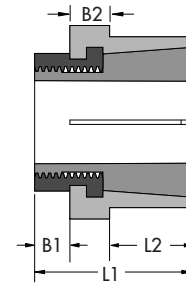
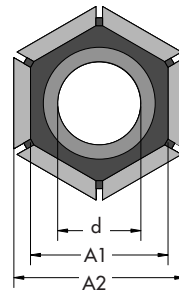

GT series

| Style | Trantorque Series | Part # | Actuator Shaft Diameter (d) | Component Bore (D) | Max. Transmissible | | Dimensions | | | | | | |
|-----------------|-------------------|-----------------|-----------------------------|--------------------|--------------------|--------------|------------|--------|------|--------|--------|-------|-------|
| | | | | | Tq. | Thrust | L1 | L2 | A1 | A2 | B1 | B2 | |
| Standard Models | Imperial Series | Turn-Dex 1-1/4" | 6980120 | 5/8" | 1-1/2" | 1750 in lbs. | 3300 lbs. | 1-1/2" | 3/4" | 1-1/4" | 1-1/2" | 5/16" | 5/16" |
| | | Turn-Dex 2-1/2" | 6980240 | 1" | 1-3/4" | 3500 in lbs. | 6600 lbs. | 1-7/8" | 7/8" | 1-1/2" | 1-3/4" | 7/16" | 3/8" |

| Style | Trantorque Series | Part # | Actuator Shaft Diameter (d) | Component Bore (D) | Max. Transmissible | | Dimensions | | | | | | |
|------------------|-------------------|-----------------|-----------------------------|--------------------|--------------------|--------------|------------|--------|------|--------|--------|-------|-------|
| | | | | | Tq. | Thrust | L1 | L2 | A1 | A2 | B1 | B2 | |
| Stainless Models | Imperial Series | Turn-Dex 1-1/4" | 6980120 | 5/8" | 1-1/2" | 525 in lbs. | 990 lbs. | 1-1/2" | 3/4" | 1-1/4" | 1-1/2" | 5/16" | 5/16" |
| | | Turn-Dex 2-1/2" | 6980240 | 1" | 1-3/4" | 1050 in lbs. | 1980 lbs. | 1-7/8" | 7/8" | 1-1/2" | 1-3/4" | 7/16" | 3/8" |

Turn-Dex Options - Hub Adapter

This option provides an alternative to the conventional output shaft. The Hub Adapter option allows for easy mounting of grippers, tooling, actuators, cylinders and other end effectors that require a flat mounting surface.

The Hub is manufactured of aluminum with 4 counter bored through holes on one side and tapped holes on other. Trantorque (see Trantorque section) is used in mounting of the Hub Adapter to the actuator shaft. This attachment method provides infinite hub/hole orientation.

| Option # | Description |
|----------|------------------------------|
| M10 | W/Carbon Steel Trantorque |
| M20 | W/Stainless Steel Trantorque |

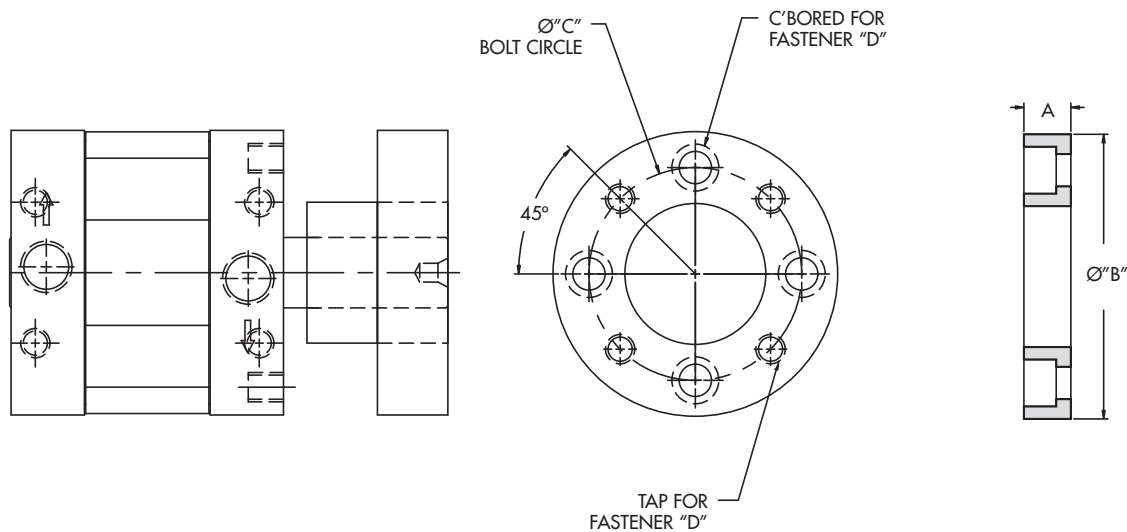

Trantorque with Hub Adapter

| Hub Adapter Dimensions | Turn-Dex 1-1/4" Bore | Turn-Dex 2-1/2" Bore |
|------------------------|----------------------|----------------------|
| A | 0.438" | 0.750" |
| B | 1.563" | 2.500" |
| C | 1.156" | 2.000" |
| D | #10-24 | 1/4-20 |

NOTE: Contact Factory for other hub diameters, bolt hole patterns, etc.

Specifications: Class-Act (CL) Valve Operator (1/4"-3/4")

Double Acting Valve Operator Systems

- Valve Sizes from 1/4" to 3/4"
- 48 in. lbs. to 80 in. lbs.

As compared to other rotary devices, ITT Vane Actuators Have:

- One Moving Part Providing:
 - ZERO Backlash
 - No Loss of Motion
 - Smooth Rotation
 - Precise Repeatability
 - Continuous Full Torque Throughout Rotation
- ITT Patented Urethane Seals for:
 - Long Cycle Life and Non-Lube Service

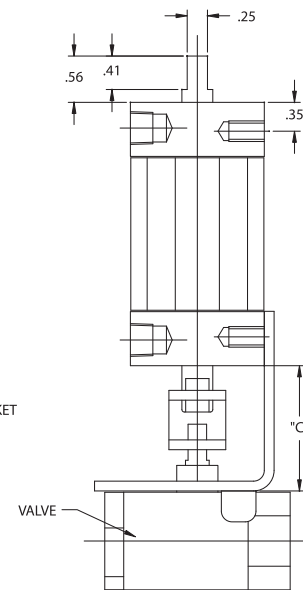
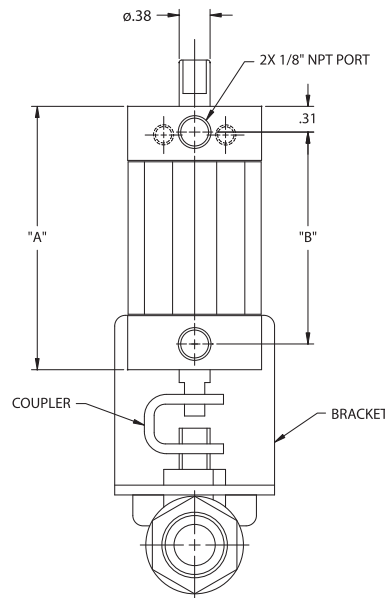
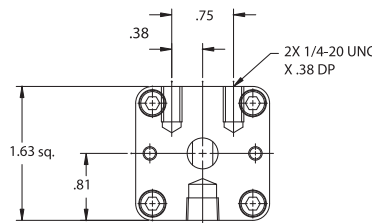

SPECIFICATIONS

Unit Materials

| | |
|-------------------------|------------------------|
| Stator/Rotor Seals..... | Urethane |
| Shaft/Tube Seals | Buna |
| Cylinder | Anodized Alum. |
| End Caps | Anodized Alum. |
| Shaft..... | Stainless Steel |
| Trim | Mild Steel, Opt'l S.S. |
| Bearings | Delrin |
| Brackets..... | Stainless Steel |
| Couplings | Stainless Steel |

Miscellaneous

Inlets.....1/8" NPT

Filtration

Air 25-30 microns

Temperature Range

40°F to 180°F

For applications below 40°F, a variety of seal options are available based upon cycle rates, temperatures and frequency of use. Consult the factory to discuss your cold temperature application for your optimum solution.

Torque Chart (in.lbs.)

| Actuator Model | Actuator Torque at | | | | |
|----------------|--------------------|--------|--------|---------|---------|
| | 40 PSI | 60 PSI | 80 PSI | 100 PSI | 150 PSI |
| 742 | 21 | 35 | 48 | 60 | 90 |
| 762 | 35 | 58 | 80 | 100 | 150 |

Dimensions (in.)

| Actuator Size | A | B |
|---------------|------|------|
| 4 | 3.20 | 2.57 |
| 6 | 4.75 | 4.12 |

Capacity per Stroke

| Actuator Model | Cubic Inches |
|----------------|--------------|
| 742 | 1.66 |
| 762 | 2.52 |

Weight

| Actuator Model | Pounds |
|----------------|--------|
| 742 | 0.88 |
| 762 | 1.13 |
| Brackets | 0.30 |

Dimensions (in.)

| Valve Size | C |
|-----------------------|------|
| Apollo 1/4" thru 1/2" | 1.57 |
| Apollo 3/4" | 1.73 |

How To Order: Class-Act (CL) Valve Operator (1/4" – 3/4")

Part Number Example: 742-501-BC-V1-E00

| MODEL | END CAPS | SHAFT | UNIT MATERIAL | VALVE | BRACKET & COUPLING | OPTIONS | OPTIONS |
|-------|----------|-------|---------------|-------|--------------------|---------|---------|
| 742 | 5 | O | 1 | BC | V1 | E00 | XXX |
| 1 | 2 | 3 | 4 | 5 | 6 | 7 | 8 |

1 Model
Operator - Torque (100 psi) - Rotation

| | |
|-----|--------------------|
| 742 | 60 in. lbs. - 90° |
| 762 | 100 in. lbs. - 90° |

2 End Caps

| | |
|---|--------------------------|
| 5 | Pneumatic Clear Anodized |
|---|--------------------------|

3 Shaft

| | |
|---|------------------------|
| O | Double Manual Override |
|---|------------------------|

4 Unit Materials
Shaft - Body - Trim

| | |
|---|--|
| 1 | 303 Stainless Steel, Aluminum, Steel |
| 3 | 303 Stainless Steel, Aluminum, Stainless Steel |

5 Apollo Bronze Ball Valves¹
(Use '00' if not selecting a valve)
Size - Type - Operator

| | |
|----|---------------------|
| 00 | No Valve |
| BA | 1/4" - 2 way - 4 |
| BB | 3/8" - 2 way - 4 |
| BC | 1/2" - 2 way - 4 |
| BD | 3/4" - 2 way - 6 |
| BL | 1/2" - Diverter - 6 |

Apollo Stainless Steel Ball Valves²
Valve Size - Type - Operator Size

| | |
|----|---------------------|
| SA | 1/4" - 2 way - 4 |
| SB | 3/8" - 2 way - 4 |
| SC | 1/2" - 2 way - 4 |
| SD | 3/4" - 2 way - 6 |
| SL | 1/2" - Diverter - 6 |

¹ Bronze 2-way 1/4", 3/8" and 1/2" are Apollo Series 77 Full Port Ball Valve. The 3/4" is Apollo Series 71 Standard Port. Diverter Valves are Series 70. All Bronze valves have Stainless Steel Ball and Stem.

² Stainless Steel 2-way and diverter valves are Apollo Series 76.

6 Bracket
Valve Brand - Valve Size - Material

| | |
|----|---|
| 00 | No Bracket |
| V1 | Apollo - 1/4", 3/8", 1/2" 304 Stainless Steel |
| V2 | Apollo - 3/4", 1" 304 Stainless Steel |

7 Options

| | |
|-----|--|
| 000 | No Options |
| E00 | Factory Assembled Operator Bracket, Coupling and Valve |
| 400 | Adjustable Stroke Control Cap End |
| 704 | Teflon Impregnated Hard Anodized |

8 Switch Options
All Axx Switch Options are Single End Only

| | |
|-----|---|
| A00 | Switch Ready - No Switches |
| A02 | Switch Package ¹ - 2 Reed Switches |
| A05 | Switch Package ² - 2 Sourcing Switches |
| A08 | Switch Package ² - 2 Sinking Switches |

¹ Switch has built in protection for use with ABPLC

² Switch function can be either sinking or sourcing depending on wiring scheme.

Consult Factory for Quick Disconnect Switches

Specifications: Val-U-Act (VA) Valve Operator (1/4" - 3")

Double Acting Valve Operator Systems

- Valve Sizes from 1/4" to 3"
- 140 in. lbs. to 560 in. lbs.

As compared to other rotary devices, ITT Vane Actuators Have:

- One Moving Part Providing:
 - ZERO Backlash
 - No Loss of Motion
 - Smooth Rotation
 - Precise Repeatability
 - Continuous Full Torque Throughout Rotation
- ITT Patented Urethane Seals for:
 - Long Cycle Life and Non-Lube Service

SPECIFICATIONS

Unit Materials

| | |
|-------------------------|------------------------|
| Stator/Rotor Seals..... | Urethane |
| Shaft/Tube Seals | Buna |
| Cylinder | Anodized Alum. |
| End Caps | Anodized Alum. |
| Shaft..... | Mild Steel, Opt'l S.S. |
| Trim | Mild Steel, Opt'l S.S. |
| Bearings | Delrin |
| Brackets..... | Stainless Steel |
| Couplings | Stainless Steel |

Miscellaneous

Inlets.....1/4" NPT

Filtration

Air 25-30 microns

Temperature Range

40°F to 180°F

For applications below 40°F, a variety of seal options are available based upon cycle rates, temperatures and frequency of use. Consult the factory to discuss your cold temperature application for your optimum solution.

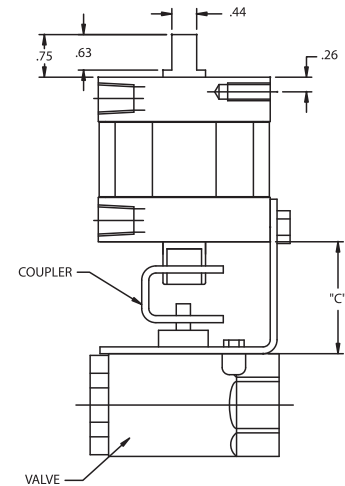
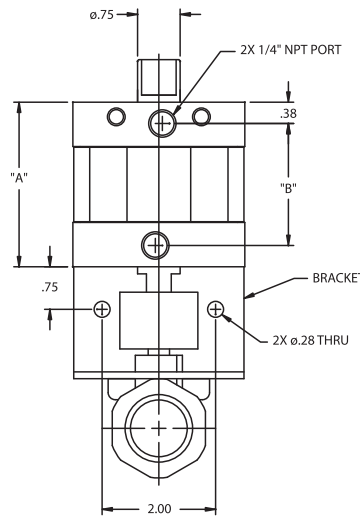
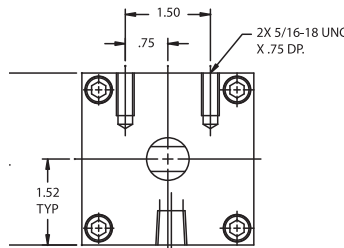

Torque Chart (in.lbs.)

| Actuator Model | Actuator Torque at | | | | |
|----------------|--------------------|--------|--------|---------|---------|
| | 40 PSI | 60 PSI | 80 PSI | 100 PSI | 150 PSI |
| 812 | 70 | 105 | 140 | 175 | 265 |
| 822 | 140 | 210 | 280 | 350 | 524 |
| 832 | 280 | 420 | 560 | 700 | 1050 |

Dimensions (in.)

| Actuator Size | A | B |
|---------------|------|------|
| 1 | 2.90 | 2.15 |
| 2 | 4.40 | 3.64 |
| 3 | 7.42 | 6.67 |

Capacity per Stroke

| Actuator Model | Cubic Inches |
|----------------|--------------|
| 812 | 2.75 |
| 822 | 5.50 |
| 832 | 11.00 |

Weight

| Actuator Model | Pounds |
|----------------|---------|
| 812 | 2.5 |
| 822 | 3.3 |
| 832 | 6.0 |
| Brackets | 0.2-0.8 |

Spring Return

| Actuator Model | Add. Weight |
|----------------|-------------|
| 822 | 3.0 |
| 832 | 9.0 |

Dimensions (in.)

| Valve Size | C |
|-----------------------|------|
| Apollo 1/4" thru 1/2" | 1.69 |
| Apollo 3/4" thru 1" | 1.97 |
| Apollo 1 1/4" thru 2" | 2.31 |
| Apollo 2 1/2" thru 3" | 2.25 |

How To Order: Val-U-Act (VA) Valve Operator (1/4" - 3")

Part Number Example: 812-501-BC-V1-E00

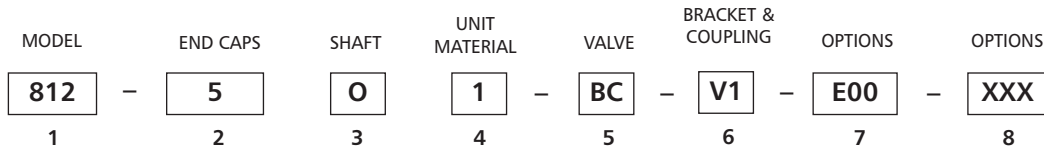

1 Model
Operator - Torque (100 psi) - Rotation

| | |
|-----|--------------------|
| 812 | 175 in. lbs. - 90° |
| 822 | 350 in. lbs. - 90° |
| 832 | 700 in. lbs. - 90° |

2 End Caps

| | |
|---|--------------------------|
| 5 | Pneumatic Clear Anodized |
|---|--------------------------|

3 Shaft

| | |
|---|------------------------|
| O | Double Manual Override |
|---|------------------------|

4 Unit Materials
Shaft - Body - Trim

| | |
|---|---|
| 1 | Polished & Ground Fatigue Proof 1144 Steel - Anod. Alum. - Carb.Steel |
| 3 | 303 Stainless Steel - Anod. Alum. - Stainless Steel |

5 Apollo Bronze Ball Valves¹
(Use '00' if not selecting a valve)
Size - Type - Operator

| | | | |
|----|----------|------------|-----|
| 00 | No Valve | | |
| BA | 1/4" | - 2 way | - 1 |
| BB | 3/8" | - 2 way | - 1 |
| BC | 1/2" | - 2 way | - 1 |
| BD | 3/4" | - 2 way | - 1 |
| BE | 1" | - 2 way | - 1 |
| BF | 1 1/4" | - 2 way | - 2 |
| BG | 1 1/2" | - 2 way | - 2 |
| BH | 2" | - 2 way | - 2 |
| BJ | 3" | - 2 way | - 3 |
| BL | 1/2" | - Diverter | - 1 |
| BM | 3/4" | - Diverter | - 1 |
| BN | 1" | - Diverter | - 1 |
| BO | 1 1/4" | - Diverter | - 2 |
| BP | 1 1/2" | - Diverter | - 2 |
| BQ | 2" | - Diverter | - 2 |

Apollo Stainless Steel Ball Valves²
Valve Size - Type - Operator Size

| | | | |
|----|--------|------------|-----|
| SA | 1/4" | - 2 way | - 1 |
| SB | 3/8" | - 2 way | - 1 |
| SC | 1/2" | - 2 way | - 1 |
| SD | 3/4" | - 2 way | - 1 |
| SE | 1" | - 2 way | - 1 |
| SF | 1 1/4" | - 2 way | - 2 |
| SG | 1 1/2" | - 2 way | - 2 |
| SH | 2" | - 2 way | - 2 |
| SI | 2 1/2" | - 2 way | - 3 |
| SJ | 3" | - 2 way | - 3 |
| SL | 1/2" | - Diverter | - 1 |
| SM | 3/4" | - Diverter | - 1 |
| SN | 1" | - Diverter | - 1 |
| SP | 1 1/2" | - Diverter | - 2 |
| SQ | 2" | - Diverter | - 2 |

¹ Bronze 2-way 1/4", 3/8" and 1/2" are Apollo Series 77 Full Port Ball Valve. 3/4" thru 3" are Apollo Series 71 Standard Port. Diverter Valves are Series 70. All Bronze valves have Stainless Steel Ball and Stem.

² Stainless Steel 2-way and diverter valves are Apollo Series 76.

6 Bracket
Valve Brand - Valve Size - Material

| | |
|----|--|
| 00 | No Bracket |
| V1 | Apollo - 1/4", 3/8", 1/2" 304 Stainless Steel |
| V2 | Apollo - 3/4", 1" 304 Stainless Steel |
| V3 | Apollo - 1 1/4", 1 1/2", 2" 304 Stainless Steel |
| V4 | Apollo - 2 1/2", 3" 304 Stainless Steel |

7 Options

| | |
|-----|--|
| 000 | No Options |
| E00 | Factory Assembled Operator Bracket, Coupling and Valve |
| 400 | Adjustable Stroke Control Cap End |
| 704 | Teflon Impregnated Hardened Anodized |

8 Switch Options
All Axx Switch Options are Single End Only

| | |
|-----|---|
| A00 | Switch Ready - No Switches |
| A02 | Switch Package ¹ - 2 Reed Switches |
| A05 | Switch Package ² - 2 Sourcing Switches |
| A08 | Switch Package ² - 2 Sinking Switches |

¹ Switch has built in protection for use with ABPLC

² Switch function can be either sinking or sourcing depending on wiring scheme.

Consult Factory for Quick Disconnect Switches

How To Order: Val-U-Act Spring Return (VS) (1/4" - 3")

Part Number Example: 822-5A1-BC-V1-E00

| MODEL | END CAPS | SHAFT | UNIT MATERIAL | VALVE | BRACKET & COUPLING | OPTIONS |
|-------|----------|-------|---------------|-------|--------------------|---------|
| 822 | 5 | A | 1 | BC | V1 | E00 |
| 1 | 2 | 3 | 4 | 5 | 6 | 7 |

| 1 Model | |
|--|--------------------|
| Operator - Torque (100 psi) - Rotation | |
| 822 | 350 in. lbs. - 90° |
| 832 | 700 in. lbs. - 90° |

| 2 End Caps | |
|------------|--------------------------|
| 5 | Pneumatic Clear Anodized |

| 3 Shaft | |
|---------|---------------------|
| A | Spring Closes Valve |
| B | Spring Opens Valve |

| 4 Unit Materials | |
|---------------------|---|
| Shaft - Body - Trim | |
| 1 | Polished & Ground Fatigue Proof 1144 Steel - Anod. Alum. - Carb.Steel |
| 3 | 303 Stainless Steel - Anod. Alum. - Stainless Steel |

| 5 Apollo Bronze Ball Valves ¹ | |
|--|--|
| (Use '00' if not selecting a valve) | |
| Size - Type - Operator | |

| | |
|----|-----------------------|
| 00 | No Valve |
| BA | 1/4" - 2 way - 2 |
| BB | 3/8" - 2 way - 2 |
| BC | 1/2" - 2 way - 2 |
| BD | 3/4" - 2 way - 2 |
| BE | 1" - 2 way - 2 |
| BF | 1 1/4" - 2 way - 3 |
| BG | 1 1/2" - 2 way - 3 |
| BH | 2" - 2 way - 3 |
| BL | 1/2" - Diverter - 2 |
| BM | 3/4" - Diverter - 2 |
| BN | 1" - Diverter - 2 |
| BO | 1 1/4" - Diverter - 3 |
| BP | 1 1/2" - Diverter - 3 |
| BQ | 2" - Diverter - 3 |

| Apollo Stainless Steel Ball Valves ² | |
|---|--|
| Valve Size - Type - Operator Size | |

| | |
|----|-----------------------|
| SA | 1/4" - 2 way - 2 |
| SB | 3/8" - 2 way - 2 |
| SC | 1/2" - 2 way - 2 |
| SD | 3/4" - 2 way - 2 |
| SE | 1" - 2 way - 2 |
| SF | 1 1/4" - 2 way - 3 |
| SG | 1 1/2" - 2 way - 3 |
| SH | 2" - 2 way - 3 |
| SL | 1/2" - Diverter - 2 |
| SM | 3/4" - Diverter - 2 |
| SN | 1" - Diverter - 2 |
| SP | 1 1/2" - Diverter - 3 |
| SQ | 2" - Diverter - 3 |

1 Bronze 2-way 1/4", 3/8" and 1/2" are Apollo Series 77 Full Port Ball Valve. 3/4" thru 3" are Apollo Series 71 Standard Port. Diverter Valves are Series 70. All Bronze valves have Stainless Steel Ball and Stem.

2 Stainless Steel 2-way and diverter valves are Apollo Series 76.

| 6 Bracket | |
|-------------------------------------|--|
| Valve Brand - Valve Size - Material | |

| | |
|----|--|
| 00 | No Bracket |
| V1 | Apollo - 1/4", 3/8", 1/2" 304 Stainless Steel |
| V2 | Apollo - 3/4", 1" 304 Stainless Steel |
| V3 | Apollo - 1 1/4", 1 1/2", 2" 304 Stainless Steel |
| V4 | Apollo - 2 1/2", 3" 304 Stainless Steel |

| 7 Options | |
|-----------|--|
| 000 | No Options |
| E00 | Factory Assembled Operator Bracket, Coupling and Valve |
| 400 | Adjustable Stroke Control Cap End, Pos. 5 |
| 704 | Teflon Impregnated Hard Anodized Note: Operator Only |

Spring Return

Description:

Spring Return operators are formed bolting a spring return unit to a double acting Val-U-Act operator. The return movement is effected by a clock-type spring which is pretensioned to about half the operator torque. The amount of pretension is large, compared to the rotation and therefore the torque does not vary more than 20% over the rotation.

Spring returns are factory-installed and adjusted.

Specifications:

Spring Casing - pressure diecast to BS1004 zinc or aluminum alloy LM25

Finish - Epoxy stove enamel

Spring - Clock type, spring steel

Ordering:

The spring return is available with the optional Adjustable Stroke Control but not with the Hall Effect or AC/DC Reed Switches.

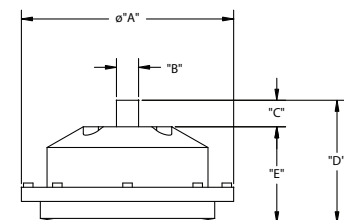
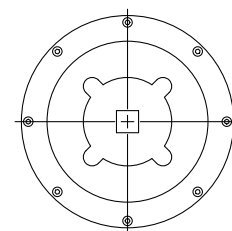

| Dimensions (in.) | | | | | |
|------------------|------|------|------|------|------|
| Operator Size | A | B | C | D | E |
| 2 | 4.22 | .375 | .500 | 2.25 | 1.78 |
| 3 & 4 | 5.97 | .625 | .750 | 4.06 | 3.23 |

Warranty Statement

Warranty

Seller warrants for one year from the date of shipment Seller's manufactured products to the extent that Seller will replace those having defects in material or workmanship when used for the purpose and in the manner which Seller recommends. If Seller's examination shall disclose to its satisfaction that the products are defective, and an adjustment is required, the amount of such adjustment shall not exceed the net sales price of the defective products only and no allowance will be made for labor or expense of repairing or replacing defective products or workmanship or damage resulting from the same. Seller warrants the products which it sells of other manufacturers to the extent of the warranties of their respective makers. Where engineering design or fabrication work is supplied, Buyer's acceptance of Seller's design or of delivery of work shall relieve Seller of all further obligation, other than as expressed in Seller's product warranty. THIS IS SELLER'S SOLE WARRANTY. SELLER MAKES NO OTHER WARRANTY OF ANY KIND, EXPRESSED OR IMPLIED. AND ALL IMPLIED WARRANTIES OF MERCHANTABILITY AND FITNESS FOR A PARTICULAR PURPOSE WHICH EXCEED SELLER'S AFORESTATED OBLIGATION ARE HEREBY DISCLAIMED BY SELLER AND EXCLUDED FROM THIS WARRANTY. Seller neither assumes, nor authorizes any person to assume for it, any other obligation in connection with the sale of its engineering designs or products. This warranty shall not apply to any products or parts of products which (a) have been repaired or altered outside of Seller's factory, in any manner; or (b) have been subjected to misuse, negligence or accidents; or (c) have been used in a manner contrary to Seller's instructions or recommendations. Seller shall not be responsible for design errors due to inaccurate or incomplete information supplied by Buyer or its representatives.

SELLER'S LIABILITY: Seller will not be liable for any loss, damage, cost of repairs, incidental or consequential damages of any kind, whether based upon warranty (except for the obligation accepted by Seller under "Warranty" above), contract or negligence, arising in connection with the design, manufacture, sale, use or repair of the products or of the engineering designs supplied to Buyer.

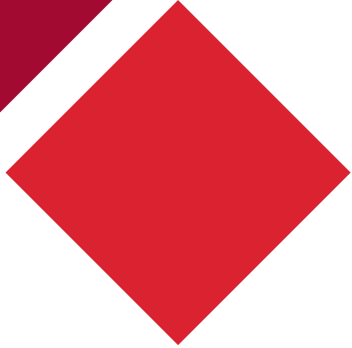
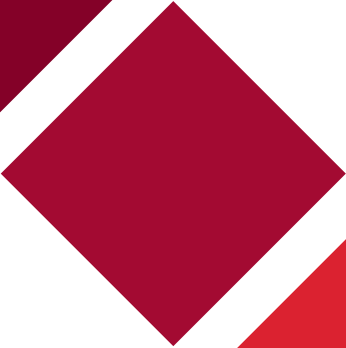

COMPACT[®]
AUTOMATION PRODUCTS

Compact Automation Products, LLC
105 Commerce Way
Westminster, SC 29693
Tel: 864.647.9521
Fax: 864.647.9574
www.compactautomation.com

TA871R4

An ITT Company

07/21