

# Distribution & Control Transformers and Power Supplies

## Contents

<i>Description</i>	<i>Page</i>
<b>Distribution Transformers</b>	
Single-Phase Encapsulated and Ventilated, 60 Hz. ....	44-2
Electrostatically Shielded Transformers. ....	44-8
Open Type Core and Coil Assembly Transformers. ....	44-13
Buck-Boost and Low Voltage Lighting Transformers. ....	44-15
<b>Control Transformers</b>	
Type MTA. ....	44-32
Type MTC. ....	44-37
Type MTE. ....	44-39
Type MTK. ....	44-48
CE Marked. ....	44-53
Type AP. ....	44-61
<b>Product Selection</b> .....	<b>44-63</b>
<b>Power Supplies</b> .....	<b>44-65</b>
PSG. ....	44-65
PSS. ....	44-71
ELC. ....	44-77
EZ. ....	44-79
Sensor Power Supply. ....	44-81



*Control Transformers*

*PSG Power Supplies*

Single-Phase Encapsulated (Type EP), Ventilated (Type DS-3), 60 Hz

## Single-Phase Encapsulated (Type EP), Ventilated (Type DS-3), 60 Hz



Type EP 3-25 kVA

### Product Description

#### Type EP

- Sand and Resin Encapsulated design.
- Suitable for indoor or outdoor applications.
- Totally enclosed, non-ventilated enclosures.
- Enclosures are NEMA® 3R rated.
- Mountable in any position indoors and upright only outdoors.
- 185°C insulation system.
- 115°C rise standard; 80°C optional.
- Available in ratings through 37.5 kVA and 4160 volts primary.

#### Type DS-3

- Ventilated, NEMA 2 enclosure standard.
- Suitable for indoor applications, outdoors when weathershields are also installed.
- Upright mounting only.
- 220°C insulation system.
- 150°C rise standard; 115°C or 80°C optional.
- Available in single-phase ratings 15 – 167 kVA and up to 4160 volts primary.

### Application Description

The basic purpose of a transformer is voltage transformation as near as practically possible to the load for economy and distribution of power. Typical loads for dry-type distribution transformers include lighting, heating, air conditioners, fans and machine tools. Such loads are found in commercial, institutional, industrial and residential structures.

### Features, Benefits and Functions

- UL® listed.
- 60 Hz operation.
- Short-term overload capability as required by ANSI.
- Meet NEMA ST-20 sound levels.

### Standards and Certifications

#### Industry Standards

All Cutler-Hammer® dry-type distribution and control transformers by Eaton Corporation are built and tested in accordance with applicable NEMA, ANSI and IEEE Standards. All 600 volt class transformers are UL listed unless otherwise noted.

#### Seismically Qualified

Cutler-Hammer manufactured dry-type distribution transformers are seismically qualified, and exceed requirements of the Uniform Building Code® (UBC), International Building Code (IBC), and California Code Title 24.

### Product Specifications

#### Frequency

Cutler-Hammer standard dry-type distribution transformers are designed for 60 Hertz operation. Transformers required for other frequencies are available and must be specifically designed.

#### Overload Capability

Short-term overload is designed into transformers as required by ANSI. Dry-type distribution transformers will deliver 200% nameplate load for one-half hour; 150% load for one hour; and 125% load for four hours without being damaged provided that a constant 50% load precedes and follows the overload. See ANSI C57.96-01.250 for additional limitations.

Continuous overload capacity is not deliberately designed into a transformer because the design objective is to be within the allowed winding temperature rise with nameplate loading.

#### Insulation System and Temperature Rise

Industry standards classify insulation systems and rise as shown below:

Table 44-1. Insulation System Classification

Ambient	+ Winding Rise	+ Hot Spot	= Temp. Class
40°C	55°C	10°C	105°C
40°C	80°C	30°C	150°C
40°C	115°C	30°C	185°C
40°C	150°C	30°C	220°C

The design life of transformers having different insulation systems is the same — the lower temperature systems are designed for the same life as the higher temperature systems.

#### Enclosures

Cutler-Hammer ventilated transformers, Type DS-3, utilize a NEMA 2 rated (drip-proof) enclosure as standard, and are rated NEMA 3R with the addition of weathershields. Cutler-Hammer encapsulated transformers, Type EP, utilize a NEMA 3R rated enclosure as standard.

#### Sound Levels

All Cutler-Hammer 600 volt class general purpose dry-type distribution transformers are designed to meet NEMA ST-20 sound levels listed here. These are the sound levels measured in a soundproof environment. Actual sound levels measured at an installation will likely be higher due to electrical connections and environmental conditions. Lower sound levels are available and should be specified when the transformer is going to be installed in an area where sound may be a concern.

Table 44-2. Average Sound Levels ①

NEMA ST-20 Average Sound Level in dB			
kVA	Up to 1.2 kV		Above 1.2 kV
	Ventilated	Encapsulated	Ventilated
0 – 9	40	45	45
10 – 50	45	50	50
51 – 150	50	55	55
151 – 300	55	57	58
301 – 500	60	59	60
501 – 700	62	61	62
701 – 1000	64	63	64
1001 – 1500	65	64	65

① Currently being reviewed and revised by NEMA.

**Winding Terminations**

Primary and secondary windings are terminated in the wiring compartment. Encapsulated units have copper leads or stabs brought out for connections. Ventilated transformers have leads brought out to aluminum pads that are pre-drilled to accept Cu/Al lugs. **Lugs are not supplied with these transformers.** Eaton recommends external cables be rated 90°C (sized at 75°C ampacity) for encapsulated designs and 75°C for ventilated designs.

**Series-Multiple Windings**

Series-multiple windings consist of two similar coils in each winding which can be connected in series or parallel (multiple). Transformers with series-multiple windings are designated with an "X" or "/" between the voltage ratings, such as voltages of "120/240" or "240 X 480." If the series-multiple winding is designated by an "X," the winding can be connected only for a series or parallel. With the "/" designation, a mid-point also becomes available in addition to the series or parallel connection. As an example, a 120 X 240 winding can be connected for either 120 (parallel) or 240 (series), but a 120/240 winding can be connected for 120 (parallel), or 240 (series), or 240 with a 120 mid-point.

The following pages provide listings for most standard transformer ratings and styles.

For other ratings or styles not shown, or for special enclosure types (including stainless steel), refer to Eaton.

Single-Phase Encapsulated (Type EP), Ventilated (Type DS-3), 60 Hz

Product Selection

Additional Product Selection information begins on Page 44-63.



Type EP 3-37.5 kVA



Type DS-3 15-167 kVA

Table 44-3. Single-Phase Selection Information — Types EP, DS-3, 60 Hz

kVA	Full Cap. Taps		Type	°C Temp. Rise	Dimensions (Inches)			Wt. Lbs.	Dimensions (mm)			Wt. kg	Frame	Wiring Diagram Number	Weathershield		Style Number	Price U.S. \$
	FCAN	FCBN			H	W	D		H	W	D				Catalog Number	Price U.S. \$		
<b>120 x 240 Volts to 120/240 Volts ①</b>																		
.5	—	—	EP	115	6-1/2	4-5/8	4-15/16	16	165	117	125	7	FR57	3E	Indoor- Outdoor		S10N11S51N	
1	—	—	EP	115	8-5/8	5-3/4	5-3/4	31	219	146	146	14	FR59A	3E			S10N11S01N	
1.5	—	—	EP	115	10-3/4	6-3/16	6-5/8	42	273	157	166	19	FR67	3E			S10N11S16N	
2	—	—	EP	115	10-3/4	6-3/16	6-5/8	42	273	157	166	19	FR68	3E	Indoor- Outdoor		S10N11S02N	
3	—	—	EP	115	14-1/8	7-3/4	8	55	359	197	203	25	FR176	3E			S10N11S03N	
5	—	—	EP	115	16	10-3/8	9-7/8	113	406	263	251	51	FR177	3E			S10N11S05N	
7.5	—	—	EP	115	16	10-3/8	9-7/8	123	406	263	251	56	FR178	3E	Indoor- Outdoor		S10N11S07N	
10	—	—	EP	115	19	13-3/8	10-1/2	193	482	339	266	88	FR179	3E			S10N11S10N	
15	—	—	EP	115	19	13-3/8	13-3/8	216	482	339	266	98	FR180	3E			S10N11S15N	
25	—	—	EP	115	22-3/8	16-3/8	14-1/2	375	568	416	368	170	FR182	3E			S10N11S25N	
37.5	②	②	DS-3	150	37-5/8	22-5/8	19-1/2	306	953	574	495	139	FR817	3XD	WS11		T10P11S37	
50	②	②	DS-3	150	37-5/8	22-5/8	19-1/2	340	956	574	495	154	FR818	3XD			WS11	T10P11S50
<b>208 Volts to 120/240 Volts ①</b>																		
.5	—	—	EP	115	6-1/2	4-5/8	4-15/16	16	165	117	125	7	FR57	26A	Indoor- Outdoor		S29N11S51N	
1	—	—	EP	115	8-5/8	5-3/4	5-3/4	31	219	146	146	14	FR59A	26A			S29N11S01N	
1.5	—	—	EP	115	10-3/4	6-3/16	6-5/8	42	273	157	166	19	FR67	26A			S29N11S16N	
2	—	—	EP	115	10-3/4	6-3/16	6-5/8	42	273	157	166	19	FR68	26A	Indoor- Outdoor		S29N11S02N	
3	—	—	EP	115	14-1/8	7-3/4	8	65	359	197	203	30	FR176	26A			S29N11S03N	
5	—	—	EP	115	16	10-3/8	9-7/8	113	406	263	251	51	FR177	26A			S29N11S05N	
7.5	—	—	EP	115	16	10-3/8	9-7/8	123	406	263	251	56	FR178	26A	Indoor- Outdoor		S29N11S07N	
10	—	—	EP	115	19	13-3/8	10-1/2	193	482	339	266	88	FR179	26A			S29N11S10N	
15	—	—	EP	115	19	13-3/8	13-3/8	216	482	339	266	98	FR180	26A			S29N11S15N	
25	—	—	EP	115	22-3/8	16-3/8	14-1/2	395	568	416	359	179	FR182	26A			S29N11S25N	
25	2@+2.5%	4@-2.5%	DS-3	150	31-1/4	22-5/8	17-1/2	212	793	574	445	96	FR816	260A	WS11		T29M11S25	
37.5	2@+2.5%	4@-2.5%	DS-3	150	37-5/8	22-5/8	19-1/2	306	953	574	495	139	FR817	260A			WS11	T29M11S37
50	2@+2.5%	4@-2.5%	DS-3	150	37-5/8	22-5/8	19-1/2	340	956	574	495	154	FR818	260A	WS11	T29M11S50		
75	2@+2.5%	4@-2.5%	DS-3	150	42-1/8	24	23-3/8	510	1070	610	594	232	FR819	260A	WS16		T29M11S75	
100	1@+5%	2@-5%	DS-3	150	42-1/8	24	23-3/8	600	1070	610	594	272	FR820	551A			WS16	T29R11S99
<b>277 Volts to 120/240 Volts ①</b>																		
.5	—	—	EP	115	8-5/8	5-3/4	5-3/4	26	165	146	146	12	FR58A	524A	Indoor- Outdoor		S27N11S51A	
1	—	—	EP	115	8-5/8	5-3/4	5-3/4	31	219	146	146	14	FR59A	524A			S27N11S01A	
1.5	—	—	EP	115	10-3/4	6-3/16	6-5/8	42	273	157	166	19	FR67	524A			S27N11S16A	
2	—	—	EP	115	10-3/4	7-3/4	8	65	359	197	203	30	FR176	524A	Indoor- Outdoor		S27N11S02A	
3	—	—	EP	115	14-1/8	7-3/4	8	55	359	197	203	25	FR176	524A			S27N11S03N	
5	—	—	EP	115	16	10-3/8	9-7/8	113	406	263	251	51	FR177	524A			S27N11S05N	
7.5	—	—	EP	115	16	10-3/8	9-7/8	123	406	263	251	56	FR178	524A	Indoor- Outdoor		S27N11S07N	
10	—	—	EP	115	19	13-3/8	10-1/2	193	482	339	266	88	FR179	524A			S27N11S10N	
15	—	—	EP	115	19	13-3/8	13-3/8	180	482	339	266	82	FR180	524A			S27N11S15N	
25	—	—	EP	115	22-3/8	16-3/8	14-1/2	375	568	416	359	170	FR182	524A			S27N11S25N	
25	2@+2.5%	4@-2.5%	DS-3	150	31-1/4	22-5/8	17-1/2	212	793	574	445	96	FR816	262C	WS11		T27M11S25	
37.5	2@+2.5%	4@-2.5%	DS-3	150	37-5/8	22-5/8	19-1/2	306	953	574	495	139	FR817	262C			WS11	T27M11S37
50	2@+2.5%	4@-2.5%	DS-3	150	37-5/8	22-5/8	19-1/2	340	956	574	495	154	FR818	262C	WS11	T27M11S50		
75	2@+2.5%	4@-2.5%	DS-3	150	42-1/8	24	23-3/8	510	1070	610	594	232	FR819	262C	WS16		T27M11S75	
100	2@+2.5%	4@-2.5%	DS-3	150	42-1/8	24	23-3/8	600	1070	610	594	272	FR820	262C			WS16	T27M11S99

① Contact Eaton for availability of 0.05 – 0.25 kVA designs.

② 1@+5%, 2@-5% at 240 volts primary; 2@+2.5%, 4@-2.5% at 480 volts primary.

Note: Contact your local Eaton sales office for CE Mark transformer requirements.

Discount Symbol ..... DT-1

**Table 44-4. Single-Phase Selection Information — Types EP, DS-3, 60 Hz**

kVA	Full Cap. Taps		Type	°C Temp. Rise	Dimensions (Inches)			Wt. Lbs.	Dimensions (mm)			Wt. kg	Frame	Wiring Diagram Number	Weathershield		Style Number	Price U.S. \$
	FCAN	FCBN			H	W	D		H	W	D				Catalog Number	Price U.S. \$		
<b>240 x 480 Volts to 120/240 Volts</b>																		
.050	—	—	EP	115	6-1/2	3-7/8	3-7/8	7	165	98	98	3	FR52	3A	Indoor- Outdoor		S20N11S81N	
.075	—	—	EP	115	6-1/2	3-7/8	3-7/8	7	165	98	98	3	FR54	3A			S20N11S85N	
.100	—	—	EP	115	6-1/2	3-7/8	3-7/8	7	165	98	98	3	FR54	3A			S20N11S82N	
.150	—	—	EP	115	6-1/2	3-7/8	3-7/8	8	165	98	98	4	FR55	3A	Indoor- Outdoor		S20N11S83N	
.25	—	—	EP	115	6-1/2	4-5/8	4-1/8	12	165	117	103	5	FR56	3A			S20N11S26N	
.5	—	—	EP	115	6-1/2	4-5/8	4-15/16	16	165	117	125	7	FR57	3A			S20N11S51N	
.75	—	—	EP	115	8-5/8	5-3/4	5-3/4	26	219	146	146	12	FR58A	3A	Indoor- Outdoor		S20N11S76N	
1	—	—	EP	115	8-5/8	5-3/4	5-3/4	31	219	146	146	14	FR59A	3A			S20N11S01N	
1.5	—	—	EP	115	10-3/4	6-3/16	6-5/8	42	273	157	166	19	FR67	3A			S20N11S16N	
2	—	—	EP	115	10-3/4	6-3/16	6-5/8	42	273	157	166	19	FR68	3A	Indoor- Outdoor		S20N11S02N	
3	—	—	EP	115	14-1/8	7-3/4	8	65	359	197	203	30	FR176	3A			S20N11S03N	
3	①	①	EP	115	14-1/8	7-3/4	8	65	359	197	203	30	FR176	9A			S20K11S03N	
5	—	—	EP	115	16	10-3/8	9-7/8	113	406	263	251	51	FR177	3A	Indoor- Outdoor		S20N11S05N	
5	①	①	EP	115	16	10-3/8	9-7/8	105	406	263	251	48	FR177	9A			S20K11S05N	
7.5	—	—	EP	115	16	10-3/8	9-7/8	105	406	263	251	48	FR178	3A			S20N11S07N	
7.5	①	①	EP	115	16	10-3/8	9-7/8	123	406	263	251	56	FR178	9A	Indoor- Outdoor		S20K11S07N	
10	—	—	EP	115	19	13-3/8	10-1/2	193	482	339	266	88	FR179	3A			S20N11S10N	
10	①	①	EP	115	19	13-3/8	10-1/2	193	482	339	266	88	FR179	9A			S20K11S10N	
15	—	—	EP	115	19	13-3/8	13-3/8	216	482	339	266	98	FR180	3A	Indoor- Outdoor		S20N11S15N	
15	②	②	EP	115	19	13-3/8	13-3/8	216	482	339	266	98	FR180	23A			S20L11S15N	
25	—	—	EP	115	22-3/8	16-3/8	14-1/2	385	568	416	368	175	FR182	3A			S20N11S25N	
25	②	②	EP	115	22-3/8	16-3/8	14-1/2	375	568	416	368	170	FR182	23A	Indoor- Outdoor		S20L11S25N	
37.5	②	②	EP	115	28-1/4	22-5/8	14-5/8	735	717	570	371	334	FR300A	248A			S20L11S37 <sup>④</sup>	
15	③	③	DS-3	150	30-1/4	16-7/8	15-7/8	147	768	428	402	67	FR815	3XA	WS15 WS11 WS11		T20P11S15	
25	③	③	DS-3	150	31-1/4	22-5/8	17-1/2	212	793	574	445	96	FR816	3XA			T20P11S25	
37.5	③	③	DS-3	150	37-5/8	22-5/8	19-1/2	306	953	574	495	139	FR817	3XA			T20P11S37	
50	③	③	DS-3	150	37-5/8	22-5/8	19-1/2	340	956	574	495	154	FR818	3XA	WS11 WS16 WS16 WS13		T20P11S50	
75	③	③	DS-3	150	42-1/8	24	23-3/8	510	1070	610	594	232	FR819	3XA			T20P11S75	
100	③	③	DS-3	150	42-1/8	24	23-3/8	600	1070	610	594	272	FR820	3XA			T20P11S99	
167	2@+2.5%	4@-2.5%	DS-3	150	62-7/8	30	34	1200	1597	762	863	545	FR814	288A		T48M11S67D <sup>⑤</sup>		

- ① 1@+10% FCAN at 240 volts; 2@+5% FCAN at 480 volts.
- ② 2@+5% FCAN at 240 volts; 4@+2.5% FCAN at 480 volts.
- ③ 1@+5%, 2@-5% at 240 volts primary; 2@+2.5%, 4@-2.5% at 480 volts primary.
- ④ Floor-mount only.
- ⑤ 480 volts primary to 120/240 volts secondary.

**Note:** Contact your local Eaton sales office for CE Mark transformer requirements.

For other ratings or styles not shown, or for special enclosure types (including stainless steel), refer to Eaton.

Discount Symbol ..... DT-1

Single-Phase Encapsulated (Type EP), Ventilated (Type DS-3), 60 Hz

Table 44-5. Single-Phase Selection Information — Types EP, DS-3, 60 Hz

kVA	Full Cap. Taps		Type	°C Temp. Rise	Dimensions (Inches)			Wt. Lbs.	Dimensions (mm)			Wt. kg	Frame	Wiring Diagram Number	Weathershield		Style Number	Price U.S. \$
	FCAN	FCBN			H	W	D		H	W	D				Catalog Number	Price U.S. \$		
<b>190/200/208/220 x 380/400/416/440 Volts to 110/220 Volts 50/60 Hz — Export Model IP 22 Rated</b>																		
.5	—	—	EP	115	10-3/4	6-3/16	6-5/8	42	273	157	166	19	FR67	538A	Indoor- Outdoor		S40N14S51CE	
1	—	—	EP	115	10-3/4	6-3/16	6-5/8	42	273	157	166	19	FR67	538A			S40N14S01CE	
1.5	—	—	EP	115	14-1/8	7-3/4	8	65	359	197	203	30	FR176	538A			S40N14S16CE	
2	—	—	EP	115	14-1/8	7-3/4	8	65	359	197	203	30	FR176	538A			S40N14S02CE	
3	—	—	EP	115	16	10-3/8	9-7/8	113	406	263	251	51	FR177	538A	Indoor- Outdoor		S40N14S03CE	
5	—	—	EP	115	16	10-3/8	9-7/8	140	406	263	251	64	FR178	538A			S40N14S05CE	
7.5	—	—	EP	115	19	13-3/8	10-1/2	193	482	339	266	88	FR179	538A			S40N14S07CE	
10	—	—	EP	115	19	13-3/8	13-3/8	216	482	339	266	98	FR180	538A	Indoor- Outdoor		S40N14S10CE	
15	—	—	EP	115	22-3/8	16-3/8	14-1/2	375	433	415	359	170	FR182	538A			S40N14S15CE	
<b>120/208/240/277 Volts to 120/240 Volts 60 Hz</b>																		
1	—	—	EP	115	10-3/4	6-3/16	6-5/8	42	273	157	166	19	FR67	②	Indoor- Outdoor		S54N11S01	
1.5	—	—	EP	115	14-1/8	7-3/4	8	65	359	197	203	30	FR176	②			S54N11S16	
2	—	—	EP	115	14-1/8	7-3/4	8	65	359	197	203	30	FR176	②			S54N11S02	
3	—	—	EP	115	16	10-3/8	9-7/8	113	406	263	251	51	FR177	②	Indoor- Outdoor		S54N11S03	
5	—	—	EP	115	16	10-3/8	9-7/8	140	406	263	251	64	FR178	②			S54N11S05	
7.5	—	—	EP	115	19	13-3/8	10-1/2	193	482	339	266	88	FR179	②			S54N11S07	
10	—	—	EP	115	19	13-3/8	13-3/8	216	482	339	266	98	FR180	②			S54N11S10	
<b>240 x 480 Volts to 120/240 Volts Stainless Steel ①</b>																		
3	—	—	EP	115	14-1/8	7-3/4	8	65	359	197	203	30	FR176	3A	Indoor- Outdoor		S20N11S03SS	
5	—	—	EP	115	16	10-3/8	9-7/8	113	406	263	251	51	FR177	3A			S20N11S05SS	
7.5	—	—	EP	115	16	10-3/8	9-7/8	123	406	263	251	56	FR178	3A			S20N11S07SS	
10	—	—	EP	115	19	13-3/8	10-1/2	193	482	339	266	88	FR179	3A	Indoor- Outdoor		S20N11S10SS	
15	—	—	EP	115	19	13-3/8	13-3/8	205	482	339	266	93	FR180	3A			S20N11S15SS	
25	—	—	EP	115	22-3/8	16-3/8	14-1/2	375	566	416	359	170	FR182	3A			S20N11S25SS	
<b>480 Volts to 120/240 Volts</b>																		
1	—	2@-5%	EP	115	8-5/8	5-3/4	5-3/4	31	219	146	146	14	FR59A	2D	Indoor- Outdoor		S48G11S01N	
1.5	—	2@-5%	EP	115	10-3/4	6-3/16	6-5/8	42	273	157	166	19	FR67	2D			S48G11S16N	
2	—	2@-5%	EP	115	10-3/4	6-3/16	6-5/8	42	273	157	166	19	FR68	2D			S48G11S02N	
3	—	2@-5%	EP	115	14-1/8	7-3/4	8	65	359	197	203	30	FR176	2D	Indoor- Outdoor		S48G11S03N	
3	2@+2.5%	2@+2.5%	EP	115	14-1/8	7-3/4	8	65	359	197	203	30	FR176	16A			S48D11S03N	
5	—	2@-5%	EP	115	16	10-3/8	9-7/8	113	406	263	251	51	FR177	2D			S48G11S05N	
5	2@+2.5%	2@+2.5%	EP	115	16	10-3/8	9-7/8	113	406	263	251	51	FR177	16A	Indoor- Outdoor		S48D11S05N	
7.5	—	2@-5%	EP	115	16	10-3/8	9-7/8	123	406	263	251	56	FR178	2D			S48G11S07N	
7.5	2@+2.5%	2@+2.5%	EP	115	16	10-3/8	9-7/8	123	406	263	251	56	FR178	16A			S48D11S07N	
10	—	2@-5%	EP	115	19	13-3/8	10-1/2	193	482	339	266	88	FR179	2D	Indoor- Outdoor		S48G11S10N	
10	2@+2.5%	2@+2.5%	EP	115	19	13-3/8	10-1/2	193	482	339	266	88	FR179	16A			S48D11S10N	
15	—	2@-5%	EP	115	19	13-3/8	13-3/8	216	482	339	266	98	FR180	2D			S48G11S15N	
15	2@+2.5%	2@+2.5%	EP	115	19	13-3/8	13-3/8	216	482	339	266	98	FR180	16A	Indoor- Outdoor		S48D11S15N	
25	—	2@-5%	EP	115	22-3/8	16-3/8	14-1/2	385	568	416	359	175	FR182	2D			S48G11S25N	
25	2@+2.5%	4@-2.5%	EP	115	20-3/4	19-1/8	13-5/8	410	525	483	349	186	FR132	83A			S48M11S25N	
<b>480 Volts to 120/240 Volts Stainless Steel, Copper Windings ①</b>																		
10	2@+2.5%	2@+2.5%	EP	115	19	13-3/8	10-1/2	210	482	339	266	95	FR179	16A	Indoor- Outdoor		S48D11S10SSCU	
15	2@+2.5%	2@+2.5%	EP	115	19	13-3/8	13-3/8	235	482	339	266	107	FR180	16A			S48D11S15SSCU	
25	2@+2.5%	4@-2.5%	EP	115	22-3/8	16-3/8	14-1/2	415	525	483	349	188	FR182	83A			S48M11S25SSCU	
<b>600 Volts to 120/240 Volts</b>																		
.5	—	2@-5%	EP	115	6-1/2	4-5/8	4-15/16	16	165	117	125	7	FR57	2I	Indoor- Outdoor		S60G11S51N	
.75	—	2@-5%	EP	115	8-5/8	5-3/4	5-3/4	26	219	146	146	12	FR58A	2I			S60G11S76N	
1	—	2@-5%	EP	115	8-5/8	5-3/4	5-3/4	31	219	146	146	14	FR59A	2I			S60G11S01N	
1.5	—	2@-5%	EP	115	10-3/4	6-3/16	6-5/8	42	273	157	166	19	FR67	2I	Indoor- Outdoor		S60G11S16N	
2	—	2@-5%	EP	115	10-3/4	6-3/16	6-5/8	42	273	157	166	19	FR68	2I			S60G11S02N	
3	—	2@-5%	EP	115	14-1/8	7-3/4	8	65	359	197	203	30	FR176	2I			S60G11S03N	
5	—	2@-5%	EP	115	16	10-3/8	9-7/8	105	406	263	251	48	FR177	2I	Indoor- Outdoor		S60G11S05N	
7.5	—	2@-5%	EP	115	16	10-3/8	9-7/8	123	406	263	251	56	FR178	2I			S60G11S07N	
10	—	2@-5%	EP	115	19	13-3/8	10-1/2	193	482	339	266	88	FR179	2I			S60G11S10N	
15	—	4@-2.5%	EP	115	19	13-3/8	13-3/8	216	482	339	266	98	FR180	527A	Indoor- Outdoor		S60J11S15N	
25	—	4@-2.5%	EP	115	22-3/8	16-3/8	14-1/2	385	568	416	359	175	FR182	527A			S60J11S25N	
25	2@+2.5%	4@-2.5%	EP	115	20-3/4	19-1/8	13-5/8	395	525	483	349	180	FR132	83B			S60M11S25N	
25	2@+2.5%	4@-2.5%	DS-3	150	31-1/4	22-5/8	17-1/2	212	793	574	445	96	FR816	276B	WS11		T60M11S25	
37.5	2@+2.5%	4@-2.5%	DS-3	150	37-5/8	22-5/8	19-1/2	306	953	574	495	139	FR817	262B	WS11		T60M11S37	
50	2@+2.5%	4@-2.5%	DS-3	150	37-5/8	22-5/8	19-1/2	340	956	574	495	154	FR818	262B	WS11		T60M11S50D	
75	2@+2.5%	4@-2.5%	DS-3	150	42-1/8	24	23-3/8	510	1070	610	594	232	FR819	262B	WS16		T60M11S75	
100	2@+2.5%	4@-2.5%	DS-3	150	42-1/8	24	23-3/8	600	1070	610	594	272	FR820	262B	WS16		T60M11S99	
167	2@+2.5%	4@-2.5%	DS-3	150	62-7/8	30	34	1200	1597	762	863	545	FR814	288B	WS13		T60M11S67A	

① NEMA 3R, 316 stainless steel enclosure.

② Refer to your local Eaton sales office

**Note:** Contact your local Eaton sales office for CE Mark transformer requirements.

For other ratings or styles not shown, or for special enclosure types (including stainless steel), refer to Eaton.

Discount Symbol ..... DT-1

**Single-Phase Encapsulated (Type EP), Ventilated (Type DS-3), 60 Hz**

**Table 44-6. Single-Phase Selection Information — Types EP, DS-3, 60 Hz**

kVA	Full Cap. Taps		Type	°C Temp. Rise	Dimensions (Inches)			Wt. Lbs.	Dimensions (mm)			Wt. kg	Frame	Wiring Diagram Number	Weathershield		Style Number	Price U.S. \$
	FCAN	FCBN			H	W	D		H	W	D				Catalog Number	Price U.S. \$		
<b>2400 Volts to 120/240 Volts</b>																		
1.5	—	—	EP	115	10-3/4	6-3/16	6-5/8	42	273	157	166	19	FR68	18A	—	—	S42N11S16N <sup>①</sup>	
3	—	4@-2.5%	EP	115	16	10-3/8	9-7/8	113	406	263	251	51	FR177	12A	—	—	S42J11S03N <sup>①</sup>	
5	—	4@-2.5%	EP	115	16	10-3/8	9-7/8	123	406	263	251	56	FR178	12A	—	—	S42J11S05N <sup>①</sup>	
10	—	4@-2.5%	EP	115	19	13-3/8	10-1/2	216	482	339	266	98	FR179	12A	—	—	S42J11S10N <sup>①</sup>	
15	—	4@-2.5%	EP	115	22-3/8	16-3/8	14-1/2	375	566	416	359	170	FR182	12A	—	—	S42J11S15N <sup>①</sup>	
25	—	4@-2.5%	EP	115	26-3/8	16-3/8	14-1/8	405	668	416	359	184	FR190	12A	—	—	S42J11S25N <sup>①</sup>	
37.5	2@+2.5%	2@-2.5%	DS-3	150	28	22	20	300	684	537	488	137	②	②	—	—	T42D11S37 <sup>③④</sup>	
50	2@+2.5%	2@-2.5%	DS-3	150	30	24	26	420	732	586	635	191	②	②	—	—	T42D11S50 <sup>③④</sup>	
75	2@+2.5%	2@-2.5%	DS-3	150	30	24	26	500	732	586	635	228	②	②	—	—	T42D11S75 <sup>③④</sup>	
100	2@+2.5%	2@-2.5%	DS-3	150	36	27	26	570	879	659	635	260	②	②	—	—	T42D11S99 <sup>③④</sup>	
<b>2400 Volts to 240/480 Volts</b>																		
37.5	2@+2.5%	2@-2.5%	DS-3	150	28	22	20	300	684	537	488	137	②	②	—	—	T42D21S37 <sup>③④</sup>	
50	2@+2.5%	2@-2.5%	DS-3	150	30	24	26	420	732	586	635	191	②	②	—	—	T42D21S50 <sup>③④</sup>	
<b>4160 Volts to 120/240 Volts</b>																		
1.5	—	—	EP	115	10-3/4	6-3/16	6-5/8	42	273	157	166	19	FR68	524G	—	—	S46N11S16N <sup>①</sup>	
3	—	4@-2.5%	EP	115	16	10-3/8	9-7/8	113	406	263	251	51	FR177	12B	—	—	S46J11S03N <sup>①</sup>	
5	—	4@-2.5%	EP	115	16	10-3/8	9-7/8	123	406	263	251	56	FR178	12B	—	—	S46J11S05N <sup>①</sup>	
10	—	4@-2.5%	EP	115	19	13-3/8	10-1/2	193	482	339	266	88	FR179	12B	—	—	S46J11S10A <sup>①</sup>	
15	—	4@-2.5%	EP	115	22-3/8	16-3/8	14-1/2	375	566	416	359	170	FR182	12B	—	—	S46J11S15A <sup>①</sup>	
25	2@+2.5%	2@-2.5%	DS-3	150	28	22	20	280	984	537	488	128	②	②	—	—	T46D11S25 <sup>③④</sup>	
37.5	2@+2.5%	2@-2.5%	DS-3	150	28	22	20	300	684	537	488	137	②	②	—	—	T46D11S37 <sup>③④</sup>	
50	2@+2.5%	2@-2.5%	DS-3	150	30	24	26	420	732	586	635	191	②	②	—	—	T46D11S50 <sup>③④</sup>	
75	2@+2.5%	2@-2.5%	DS-3	150	30	24	26	500	732	586	635	228	②	②	—	—	T46D11S75 <sup>③④</sup>	
100	2@+2.5%	2@-2.5%	DS-3	150	36	27	26	570	879	659	635	260	②	②	—	—	T46D11S99 <sup>③④</sup>	
167	2@+2.5%	2@-2.5%	DS-3	150	50	33	35	1000	1220	806	854	455	②	②	—	—	T46D11S67 <sup>③④</sup>	
<b>4160 Volts to 240/480 Volts</b>																		
37.5	2@+2.5%	2@-2.5%	DS-3	150	28	22	20	300	684	537	488	137	②	②	—	—	T46D21S37 <sup>③④</sup>	
50	2@+2.5%	2@-2.5%	DS-3	150	30	24	26	420	732	586	635	191	②	②	—	—	T46D21S50 <sup>③④</sup>	
75	2@+2.5%	2@-2.5%	DS-3	150	30	24	26	500	732	586	635	228	②	②	—	—	T46D21S75 <sup>③④</sup>	
100	2@+2.5%	2@-2.5%	DS-3	150	36	27	26	570	879	659	635	260	②	②	—	—	T46D21S99 <sup>③④</sup>	

- ① No UL label.
- ② Refer to your Eaton sales office.
- ③ NEMA 3R enclosure and/or UL label available at additional cost. Specify at time of order entry if required.
- ④ Not seismic qualified. Available by special order.

For other ratings or styles not shown, or for special enclosure types (including stainless steel), refer to Eaton.

Discount Symbol ..... DT-1

Single- and Three-Phase Types EP, DS-3, EPT, DT-3, 60 Hz

### Single- and Three-Phase, Types EP, DS-3, EPT, DT-3, 60 Hz



Type DT-3

### Product Description

#### Types EP, EPT

- Sand and Resin Encapsulated design.
- Suitable for indoor or outdoor applications.
- Totally enclosed, non-ventilated enclosures.
- Enclosures are NEMA 3R rated.
- Mountable in any position indoors and upright only outdoors.
- 185°C insulation system.
- 115°C rise standard; 80°C rise optional.
- Available in single-phase ratings through 37.5 kVA and 4160 volts primary (EP).
- Available in three-phase ratings through 75 kVA and 4160 volts primary (EPT).

#### Types DS-3, DT-3

- Ventilated, NEMA 2 enclosure standard.
- Suitable for indoor applications, outdoors when weathershields are also installed.
- Upright mounting only.
- 220°C insulation system.
- 150°C rise standard; 115°C or 80°C optional.
- Available in single-phase ratings 15 - 167 kVA and up to 4160 volts primary (DS-3).
- Available in three-phase ratings 15 - 1500 kVA and up to 4160 volts primary (DT-3).

### Application Description

Electrostatically shielded transformers are used to protect sensitive electrical equipment from undesirable high frequency signals commonly generated by lighting, switching surges, motors, and SCRs feeding noise back into the line. An electrostatic shield, consisting of a single turn of aluminum foil placed between the primary and secondary winding, is used to provide from 30 to 70 dB attenuation of wide band line-to-ground (common mode) noise.

#### Typical uses of shielded isolation transformers include:

- Suppression of transients and noise which travels from its source to the sensitive load equipment.
- Suppression of noise and transients at the point where the noise or transients are originating, thus preventing them from backfeeding from the source to the feeders.
- Transform one voltage level to another.
- Isolate one circuit from another.

### Features, Benefits and Functions

- UL listed.
- 60 Hz operation standard, 50/60 Hz operation available.
- Short-term overload capability as required by ANSI.
- Meet NEMA ST-20 sound levels.

### Standards and Certifications

#### Industry Standards

All Cutler-Hammer dry-type distribution and control transformers by Eaton Corporation are built and tested in accordance with applicable NEMA, ANSI and IEEE Standards. All 600 volt class transformers are UL listed unless otherwise noted.

#### Seismically Qualified

Cutler-Hammer manufactured dry-type distribution transformers are seismically qualified, and exceed requirements of the Uniform Building Code (UBC), International Building Code (IBC) and California Code Title 24.

The following pages provide listings for most standard transformer ratings and styles.

For other ratings or styles not shown, or for special enclosure types (including stainless steel), refer to Eaton.

### Product Specifications

#### Frequency

Cutler-Hammer standard dry-type distribution transformers are designed for 60 Hertz operation. Transformers required for other frequencies are available and must be specifically designed.

#### Overload Capability

Short-term overload is designed into transformers as required by ANSI. Dry-type distribution transformers will deliver 200% nameplate load for one-half hour; 150% load for one hour; and 125% load for four hours without being damaged provided that a constant 50% load precedes and follows the overload. See ANSI C57.96-01.250 for additional limitations.

Continuous overload capacity is not deliberately designed into a transformer because the design objective is to be within the allowed winding temperature rise with nameplate loading.

#### Insulation System and Temperature Rise

Industry standards classify insulation systems and rise as shown below:

Table 44-7. Insulation System Classification

Ambient	+ Winding Rise	+ Hot Spot	= Temp. Class
40°C	55°C	10°C	105°C
40°C	80°C	30°C	150°C
40°C	115°C	30°C	185°C
40°C	150°C	30°C	220°C

The design life of transformers having different insulation systems is the same — the lower temperature systems are designed for the same life as the higher temperature systems.

#### Enclosures

Cutler-Hammer ventilated transformers, Types DS-3 and DT-3 utilize a NEMA 2 rated (drip-proof) enclosure as standard, and are rated NEMA 3R with the addition of weathershields. Cutler-Hammer encapsulated transformers, Types EP and EPT, utilize a NEMA 3R rated enclosure as standard.

**Single- and Three-Phase, Types EP, 60 Hz**

**Sound Levels**

All Eaton's Cutler-Hammer 600 volt class general purpose dry-type distribution transformers are designed to meet NEMA ST-20 sound levels listed here. These are the sound levels measured in a soundproof environment. Actual sound levels measured at an installation will likely be higher due to electrical connections and environmental conditions. Lower sound levels are available and should be specified when the transformer is going to be installed in an area where sound may be a concern.

**Table 44-8. Average Sound Levels ①**

NEMA ST-20 Average Sound Level in dB			
kVA	Up to 1.2 kV		Above 1.2 kV
	Ventilated	Encapsulated	Ventilated
0 - 9	40	45	45
10 - 50	45	50	50
51 - 150	50	55	55
151 - 300	55	57	58
301 - 500	60	59	60
501 - 700	62	61	62
701 - 1000	64	63	64
1001 - 1500	65	64	65

① Currently being reviewed and revised by NEMA.

**Winding Terminations**

Primary and secondary windings are terminated in the wiring compartment. Encapsulated units have copper leads or stabs brought out for connections. Ventilated transformers have leads brought out to aluminum pads that are pre-drilled to accept Cu/Al lugs. **Lugs are not supplied with these transformers.** Eaton recommends external cables be rated 90°C (sized at 75°C ampacity) for encapsulated designs and 75°C for ventilated designs.

**Series-Multiple Windings**

Series-multiple windings consist of 2 similar coils in each winding which can be connected in series or parallel (multiple). Transformers with series-multiple windings are designated with an "X" or "/" between the voltage ratings, such as voltages of "120/240" or "240 X 480." If the series-multiple winding is designated by an "X," the winding can be connected only for a series or parallel. With the "/" designation, a mid-point also becomes available in addition to the series or parallel connection. As an example, a 120 X 240 winding can be connected for either 120 (parallel) or 240 (series), but a 120/240 winding can be connected for 120 (parallel), or 240 (series), or 240 with a 120 mid-point.

**Product Selection**

Additional Product Selection information begins on **Page 44-63**.

**Table 44-9. Single-Phase Selection Information — Types EP, 60 Hz**

kVA	Full Cap. Taps		Type	°C Temp. Rise	Dimensions (Inches)			Wt. Lbs.	Dimensions (mm)			Wt. kg	Frame	Wiring Diagram Number	Weathershield		Style Number	Price U.S. \$	
	FCAN	FCBN			H	W	D		H	W	D				Catalog Number	Price U.S. \$			
<b>120 x 240 Volts to 120/240 Volts</b>																			
3	—	—	EP	115	14-1/8	7-3/4	8	50	359	197	203	23	FR176	90B	Indoor- Outdoor		<b>S10N11E03N</b> <b>S10N11E05N</b> <b>S10N11E07N</b>		
5	—	—	EP	115	16	10-3/8	9-7/8	90	406	263	251	41	FR177	90B					
7.5	—	—	EP	115	16	10-3/8	9-7/8	123	406	263	251	56	FR178	90B					
10	—	—	EP	115	19	13-3/8	10-1/2	210	482	339	266	95	FR179	90B	Indoor- Outdoor		<b>S10N11E10N</b> <b>S10N11E15N</b> <b>S10N11E25N</b>		
15	—	—	EP	115	19	13-3/8	13-3/8	205	482	339	266	93	FR180	90B					
25	—	—	EP	115	22-3/8	16-3/8	14-1/2	375	568	416	359	170	FR182	90B					
<b>120 Volts to 120 Volts</b>																			
3	—	—	EP	115	14-1/8	7-3/4	8	60	359	197	203	27	FR176	77A	Indoor- Outdoor		<b>S12N12E03N</b> <b>S12N12E05N</b> <b>S12N12E07N</b>		
5	—	—	EP	115	16	10-3/8	9-7/8	100	406	263	251	45	FR177	77A					
7.5	—	—	EP	115	16	10-3/8	9-7/8	123	406	263	251	56	FR178	77A					
10	—	—	EP	115	19	13-3/8	10-1/2	180	482	339	266	82	FR179	77A	Indoor- Outdoor		<b>S12N12E10N</b> <b>S12N12E15N</b> <b>S12N12E25N</b>		
15	—	—	EP	115	19	13-3/8	13-3/8	216	482	339	266	98	FR180	77A					
25	—	—	EP	115	22-3/8	16-3/8	14-1/2	375	568	416	359	170	FR182	77A					
<b>208 Volts to 120/240 Volts</b>																			
3	—	—	EP	115	14-1/8	7-3/4	8	60	359	197	203	27	FR176	578A	Indoor- Outdoor		<b>S29N11E03N</b> <b>S29N11E05N</b> <b>S29N11E07N</b>		
5	—	—	EP	115	16	10-3/8	9-7/8	135	406	263	251	61	FR177	578A					
7.5	—	—	EP	115	16	10-3/8	9-7/8	95	406	263	251	43	FR178	578A					
10	—	—	EP	115	19	13-3/8	10-1/2	165	482	339	266	75	FR179	578A	Indoor- Outdoor		<b>S29N11E10N</b> <b>S29N11E15N</b> <b>S29N11E25N</b>		
15	—	—	EP	115	19	13-3/8	13-3/8	185	482	339	266	94	FR180	578A					
25	—	—	EP	115	22-3/8	16-3/8	14-1/2	375	568	416	359	170	FR182	578A					
<b>208 Volts to 208 Volts</b>																			
3	—	—	EP	115	14-1/8	7-3/4	8	65	359	197	203	30	FR176	77B	Indoor- Outdoor		<b>S29N29E03N</b> <b>S29N29E05N</b> <b>S29N29E07N</b>		
5	—	—	EP	115	16	10-3/8	9-7/8	113	406	263	251	51	FR177	77B					
7.5	—	—	EP	115	16	10-3/8	9-7/8	123	406	263	251	56	FR178	77B					
10	—	—	EP	115	19	13-3/8	10-1/2	195	482	339	266	89	FR179	77B	Indoor- Outdoor		<b>S29N29E10N</b> <b>S29N29E15N</b> <b>S29N29E25N</b>		
15	—	—	EP	115	19	13-3/8	13-3/8	216	482	339	266	98	FR180	77B					
25	—	—	EP	115	22-3/8	16-3/8	14-1/2	375	568	416	359	170	FR182	77B					

**Note:** Contact your local Eaton sales office for CE Mark transformer requirements.

For other ratings or styles not shown, or for special enclosure types (including stainless steel), refer to Eaton.

Discount Symbol ..... **DT-1**

Single-Phase, Types EP, DS-3, 60 Hz

Table 44-10. Single-Phase Selection Information — Types EP, DS-3, 60 Hz

kVA	Full Cap. Taps		Type	°C Temp. Rise	Dimensions (Inches)			Wt. Lbs.	Dimensions (mm)			Wt. kg	Frame	Wiring Diagram Number	Weathershield		Style Number	Price U.S. \$
	FCAN	FCBN			H	W	D		H	W	D				Catalog Number	Price U.S. \$		
<b>240 Volts to 240 Volts</b>																		
3	—	—	EP	115	14-1/8	7-3/4	8	65	359	197	203	30	FR176	77C	Indoor- Outdoor		S24N24E03N	
5	—	—	EP	115	16	10-3/8	9-7/8	113	406	263	251	51	FR177	77C			S24N24E05N	
7.5	—	—	EP	115	16	10-3/8	9-7/8	123	406	263	251	56	FR178	77C			S24N24E07N	
10	—	—	EP	115	19	13-3/8	10-1/2	193	482	339	266	88	FR179	77C	Indoor- Outdoor		S24N24E10N	
15	—	—	EP	115	19	13-3/8	13-3/8	216	482	339	266	98	FR180	77C			S24N24E15N	
25	—	—	EP	115	22-3/8	16-3/8	14-1/2	375	568	416	359	170	FR182	77C			S24N24E25N	
<b>277 Volts to 120/240 Volts</b>																		
3	—	—	EP	115	14-1/8	7-3/4	8	65	359	197	203	30	FR176	513B	Indoor- Outdoor		S27N11E03N	
5	—	—	EP	115	16	10-3/8	9-7/8	113	406	263	251	51	FR177	513B			S27N11E05N	
7.5	—	—	EP	115	16	10-3/8	9-7/8	75	406	263	251	34	FR178	513B			S27N11E07N	
10	—	—	EP	115	19	13-3/8	10-1/2	162	482	339	266	74	FR179	513B	Indoor- Outdoor		S27N11E10N	
15	—	—	EP	115	19	13-3/8	13-3/8	216	482	339	266	98	FR180	513B			S27N11E15N	
25	—	—	EP	115	22-3/8	16-3/8	14-1/2	375	568	416	359	170	FR182	513B			S27N11E25N	
<b>240 x 480 Volts to 120/240 Volts</b>																		
.25	—	—	EP	115	6-1/2	4-5/8	4-1/8	12	165	117	103	5	FR56	90A	Indoor- Outdoor		S20N11E26A	
.50	—	—	EP	115	6-1/2	4-5/8	4-15/16	16	165	117	125	7	FR57	90A			S20N11E51A	
.75	—	—	EP	115	8-5/8	5-3/4	5-3/4	26	219	146	146	12	FR58A	90A			S20N11E76A	
1	—	—	EP	115	8-5/8	5-3/4	5-3/4	31	219	146	146	14	FR59A	90A	Indoor- Outdoor		S20N11E01A	
1.5	—	—	EP	115	10-3/4	6-3/16	6-5/8	42	273	157	166	19	FR67	90A			S20N11E16A	
2	—	—	EP	115	10-3/4	6-3/16	6-5/8	42	273	157	166	19	FR68	90A			S20N11E02A	
3	—	—	EP	115	14-1/8	7-11/16	8	65	359	195	203	30	FR176	90A	Indoor- Outdoor		S20N11E03A	
5	—	—	EP	115	16	10-3/8	9-7/8	113	406	263	251	51	FR177	90A			S20N11E05A	
7.5	—	—	EP	115	16	10-3/8	9-7/8	123	406	263	251	56	FR178	90A			S20N11E07A	
10	—	—	EP	115	19	13-3/8	10-1/2	166	482	339	266	75	FR179	90A	Indoor- Outdoor		S20N11E10A	
15	—	—	EP	115	19	13-3/8	13-3/8	216	482	339	266	98	FR180	90A			S20N11E15A	
25	①	①	EP	115	22-3/8	16-3/8	14-1/2	375	568	416	359	170	FR182	526A			S20L11E25A	
15	②	②	DS-3	150	30-1/4	16-7/8	15-7/8	147	768	428	402	67	FR815	261A	WS15 WS11 WS11		T20P11E15 ③	
25	②	②	DS-3	150	31-1/4	22-5/8	17-1/2	212	793	574	445	96	FR816	261A			T20P11E25 ③	
37.5	②	②	DS-3	150	37-5/8	22-5/8	19-1/2	306	953	574	495	139	FR817	261A			T20P11E37 ③	
50	②	②	DS-3	150	37-5/8	22-5/8	19-1/2	340	953	574	495	154	FR818	261A	WS11 WS16 WS16		T20P11E50 ③	
75	②	②	DS-3	150	42-1/8	24	23-3/8	510	1070	610	594	232	FR819	261A			T20P11E75 ③	
100	②	②	DS-3	150	42-1/8	24	23-3/8	600	1070	610	594	272	FR820	261A			T20P11E99 ③	

① 2@+5% FCBN at 240 volts; 4@-2.5% FCBN at 480 volts.

② 1@+5%, 2@-5% at 240 volts primary; 2@+2.5%, 4@-2.5% at 480 volts primary.

③ Do not meet Federal Energy Efficiency standards that are effective January 1, 2007. Cannot be purchased for use in the United States or territories.

**Note:** Contact your local Eaton sales office for CE Mark transformer requirements.

For other ratings or styles not shown, or for special enclosure types (including stainless steel), refer to Eaton.

Discount Symbol ..... DT-1

**Table 44-11. Three-Phase Selection Information — Types EPT, DT-3, 60 Hz**

kVA	Full Cap. Taps		Type	°C Temp. Rise	Dimensions (Inches)			Wt. Lbs.	Dimensions (mm)			Wt. kg	Frame	Wiring Diagram Number	Weathershield		Style Number	Price U.S. \$	
	FCAN	FCBN			H	W	D		H	W	D				Catalog Number	Price U.S. \$			
<b>208 Δ Volts to 208Y/120 Volts</b>																			
15	2@+2.5%	2@-2.5%	EPT	115	17-3/8	20	10-9/16	275	441	508	267	125	FR95	86A	Indoor-Outdoor		Y29D28E15B <sup>①</sup>		
15	2@+2.5%	4@-2.5%	DT-3	150	25	20-1/8	14-1/8	152	635	511	359	69	FR909	283A	WS31		V29M28E15A <sup>②</sup>		
30	2@+2.5%	4@-2.5%	DT-3	150	30	20-1/8	14-1/8	230	762	511	359	104	FR910A	283A	WS31		V29M28E30B <sup>②</sup>		
45	2@+2.5%	4@-2.5%	DT-3	150	30	20-1/8	14-3/8	310	762	511	364	140	FR912A	283A	WS31		V29M28E45B <sup>②</sup>		
75	2@+2.5%	4@-2.5%	DT-3	150	39-1/4	26-1/8	19-1/8	480	995	663	486	218	FR914B	283A	WS33		V29M28E75B <sup>②</sup>		
112.5	1@+5%	2@-5%	DT-3	150	39-1/4	26-1/8	19-1/8	600	995	663	485	272	FR915B	325A	WS33		V29R28E12B <sup>②</sup>		
150	1@+5%	2@-5%	DT-3	150	46-5/8	28	23	870	1183	710	584	395	FR916A	325A	WS19		V29R28E49B <sup>②</sup>		
225	1@+5%	2@-5%	DT-3	150	62-1/4	31-1/4	30-1/4	1600	1581	794	768	728	FR918A	287A	WS34		V29R28E22B <sup>②</sup>		
300	1@+5%	2@-5%	DT-3	150	62-1/4	31-1/4	30-1/4	1600	1581	794	768	728	FR918A	287A	WS34		V29R28E33B <sup>②</sup>		
<b>480 Δ Volts to 208Y/120 Volts</b>																			
3	2@+2.5%	2@-2.5%	EPT	115	13-3/8	15-15/16	8-5/16	116	340	405	211	52	FR201	86B	Indoor-Outdoor		Y48D28E03A <sup>①</sup>		
6	2@+2.5%	2@-2.5%	EPT	115	15-7/8	16-1/2	9-7/8	165	403	419	251	75	FR200	86B			Y48D28E06A <sup>①</sup>		
9	2@+2.5%	2@-2.5%	EPT	115	15-7/8	16-1/2	9-7/8	190	403	419	251	86	FR103	86B			Y48D28E09N <sup>①</sup>		
15	2@+2.5%	2@-2.5%	EPT	115	17-3/8	20	10-9/16	275	441	508	267	125	FR95	86B			Y48D28E15B <sup>①</sup>		
15	2@+2.5%	4@-2.5%	DT-3	150	25	20-1/8	14-1/8	152	635	511	359	69	FR909	283B	WS31		V48M28E15B <sup>②</sup>		
30	2@+2.5%	4@-2.5%	DT-3	150	30	20-1/8	14-1/8	230	762	511	359	104	FR910A	283B	WS31		V48M28E30B <sup>②</sup>		
45	2@+2.5%	4@-2.5%	DT-3	150	30	20-1/8	14-3/8	325	762	511	364	148	FR912A	283B	WS31		V48M28E45 <sup>②</sup>		
75	2@+2.5%	4@-2.5%	DT-3	150	39-1/4	26-1/8	19-1/8	515	995	663	486	234	FR914B	283B	WS33		V48M28E75 <sup>②</sup>		
112.5	2@+2.5%	4@-2.5%	DT-3	150	46-5/8	28	23	870	1183	710	584	395	FR916A	283B	WS19		V48M28E12B <sup>②</sup>		
150	2@+2.5%	4@-2.5%	DT-3	150	46-5/8	28	23	870	1183	710	584	395	FR916A	283B	WS19		V48M28E49 <sup>②</sup>		
225	2@+2.5%	4@-2.5%	DT-3	150	56-1/4	31-1/4	24-1/4	1200	1427	790	616	545	FR917	292A	WS34		V48M28E22 <sup>②</sup>		
300	2@+2.5%	4@-2.5%	DT-3	150	57-1/2	36-1/4	32-1/4	1710	1460	921	817	776	FR923	292A	WS37		V48M28E33 <sup>②</sup>		
500	2@+2.5%	4@-2.5%	DT-3	150	75	44-1/2	36	2500	1905	1130	914	1135	FR919	292A	WS35		V48M28E55G <sup>②</sup>		
750	2@+2.5%	4@-2.5%	DT-3	150	75	44-1/2	36	2900	1905	1130	914	1315	FR920	292A	WS35		V48M28E77B <sup>②</sup>		
1000	1@+3.5%	1@-2.5%	DT-3	150	③	③	③	③	③	③	③	③	③	③	③			V48W28E11A <sup>④</sup>	
<b>480 Δ Volts to 208Y/120 Volts — Copper Windings</b>																			
15	2@+2.5%	4@-2.5%	DT-3	150	25	20-1/8	14-1/8	172	635	511	359	78	FR909	283B	WS31		V48M28E15CU <sup>②</sup>		
30	2@+2.5%	4@-2.5%	DT-3	150	30	20-1/8	14-1/8	300	762	511	359	136	FR910A	283B	WS31		V48M28E30CU <sup>②</sup>		
45	2@+2.5%	4@-2.5%	DT-3	150	30	20-1/8	14-3/8	370	762	511	364	168	FR912A	283B	WS31		V48M28E45CU <sup>②</sup>		
75	2@+2.5%	4@-2.5%	DT-3	150	39-1/4	26-1/8	19-1/8	600	995	663	485	272	FR915B	283B	WS33		V48M28E75CU <sup>②</sup>		
112.5	2@+2.5%	4@-2.5%	DT-3	150	39-1/4	26-1/8	19-1/8	675	995	663	485	306	FR915B	283B	WS33		V48M28E12CU <sup>②</sup>		
150	2@+2.5%	4@-2.5%	DT-3	150	46-5/8	28	23	900	1183	710	584	409	FR916A	283B	WS19		V48M28E49CU <sup>②</sup>		
225	2@+2.5%	4@-2.5%	DT-3	150	56-1/4	31-1/4	24-1/4	1200	1427	790	616	545	FR917	283B	WS34		V48M28E22CU <sup>②</sup>		
300	2@+2.5%	4@-2.5%	DT-3	150	62-1/4	31-1/4	30-1/4	2150	1581	794	768	977	FR918A	283B	WS34		V48M28E33CU <sup>②</sup>		
500	2@+2.5%	4@-2.5%	DT-3	150	75	44-1/2	36	3100	1905	1130	914	1407	FR919	292A	WS35		V48M28E55CU <sup>②</sup>		
<b>480 Δ Volts to 480Y/277 Volts</b>																			
9	2@+2.5%	2@-2.5%	EPT	115	15-7/8	16-1/2	9-7/8	190	403	419	251	86	FR103	86C	Indoor-Outdoor		Y48D47E09N <sup>①</sup>		
15	2@+2.5%	2@-2.5%	EPT	115	17-3/8	20	10-9/16	275	441	508	267	125	FR95	86C			Y48D47E15B <sup>①</sup>		
30	2@+2.5%	4@-2.5%	DT-3	150	30	20-1/8	14-1/8	230	762	511	359	104	FR910A	283B	WS31		V48M47E30B <sup>②</sup>		
45	2@+2.5%	4@-2.5%	DT-3	150	30	20-1/8	14-3/8	310	762	511	364	140	FR912A	283B	WS31		V48M47E45B <sup>②</sup>		
75	2@+2.5%	4@-2.5%	DT-3	150	39-1/4	26-1/8	19-1/8	480	995	663	486	218	FR914B	283B	WS33		V48M47E75B <sup>②</sup>		
112.5	2@+2.5%	4@-2.5%	DT-3	150	39-1/4	26-1/8	19-1/8	600	995	663	485	272	FR915B	283B	WS33		V48M47E12B <sup>②</sup>		
150	2@+2.5%	4@-2.5%	DT-3	150	46-5/8	28	23	950	1183	710	584	431	FR916A	283B	WS19		V48M47E49B <sup>②</sup>		
225	2@+2.5%	4@-2.5%	DT-3	150	56-1/4	31-1/4	24-1/4	1100	1427	790	616	499	FR917	283B	WS34		V48M47E22B <sup>②</sup>		
300	2@+2.5%	4@-2.5%	DT-3	150	62-1/4	31-1/4	30-1/4	1600	1581	794	768	728	FR918A	283B	WS34		V48M47E33B <sup>②</sup>		
500	2@+2.5%	4@-2.5%	DT-3	150	75	44-1/2	36	2400	1905	1130	914	1088	FR919	292A	WS35		V48M47E55G <sup>②</sup>		
750	2@+2.5%	4@-2.5%	DT-3	150	75	44-1/2	36	2900	1905	1130	914	1315	FR920	292A	WS35		V48M47E77A <sup>②</sup>		

- ① T-T connected secondary.
- ② Do not meet Federal Energy Efficiency standards that are effective January 1, 2007. Cannot be purchased for use in the United States or territories.
- ③ Refer to your Eaton sales office.
- ④ Not seismic qualified. Available by special order.

**Note:** Contact your local Eaton sales office for CE Mark transformer requirements.

For other ratings or styles not shown, or for special enclosure types (including stainless steel), refer to Eaton.

Discount Symbol ..... DT-1

Three-Phase, Types EPT, DT-3, 60 Hz

Table 44-12. Three-Phase Selection Information — Types EPT, DT-3, 60 Hz

kVA	Full Cap. Taps		Type	°C Temp. Rise	Dimensions (Inches)			Wt. Lbs.	Dimensions (mm)			Wt. kg	Frame	Wiring Diagram Number	Weathershield		Style Number	Price U.S. \$
	FCAN	FCBN			H	W	D		H	W	D				Catalog Number	Price U.S. \$		
<b>480 Δ Volts to 240 Δ Volts</b>																		
3	—	2@-5%	EPT	115	13-3/8	15-15/16	8-5/16	116	340	405	211	52	FR201	88A	Indoor- Outdoor		Y48G24E03A	①
6	—	2@-5%	EPT	115	15-7/8	16-1/2	9-7/8	165	403	419	251	75	FR200	88A		Y48G24E06A	①	
9	—	4@-2.5%	EPT	115	15-7/8	16-1/2	9-7/8	195	403	419	251	89	FR103	505B		Y48J24E09A	①	
15	—	4@-2.5%	EPT	115	17-3/8	20	10-9/16	275	441	508	267	125	FR95	505B		Y48J24E15A	①	
<b>480 Δ Volts to 240 Δ Volts With 120 Volt Lighting Tap on B Phase ②</b>																		
15	2@+2.5%	4@-2.5%	DT-3	150	25	20-1/8	14-1/8	152	635	511	359	69	FR909	284B	WS31		V48M22E15B	③
30	2@+2.5%	4@-2.5%	DT-3	150	30	20-1/8	14-1/8	230	762	511	359	104	FR910A	284B	WS31		V48M22E30A	③
45	2@+2.5%	4@-2.5%	DT-3	150	30	20-1/8	14-3/8	310	762	511	364	140	FR912A	284B	WS31		V48M22E45A	③
75	2@+2.5%	4@-2.5%	DT-3	150	39-1/4	26-1/8	19-1/8	480	995	663	486	218	FR914B	284B	WS33		V48M22E75A	③
112.5	2@+2.5%	4@-2.5%	DT-3	150	39-1/4	26-1/8	19-1/8	600	995	663	485	272	FR915B	284B	WS33		V48M22E12A	③
150	2@+2.5%	4@-2.5%	DT-3	150	46-5/8	28	23	785	1183	710	584	356	FR916A	284B	WS19		V48M22E49A	③
225	2@+2.5%	4@-2.5%	DT-3	150	56-1/4	31-1/4	24-1/4	1100	1427	790	616	499	FR917	284B	WS34		V48M22E22A	③
300	2@+2.5%	4@-2.5%	DT-3	150	62-1/4	31-1/4	30-1/4	1600	1581	794	768	728	FR918A	284B	WS34		V48M22E33A	③
500	2@+2.5%	4@-2.5%	DT-3	150	75	44-1/2	36	2400	1905	1130	914	1088	FR919	293A	WS35		V48M22E55A	③

① T-T connected secondary.

② Center Tap capacity limited to 5% of rated kVA.

③ Do not meet Federal Energy Efficiency standards that are effective January 1, 2007. Cannot be purchased for use in the United States or territories.

**Note:** Contact your local Eaton sales office for CE Mark transformer requirements.

For other ratings or styles not shown, or for special enclosure types (including stainless steel), refer to Eaton.

Discount Symbol ..... DT-1

**Single- and Three-Phase, Types DS-3C, DT-3C, 60 Hz**

**Product Description**

- 220°C insulation system, 150°C rise standard; 115°C or 80°C optional.
- Aluminum windings (copper optional).

**Application Description**

The basic purpose of a transformer is voltage transformation as near as practically possible to the load for economy and distribution of power. Typical loads for dry-type distribution transformers include lighting, heating, air conditioners, fans, and machine tools. Such loads are found in commercial, institutional, industrial, and residential structures.

Open core and coil assemblies are typically used by panel builders and equipment OEM customers who incorporate the entire transformer into their structures. A versatile option to purchasing a standard, enclosed transformer and discarding the unneeded enclosure parts.

**Features, Benefits and Functions**

-  (UL recognized).
- 60 Hz operation standard, 50/60 Hz operation available.
- Short-term overload capability as required by ANSI.
- Meet NEMA ST-20 sound levels.

**Standards and Certifications**

**Industry Standards**

All Cutler-Hammer dry-type distribution and control transformers by Eaton Corporation are built and tested in accordance with applicable NEMA, ANSI, and IEEE Standards.

**Seismically Qualified**

All Cutler-Hammer manufactured dry-type distribution transformers are seismically qualified, and exceed requirements of the Uniform Building Code (UBC), International Building Code and California Code Title 24.

**Product Specifications**

**Frequency**

Cutler-Hammer standard dry-type distribution transformers are designed for 60 Hz operation. Transformers required for other frequencies are available and must be specifically designed.

**Overload Capability**

Short-term overload is designed into transformers as required by ANSI. Dry-type distribution transformers will deliver 200% nameplate load for one-half hour; 150% load for one-hour; and 125% load for four-hours without being damaged provided that a constant 50% load precedes and follows the overload. See ANSI C57.96-01.250 for additional limitations.

Continuous overload capacity is not deliberately designed into a transformer because the design objective is to be within the allowed winding temperature rise with nameplate loading.

**Insulation System and Temperature Rise**

Industry standards classify insulation systems and rise as shown below:

**Table 44-13. Insulation System Classification**

Ambient	+ Winding Rise	+ Hot Spot	= Temp. Class
40°C	55°C	10°C	105°C
40°C	80°C	30°C	150°C
40°C	115°C	30°C	185°C
40°C	150°C	30°C	220°C

The design life of transformers having different insulation systems is the same — the lower temperature systems are designed for the same life as the higher temperature systems.

**Sound Levels**

All Cutler-Hammer 600 volt class general purpose dry-type distribution transformers are designed to meet NEMA ST-20 sound levels listed here. These are the sound levels measured in a soundproof environment. Actual sound levels measured at an installation will likely be higher due to electrical connections and environmental conditions. Lower sound levels are available and should be specified when the transformer is going to be installed in an area where sound may be a concern.

**Table 44-14. Average Sound Levels** ①

NEMA ST-20 Average Sound Level in dB			
kVA	Up to 1.2 kV		Above 1.2 kV
	Ventilated	Encapsulated	Ventilated
0 – 9	40	45	45
10 – 50	45	50	50
51 – 150	50	55	55
151 – 300	55	57	58
301 – 500	60	59	60
501 – 700	62	61	62
701 – 1000	64	63	64
1001 – 1500	65	64	65

① Currently being reviewed and revised by NEMA.

**Winding Terminations**

**Lugs are not supplied with these transformers.** Eaton recommends external cables be rated 90°C (sized at 75°C ampacity) for encapsulated designs and 75°C for ventilated designs.

**Series-Multiple Windings**

Series-multiple windings consist of 2 similar coils in each winding which can be connected in series or parallel (multiple). Transformers with series-multiple windings are designated with an "X" or "/" between the voltage ratings, such as voltages of "120/240" or "240 X 480." If the series-multiple winding is designated by an "X," the winding can be connected only for a series or parallel. With the "/" designation, a mid-point also becomes available in addition to the series or parallel connection. As an example, a 120 X 240 winding can be connected for either 120 (parallel) or 240 (series), but a 120/240 winding can be connected for 120 (parallel), or 240 (series), or 240 with a 120 mid-point.

The following pages provide listings for most standard transformer ratings and styles.  
 For other ratings or styles not shown, refer to Eaton.

Single- and Three-Phase

Product Selection

Additional Product Selection information begins on Page 44-63.

Table 44-15. Single-Phase Selection Information — Type DS-3C, 60 Hz

kVA	Full Cap. Taps		Type	°C Temp. Rise	Dimensions (Inches)			Wt. Lbs.	Dimensions (mm)			Wt. kg	Frame	Wiring Diagram Number	Style Number	Price U.S. \$
	FCAN	FCBN			H	W	D		H	W	D					
<b>240 x 480 Volts to 120/240 Volts</b>																
15	①	①	DS-3C	150	30-1/4	16-7/8	15-7/8	147	768	428	402	67	FR815C	3XA	T20P11S15ZZ	
25	①	①	DS-3C	150	31-1/4	22-5/8	17-1/2	212	793	574	445	96	FR816C	3XA	T20P11S25ZZ	
37.5	①	①	DS-3C	150	37-5/8	22-5/8	19-1/2	306	953	574	495	139	FR817C	3XA	T20P11S37ZZ	
50	①	①	DS-3C	150	37-5/8	22-5/8	19-1/2	340	953	574	495	154	FR818C	3XA	T20P11S50ZZ	

① 1@+5%, 2@-5% at 240 volts primary; 2@+2.5%, 4@-2.5% at 480 volts primary.

Table 44-16. Three-Phase Selection Information — Type DT-3C, 60 Hz

kVA	Full Cap. Taps		Type	°C Temp. Rise	Dimensions (Inches)			Wt. Lbs.	Dimensions (mm)			Wt. kg	Frame	Wiring Diagram Number	Style Number	Price U.S. \$
	FCAN	FCBN			H	W	D		H	W	D					
<b>480 Δ Volts to 208Y/120 Volts</b>																
15	2@+2.5%	4@-2.5%	DT-3C	150	20-5/16	20-1/8	14	128	516	511	356	58	FR909C	280B	V48M28T15ZZ	
30	2@+2.5%	4@-2.5%	DT-3C	150	23-13/16	20-1/8	14	195	605	511	356	89	FR910C	280B	V48M28T30ZZ	
45	2@+2.5%	4@-2.5%	DT-3C	150	24-3/4	20-1/8	14	250	629	511	356	114	FR912C	280B	V48M28T45ZZ	
75	2@+2.5%	4@-2.5%	DT-3C	150	29-3/8	25-5/16	19	395	746	643	483	180	FR914AC	280B	V48M28T75ZZ	
112.5	2@+2.5%	4@-2.5%	DT-3C	150	31-3/8	25-5/16	19	530	797	643	483	241	FR915C	280B	V48M28T12ZZ	
150	2@+2.5%	4@-2.5%	DT-3C	150	41-7/16	25-5/16	20	656	1052	643	508	298	FR916C	280B	V48M28T49ZZ	

Note: Contact your local Eaton sale offices for availability of additional Open Type Core and Coil Assemblies.

Note: Contact your local Eaton sales office for CE Mark transformer requirements.

For other ratings or styles not shown, refer to Eaton.

Discount Symbol ..... DT-1

**Single- and Three-Phase Applications, 60 Hz**



Type EP

**Product Description**

**Types EP, EPT**

- Sand and Resin Encapsulated design.
- Suitable for indoor or outdoor applications.
- Totally enclosed, non-ventilated enclosures.
- Enclosures are NEMA 3R rated.
- Mountable in any position indoors and upright only outdoors.
- 185°C insulation system.
- 115°C rise standard; 80°C rise optional.
- Available in single-phase ratings through 7.5 kVA.

**Application Description**

A buck-boost transformer is used to provide an economical method of correcting a lower or higher voltage rating more suitable for efficient operation of electrical equipment. Type EP Buck-Boost transformers are small kVA, single-phase transformers with dual primary and dual secondary windings and are usually connected as autotransformers by utilizing one unit for single-phase applications and either two or three units banked for three-phase operation. They are primarily used for motor operation and should not be used for motor control circuits, to correct fluctuating line voltage or to obtain a neutral on a delta system. Buck-boost transformers are ideally suited for use with low voltage lighting systems, such as outdoor lighting.

**Features, Benefits and Functions**

- UL listed.
- 60 Hz operation.
- 600 volt class insulation.
- Short-term overload capability as required by ANSI.
- Meet NEMA ST-20 sound levels.

**Standards and Certifications**

**Industry Standards**

All Cutler-Hammer dry-type distribution and control transformers by Eaton Corporation are built and tested in accordance with applicable NEMA, ANSI and IEEE Standards. All 600 volt class transformers are UL listed unless otherwise noted.

**Seismically Qualified**

Cutler-Hammer manufactured dry-type distribution transformers are seismically qualified, and exceed requirements of the Uniform Building Code (UBC), International Building Code (IBC) and California Code Title 24.

**Product Specifications**

**Frequency**

Cutler-Hammer buck-boost transformers are designed for 60 Hz operation.

**Overload Capability**

Short-term overload is designed into transformers as required by ANSI. Dry-type distribution transformers will deliver 200% nameplate load for one-half hour; 150% load for one-hour; and 125% load for four-hours without being damaged provided that a constant 50% load precedes and follows the overload. See ANSI C57.96-01.250 for additional limitations.

Continuous overload capacity is not deliberately designed into a transformer because the design objective is to be within the allowed winding temperature rise with nameplate loading.

**Insulation System and Temperature Rise**

Industry standards classify insulation systems and rise as shown below:

**Table 44-17. Insulation System Classification**

Ambient	+ Winding Rise	+ Hot Spot	= Temp. Class
40°C	55°C	10°C	105°C
40°C	80°C	30°C	150°C
40°C	115°C	30°C	185°C
40°C	150°C	30°C	220°C

The design life of transformers having different insulation systems is the same — the lower temperature systems are designed for the same life as the higher temperature systems.

**Enclosures**

Cutler-Hammer encapsulated buck-boost transformers utilize a NEMA 3R rated enclosure.

**Sound Levels**

All Cutler-Hammer 600 volt class general purpose dry-type distribution transformers are designed to meet NEMA ST-20 sound levels listed here. These are the sound levels measured in a soundproof environment. Actual sound levels measured at an installation will likely be higher due to electrical connections and environmental conditions. Lower sound levels are available and should be specified when the transformer is going to be installed in an area where sound may be a concern.

**Table 44-18. Average Sound Levels ①**

NEMA ST-20 Average Sound Level in dB	
kVA	Up to 1.2 kV
	Encapsulated
0 – 9	45
10 – 50	50
51 – 150	55
151 – 300	57
301 – 500	59
501 – 700	61
701 – 1000	63
1001 – 1500	64

① Currently being reviewed and revised by NEMA.

**Winding Terminations**

Primary and secondary windings are terminated in the wiring compartment. Encapsulated units have copper leads or stabs brought out for connections. **Lugs are not supplied with these transformers.** Eaton recommends external cables be rated 90°C (sized at 75°C ampacity) for encapsulated designs.

## Single- and Three-Phase

### Series-Multiple Windings

Series-multiple windings consist of 2 similar coils in each winding which can be connected in series or parallel (multiple). Transformers with series-multiple windings are designated with an "X" or "/" between the voltage ratings, such as voltages of "120/240" or "240 X 480." If the series-multiple winding is designated by an "X," the winding can be connected only for a series or parallel. With the "/" designation, a mid-point also becomes available in addition to the series or parallel connection. As an example, a 120 X 240 winding can be connected for either 120 (parallel) or 240 (series), but a 120/240 winding can be connected for 120 (parallel), or 240 (series), or 240 with a 120 mid-point.

**Note:** When installation is to be made on a grounded system, consideration must be given to the resulting voltage. Thus, on a 208 grounded wye/120 system the voltage can be boosted to 240 volts but the voltage to ground will be 139 volts. If 240/120 volts with a mid-point ground is needed, a standard two-winding transformer must be used.

The following formulas can be used to calculate specific requirements.

For Single-Phase:

$$\text{LOAD kVA} = \frac{\text{Load Voltage} \times \text{Full Line Amperes}}{1000}$$

For Three-Phase:

$$\text{LOAD kVA} = \frac{\text{Line Load Voltage} \times 1.73 \times \text{Full Load Amperes}}{1000}$$

### Product Selection

For quick selection data, refer to the tables on the following pages.

#### Selection Requirements

You should have the following information before selecting a buck-boost transformer.

##### Line Voltage

The voltage that you want to buck (decrease) or boost (increase). This can be found by measuring the supply line voltage with a voltmeter.

##### Load Voltage

The voltage at which your equipment is designed to operate. This is listed on the nameplate of the load equipment.

##### Load Amperes or Load kVA

You do not need to know both — one or the other is sufficient for selection purposes. This information usually can be found on the nameplate of the equipment that you want to operate.

##### Frequency

The supply line frequency must be the same as the frequency of the equipment to be operated — Eaton's Cutler-Hammer Buck-Boost Transformers operate at 60 Hz only.

##### Phase

The supply line should be the same as the equipment to be operated — either single or three-phase.

#### Transformer Interconnection

For three-phase applications, interconnections of transformers should be made in a junction box. Two or three transformers may be used depending on an open delta (2) or wye (3) connection.

### 5-Step Selector

The tables which follow will simplify the selection of the buck-boost transformers. There are no calculations needed; simply follow these 5 steps.

1. Refer to the table having the same output voltage as the equipment you want to operate. For example, if you are installing a 240 volt 6 kVA single-phase load use Selection **Table 44-23**.
2. Select the available line voltage across the top of the chart which is closest to the actual supply voltage. Therefore, for example, if the available line voltage is 213 volts, use the 212 volt column.
3. Read down the column until you reach an output kVA or amps rating equal to or greater than the load requirements. Since 6 kVA, in the example, is not listed, use the next higher rating or 7.5 kVA.
4. Read across to the far left columns for the catalog number and quantity of transformers for your application. In this case, you will need one (1) catalog number S10N06A01N.
5. Connect the buck-boost transformer(s) you have selected in accordance with the connection diagram specified at the bottom of the available line voltage column. In this example, Diagram "F" would be used.

**Note:** For 1-phase connections and 3-phase open delta connections, inputs and outputs may be reversed. kVA capacity remains constant.

Additional Product Selection information begins on **Page 44-63**.

**Wiring Diagrams**

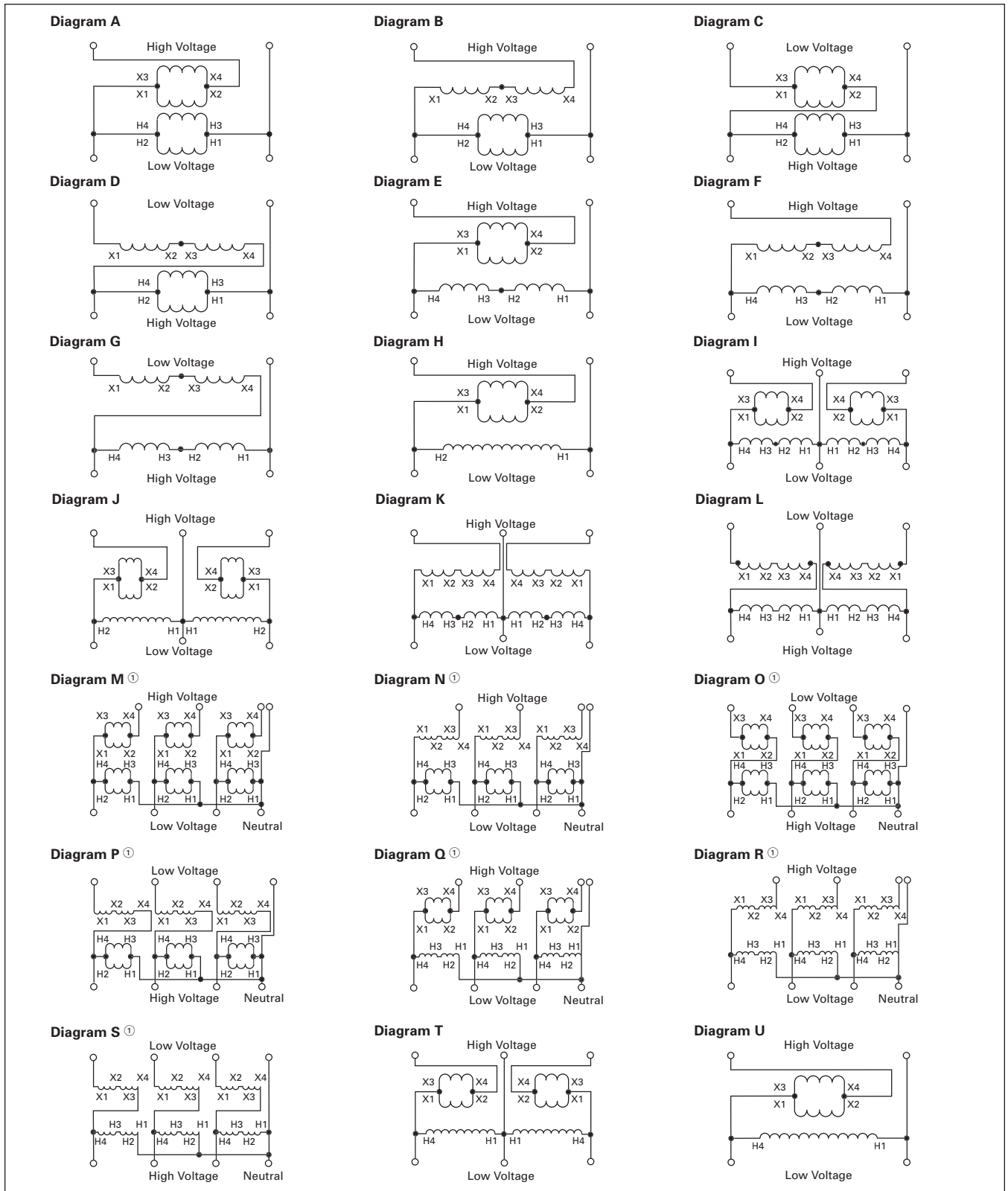

**Figure 44-1. Buck-Boost Transformers Wiring Diagrams**

Ⓢ **WARNING!** If input is 3-wire, “neutral” connection must be isolated and insulated! When used to supply a 3-phase, 4-wire load, the source must be 3-phase, 4-wire wye.

**Single- and Three-Phase**

**Table 44-19. Selection Information**

kVA	°C Temp. Rise	Dimensions (Inches)			Weight Lbs.	Dimensions (mm)			Weight kg	Frame	Style Number	Price U.S. \$
		Height	Width	Depth		Height	Width	Depth				
<b>120 x 240 Volts to 12/24 Volts</b>												
.05	115	6-1/2	3-7/8	3-1/2	7	165	98	89	3	FR52	S10N04A81N	
.10	115	6-1/2	3-7/8	3-1/2	7	165	98	89	3	FR54	S10N04A82N	
.15	115	6-1/2	3-7/8	3-1/2	8	165	98	89	4	FR55	S10N04A83N	
.25	115	6-1/2	4-7/8	3-7/8	12	165	124	98	5	FR56	S10N04A26N	
.50	115	6-1/2	4-7/8	4-5/8	13	165	124	117	5	FR57	S10N04A51N	
.75	115	8-3/8	6	5-3/4	21	213	152	146	10	FR58A	S10N04A76N	
1	115	8-3/8	6	5-3/4	31	213	152	146	14	FR59A	S10N04A01N	
1.5	115	10-3/4	6-3/16	6-1/8	40	273	157	156	18	FR67	S10N04A16N	
2	115	10-3/4	6-3/16	6-1/8	40	273	157	156	18	FR68	S10N04A02N	
3	115	14-1/8	7-11/16	8	65	359	195	203	29	FR176	S10N04A03N	
5	115	16	10-3/8	9-7/8	113	406	263	251	51	FR177	S10N04A05N	
7.5	115	16	10-3/8	9-7/8	123	406	263	251	55	FR178	S10N04A07N	
<b>120 x 240 Volts to 16/32 Volts</b>												
.05	115	6-1/2	3-7/8	3-1/2	7	165	98	89	3	FR52	S10N06A81N	
.10	115	6-1/2	3-7/8	3-1/2	7	165	98	89	3	FR54	S10N06A82N	
.15	115	6-1/2	3-7/8	3-1/2	8	165	98	89	4	FR55	S10N06A83N	
.25	115	6-1/2	4-7/8	3-7/8	12	165	124	98	5	FR56	S10N06A26N	
.50	115	6-1/2	4-7/8	4-5/8	13	165	124	117	5	FR57	S10N06A51N	
.75	115	8-3/8	6	5-3/4	21	213	152	146	10	FR58A	S10N06A76N	
1	115	8-3/8	6	5-3/4	31	213	152	146	14	FR59A	S10N06A01N	
1.5	115	10-3/4	6-3/16	6-1/8	40	273	157	156	18	FR67	S10N06A16N	
2	115	10-3/4	6-3/16	6-1/8	40	273	157	156	18	FR68	S10N06A02N	
3	115	14-1/8	7-11/16	8	65	359	195	203	29	FR176	S10N06A03N	
5	115	16	10-3/8	9-7/8	113	406	263	251	51	FR177	S10N06A05N	
7.5	115	16	10-3/8	9-7/8	123	406	263	251	55	FR178	S10N06A07N	
<b>240 x 480 Volts to 24/48 Volts</b>												
.05	115	6-1/2	3-7/8	3-1/2	7	165	98	89	3	FR52	S20N08A81N	
.10	115	6-1/2	3-7/8	3-1/2	7	165	98	89	3	FR54	S20N08A82N	
.15	115	6-1/2	3-7/8	3-1/2	8	165	98	89	4	FR55	S20N08A83N	
.25	115	6-1/2	4-7/8	3-7/8	12	165	124	98	5	FR56	S20N08A26N	
.50	115	6-1/2	4-7/8	4-5/8	13	165	124	117	5	FR57	S20N08A51N	
.75	115	8-3/8	6	5-3/4	21	213	152	146	10	FR58A	S20N08A76N	
1	115	8-3/8	6	5-3/4	31	213	152	146	14	FR59A	S20N08A01N	
1.5	115	10-3/4	6-3/16	6-1/8	40	273	157	156	18	FR67	S20N08A16N	
2	115	10-3/4	6-3/16	6-1/8	40	273	157	156	18	FR68	S20N08A02N	
3	115	14-1/8	7-11/16	8	65	359	195	203	29	FR176	S20N08A03N	
5	115	16	10-3/8	9-7/8	113	406	263	251	51	FR177	S20N08A05N	
7.5	115	16	10-3/8	9-7/8	123	406	263	251	55	FR178	S20N08A07N	

**Single-Phase**

**Table 44-20. Single-Phase 115 Volt Output Required, 60 Hz**

Units Required ①	Unit kVA	Input Available Voltage										Style Number	Price U.S. \$
		84		91		96		100		102			
		Output		Output		Output		Output		Output			
		kVA	Amps	kVA	Amps	kVA	Amps	kVA	Amps	kVA	Amps		
1	.05	—	—	—	—	.24	2.09	—	—	—	—	S10N04A81N	
1	.05	.13	1.14	.18	1.56	—	—	.31	2.70	.36	3.13	S10N06A81N	
1	.10	—	—	—	—	.48	4.17	—	—	—	—	S10N04A82N	
1	.10	.26	2.29	.36	3.12	—	—	.62	5.41	.72	6.25	S10N06A82N	
1	.15	—	—	—	—	.72	6.25	—	—	—	—	S10N04A83N	
1	.15	.39	3.44	.54	4.69	—	—	.93	8.12	1.08	9.37	S10N06A83N	
1	.25	—	—	—	—	1.2	10.4	—	—	—	—	S10N04A26N	
1	.25	.659	5.73	.899	7.81	—	—	1.56	13.5	1.8	15.6	S10N06A26N	
1	.50	—	—	—	—	2.4	20.8	—	—	—	—	S10N04A51N	
1	.50	1.32	11.5	1.8	15.6	—	—	3.11	27.1	3.59	31.2	S10N06A51N	
1	.75	—	—	—	—	3.6	31.2	—	—	—	—	S10N04A76N	
1	.75	1.98	17.2	2.7	23.4	—	—	4.67	40.6	5.39	46.8	S10N06A76N	
1	1	—	—	—	—	4.79	41.7	—	—	—	—	S10N04A01N	
1	1	2.64	22.9	3.59	31.2	—	—	6.23	54.1	7.19	62.5	S10N06A01N	
1	1.5	—	—	—	—	7.2	62.5	—	—	—	—	S10N04A16N	
1	1.5	3.95	34.4	5.39	46.9	—	—	9.34	81.2	10.8	93.7	S10N06A16N	
1	2	—	—	—	—	9.58	83.3	—	—	—	—	S10N04A02N	
1	2	5.27	45.8	7.19	62.5	—	—	12.5	108	14.4	125	S10N06A02N	
1	3	—	—	—	—	14.37	125.1	—	—	—	—	S10N04A03N	
1	3	7.92	68.7	10.77	93.6	—	—	18.69	162.3	21.57	187.5	S10N06A03N	
1	5	—	—	—	—	23.95	208.5	—	—	—	—	S10N04A05N	
1	5	13.2	115	18	156	—	—	31.15	270.5	35.95	312.5	S10N06A05N	
1	7.5	—	—	—	—	36	312	—	—	—	—	S10N04A07N	
1	7.5	19.8	172	27	234	—	—	46.7	406	53.9	468	S10N06A07N	
Connection Diagram ②		D		B		B		C		A			

Units Required ①	Unit kVA	Input Available Voltage										Style Number	Price U.S. \$
		105		127		130		138		146			
		Output		Output		Output		Output		Output			
		kVA	Amps	kVA	Amps	kVA	Amps	kVA	Amps	kVA	Amps		
1	.05	.48	4.17	.54	4.58	—	—	.29	2.5	—	—	S10N04A81N	
1	.05	—	—	—	—	.41	3.54	—	—	.23	1.98	S10N06A81N	
1	.10	.96	8.33	1.1	9.17	—	—	.58	5.0	—	—	S10N04A82N	
1	.10	—	—	—	—	.82	7.08	—	—	.46	3.95	S10N06A82N	
1	.15	1.44	12.5	1.6	13.7	—	—	.87	7.5	—	—	S10N04A83N	
1	.15	—	—	—	—	1.3	10.6	—	—	.69	5.93	S10N06A83N	
1	.25	2.39	20.8	2.63	22.9	—	—	1.44	12.5	—	—	S10N04A26N	
1	.25	—	—	—	—	2.03	17.7	—	—	1.14	9.88	S10N06A26N	
1	.50	4.79	41.6	5.27	45.8	—	—	2.87	25	—	—	S10N04A51N	
1	.50	—	—	—	—	4.07	35.4	—	—	2.27	19.8	S10N06A51N	
1	.75	7.19	62.4	7.9	68.7	—	—	4.31	37.5	—	—	S10N04A76N	
1	.75	—	—	—	—	6.1	53.1	—	—	3.41	29.6	S10N06A76N	
1	1	9.58	83.3	10.5	91.7	—	—	5.75	50	—	—	S10N04A01N	
1	1	—	—	—	—	8.14	70.8	—	—	4.55	39.5	S10N06A01N	
1	1.5	14.4	125	15.8	137	—	—	8.62	75	—	—	S10N04A16N	
1	1.5	—	—	—	—	12.2	106	—	—	6.82	59.3	S10N06A16N	
1	2	19.2	16.7	21.1	183	—	—	11.5	100	—	—	S10N04A02N	
1	2	—	—	—	—	16.3	142	—	—	9.10	79.2	S10N06A02N	
1	3	28.7	249.9	31.5	275.1	—	—	17.3	150	—	—	S10N04A03N	
1	3	—	—	—	—	24.4	212.4	—	—	13.6	118.5	S10N06A03N	
1	5	47.9	416.5	52.5	458.5	—	—	28.7	250	—	—	S10N04A05N	
1	5	—	—	—	—	40.7	354	—	—	22.7	197.5	S10N06A05N	
1	7.5	71.9	624	79	687	—	—	43.1	357	—	—	S10N04A07N	
1	7.5	—	—	—	—	61	531	—	—	34.1	296	S10N06A07N	
Connection Diagram ②		A		A		A		B		B			

① Additional wiring trough may be required.

② Refer to Page 44-17 for Buck-Boost wiring diagrams.

**Note:** Output voltage for lower input voltage can be found by:  $\frac{\text{Rated Output Voltage}}{\text{Rated Input Voltage}} \times \text{Input Actual Voltage} = \text{Output New Voltage}$ .

**Note:** Output kVA available at reduced input voltage can be found by:  $\frac{\text{Actual Input Voltage}}{\text{Rated Input Voltage}} \times \text{Output kVA} = \text{New kVA Rating}$ .

Discount Symbol ..... DT-1

Single-Phase

Table 44-21. Single-Phase 120 Volt Output Required, 60 Hz

Units Required ①	Unit kVA	Input Available Voltage										Style Number	Price U.S. \$
		88		95		100		104		106			
		Output		Output		Output		Output		Output			
		kVA	Amps	kVA	Amps	kVA	Amps	kVA	Amps	kVA	Amps		
1	.05	—	—	—	—	.25	2.09	—	—	—	—	S10N04A81N	
1	.05	.14	1.15	.19	1.56	—	—	.33	2.70	.38	3.13	S10N06A81N	
1	.10	—	—	—	—	.50	4.17	—	—	—	—	S10N04A82N	
1	.10	.28	2.29	.38	3.12	—	—	.65	5.41	.75	6.25	S10N06A82N	
1	.15	—	—	—	—	.75	6.25	—	—	—	—	S10N04A83N	
1	.15	.41	3.44	.56	4.69	—	—	.98	8.12	1.12	9.37	S10N06A83N	
1	.25	—	—	—	—	1.25	10.4	—	—	—	—	S10N04A26N	
1	.25	.687	5.73	.937	7.81	—	—	1.62	13.5	1.87	15.6	S10N06A26N	
1	.50	—	—	—	—	2.5	20.8	—	—	—	—	S10N04A51N	
1	.50	1.37	11.5	1.87	15.6	—	—	3.25	27.1	3.75	31.2	S10N06A51N	
1	.75	—	—	—	—	3.75	31.2	—	—	—	—	S10N04A76N	
1	.75	2.06	17.2	2.82	23.4	—	—	4.87	40.6	5.62	46.8	S10N06A76N	
1	1	—	—	—	—	5	41.7	—	—	—	—	S10N04A01N	
1	1	2.75	22.9	3.75	31.2	—	—	6.5	54.1	7.5	62.5	S10N06A01N	
1	1.5	—	—	—	—	7.5	62.5	—	—	—	—	S10N04A16N	
1	1.5	4.12	34.4	5.62	46.9	—	—	9.75	81.2	11.2	93.7	S10N06A16N	
1	2	—	—	—	—	10	83.3	—	—	—	—	S10N04A02N	
1	2	5.5	45.8	7.5	62.5	—	—	13	108	15	125	S10N06A02N	
1	3	—	—	—	—	15	125.1	—	—	—	—	S10N04A03N	
1	3	8.25	68.7	11.25	93.6	—	—	19.5	162.3	22.5	187.5	S10N06A03N	
1	5	—	—	—	—	25	208.5	—	—	—	—	S10N04A05N	
1	5	13.75	114.5	18.75	156	—	—	32.5	270.5	37.5	312.5	S10N06A05N	
1	7.5	—	—	—	—	37.5	312	—	—	—	—	S10N04A07N	
1	7.5	20.6	172	28.2	234	—	—	48.7	406	56.2	468	S10N06A07N	
Connection Diagram ②		D		B		B		C		A			

44

Units Required ①	Unit kVA	Input Available Voltage										Style Number	Price U.S. \$
		109		132		136		144		152			
		Output		Output		Output		Output		Output			
		kVA	Amps	kVA	Amps	kVA	Amps	kVA	Amps	kVA	Amps		
1	.05	.5	4.17	.55	4.58	—	—	.3	2.5	—	—	S10N04A81N	
1	.05	—	—	—	—	.43	3.54	—	—	.24	1.98	S10N06A81N	
1	.10	1.0	8.33	1.1	9.17	—	—	.6	5.0	—	—	S10N04A82N	
1	.10	—	—	—	—	.85	7.08	—	—	.48	3.95	S10N06A82N	
1	.15	1.5	12.5	1.6	13.7	—	—	.9	7.5	—	—	S10N04A83N	
1	.15	—	—	—	—	1.27	10.6	—	—	.71	5.93	S10N06A83N	
1	.25	2.5	20.8	2.75	22.9	—	—	1.5	12.5	—	—	S10N04A26N	
1	.25	—	—	—	—	2.12	17.7	—	—	1.19	9.88	S10N06A26N	
1	.50	5	41.6	5.5	45.8	—	—	3	25	—	—	S10N04A51N	
1	.50	—	—	—	—	4.25	35.4	—	—	2.37	19.8	S10N06A51N	
1	.75	7.5	62.4	8.25	68.7	—	—	4.5	37.5	—	—	S10N04A76N	
1	.75	—	—	—	—	6.37	53.1	—	—	3.56	29.6	S10N06A76N	
1	1	10	83.3	11	91.7	—	—	6	50	—	—	S10N04A01N	
1	1	—	—	—	—	8.5	70.8	—	—	4.75	39.5	S10N06A01N	
1	1.5	15	125	16.5	137	—	—	9	75	—	—	S10N04A16N	
1	1.5	—	—	—	—	12.7	106	—	—	7.12	59.3	S10N06A16N	
1	2	20	167	22	183	—	—	12	100	—	—	S10N04A02N	
1	2	—	—	—	—	17	142	—	—	9.5	79.2	S10N06A02N	
1	3	30	249.9	33	275.1	—	—	18	150	—	—	S10N04A03N	
1	3	—	—	—	—	25.5	212.4	—	—	14.25	118.5	S10N06A03N	
1	5	50	416.5	55	458.5	—	—	30	250	—	—	S10N04A05N	
1	5	—	—	—	—	42.5	354	—	—	23.7	197.5	S10N06A05N	
1	7.5	75	624	82.5	687	—	—	45	375	—	—	S10N04A07N	
1	7.5	—	—	—	—	63.7	531	—	—	35.6	296	S10N06A07N	
Connection Diagram ②		A		A		A		B		B			

① Additional wiring trough may be required.

② Refer to Page 44-17 for Buck-Boost wiring diagrams.

**Note:** Output voltage for lower input voltage can be found by:  $\frac{\text{Rated Output Voltage}}{\text{Rated Input Voltage}} \times \text{Input Actual Voltage} = \text{Output New Voltage}$ .

**Note:** Output kVA available at reduced input voltage can be found by:  $\frac{\text{Actual Input Voltage}}{\text{Rated Input Voltage}} \times \text{Output kVA} = \text{New kVA Rating}$ .

Discount Symbol ..... DT-1

**Single-Phase**

**Table 44-22. Single-Phase 230 Volt Output Required, 60 Hz**

Units Required ①	Unit kVA	Input Available Voltage										Style Number	Price U.S. \$
		199		203		207		209		216			
		Output kVA	Amps	Output kVA	Amps	Output kVA	Amps	Output kVA	Amps	Output kVA	Amps		
1	.05	—	—	—	—	.43	1.88	.48	2.08	—	—	S10N04A81N	
1	.05	.31	1.36	.36	1.56	—	—	—	—	.72	3.12	S10N06A81N	
1	.10	—	—	—	—	.86	3.75	.96	4.17	—	—	S10N04A82N	
1	.10	.62	2.71	.72	3.12	—	—	—	—	1.44	6.25	S10N06A82N	
1	.15	—	—	—	—	1.29	5.62	1.44	6.25	—	—	S10N04A83N	
1	.15	.93	4.06	1.08	4.69	—	—	—	—	2.16	9.37	S10N06A83N	
1	.25	—	—	—	—	2.15	9.37	2.39	10.4	—	—	S10N04A26N	
1	.25	1.55	6.77	1.8	7.81	—	—	—	—	3.59	15.6	S10N06A26N	
1	.50	—	—	—	—	4.31	18.7	4.79	20.8	—	—	S10N04A51N	
1	.50	3.11	13.5	3.6	15.6	—	—	—	—	7.19	31.2	S10N06A51N	
1	.75	—	—	—	—	6.46	28.2	7.19	31.2	—	—	S10N04A76N	
1	.75	4.66	20.3	5.4	23.4	—	—	—	—	10.8	46.8	S10N06A76N	
1	1	—	—	—	—	8.62	37.5	9.58	41.7	—	—	S10N04A01N	
1	1	6.23	27.1	7.2	31.2	—	—	—	—	14.4	62.5	S10N06A01N	
1	1.5	—	—	—	—	12.9	56.2	14.4	62.5	—	—	S10N04A16N	
1	1.5	9.34	40.6	10.8	46.9	—	—	—	—	21.6	93.7	S10N06A16N	
1	2	—	—	—	—	17.2	75	19.2	83.3	—	—	S10N04A02N	
1	2	12.5	54.2	14.4	62.5	—	—	—	—	28.7	125	S10N06A02N	
1	3	—	—	—	—	25.8	112.5	28.7	125.1	—	—	S10N04A03N	
1	3	18.6	81.3	21.6	93.6	—	—	—	—	43.2	187.5	S10N06A03N	
1	5	—	—	—	—	43.1	187.5	47.9	208.5	—	—	S10N04A05N	
1	5	31.1	135.5	36	156	—	—	—	—	72	312.5	S10N06A05N	
1	7.5	—	—	—	—	64.6	282	71.9	312	—	—	S10N04A07N	
1	7.5	46.6	203	54	234	—	—	—	—	108	468	S10N06A07N	
Connection Diagram ②		G		F		G		F		E			

Units Required ①	Unit kVA	Input Available Voltage										Style Number	Price U.S. \$
		219		242		246		253		260			
		Output kVA	Amps	Output kVA	Amps	Output kVA	Amps	Output kVA	Amps	Output kVA	Amps		
1	.05	.96	4.16	1.0	4.38	—	—	.53	2.29	—	—	S10N04A81N	
1	.05	—	—	—	—	.77	3.34	—	—	.41	1.77	S10N06A81N	
1	.10	1.92	8.33	2.01	8.75	—	—	1.05	4.58	—	—	S10N04A82N	
1	.10	—	—	—	—	1.53	6.67	—	—	.82	3.54	S10N06A82N	
1	.15	2.87	12.5	3.02	13.1	—	—	1.58	6.87	—	—	S10N04A83N	
1	.15	—	—	—	—	2.3	10.0	—	—	1.22	5.31	S10N06A83N	
1	.25	4.79	20.8	5.03	21.9	—	—	2.63	11.5	—	—	S10N04A26N	
1	.25	—	—	—	—	3.83	16.7	—	—	2.04	8.85	S10N06A26N	
1	.50	9.58	41.6	10.1	43.7	—	—	5.27	22.9	—	—	S10N04A51N	
1	.50	—	—	—	—	7.67	33.3	—	—	4.07	17.7	S10N06A51N	
1	.75	14.4	62.4	15.1	65.6	—	—	7.9	34.4	—	—	S10N04A76N	
1	.75	—	—	—	—	11.5	50	—	—	6.11	26.6	S10N06A76N	
1	1	19.2	83.3	20.1	87.5	—	—	10.5	45.8	—	—	S10N04A01N	
1	1	—	—	—	—	15.3	66.7	—	—	8.15	35.4	S10N06A01N	
1	1.5	28.7	125	30.2	131	—	—	15.8	68.7	—	—	S10N04A16N	
1	1.5	—	—	—	—	23	100	—	—	12.2	53.1	S10N06A16N	
1	2	38.3	167	40.2	175	—	—	21.1	91.7	—	—	S10N04A02N	
1	2	—	—	—	—	30.7	133	—	—	16.3	70.8	S10N06A02N	
1	3	57.6	249.9	60.3	262.5	—	—	31.5	137.4	—	—	S10N04A03N	
1	3	—	—	—	—	45.9	200.1	—	—	24.4	106.2	S10N06A03N	
1	5	96	416.5	100.5	437.5	—	—	52.5	229	—	—	S10N04A05N	
1	5	—	—	—	—	76.5	333.5	—	—	40.7	177	S10N06A05N	
1	7.5	144	624	151	656	—	—	79	344	—	—	S10N04A07N	
1	7.5	—	—	—	—	115	500	—	—	61.1	266	S10N06A07N	
Connection Diagram ②		E		E		E		F		F			

① Additional wiring trough may be required.

② Refer to Page 44-17 for Buck-Boost wiring diagrams.

**Note:** Output voltage for lower input voltage can be found by:  $\frac{\text{Rated Output Voltage}}{\text{Rated Input Voltage}} \times \text{Input Actual Voltage} = \text{Output New Voltage}$ .

**Note:** Output kVA available at reduced input voltage can be found by:  $\frac{\text{Actual Input Voltage}}{\text{Rated Input Voltage}} \times \text{Output kVA} = \text{New kVA Rating}$ .

Single-Phase

Table 44-23. Single-Phase 240 Volt Output Required, 60 Hz

Units Required ①	Unit kVA	Input Available Voltage										Style Number	Price U.S. \$
		208		212		216		218		225			
		Output		Output		Output		Output		Output			
		kVA	Amps	kVA	Amps	kVA	Amps	kVA	Amps	kVA	Amps		
1	.05	—	—	—	—	.45	1.88	.5	2.08	—	—	S10N04A81N S10N06A81N S10N04A82N	
1	.05	.32	1.35	.38	1.56	—	—	—	—	.75	3.12		
1	.10	—	—	—	—	.9	3.75	1.0	4.17	—	—		
1	.10	.65	2.71	.75	3.12	—	—	—	—	1.5	6.25	S10N06A82N S10N04A83N S10N06A83N	
1	.15	—	—	—	—	1.35	5.62	1.5	6.25	—	—		
1	.15	.98	4.06	1.12	4.69	—	—	—	—	2.25	9.37		
1	.25	—	—	—	—	2.25	9.37	2.5	10.4	—	—	S10N04A26N S10N06A26N S10N04A51N	
1	.25	1.62	6.77	1.87	7.81	—	—	—	—	3.75	15.6		
1	.50	—	—	—	—	4.5	18.7	5	20.8	—	—		
1	.50	3.25	13.5	3.75	15.6	—	—	—	—	7.5	31.2	S10N06A51N S10N04A76N S10N06A76N	
1	.75	—	—	—	—	6.75	28.2	7.5	31.2	—	—		
1	.75	4.87	20.3	5.62	23.4	—	—	—	—	11.2	46.8		
1	1	—	—	—	—	9	37.5	10	41.7	—	—	S10N04A01N S10N06A01N S10N04A16N	
1	1	6.5	27.1	7.5	31.2	—	—	—	—	15	62.5		
1	1.5	—	—	—	—	13.5	56.2	15	62.5	—	—		
1	1.5	9.75	40.6	11.2	46.9	—	—	—	—	22.5	93.7	S10N06A16N S10N04A02N S10N06A02N	
1	2	—	—	—	—	18	75	20	83.3	—	—		
1	2	13	54.2	15	62.5	—	—	—	—	30	125		
1	3	—	—	—	—	27	112.5	30	125.1	—	—	S10N04A03N S10N06A03N S10N04A05N	
1	3	19.5	81.3	22.5	93.6	—	—	—	—	45	187.5		
1	5	—	—	—	—	45	187	50	208	—	—		
1	5	32.5	135	37.5	156	—	—	—	—	75	312	S10N06A05N S10N04A07N S10N06A07N	
1	7.5	—	—	—	—	67.5	282	75	312	—	—		
1	7.5	48.7	203	56.2	234	—	—	—	—	112	468		
Connection Diagram ②		G		F		G		F		E			

44

Units Required ①	Unit kVA	Input Available Voltage										Style Number	Price U.S. \$
		229		252		256		264		272			
		Output		Output		Output		Output		Output			
		kVA	Amps	kVA	Amps	kVA	Amps	kVA	Amps	kVA	Amps		
1	.05	1.0	4.16	1.05	4.38	—	—	.55	2.29	—	—	S10N04A81N S10N06A81N S10N04A82N	
1	.05	—	—	—	—	.8	3.33	—	—	.42	1.77		
1	.10	2.0	8.33	2.1	8.75	—	—	1.1	4.58	—	—		
1	.10	—	—	—	—	1.6	6.67	—	—	.85	3.54	S10N06A82N S10N04A83N S10N06A83N	
1	.15	3.0	12.5	3.15	13.1	—	—	1.65	6.87	—	—		
1	.15	—	—	—	—	2.4	10.0	—	—	1.27	5.31		
1	.25	5	20.8	5.25	21.9	—	—	2.75	11.5	—	—	S10N04A26N S10N06A26N S10N04A51N	
1	.25	—	—	—	—	4	16.7	—	—	2.12	8.85		
1	.50	10	41.6	10.5	43.7	—	—	5.5	22.9	—	—		
1	.50	—	—	—	—	8	33.3	—	—	4.25	17.7	S10N06A51N S10N04A76N S10N06A76N	
1	.75	15	62.4	15.7	65.6	—	—	8.25	34.4	—	—		
1	.75	—	—	—	—	12	50	—	—	6.37	26.6		
1	1	20	83.3	21	87.5	—	—	11	45.8	—	—	S10N04A01N S10N06A01N S10N04A16N	
1	1	—	—	—	—	16	66.7	—	—	8.5	35.4		
1	1.5	30	125	31.5	131	—	—	16.5	68.7	—	—		
1	1.5	—	—	—	—	24	100	—	—	12.7	53.1	S10N06A16N S10N04A02N S10N06A02N	
1	2	40	167	42	175	—	—	22	91.7	—	—		
1	2	—	—	—	—	32	133	—	—	17	70.8		
1	3	60	249.9	63	262.5	—	—	33	137.4	—	—	S10N04A03N S10N06A03N S10N04A05N	
1	3	—	—	—	—	48	200.1	—	—	25.5	106.2		
1	5	100	416.5	105	437.5	—	—	55	229	—	—		
1	5	—	—	—	—	80	333	—	—	42.5	177	S10N06A05N S10N04A07N S10N06A07N	
1	7.5	150	624	157	656	—	—	82.5	344	—	—		
1	7.5	—	—	—	—	120	500	—	—	63.7	266		
Connection Diagram ②		E		E		E		F		F			

① Additional wiring trough may be required.

② Refer to Page 44-17 for Buck-Boost wiring diagrams.

**Note:** Output voltage for lower input voltage can be found by:  $\frac{\text{Rated Output Voltage}}{\text{Rated Input Voltage}} \times \text{Input Actual Voltage} = \text{Output New Voltage}$ .

**Note:** Output kVA available at reduced input voltage can be found by:  $\frac{\text{Actual Input Voltage}}{\text{Rated Input Voltage}} \times \text{Output kVA} = \text{New kVA Rating}$ .

Discount Symbol ..... DT-1

**Three-Phase**

**Table 44-24. Three-Phase Open Delta Connection 230 Volt Output Required, 60 Hz**

Units Required ①	Unit kVA	Input Available Voltage										Style Number	Price U.S. \$
		199		203		207		209		216			
		Output		Output		Output		Output		Output			
		kVA	Amps	kVA	Amps	kVA	Amps	kVA	Amps	kVA	Amps		
2	.05	—	—	—	—	.75	1.87	.83	2.08	—	—	S10N04A81N	
2	.05	.54	1.35	.62	1.56	—	—	—	—	1.24	3.12	S10N06A81N	
2	.10	—	—	—	—	1.49	3.75	1.66	4.17	—	—	S10N04A82N	
2	.10	1.08	2.71	1.24	3.12	—	—	—	—	2.49	6.25	S10N06A82N	
2	.15	—	—	—	—	2.24	5.62	2.49	6.25	—	—	S10N04A83N	
2	.15	1.62	4.06	1.87	4.69	—	—	—	—	3.73	9.37	S10N06A83N	
2	.25	—	—	—	—	3.3	9.37	4.15	10.4	—	—	S10N04A26N	
2	.25	2.7	6.77	3.11	7.81	—	—	—	—	6.22	15.6	S10N06A26N	
2	.50	—	—	—	—	7.47	18.7	8.3	20.8	—	—	S10N04A51N	
2	.50	5.39	13.5	6.22	15.6	—	—	—	—	12.4	31.2	S10N06A51N	
2	.75	—	—	—	—	11.2	28.2	12.4	31.2	—	—	S10N04A76N	
2	.75	8.09	20.3	9.33	23.4	—	—	—	—	18.7	46.8	S10N06A76N	
2	1	—	—	—	—	14.9	37.5	16.6	41.7	—	—	S10N04A01N	
2	1	10.8	27.1	12.4	31.2	—	—	—	—	24.9	62.5	S10N06A01N	
2	1.5	—	—	—	—	22.4	56.2	24.9	62.5	—	—	S10N04A16N	
2	1.5	16.2	40.6	18.7	46.9	—	—	—	—	37.3	93.7	S10N06A16N	
2	2	—	—	—	—	29.9	75	33.2	83.3	—	—	S10N04A02N	
2	2	21.6	54.2	24.9	62.5	—	—	—	—	49.8	125	S10N06A02N	
2	3	—	—	—	—	44.7	112.5	49.8	125.1	—	—	S10N04A03N	
2	3	32.4	81.3	32.7	93.6	—	—	—	—	74.7	187.5	S10N06A03N	
2	5	—	—	—	—	74.7	187	83	208	—	—	S10N04A05N	
2	5	53.9	135	62.2	156	—	—	—	—	124	312.5	S10N06A05N	
2	7.5	—	—	—	—	112	282	124	312	—	—	S10N04A07N	
2	7.5	80.9	203	93.3	234	—	—	—	—	187	468	S10N06A07N	
Connection Diagram ②		L		K		L		K		I			

Units Required ①	Unit kVA	Input Available Voltage										Style Number	Price U.S. \$
		219		242		246		253		260			
		Output		Output		Output		Output		Output			
		kVA	Amps	kVA	Amps	kVA	Amps	kVA	Amps	kVA	Amps		
2	.05	1.66	4.17	1.74	4.37	—	—	.91	2.29	—	—	S10N04A81N	
2	.05	—	—	—	—	1.33	3.33	—	—	.70	1.77	S10N06A81N	
2	.10	3.32	8.33	3.48	8.75	—	—	1.83	4.58	—	—	S10N04A82N	
2	.10	—	—	—	—	2.65	6.67	—	—	1.41	3.54	S10N06A82N	
2	.15	4.98	12.5	5.23	13.1	—	—	2.74	6.87	—	—	S10N04A83N	
2	.15	—	—	—	—	3.98	10.0	—	—	2.12	5.13	S10N06A83N	
2	.25	8.3	20.8	8.71	21.9	—	—	4.56	11.5	—	—	S10N04A26N	
2	.25	—	—	—	—	6.64	16.7	—	—	3.52	8.85	S10N06A26N	
2	.50	16.6	41.7	17.4	43.7	—	—	9.73	22.9	—	—	S10N04A51N	
2	.50	—	—	—	—	13.3	33.3	—	—	7.05	17.7	S10N06A51N	
2	.75	24.9	62.4	26.1	65.6	—	—	13.7	34.4	—	—	S10N04A76N	
2	.75	—	—	—	—	19.9	50	—	—	10.6	26.6	S10N06A76N	
2	1	33.2	83.3	34.8	87.5	—	—	18.3	45.8	—	—	S10N04A01N	
2	1	—	—	—	—	26.5	66.7	—	—	14.1	35.4	S10N06A01N	
2	1.5	49.8	125	52.3	131	—	—	27.4	68.7	—	—	S10N04A16N	
2	1.5	—	—	—	—	39.8	100	—	—	21.2	53.1	S10N06A16N	
2	2	66.4	167	69.7	175	—	—	36.5	91.7	—	—	S10N04A02N	
2	2	—	—	—	—	53.1	133	—	—	28.2	70.8	S10N06A02N	
2	3	99.6	249.9	104.4	262.5	—	—	54.9	137.4	—	—	S10N04A03N	
2	3	—	—	—	—	79.5	200	—	—	42.3	106.2	S10N06A03N	
2	5	166	417	174	437	—	—	91.3	229	—	—	S10N04A05N	
2	5	—	—	—	—	133	333	—	—	70.5	177	S10N06A05N	
2	7.5	249	624	261	656	—	—	137	344	—	—	S10N04A07N	
2	7.5	—	—	—	—	199	500	—	—	106	266	S10N06A07N	
Connection Diagram ②		I		I		I		K		K			

① Additional wiring trough may be required.

② Refer to Page 44-17 for Buck-Boost wiring diagrams.

**Note:** Output voltage for lower input voltage can be found by:  $\frac{\text{Rated Output Voltage}}{\text{Rated Input Voltage}} \times \text{Input Actual Voltage} = \text{Output New Voltage}$ .

**Note:** Output kVA available at reduced input voltage can be found by:  $\frac{\text{Actual Input Voltage}}{\text{Rated Input Voltage}} \times \text{Output kVA} = \text{New kVA Rating}$ .

Three-Phase

Table 44-25. Three-Phase Open Delta Connection 240 Volt Output Required, 60 Hz

Units Required ①	Unit kVA	Input Available Voltage										Style Number	Price U.S. \$
		208		212		216		218		225			
		Output		Output		Output		Output		Output			
		kVA	Amps	kVA	Amps	kVA	Amps	kVA	Amps	kVA	Amps		
2	.05	—	—	—	—	.73	1.87	.87	2.08	—	—	S10N04A81N S10N06A81N S10N04A82N	
2	.05	.56	1.35	.65	1.56	—	—	—	—	1.3	3.12		
2	.10	—	—	—	—	1.56	3.75	1.73	4.17	—	—		
2	.10	1.13	2.71	1.3	3.12	—	—	—	—	2.6	6.25	S10N06A82N S10N04A83N S10N06A83N	
2	.15	—	—	—	—	2.34	5.62	2.6	6.25	—	—		
2	.15	1.69	4.06	1.95	4.69	—	—	—	—	3.9	9.37		
2	.25	—	—	—	—	3.9	9.37	4.33	10.4	—	—	S10N04A26N S10N06A26N S10N04A51N	
2	.25	2.81	6.77	3.25	7.81	—	—	—	—	6.49	15.6		
2	.50	—	—	—	—	7.79	18.7	8.66	20.8	—	—		
2	.50	5.63	13.5	6.5	15.6	—	—	—	—	13	31.2	S10N06A51N S10N04A76N S10N06A76N	
2	.75	—	—	—	—	11.7	28.2	13	31.2	—	—		
2	.75	8.44	20.3	9.75	23.4	—	—	—	—	19.5	46.8		
2	1	—	—	—	—	15.6	37.5	17.3	41.7	—	—	S10N04A01N S10N06A01N S10N04A16N	
2	1	11.3	27.1	13	31.2	—	—	—	—	26	62.5		
2	1.5	—	—	—	—	23.4	56.2	26	62.5	—	—		
2	1.5	16.9	40.6	19.5	46.9	—	—	—	—	39	93.7	S10N06A16N S10N04A02N S10N06A02N	
2	2	—	—	—	—	31.2	75	34.6	83.3	—	—		
2	2	22.5	54.2	26	62.5	—	—	—	—	52	125		
2	3	—	—	—	—	46.8	112.5	51.9	125.1	—	—	S10N04A03N S10N06A03N S10N04A05N	
2	3	33.9	81.3	39	93.6	—	—	—	—	78	187.5		
2	5	—	—	—	—	77.9	187	86.6	208	—	—		
2	5	56.3	135	65	156	—	—	—	—	130	312	S10N06A05N S10N04A07N S10N06A07N	
2	7.5	—	—	—	—	117	282	130	312	—	—		
2	7.5	84.4	203	97.5	234	—	—	—	—	195	468		
Connection Diagram ②		L		K		L		K		I			

44

Units Required ①	Unit kVA	Input Available Voltage										Style Number	Price U.S. \$
		229		252		256		264		272			
		Output		Output		Output		Output		Output			
		kVA	Amps	kVA	Amps	kVA	Amps	kVA	Amps	kVA	Amps		
2	.05	1.73	4.16	1.82	4.37	—	—	.95	2.29	—	—	S10N04A81N S10N06A81N S10N04A82N	
2	.05	—	—	—	—	1.38	3.33	—	—	.74	1.77		
2	.10	3.46	8.33	3.64	8.75	—	—	1.91	4.58	—	—		
2	.10	—	—	—	—	2.77	6.67	—	—	1.47	3.54	S10N06A82N S10N04A83N S10N06A83N	
2	.15	5.19	12.5	5.45	13.1	—	—	2.86	6.87	—	—		
2	.15	—	—	—	—	4.15	10.0	—	—	2.21	5.31		
2	.25	8.66	20.8	9.09	21.9	—	—	4.76	11.5	—	—	S10N04A26N S10N06A26N S10N04A51N	
2	.25	—	—	—	—	6.92	16.7	—	—	3.68	8.85		
2	.50	17.3	41.6	18.2	43.7	—	—	9.53	22.9	—	—		
2	.50	—	—	—	—	13.8	33.3	—	—	7.36	17.7	S10N06A51N S10N04A76N S10N06A76N	
2	.75	26	62.4	27.3	65.6	—	—	14.3	34.4	—	—		
2	.75	—	—	—	—	20.8	50	—	—	11	26.6		
2	1	34.6	83.3	36.4	87.5	—	—	19.1	45.8	—	—	S10N04A01N S10N06A01N S10N04A16N	
2	1	—	—	—	—	27.7	66.7	—	—	14.7	35.4		
2	1.5	51.9	125	54.5	131	—	—	28.6	68.7	—	—		
2	1.5	—	—	—	—	41.5	100	—	—	22.1	53.1	S10N06A16N S10N04A02N S10N06A02N	
2	2	69.3	167	72.7	175	—	—	38.1	91.7	—	—		
2	2	—	—	—	—	55.4	133	—	—	29.4	70.8		
2	3	103.8	249.9	109.2	262.5	—	—	57.3	137.4	—	—	S10N04A03N S10N06A03N S10N04A05N	
2	3	—	—	—	—	83.1	200	—	—	44.1	106.2		
2	5	173	416	182	437	—	—	95.3	229	—	—		
2	5	—	—	—	—	138	333	—	—	73.6	177	S10N06A05N S10N04A07N S10N06A07N	
2	7.5	260	624	273	656	—	—	143	344	—	—		
2	7.5	—	—	—	—	208	500	—	—	110	266		
Connection Diagram ②		I		I		I		K		K			

① Additional wiring trough may be required.

② Refer to Page 44-17 for Buck-Boost wiring diagrams.

Note: Output voltage for lower input voltage can be found by:  $\frac{\text{Rated Output Voltage}}{\text{Rated Input Voltage}} \times \text{Input Actual Voltage} = \text{Output New Voltage}$ .

Note: Output kVA available at reduced input voltage can be found by:  $\frac{\text{Actual Input Voltage}}{\text{Rated Input Voltage}} \times \text{Output kVA} = \text{New kVA Rating}$ .

Discount Symbol ..... DT-1

**Three-Phase**

**Table 44-26. Three-Phase Wye Connection 208 Volt Output Required, 60 Hz**

**Note: WARNING!** Three-phase autotransformers should never be used to obtain 4-wire output with 3-wire input. 4-wire output requires 4-wire wye input.

Units Required ①	Unit kVA	Input Available Voltage										Style Number	Price U.S. \$
		152		164		173		180		184			
		Output		Output		Output		Output		Output			
		kVA	Amps	kVA	Amps	kVA	Amps	kVA	Amps	kVA	Amps		
3	.05	—	—	—	—	.75	2.08	—	—	—	—	S10N04A81N	
3	.05	.41	1.15	.56	1.56	—	—	.98	2.71	1.12	3.12	S10N06A81N	
3	.10	—	—	—	—	1.50	4.17	—	—	—	—	S10N04A82N	
3	.10	.82	2.29	1.12	3.12	—	—	1.95	5.41	2.25	6.25	S10N06A82N	
3	.15	—	—	—	—	2.25	6.25	—	—	—	—	S10N04A83N	
3	.15	1.24	3.44	1.69	4.69	—	—	2.92	8.12	3.73	9.37	S10N06A83N	
3	.25	—	—	—	—	3.75	10.4	—	—	—	—	S10N04A26N	
3	.25	2.06	5.73	2.81	7.81	—	—	4.87	13.5	5.62	15.6	S10N06A26N	
3	.50	—	—	—	—	7.5	20.8	—	—	—	—	S10N04A51N	
3	.50	4.12	11.5	5.62	15.6	—	—	9.75	27.1	11.2	31.2	S10N06A51N	
3	.75	—	—	—	—	11.2	31.2	—	—	—	—	S10N04A76N	
3	.75	6.19	17.2	8.44	23.4	—	—	14.6	40.6	16.8	46.8	S10N06A76N	
3	1	—	—	—	—	15	41.7	—	—	—	—	S10N04A01N	
3	1	8.25	22.9	11.2	31.2	—	—	19.5	54.1	22.5	62.5	S10N06A01N	
3	1.5	—	—	—	—	22.5	62.5	—	—	—	—	S10N04A16N	
3	1.5	12.4	34.4	16.9	46.9	—	—	29.2	81.2	33.7	93.7	S10N06A16N	
3	2	—	—	—	—	30	83.3	—	—	—	—	S10N04A02N	
3	2	16.5	45.8	22.5	62.5	—	—	39	108	45	125	S10N06A02N	
3	3	—	—	—	—	45	125	—	—	—	—	S10N04A03N	
3	3	24.7	68.7	33.6	93.6	—	—	58.5	162.3	67.5	187.5	S10N06A03N	
3	5	—	—	—	—	75	208	—	—	—	—	S10N04A05N	
3	5	41.2	115	56.2	156	—	—	97.5	271	112	312	S10N06A05N	
3	7.5	—	—	—	—	112	312	—	—	—	—	S10N04A07N	
3	7.5	61.9	172	84.4	234	—	—	146	406	168	468	S10N06A07N	
Connection Diagram ②		P		N		N		O		M			

Units Required ①	Unit kVA	Input Available Voltage										Style Number	Price U.S. \$
		189		229		236		250		264			
		Output		Output		Output		Output		Output			
		kVA	Amps	kVA	Amps	kVA	Amps	kVA	Amps	kVA	Amps		
3	.05	1.5	4.16	1.65	4.58	—	—	.9	2.5	—	—	S10N04A81N	
3	.05	—	—	—	—	1.27	3.54	—	—	.71	1.98	S10N06A81N	
3	.10	3.0	8.33	3.3	9.17	—	—	1.8	5.0	—	—	S10N04A82N	
3	.10	—	—	—	—	2.55	7.08	—	—	1.42	3.95	S10N06A82N	
3	.15	4.5	12.5	4.95	13.7	—	—	2.7	7.5	—	—	S10N04A83N	
3	.15	—	—	—	—	3.82	10.6	—	—	2.14	5.93	S10N06A83N	
3	.25	7.5	20.8	8.25	22.9	—	—	4.5	12.5	—	—	S10N04A26N	
3	.25	—	—	—	—	6.35	17.7	—	—	3.56	9.88	S10N06A26N	
3	.50	15	41.6	16.5	45.8	—	—	9	25	—	—	S10N04A51N	
3	.50	—	—	—	—	12.7	35.4	—	—	7.12	19.3	S10N06A51N	
3	.75	22.5	62.4	24.7	68.7	—	—	13.5	37.5	—	—	S10N04A76N	
3	.75	—	—	—	—	19	53.1	—	—	10.7	29.3	S10N06A76N	
3	1	30	83.3	33	91.7	—	—	18	50	—	—	S10N04A01N	
3	1	—	—	—	—	25.5	70.8	—	—	14.2	39.5	S10N06A01N	
3	1.5	45	125	49.5	137	—	—	27	75	—	—	S10N04A16N	
3	1.5	—	—	—	—	38.2	106	—	—	21.4	59.3	S10N06A16N	
3	2	60	167	66	183	—	—	361	100	—	—	S10N04A02N	
3	2	—	—	—	—	51	142	—	—	28.5	79.2	S10N06A02N	
3	3	90	249.9	99	275.1	—	—	54	150	—	—	S10N04A03N	
3	3	—	—	—	—	76.5	212.4	—	—	46.2	118.5	S10N06A03N	
3	5	150	416	165	458	—	—	90	250	—	—	S10N04A05N	
3	5	—	—	—	—	127	354	—	—	71.2	198	S10N06A05N	
3	7.5	225	624	274	687	—	—	135	375	—	—	S10N04A07N	
3	7.5	—	—	—	—	190	531	—	—	107	293	S10N06A07N	
Connection Diagram ②		M		M		M		N		N			

① Additional wiring trough may be required.

② Refer to Page 44-17 for Buck-Boost wiring diagrams.

**Note:** Output voltage for lower input voltage can be found by:  $\frac{\text{Rated Output Voltage}}{\text{Rated Input Voltage}} \times \text{Input Actual Voltage} = \text{Output New Voltage}$ .

**Note:** Output kVA available at reduced input voltage can be found by:  $\frac{\text{Actual Input Voltage}}{\text{Rated Input Voltage}} \times \text{Output kVA} = \text{New kVA Rating}$ .

Three-Phase

Table 44-27. Three-Phase Wye Connection 230 Volt Output Required, 60 Hz

Note: WARNING! Three-phase autotransformers should never be used to obtain 4-wire output with 3-wire input. 4-wire output requires 4-wire wye input.

Units Required ①	Unit kVA	Input Available Voltage										Style Number	Price U.S. \$
		183		192		199		208		218			
		Output		Output		Output		Output		Output			
		kVA	Amps	kVA	Amps	kVA	Amps	kVA	Amps	kVA	Amps		
3	.05	—	—	.83	2.08	—	—	1.65	4.58	1.66	4.17	S10N04A81N	
3	.05	.62	1.56	—	—	.54	1.35	—	—	—	—	S10N06A81N	
3	.10	—	—	1.66	4.17	—	—	3.3	9.17	3.32	8.35	S10N04A82N	
3	.10	1.25	3.12	—	—	1.08	2.71	—	—	—	—	S10N06A82N	
3	.15	—	—	2.49	6.25	—	—	4.95	13.7	4.98	12.5	S10N04A83N	
3	.15	1.87	4.69	—	—	1.62	4.06	—	—	—	—	S10N06A83N	
3	.25	—	—	4.15	10.4	—	—	8.2	22.9	8.3	20.9	S10N04A26N	
3	.25	3.11	7.81	—	—	2.70	6.77	—	—	—	—	S10N06A26N	
3	.50	—	—	8.3	20.8	—	—	16.5	45.8	16.6	41.7	S10N04A51N	
3	.50	6.22	15.6	—	—	5.39	13.5	—	—	—	—	S10N06A51N	
3	.75	—	—	12.4	31.2	—	—	24.7	68.8	24.9	62.6	S10N04A76N	
3	.75	9.33	23.4	—	—	8.09	20.3	—	—	—	—	S10N06A76N	
3	1	—	—	16.6	41.7	—	—	33	91.7	33.2	83.5	S10N04A01N	
3	1	12.5	31.2	—	—	10.8	27.1	—	—	—	—	S10N06A01N	
3	1.5	—	—	24.9	62.5	—	—	49.5	137	49.8	125	S10N04A16N	
3	1.5	18.7	46.9	—	—	16.2	40.6	—	—	—	—	S10N06A16N	
3	2	—	—	33.2	83.3	—	—	66	183	66.4	167	S10N04A02N	
3	2	24.9	62.5	—	—	21.6	54.2	—	—	—	—	S10N06A02N	
3	3	—	—	49.8	125.1	—	—	99	275	99.6	250.5	S10N04A03N	
3	3	37.5	93.6	—	—	32.4	81.3	—	—	—	—	S10N06A03N	
3	5	—	—	83	208	—	—	165	458	166	417	S10N04A05N	
3	5	62.2	156	—	—	53.9	135	—	—	—	—	S10N06A05N	
3	7.5	—	—	124	312	—	—	247	688	249	626	S10N04A07N	
3	7.5	93.3	234	—	—	80.9	203	—	—	—	—	S10N06A07N	
Connection Diagram ②		N		N		S		M		Q			

Units Required ①	Unit kVA	Input Available Voltage										Style Number	Price U.S. \$
		242		245		253		260		265			
		Output		Output		Output		Output		Output			
		kVA	Amps	kVA	Amps	kVA	Amps	kVA	Amps	kVA	Amps		
3	.05	1.74	4.37	—	—	.91	2.29	—	—	—	—	S10N04A81N	
3	.05	—	—	1.33	3.33	—	—	.70	1.77	—	1.56	S10N06A81N	
3	.10	3.48	8.75	—	—	1.83	4.58	—	—	—	—	S10N04A82N	
3	.10	—	—	2.65	6.67	—	—	1.41	3.54	1.25	3.12	S10N06A82N	
3	.15	5.23	13.1	—	—	2.74	6.87	—	—	—	—	S10N04A83N	
3	.15	—	—	3.98	10.0	—	—	2.12	5.31	1.87	4.69	S10N06A83N	
3	.25	8.71	21.9	—	—	4.56	11.5	—	—	—	—	S10N04A26N	
3	.25	—	—	6.63	16.7	—	—	3.52	8.85	3.11	7.81	S10N06A26N	
3	.50	17.4	43.7	—	—	9.31	22.9	—	—	—	—	S10N04A51N	
3	.50	—	—	13.3	33.3	—	—	7.05	17.7	6.22	15.6	S10N06A51N	
3	.75	26.1	65.6	—	—	13.7	34.4	—	—	—	—	S10N04A76N	
3	.75	—	—	19.9	50	—	—	10.6	26.6	9.33	23.4	S10N06A76N	
3	1	34.8	87.5	—	—	18.3	45.8	—	—	—	—	S10N04A01N	
3	1	—	—	26.5	66.7	—	—	14.1	35.4	12.5	31.2	S10N06A01N	
3	1.5	52.3	131	—	—	27.4	68.7	—	—	—	—	S10N04A16N	
3	1.5	—	—	39.8	100	—	—	21.2	53.1	18.7	46.9	S10N06A16N	
3	2	69.7	175	—	—	36.6	91.6	—	—	—	—	S10N04A02N	
3	2	—	—	53.1	133	—	—	28.2	70.8	24.9	62.5	S10N06A02N	
3	3	104.4	262.5	—	—	54.9	137.4	—	—	—	—	S10N04A03N	
3	3	—	—	79.5	200	—	—	42.3	106.2	37.5	93.6	S10N06A03N	
3	5	174	437	—	—	91.3	229	—	—	—	—	S10N04A05N	
3	5	—	—	133	333	—	—	70.5	177	62.2	156	S10N06A05N	
3	7.5	261	656	—	—	137	344	—	—	—	—	S10N04A07N	
3	7.5	—	—	199	500	—	—	106	266	93.3	234	S10N06A07N	
Connection Diagram ②		Q		Q		R		R		S			

① Additional wiring trough may be required.

② Refer to Page 44-17 for Buck-Boost wiring diagrams.

Note: Output voltage for lower input voltage can be found by:  $\frac{\text{Rated Output Voltage}}{\text{Rated Input Voltage}} \times \text{Input Actual Voltage} = \text{Output New Voltage}$ .

Note: Output kVA available at reduced input voltage can be found by:  $\frac{\text{Actual Input Voltage}}{\text{Rated Input Voltage}} \times \text{Output kVA} = \text{New kVA Rating}$ .

Discount Symbol ..... DT-1

**Three-Phase**

**Table 44-28. Three-Phase Wye Connection 240 Volt Output Required, 60 Hz**

**Note: WARNING!** Three-phase autotransformers should never be used to obtain 4-wire output with 3-wire input. 4-wire output requires 4-wire wye input.

Units Required ①	Unit kVA	Input Available Voltage										Style Number	Price U.S. \$
		190		200		208		218		228			
		Output		Output		Output		Output		Output			
		kVA	Amps	kVA	Amps	kVA	Amps	kVA	Amps	kVA	Amps		
3	.05	—	—	.86	2.08	—	—	.86	2.08	1.73	4.17	S10N04A81N	
3	.05	.65	1.65	—	—	1.27	3.05	—	—	—	—	S10N06A81N	
3	.10	—	—	1.73	4.17	—	—	1.73	4.17	3.46	8.34	S10N04A82N	
3	.10	1.3	3.12	—	—	2.55	6.12	—	—	—	—	S10N06A82N	
3	.15	—	—	2.59	6.25	—	—	2.59	6.25	5.20	12.5	S10N04A83N	
3	.15	1.95	4.69	—	—	3.82	9.16	—	—	—	—	S10N06A83N	
3	.25	—	—	4.32	10.4	—	—	4.32	10.4	8.66	20.9	S10N04A26N	
3	.25	3.25	7.81	—	—	6.3	15.1	—	—	—	—	S10N06A26N	
3	.50	—	—	8.65	20.8	—	—	8.65	20.8	17.3	41.7	S10N04A51N	
3	.50	6.5	15.6	—	—	12.7	30.4	—	—	—	—	S10N06A51N	
3	.75	—	—	13	31.2	—	—	13	31.2	26	62.6	S10N04A76N	
3	.75	9.75	23.4	—	—	19.2	46	—	—	—	—	S10N06A76N	
3	1	—	—	17.3	41.7	—	—	17.3	41.7	34.6	83.4	S10N04A01N	
3	1	13	31.2	—	—	25.5	61.2	—	—	—	—	S10N06A01N	
3	1.5	—	—	25.9	62.5	—	—	25.9	62.5	52	125	S10N04A16N	
3	1.5	19.5	46.9	—	—	38.2	91.6	—	—	—	—	S10N06A16N	
3	2	—	—	34.6	83.3	—	—	34.6	83.3	69.3	167	S10N04A02N	
3	2	26	62.5	—	—	51	122.4	—	—	—	—	S10N06A02N	
3	3	—	—	51.9	125.1	—	—	51.9	125.1	103.8	250.2	S10N04A03N	
3	3	39	93.6	—	—	76.5	183.6	—	—	—	—	S10N06A03N	
3	5	—	—	86.5	208	—	—	86.5	208	173	417	S10N04A05N	
3	5	65	156	—	—	127.2	305.2	—	—	—	—	S10N06A05N	
3	7.5	—	—	130	312	—	—	130	312	260	626	S10N04A07N	
3	7.5	97.5	234	—	—	192	460	—	—	—	—	S10N06A07N	
Connection Diagram ②		N		N		M		R		Q			

Units Required ①	Unit kVA	Input Available Voltage										Style Number	Price U.S. \$
		252		256		264		272		277			
		Output		Output		Output		Output		Output			
		kVA	Amps	kVA	Amps	kVA	Amps	kVA	Amps	kVA	Amps		
3	.05	1.85	4.37	—	—	.95	2.29	—	—	—	—	S10N04A81N	
3	.05	—	—	1.39	3.33	—	—	.74	1.77	—	—	S10N06A81N	
3	.10	3.64	8.75	—	—	1.91	4.58	—	—	.65	1.56	S10N04A82N	
3	.10	—	—	2.77	6.67	—	—	1.47	3.54	1.3	3.12	S10N06A82N	
3	.15	5.46	13.1	—	—	2.86	6.87	—	—	—	—	S10N04A83N	
3	.15	—	—	4.16	10.0	—	—	2.21	5.31	1.95	4.69	S10N06A83N	
3	.25	9.09	21.9	—	—	4.76	11.5	—	—	—	—	S10N04A26N	
3	.25	—	—	6.93	16.7	—	—	3.68	8.85	3.25	7.81	S10N06A26N	
3	.50	18.2	43.7	—	—	9.53	22.9	—	—	—	—	S10N04A51N	
3	.50	—	—	13.9	33.3	—	—	7.36	17.7	6.5	15.6	S10N06A51N	
3	.75	27.3	65.6	—	—	14.3	34.4	—	—	—	—	S10N04A76N	
3	.75	—	—	20.8	50	—	—	11	26.6	9.75	23.4	S10N06A76N	
3	1	36.4	87.5	—	—	19.1	45.8	—	—	—	—	S10N04A01N	
3	1	—	—	27.7	66.7	—	—	14.7	35.4	13	31.2	S10N06A01N	
3	1.5	54.6	131	—	—	28.6	68.7	—	—	—	—	S10N04A16N	
3	1.5	—	—	41.6	100	—	—	22.1	53.1	19.5	46.9	S10N06A16N	
3	2	72.8	175	—	—	38.1	91.7	—	—	—	—	S10N04A02N	
3	2	—	—	55.4	133	—	—	29.5	70.8	26	62.5	S10N06A02N	
3	3	109.2	262.5	—	—	57.3	137.4	—	—	—	—	S10N04A03N	
3	3	—	—	83.1	200	—	—	44.1	106.2	39	93.6	S10N06A03N	
3	5	182	437	—	—	95.3	229	—	—	—	—	S10N04A05N	
3	5	—	—	139	333	—	—	73.6	177	65	156	S10N06A05N	
3	7.5	273	656	—	—	143	344	—	—	—	—	S10N04A07N	
3	7.5	—	—	208	500	—	—	110	266	97.5	234	S10N06A07N	
Connection Diagram ②		Q		Q		R		R		S			

① Additional wiring trough may be required.

② Refer to **Page 44-17** for Buck-Boost wiring diagrams.

**Note:** Output voltage for lower input voltage can be found by:  $\frac{\text{Rated Output Voltage}}{\text{Rated Input Voltage}} \times \text{Input Actual Voltage} = \text{Output New Voltage}$ .

**Note:** Output kVA available at reduced input voltage can be found by:  $\frac{\text{Actual Input Voltage}}{\text{Rated Input Voltage}} \times \text{Output kVA} = \text{New kVA Rating}$ .

Three-Phase

**Table 44-29. Three-Phase Wye Connection 460 Volt Output Required, 60 Hz**

**Note: WARNING!** Three-phase autotransformers should never be used to obtain 4-wire output with 3-wire input. 4-wire output requires 4-wire wye input.

Units Required ①	Unit kVA	Input Available Voltage														Style Number	Price U.S. \$		
		406		418		432		438		424		436		450					
		Output		Output		Output		Output		Output		Output		Output					
		kVA	Amps	kVA	Amps	kVA	Amps	kVA	Amps	kVA	Amps	kVA	Amps	kVA	Amps	kVA	Amps		
3	.05	—	—	1.66	2.08	—	—	3.22	4.04	—	—	2.1	—	—	—	—	—	S10N04A81N	
3	.05	1.25	1.57	—	—	2.49	3.12	—	—	1.3	1.56	—	—	2.6	—	3.13	—	S10N06A81N	
3	.10	—	—	3.31	4.15	—	—	6.62	8.31	—	—	3.5	4.2	—	—	—	—	S10N04A82N	
3	.10	2.49	3.12	—	—	4.97	6.24	—	—	2.6	3.12	—	—	5.2	—	6.25	—	S10N06A82N	
3	.15	—	—	4.97	6.24	—	—	9.94	12.48	—	—	5.2	6.25	—	—	—	—	S10N04A83N	
3	.15	3.73	4.68	—	—	7.46	9.36	—	—	3.9	4.68	—	—	7.8	—	9.38	—	S10N06A83N	
3	.25	—	—	8.28	10.39	—	—	16.6	20.84	—	—	8.7	10.4	—	—	—	—	S10N04A26N	
3	.25	6.22	7.81	—	—	12.4	15.56	—	—	6.5	7.82	—	—	13	—	15.6	—	S10N06A26N	
3	.50	—	—	16.6	20.84	—	—	33.2	41.67	—	—	17.4	20.9	—	—	—	—	S10N04A51N	
3	.50	12.5	15.69	—	—	24.69	31.25	—	—	13	15.6	—	—	26	31.2	26	31.2	S10N06A51N	
3	.75	—	—	24.8	31.12	—	—	49.6	62.25	—	—	26	31.2	—	—	—	—	S10N04A76N	
3	.75	18.7	23.47	—	—	37.3	46.82	—	—	19.5	23.4	—	—	39	46.9	—	—	S10N06A76N	
3	1	—	—	33.1	41.54	—	—	66.2	83.09	—	—	35	42	—	—	—	—	S10N04A01N	
3	1	24.9	31.25	—	—	49.7	62.38	—	—	26	31.2	—	—	52	—	62.5	—	S10N06A01N	
3	1.5	—	—	49.7	62.38	—	—	99.4	124.75	—	—	52	62.5	—	—	—	—	S10N04A16N	
3	1.5	37.3	46.94	—	—	74.6	93.63	—	—	39	46.8	—	—	78	93.8	93.8	—	S10N06A16N	
3	2	—	—	66.3	83.22	—	—	133	166.93	—	—	69	82.9	—	—	—	—	S10N04A02N	
3	2	49.7	62.38	—	—	99.5	124.88	—	—	52	62.5	—	—	104	125	—	—	S10N06A02N	
3	3	—	—	99.3	124.64	—	—	198.6	249.27	—	—	104	125	—	—	—	—	S10N04A03N	
3	3	74.6	93.63	—	—	149	187.01	—	—	78	93.8	—	—	156	—	187.6	—	S10N06A03N	
3	5	—	—	166	208.35	—	—	322	404.16	—	—	174	209.2	—	—	—	—	S10N04A05N	
3	5	125	156.89	—	—	249	312.53	—	—	130	156.3	—	—	260	312.7	260	312.7	S10N06A05N	
3	7.5	—	—	248	311	—	—	496	622	—	—	260	312	—	—	—	—	S10N04A07N	
3	7.5	187	235	—	—	373	468	—	—	195	234	—	—	390	469	—	—	S10N06A07N	
Connection Diagram ②		R		R		Q		Q		R		R		Q					

① Additional wiring trough may be required.

② Refer to Page 44-17 for Buck-Boost wiring diagrams.

**Note:** Output voltage for lower input voltage can be found by:  $\frac{\text{Rated Output Voltage}}{\text{Rated Input Voltage}} \times \text{Input Actual Voltage} = \text{Output New Voltage}$ .

**Note:** Output kVA available at reduced input voltage can be found by:  $\frac{\text{Actual Input Voltage}}{\text{Rated Input Voltage}} \times \text{Output kVA} = \text{New kVA Rating}$ .

**Single-Phase**

**Table 44-30. Single-Phase Required, 60 Hz**

Units Required ①	Unit kVA	Input Available Voltage/Output Voltage												Style Number	Price U.S. \$	
		200/240		230/277		346/380		362/380		378/416		416/457				
		Output		Output		Output		Output		Output		Output				
		kVA	Amps	kVA	Amps	kVA	Amps	kVA	Amps	kVA	Amps	kVA	Amps			
1	.25	1.25	5.2	1.44	5.2	1.98	5.2	3.95	10.4	2.16	5.2	2.38	5.2	S20N08A26N S20N08A51N S20N08A76N		
1	.50	2.50	10.4	2.88	10.4	3.95	10.4	7.90	20.8	4.33	10.4	4.76	10.4			
1	.75	3.75	15.6	4.32	15.6	5.93	15.6	11.9	31.2	6.49	15.6	7.14	15.6			
1	1	5.00	20.8	5.76	20.8	7.90	20.8	15.8	41.6	8.65	20.8	9.52	20.8	S20N08A01N S20N08A16N S20N08A02N		
1	1.5	7.50	31.2	8.64	31.2	11.9	31.2	23.8	62.5	13.0	31.2	14.3	31.2			
1	2	10.00	41.6	11.5	41.6	15.8	41.6	31.6	83.3	17.3	41.6	19.0	41.6			
1	3	15.0	62.5	17.3	62.5	23.8	62.5	47.5	125.0	26.0	62.5	28.6	62.5	S20N08A03N S20N08A05N S20N08A07N		
1	5	25.0	104.0	28.8	104.0	39.5	104.0	79.0	208.0	43.3	104.0	47.6	104.0			
1	7.5	37.5	156.0	43.2	156.0	59.3	156.0	118.6	312.0	64.9	156.0	71.4	156.0			
Connection Diagram ②		B		B		F		E		F		F				

Units Required ①	Unit kVA	Input Available Voltage/Output Voltage												Style Number	Price U.S. \$	
		436/480		458/480		277/230		480/456		504/480		528/480				
		Output		Output		Output		Output		Output		Output				
		kVA	Amps	kVA	Amps	kVA	Amps	kVA	Amps	kVA	Amps	kVA	Amps			
1	.25	2.50	5.2	4.99	10.4	1.44	6.26	5.23	11.4	5.47	11.4	2.75	5.72	S20N08A26N S20N08A51N S20N08A76N		
1	.50	4.99	10.4	9.98	20.8	2.88	12.5	10.4	22.8	10.9	22.8	5.49	11.4			
1	.75	7.49	15.6	15.0	31.2	4.33	18.8	15.7	34.2	16.4	34.2	8.24	17.2			
1	1	9.98	20.8	20.0	41.6	5.76	25.0	20.9	45.6	21.8	45.6	11.0	22.9	S20N08A01N S20N08A16N S20N08A02N		
1	1.5	15.0	31.2	30.0	62.5	8.64	37.6	31.3	68.4	32.8	68.4	16.5	34.3			
1	2	20.0	41.6	40.0	83.3	11.5	50.1	41.8	91.2	43.7	91.2	22.0	45.8			
1	3	30.0	62.5	60.0	125.0	17.3	75.3	62.7	136.0	65.2	136.0	33.0	68.8	S20N08A03N S20N08A05N S20N08A07N		
1	5	49.9	104.0	99.8	208.0	28.8	125.3	104.5	227.0	108.0	227.0	54.9	114.4			
1	7.5	74.9	156.0	149.8	312.0	43.2	187.9	156.8	341.0	163.0	341.0	82.4	171.6			
Connection Diagram ②		F		E		B		E		E		F				

① Additional wiring trough may be required.

② Refer to Page 44-17 for Buck-Boost wiring diagrams.

**Note:** Output voltage for lower input voltage can be found by:  $\frac{\text{Rated Output Voltage}}{\text{Rated Input Voltage}} \times \text{Input Actual Voltage} = \text{Output New Voltage}$ .

**Note:** Output kVA available at reduced input voltage can be found by:  $\frac{\text{Actual Input Voltage}}{\text{Rated Input Voltage}} \times \text{Output kVA} = \text{New kVA Rating}$ .

Three-Phase

Table 44-31. Three-Phase Required, 60 Hz

Unit kVA	Input Available Voltage/Output Voltage										Style Number	Price U.S. \$
	362/380		346/416		430/473		400/480		436/480			
	Output		Output		Output		Output		Output			
	kVA	Amps	kVA	Amps	kVA	Amps	kVA	Amps	kVA	Amps		
.25	6.52	10.4	3.75	5.2	4.26	5.2	4.33	5.2	4.33	5.2	S20N08A26N S20N08A51N S20N08A76N	
.50	13.0	20.8	7.50	10.4	8.52	10.4	8.65	10.4	8.65	10.4		
.75	19.6	31.2	11.2	15.6	12.8	15.6	13.0	15.6	13.0	15.6		
1	26.1	41.6	15.0	20.8	17.0	20.8	17.3	20.8	17.3	20.8	S20N08A01N S20N08A16N S20N08A02N	
1.5	39.1	62.4	22.5	31.2	25.5	31.2	26.0	31.2	26.0	31.2		
2	52.2	83.2	30.0	41.6	34.1	41.6	34.6	41.6	34.6	41.6		
3	78.4	125.0	45.0	62.5	51.2	62.5	52.0	62.5	52.0	62.5	S20N08A03N S20N08A05N S20N08A07N	
5	130.4	208.0	75.1	104.0	85.2	104.0	86.6	104.0	86.6	104.0		
7.5	195.6	312.0	112.6	156.0	127.8	156.0	129.9	156.0	129.9	156.0		
Connection Diagram ①	I		N		K		N		K			
Units Required ②	2		3		2		3		2			

Unit kVA	Input Available Voltage/Output Voltage								Style Number	Price U.S. \$
	460/483		457/380		504/480		528/480			
	Output		Output		Output		Output			
	kVA	Amps	kVA	Amps	kVA	Amps	kVA	Amps		
.25	8.7	10.4	4.12	6.25	9.08	10.9	4.76	5.72	S20N08A26N S20N08A51N S20N08A76N	
.50	17.4	20.8	8.23	12.5	18.2	21.8	9.51	11.4		
.75	26.1	31.2	12.3	18.8	27.2	32.8	14.3	17.2		
1	34.8	41.6	16.5	25.0	36.3	43.7	19.0	22.9	S20N08A01N S20N08A16N S20N08A02N	
1.5	52.2	62.4	24.7	37.5	54.5	65.5	28.5	34.3		
2	69.6	83.2	32.9	50.0	72.6	87.4	38.0	45.8		
3	104.6	125.0	49.5	75.2	109.7	131.3	57.2	68.8	S20N08A03N S20N08A05N S20N08A07N	
5	174.0	208.0	82.3	125.1	181.6	218.4	95.1	114.4		
7.5	261.0	312.0	123.5	187.6	272.4	327.6	142.7	171.6		
Connection Diagram ①	I		N		I		K			
Units Required ②	2		3		2		2			

① Refer to Page 44-17 for Buck-Boost wiring diagrams.

② Additional wiring trough may be required.

**Note:** Output voltage for lower input voltage can be found by:  $\frac{\text{Rated Output Voltage}}{\text{Rated Input Voltage}} \times \text{Input Actual Voltage} = \text{Output New Voltage}$ .

**Note:** Output kVA available at reduced input voltage can be found by:  $\frac{\text{Actual Input Voltage}}{\text{Rated Input Voltage}} \times \text{Output kVA} = \text{New kVA Rating}$ .

**Autotransformer Applications**

**Table 44-32. Three-Phase Open Delta Connection 480 Volt Output Required, 60 Hz**

Units Required ①	Input Available Voltage						Style Number ②	Price U.S.
	600		575		575			
	Output		Output		Output			
	kVA	Amps	kVA	Amps	kVA	Amps		
2	4.3	5.1	—	—	—	—	S20N11S51N	
2	—	—	—	—	4.1	4.9	S60G11S51N	
2	6.5	7.8	—	—	—	—	S20N11S76N	
2	—	—	—	—	6.2	7.4	S60G11S76N	
2	8.6	10.3	—	—	—	—	S20N11S01N	
2	—	—	—	—	8.3	9.9	S60G11S01N	
2	13.0	15.6	—	—	—	—	S20N11S16N	
2	—	—	—	—	12.4	14.9	S60G11S16N	
2	17.2	20.6	—	—	—	—	S20N11S02N	
2	—	—	—	—	16.5	19.8	S60G11S02N	
2	25.8	31	—	—	—	—	S20N11S03N	
2	—	—	—	—	24.8	29.8	S60G11S03N	
2	43.2	51.9	—	—	—	—	S20N11S05N	
2	—	—	—	—	41	49.3	S60G11S05N	
2	65	78.1	—	—	—	—	S20N11S07N	
2	—	—	—	—	62	74.5	S60G11S07N	
2	86	103.4	—	—	—	—	S20N11S10N	
2	—	—	83	99.8	—	—	S60G11S10N	
2	130	156.3	—	—	—	—	S20N11S15N	
2	—	—	124	149.1	—	—	S60N11S15N	
2	216	259.8	—	—	—	—	T20P11S25	
2	—	—	207	248.9	—	—	S60J11S25N	
2	324	389.7	—	—	—	—	T20P11S37	
2	432	519.6	—	—	—	—	T20P11S50	
Connection Diagram ③	I		J		T			

- ① Additional wiring trough may be required.
- ② On transformers supplied with standard taps, taps must be placed at nominal settings.
- ③ Refer to **Page 44-17** for Buck-Boost wiring diagrams.

**Note:** Output voltage for lower input voltage can be found by:  $\frac{\text{Rated Output Voltage}}{\text{Rated Input Voltage}} \times \text{Input Actual Voltage} = \text{Output New Voltage}$ .

**Note:** Output kVA available at reduced input voltage can be found by:  $\frac{\text{Actual Input Voltage}}{\text{Rated Input Voltage}} \times \text{Output kVA} = \text{New kVA Rating}$ .

**Table 44-33. Single-Phase 480 Volt Output Required, 60 Hz**

Units Required ④	Input Available Voltage						Style Number ⑤	Price U.S.
	600		575		575			
	Output		Output		Output			
	kVA	Amps	kVA	Amps	kVA	Amps		
1	2.5	5.2	—	—	—	—	S20N11S51N	
1	—	—	—	—	2.4	5	S60G11S51N	
1	3.7	7.7	—	—	—	—	S20N11S76N	
1	—	—	—	—	3.6	7.5	S60G11S76N	
1	5.0	10.4	—	—	—	—	S20N11S01N	
1	—	—	—	—	4.8	10	S60G11S01N	
1	7.5	15.6	—	—	—	—	S20N11S16N	
1	—	—	—	—	7.2	15	S60G11S16N	
1	10	20.8	—	—	—	—	S20N11S02N	
1	—	—	—	—	9.6	20	S60G11S02N	
1	15	31.2	—	—	—	—	S20N11S03N	
1	—	—	—	—	14.3	29.7	S60G11S03N	
1	25	52	—	—	—	—	S20N11S05N	
1	—	—	—	—	24	50	S60G11S05N	
1	37.5	78.1	—	—	—	—	S20N11S07N	
1	—	—	—	—	36	75	S60G11S07N	
1	50	104.1	—	—	—	—	S20N11S10N	
1	—	—	43	100	—	—	S60G11S10N	
1	75	156.2	—	—	—	—	S20N11S15N	
1	—	—	72	150	—	—	S60N11S15N	
1	125	260.4	—	—	—	—	T20P11S25	
1	—	—	120	250	—	—	S60J11S25N	
1	187	389.6	—	—	—	—	T20P11S37	
1	250	520.8	—	—	—	—	T20P11S50	
Connection Diagram ⑥	E		H		U			

- ④ Additional wiring trough may be required.
  - ⑤ On transformers supplied with standard taps, taps must be placed at nominal settings.
  - ⑥ Refer to **Page 44-17** for Buck-Boost wiring diagrams.
- Note:** Autotransformers can be used only where local electric codes permit and isolation of the two circuits is not required.

## Type MTA

## Type MTA



Type MTA Transformer

## Product Description

- Varnish impregnated core and coil design.
- Suitable for indoor applications.
- Open core and coil design.

## Application Description

Machine Tool and Industrial Control Transformers provide stepped-down voltages to machine tool control devices enabling control circuits to be isolated from all power and lighting circuits. This allows the use of grounded or ungrounded circuits that are independent of the power or lighting grounds; greater safety is afforded the operator. The control transformer line is particularly adaptable on applications where compact construction is demanded.

## Features, Benefits and Functions

- UL recognized component for units rated 1000 VA and below.
- CSA certified for units rated 1000 VA and below.
- 55°C rise, 105°C insulation system.
- 60 Hz operation standard.
- 100% tested to verify product quality.
- Performance equals or exceeds requirements of ANSI/NEMA ST-1.
- Regulation exceeds ANSI/NEMA requirements for all ratings.
- Each unit must pass rigid tests for turns ratio, insulation, continuity, and over potential.
- 50 – 5000 VA ratings.

## Standards and Certifications

## Industry Standards

All Cutler-Hammer dry-type distribution and control transformers by Eaton Corporation are built and tested in accordance with applicable NEMA, ANSI and IEEE Standards.

## Product Specifications

## Frequency

Cutler-Hammer Type MTA control transformers are designed for 60 Hertz operation. Transformers required for other frequencies are available and must be specifically designed.

## Insulation System and Temperature Rise

Industry standards classify insulation systems and rise as shown below:

Table 44-34. Insulation System Classification

Ambient	+ Winding Rise	+ Hot Spot	= Temp. Class
40°C	55°C	10°C	105°C
40°C	80°C	30°C	150°C
40°C	115°C	30°C	185°C
40°C	150°C	30°C	220°C

The design life of transformers having different insulation systems is the same — the lower temperature systems are designed for the same life as the higher temperature systems.

## Series-Multiple Windings

Series-multiple windings consist of 2 similar coils in each winding which can be connected in series or parallel (multiple). Transformers with series-multiple windings are designated with an "X" or "/" between the voltage ratings, such as voltages of "120/240" or "240 X 480." If the series-multiple winding is designated by an "X," the winding can be connected only for a series or parallel. With the "/" designation, a mid-point also becomes available in addition to the series or parallel connection. As an example, a 120 X 240 winding can be connected for either 120 (parallel) or 240 (series), but a 120/240 winding can be connected for 120 (parallel), or 240 (series), or 240 with a 120 mid-point.

The following pages provide listings for most standard transformer ratings and styles.

For other ratings or styles not shown, refer to Eaton.

**Overcurrent Protection Tables**

Overcurrent protection on both the primary and secondary sides of transformers are specified in UL 508 and the National Electrical Code. The maximum acceptable ratings are shown below. Due to high inrush currents present when a transformer is initially energized, it is recommended that the primary fuse be time delay to prevent nuisance trips during startup.

**Table 44-35. Maximum Acceptable Rating of Primary Overcurrent Protection**

Primary Voltage	VA Rating																
	25	50	75	100	150	200	250	300	350	500	750	1000	1500	2000	3000	5000	7000
115	6/10 (1)	1-1/4 (2)	1-8/10 (3-2/10)	2-1/2 (4)	3-1/2 (6-1/4)	5 (8)	4	5	5	8	10	15	20	25	—	—	—
120	6/10 (1)	1-1/4 (2)	1-8/10 (3)	2-1/4 (4)	3-1/2 (6-1/4)	5 (8)	4	5	5	8	10	15	15	20	—	—	—
200	3/10 (6/10)	3/4 (1-1/4)	1-1/8 (1-8/10)	1-1/2 (2-1/2)	2-1/4 (3-1/2)	3 (5)	3-1/2 (6-1/4)	4-1/2 (7-1/2)	5 (8)	4-1/2	7	9	15	15	20	—	—
208	3/10 (6/10)	6/10 (1-1/8)	1 (1-8/10)	1-4/10 (2-1/4)	2 (3-1/2)	2-8/10 (4-1/2)	3-1/2 (6)	4 (7)	5 (8)	4	6	8	12	15	20	30	—
220	3/10 (1/2)	6/10 (1-1/8)	1 (1-6/10)	1-1/4 (2-1/4)	2 (3-2/10)	2-1/2 (4-1/2)	3-2/10 (5-6/10)	4 (6-1/4)	4-1/2 (7-1/2)	4	6	8	12	15	20	30	—
230	3/10 (1/2)	6/10 (1)	8/10 (1-6/10)	1-1/4 (2)	1-8/10 (3-2/10)	2-1/2 (4)	3-2/10 (5)	3-1/2 (6-1/4)	4-1/2 (7-1/2)	4	6	8	10	15	20	30	—
240	3/10 (1/2)	6/10 (1)	8/10 (1-1/2)	1-1/4 (2)	1-8/10 (3)	2-1/4 (4)	3 (5)	3-1/2 (6-1/4)	4 (7)	3-1/2	5	7	10	15	20	30	—
277	1/4 (4/10)	1/2 (8/10)	8/10 (1-1/4)	1 (1-8/10)	1-6/10 (2-1/2)	2 (3-1/2)	2-1/2 (4-1/2)	3-2/10 (5)	3-1/2 (6-1/4)	5 (9)	5	6	9	12	15	25	—
380	3/16 (3/10)	3/10 (6/10)	1/2 (8/10)	3/4 (1-1/4)	1-1/8 (1-8/10)	1-1/2 (2-1/2)	1-8/10 (3-2/10)	2-1/4 (3-1/2)	2-1/2 (4-1/2)	3-1/2 (6-1/4)	5-6/10 (9)	4-1/2	6-1/4	9	15	20	25
400	3/16 (3/10)	3/10 (6/10)	1/2 (8/10)	3/4 (1-1/4)	1-1/8 (1-8/10)	1-1/2 (2-1/2)	1-8/10 (3)	2-1/4 (3-1/2)	2-1/2 (4)	3-1/2 (6-1/4)	5-6/10 (9)	4-1/2	6-1/4	9	12	15	20
416	15/100 (3/10)	3/10 (6/10)	1/2 (8/10)	6/10 (1-1/8)	1 (1-8/10)	1-4/10 (2-1/4)	1-8/10 (3)	2 (3-1/2)	2-1/2 (4)	3-1/2 (6)	5 (9)	4	6	8	12	15	20
440	15/100 (1/4)	3/10 (1/2)	1/2 (8/10)	6/10 (1-1/8)	1 (1-6/10)	1-1/4 (2-1/4)	1-6/10 (2-8/10)	2 (3-2/10)	2-1/4 (3-1/2)	3-2/10 (5)	5 (8)	4	6	8	12	15	20
460	15/100 (1/4)	3/10 (1/2)	4/10 (8/10)	6/10 (1)	8/10 (1-1/2)	1-1/4 (2)	1-6/10 (2-1/2)	1-8/10 (3-2/10)	2-1/4 (3-2/10)	3-2/10 (5)	4-1/2 (8)	3-1/2	6	8	12	15	20
480	15/100 (1/4)	3/10 (1/2)	4/10 (3/4)	6/10 (1)	8/10 (1-1/2)	1-1/4 (2)	1-1/2 (2-1/2)	1-8/10 (3)	2 (3-1/2)	3 (5)	4-1/2 (7-1/2)	3-1/2	5	7	10	15	20
550	1/8 (2/10)	1/4 (4/10)	4/10 (6/10)	1/2 (8/10)	8/10 (1-1/4)	1 (1-8/10)	1-1/4 (2-1/4)	1-6/10 (2-1/2)	1-8/10 (3)	2-1/2 (4-1/2)	4 (6-1/4)	5	4-1/2	6	9	15	15
575	1/8 (2/10)	1/4 (4/10)	3/10 (6/10)	1/2 (8/10)	3/4 (1-1/4)	1 (1-6/10)	1-1/4 (2)	1-1/2 (2-1/2)	1-8/10 (3)	2-1/2 (4)	3 (6-1/4)	5	4-1/2	6	9	15	15
600	1/8 (2/10)	2/10 (4/10)	3/10 (6/10)	1/2 (8/10)	3/4 (1-1/4)	8/10 (1-6/10)	1-1/4 (2)	1-1/2 (2-1/2)	1-6/10 (2-8/10)	2-1/4 (4)	3-1/2 (6-1/4)	5	4	6	9	15	15

**Note:** If the rated primary current is less than 2 amperes, the maximum rating of the overcurrent device is 300% for power circuits, shown above, or 500% for control circuits, shown above (in brackets). If the rated primary current is 2 amperes or more, the maximum rating of the overcurrent device is 250%. All figures assume secondary overcurrent protection per NEC/UL. References: NEC 430-72 (c) exception 2, 450-3 (b) 1 & 2, UL 508 32.7, UL 845 11.16 and 11.17.

**Table 44-36. Maximum Acceptable Rating of Secondary Overcurrent Protection**

Secondary Voltage	VA Rating															
	25	50	75	100	150	200	250	300	350	500	750	1000	1500	2000	3000	5000
12	3-1/2	7	10	15	20	30	—	—	—	—	—	—	—	—	—	—
24	1-6/10	3-2/10	5	6-1/4	10	12	15	20	20	30	—	—	—	—	—	—
90	4/10	8/10	1-1/4	1-8/10	2-1/2	3-1/2	4-1/2	5	6-1/4	9	12	15	30	30	—	—
95	4/10	8/10	1-1/4	1-6/10	2-1/2	3-1/2	4	5	6	8	12	15	20	30	—	—
100	4/10	8/10	1-1/4	1-6/10	2-1/2	3-2/10	4	5	5-6/10	8	12	15	20	30	—	—
110	3/10	3/4	1-1/8	1-1/2	2-1/4	3	3-1/2	4-1/2	5	7-1/2	10	15	20	30	—	—
115	3/10	6/10	1	1-4/10	2	2-8/10	3-1/2	4	5	7	10	15	20	30	—	—
120	3/10	6/10	1	1-1/4	2	2-1/2	3-2/10	4	4-1/2	6-1/4	10	15	20	20	—	—
220	15/100	3/10	1/2	3/4	1-1/8	1-1/2	1-8/10	2-1/4	2-1/2	3-1/2	5-6/10	7	9	15	20	30
230	15/100	3/10	1/2	6/10	1	1-4/10	1-8/10	2	2-1/2	3-1/2	5	7	8	15	20	30
240	15/100	3/10	1/2	6/10	1	1-1/4	1-6/10	2	2-1/2	3-2/10	5	7	8	12	20	30

**Note:** If the rated secondary current is less than 9 amperes, the maximum rating of the overcurrent device is 167%; 9 amperes or more, the maximum rating of the overcurrent device is 125%. If 125% does not correspond to a standard fuse rating, the next highest standard rating may be used. References: NEC 430-72 (c) exception 2, 450-3 (b) 1 & 2, UL 508 32.7, UL 845 11.16 and 11.17.

Wiring Diagrams

Type MTA and MTC Control Transformers

Table 44-37. Wiring for Diagram 1

Volts		Connect	Lines
A	B		
460	—	H2 to H3	H1-H4
230	—	H1 to H3 and H2 to H4	H1-H4
115	—	—	X1-X2

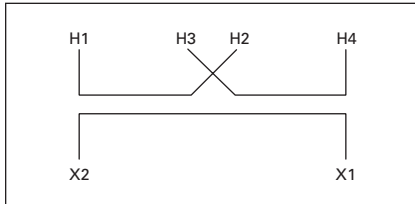

Figure 44-2. Diagram 1

Table 44-38. Wiring for Diagram 2

Volts		Connect	Lines
A	B		
575	416	H2 to H3	H1-H5
460	380	H2 to H3	H1-H4
230	—	H1 to H3 and H2 to H4	H1-H4
—	208	H1 to H3 and H2 to H5	H1-H5
115	115	—	X1-X3
95	95	—	X1-X2

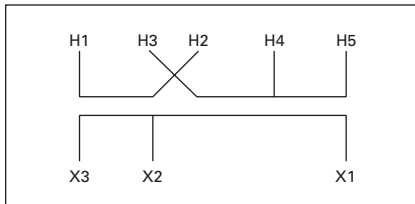

Figure 44-3. Diagram 2

Table 44-39. Wiring for Diagram 3

Volts		Connect	Lines
A	B		
460	—	H2 to H3	H1-H4
230	—	H1 to H3 and H2 to H4	H1-H4
230	—	X2 to X3	X1-X4
115	—	X1 to X3 and X2 to X4	X1-X4

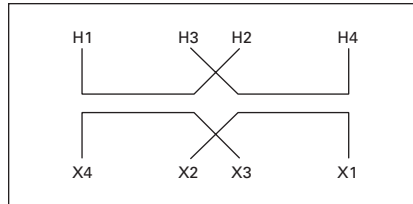

Figure 44-4. Diagram 3

Table 44-40. Wiring for Diagram 4

Volts		Connect	Lines
A	B		
115	115	—	H1-H2
12	24	—	X1-X2

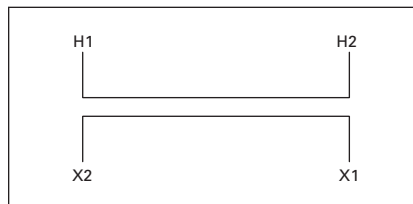

Figure 44-5. Diagram 4

Type AP Control Transformers

Table 44-41. Wiring for Diagram 5

Volts		Connect	Lines
A	B		
480	—	H2 to H3	H1-H4
240	—	H1 to H3 and H2 to H4	H1-H4
240	—	X2 to X3	X1-X4
115	—	X1 to X3 and X2 to X4	X1-X4

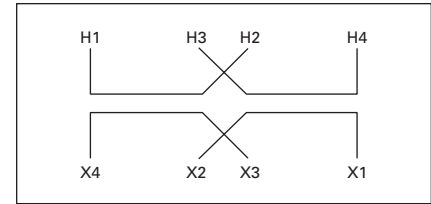

Figure 44-6. Diagram 5

**Type MTA**

**Product Selection**

Additional Product Selection information begins on **Page 44-63**.

**Table 44-42. Type MTA**

VA	Dimensions (Inches)			Weight Lbs.	Dimensions (mm)			Weight kg	Frame	Wiring Diagram ①	Style Number	Price U.S.
	Height	Width	Depth		Height	Width	Depth					
<b>230/460 Volts to 115 Volts, 60 Hz</b>												
50	(Use Type MTC – C0050C2A)											
75	3-3/16	3-3/4	3-3/4	3	80	95	95	1.4	FR1510	1	C0075A2F	
100	3-3/16	3-3/4	4	4	80	95	102	1.8	FR1512	1	C0100A2F	
150	3-3/16	3-3/4	4-3/4	6	80	95	95	2.7	FR1520	1	C0150A2F	
200	3-13/16	4-1/2	4-1/2	7	96	114	114	3.2	FR1714	1	C0200A2F	
250	3-13/16	4-1/2	5	8	96	114	127	3.6	FR1717	1	C0250A2F	
300	3-13/16	4-1/2	6	12	96	114	152	5.4	FR1730	1	C0300A2F	
350	3-13/16	4-1/2	6	12	96	114	152	5.4	FR1727	1	C0350A2F	
500	4-3/8	5-1/4	5-5/8	15	111	133	143	6.8	FR1923	1	C0500A2F	
750	4-3/8	5-1/4	6-1/8	19	111	133	155	8.6	FR1931	1	C0750A2F	
1000	5-1/4	6-1/8	6-3/4	19	133	155	171	8.6	FRC613	1	C1000A2F	
1500	6	6-7/8	7-1/2	27	152	174	190	12.3	FRC614	1	C1500A2F	
2000	5-7/8	6-7/8	8-1/2	36	149	174	215	16.3	FRC827	1	C2000A2F	
3000	6-1/2	8-3/16	8-3/4	52	165	207	222	23.6	FRC828	1	C3000A2F	
5000	7-5/8	8-15/16	10-1/4	79	193	227	260	35.8	FRC829	1	C5000A2F	
<b>230/460 Volts to 115/230 Volts, 60 Hz</b>												
50	2-19/32	3	3-1/4	2	65	76	82	.9	FR1310	3	C0050A2G	
75	3-3/16	3-3/4	3-3/4	3	80	95	95	1.4	FR1510	3	C0075A2G	
100	3-3/16	3-3/4	4	4	80	95	102	1.8	FR1512	3	C0100A2G	
150	3-3/16	3-3/4	4-3/4	6	80	95	95	2.7	FR1520	3	C0150A2G	
200	3-13/16	4-1/2	4-1/2	7	96	114	114	3.2	FR1714	3	C0200A2G	
250	3-13/16	4-1/2	5	8	96	114	127	3.6	FR1717	3	C0250A2G	
300	3-13/16	4-1/2	6	10	96	114	152	4.5	FR1727	3	C0300A2G	
350	3-13/16	4-1/2	6	12	96	114	152	5.4	FR1727	3	C0350A2G	
500	4-3/8	5-1/4	6-1/4	15	111	133	158	6.8	FR1930	3	C0500A2G	
750	5-1/4	6-1/8	6-3/4	19	133	155	171	8.6	FRC613	3	C0750A2G	
1000	5-1/4	6-1/8	6-3/4	19	133	155	171	8.6	FRC613	3	C1000A2G	
1500	6	6-7/8	7-1/2	27	152	174	190	12.3	FRC614	3	C1500A2G	
2000	5-7/8	6-7/8	8-1/2	36	149	174	215	16.3	FRC827	3	C2000A2G	
3000	6-1/2	8-3/16	8-3/4	52	165	207	222	23.6	FRC828	3	C3000A2G	
5000	5-5/8	8-15/16	10-1/4	79	193	227	260	35.8	FRC829	3	C5000A2G	

① See **Page 44-34** for Wiring Diagrams.

**Note:** For additional information, refer to the Cutler-Hammer Industrial Control Transformer Binder B1228A.

For other ratings or styles not shown, refer to Eaton.

Discount Symbol ..... DT-1

Type MTA

Table 44-43. Type MTA

VA	Dimensions (Inches)			Weight Lbs.	Dimensions (mm)			Weight kg	Frame	Wiring Diagram ①	Style Number	Price U.S.
	Height	Width	Depth		Height	Width	Depth					
<b>230/460/575 Volts to 115/95 Volts, 50/60 Hz</b>												
50	2-19/32	3	3-3/4	2	98	76	95	1.5	FR1314	2A	C0050A3C	
75	3-3/16	3-3/4	4	4	80	95	102	1.8	FR1512	2A	C0075A3C	
100	3-3/16	3-3/4	4 3/4	5	80	95	120	2.7	FR1517	2A	C0100A3C	
150	3-13/16	4-1/2	4-1/2	7	96	114	114	3.2	FR1714	2A	C0150A3C	
200	3-13/16	4-1/2	5	8	96	114	127	3.6	FR1717	2A	C0200A3C	
250	3-13/16	4-1/2	5-1/2	10	96	114	139	4.5	FR1723	2A	C0250A3C	
300	3-13/16	4-1/2	6	12	96	114	152	5.4	FR1730	2A	C0300A3C	
350	4-3/8	5-1/4	5-5/8	14	111	133	143	6.8	FR1923	2A	C0350A3C	
500	4-3/8	5-1/4	6-1/8	17	111	133	155	8.6	FR1931	2A	C0500A3C	
750	4-3/8	5-1/4	7-3/4	27	111	133	196	12.3	FR1943	2A	C0750A3C	
1000	6	6-7/8	7-1/2	24	152	174	190	10.9	FRC614	2A	C1000A3C	
1500	5-7/8	6-7/8	8-1/2	34	149	174	215	15.4	FRC827	2A	C1500A3C	
<b>115 Volts to 24 Volts, 50/60 Hz</b>												
50	2-19/32	3	3-3/4	2	65	76	82	.9	FR1310	4B	C0050A3B	
100	3-3/16	3-3/4	4-1/8	5	80	95	104	2.3	FR1513	4B	C0100A3B	
200	3-13/16	4-1/2	4-1/2	7	96	114	114	3.2	FR1714	4B	C0200A3B	
<b>208/380/416 Volts to 115/95 Volts, 50/60 Hz</b>												
50	2-19/32	3	3-3/4	3	98	76	95	1.5	FR1314	2B	C0050A3D	
100	3-3/16	3-3/4	4-3/4	5	80	95	120	2.3	FR1516	2B	C0100A3D	
150	3-13/16	4-1/2	4-1/2	7	96	114	114	3.2	FR1714	2B	C0150A3D	
200	3-13/16	4-1/2	5	8	96	114	127	3.6	FR1717	2B	C0200A3D	
250	3-13/16	4-1/2	5-1/2	10	96	114	139	4.5	FR1723	2B	C0250A3D	
300	3-13/16	4-1/2	6	13	96	114	152	5.4	FR1730	2B	C0300A3D	
500	4-3/8	5-1/4	6-1/8	18	111	133	155	8.6	FR1931	2B	C0500A3D	
750	4-3/8	5-1/4	7-3/4	27	111	133	196	12.3	FR1943	2B	C0750A3D	
1000	6	6-7/8	7-1/2	25	152	174	190	10.9	FRC614	2B	C1000A3D	
1500	5-7/8	6-7/8	8-1/2	33	149	174	215	15.4	FRC827	2B	C1500A3D	

① See Page 44-34 for Wiring Diagrams.

Note: For additional information, refer to the Cutler-Hammer Industrial Control Transformer Binder B1228A.

For other ratings or styles not shown, refer to Eaton.

Discount Symbol ..... DT-1

**Type MTC**

**Type MTC**



*Type MTC Transformers*

**Product Description**

- Varnish impregnated core and coil design.
- Suitable for indoor applications.

**Application Description**

Transformers provide stepped down voltages to machine tool control devices enabling control circuits to be isolated from all power and lighting circuits. This allows the use of grounded or ungrounded circuits that are independent of the power or lighting grounds; greater safety is afforded the operator. The control transformer line is particularly adaptable on applications where compact construction is demanded. The MTC line is similar to the MTA line except it provides increased regulation.

**Features, Benefits and Functions**

- Designed specifically for loads requiring extremely good regulation — 10% – 200% better regulation than Type MTA.
- UL recognized component for units rated 1000 VA and below.
- CSA certified for units rated 1000 VA and below.
- 50/60 Hz operation standard.
- 100% tested to verify product quality.
- Each unit must pass rigid tests for turns ratio, insulation, continuity, and over potential.
- Performance equals or exceeds requirements of ANSI/NEMA ST-1.
- Regulation exceeds ANSI/NEMA requirements for all ratings.
- 50 – 5000 VA ratings.
- 55°C rise, 105°C insulation system.

**Standards and Certifications**

**Industry Standards**

All Cutler-Hammer dry-type distribution and control transformers by Eaton Corporation are built and tested in accordance with applicable NEMA, ANSI and IEEE Standards.

**Product Specifications**

**Frequency**

Cutler-Hammer standard dry-type distribution transformers are designed for 60 Hz operation. Transformers required for other frequencies are available and must be specifically designed.

**Insulation System and Temperature Rise**

Industry standards classify insulation systems and rise as shown below:

**Table 44-44. Insulation System Classification**

Ambient	+ Winding Rise	+ Hot Spot	= Temp. Class
40°C	55°C	10°C	105°C
40°C	80°C	30°C	150°C
40°C	115°C	30°C	185°C
40°C	150°C	30°C	220°C

The design life of transformers having different insulation systems is the same — the lower temperature systems are designed for the same life as the higher temperature systems.

**Series-Multiple Windings**

Series-multiple windings consist of 2 similar coils in each winding which can be connected in series or parallel (multiple). Transformers with series-multiple windings are designated with an "X" or "/" between the voltage ratings, such as voltages of "120/240" or "240 X 480." If the series-multiple winding is designated by an "X," the winding can be connected only for a series or parallel. With the "/" designation, a mid-point also becomes available in addition to the series or parallel connection. As an example, a 120 X 240 winding can be connected for either 120 (parallel) or 240 (series), but a 120/240 winding can be connected for 120 (parallel), or 240 (series), or 240 with a 120 mid-point.

The following pages provide listings for most standard transformer ratings and styles.  
 For other ratings or styles not shown, refer to Eaton.

Type MTC

Product Selection

Additional Product Selection information begins on Page 44-63.

Table 44-45. Type MTC

VA	Dimensions (Inches)			Weight Lbs.	Dimensions (mm)			Weight kg	Frame	Wiring Diagram ①	Style Number	Price U.S.
	Height	Width	Depth		Height	Width	Depth					
240/480 Volts to 120 Volts, 60 Hz												
230/460 Volts to 115 Volts, 50/60 Hz												
220/440 Volts to 110 Volts, 50/60 Hz												
50	2-19/32	3	3-3/4	2	66	76	95	.9	FR1310	1	C0050C2A	
75	2-19/32	3	3-3/4	3	66	76	95	1.4	FR1314	1	C0075C2A	
100	2-7/8	3-3/8	4	3	73	86	102	1.4	FR1413	1	C0100C2A	
150	3-3/16	3-3/4	4-3/4	6	81	95	121	2.7	FR1517	1	C0150C2A	
200	3-13/16	4-1/2	4-1/2	7	97	114	114	3.2	FR1714	1	C0200C2A	
250	3-13/16	4-1/2	5	8	97	114	127	3.6	FR1717	1	C0250C2A	
300	3-13/16	4-1/2	5-3/8	10	97	114	137	4.5	FR1722	1	C0300C2A	
350	3-13/16	4-1/2	6	11	97	114	152	5.0	FR1726	1	C0350C2A	
500	4-3/8	5-1/4	6-1/8	20	111	133	156	9.1	FR1931	1	C0500C2A	
750	4-3/8	5-1/4	7-3/4	28	111	133	197	12.7	FR1934	1	C0750C2A	
1000	5-7/16	6-3/8	7-1/2	34	138	162	191	15.4	FR2236	1	C1000C2A	
1500	6-1/8	6-7/8	8-3/8	35	156	175	213	15.9	FRC822	1	C1500C2A	
2000	6	6-3/4	8-1/2	38	152	171	216	17.3	FRC823	1	C2000C2A	
3000	7-3/8	8-7/16	8-3/4	53	187	214	222	24.1	FRC824	1	C3000C2A	
5000	7-7/8	8-11/16	11	82	200	221	279	37.2	FRC825	1	C5000C2A	

① See Page 44-34 for Wiring Diagrams.

Note: For additional information, refer to the Cutler-Hammer Industrial Control Transformer Binder B1228A.

Table 44-46. Type MTC with Integrally Mounted 30 Amperes, 600 volt Class with 2-Pole Primary Fuse Block for Rejection Type Fuses (Fuses Not Included)

VA	Dimensions (Inches)			Weight Lbs.	Dimensions (mm)			Weight kg	Frame	Wiring Diagram ②	Style Number	Price U.S.
	Height	Width	Depth		Height	Width	Depth					
240/480 Volts to 120 Volts, 60 Hz												
230/460 Volts to 115 Volts, 50/60 Hz												
220/440 Volts to 110 Volts, 50/60 Hz												
50	3-7/8	3	3-3/4	2.2	98	76	83	1.0	FR1310	1	C0050C2AFB	
75	3-7/8	3	3-3/4	3.2	98	76	95	1.5	FR1314	1	C0075C2AFB	
100	4-5/32	3-3/8	4	3.2	106	86	102	1.5	FR1413	1	C0100C2AFB	
150	4-15/32	3-3/4	4-3/4	6.2	114	95	121	2.8	FR1517	1	C0150C2AFB	
200	5-3/32	4-1/2	4-1/2	7.2	129	114	114	3.3	FR1714	1	C0200C2AFB	
250	5-3/32	4-1/2	5	8.2	129	114	127	3.7	FR1717	1	C0250C2AFB	
300	5-3/32	4-1/2	5-3/8	10.2	129	114	137	4.7	FR1722	1	C0300C2AFB	
350	5-3/32	4-1/2	6	11.2	129	114	152	5.1	FR1726	1	C0350C2AFB	
500	5-21/32	5-1/4	6-1/8	20.2	144	133	156	9.2	FR1931	1	C0500C2AFB	
750	5-21/32	5-1/4	7-3/4	28.2	144	133	197	12.8	FR1934	1	C0750C2AFB	
1000	6-23/32	6-3/8	7-1/2	34.2	171	162	191	15.5	FR2236	1	C1000C2AFB	
1500	7-13/32	6-7/8	8-3/8	35.2	188	175	213	16.0	FRC822	1	C1500C2AFB	
2000	7-9/32	6-3/4	8-1/2	38.2	185	171	216	17.4	FRC823	1	C2000C2AFB	

② See Page 44-34 for Wiring Diagrams.

Note: For additional information, refer to the Cutler-Hammer Industrial Control Transformer Binder B1228A.

**Type MTE**

**Type MTE**



*Type MTE Transformers*

**Product Description**

- Epoxy-encapsulated coils.

**Application Description**

Transformers provide stepped down voltages to machine tool control devices enabling control circuits to be isolated from all power and lighting circuits. This allows the use of grounded or ungrounded circuits that are independent of the power or lighting grounds; greater safety is afforded the operator. The control transformer line is particularly adaptable on applications where compact construction is demanded.

**Note:** The MTG, "open core-coil design" has been superseded by the epoxy-encapsulated core-coil design MTE with no change to dimensions or functionality.

**Features, Benefits and Functions**

- UL listed.
- CSA certified.
- Epoxy encapsulated.
- Laminations of high quality silicon steel to minimize core losses and optimize performance.
- Copper magnet wire for high quality, efficient operation.
- Secondary fuse clips where applicable.
- Optional primary fusing.
- Molded in terminals.
- 50/60 Hz operation.
- 55°C rise, 105°C insulation system.
- Performance meets/exceeds requirements of ANSI/NEMA ST-1.
- Regulation exceeds ANSI/NEMA requirements for all ratings.
- 25 – 1500 VA ratings.
- Molded-in terminals for maximum durability.

**Standards and Certifications**

**Industry Standards**

All Cutler-Hammer dry-type distribution and control transformers by Eaton Corporation are built and tested in accordance with applicable NEMA, ANSI, and IEEE Standards. All 600 volt class transformers are UL listed unless otherwise noted.

**Options and Accessories**

**Primary Fuse Kit**

The primary fuse kit includes a 2-pole class CC fuse block, instructions, and all associated mounting and wiring hardware. Fuses are not included. When installed, the primary fuse kit will add a maximum of 11/16 inch to the transformer depth and 1-15/16 inches to the transformer height.

**Table 44-47. Primary Fuse Kit**

Description	Catalog Number	Price U.S. \$
Primary Fuse Kit	PFK1	

**Note:** 1000 VA and larger are Class 130°C Insulation System.

**Finger-Safe Terminal Covers (Optional)**

- Fits CE marked designs 50 – 750 VA.
- Fits MTE designs 25 – 750 VA.

**Table 44-48. Finger-Safe Terminal Covers**

Description	Catalog Number	Price U.S. \$
4 Terminal Transformers	FSK4	
6 Terminal Transformers	FSK6	

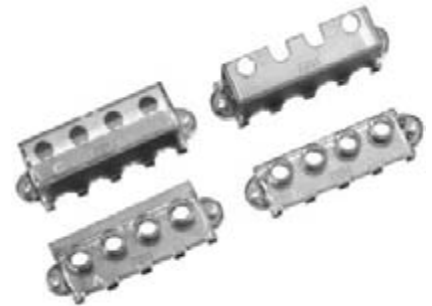

*Finger-Safe Terminal Covers — FSK4*



*Finger-Safe Terminal Covers — FSK6*

**Finger-Safe Primary Fuse Block Covers**

- Fits 2-pole primary fuse blocks on MTE designs.

**Table 44-49. Finger-Safe Primary Fuse Block Covers**

Description	Catalog Number	Price U.S. \$
Primary Fuse Block Covers	FSKFB	



*Finger-Safe Primary Fuse Block Covers*

Type MTE

Product Specifications

Insulation System and Temperature Rise

Industry standards classify insulation systems and rise as shown below:

Table 44-50. Insulation System Classification

Ambient	+ Winding Rise	+ Hot Spot	= Temp. Class
40°C	55°C	10°C	105°C
40°C	80°C	30°C	150°C
40°C	115°C	30°C	185°C
40°C	150°C	30°C	220°C

The design life of transformers having different insulation systems is the same — the lower temperature systems are designed for the same life as the higher temperature systems.

Series-Multiple Windings

Series-multiple windings consist of 2 similar coils in each winding which can be connected in series or parallel (multiple). Transformers with series-multiple windings are designated with an "X" or "/" between the voltage ratings, such as voltages of "120/240" or "240 X 480." If the series-multiple winding is designated by an "X," the winding can be connected only for a series or parallel. With the "/" designation, a mid-point also becomes available in addition to the series or parallel connection. As an example, a 120 X 240 winding can be connected for either 120 (parallel) or 240 (series), but a 120/240 winding can be connected for 120 (parallel), or 240 (series), or 240 with a 120 mid-point.

Wiring Diagrams

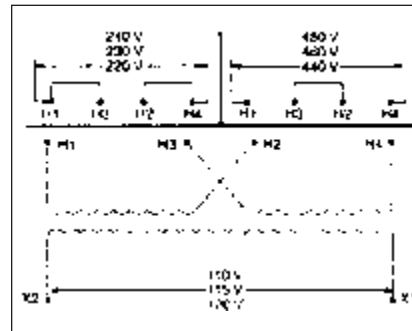

Figure 44-7. Diagram 1

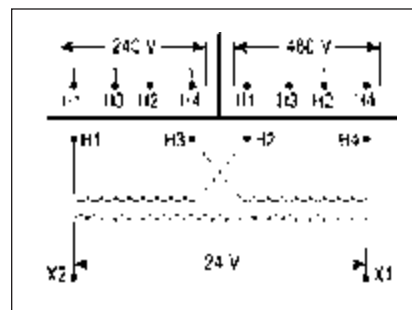

Figure 44-8. Diagram 2

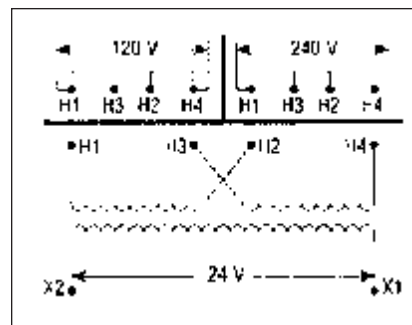

Figure 44-9. Diagram 3

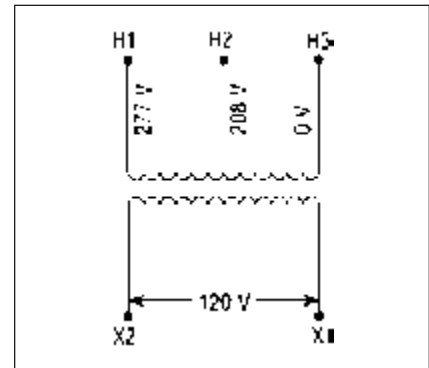

Figure 44-10. Diagram 4

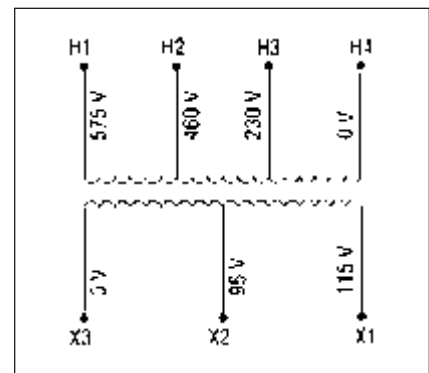

Figure 44-11. Diagram 5

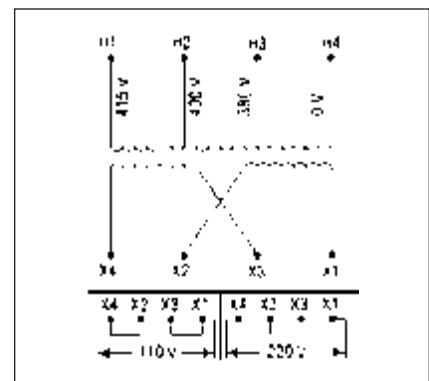

Figure 44-12. Diagram 6

**Wiring Diagrams**

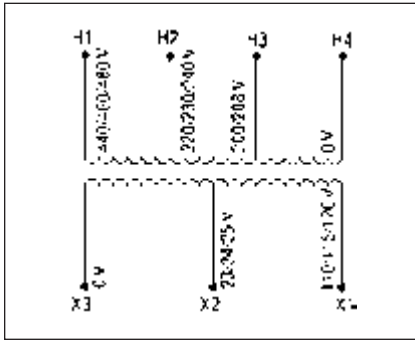

Figure 44-13. Diagram 7

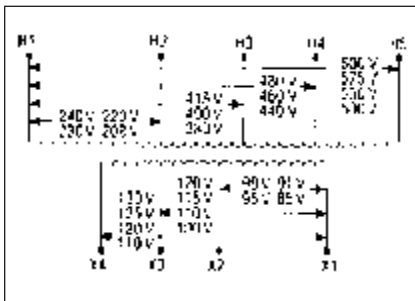

Figure 44-14. Diagram 8

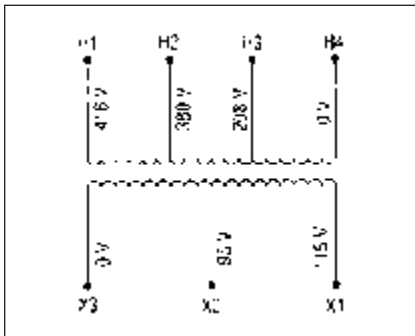

Figure 44-15. Diagram 9

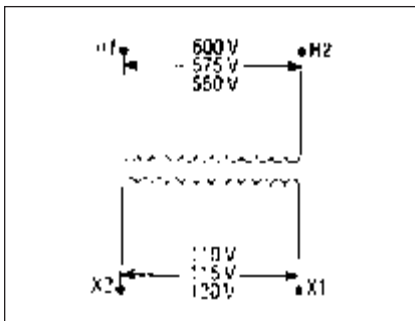

Figure 44-16. Diagram 10

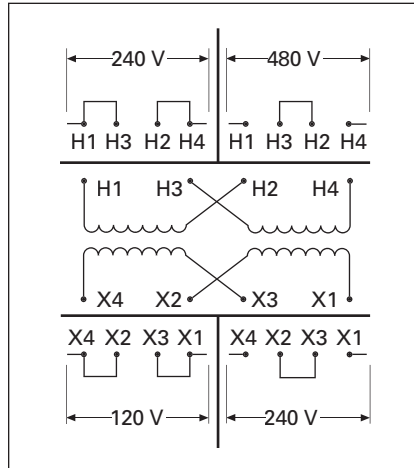

Figure 44-17. Diagram 11

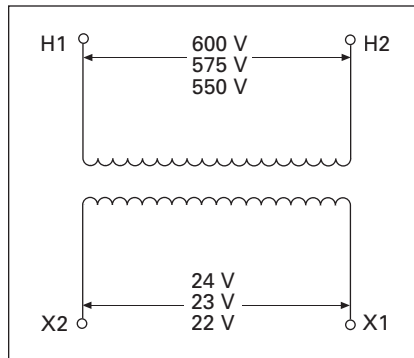

Figure 44-18. Diagram 12

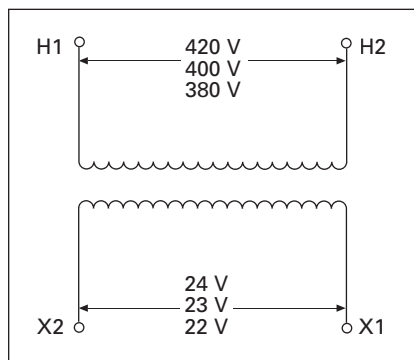

Figure 44-19. Diagram 13

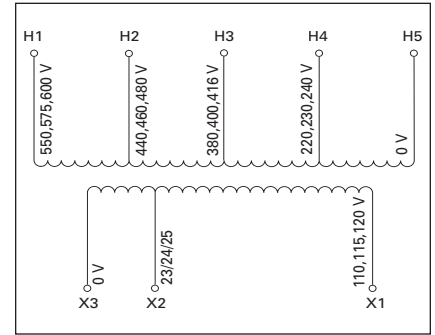

Figure 44-20. Diagram 14

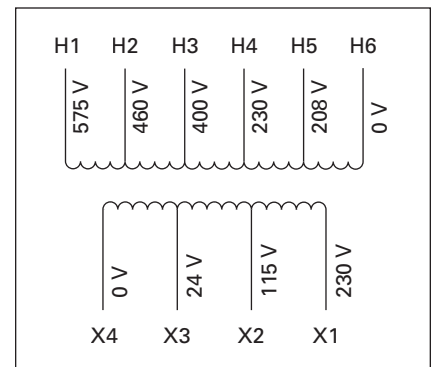

Figure 44-21. Diagram 15

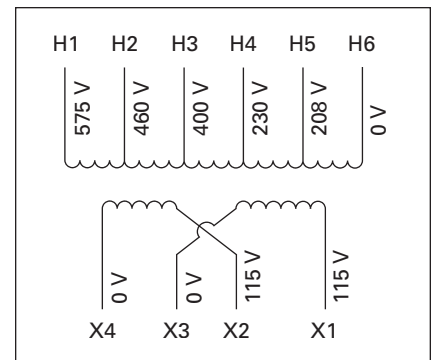

Figure 44-22. Diagram 16

Type MTE

Product Selection

Additional Product Selection information begins on Page 44-63.

Table 44-51. Type MTE — Product Selection

VA	Dimensions (Inches)			Weight Lbs.	Dimensions (mm)			Weight kg	Wiring Diagram ①	Style Number	Price U.S. \$
	Height	Width	Depth		Height	Width	Depth				

Primary: 240 x 480, 230 x 460, 220 x 440 with Jumpers

Secondary: 120/115/110 with Fuse Clips for 13/32 x 1-1/2 Fuses

25	2-9/16	3	2-1/2	1.7	65	76	64	.8	1	C0025E2A	
50	2-9/16	3	3	2.6	65	76	76	1.2	1	C0050E2A	
75	2-9/16	3	3-1/2	3.5	65	76	89	1.6	1	C0075E2A	
100	2-7/8	3-3/8	3-3/8	4.2	73	86	86	1.9	1	C0100E2A	
150	3-3/16	3-3/4	4	6.7	81	95	102	3.0	1	C0150E2A	
200	3-13/16	4-1/2	4	8.5	97	114	102	3.9	1	C0200E2A	
250	3-13/16	4-1/2	4-3/8	10.0	97	114	111	4.5	1	C0250E2A	
300	3-13/16	4-1/2	4-3/4	11.3	97	114	121	5.1	1	C0300E2A	
350	3-13/16	4-1/2	5-1/4	13.6	97	114	133	6.2	1	C0350E2A	
500	4-3/4	5-1/4	5-1/2	19.2	121	133	140	8.7	1	C0500E2A	
750	4-3/4	5-1/4	7	28.1	121	133	178	12.8	1	C0750E2A	
1000	5-11/16	6-3/4	6-7/16	29.5	144	171	164	13.4	1	C1000E2A	
1500	6-3/8	7-1/2	7-3/8	40.0	162	191	187	18.1	1	C1500E2A	

Primary: 240 x 480 with Jumpers

Secondary: 24 with Fuse Clips for 13/32 x 1-1/2 Fuses (through 500 VA)

50	2-9/16	3	3	2.7	65	76	76	1.2	2	C0050E2B	
75	2-9/16	3	3-1/2	3.5	65	76	89	1.6	2	C0075E2B	
100	2-7/8	3-3/8	3-3/8	4.2	73	86	86	1.9	2	C0100E2B	
150	3-3/16	3-3/4	4	6.7	81	95	102	3.0	2	C0150E2B	
200	3-13/16	4-1/2	4	8.5	97	114	102	3.9	2	C0200E2B	
250	3-13/16	4-1/2	4-3/8	10.1	97	114	111	4.6	2	C0250E2B	
300	3-13/16	4-1/2	4-3/4	11.4	97	114	121	5.2	2	C0300E2B	
350	3-13/16	4-1/2	5-1/4	13.4	97	114	133	6.1	2	C0350E2B	
500	4-3/4	5-1/4	5-5/8	17.5	121	133	143	7.9	2	C0500E2B	
750	4-3/4	5-1/4	7	28.1	121	133	178	12.8	2	C0750E2B	

Primary: 120 x 240 with Jumpers

Secondary: 24 with Fuse Clips for 13/32 x 1-1/2 Fuses

50	2-9/16	3	3	2.6	65	76	76	1.2	3	C0050E1B	
75	2-9/16	3	3-1/2	3.6	65	76	89	1.6	3	C0075E1B	
100	2-7/8	3-3/8	3-3/8	4.4	73	86	56	2.0	3	C0100E1B	
150	3-3/16	3-3/4	4	6.7	81	95	102	3.0	3	C0150E1B	
200	3-13/16	4-1/2	4	8.3	97	114	102	3.8	3	C0200E1B	
250	3-13/16	4-1/2	4-3/8	10.1	97	114	111	4.6	3	C0250E1B	
300	3-13/16	4-1/2	4-3/4	11.2	97	114	121	5.1	3	C0300E1B	
350	3-13/16	4-1/2	5-1/4	13.2	97	114	133	6.0	3	C0350E1B	
500	4-3/4	5-1/4	5-5/8	17.5	121	133	143	7.9	3	C0500E1B	

Primary: 208/277

Secondary: 120 with Fuse Clips for 13/32 x 1-1/2 Fuses

50	2-9/16	3	3	2.9	65	76	76	1.3	4	C0050E3A	
75	2-9/16	3	3-1/2	3.8	65	76	89	1.7	4	C0075E3A	
100	2-7/8	3-3/8	3-3/8	4.5	73	86	86	2.0	4	C0100E3A	
150	3-3/16	3-3/4	4	6.9	81	95	102	3.1	4	C0150E3A	
200	3-13/16	4-1/2	4	8.7	97	114	102	3.9	4	C0200E3A	
250	3-13/16	4-1/2	4-3/8	10.2	97	114	111	4.6	4	C0250E3A	
300	3-13/16	4-1/2	4-3/4	11.4	97	114	121	5.2	4	C0300E3A	
350	3-13/16	4-1/2	5-1/4	13.7	97	114	133	6.2	4	C0350E3A	
500	4-3/4	5-1/4	5-3/8	17.2	121	133	136	7.8	4	C0500E3A	
750	4-3/4	5-1/4	7	25.7	121	133	178	11.7	4	C0750E3A	

① See Page 44-40 for Wiring Diagrams.

Note: For additional information, refer to the Cutler-Hammer Industrial Control Transformer Binder B1228A.

For other ratings or styles not shown, refer to Eaton.

Discount Symbol ..... DT-1

**Type MTE**

**Table 44-52. Type MTE — Product Selection**

VA	Dimensions (Inches)			Weight Lbs.	Dimensions (mm)			Weight kg	Wiring Diagram ①	Style Number	Price U.S. \$
	Height	Width	Depth		Height	Width	Depth				
<b>Primary: 240 x 480 with Jumpers</b>											
<b>Secondary: 120 x 240 with Jumpers, Secondary Fuse Clips not Applicable</b>											
50	2-9/16	3	3	2.6	65	76	76	1.2	11	C0050E2CXX	
75	2-9/16	3	3-1/2	3.5	65	76	89	1.6	11	C0075E2CXX	
100	2-7/8	3-3/8	3-3/8	4.2	73	86	86	1.9	11	C0100E2CXX	
150	3-3/16	3-3/4	4	6.7	81	95	102	3.1	11	C0150E2CXX	
200	3-13/16	4-1/2	4	8.5	97	114	102	3.9	11	C0200E2CXX	
250	3-13/16	4-1/2	4-3/8	10.0	97	114	111	4.6	11	C0250E2CXX	
300	3-13/16	4-1/2	4-7/8	11.8	97	114	124	5.4	11	C0300E2CXX	
350	3-13/16	4-1/2	5-1/4	13.6	97	114	133	6.2	11	C0350E2CXX	
500	4-3/4	5-1/4	5-1/4	17.5	121	133	133	8.0	11	C0500E2CXX	
750	4-3/4	5-1/4	7	26.4	121	133	178	12.0	11	C0750E2CXX	

**Primary: 550/575/600**

**Secondary: 110/115/120 with for 13/32 x 1-1/2 Fuses**

50	2-9/16	3	3	2.7	65	76	76	1.2	10	C0050E4C	
75	2-9/16	3	3-1/2	3.6	65	76	89	1.6	10	C0075E4C	
100	2-7/8	3-3/8	3-3/8	4.2	73	86	86	1.9	10	C0100E4C	
150	3-3/16	3-3/4	4	6.8	81	95	102	3.1	10	C0150E4C	
200	3-13/16	4-1/2	4	8.4	97	114	102	3.8	10	C0200E4C	
250	3-13/16	4-1/2	4-3/8	10.0	97	114	111	4.6	10	C0250E4C	
300	3-13/16	4-1/2	4-3/4	11.3	97	114	121	5.1	10	C0300E4C	
350	3-13/16	4-1/2	5-1/4	13.6	97	114	133	6.2	10	C0350E4C	
500	4-3/4	5-1/4	5-3/8	16.8	121	133	137	7.6	10	C0500E4C	
750	4-3/4	5-1/4	7	25.7	121	133	178	11.7	10	C0750E4C	

**Primary: 380/400/415**

**Secondary: 22/23/24 with Fuse Clips for 13/32 x 1-1/2 Fuses**

50	2-9/16	3	3	2.5	65	76	76	1.1	13	C0050E4H	
75	2-9/16	3	3-1/2	3.5	65	76	89	1.6	13	C0075E4H	
100	2-7/8	3-3/8	3-3/8	4.0	73	86	86	1.8	13	C0100E4H	
150	3-3/16	3-3/4	4	6.5	81	95	102	3.0	13	C0150E4H	
200	3-13/16	4-1/2	4	8.2	97	114	102	3.7	13	C0200E4H	
250	3-13/16	4-1/2	4-3/8	10.0	97	114	111	4.5	13	C0250E4H	
300	3-13/16	4-1/2	4-3/4	11.0	97	114	121	5.0	13	C0300E4H	
350	3-13/16	4-1/2	5-1/4	13.6	97	114	133	6.2	13	C0350E4H	
500	4-3/4	5-1/4	5-1/2	17.7	121	133	140	8.0	13	C0500E4H	

**Primary: 550/575/600**

**Secondary: 22/23/24 with Fuse Clips for 13/32 x 1-1/2 Fuses**

50	2-9/16	3	3	2.5	65	76	76	1.1	12	C0050E4W	
75	2-9/16	3	3-1/2	3.5	65	76	89	1.6	12	C0075E4W	
100	2-7/8	3-3/8	3 3/8	4.0	73	86	86	1.8	12	C0100E4W	
150	3-3/16	3-3/4	4	6.5	81	95	102	3.0	12	C0150E4W	
200	3-13/16	4-1/2	4	8.2	97	114	102	3.7	12	C0200E4W	
250	3-13/16	4-1/2	4-3/8	10.0	97	114	111	4.5	12	C0250E4W	
300	3-13/16	4-1/2	4-3/4	11.0	97	114	121	5.0	12	C0300E4W	
350	3-13/16	4-1/2	5-1/4	13.6	97	114	133	6.2	12	C0350E4W	
500	4-3/4	5-1/4	5-1/2	17.7	121	133	140	8.0	12	C0500E4W	
750	4-1/2	5-1/4	7-3/8	28.0	114	133	187	12.7	12	C0750E4WXX ②	

① See Page 44-41 for Wiring Diagrams.

② Secondary fuse clips are not available on this catalog number.

**Note:** For additional information, refer to the Cutler-Hammer Industrial Control Transformer Binder B1228A.

For other ratings or styles not shown, refer to Eaton.

Discount Symbol ..... DT-1

Type MTE

Table 44-53. Types MTE — Product Selection

VA	Dimensions (Inches)			Weight Lbs.	Dimensions (mm)			Weight kg	Wiring Diagram ①	Style Number	Price U.S. \$
	Height	Width	Depth		Height	Width	Depth				

Primary: 230/460/575

Secondary: 115/95 with Fuse Clips for 13/32 x 1-1/2 Fuses

50	2-9/16	3	3	3.5	65	76	76	1.6	5	C0050E3C	
75	2-7/8	3-3/8	3-3/8	4.5	73	86	86	2.0	5	C0075E3C	
100	2-7/8	3-3/8	3-7/8	6.0	73	86	98	2.7	5	C0100E3C	
150	3-3/16	3-3/4	4-1/4	7.7	81	95	108	3.5	5	C0150E3C	
200	3-13/16	4-1/2	4-1/4	9.0	97	114	108	4.1	5	C0200E3C	
250	3-13/16	4-1/2	4-3/4	9.7	97	114	121	4.4	5	C0250E3C	
300	3-13/16	4-1/2	5-1/8	11.7	97	114	130	5.3	5	C0300E3C	
350	4-3/4	5-1/4	5	16.5	121	133	127	7.5	5	C0350E3C	
500	4-3/4	5-1/4	5-5/8	21.5	121	133	143	9.8	5	C0500E3C	
750	4-3/4	5-1/4	7	28.0	121	133	178	12.7	5	C0750E3C	

Primary: 380/400/415

Secondary: 110 x 220 with Jumpers; Fuse Clips not Applicable

50	2-9/16	3	3	3.0	65	76	76	1.4	6	C0050E4D	
75	2-9/16	3	3-1/2	4.0	65	76	89	1.8	6	C0075E4D	
100	2-7/8	3-3/8	3-9/16	5.2	73	86	90	2.4	6	C0100E4D	
150	3-3/16	3-3/4	4	7.0	81	95	102	3.2	6	C0150E4D	
200	3-13/16	4-1/2	4	8.7	97	114	102	3.9	6	C0200E4D	
250	3-13/16	4-1/2	4-3/8	10.2	97	114	111	4.6	6	C0250E4D	
300	3-13/16	4-1/2	4-3/4	11.0	97	114	121	5.0	6	C0300E4D	
350	3-13/16	4-1/2	5-1/4	13.0	97	114	133	5.9	6	C0350E4D	
500	4-3/4	5-1/4	5-3/8	20.0	121	133	136	9.1	6	C0500E4D	
750	4-3/4	5-1/4	7	28.0	121	133	178	12.7	6	C0750E4D	

Primary: 200/220/440, 208/230/460, 240/480

Secondary: 23/110, 24/115, 25/120 with Fuse Clips for 13/32 x 1-1/2 Fuses

50	2-9/16	3	3-1/4	3.4	65	76	83	1.5	7	C0050E5E	
75	2-7/8	3-3/8	3-1/2	4.8	73	86	89	2.2	7	C0075E5E	
100	3-3/16	3-3/4	5-5/8	5.9	81	95	143	2.7	7	C0100E5E	
150	3-3/16	3-3/4	4-3/8	7.9	81	95	111	3.6	7	C0150E5E	
200	3-13/16	4-1/2	4-1/2	10.6	97	114	114	4.8	7	C0200E5E	
250	3-13/16	4-1/2	5-1/4	13.9	97	114	133	6.3	7	C0250E5E	
300	4-3/4	5-1/4	5-1/8	15.5	121	133	130	7.0	7	C0300E5E	
350	4-3/4	5-1/4	5-3/8	16.8	121	133	136	7.6	7	C0350E5E	
500	4-3/4	5-1/4	6-7/8	23.4	121	133	175	10.6	7	C0500E5E	

Universal Design (MTE Epoxy Encapsulated)

Primary: 240/416/480/600, 230/400/460/575, 220/380/440/550, 208/500

Secondary: 99/120/130, 95/115/125, 91/110/120, 85/100/110 with Fuse Clips for 13/32 x 1-1/2 Fuses

50	2-7/8	3-3/8	4	4.0	73	86	102	1.8	8	C0050E6U ②	
100	3-3/16	3-3/4	4-5/8	6.6	81	95	117	3.0	8	C0100E6U ②	
150	3-13/16	4-1/2	4-7/16	8.8	97	114	113	4.0	8	C0150E6U ③	
250	3-13/16	4-1/2	5-7/8	14.7	97	114	149	6.7	8	C0250E6U ③	
350	4-7/16	5-1/4	5-5/8	18.6	113	133	143	8.4	8	C0350E6U ③	
500	4-7/16	5-1/4	7	25.6	113	133	178	11.6	8	C0500E6U ③	
750	5-3/4	6-3/4	5-11/16	30.5	146	171	144	13.8	8	C0750E6U ③	

① See Pages 44-40 and 44-41 for Wiring Diagrams.

② Type MTG Open Core-Coil Universal Design has been superseded by Type MTE Epoxy Encapsulated Universal Design with no changes to form, fit or function.

③ Type MTE Epoxy Encapsulated Universal Design.

Note: For additional information, refer to the Cutler-Hammer Industrial Control Transformer Binder B1228A.

For other ratings or styles not shown, refer to Eaton.

Discount Symbol ..... DT-1

**Type MTE**

**Table 44-54. Transformers with Primary Fuse Blocks — Product Selection**

VA	Dimensions (Inches)			Weight Lbs.	Dimensions (mm)			Weight kg	Wiring Diagram ①	Style Number	Price U.S. \$
	Height	Width	Depth		Height	Width	Depth				

**Primary: 240 x 480, 230 x 460, 220 x 440 with Jumpers and Two-Pole Primary Fuse Block for Rejection Type Fuses**  
**Secondary: 120/115/110 with Fuse Clips for 13/32 x 1-1/2 Fuses**

50	3-15/16	3	3	2.8	100	76	76	1.3	1	C0050E2AFB	
75	3-15/16	3	3-1/2	3.7	100	76	89	1.7	1	C0075E2AFB	
100	4-1/4	3-3/8	3-3/8	4.4	108	86	86	2.0	1	C0100E2AFB	
150	4-9/16	3-3/4	4	6.9	116	95	102	3.1	1	C0150E2AFB	
200	5-3/16	4-1/2	4	8.7	132	114	102	3.9	1	C0200E2AFB	
250	5-3/16	4-1/2	4-3/8	10.2	132	114	111	4.6	1	C0250E2AFB	
300	5-3/16	4-1/2	4-3/4	11.5	132	114	121	5.2	1	C0300E2AFB	
350	5-3/16	4-1/2	5-1/4	13.8	132	114	133	6.3	1	C0350E2AFB	
500	6-1/8	5-1/4	5-1/2	19.4	156	133	140	8.8	1	C0500E2AFB	
750	6-1/8	5-1/4	7	28.3	156	133	178	12.8	1	C0750E2AFB	
1000	7-1/16	6-3/4	6-7/16	29.7	179	171	164	13.4	1	C1000E2AFB	
1500	7-3/4	7-1/2	7-3/8	40.2	197	191	187	18.1	1	C1500E2AFB	

**Primary: 240 x 480 with Jumpers and Two-Pole Primary Fuse Block for Rejection Type Fuses**  
**Secondary: 24 with Fuse Clips for 13/32 x 1-1/2 Fuses**

50	3-15/16	3	3	2.8	100	76	76	1.3	2	C0050E2BFB	
75	3-15/16	3	3-1/2	3.8	100	76	89	1.7	2	C0075E2BFB	
100	4-1/4	3-3/8	3-3/8	4.4	108	86	86	2.1	2	C0100E2BFB	
150	4-9/16	3-3/4	4	6.9	116	95	102	3.1	2	C0150E2BFB	
200	5-3/16	4-1/2	4	8.7	132	114	102	3.9	2	C0200E2BFB	
250	5-3/16	4-1/2	4-3/8	10.3	132	114	111	4.7	2	C0250E2BFB	
300	5-3/16	4-1/2	4-3/4	11.6	132	114	121	5.3	2	C0300E2BFB	
350	5-3/16	4-1/2	5-1/4	13.6	132	114	133	6.2	2	C0350E2BFB	
500	6-1/8	5-1/4	5-5/8	17.7	156	133	143	8.0	2	C0500E2BFB	

**Primary: 120 x 240 with Jumpers and Two-Pole Primary Fuse Block for Rejection Type Fuses**  
**Secondary: 24 with Fuse Clips for 13/32 x 1-1/2 Fuses**

50	3-15/16	3	3	2.8	100	76	76	1.3	3	C0050E1BFB	
75	3-15/16	3	3 1/2	3.8	100	76	89	1.7	3	C0075E1BFB	
100	4-1/4	3-3/8	3 3/8	4.6	108	86	86	2.1	3	C0100E1BFB	
150	4-9/16	3-3/4	4	6.9	116	95	102	3.1	3	C0150E1BFB	
200	5-3/16	4-1/2	4	8.5	132	114	102	3.9	3	C0200E1BFB	
250	5-3/16	4-1/2	4 3/8	10.3	132	114	111	4.7	3	C0250E1BFB	
300	5-3/16	4-1/2	4 3/4	11.4	132	114	121	5.2	3	C0300E1BFB	
350	5-3/16	4-1/2	5 1/4	13.4	132	114	133	6.1	3	C0350E1BFB	
500	6-1/8	5-1/4	5 5/8	17.7	156	133	143	8.0	3	C0500E1BFB	

**Primary: 208/277 with Two-Pole Primary Fuse Block for Rejection Type Fuses**  
**Secondary: 120 with Fuse Clips for 13/32 x 1-1/2 Fuses**

50	3-15/16	3	3	3.1	100	76	76	1.4	4	C0050E3AFB	
75	3-15/16	3	3-1/2	4.0	100	76	89	1.8	4	C0075E3AFB	
100	4-1/4	3-3/8	3-3/8	4.7	108	86	86	2.1	4	C0100E3AFB	
150	4-9/16	3-3/4	4	7.1	116	95	102	3.2	4	C0150E3AFB	
200	5-3/16	4-1/2	4	8.9	132	114	102	4.0	4	C0200E3AFB	
250	5-3/16	4-1/2	4-3/8	10.4	132	114	111	4.7	4	C0250E3AFB	
300	5-3/16	4-1/2	4-3/4	11.6	132	114	121	5.3	4	C0300E3AFB	
350	5-3/16	4-1/2	5-1/4	13.9	132	114	133	6.3	4	C0350E3AFB	
500	6-1/8	5-1/4	5-3/8	17.4	156	133	143	7.9	4	C0500E3AFB	

① See Page 44-40 for Wiring Diagrams.

**Note:** For additional information, refer to the Cutler-Hammer Industrial Control Transformer Binder B1228A.

For other ratings or styles not shown, refer to Eaton.

Discount Symbol ..... DT-1

Type MTE

Table 44-55. Transformers with Primary Fuse Blocks — Product Selection

VA	Dimensions (Inches)			Weight Lbs.	Dimensions (mm)			Weight kg	Wiring Diagram ①	Style Number	Price U.S. \$
	Height	Width	Depth		Height	Width	Depth				

Primary: 550/575/600 with Two-Pole Primary Fuse Block for Rejection Type Fuses

Secondary: 110/115/120 with Fuse Clips for 13/32 x 1-1/2 Fuses

50	3-15/16	3	3	2.9	100	76	76	1.3	10	C0050E4CFB	
75	3-15/16	3	3-1/2	3.8	100	76	89	1.7	10	C0075E4CFB	
100	4-1/4	3-3/8	3 3/8	4.4	108	86	86	2.0	10	C0100E4CFB	
150	4-9/16	3-3/4	4	7.0	116	95	102	3.2	10	C0150E4CFB	
200	5-3/16	4-1/2	4	8.6	132	114	102	3.9	10	C0200E4CFB	
250	5-3/16	4-1/2	4 3/8	10.2	132	114	111	4.6	10	C0250E4CFB	
300	5-3/16	4-1/2	4 3/4	11.5	132	114	121	5.2	10	C0300E4CFB	
350	5-3/16	4-1/2	5 1/4	13.8	132	114	133	6.3	10	C0350E4CFB	
500	6-1/8	5-1/4	5 3/8	17.0	156	133	137	7.7	10	C0500E4CFB	
750	6-1/8	5-1/4	7	25.9	156	133	178	11.8	10	C0750E4CFB	

Primary: 380/400/415 with Two-Pole Primary Fuse Block for Rejection Type Fuses

Secondary: 22/23/24 with Fuse Clips for 13/32 x 1-1/2 Fuses

50	2-9/16	3	3	2.6	65	76	76	1.2	13	C0050E4HFB	
75	2-9/16	3	3-1/2	3.7	65	76	89	1.7	13	C0075E4HFB	
100	2-7/8	3-3/8	3-3/8	4.2	73	86	86	1.9	13	C0100E4HFB	
150	3-3/16	3-3/4	4	6.7	81	95	102	3.0	13	C0150E4HFB	
200	3-13/16	4-1/2	4	8.4	97	114	102	3.8	13	C0200E4HFB	
250	3-13/16	4-1/2	4-3/8	10.2	97	114	111	4.6	13	C0250E4HFB	

Primary: 550/575/600 with Two-Pole Primary Fuse Block for Rejection Type Fuses

Secondary: 22/23/24 with Fuse Clips for 13/32 x 1-1/2 Fuses

50	2-9/16	3	3	2.7	65	76	76	1.2	12	C0050E4WFB	
75	2-9/16	3	3-1/2	3.7	65	76	89	1.7	12	C0075E4WFB	
100	2-7/8	3-3/8	3-3/8	4.2	73	86	86	1.9	12	C0100E4WFB	
150	3-3/16	3-3/4	4	6.7	81	95	102	3.0	12	C0150E4WFB	
200	3-13/16	4-1/2	4	8.4	97	114	102	3.8	12	C0200E4WFB	
250	3-13/16	4-1/2	4-3/8	10.2	97	114	111	4.6	12	C0250E4WFB	

① See Page 44-41 for Wiring Diagrams.

Note: For additional information, refer to the Cutler-Hammer Industrial Control Transformer Binder B1228A.

For other ratings or styles not shown, refer to Eaton.

Discount Symbol ..... DT-1

**Type MTE**

**Table 44-56. Transformers with Primary Fuse Blocks — Product Selection**

VA	Dimensions (Inches)			Weight Lbs.	Dimensions (mm)			Weight kg	Wiring Diagram ①	Style Number	Price U.S. \$
	Height	Width	Depth		Height	Width	Depth				

**Primary: 230/460/575 with Two-Pole Primary Fuse Block for Rejection Type Fuses**  
**Secondary: 115/95 with Fuse Clips for 13/32 x 1-1/2 Fuses**

50	3-13/16	3	3	3.7	97	76	76	1.7	5	C0050E3CFB	
75	4-1/4	3-3/8	3-3/8	4.7	108	86	86	2.1	5	C0075E3CFB	
100	4-1/4	3-3/8	3-7/8	6.2	108	86	98	2.8	5	C0100E3CFB	
150	4-9/16	3-3/4	4-1/4	7.9	116	95	108	3.6	5	C0150E3CFB	
200	5-3/16	4-1/2	4-1/4	9.2	132	114	108	4.2	5	C0200E3CFB	
250	5-3/16	4-1/2	4-3/4	9.9	132	114	121	4.5	5	C0250E3CFB	
300	5-3/16	4-1/2	5-1/8	11.9	132	114	130	5.4	5	C0300E3CFB	
350	6-1/8	5-1/4	5	16.7	156	133	127	7.6	5	C0350E3CFB	
500	6-1/8	5-1/4	5-7/8	21.7	156	133	149	9.9	5	C0500E3CFB	

**Primary: 380/400/415 with Two-Pole Primary Fuse Block for Rejection Type Fuses**  
**Secondary: 110 x 220 with Jumpers; Fuse Clips Not Available**

50	3-15/16	3	3	3.2	100	76	76	1.5	6	C0050E4DFB	
75	3-15/16	3	3-1/2	4.2	100	76	89	1.9	6	C0075E4DFB	
100	4-1/4	3-3/8	3-9/16	5.4	108	86	90	2.5	6	C0100E4DFB	
150	4-9/16	3-3/4	4	7.2	116	95	102	3.3	6	C0150E4DFB	
200	5-3/16	4-1/2	4	8.9	132	114	102	4.0	6	C0200E4DFB	
250	5-3/16	4-1/2	4-3/8	10.4	132	114	111	4.7	6	C0250E4DFB	
300	5-3/16	4-1/2	4-3/4	11.2	132	114	121	5.1	6	C0300E4DFB	
350	5-3/16	4-1/2	5-1/4	13.2	132	114	133	6.0	6	C0350E4DFB	
500	6-1/8	5-1/4	5-5/8	20.2	156	133	143	9.2	6	C0500E4DFB	

**Primary: 200/220/440, 208/230/460, 240/480 with Two-Pole Primary Fuse Block for Rejection Type Fuses**  
**Secondary: 23/110, 24/115, 25/120 with Fuse Clips for 13/32 x 1-1/2 Fuses**

50	3-15/16	3	3-1/4	3.6	100	76	83	1.6	7	C0050E5EFB	
75	4-1/4	3-3/8	3-1/2	5.0	108	86	89	2.3	7	C0075E5EFB	
100	4-9/16	3-3/4	3-5/8	6.1	116	95	92	2.8	7	C0100E5EFB	
150	4-9/16	3-3/4	4-3/8	8.1	116	95	111	3.7	7	C0150E5EFB	
200	5-3/16	4-1/2	4-1/2	10.8	132	114	114	4.9	7	C0200E5EFB	
250	5-3/16	4-1/2	5-1/4	14.1	132	114	133	6.4	7	C0250E5EFB	
300	6-1/8	5-1/4	5-1/8	15.7	156	133	130	7.1	7	C0300E5EFB	
350	6-1/8	5-1/4	5-3/8	17.0	156	133	136	7.7	7	C0350E5EFB	
500	6-1/8	5-1/4	6-7/8	23.6	156	133	175	10.7	7	C0500E5EFB	

**Universal Design (MTE Epoxy Encapsulated)**

**Primary: 240/416/480/600, 230/400/460/575, 220/380/440/550, 208/500 with Two-Pole Primary Fuse Block for Rejection Type Fuses**  
**Secondary: 99/120/130, 95/115/125, 91/110/120, 85/100/110 with Fuse Clips for 13/32 x 1-1/2 Fuses**

50	4-1/4	3-3/8	4	4.2	108	86	102	1.9	8	C0050E6UFB ②	
100	4-9/16	3-3/4	4-5/8	6.8	116	95	117	3.1	8	C0100E6UFB ②	
150	5-3/16	4-1/2	4-7/16	9.0	132	114	113	4.1	8	C0150E6UFB ③	
250	5-3/16	4-1/2	5-7/8	14.9	132	114	149	6.8	8	C0250E6UFB ③	
350	5-13/16	5-1/4	5-5/8	18.8	148	133	143	8.5	8	C0350E6UFB ③	
500	5-13/16	5-1/4	7	25.8	148	133	178	11.7	8	C0500E6UFB ③	

① See Pages 44-40 and 44-41 for Wiring Diagrams.

② Type MTG Open Core-Coil Universal Design has been superseded by Type MTE Epoxy Encapsulated Universal Design with no changes to form, fit or function.

③ Type MTE Epoxy Encapsulated Universal Design.

**Note:** For additional information, refer to the Cutler-Hammer Industrial Control Transformer Binder B1228A.

For other ratings or styles not shown, refer to Eaton.

Discount Symbol ..... DT-1

## Type MTK

## Type MTK



Type MTK Transformers

## Product Description

- Epoxy resin-impregnated coil.
- Economical solution for high inrush applications.

## Application Description

Transformers provide stepped down voltages to machine tool control devices enabling control circuits to be isolated from all power and lighting circuits. This allows the use of grounded or ungrounded circuits that are independent of the power or lighting grounds; greater safety is afforded the operator. The control transformer line is particularly adaptable on applications where compact construction is demanded.

## Features, Benefits and Functions

- UL listed.
- CSA certified.
- Epoxy resin impregnated coil design.
- Copper magnet wire for high quality, efficient operation.
- 50/60 Hz operation.
- 115°C rise, 180°C insulation system.
- Performance meets/exceeds requirements of ANSI/NEMA ST-1.
- Regulation exceeds ANSI/NEMA requirements for all ratings.
- 500 – 5000 VA ratings.

## Standards and Certifications

## Industry Standards

All Cutler-Hammer dry-type distribution and control transformers by Eaton Corporation are built and tested in accordance with applicable NEMA, ANSI, and IEEE Standards. All 600 volt class transformers are UL listed unless otherwise noted.

## Product Specifications

## Insulation System and Temperature Rise

Industry standards classify insulation systems and rise as shown below:

Table 44-57. Insulation System Classification

Ambient	+ Winding Rise	+ Hot Spot	= Temp. Class
40°C	55°C	10°C	105°C
40°C	80°C	30°C	150°C
40°C	115°C	30°C	185°C
40°C	150°C	30°C	220°C

The design life of transformers having different insulation systems is the same — the lower temperature systems are designed for the same life as the higher temperature systems.

## Series-Multiple Windings

Series-multiple windings consist of 2 similar coils in each winding which can be connected in series or parallel (multiple). Transformers with series-multiple windings are designated with an "X" or "/" between the voltage ratings, such as voltages of "120/240" or "240 X 480." If the series-multiple winding is designated by an "X," the winding can be connected only for a series or parallel. With the "/" designation, a mid-point also becomes available in addition to the series or parallel connection. As an example, a 120 X 240 winding can be connected for either 120 (parallel) or 240 (series), but a 120/240 winding can be connected for 120 (parallel), or 240 (series), or 240 with a 120 mid-point.

The following pages provide listings for most standard transformer ratings and styles.

For other ratings or styles not shown, refer to Eaton.



Type MTK

Wiring Diagrams

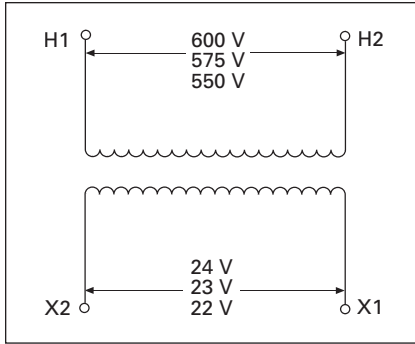

Figure 44-34. Diagram 12

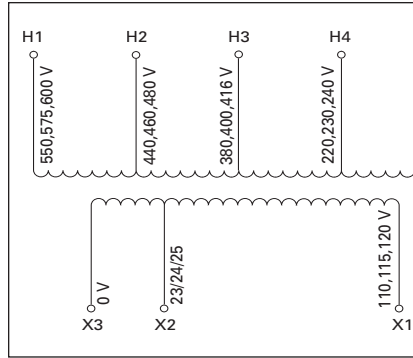

Figure 44-36. Diagram 14

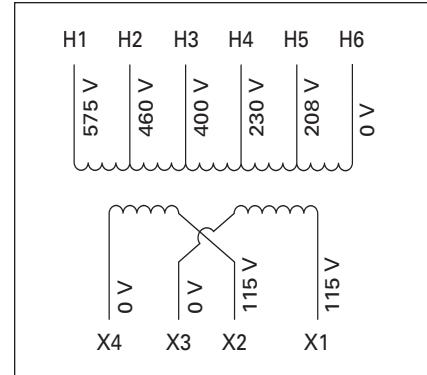

Figure 44-38. Diagram 16

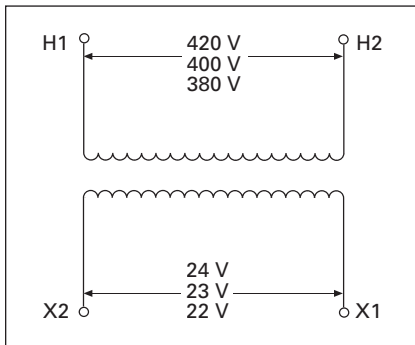

Figure 44-35. Diagram 13

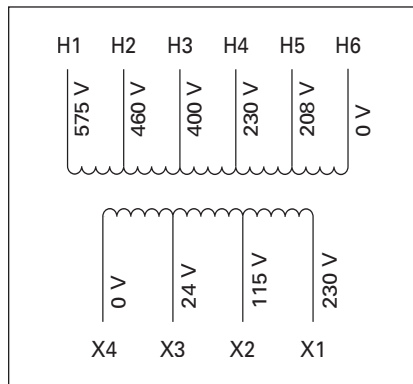

Figure 44-37. Diagram 15

**Type MTK**

**Product Selection**

Additional Product Selection information begins on **Page 44-63**.

**Table 44-58. Type MTK — Product Selection**

VA	Dimensions (Inches)			Weight Lbs.	Dimensions (mm)			Weight kg	Wiring Diagram ①	Style Number	Price U.S. \$
	Height	Width	Depth		Height	Width	Depth				
<b>Primary: 240 x 480, 230 x 460, 220 x 440</b>											
<b>Secondary: 120/115/110</b>											
500	3-13/16	4-1/2	6	13.0	97	114	152	5.9	1	C0500K2A	
750	4-7/16	5-1/2	6-1/2	19.5	113	133	165	8.9	1	C0750K2A	
1000	4-7/16	5-1/4	7-7/8	29.8	113	133	200	13.6	1	C1000K2A	
1500	5-11/16	6-3/4	6-3/4	30.0	144	171	171	13.6	1	C1500K2A	
2000	5-11/16	6-3/4	7	38.0	144	171	178	17.3	1	C2000K2A	
3000	7-9/16	9	7-1/2	53.0	192	229	191	24.1	1	C3000K2A	
5000	7-9/16	9	7-3/4	89.0	192	229	197	40.5	1	C5000K2A	
<b>Primary: 208/277</b>											
<b>Secondary: 120</b>											
1000	5-3/8	6-3/8	7-1/8	29.0	137	162	181	13.1	4	C1000K3A	
1500	5-11/16	6-3/4	7-1/2	33.0	144	171	191	15.0	4	C1500K3A	
2000	5-11/16	6-3/4	8-1/4	43.0	144	171	210	19.5	4	C2000K3A	
3000	7-5/8	9	8-1/4	64.0	194	229	210	29.0	4	C3000K3A	
5000	10-3/16	9	10-1/2	102.0	259	229	267	46.3	4	C5000K3A	
<b>Primary: 230/460/575</b>											
<b>Secondary: 115/95</b>											
1000	5-3/8	6-3/8	7-1/8	29.2	137	162	184	13.3	5	C1000K3C	
1500	5-11/16	6-3/4	8-1/4	33.5	144	171	210	15.2	5	C1500K3C	
2000	7-9/16	9	7-9/16	42.5	192	229	192	19.3	5	C2000K3C	
3000	7-9/16	9	8-5/8	63.7	192	229	219	29.0	5	C3000K3C	
5000	7-3/16	9	13-1/2	102.0	259	229	343	46.4	5	C5000K3C	
<b>Primary: 208/380/416</b>											
<b>Secondary: 115/95</b>											
1000	5-3/8	6-3/8	7-1/8	29.0	137	162	181	13.1	9	C1000K3D	
1500	5-11/16	6-3/4	8-1/4	43.0	144	171	210	19.5	9	C1500K3D	
2000	5-11/16	6-3/4	9-1/4	55.0	144	171	235	25.0	9	C2000K3D	
3000	7-5/8	9	8-5/8	74.0	194	229	219	33.5	9	C3000K3D	
5000	10-3/16	9	11	108.0	259	229	279	49.0	9	C5000K3D	
<b>Primary: 550/575/600</b>											
<b>Secondary: 110/115/120</b>											
1000	5-3/8	6-3/8	7-1/8	29.0	137	162	181	13.1	10	C1000K4C	
1500	5-11/16	6-3/4	7-1/2	33.0	144	171	191	15.0	10	C1500K4C	
2000	5-11/16	6-3/4	8-1/4	43.0	144	171	210	19.5	10	C2000K4C	
3000	7-5/8	9	8-1/4	64.0	194	229	210	29.0	10	C3000K4C	
5000	10-3/16	9	10-1/2	102.0	259	229	267	46.3	10	C5000K4C	
<b>Primary: 380/400/415</b>											
<b>Secondary: 110 x 220</b>											
1000	5-11/16	6-3/4	6-1/2	28.0	144	171	165	12.7	6	C1000K4D	
1500	5-11/16	6-3/4	7-1/2	33.0	144	171	191	15.0	6	C1500K4D	
2000	5-11/16	6-3/4	8-1/4	43.0	144	171	210	19.5	6	C2000K4D	
3000	7-5/8	9	8-1/4	64.0	194	229	210	29.0	6	C3000K4D	
5000	10-3/16	9	10-1/2	102.0	259	229	267	46.3	6	C5000K4D	

① See **Page 44-49** and for Wiring Diagrams.

**Note:** For additional information, refer to the Cutler-Hammer Industrial Control Transformer Binder B1228A.

For other ratings or styles not shown, refer to Eaton.

Discount Symbol ..... **DT-1**

Type MTK

Table 44-59. Type MTK — Product Selection

VA	Dimensions (Inches)			Weight Lbs.	Dimensions (mm)			Weight kg	Wiring Diagram ①	Style Number	Price U.S. \$
	Height	Width	Depth		Height	Width	Depth				
<b>Primary: 240 x 480 with Jumpers</b>											
<b>Secondary: 120 x 240 with Jumpers, Secondary Fuse Clips Not Applicable</b>											
1000	4-7/16	5-1/4	7-7/8	26.4	113	133	200	12.0	11	C1000K2CXX	
1500	5-11/16	6-3/4	7-1/4	31.0	144	171	184	14.1	11	C1500K2CXX	
2000	5-3/4	6-3/4	8	40.0	146	171	203	18.2	11	C2000K2CXX	
3000	7-5/8	9	7-1/2	56.0	194	229	191	25.5	11	C3000K2CXX	
5000	7-5/8	9	9-1/4	85.5	194	229	235	28.9	11	C5000K2CXX	
<b>Primary: 120 x 240 with Jumpers</b>											
<b>Secondary: 24</b>											
750	4-1/2	5-1/4	6-3/4	19.0	114	133	171	8.6	3	C0750K1B	
1000	4-1/2	5-1/4	8-3/4	26.4	114	133	222	12.0	3	C1000K1B	
<b>Primary: 240/416/480/600, 230/400/460/575, 220/380/440/550, 208/500</b>											
<b>Secondary: 99/120/130, 95/115/125, 91/110/120, 85/100/110</b>											
1000	5-3/4	6-3/4	6-1/2	26.5	146	171	165	12.0	8	C1000K6U	
1500	5-3/4	6-3/4	7-7/8	38.5	146	171	200	17.5	8	C1500K6U	
2000	5-3/4	6-3/4	9-3/16	52.0	146	171	233	23.6	8	C2000K6U	
3000	7-3/4	9	7-1/2	68.0	197	229	191	30.9	8	C3000K6U	
5000	9-7/8	9	10-1/2	105.0	248	229	267	47.7	8	C5000K6U	

① See Page 44-49 for Wiring Diagrams.

**Note:** For additional information, refer to the Cutler-Hammer Industrial Control Transformer Binder B1228A.

For other ratings or styles not shown, refer to Eaton.

Discount Symbol ..... DT-1

**CE Marked**



*Terminal Type A*

**Application Description**

Transformers provide stepped down voltages to machine tool control devices enabling control circuits to be isolated from all power and lighting circuits. This allows the use of grounded or ungrounded circuits that are independent of the power or lighting grounds; greater safety is afforded the operator. The control transformer line is particularly adaptable on applications where compact construction is demanded.

**Features, Benefits and Functions**

**Type MTE**

- CE marked units comply with IEC EN-61558-2.
- UL listed.
- CSA certified.
- Epoxy encapsulated coil design.
- Copper magnet wire for high quality, efficient operation.
- Laminations of high quality silicon steel to minimize core losses and optimize performance.
- Molded-in terminals.
- 50/60 Hz operation.
- 55°C rise, class 105 insulation.
- Performance meets/exceeds requirements of ANSI/NEMA ST-1.
- Regulation exceeds ANSI/NEMA requirements for all ratings.
- Non-short circuit proof transformer, isolation type.

**Type MTK**

- CE marked units comply with IEC EN-61558-2.
- UL listed.
- CSA certified.
- Epoxy resin-impregnated coil design.
- Copper magnet wire for high quality, efficient operation.
- 50/60 Hz operation.
- 115°C rise, 180°C insulation system.
- Performance meets/exceeds requirements of ANSI/NEMA ST-1.
- Regulation exceeds ANSI/NEMA requirements for all ratings.
- 500 – 5000 VA ratings.

**Standards and Certifications**

**Industry Standards**

All Cutler-Hammer dry-type distribution and control transformers by Eaton Corporation are built and tested in accordance with applicable NEMA, ANSI, and IEEE Standards. All 600 volt class transformers are UL listed unless otherwise noted.

**Options and Accessories**

**Protection Index IP00**

When terminal covers are installed on primary and secondary, and fuse block covers are used, the Protection Index is IP20.

**Finger-Safe Terminal Covers (Optional)**

- Fits CE marked designs 50 – 750 VA.
- Fits MTE designs 25 – 750 VA.

**Table 44-60. Finger-Safe Terminal Covers**

Description	Catalog Number	Price U.S. \$
4 Terminal Transformers	<b>FSK4</b>	
6 Terminal Transformers	<b>FSK6</b>	



*Finger-Safe Terminal Covers — FSK4*



*Finger-Safe Terminal Covers — FSK6*

**Finger-Safe Primary Fuse Block Covers**

- Fits 2-pole primary fuse blocks on MTE designs.

**Table 44-61. Finger-Safe Primary Fuse Block Covers**

Description	Catalog Number	Price U.S. \$
Primary Fuse Block Covers	<b>FSKFB</b>	



*Finger-Safe Primary Fuse Block Covers*

CE Marked

## Product Specifications

### Overload Capability

Short-term overload is designed into transformers as required by ANSI. Basically, dry-type distribution transformers will deliver 200% nameplate load for one-half hour; 150% load for one-hour; and 125% load for four-hours without being damaged provided that a constant 50% load precedes and follows the overload. See ANSI C57.96-01.250 for additional limitations.

Continuous overload capacity is not deliberately designed into a transformer because the design objective is to be within the allowed winding temperature rise with nameplate loading.

### Insulation System and Temperature Rise

Industry standards classify insulation systems and rise as shown below:

Table 44-62. Insulation System Classification

Ambient	+ Winding Rise	+ Hot Spot	= Temp. Class
40°C	55°C	10°C	105°C
40°C	80°C	30°C	150°C
40°C	115°C	30°C	185°C
40°C	150°C	30°C	220°C

The design life of transformers having different insulation systems is the same — the lower temperature systems are designed for the same life as the higher temperature systems.

### Series-Multiple Windings

Series-multiple windings consist of 2 similar coils in each winding which can be connected in series or parallel (multiple). Transformers with series-multiple windings are designated with an "X" or "/" between the voltage ratings, such as voltages of "120/240" or "240 X 480." If the series-multiple winding is designated by an "X," the winding can be connected only for a series or parallel. With the "/" designation, a mid-point also becomes available in addition to the series or parallel connection. As an example, a 120 X 240 winding can be connected for either 120 (parallel) or 240 (series), but a 120/240 winding can be connected for 120 (parallel), or 240 (series), or 240 with a 120 mid-point.

## Wiring Diagrams

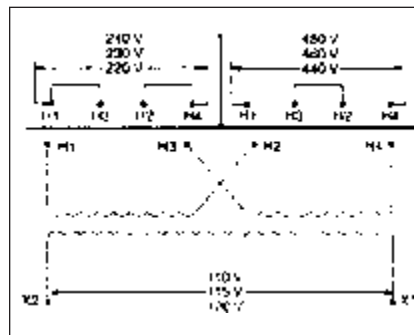

Figure 44-39. Diagram 1

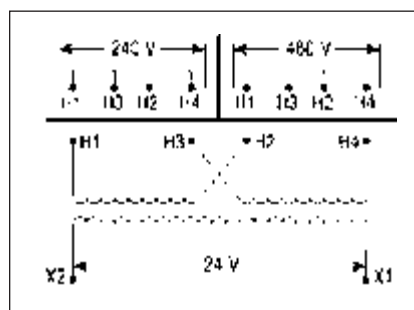

Figure 44-40. Diagram 2

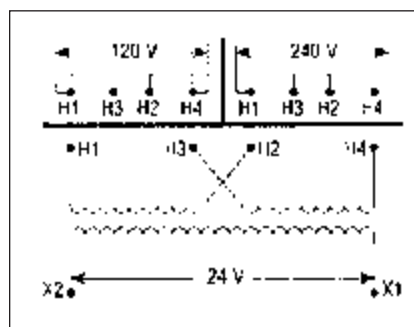

Figure 44-41. Diagram 3

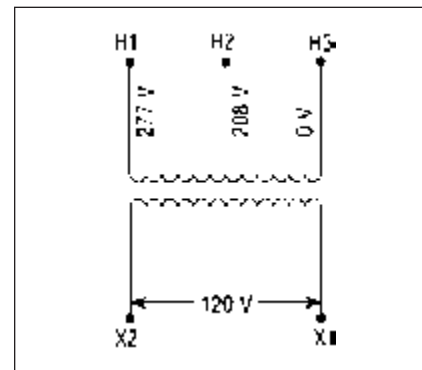

Figure 44-42. Diagram 4

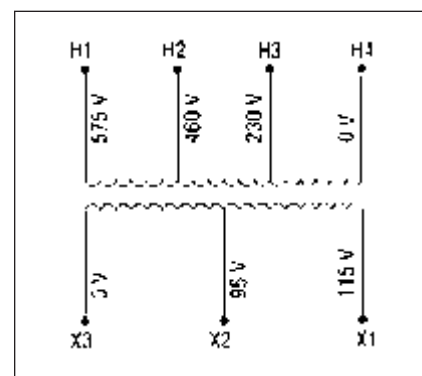

Figure 44-43. Diagram 5

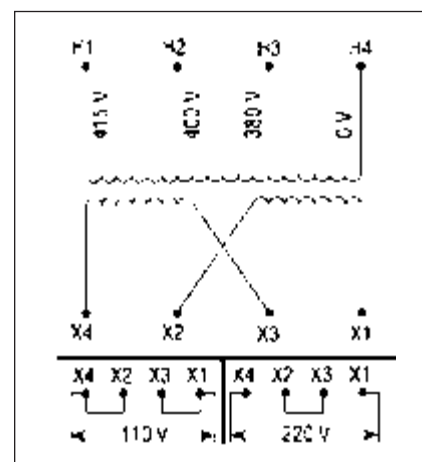

Figure 44-44. Diagram 6



CE Marked

## Product Selection

Additional Product Selection information begins on **Page 44-63**.

**Table 44-63. Type MTE CE Marked IP00**

VA	Dimensions (Inches)			Weight Lbs.	Dimensions (mm)			Weight kg	Wiring Diagram ①	Style Number	Price U.S. \$
	Height	Width	Depth		Height	Width	Depth				
<b>Primary: 240 x 480, 230 x 460, 220 x 440 with Jumpers</b>											
<b>Secondary: 120/115/110</b>											
50	3	3	3-3/8	3.5	76	76	86	1.6	1	CE0050E2ACE	
75	3-1/4	3-3/8	3-3/8	4.8	83	86	86	2.2	1	CE0075E2ACE	
100	3-1/2	3-3/4	3-3/8	5.9	89	95	86	2.7	1	CE0100E2ACE	
150	4	4-1/2	3-3/4	8.5	102	114	95	3.9	1	CE0150E2ACE	
200	4	4-1/2	3-3/4	10.6	102	114	95	4.8	1	CE0200E2ACE	
250	4	4-1/2	4	11.3	102	114	102	5.1	1	CE0250E2ACE	
300	4	4-1/2	4-3/8	13.2	102	114	111	6.0	1	CE0300E2ACE	
350	4-1/2	5-1/4	4-7/8	14.9	114	133	124	6.8	1	CE0350E2ACE	
500	4-1/2	5-1/4	5-1/8	21.0	114	133	130	9.5	1	CE0500E2ACE	
750	4-1/2	5-1/4	7	29.8	114	133	178	13.5	1	CE0750E2ACE	

**Primary: 240 x 480 with Jumpers**

**Secondary: 24**

50	3	3	3-3/8	3.4	76	76	86	1.5	2	CE0050E2BCE	
75	3-1/4	3-3/8	3-3/8	4.2	83	86	86	1.9	2	CE0075E2BCE	
100	3-1/2	3-3/4	3-3/8	5.9	89	95	86	2.7	2	CE0100E2BCE	
150	4	4-1/2	4	8.5	102	114	102	3.9	2	CE0150E2BCE	
200	4	4-1/2	3-3/4	10.6	102	114	95	4.5	2	CE0200E2BCE	
250	4	4-1/2	4	11.3	102	114	102	5.1	2	CE0250E2BCE	
300	4	4-1/2	4-3/8	13.2	102	114	111	6.0	2	CE0300E2BCE	
350	4-1/2	5-1/4	4-1/2	14.9	114	133	114	6.8	2	CE0350E2BCE	
500	4-1/2	5-1/4	5-1/8	19.2	114	133	130	8.7	2	CE0500E2BCE	
750	5	5-1/4	7	28.1	127	133	178	12.8	2	CE0750E2BCE	

**Primary: 120 x 240 with Jumpers**

**Secondary: 24**

50	3	3	3-3/8	3.4	76	76	86	1.5	3	CE0050E1BCE	
75	3-1/4	3-3/8	3-3/8	4.2	83	86	86	1.9	3	CE0075E1BCE	
100	3-1/2	3-3/4	3-3/8	5.9	89	95	86	2.7	3	CE0100E1BCE	
150	4	4-1/2	3-3/4	8.5	102	114	95	3.9	3	CE0150E1BCE	
200	4	4-1/2	3-3/4	10.6	102	114	95	4.5	3	CE0200E1BCE	
250	4	4-1/2	4	11.3	102	114	102	5.1	3	CE0250E1BCE	
300	4	4-1/2	4-3/8	13.2	102	114	111	6.0	3	CE0300E1BCE	
350	4-1/2	5-1/4	4-1/2	14.9	114	133	114	6.8	3	CE0350E1BCE	
500	4-1/2	5-1/4	5-1/8	19.2	114	133	130	8.7	3	CE0500E1BCE	
750	4-1/2	5-1/4	7	29.8	114	133	178	13.5	3	CE0750E1BCE	

**Primary: 550/575/600**

**Secondary: 110/115/120**

50	3	3	3-3/8	3.5	76	76	86	1.6	10	CE0050E4CCE	
75	3-1/4	3-3/8	3-3/8	4.8	83	86	86	2.2	10	CE0075E4CCE	
100	3-1/2	3-3/4	3-3/8	5.9	89	95	86	2.7	10	CE0100E4CCE	
150	4	4-1/2	3-3/4	8.5	102	114	95	3.9	10	CE0150E4CCE	
200	4	4-1/2	3-3/4	10.6	102	114	95	4.8	10	CE0200E4CCE	
250	4	4-1/2	4	11.3	102	114	102	5.1	10	CE0250E4CCE	
300	4	4-1/2	4-3/8	13.2	102	114	111	6.0	10	CE0300E4CCE	
350	4-1/2	5-1/4	4-1/2	14.9	114	133	114	6.8	10	CE0350E4CCE	
500	4-1/2	5-1/4	5-1/8	21.0	114	133	130	9.5	10	CE0500E4CCE	
750	4-1/2	5-1/4	7	29.8	114	133	178	13.5	10	CE0750E4CCE	

① See **Pages 44-54** and **44-55** for Wiring Diagrams.

**Note:** Transformers are designed to operate in a maximum ambient of 40°C.

**Note:** Contact your local Eaton sales office for availability on additional CE Marked control transformers.

For other ratings or styles not shown, refer to Eaton.

Discount Symbol ..... DT-1

**Table 44-64. Type MTE CE Marked IP00**

VA	Dimensions (Inches)			Weight Lbs.	Dimensions (mm)			Weight kg	Wiring Diagram ①	Style Number	Price U.S. \$
	Height	Width	Depth		Height	Width	Depth				
<b>Primary: 380/400/415</b>											
<b>Secondary: 110 x 220 with Jumpers</b>											
50	3	3	3-3/8	3.5	76	76	86	1.6	6	CE0050E4DCE	
75	3-1/2	3-3/8	3-3/8	4.8	89	86	86	2.2	6	CE0075E4DCE	
100	3-1/2	3-3/4	3-3/8	5.9	89	95	86	2.7	6	CE0100E4DCE	
150	4	4-1/2	3-3/4	8.5	102	114	95	3.9	6	CE0150E4DCE	
200	4	4-1/2	3-3/4	10.6	102	114	95	4.8	6	CE0200E4DCE	
250	4	4-1/2	4	11.3	102	114	102	5.1	6	CE0250E4DCE	
300	4	4-1/2	4-3/8	13.2	102	114	111	6.0	6	CE0300E4DCE	
350	4	4-1/2	4-3/4	15.2	102	114	121	6.9	6	CE0350E4DCE	
500	4-1/2	5-1/4	5-1/8	21.0	114	133	130	9.5	6	CE0500E4DCE	
750	4-1/2	5-1/4	7	29.8	114	133	178	13.5	6	CE0750E4DCE	

**Primary: 200/220/440, 208/230/460, 240/480**

**Secondary: 23/110, 24/115, 25/120**

50	3-1/4	3-3/8	3-3/8	4.2	83	86	86	1.9	7	CE0050E5ECE	
75	3-1/2	3-3/4	3-3/8	5.9	89	95	86	2.7	7	CE0075E5ECE	
100	3-1/2	3-3/4	3-5/8	7.9	89	95	92	3.6	7	CE0100E5ECE	
150	4	4-1/2	3-3/4	10.0	102	114	95	4.5	7	CE0150E5ECE	
200	4	4-1/2	4-3/8	12.8	102	114	111	5.8	7	CE0200E5ECE	
250	4	4-1/2	4-3/4	15.2	102	114	121	6.9	7	CE0250E5ECE	
300	4-1/2	5-1/4	4-7/8	16.8	114	133	124	7.6	7	CE0300E5ECE	
350	4-1/2	5-1/4	4-7/8	19.2	114	133	124	8.7	7	CE0350E5ECE	
500	4-1/2	5-1/4	5-5/8	27.0	114	133	143	12.3	7	CE0500E5ECE	

① See Pages 44-54 and 44-55 for Wiring Diagrams.

**Note:** Transformers are designed to operate in a maximum ambient of 40°C.

**Note:** Contact your local Eaton sales office for availability on additional CE Marked control transformers.

For other ratings or styles not shown, refer to Eaton.

Discount Symbol ..... DT-1

CE Marked

Factory Mounted Finger-Safe Terminal Covers



Terminal Type A



Terminal Type B



Terminal Type C

Table 44-65. Type MTK CE Marked with Factory Mounted Finger-Safe Terminal Covers IP20

VA	Dimensions (Inches)			Weight Lbs.	Dimensions (mm)			Weight kg	Terminal Type	Wiring Diagram ①	Style Number	Price U.S. \$
	Height	Width	Depth		Height	Width	Depth					

Primary: 240 x 480, 230 x 460, 220 x 440 with Jumpers

Secondary: 120/115/110

250	4	4-1/2	4-5/16	8.8	102	114	110	4.0	A	1	CE0250K2ACEFS	
300	4	4-1/2	4-7/8	11.0	102	114	124	5.0	A	1	CE0300K2ACEFS	
350	4	4-1/2	5-3/16	11.2	102	114	132	5.1	A	1	CE0350K2ACEFS	
500	4	4-1/2	5-5/8	14.8	102	114	143	6.7	A	1	CE0500K2ACEFS	
750	4-1/2	5-1/4	5-15/16	18.0	114	133	151	8.2	A	1	CE0750K2ACEFS	
1000	5-1/2	6-3/8	6-5/8	26.3	140	162	168	11.9	A	1	CE1000K2ACEFS	
1500	6	6-3/4	7-5/16	40.0	152	172	186	18.1	C	1	CE1500K2ACEFS	
2000	6	6-3/4	8-1/8	45.1	152	172	203	20.5	C	1	CE2000K2ACEFS	
3000	8	9	8-1/16	65.2	200	229	202	29.6	C	1	CE3000K2ACEFS	
5000	8	9	10	104.8	200	229	250	47.5	C	1	CE5000K2ACEFS	

Primary: 240 x 480 with Jumpers

Secondary: 24

250	5-5/8	4-1/2	3-1/4	8.2	143	114	83	3.7	C	2	CE0250K2BCEFS	
300	5-5/8	4-1/2	3-5/8	9.5	143	114	92	4.3	C	2	CE0300K2BCEFS	
350	5-5/8	4-1/2	4-3/16	12.2	143	114	106	5.5	C	2	CE0350K2BCEFS	
500	5-5/8	4-1/2	4-11/16	14.4	143	114	119	6.5	C	2	CE0500K2BCEFS	
750	6-1/2	5-1/4	5-15/16	19.5	165	133	151	8.9	C	2	CE0750K2BCEFS	
1000	6	6-3/8	7	26.2	152	162	178	11.9	C	2	CE1000K2BCEFS	

Primary: 120 x 240 with Jumpers

Secondary: 24

250	5-5/8	4-1/2	3-1/4	8.3	143	114	83	3.8	C	3	CE0250K1BCEFS	
300	5-5/8	4-1/2	3-5/8	9.3	143	114	92	4.2	C	3	CE0300K1BCEFS	
350	5-5/8	4-1/2	4-3/16	12.0	143	114	106	5.4	C	3	CE0350K1BCEFS	
500	5-5/8	4-1/2	4-13/16	14.4	143	114	122	6.5	C	3	CE0500K1BCEFS	
750	6-1/2	5-1/4	5-15/16	19.5	165	133	151	8.9	C	3	CE0750K1BCEFS	
1000	6	6-3/8	7	25.2	152	162	178	11.4	C	3	CE1000K1BCEFS	

Primary: 200/220/440, 208/230/460, 240/480

Secondary: 23/110, 24/115, 25/120

250	3-7/8	4-1/2	4-7/16	12.5	98	114	113	5.7	B	7	CE0250K5ECEFS	
300	3-7/8	4-1/2	4-3/4	14.0	98	114	121	6.3	B	7	CE0300K5ECEFS	
350	3-7/8	4-1/2	5-3/16	15.3	98	114	140	6.9	B	7	CE0350K5ECEFS	
500	5-1/16	5-1/4	6-1/4	20.8	129	133	159	9.4	B	7	CE0500K5ECEFS	
750	7-3/16	6-3/8	5-13/16	29.8	183	162	148	13.5	C	7	CE0750K5ECEFS	
1000	6	6-3/8	7-1/16	30.2	152	162	179	13.7	C	7	CE1000K5ECEFS	

Primary: 220/380/440/550, 230/400/460/575, 240/416/480/600

Secondary: 23/110, 24/115, 25/120

250	3 7/8	4 1/2	5 3/8	14.3	98	114	137	6.5	B	14	CE0250K2UCEFS	
300	3-7/8	4-1/2	5-11/16	15.8	98	114	144	7.2	B	14	CE0300K2UCEFS	
350	4-7/16	5-1/4	5-1/2	16.5	113	133	140	7.5	B	14	CE0350K2UCEFS	
500	5-1/16	5-1/4	6-3/16	20.5	129	133	157	9.3	B	14	CE0500K2UCEFS	
750	7-3/16	6-3/8	5-11/16	28.8	183	162	144	13.1	C	14	CE0750K2UCEFS	
1000	6	6-3/8	8-1/8	39.4	152	162	207	17.9	C	14	CE1000K2UCEFS	

① See Pages 44-54 and 44-55 for Wiring Diagrams.

Note: For additional information, refer to the Cutler-Hammer Industrial Control Transformer Binder B1228A.

Note: Contact your local Eaton sales office for availability on additional CE Marked control transformers.

Discount Symbol ..... DT-1

**Table 44-66. Type MTK CE Marked with Factory Mounted Finger-Safe Terminal Covers IP20**

VA	Dimensions (Inches)			Weight Lbs.	Dimensions (mm)			Weight kg	Terminal Type	Wiring Diagram ①	Style Number	Pricing U.S. \$
	Height	Width	Depth		Height	Width	Depth					
<b>Primary: 208/230/400/460/575</b>												
<b>Secondary: 24 ②/115/230</b>												
250	3-7/8	4-1/2	5-1/2	14.9	98	114	140	6.8	B	15	CE0250K2VCEFS	
300	3-7/8	4-1/2	6-1/16	17.4	98	114	154	7.9	B	15	CE0300K2VCEFS	
350	4-7/16	5-1/4	5-3/4	17.8	113	133	146	8.1	B	15	CE0350K2VCEFS	
500	4-7/16	5-1/4	7-5/16	26.6	113	133	186	12.1	B	15	CE0500K2VCEFS	
750	5-15/16	6-3/8	6-3/16	32.5	151	162	157	14.7	B	15	CE0750K2VCEFS	
1000	6-1/4	6-3/4	7-3/4	44.0	159	172	199	20.0	C	15	CE1000K2VCEFS	
1500	6	6-3/4	7-3/4	45.4	152	172	199	20.6	C	16	CE1500K2WCEFS	
2000	7-5/8	9	7-5/8	58.6	194	229	194	26.6	C	16	CE2000K2WCEFS	
3000	7-5/8	9	8-3/4	92.9	194	229	222	42.1	C	16	CE3000K2WCEFS	
5000	7-5/8	9	10-7/16	127.4	194	229	265	57.8	C	16	CE5000K2WCEFS	
<b>Primary: 240/416/480/600, 230/400/460/575, 220/380/440/550, 208/500</b>												
<b>Secondary: 99/120/130, 95/115/125, 91/110/120, 85/100/110</b>												
250	4	4-1/2	5-1/16	11.4	102	114	135	5.2	A	8	CE0250K6UCEFS	
300	4	4-1/2	5-1/2	13.6	102	114	140	6.2	A	8	CE0300K6UCEFS	
350	4	4-1/2	5-1/2	14.2	102	114	140	6.4	A	8	CE0350K6UCEFS	
500	4-1/2	5-1/4	5-5/8	17.4	114	133	143	7.9	A	8	CE0500K6UCEFS	
750	4-1/2	5-1/4	5-5/8	27.5	114	133	187	12.5	A	8	CE0750K6UCEFS	
1000	5-1/2	6-3/8	7	27.9	140	162	178	12.6	A	8	CE1000K6UCEFS	
1500	6	6-3/4	7-3/4	43.1	152	172	199	19.5	A	8	CE1500K6UCEFS	
2000	8	9	7-5/8	56.0	203	229	194	25.4	B	8	CE2000K6UCEFS	
3000	7-5/8	9	8-9/16	76.2	194	229	217	34.6	B	8	CE3000K6UCEFS	

① See Pages 44-54 and 44-55 for Wiring Diagrams.

② 24 volt secondary only available through 1000 VA.

**Note:** For additional information, refer to the Cutler-Hammer Industrial Control Transformer Binder B1228A.

**Note:** Contact your local Eaton sales office for availability on additional CE Marked control transformers.

CE Marked

Table 44-67. Acceptable Rating of Primary Overcurrent Protection for CE Marked Control Transformers

Fuses 10 x 38 mm (13/32" x 1-1/2") Time-lag (IEC 269)										
Sec. Voltage	50	75	100	150	200	250	300	350	500	750
115	2.0	2.0	4.0	4.0	6.0	6.0	8.0	10.0	12.0	20.0
120	2.0	2.0	4.0	4.0	6.0	6.0	8.0	10.0	12.0	20.0
200	1.0	2.0	2.0	4.0	4.0	4.0	4.0	6.0	8.0	12.0
208	1.0	2.0	2.0	4.0	4.0	4.0	4.0	6.0	8.0	12.0
220	1.0	1.0	2.0	4.0	4.0	4.0	4.0	6.0	6.0	10.0
230	1.0	1.0	2.0	4.0	4.0	4.0	4.0	6.0	6.0	10.0
240	1.0	1.0	2.0	4.0	4.0	4.0	4.0	4.0	6.0	10.0
277	.5	1.0	1.0	2.0	4.0	4.0	4.0	4.0	6.0	8.0
380	.5	1.0	1.0	2.0	2.0	4.0	4.0	4.0	6.0	6.0
400	.5	.5	1.0	2.0	2.0	4.0	4.0	4.0	4.0	6.0
415	.5	.5	1.0	1.0	2.0	4.0	4.0	4.0	4.0	6.0
440	.5	.5	1.0	1.0	2.0	2.0	4.0	4.0	4.0	6.0
460	.5	.5	1.0	1.0	2.0	2.0	4.0	4.0	4.0	6.0
480	.5	.5	.5	1.0	2.0	2.0	4.0	4.0	4.0	6.0
550	.5	.5	.5	1.0	1.0	2.0	2.0	4.0	4.0	4.0
575	.5	.5	.5	1.0	1.0	2.0	2.0	4.0	4.0	4.0
600	.5	.5	.5	1.0	2.0	2.0	2.0	4.0	4.0	4.0

Table 44-68. Acceptable Maximum Rating of Secondary Overcurrent Protection

Miniature Fuses 5 x 20 mm Time-lag (IEC 127-2/III)										
Sec. Voltage	50	75	100	150	200	250	300	350	500	750
23	2.50	4.00	5.00	8.00	10.0	12.00	16.00	16.00	25.00	—
24	2.50	4.00	5.00	8.00	10.0	12.00	16.00	16.00	25.00	32.00
25	2.50	4.00	5.00	8.00	10.0	12.00	16.00	16.00	25.00	32.00
90	.63	1.00	1.25	2.00	2.50	3.15	4.00	4.00	6.30	10.00
95	.63	.80	1.25	1.60	2.50	3.15	4.00	4.00	6.30	8.00
100	.50	.80	1.00	1.60	2.00	2.50	3.15	4.00	5.00	8.00
110	.50	.80	1.00	1.60	2.00	2.50	3.15	4.00	5.00	8.00
115	.50	.80	1.00	1.60	2.00	2.50	3.15	3.15	5.00	8.00
120	.50	.63	1.00	1.25	2.00	2.50	2.50	3.15	5.00	6.30
220	.25	.40	.50	.80	1.00	1.25	1.60	1.60	2.50	4.00
230	.25	.40	.50	.80	1.00	1.25	1.60	1.60	2.50	4.00
240	.25	.315	.50	.63	1.00	1.25	1.25	1.60	2.50	3.15

Note: For values over 6.3A use 10 x 38 mm time-lag (IEC - 269-3-1).  $T_a = 40^\circ\text{C}$  Control Type.

**Type AP**

**Type AP**



*Type AP Transformer*

**Product Description**

- Sand and Resin encapsulated designs.

**Application Description**

Transformers provide stepped down voltages to machine tool control devices enabling control circuits to be isolated from all power and lighting circuits. This allows the use of grounded or ungrounded circuits that are independent of the power or lighting grounds; greater safety is afforded the operator. The control transformer line is particularly adaptable on applications where compact construction is demanded.

**Features, Benefits and Functions**

- UL recognized.
- Resin encapsulated.
- 60 Hz operation.
- 115°C winding rise.
- Convenient screw-type terminal board.
- Bottom or side/wall mounting designs.
- Performance meets/exceeds requirements of ANSI/NEMA ST-1.
- Regulation exceeds ANSI/NEMA requirements for all ratings.

**Standards and Certifications**

**Industry Standards**

All Cutler-Hammer dry-type distribution and control transformers by Eaton Corporation are built and tested in accordance with applicable NEMA, ANSI and IEEE Standards.

**Product Specifications**

**Overload Capability**

Short-term overload is designed into transformers as required by ANSI. dry-type distribution transformers will deliver 200% nameplate load for one-half hour; 150% load for one-hour; and 125% load for four-hours without being damaged provided that a constant 50% load precedes and follows the overload. See ANSI C57.96-01.250 for additional limitations.

Continuous overload capacity is not deliberately designed into a transformer because the design objective is to be within the allowed winding temperature rise with nameplate loading.

**Insulation System and Temperature Rise**

Industry standards classify insulation systems and rise as shown below:

**Table 44-69. Insulation System Classification**

Ambient	+ Winding Rise	+ Hot Spot	= Temp. Class
40°C	55°C	10°C	105°C
40°C	80°C	30°C	150°C
40°C	115°C	30°C	185°C
40°C	150°C	30°C	220°C

The design life of transformers having different insulation systems is the same — the lower temperature systems are designed for the same life as the higher temperature systems.

**Sound Levels**

All Cutler-Hammer 600 volt class general purpose dry-type distribution transformers are designed to meet NEMA ST-20 levels.

**Winding Terminations**

Eaton recommends external cables be rated 90°C (sized at 75°C ampacity) for encapsulated designs.

**Series-Multiple Windings**

Series-multiple windings consist of 2 similar coils in each winding which can be connected in series or parallel (multiple). Transformers with series-multiple windings are designated with an "X" or "/" between the voltage ratings, such as voltages of "120/240" or "240 X 480." If the series-multiple winding is designated by an "X," the winding can be connected only for a series or parallel. With the "/" designation, a mid-point also becomes available in addition to the series or parallel connection. As an example, a 120 X 240 winding can be connected for either 120 (parallel) or 240 (series), but a 120/240 winding can be connected for 120 (parallel), or 240 (series), or 240 with a 120 mid-point.

## Type AP

## Product Selection

Additional Product Selection information begins on **Page 44-63**.

Table 44-70. Type AP

kVA	Mounting	Dimensions (Inches)			Weight Lbs.	Dimensions (mm)			Weight kg	Frame	Wiring Diagram ①	Style Number	Price U.S. \$
		Height	Width	Depth		Height	Width	Depth					
<b>240/480 Volts to 120/240 Volts, 60 Hz</b>													
3	Bottom	8-5/16	9-9/16	8-13/16	65	227	243	224	29.5	FR133	5	C0003P7GB	
5	Bottom	10-3/4	10-3/4	8-11/16	104	273	273	221	47.2	FR99	5	C0005P7GB	
7.5	Bottom	10-3/4	10-3/4	10-3/16	129	273	273	259	58.6	FR100	5	C0007P7GB	
10	Bottom	10-3/4	10-3/4	11-3/8	148	273	273	289	67.2	FR101	5	C0010P7GB	
15	Bottom	12	13-3/16	10-7/16	197	305	335	265	89.4	FR134	5	C0015P7GB	
3	Side/Wall	9-3/4	8-13/16	9-9/16	65	248	224	243	29.5	FR292	5	C0003P7GS	
5	Side/Wall	11-5/8	8-11/16	10-3/4	104	295	221	273	47.2	FR256	5	C0005P7GS	
7.5	Side/Wall	11-5/8	10-13/16	10-3/4	129	295	275	273	58.6	FR257	5	C0007P7GS	
10	Side/Wall	11-5/8	11-3/8	10-3/4	148	295	289	273	67.2	FR258	5	C0010P7GS	
15	Side/Wall	12-7/8	10-7/16	13-3/16	197	327	265	335	89.4	FR259	5	C0015P7GS	

① See **Page 44-34** for Wiring Diagrams.**Note:** For additional information, refer to the Cutler-Hammer Industrial Control Transformer Binder B1228A.

For other ratings or styles not shown, or for special enclosure types (including stainless steel), refer to Eaton.

Discount Symbol ..... DT-1

### Product Selection

#### Single-Phase Transformers

##### How to Select Single-Phase Units

- Determine the primary (source) voltage — the voltage presently available.
- Determine the secondary (load) voltage — the voltage needed at the load.
- Determine the kVA load:  
— If the load is defined in kVA, a transformer can be selected from the tabulated data.

— If the load rating is given in amperes, determine the load kVA from the below chart. To determine kVA when volts and amperes are known, use the formula:

$$\text{kVA} = \frac{\text{Volts} \times \text{Amperes}}{1000}$$

— If the load is an ac motor, determine the minimum transformer kVA from the chart at the right.

— Select a transformer rating equal to or greater than the load kVA.

- Define tap arrangements needed.
- Define temperature rise.

Using the above procedure, select the transformer from the listings in this catalog.

Table 44-71. Single-Phase ac Motors

Horsepower	Full Load Amperes				Minimum Transformer kVA ①
	115 Volts	208 Volts	220 Volts	230 Volts	
1/6	4.4	2.4	2.3	2.2	.53
1/4	5.8	3.2	3.0	2.9	.70
1/3	7.2	4.0	3.8	3.6	.87
1/2	9.8	5.4	5.1	4.9	1.18
3/4	13.8	7.6	7.2	6.9	1.66
1	16	8.8	8.4	8	1.92
1-1/2	20	11.0	10.4	10	2.40
2	24	13.2	12.5	12	2.88
3	34	18.7	17.8	17	4.10
5	56	30.8	29.3	28	6.72
7-1/2	80	44	42	40	9.6
10	100	55	52	50	12.0

① If motors are started more than once per hour, increase minimum transformer kVA by 20%.

**Note:** When motor service factor is greater than 1, increase full load amperes proportionally. Example: If service factor is 1.15, increase above ampere values by 15%.

Table 44-72. Full Load Current in Amperes — Single-Phase Circuits

kVA	Voltage								
	120	208	220	240	277	480	600	2400	4160
.25	2.0	1.2	1.1	1.0	.9	.5	.4	.10	.06
.50	4.2	2.4	2.3	2.1	1.8	1.0	.8	.21	.12
.75	6.3	3.6	3.4	3.1	2.7	1.6	1.3	.31	.18
1	8.3	4.8	4.5	4.2	3.6	2.1	1.7	.42	.24
1.5	12.5	7.2	6.8	6.2	5.4	3.1	2.5	.63	.36
2	16.7	9.6	9.1	8.3	7.2	4.2	3.3	.83	.48
3	25	14.4	13.6	12.5	10.8	6.2	5.0	1.2	.72
5	41	24.0	22.7	20.8	18.0	10.4	8.3	2.1	1.2
7.5	62	36	34	31	27	15.6	12.5	3.1	1.8
10	83	48	45	41	36	20.8	16.7	4.2	2.4
15	125	72	68	62	54	31	25	6.2	3.6
25	208	120	114	104	90	52	41	10.4	6.0
37.5	312	180	170	156	135	78	62	15.6	9.0
50	416	240	227	208	180	104	83	20.8	12.0
75	625	360	341	312	270	156	125	31.3	18.0
100	833	480	455	416	361	208	166	41.7	24.0
167	1391	802	759	695	602	347	278	69.6	40.1

### Technical Data and Specifications

## Three-Phase Transformers

### How to Select Three-Phase Units

- Determine the primary (source) voltage — the voltage presently available.
- Determine the secondary (load) voltage — the voltage needed at the load.
- Determine the kVA load:
  - If the load is defined in kVA, a transformer can be selected from the tabulated data.
  - If the load rating is given in amperes, determine the load kVA from the below chart. To determine kVA when volts and amperes are known, use the formula:

$$\text{kVA} = \frac{\text{Volts} \times \text{Amperes} \times 1.732}{1000}$$

— If the load is an ac motor, determine the minimum transformer kVA from the chart at the right.

— Select a transformer rating equal to or greater than the load kVA.

- Define tap arrangements needed.
- Define temperature rise.

Using the above procedure, select the transformer from the listings in this catalog.

Table 44-73. Three-Phase ac Motors

Horsepower	Full Load Amperes					Minimum Transformer kVA <sup>①</sup>
	208 Volts	230 Volts	380 Volts	460 Volts	575 Volts	
1/2	2.2	2.0	1.2	1.0	.8	.9
3/4	3.1	2.8	1.7	1.4	1.1	1.2
1	4.0	3.6	2.2	1.8	1.4	1.5
1-1/2	5.7	5.2	3.1	2.6	2.1	2.1
2	7.5	6.8	4.1	3.4	2.7	2.7
3	10.7	9.6	5.8	4.8	3.9	3.8
5	16.7	15.2	9.2	7.6	6.1	6.3
7-1/2	24	22	14	11	9	9.2
10	31	28	17	14	11	11.2
15	46	42	26	21	17	16.6
20	59	54	33	27	22	21.6
25	75	68	41	34	27	26.6
30	88	80	48	40	32	32.4
40	114	104	63	52	41	43.2
50	143	130	79	65	52	52
60	170	154	93	77	62	64
75	211	192	116	96	77	80
100	273	248	150	124	99	103
125	342	312	189	156	125	130
150	396	360	218	180	144	150
200	528	480	291	240	192	200

<sup>①</sup> If motors are started more than once per hour, increase minimum transformer kVA by 20%.

**Note:** When motor service factor is greater than 1, increase full load amperes proportionally. Example: If service factor is 1.15, increase above ampere values by 15%.





Table 44-74. Full Load Current in Amperes — Three-Phase Circuits

kVA	Voltage						
	208	240	380	480	600	2400	4160
3	8.3	7.2	4.6	3.6	2.9	.72	.42
6	16.6	14.4	9.1	7.2	5.8	1.4	.83
9	25	21.6	13.7	10.8	8.6	2.2	1.2
15	41.7	36.1	22.8	18.0	14.4	3.6	2.1
22.5	62.4	54.1	34.2	27.1	21.6	5.4	3.1
30	83.4	72.3	45.6	36.1	28.9	7.2	4.2
37.5	104	90.3	57.0	45.2	36.1	9.0	5.2
45	124	108	68.4	54.2	43.4	10.8	6.3
50	139	120	76	60.1	48.1	12.0	6.9
75	208	180	114	90	72	18.0	10.4
112.5	312	270	171	135	108	27.1	15.6
150	416	360	228	180	144	36.1	20.8
225	624	541	342	270	216	54.2	31.3
300	832	721	456	360	288	72.2	41.6
500	1387	1202	760	601	481	120	69.4
750	2084	1806	1140	903	723	180	104
1000	2779	2408	1519	1204	963	241	139

**Contents**

<i>Description</i>	<i>Page</i>
<b>Power Supply Selection Guide</b>	
PSG Series .....	44-65
PSS Series .....	44-71
ELC Series .....	44-77
EZ Power Series .....	44-80
Sensor Power Supplies ..	44-81

**Table 44-75. Power Supply Selection Guide**

Power Supply Series					
	PSG	PSS	ELC	EZ Power Series	Sensor Power Supplies
Features	<ul style="list-style-type: none"> <li>■ General purpose 24V DC control</li> <li>■ Rugged metal housing</li> <li>■ DIN-rail mount</li> <li>■ 150% current boost for 1 sec (outrush)</li> <li>■ Single-phase (85 – 264V AC/120 – 375V DC) or 3-phase (320 – 575V AC/450 – 800V DC) inputs</li> <li>■ Class 1, Division 2 qualified (February 2009)</li> <li>■ Conformal coated electronics</li> </ul>	<ul style="list-style-type: none"> <li>■ 24V DC control for high start-up loads</li> <li>■ Peak current surge (boost/outrush) up to 6 times nominal current</li> <li>■ Semi 47 approved</li> <li>■ Long ride-through capability</li> <li>■ Pluggable terminal connections</li> <li>■ Single-phase and 3-phase inputs up to 600V AC</li> </ul>	<ul style="list-style-type: none"> <li>■ Compact, low cost 24V DC control for loads up to 2A</li> <li>■ Plastic enclosure can be DIN-rail or panel mounted</li> <li>■ Class 1, Division 2 qualified</li> <li>■ Single-phase (85 – 264V AC) input</li> </ul>	<ul style="list-style-type: none"> <li>■ Shallow-depth power supplies for 12V DC or 24V DC applications</li> <li>■ Low-power output — up to 1.25A</li> <li>■ EZ Relay styling provides optimal panel aesthetics</li> <li>■ Plastic enclosure can be DIN-rail or panel mounted (with optional kit)</li> <li>■ Class 1, Division 2 qualified</li> <li>■ Single-phase (85 – 264V AC) input</li> </ul>	<ul style="list-style-type: none"> <li>■ 27V DC supplies for tough sensor applications</li> <li>■ Rugged housings with integrated junction box for mounting outside of electrical enclosures</li> <li>■ Advanced diagnostic features</li> </ul>

PSG Series

PSG Series



Product Description

Eaton's PSG Series of power supplies is designed to be a high-performance, high-quality line of products covering a majority of 24V DC control applications. With global certifications, compact size, and an impressive operating temperature range, the PSG series fits a wide variety of applications at a competitive price.

Eight models are offered, from 2.5A up to 20A with both single and 3-phase input voltage models available.

Application Description

The PSG series is a line of general-purpose power supplies for use in a wide variety of industrial control applications. Applications include communication networks, sensors, PLCs, and many other electrical systems.

Each model is equipped with a rugged metal housing, heavy-duty screw terminals, and a variety of protection features, making the PSG one of the most versatile industrial power supply lines on the market.

Features, Benefits and Functions

- Universal input voltages: 85 – 264V AC for single-phase units, 320 – 575V AC for 3-phase units.
- Rugged aluminum housing stands up to harsh environments.
- Current surge (power boost) of 1.5 times nominal current for 1 sec. allows branch protection and powering of high pick-up loads.
- Wide operating temperature range: -20°C to +75°C (derating above 50°C).

- Adjustable DC voltage output.
- LED indicating light for DC OK simplifies troubleshooting.
- Compact size, with common depth and height across all models allows for common panel depths and family consistency.
- MTBF up to 800,000 hours ensures uptime and reliability.
- Heavy duty screw terminals with finger-safe protective cover allow use of ring-lug terminals.
- All-metal DIN-rail mounting hardware.
- Class 1, Division 2 hazardous location rated (February 2009).

Standards and Certifications

- UL/cUL Listed – UL 508.
- CSA Certified (contact Eaton for certification dates and status).
- CE Marked.
- RoHS Compliant.

Product Selection

Table 44-76. Product Selection

Description	Catalog Number	Price U.S. \$
Power Supply – Single-phase 85 – 264V AC input, 24V DC / 2.5A output	PSG60E	
Power Supply – 3-phase 320 – 575V AC input, 24V DC / 2.5A output	PSG60F	
Power Supply – Single-phase 85 – 264V AC input, 24V DC / 5A output	PSG120E	
Power Supply – 3-phase 320 – 575V AC input, 24V DC / 5A output	PSG120F	
Power Supply – Single-phase 85 – 264V AC input, 24V DC / 10A output	PSG240E	
Power Supply – 3-phase 320 – 575V AC input, 24V DC / 10A output	PSG240F	
Power Supply – Single-phase 85 – 264V AC input, 24V DC / 20A output	PSG480E	
Power Supply – 3-phase 320 – 575V AC input, 24V DC / 20A output	PSG480F	

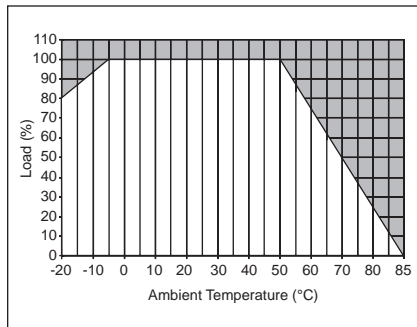

Figure 44-55. Power Derating Curve Vertical Mounting Position PSG60E

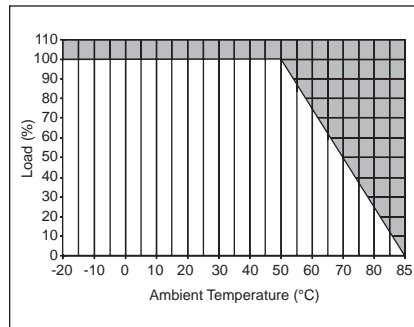

Figure 44-56. Power Derating Curve Vertical Mounting Position PSG60F, PSG120E, PSG120F, PSG480E, PSG480F

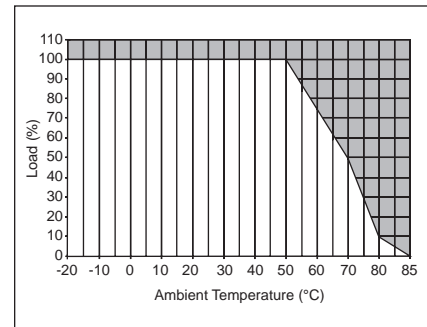

Figure 44-57. Power Derating Curve Vertical Mounting Position PSG240E, PSG240F

Discount Symbol ..... DT-1

## Technical Data and Specifications

**Table 44-77. PSG Technical Specifications**

Capacity	PSG60E	PSG120E	PSG240E	PSG480E	PSG60F	PSG120F	PSG240F	PSG480F
	60W	120W	240W	480W	60W	120W	240W	480W

**Input**

Nominal Voltage	100 – 240V AC				3 x 400 – 500V AC			
Voltage Range	85 – 264V AC (DC input range 120 – 375V DC)				320 – 575V AC (DC input range 450 – 800V DC)			
Frequency	47-63 Hz (0 Hz at DC input)							
Nominal Current <sup>①</sup>	1.1A	1.4A	2.9A	5.7A	0.3A	0.5A	0.8A	1.6A
Inrush Current Limitation <sup>①</sup>	30A	<80A	N/A	N/A	<30A	<30A	<40A	<50A
Mains Buffering @ Nominal Load (Typ.) <sup>①</sup>	>20 ms	>35 ms	>20 ms	>20 ms	>30 ms	>35 ms	>35 ms	>20 ms
Turn-on Time	<2.5 sec	<1 sec	<1 sec	<1 sec	<2 sec	<1 sec	<1 sec	<1 sec
Internal Fuse	T3.15 AH/250V		T6.3AH/250V	F10H/250V	3.15AH/500V			
External Fusing	6A, 10A, or 16A		10A or 16A		3 x circuit breakers 6A, 10A or 16A			
Leakage Current	<1 mA	<1 mA	<3.5 mA	<1 mA	<3.5 mA			

**Output**

Nominal Output Voltage	24V DC +/- 2%							
Adjustment Range	22 – 28V DC							
Nominal Current	2.5A	5A	10A	20A	2.5A	5A	10A	20A
Startup With Capacitive Loads	Max. 8,000 $\mu$ F		Max. 10,000 $\mu$ F					
Max. Power Dissipation Idling/ Nominal Load Approx.	10 W	22.5 W	42.5 W	72 W	9 W	18 W	36 W	72 W
Efficiency (@ 400V AC and Nominal Values)	>85% typ	>84% typ	>84% typ	>86% typ	>86% @ 3 x 400V AC >85% @ 3 x 500V AC		>87% @ 3 x 400V AC >86% @ 3 x 500V AC	
Current Surge (@ 24V DC)	3.75A	7.5A	15A	30A	3.75A	7.5A	15A	30A
Current Surge Time/Cycle	1 second (at 10-second intervals)							
Residual Ripple/Peak Switching (20 Mhz)	<50 mV/<240mVpp							
Parallel Operation	With Oring Diode							

**Galvanic Isolation**

Input/Output	4 kVAC (type test)/3 kVAC (routine test)							
Input/Ground	1.5 kVAC (type test)/1.5 kVAC (routine test)							
Output/Ground	1.5 kVAC (type test)/500V AC (routine test)							

**General/Physical Data**

Housing Material	Aluminum (Al5052)							
Signals	Green LED for DC OK							
MTBF	>800,000 hrs		>300,000 hrs		>500,000 hrs		>300,000 hrs	
Dimensions (L)	121 mm							
Dimensions (W)	32 mm	50 mm	85 mm	160 mm	70 mm	70 mm	85 mm	160 mm
Dimensions (H)	120 mm	115 mm	118.5 mm	115 mm	118.5 mm	118.5 mm	120.5 mm	115 mm
Weight (kg)	0.37	0.54	1.04	1.8	0.56	0.72	0.77	1.71
Operating Temperature	-20°C to +75°C (>50°C derating)							
Storage Temperature	-25°C to +85°C							
Operating Humidity	<95% RH, non-condensing							
Vibration (Operating)	10 to 150 Hz, 0.35 mm acc. 50 m/s/s, single amplitude (5 G max) for 90 min. in each X, Y, Z direction, in acc. with IEC 68-2-6							
Pollution Degree	2							
Climatic Class	3K3 according to EN 60721							

**Approvals/Certifications**

	UL/cUL Listed-UL508 (Industrial Control Equipment), cURus-UL60950-1, CSA, CE, IEC, EN, German Safety, RoHS							
--	--	--	--	--	--	--	--	--

**Safety & Protection**

Transient Surge Voltage	Varistor							
Surge Voltage Protection Against Internal Surge	Yes							
Safety Class	Class I with ground connection							
Shock	30 G (300 m/s/s) in all directions according to IEC 68-2-27							

<sup>①</sup> Ratings for single-phase models are at 115V AC; 3-phase models are at 400V AC.

Dimensions

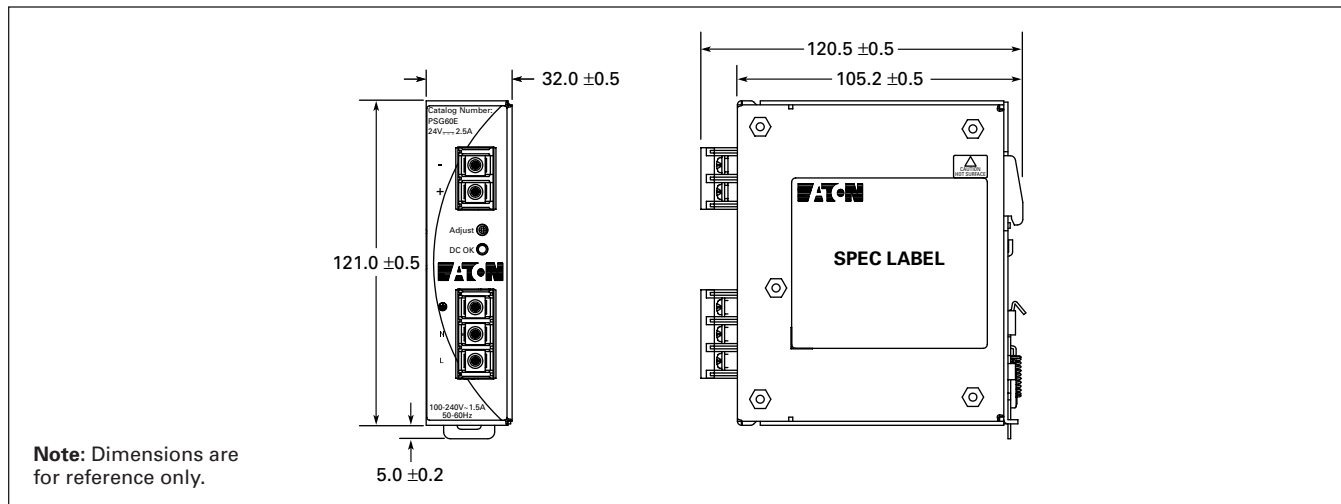

Figure 44-58. PSG60E — Approximate Dimensions in mm

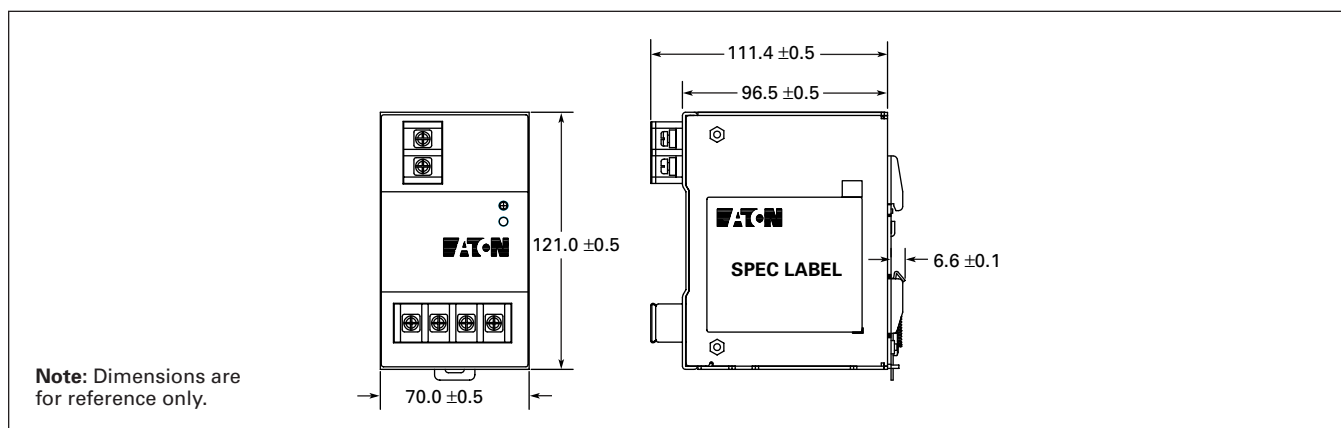

Figure 44-59. PSG60F — Approximate Dimensions in mm

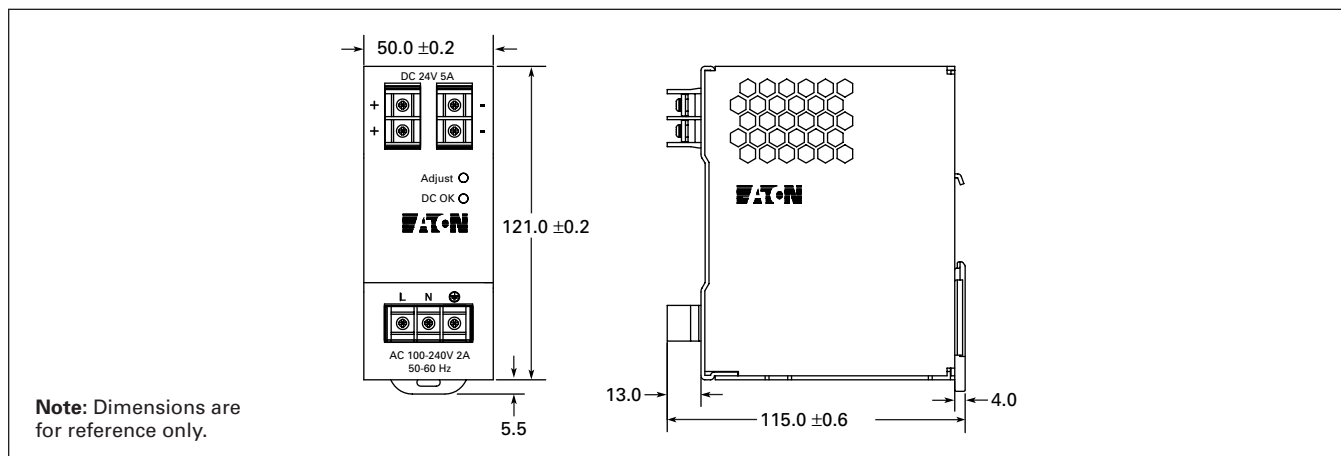
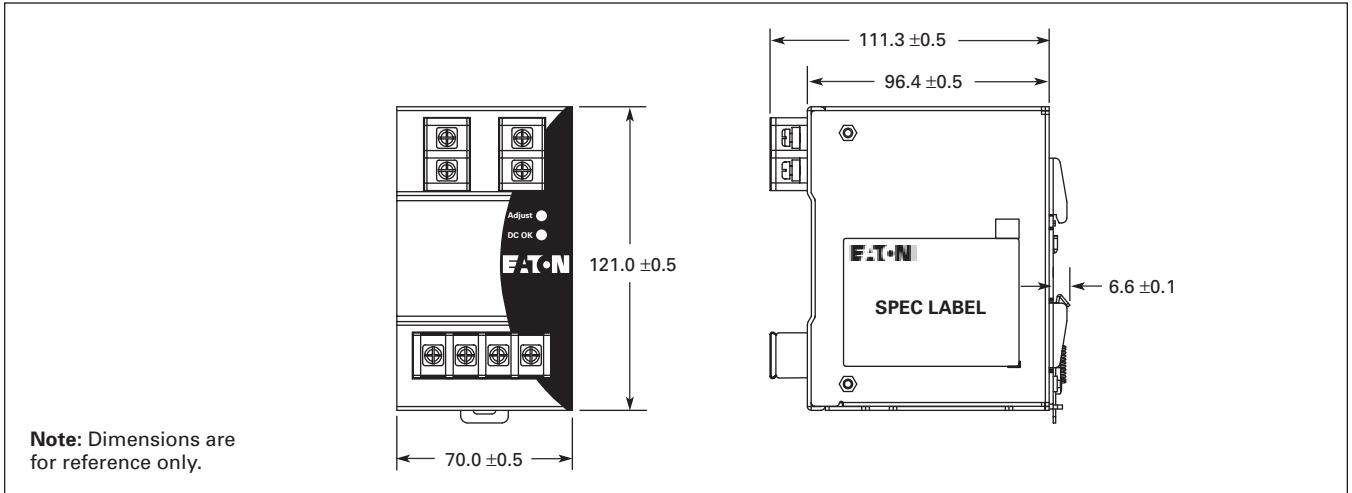
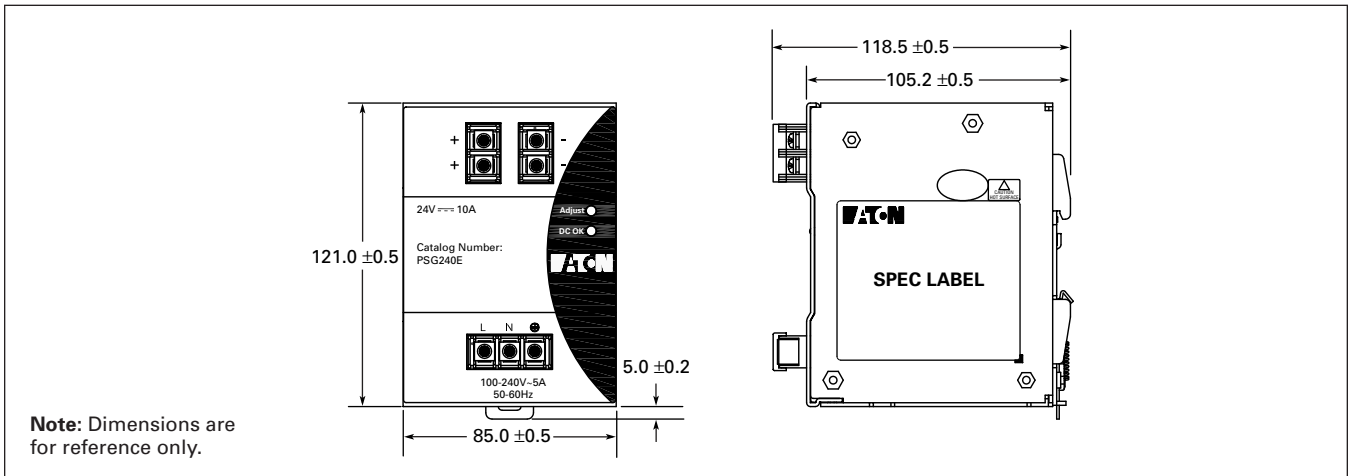

Figure 44-60. PSG120E — Approximate Dimensions in mm

**Dimensions**



**Figure 44-61. PSG120F — Approximate Dimensions in mm**



**Figure 44-62. PSG240E — Approximate Dimensions in mm**

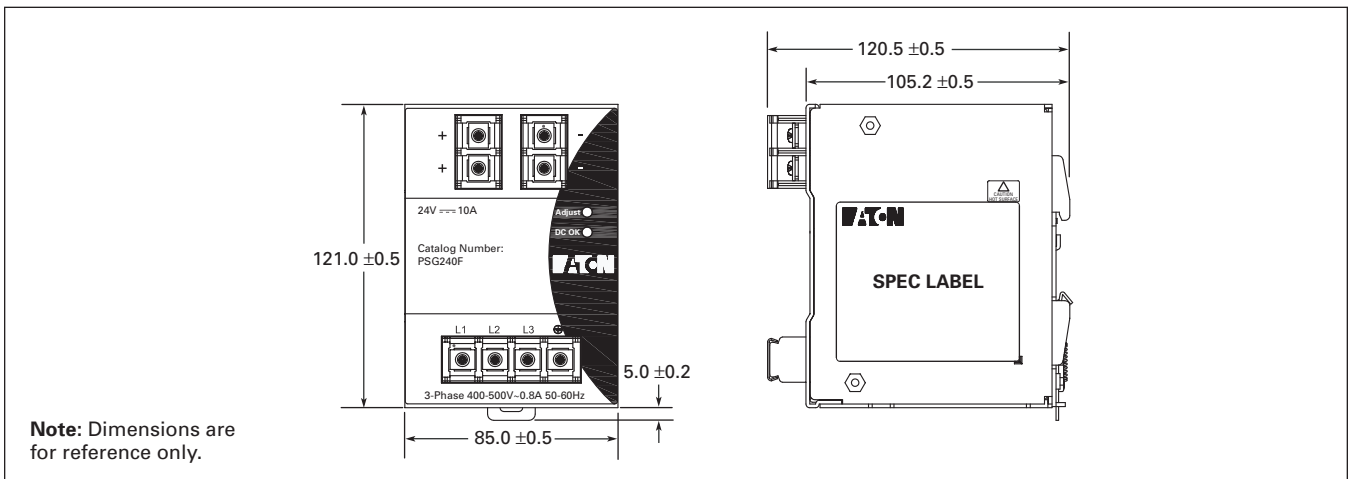

**Figure 44-63. PSG240F — Approximate Dimensions in mm**

Dimensions

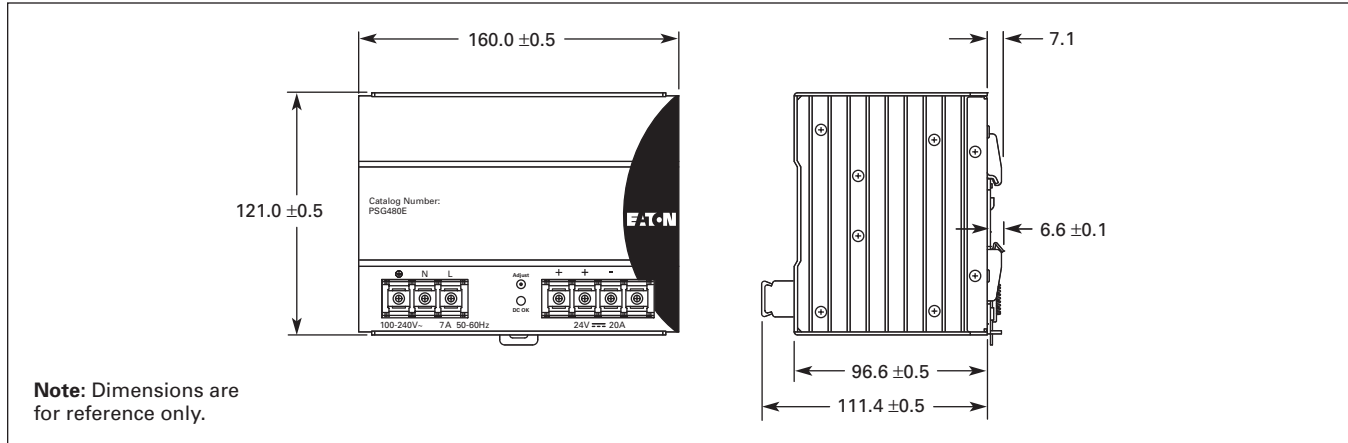

Figure 44-64. PSG480E — Approximate Dimensions in mm

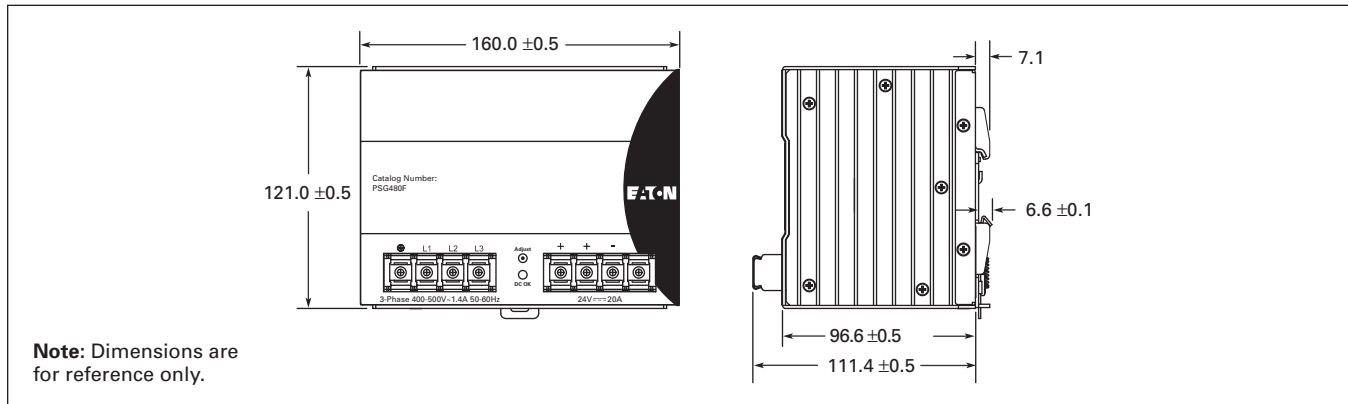

Figure 44-65. PSG480F — Approximate Dimensions in mm

## PSS Series



PSS Supplies

### Product Description

Eaton's PSS Series of power supplies is designed to work in a variety of applications, including the power supply to the *IT* line of power control products. They also work in most control applications that require 24V DC. All of the PSS power supplies are designed to provide the highest "outrush" current in the industry for units of their size. It is also the only line to provide 110 – 480V AC input voltage down to the smallest current units.

### Application Description

The PSS line of power supplies is specifically designed to work with the S801, S811, MV811 and *IT* electro-mechanical devices. They can also serve in a variety of other applications, including support of sensors, operator interfaces, PLCs, communication networks, heaters and lights and in many other industrial applications where 24V DC power supplies are required. With the widest operating temperature range in the industry, rugged design and a long list of advanced features, they can be applied in a very wide range of applications.

The higher input voltage ranges are designed to allow users to eliminate the need for a control power transformer in the enclosure or cabinet, thus saving space, wiring and money.

### Features

- Wide range voltage input (110 – 480V AC operating).
- High current outrush capability in all units.
- Semiconductor F47 approved.
- Long ride-through capability designed in.
- Wide operating temperature range.
- Power supplies can be used in parallel (6.5A and greater).
- Multiple 24V DC terminals for easy wiring.
- DIN-rail and panel mount available in most units.
- Removable terminal connections.
- IP20 fingerproof design.
- Larger units have —
  - Active power factor correction
  - Adjustable output voltages
  - Fault contacts
  - Analog outputs

### Benefits

- 24V DC control enhances personnel and equipment safety.
- IP20 design improves personnel safety.
- Removable terminal connectors make installation and repair quick and easy.
- Wide operating temperature range allows for installation in most areas where standard control products can be installed today.
- High current outrush capability allows use of smaller power supplies in many applications and ensures stable output during high power demand cycles.
- Due to long ride-through time, the Power Supply can maintain the control power system during brown out and black out conditions.

### Standards and Certifications

- UL Listed 508.
- CSA Certified.
- CE Marked.
- F47 Certified.

PSS Series

### Catalog Number Selection

Table 44-78. PSS Catalog Numbering System

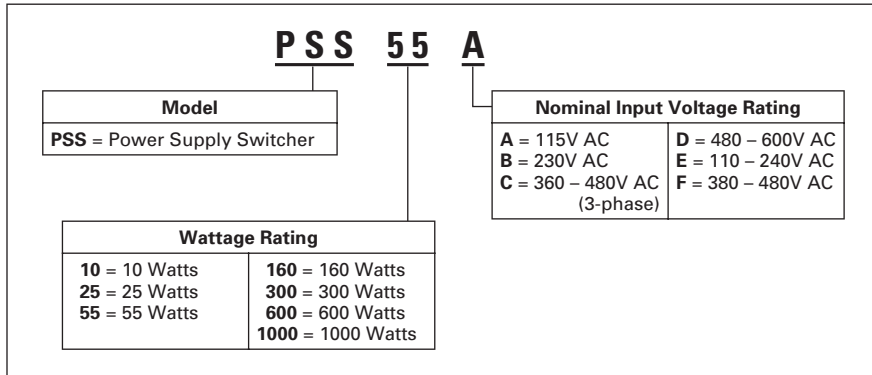

### Accessories

#### DIN-Rail Mounting Kit

Table 44-81. Kits

Description	Catalog Number	Price U.S. \$
DIN-Rail Mounting Kit	PSSDIN	

### Product Selection

Table 44-79. Power Supply Product Selection

Steady State Current (Amps)	Steady State Wattage	Input Voltage	Catalog Number	Price U.S. \$
.4	10W	110 – 240 380 – 480	PSS10E PSS10F	
1.0	25W	110 – 240 380 – 480	PSS25E PSS25F	
2.3	55W	110 – 240 190 – 264 360 – 480 480 – 600	PSS55A PSS55B PSS55C PSS55D	
6.5	160W	110 – 240 380 – 480	PSS160E PSS160C	
12.5	300W	90 – 264 380 – 480	PSS300E PSS300C	
25.0	600W	380 – 480	PSS600C	
40.0	1000W	380 – 480	PSS1000C	

Table 44-80. PSS Sizing Chart

Frame Size	IEC Size	NEMA Size	Steady State Current	Inrush	
				Amps	Durahon
27 mm	A	N/A	.83A	.83A	30 mS
45 mm	B	00, 0	.13A	3.30A	50 mS
54 mm	C	1	.15A	3.80A	50 mS
76 mm	D	2	.21A	5.40A	65 mS
105 mm	E	3, 4	.23A	5.80A	85 mS
140 mm	F	5	.54A	8.30A	250 mS

**PSS Series**

**Technical Data and Specifications**



**Table 44-82. Power Supply Specifications**

Capacity	PSS10E	PSS10F	PSS25E	PSS25F	PSS55A	PSS55B	PSS55C	PSS55D
	10W	10W	25W	25W	55W	55W	55W	55W

**Input**

Voltage	110 to 240V AC	380 to 480V AC	110 to 240V AC	380 to 480V AC	115V AC	230V AC	380 to 480V AC 3-Phase	480 to 600V AC 3-Phase
Input Current (RMS)	.19A	.1A	.45A	.17A	.9A	.54A	.20A/Phase	.07A/Phase
Frequency	47 – 63 Hz	47 – 63 Hz	47 – 63 Hz	47 – 63 Hz	47 – 63 Hz	47 – 63 Hz	47 – 63 Hz	47 – 63 Hz
Voltage Range	± 10%	± 10%	± 10%	± 10%	± 15%	± 15%	± 10%	± 15%
Inrush Current	25A	25A	35A	35A	16A	32A	15A	15A
Overvoltage	330V AC	550V AC	330V AC	550V AC	Varistor	Varistor	Varistor	Varistor
Internal Input Fuse	T2A @ 250V	T2A @ 250V	T4A @ 250V	T2A @ 250V	T2A @ 250V	T2A @ 250V	3 x T2A @ 250V	—
External Fusing	Not Required 2A 250V AC Slow Blow							3 x 1A 600V AC Slow Blow

**Output**

Voltage Nominal	24V DC	24V DC	24V DC	24V DC	24V DC	24V DC	24V DC	24V DC
Voltage Regulation	±10%	±10%	±10%	±10%	±3.5%	±3.5%	±3.5%	±3.5%
Current Nominal	.4A	.4A	1.0A	1.0A	2.3A	2.3A	2.3A	2.3A
Voltage Adj. Range	None	None	None	None	None	None	None	None
Current Surge	1A	1A	6.8A	6.8A	10A	10A	10A	10A
Current Surge Time	35 mS	35 mS	85 mS	85 mS	180 mS	180 mS	180 mS	180 mS
Surge Cycle Time					10 sec	10 sec	10 sec	10 sec
Hold Up Time	100 mS	100 mS	100 mS	100 mS	70 mS	70 mS	24 mS	30 mS
Max. Load Capacitance	10,000 µF	10,000 µF	10,000 µF	10,000 µF	10,000 µF	10,000 µF	10,000 µF	10,000 µF
Switching Frequency	60k Hz	60k Hz	100k Hz	100k Hz	100k Hz	100k Hz	100k Hz	61k Hz
Efficiency @ Max. Load	80%	75%	80%	80%	80%	80%	80%	85%
Output Ripple	±1%	±1%	±1%	±1%	±1%	±1%	±1%	±1%

## PSS Series

Table 44-82. Power Supply Specifications (Continued)

Capacity	PSS10E	PSS10F	PSS25E	PSS25F	PSS55A	PSS55B	PSS55C	PSS55D
	10W	10W	25W	25W	55W	55W	55W	55W
<b>Protection</b>								
Short Circuit	Auto restart	Auto restart	Auto restart	Auto restart	Auto restart	Auto restart	Auto restart	Auto restart
Over Voltage	No	No	No	No	No	No	No	No
Under Voltage	No	No	No	No	No	No	No	No
Over Temperature	None. Software in Micro Controller							
Over Current	0.8A typical @ 24V for >100 mS	0.8A typical @ 24V for >160 mS	6.8 A typical @ 24V for >160 mS	6.8A typical @ 24V for >160 mS	10A typical @ 24V for >300 mS	10A typical @ 24V for >300 mS	10A typical @ 24V for >300 mS	10A typical 24V for >300 mS
<b>Galvanic Isolation</b>								
Input to Output	1.5 kV	2 kV	1.5 kV	2 kV	3 kV	3 kV	3 kV	4 kV
Input/Output to Rail	1.5 kV	2 kV	1.5 kV	2 kV	3 kV	3 kV	3 kV	4 kV
Input to Ground	1.5 kV	2 kV	1.5 kV	2 kV	1.5 kV	1.5 kV	1.5 kV	2.0 kV
Output to Ground	200V	200V	200V	200V	200V	200V	200V	250V
<b>Special Features</b>								
Cooling	Convection	Convection	Convection	Convection	Convection	Convection	Convection	Convection
Load Sharing	None	None	None	None	None	None	None	None
Redundancy	None	None	None	None	None	None	None	None
Analog Outputs	None	None	None	None	None	None	None	None
Fault Relay	None	None	None	None	None	None	None	None
<b>Wire Size</b>								
Input	20 – 14 AWG	20 – 14 AWG	20 – 14 AWG	20 – 14 AWG	20 – 14 AWG	20 – 14 AWG	20 – 14 AWG	20 – 14 AWG
Output	20 – 14 AWG	20 – 14 AWG	20 – 14 AWG	20 – 14 AWG	20 – 14 AWG	20 – 14 AWG	20 – 14 AWG	20 – 14 AWG
I/O	None	None	None	None	None	None	None	None
<b>Indications</b>								
Indicators	Green LED (DC on)							
<b>Physical Data</b>								
Dimensions Length x Width x Depth in inches (mm)	4.49 x 1.97 x 4.49 (114 x 50 x 114)	4.49 x 1.97 x 4.49 (114 x 50 x 114)	4.49 x 1.97 x 4.49 (114 x 50 x 114)	4.49 x 1.97 x 4.49 (114 x 50 x 114)	2.09 x 3.86 x 5.59 (53 x 98 x 142)	2.09 x 3.86 x 5.59 (53 x 98 x 142)	2.32 x 4.21 x 6.73 (59 x 107 x 171)	2.32 x 6.19 x 6 (59 x 157 x 154)
Weight (kg)	.57 (.26)	.64 (.29)	.73 (.33)	.81 (.37)	1.06 (.48)	1.06 (.48)	1.17 (.53)	2.45 (1.1)
Mounting and Recommended Clearance	TS35 rail or chassis; leave 4 in. (10 cm) free space on venting sides.				TS35 Rail (with optional PSSDIN Kit) or Chassis; Leave 4 in. (10 cm) free space on venting sides.			—
<b>Environmental Performance</b>								
Storage Temperature	-25 to 80°C	-25 to 80°C	-25 to 80°C	-25 to 80°C	-40 to 85°C	-40 to 85°C	-40 to 85°C	-40 to 85°C
Operating Temperature	-5 to 50°C	-5 to 50°C	-5 to 50°C	-5 to 50°C	-25 to 50°C	-25 to 50°C	-25 to 50°C	-25 to 50°C
Storage Humidity	5 to 95%	5 to 95%	5 to 95%	5 to 95%	5 to 95%	5 to 95%	5 to 95%	5 to 95%
Operating Humidity	<95% RH non-condensing	<95% RH non-condensing	<95% RH non-condensing	<95% RH non-condensing	20 to 85% non-condensing	20 to 85% non-condensing	20 to 85% non-condensing	20 to 85% non-condensing
<b>Approvals/Certifications</b>								
	UL, IEC, CSA	UL, IEC, CSA	UL, IEC, CSA	UL, IEC, CSA	cULus 1950 Recognized, cULus 508 Listed, CE			cCSAus

**PSS Series**



**PSS160E**



**PSS300E**

**Table 44-82. Power Supply Specifications (Continued)**

Capacity	PSS160E	PSS160C	PSS300E	PSS300C	PSS600C	PSS1000C
	<b>160W</b>	<b>160W</b>	<b>300W</b>	<b>300W</b>	<b>600W</b>	<b>1000W</b>
<b>Input</b>						
Voltage	115 to 230V AC	380 to 480V AC 3-Phase	115 to 230V AC	380 to 480V AC 3-Phase	380 to 480V AC 3-Phase	380 to 480V AC 3-Phase
Input Current (RMS)	2.3A/1.4A	.43A/Phase	3.3A/1.65A	.75A/Phase	1.4A/Phase	1.9A/Phase
Frequency	47 – 63 Hz	47 – 63 Hz	47 – 63 Hz	47 – 63 Hz	47 – 63 Hz	47 – 63 Hz
Voltage Range	± 10%	± 10%	± 10%	± 10%	± 10%	± 10%
Inrush Current	16/32A	5.7A	30A	40A	40A	40A
Over Voltage	Varistor	Varistor	Varistor	Varistor	Varistor	Varistor
Internal Input Fuse	T6.3A @ 250V	3 x T2A @ 500V	T5A @ 250V	No	No	No
External Fusing	Not Required 3A 250V AC Slow Blow	Not Required 2A 480V AC Slow Blow	Not Required 6A 250V AC Slow Blow	3 x T2A @ 480V AC Slow Blow	Required 3 x 6A @ 480V AC Slow Blow	
<b>Output</b>						
Voltage Nominal	24V DC	24V DC	24V DC	24V DC	24V DC	24V DC
Voltage Regulation	±3.5%	±3.5%	±6%	±5%	±6%	±6%
Current Nominal	6.5A	6.5A	12.5A	12.5A	25A	40A
Voltage Adj. Range	22.5 to 28.5V DC	22.5 to 28.5V DC	23 to 28V DC	23 to 28V DC	23 to 28V DC	23 to 28V DC
Current Surge	13A	20A	18A	25A	50A	80A
Current Surge Time	1 sec	1 sec	1 sec	1 sec	1 sec	1 sec
Surge Cycle Time	10 sec	10 sec	10 sec	60 sec	60 sec	60 sec
Hold Up Time	50 mS	15 mS	30 mS	25 mS @ 480V AC	12 mS	>14 mS
Max. Load Capacitance	10,000 µF	10,000 µF	10,000 µF	10,000 µF	10,000 µF	10,000 µF
Switching Frequency	65k Hz	100k Hz	100k Hz	100k Hz	65k Hz	65k Hz
Efficiency @ Max. Load	85%	83%	80%	83%	87%	90%
Output Ripple	±1%	±1%	±.1%	±.1%	±.1%	±.1%

## PSS Series

Table 44-82. Power Supply Specifications (Continued)

Capacity	PSS160E 160W	PSS160C 160W	PSS300E 300W	PSS300C 300W	PSS600C 600W	PSS1000C 1000W
<b>Protection</b>						
Short Circuit	Auto restart	Auto restart	Auto restart	Auto restart	Auto restart	Auto restart
Over Voltage	No	Yes	Yes	Yes	Vout > 30V DC	Vout > 30.5V DC
Under Voltage	No	Yes	Yes	Yes	Vout < 20V DC	Vout < 20V DC
Over Temperature	None. Software in Micro Controller		Vout heatsink temp. is greater than 100°C			
Over Current	13A typical @ 24V for >1 sec	13A typical @ 24V for >1 sec	20A typical @ 24V for >1 sec	20A typical @ 24V for >1 sec	26.5A typical @ 24V for >1 sec	43A typical @ 24V for >1 sec
<b>Galvanic Isolation</b>						
Input to Output	3 kV	3 kV	3 kV	3 kV	3 kV AC	3 kV AC
Input/Output to Rail	3 kV	3 kV	3 kV	3 kV	1.5 kV AC	1.5 kV AC
Input to Ground	1.5 kV	1.5 kV	1.5 kV	1.5 kV	1.5 kV AC	1.5 kV AC
Output to Ground	500V	500V	500V	500V	500V AC	500V AC
<b>Special Features</b>						
Cooling	Convection	Convection	Fan cooled	Convection	Fan cooled	Fan cooled
Load Sharing	Maximum 2 units	Maximum 2 units	Maximum 3 units (active)	Maximum 2 units	Maximum 2 units	Maximum 2 units
Redundancy	Maximum 2 units	Maximum 2 units	Maximum 2 units	Maximum 2 units	Maximum 2 units	Maximum 2 units
Analog Outputs	None	None	VDC Out = 3 x V analog, T = 10 x V analog, IOOUT = 10 x V analog	None	VDC OUT = 3 x V analog, T = 10 x V analog, IOOUT = 10 x V analog	
Fault Relay	Form C, 125V AC and 30V DC @ 1A rating	Form C, 125V AC and 30V DC @ 1A rating	Form C contacts (1A @ 30V DC or 30V AC)	Form C contacts (1A @ 30V DC or 30V AC)	Form C contacts (1A @ 30V DC or 30V AC)	Form C contacts (1A @ 30V DC or 30V AC)
<b>Wire Size</b>						
Input	26 – 12 AWG	26 – 12 AWG	22 – 12 AWG	22 – 12 AWG	22 – 12 AWG	22 – 12 AWG
Output	26 – 12 AWG	26 – 12 AWG	22 – 6 AWG	22 – 6 AWG	22 – 6 AWG	22 – 6 AWG
I/O	26 – 12 AWG	26 – 12 AWG	22 – 12 AWG (.08 – 2.5 mm <sup>2</sup> )	22 – 12 AWG (.08 – 2.5 mm <sup>2</sup> )	22 – 12 AWG (.08 – 2.5 mm <sup>2</sup> )	22 – 12 AWG (.08 – 2.5 mm <sup>2</sup> )
<b>Indications</b>						
Indicators	Green LED (DC on)					
<b>Physical Data</b>						
Dimensions Length x Width x Depth in Inches (mm)	5.0 x 2.2 x 6.8 (127 x 57 x 175)	5.44 x 2.3 x 7 (138.2 x 58.4 x 177.8)	4.1 x 9.53 x 6.1 (104 x 242 x 155)	6.25 x 3.16 x 6.35 (159 x 80 x 161)	6.8 x 9.4 x 5.3 (173 x 238 x 135)	7.2 x 10.6 x 5.3 (182 x 268 x 133)
Weight Lbs. (kg)	1.94 (.88)	2.2 (.99)	2.6 (1.18)	3.0 (1.4)	6.6 (3)	8.35 (3.8)
Mounting and Recommended Clearance	TS35 Rail with optional PSSDIN Kit or Chassis (hardware included); leave 4 in. (10 cm) free space on venting sides.					
<b>Environmental Performance</b>						
Storage Temperature	-40 to +85°C	-40 to +85°C	-40 to +85°C	-40 to +85°C	-40 to +85°C	-40 to +85°C
Operating Temperature	-20 to 50°C	-20 to 50°C	-20 to 50°C	-20 to 50°C	-10 to +50°C (Full Power)	-10 to +50°C (Full Power)
Storage Humidity	5 to 95%	5 to 95%	4 to 95%	4 to 95%	5 to 95%	5 to 95%
Operating Humidity	20 to 85% non- condensing	20 to 85% non- condensing	19 to 85% non- condensing	19 to 85% non- condensing	20 to 85% non- condensing	20 to 85% non- condensing
<b>Approvals/Certifications</b>						
	CE, cULus 508 Listed	CE, cULus 508 Listed	CE, cULus 508 Listed	CE, cULus 508 Listed	CE, cULus 508 Listed	CSA 22.2 #950-95, cULus 508 Listed, CE

**ELC Power Supply**

**ELC Power Supply**



*ELC Power Supply*

**Product Description**

Eaton's ELC power supplies are the perfect products for those applications requiring a very compact and low-cost source for 24V DC power. While these products were developed to be a perfect match for our Eaton Logic Controllers, they can be used in a variety of applications.

The lightweight, DIN-rail mounted enclosures, wide input voltage range, and robust screw terminals make these power supplies easy to install and use. They are available in 1A and 2A models.

**Features, Benefits and Functions**

- Universal input voltage: 85-264V AC.
- Compact size, with common depth and height across models allows for common panel depths and family consistency.
- ELC styling provides maximum aesthetic appeal when used with the Eaton Logic Controllers.

- Front-mounted pressure plate screw terminals for a robust connection.
- Removable finger-safe protective cover for terminals.
- Power On indication LED.
- Integrated mounting hardware for panel mounting or DIN-rail mounting.

**Standards and Certifications**

- UL / cUL Listed – UL 508.
- CE Marked.
- RoHS Compliant.
- Class I, Division II for groups A, B, C, D.

**Product Selection**

**Table 44-83. ELC Product Selection**

Description	Catalog Number	Price U.S. \$
24 Watt, 1 Amp Power Supply	ELC-PS01	
48 Watt, 2 Amp Power Supply	ELC-PS02	

**Technical Data and Specifications**

**Table 44-84. Technical Specifications**

Capacity	ELC-PS01	ELC-PS02
	24W	48W
<b>Input</b>		
Nominal Voltage	100 – 240V AC	
Voltage Range	85 – 264V AC	
Frequency	47 – 63 Hz	
<b>Output</b>		
Nominal Output Voltage	24V DC +/- 3%	
Nominal Current	1 A	2 A
Efficiency	78% to 87% typical at full load	
Residual Ripple/Peak Switching (20 MHz)	< 100 mV typical @ full load	< 240 mV typical @ full load
<b>General/Physical Data</b>		
Housing Material	Plastic	
Dimensions (D)	60 mm	
Dimensions (W)	36.5 mm	55 mm
Dimensions (H)	90 mm	
Weight (g)	158	250
Operating Temperature	0°C to +55°C	
Storage Temperature	-25°C to +70°C	
Operating Humidity	50% to 95% RH, non-condensing	
Pollution Degree	2	
<b>Approvals/Certifications</b>		
	UL508, CE, RoHS, EMC directive 89/336/EEC, Low voltage directive 73/23/EEC	
<b>Safety and Protection</b>		
Overload/Short Circuit Protection	Auto recovery	

ELC Power Supply

Dimensions

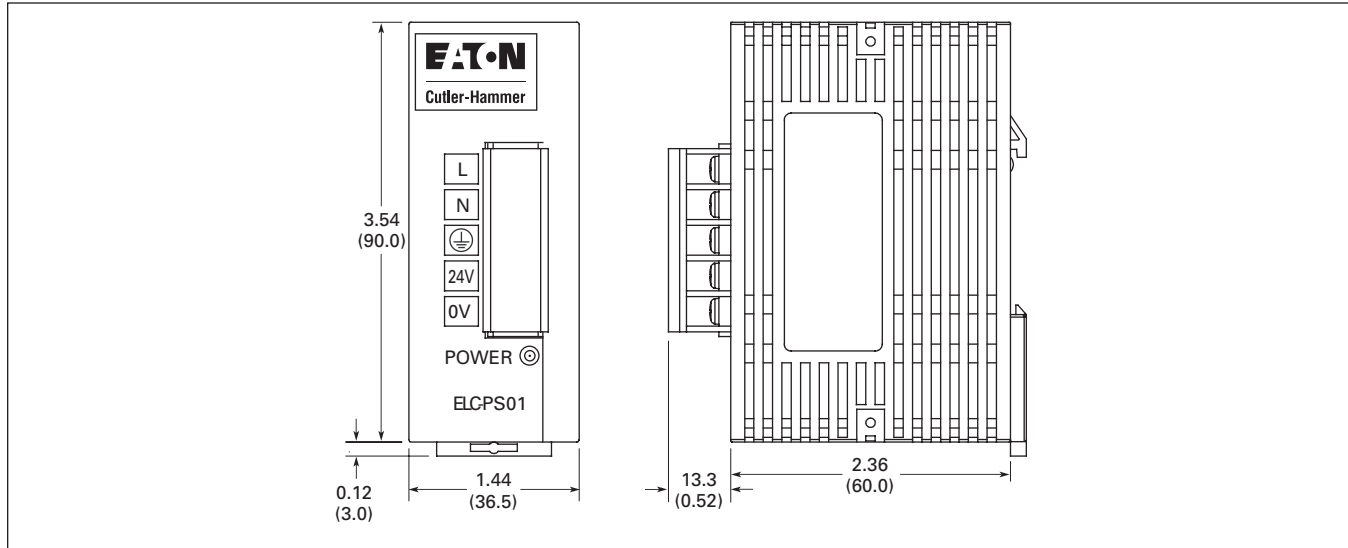

Figure 44-66. ELC-PS01 Power Supply — Approximate Dimensions in Inches (mm)

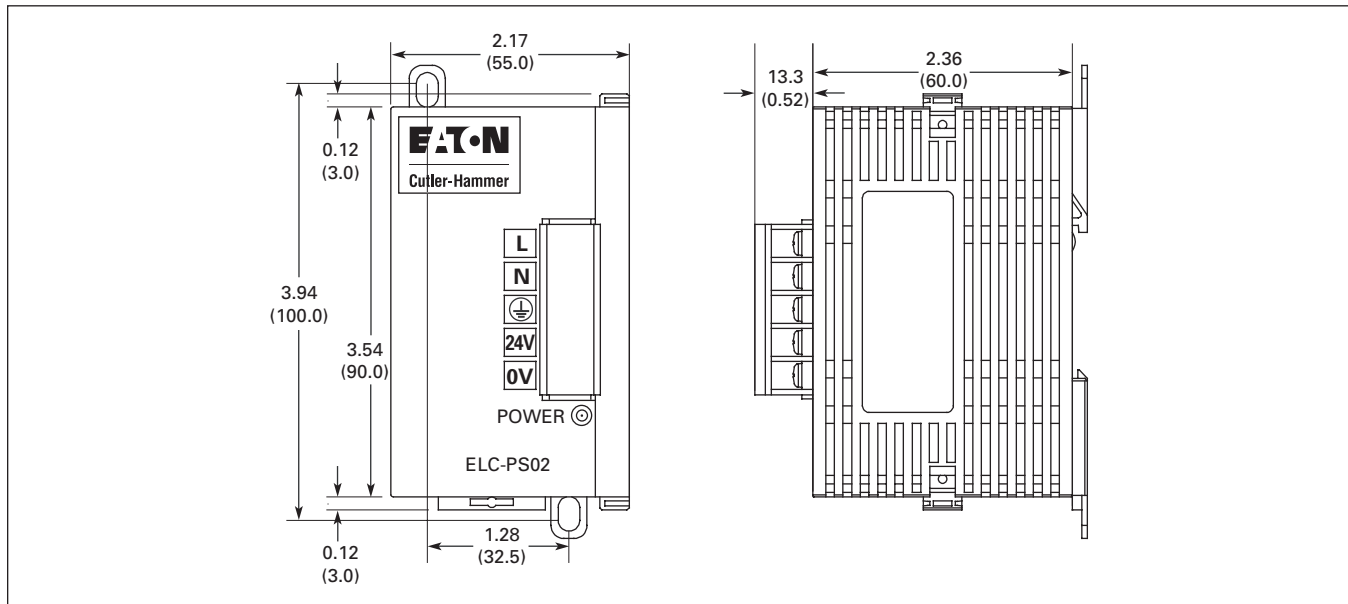

Figure 44-67. ELC-PS02 Power Supply — Approximate Dimensions in Inches (mm)

### EZ Power Supply

## EZ Power Supply



## Product Description

Eaton's EZ power supplies are the perfect products for those applications requiring a low-amperage 24V DC power source. While these products were developed to be a perfect match for our EZ Relay products, they can be used in a variety of applications.

## Features, Benefits and Functions

- Universal input voltage: 85 – 264V AC.
- Compact size, with common depth and height across models allows for common panel depths and family consistency.
- EZ styling provides maximum aesthetic appeal when used with the Eaton EZ Relay products.
- Wide operating temperature range (-25°C to 55°C).
- Power On indication LED.
- Optional mounting hardware for panel mounting (EZB4-101-GF1) or standard DIN-rail mounting.
- Finger-safe, side-entry screw clamp terminals for clean wiring.

## Standards and Certifications

- UL Listed.
- CSA Certified.
- CE Marked.
- Class I, Division II rated for groups A, B, C, D.
- RoHS Compliant.

## Product Selection

Table 44-85. EZ/EZD-CPs Power Supplies

Description	Catalog Number	Price U.S. \$
100 – 240V AC Input to 12V DC at 20 mA/24V DC at 250 mA	EZ200-POW	
100 – 240V AC Input to 24V DC at 1.25A	EZ400-POW	

## Technical Data and Specifications

Table 44-86. Technical Specifications

Capacity	EZ200-POW	EZ400-POW
	6W	30W
<b>Input</b>		
Nominal Voltage	100 – 240V AC	
Voltage Range	85 – 264V AC	
Frequency	47 – 63 Hz	
<b>Output</b>		
Nominal Output Voltage	24V DC +/- 3%	
Nominal Current	.25 A	1.25 A
<b>General/Physical Data</b>		
Housing Material	Plastic	
Dimensions (D)	56.5 mm	
Dimensions (W)	35.5 mm	71.5 mm
Dimensions (H)	90 mm	
Operating Temperature	-25°C to +55°C	
Storage Temperature	-40°C to +70°C	
Pollution Degree	2	
Connection Cables	0.2-4.0 mm <sup>2</sup> (AWG 22-12), Solid 0.2-2.5 mm <sup>2</sup> (AWG 22-12), Flexible	
<b>Approvals/Certifications</b>		
	UL, CE, RoHS, CSA, EN 50178m IEC/EN 60947	
<b>Safety and Protection</b>		
Overload/Short Circuit Protection	Yes	
Over Current Limitation Form	0.3A	1.4A
Degree of Protection	IP20	
RFI Suppression	EN 55011, EN 55022 Class B, IEC 61000-6-1, 2, 3, 4	
Potential Isolation (prim./sec.)	Yes, SELV, (to EN 600950, VDE 805)	

EZ Power Supply

Dimensions

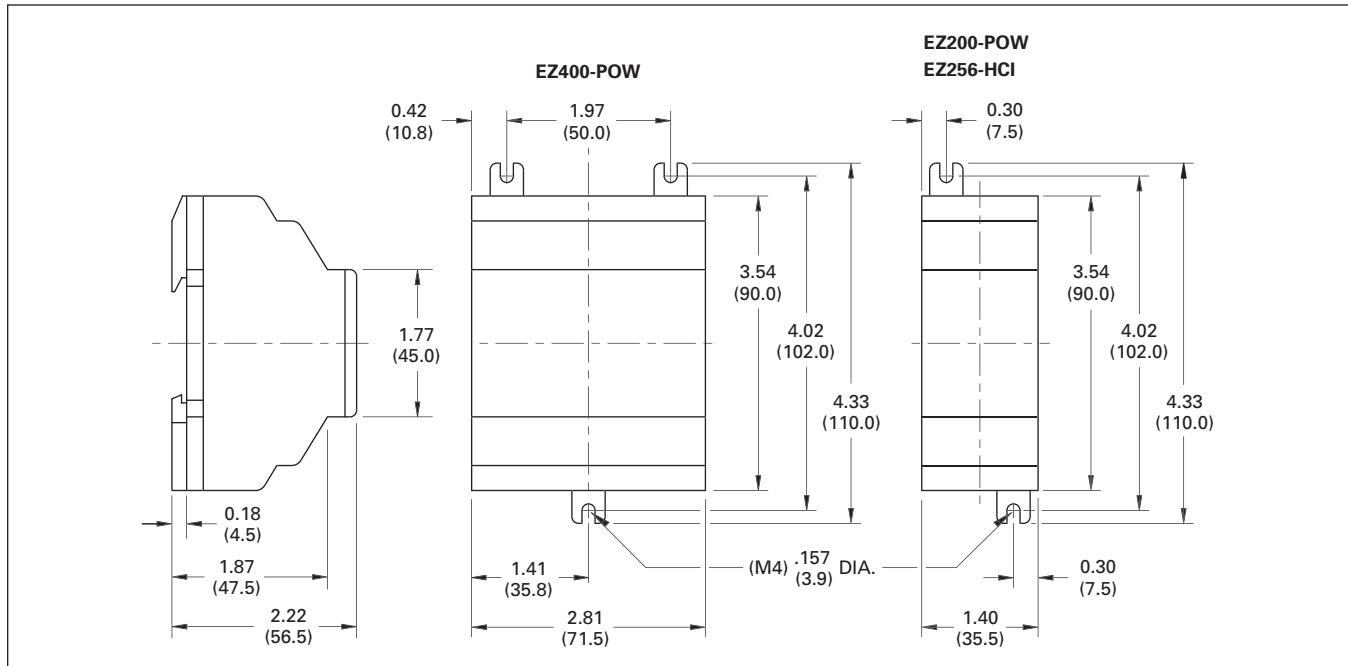

Figure 44-68. EZ200-POW/EZ256-HCI and EZ400-POW Series Dimensions in Inches (mm)

**Sensor Power Supply**

**Sensor Power Supply**



Accumulation Systems, but is also suitable for use in a wide variety of applications. The unit delivers 100W output at 27V DC and supports easy, Class II wiring. The power supply is a tamper-proof, rugged component easily mounted to a conveyor side-channel or support. Internal components are fully encapsulated in a strong die-cast housing to stand up to rugged handling, ensuring flawless performance in any material handling environment.

**Features, Benefits and Functions**

- Integrated AC junction box for one-step mounting and wiring without the need for additional accessories.
- Built-in DC power health contact allows easy monitoring of power supply status.
- Unitized design features a tamper-proof encapsulated construction to reduce the risk of damage associated with conventional open control-panel type construction.

- Built-in slug-release input converts an AC or DC input to the appropriate DC signal for integration with the 200 Series and E68 Series Zero Pressure Accumulation Systems.
- Dual output connection terminals to make it easy and convenient to locate the power supply at the center of the cable run.
- Power switch protected against accidental operation.
- Power in and out indicators show status at a glance.
- Conduit entry box for NEC compliance.
- Simple mounting with two 1/4-inch bolts.
- Rugged die-cast housing.
- Fully encapsulated electronics.

**Standards and Certifications**

- UL Listed.
- CSA Approved.

**Product Description**

The Cutler-Hammer® Sensor Power Supply by Eaton Corporation was specially designed to be used with the 200 Series and E68 Series Zero Pressure

**Product Selection**

**Table 44-87. Model Selection**

Operating Voltage	Output	Slug Input	Type	Slug Output	Catalog Number	Price U.S. \$
105 – 132V AC	27V DC, 100W; short circuit, overload and overvoltage protection (cycle power to reset)	15 – 132V AC/DC 3 mA minimum	Standard For use with 200 series and E68 systems	Sinking or Sourcing, switch selectable; 80 mA maximum; short circuit protection for loads less than 32V AC or DC (auto reset)	PS256A-01B1 ②	
			High Current Slug For use with solenoid valve systems requiring full current slug signals	Sinking only; 100W output; short circuit, overload and overvoltage protection (cycle power to reset) ①	PS256A-04B1 ②	

① Total output power of supply is 100W. Total supply output power (100W) = main output power + slug output power.

② Stocked product, typical order quantities guaranteed in stock.

## Sensor Power Supply

## Technical Data and Specifications

Table 44-88. Sensor Power Supply Specifications

Description	PS256A-01B1	PS256A-04B1
Input Power	144W, Maximum inrush 30A from cold start	
Input Voltage	105 – 132V AC	
Input Current (Full Load)	105V AC – 1.92A, 115V AC – 1.65A, 132V AC – 1.5A	
Output Power	100W	
Output Voltage	27V DC	
Output Protection	Short circuit, overload and overvoltage protection (cycle power to reset), diode protected	
Regulation	±3%	
Slug Input	15 – 132V AC/DC	
Slug Output	Sinking or Sourcing, switch selectable; 80 mA maximum; short circuit protection for loads less than 32V AC or DC (auto reset)	Sinking only; 100W output; short circuit, overload and overvoltage protection (cycle power to reset) <sup>①</sup>
Indicators	Red LED: AC In; Green LED: DC Out	
DC Fail Indication Output	N.O. contact, solid-state relay, 80 mA maximum	
Temperature Range	-13° to 131°F (-25° to 55°C)	
Vibration	20g	
Enclosure Material	Die-cast aluminum	
Enclosure Rating	NEMA 1	
Connections	Main Output/Slug Output: Two three-position finger protected barrier strips; AC Line Input, DC Fail Indication and Slug Input: 8-position screw terminal strip inside conduit entry box	

<sup>①</sup> Total output power of supply is 100W. Total supply output power (100W) = main output power + slug output power.

## Dimensions

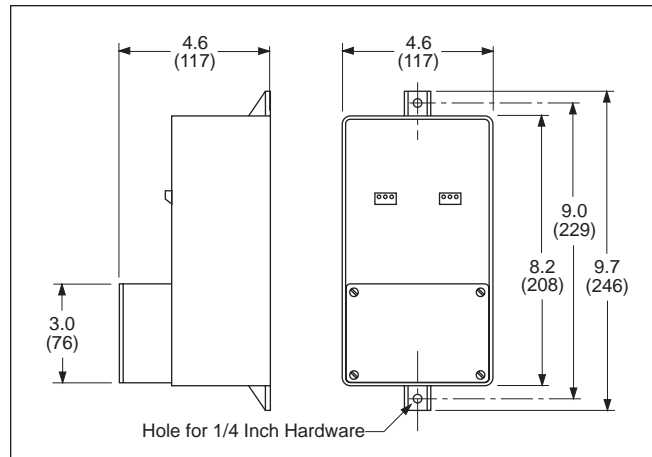

Figure 44-69. Dimensions in Inches (mm)

## Wiring Diagram

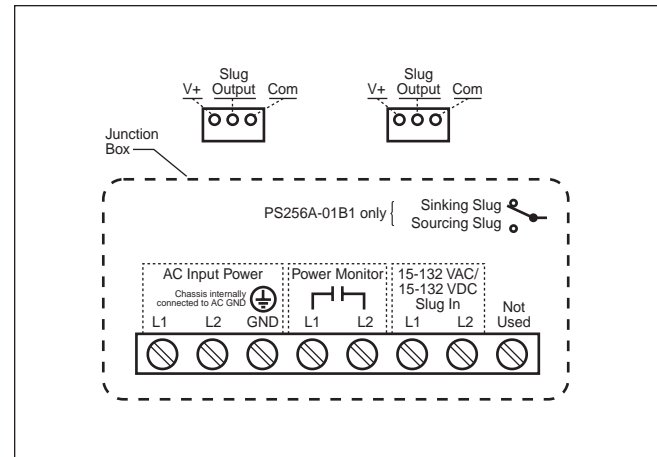

Figure 44-70. Wiring Diagram