

**HAZARDOUS LOCATION and  
INTRINSICALLY SAFE SOLENOID VALVES**

# NUMATICS® SPOOL AND SLEEVE FEATURES

## THE PATENTED SPOOL AND SLEEVE ASSEMBLY THE HEART OF EVERY NUMATICS AIR VALVE

The Numatics famous lapped spool and floating sleeve assembly is a matched set, machined from stainless steel to millionths of an inch precision. Its patented, balanced construction relies on an air bearing principle, eliminating always troublesome dynamic o-ring seals. The sleeve remains stationary in the valve housing, "floating" on six static seals. The sliding spool is "sealed" simply by virtue of the close finish tolerances.

With the spool floating on a film of air molecules, there is no metal-to-metal contact. Heat treating of the spools and sleeves gives a hardness necessary to combat pipe scale and other air line contaminants. The spool is "balanced" with respect to air pressure,

and offers extreme versatility of valve application. It supplies true multipurpose construction. The floating sleeve insures freedom from any mechanical distortion imposed on the valve body. Lubricated or properly filtered dry air will insure longer life; however, the spool and sleeve's unique design, and its inherent resistance to contaminants and sticking, will provide years and years of troublefree service, exceeding industrial standards of design and performance.

All these factors give the Numatics spool and sleeve a reliability and long service life which have been field proven in maintenance-free operation, typically outlasting the life of the machine on which it was installed. Its rugged versatility is unmatched. It has been envied and maligned, copied and imitated .....but never duplicated.



### FEATURE

### ADVANTAGE

No Dynamic  
Rubber Packings

Both spool and sleeve are stainless steel, precision machined to close tolerances. They are a matched set and spools are not interchangeable.

Balanced  
Spool Design

Air enters the sleeve, and the matched fit allows minute leakage across the spool. This centers the spool in the sleeve and acts as an air bearing. There is no metal-to-metal contact.

Sealing is accomplished by the closely maintained fit between the spool and sleeve.

Air bearing principle allows all valves to operate dry without any lubrication.

Vacuum to 300 PSIG independent of pilot pressure. Full back pressure at any port does not affect operation. There is no blow-by to exhaust during spool shift.

Consistent valving action independent of pressure or vacuum.

Constant shifting forces thus making direct solenoid operation possible.

Provides multipurpose valve versatility.

Longest Service Life

Razor sharp edges on the spool are a perfect shear against the holes in the sleeve to fight air line contaminants.

2 micro inch surface finish on O.D. (outside diameter) of spool and I.D. (inside diameter) of sleeve make it difficult for air line contaminants to adhere.

Floating Spool and  
Sleeve Construction

Static o-ring seals float the sleeve in the body, eliminating binding caused by temperature changes or uneven torquing of mounting bolts and pipe fittings.

**TABLE OF CONTENTS**

**HAZARDOUS LOCATION VALVES**

- L1 Series: 1/8 and 1/4 tapped, inline 4-way, Cv = 1.0 . . . . . 4 – 5
- L2 Series: 1/4 and 3/8 tapped, inline 4-way, Cv = 1.7 . . . . . 6 – 7
- Operator Features and Options for SXD4, DXD4, and DXP4 Series . . . . . 8
- Mark 7 Series: SXD4 and DXD4, Multi-purpose 4-way  
1/8 and 1/4 tapped, Cv = 0.4 . . . . . 9 – 10
- SPA 40 Series: DXP4, No Voltage Release and Electrically Tripped  
1/4, 3/8, and 1/2 tapped, Multi-purpose 4-way . . . . . 11 – 12

**INTRINSICALLY SAFE VALVES**

- L1 Series: 1/8 and 1/4 tapped inline 4-way, Cv = 1.0 . . . . . 13 – 14
- L2 Series: 1/4 and 3/8 tapped inline 4-way, Cv = 1.7 . . . . . 15 – 16
- SPA 3 Series: 10-32 and 1/8 tapped, Multi-purpose 4-way, Cv = .35 . . . . . 17 – 18
- 92088 and 92089 Series: Special L1 and L2 Series Hazardous Location  
and Intrinsically Safe . . . . . 19

**ACCESSORIES**

- Right Angle Flow Controls: 10-32 – 1/2 NPTF . . . . . 20
- Metering Valves and Inline Flow Controls . . . . . 21
- Filters, Regulators and Lubricators . . . . . 22
- Technical Data . . . . . 23



**HAZARDOUS LOCATION  
LINE MOUNTED  
1/8 NPTF AND 1/4 NPTF VALVES  
SERIES L1X**

Numatics has adapted a low wattage explosion proof operator for hazardous locations to its compact, high flow, L1 Series valve body assemblies. All Solenoid-Pilot actuated functions offered with the L1 Series are available with Series L1X.

Valves may be mounted in any position and will mount on L1 Series manifolds. When manifold mounted, it is necessary to use every other station with a blank station plate between valves.

All valves are approved for use in the following atmospheres:

- CLASS I: Groups C and D
- CLASS II: Groups E, F and G

Approvals: U.L. File E37780  
CSA File LR 20894-14

**OPERATING DATA**

**PRESSURE RANGE:**

Internal Pilot Supply: 14.5 PSIG - 100 PSIG

External Pilot Supply:

Main Valve: 28" Hg. vacuum to 145 PSIG

Pilot Supply: Same as internal pilot supply

**TEMPERATURE RANGE:** -40° F to +115° F ambient.

**SERVICE:** Valves can be used on the following properly filtered media:

Lubricated air, dry (oil free) air, vacuum, and non-corrosive, non-toxic, non-flammable dry gases. See Numatics' Engineering and Technical Data for a list of recommended lubricants and filtration requirements for unlubricated service.

**FLOW CAPACITY:** L1X valves have a Cv of 1.0. See Numatics' Engineering and Technical Data for complete flow chart.



L12XA452B

**ELECTRICAL SPECIFICATIONS**

**SOLENOIDS:** All solenoids are continuous duty rated. Standard A.C. voltage is 120/60. Standard D.C. voltage is 24 VDC. 12-240/60 A.C. and 6-120 volt D.C. available on special order.

	Inrush Current (amps)	Holding Current (amps)	D.C. Watts, Inrush and Holding All Voltages (max)	Time to Energize (seconds)	Time to De-energize (seconds)
120/60	.056	.029	2.5	.012	.040
24 VDC	.075	.075	1.8	.020	.030

**MODEL SELECTION CHART**

VALVE TYPE	MODEL NUMBER		A.N.S.I. SYMBOL	WIRING OPTION
	1/8 NPTF	1/4 NPTF		
Single Solenoid Pilot, 2-Position, Spring Return	L11XA452	L12XA452		Add one letter to the model number and specify volts and hertz. O = Standard A.C. Hardwired with 24" Solenoid Leads B = Standard D.C. Hardwired with 24" Solenoid Leads
Double Solenoid Pilot, 2-Position, Detented	L11XX452	L12XX452		
Double Solenoid Pilot, 3-Position, Dual Pressure In Neutral	L11XX552	L12XX552		<b>SPECIAL OPTION</b> Add to the model number. 014A = External Pilot Supply 011B = Flush Locking Override In The Pilot Adapter. 018D = Side Cylinder Ports In the Body. To Adapt To Actuator Adapters or Cylinders
Double Solenoid Pilot, 3-Position, All Ports Blocked In Neutral	L11XX652	L12XX652		

Top Dimensions = Inches  
Bottom Dimensions = Millimeters  
(in Parentheses) = Millimeters

### SOLENOID PILOT ACTUATED DIMENSIONS AND PARTS

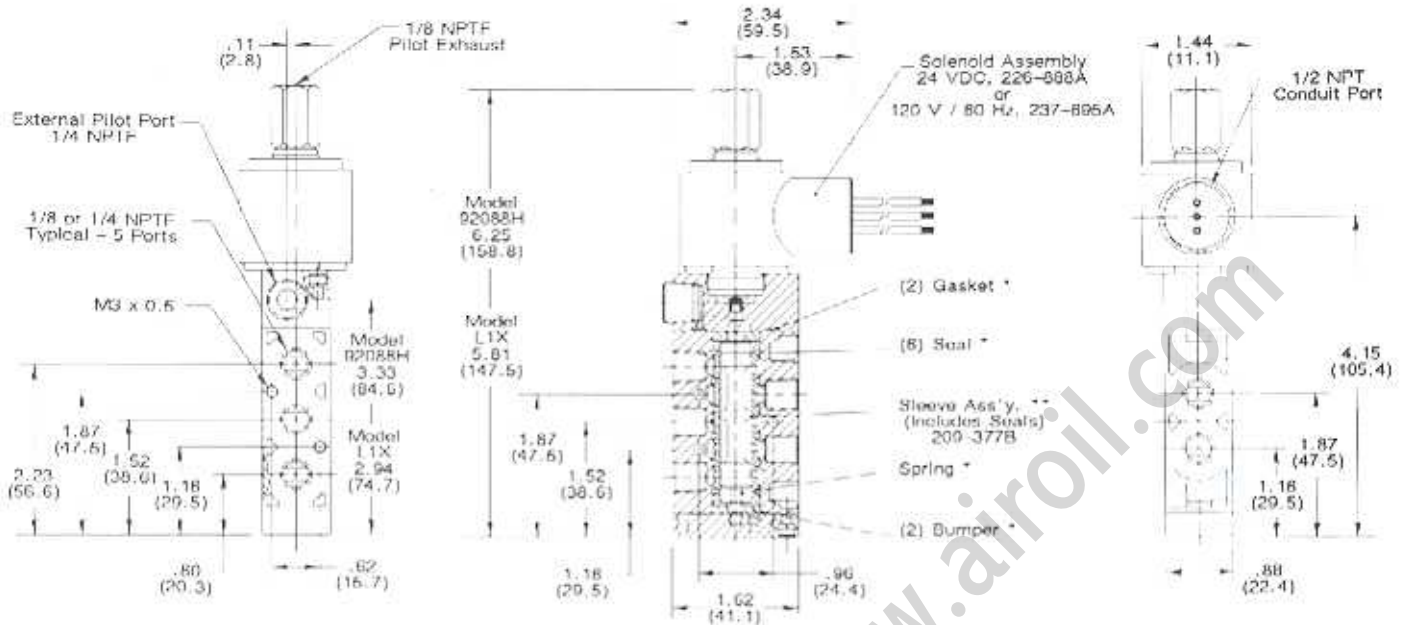

L12XX452B

L12XX552B, L12XX652B

"018D" OPTION

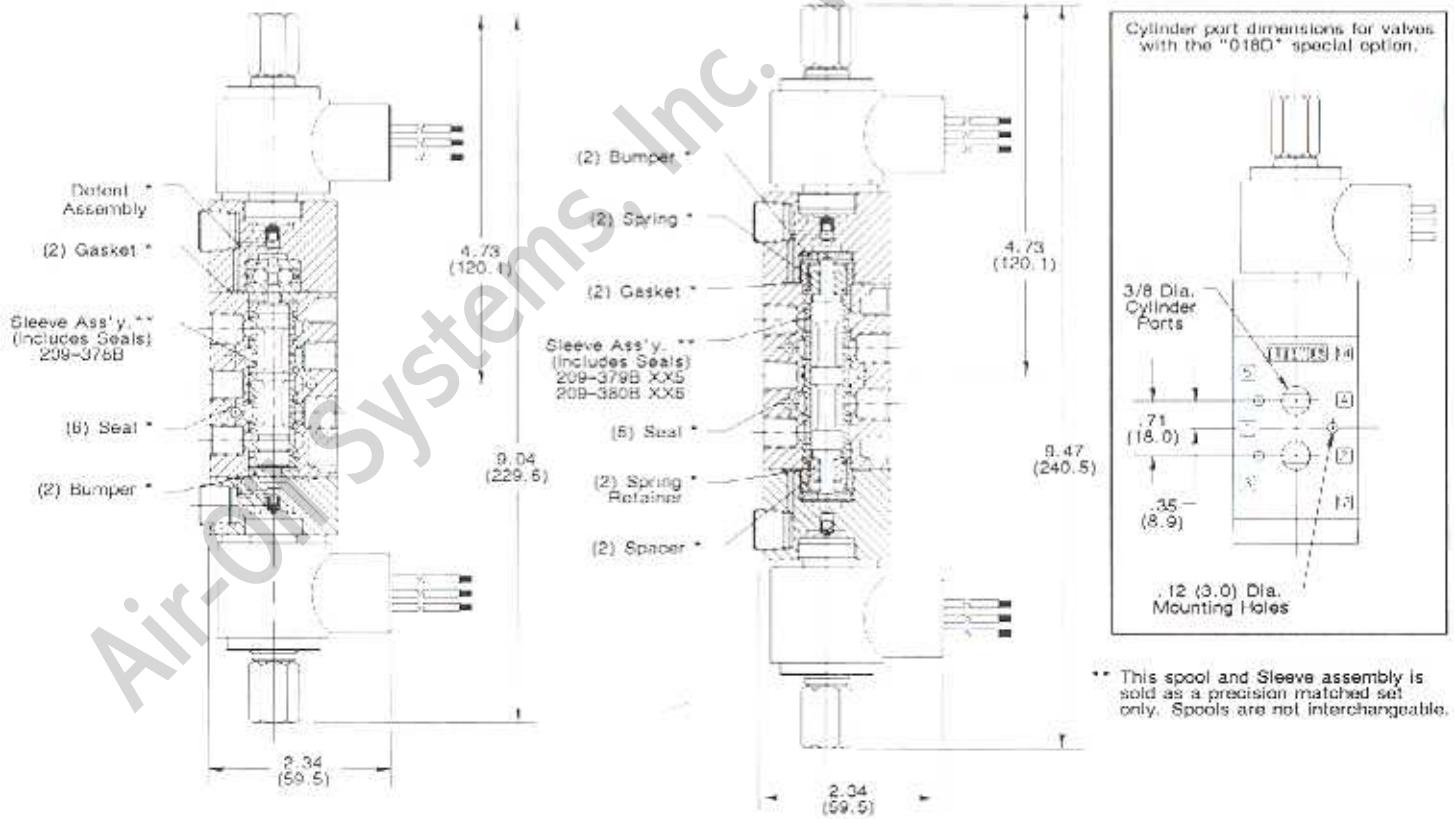

Cylinder port dimensions for valves with the "018D" special option.

\*\* This spool and Sleeve assembly is sold as a precision matched set only. Spools are not interchangeable.

#### EXTERNAL PILOT SUPPLY

To convert any valve to external pilot supply, remove the adapter from the valve body, rotate the gasket to block the internal supply, and replace the adapter in the same position. Remove the 1/4 NPTF pipe plug from the adapter and supply external pilot pressure to this port.

On double solenoid-pilot valves, both ends must be converted.

External pilot supply must be used if pressure is supplied to any port except No. 1

#### \* VALVE REPAIR KITS

Includes all internal parts except Sleeve Assembly or Solenoids

Valve Series	Kit Number
L11XA4, L12XA4	L1-K1
L11XX4, L12XX4	L1-K2
L11XX5, L12XX5 L11XX6, L12XX6	L1-K3



**HAZARDOUS LOCATION  
LINE MOUNTED  
1/4 NPTF AND 3/8 NPTF VALVES  
SERIES L2X**

Numatics has adapted a low wattage explosion proof operator for hazardous locations to its compact, high flow, L2 Series valve body assemblies. All Solenoid-Pilot actuated functions offered with the L2 Series are available with Series L2X.

Valves may be mounted in any position and will mount on L2 Series manifolds. When manifold mounted, it is necessary to use every other station with a blank station plate between valves.

All valves are approved for use in the following atmospheres:

- CLASS I: Groups C and D
- CLASS II: Groups E, F and G

Approvals: U.L. File E37780  
CSA File LR 26894-14

**OPERATING DATA**

**PRESSURE RANGE:**

- Internal Pilot Supply: 14.5 PSIG – 100 PSIG
- External Pilot Supply: -
- Main Valve: 28" Hg. vacuum to 145 PSIG
- Pilot Supply: Same as internal pilot supply

**TEMPERATURE RANGE:** -40° F to +115° F ambient.

**SERVICE:** Valves can be used on the following properly filtered media:

Lubricated air, dry (oil free) air, vacuum, and non-corrosive, non-toxic, non-flammable dry gases. See Numatics' Engineering and Technical Data for a list of recommended lubricants and filtration requirements for unlubricated service.

**FLOW CAPACITY:** L2X valves have a Cv of 1.7. See Numatics' Engineering and Technical Data for complete flow chart.

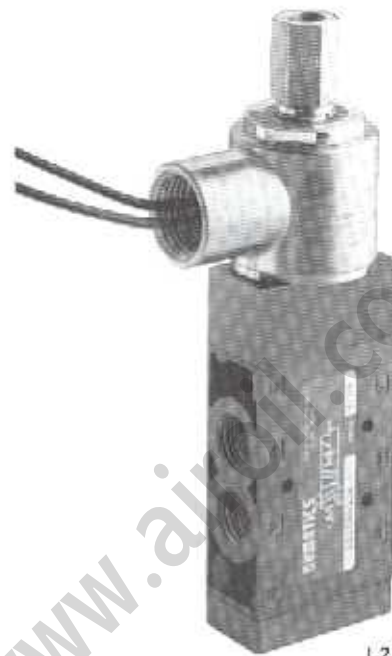

L22XA452B

**ELECTRICAL SPECIFICATIONS**

**SOLENOIDS:** All solenoids are continuous duty rated. Standard A.C. voltage is 120/60. Standard D.C. voltage is 24 VDC. 12-240/60 A.C. and 6-120 volt D.C. available on special order.

	Inrush Current (amps)	Holding Current (amps)	D.C. Watts, Inrush and Holding All Voltages (max)	Time to Energize (seconds)	Time to De-energize (seconds)
120/60	.056	.029	2.5	.012	.040
24 VDC	.075	.075	1.8	.020	.030

**MODEL SELECTION CHART**

VALVE TYPE	MODEL NUMBER		A.N.S.I. SYMBOL	WIRING OPTION
	1/4 NPTF	3/8 NPTF		
Single Solenoid Pilot, 2-Position, Spring Return	L22XA452	L23XA452		Add one letter to the model number and specify volts and hertz. O - Standard A.C. Hardwired with 24" Solenoid Leads B - Standard D.C. Hardwired with 24" Solenoid Leads
Double Solenoid Pilot, 2-Position, Detented	L22XX452	L23XX452		
Double Solenoid Pilot, 3-Position, Dual Pressure In Neutral	L22XX552	L23XX552		<b>SPECIAL OPTION</b> Add to the model number. 014A = External Pilot Supply 011B = Flush Locking Override In The Pilot Adapter 018D = Side Cylinder Ports In the Body. To Adapt To Actuator Adapters or Cylinders
Double Solenoid Pilot, 3-Position, All Ports Blocked In Neutral	L22XX652	L23XX652		

Top Dimensions = Inches  
 Roll-in Dimensions  
 (In Parentheses) = Millimeters

# SOLENOID PILOT ACTUATED DIMENSIONS AND PARTS

**NUMATICS®**  
**L2X SERIES**  
**HAZARDOUS LOCATION**

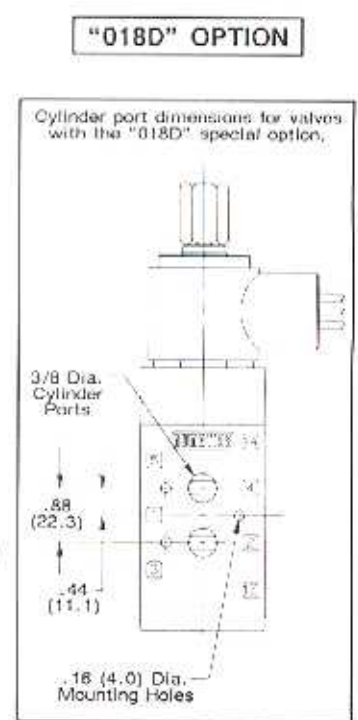
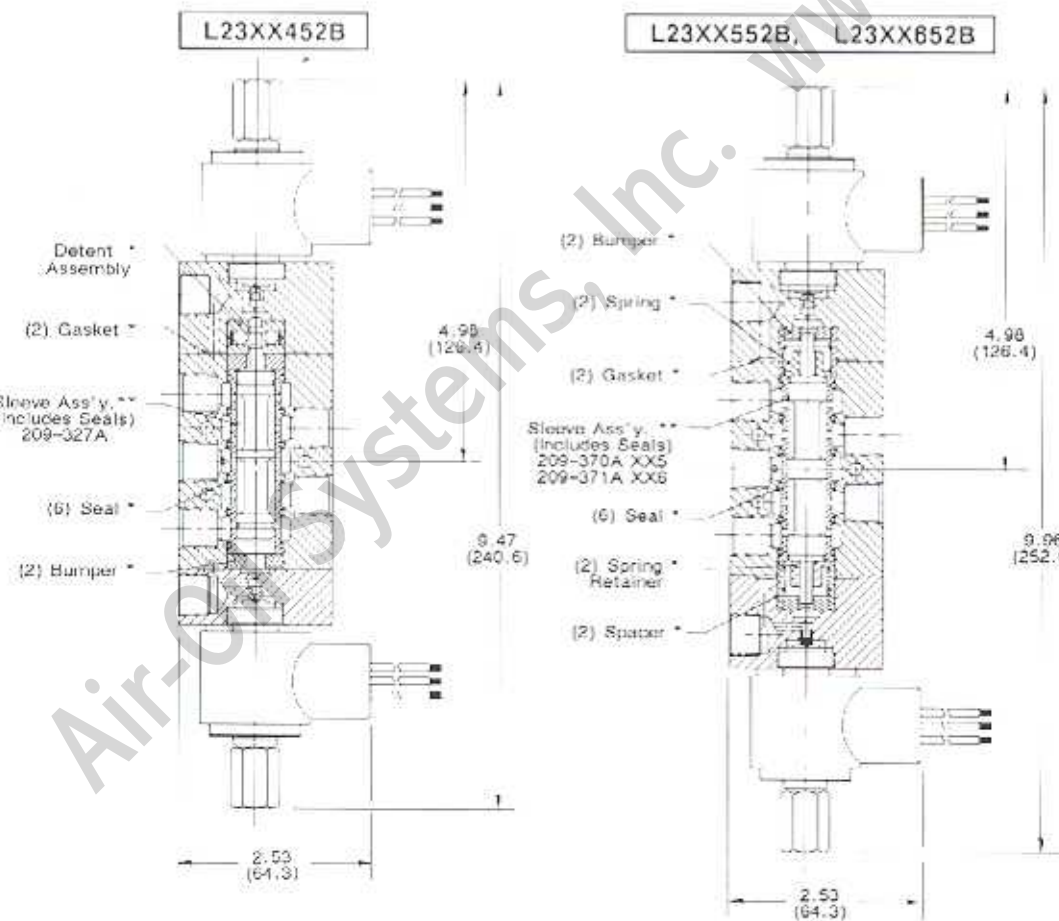
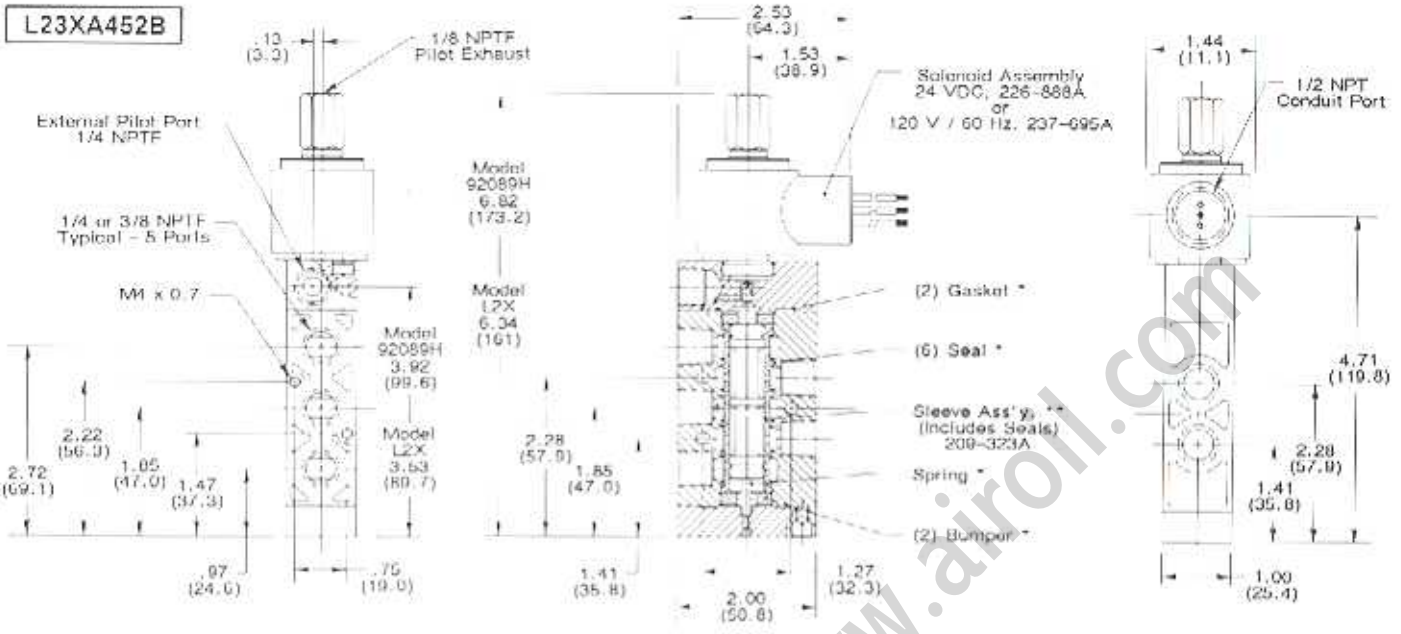

\*\* This spool and Sleeve assembly is sold as a precision matched set only. Spools are not interchangeable.

### EXTERNAL PILOT SUPPLY

To convert any valve to external pilot supply, remove the adapter from the valve body, rotate the gasket to block the internal supply, and replace the adapter in the same position. Remove the 1/4 NPTF plug from the adapter and supply external pilot pressure to this port. On double solenoid-pilot valves, both ends must be converted. External pilot supply must be used if pressure is supplied to any port except No. 1

* VALVE REPAIR KITS	
Includes all internal parts except Sleeve Assembly or Solenoids	
Valve Series	Kit Number
L22XA4, L23XA4	L2-K1
L22XX4, L23XX4	L2-K2
L22XX5, L23XX5 L22XX6, L23XX6	L2-K3



**SPECIFICATIONS**

Numatics has developed a solenoid operator suitable for use in certain hazardous locations. This operator is designed to contain any spark that may originate within the solenoid, prohibiting it from reaching the environment. It is also designed to contain any explosions within the housing. It is approved by both Underwriters Laboratories and the Canadian Standards Association. The U.L. listing is under Solenoids For Use in Hazardous Locations, Guide VAPT File E61583. The C.S.A. file number is 42844. Solenoid valves using this operator are approved for use in the following atmospheres.

Class I, Division 1, Groups C and D (Nema types 7C and 7D). Class I locations may have flammable gases or vapors in the atmosphere in sufficient quantity to produce an explosion at any time.

Class II, Division 1, Groups E, F, and G (Nema types 9E, 9F and 9G). Class II locations may have the presence of combustible dust in the atmosphere at any time.

These operators have also been approved as Watertight (CSA Encl. 4) (Nema 4)

The solenoid housing is rotatable 360 degrees for ease of wiring. To orient the 1/2 NPTF conduit hub, loosen the cover with a wrench on the top .62" wrench flats. Rotate the housing to the desired position and tighten the cover. The cover must be tight to comply with U.L. and CSA approvals.

**Important:** Do not orient the conduit hub by rotating the complete solenoid. The solenoid must be tight in the valve body or adapter to insure proper valve stroke. Tighten with wrench No. 137-157A.

**SOLENOID DATA**

VOLTAGE	WATTS	CURRENT (AMPS)	
		Inrush	Holding
115-120/60	11	.42	.165
100-115/50			
220-240/60	11	.21	.083
200-230/50			
24/50/60	7	1.9	.61
24 VDC		6	.26

Solenoids have a Class "A" (105°C) insulation and are continuous duty rated. 18" pigtail leads are standard. 12VDC and 125 VDC available on special order. Consult factory.

**COMMON VALVE SPECIFICATIONS**

Ambient Temperature Range: Minimum -40° F (-40° C)  
Maximum UL Listed for 115° F (46.1° C)

Temperature Code T3C - valve should not be installed in areas where vapors and gases having an ignition temperature less than 320° F (160° C) are present.

**SERVICE:** Valves can be used on the following properly filtered media:

Lubricated air, dry (oil free) air, vacuum, and non-corrosive, non-toxic, non-flammable dry gases. See Numatics' Engineering and Technical Data for a list of recommended lubricants and filtration requirements for unlubricated service.

Wrench Number 137-157A

Required for solenoid installation on valve.  
(for .75" wrench flats)

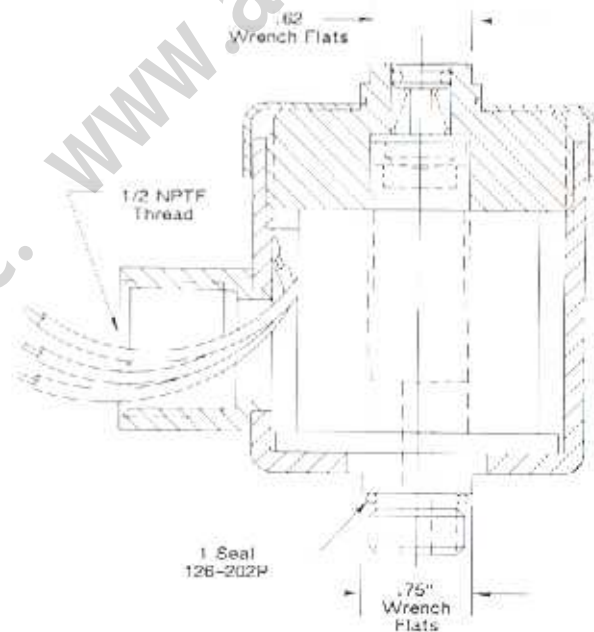

PART NUMBERS			
Voltage	Solenoid Capsule Assembly		
	Flush Override	No Override	Solenoid Coil Only
115-120/60 100-115/50	237-221B	237-218B	139-432A
200-240/60 200-230/50	237-222B	237-219B	139-433A
24/50/60	237-223B	237-220B	139-434A
24 VDC	226-401B	226-400B	139-435A

**CAUTION:** A.C. and D.C. solenoids appear identical but are constructed of different materials.  
**DO NOT INTERCHANGE PARTS OR COILS**





1/8 AND 1/4 NPTF,  
MULTI-PURPOSE, 4-WAY  
DIRECT SOLENOID ACTUATED

**numatics®**  
MARK 7 SERIES  
HAZARDOUS LOCATION

MK7 hazardous location valves are heavy duty, multi-purpose, 2-position valves used primarily for the control of a small bore, short stroke air cylinders where part stroke stopping, or inching of the cylinder is not required. They may be used as normally open or closed 2 or 3-Way valves, single or dual pressure 4-Ways, or as selector or diverter valves. Full back pressure at any port has no operating effect on the valve and they may be mounted in any position.

Two configurations are available: Single solenoid, spring return valves are actuated by a "maintained" electrical signal. The spring returns the spool when the solenoid is de-energized. Double solenoid detented valves are actuated by either a "momentary" or a "maintained" electrical signal alternately on each solenoid. The detent holds the spool in position after electrical power is removed and prevents inadvertent spool shift due to vibration or shock.

Both 1/8 NPTF and 1/4 NPTF sub-bases are available. The 1/8 NPTF base is available with a common exhaust port that internally connects ports EA and EB. Manifold mounting is not available.

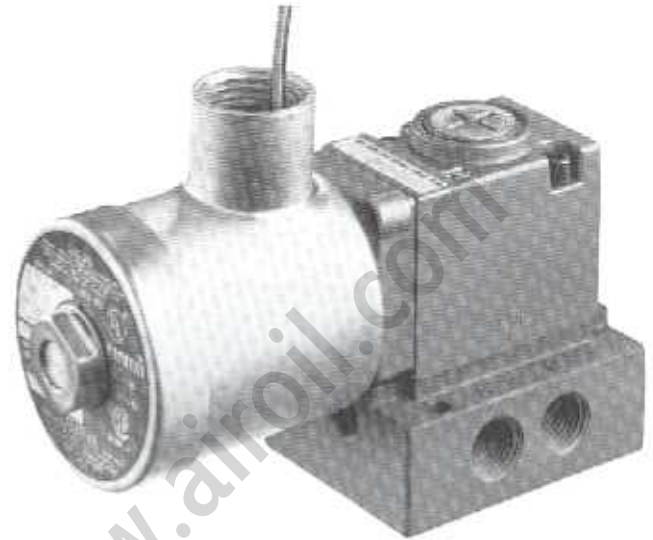

PRESSURE RANGE: 28" Hg. vacuum to 150 PSIG

FLOW CAPACITY: CV = .4 (18.4 SCFM max. to atmosphere at 80 PSIG)

TIME TO ENERGIZE:	A.C.	D.C.
Single Solenoid	.012 Sec.	.028 Sec.
Double Solenoid	.010 Sec.	.028 Sec.

TIME TO DE-ENERGIZE:	A.C.	D.C.
Single Solenoid	.018 Sec.	.012 Sec.

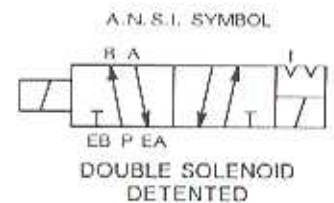
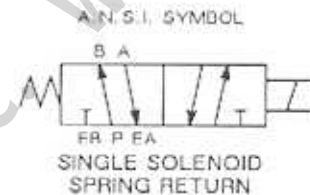

**MODEL SELECTION CHART** - Construct the desired model number from seven "groups" below, and add a specific voltage to the end of the number (e.g. 12SXD441O 120/60, 12SXD44O011M 120/60).

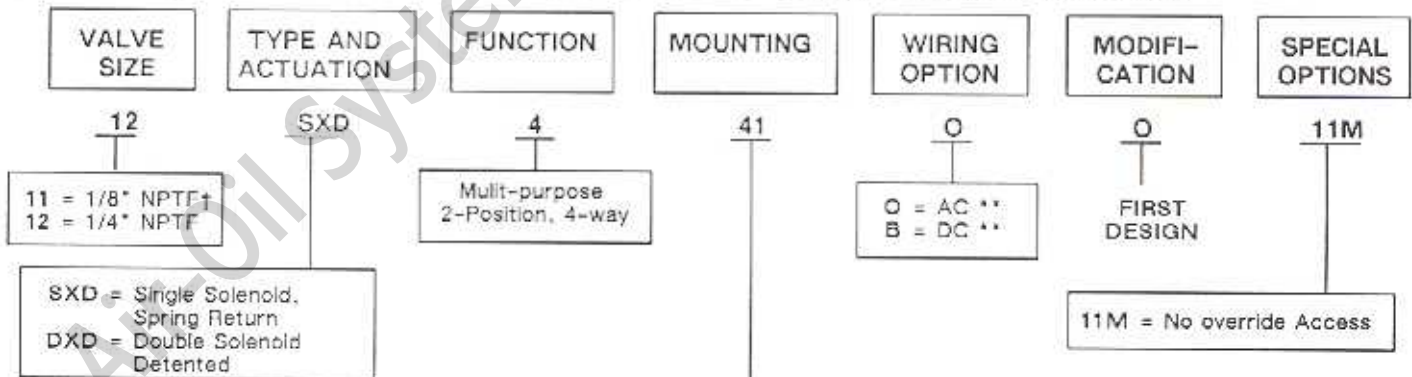

- 00 = Valve Unit Only No Base
- 01 = Valve unit with speed control, no base
- 02 = Valve unit with extra long screws for use with speed control
- 41 = Standard base, side ports only, individual exhaust
- 43 = Standard base, side and bottom ports, individual exhaust
- 44 = Standard base, side ports, common exhaust \*
- 46 = Standard base, side ports only, individual exhaust with speed control
- 48 = Standard base, side and bottom ports, individual exhaust with speed control
- 49 = Standard base, side ports, common exhaust with speed control \*
- 54 = Standard base, side and bottom ports, common exhaust \*
- 55 = Standard base, side and bottom ports, common exhaust with speed control \*

\* Available only with 1/8 NPTF ports  
 \*\* Specify Volts and Hz.  
 † 1/8 NPTF is the basic size. Use "11" for all valve units, (00,01,02 mountings)

# numatics®

## MARK 7 SERIES HAZARDOUS LOCATION

### DIRECT SOLENOID ACTUATED DIMENSIONS AND PARTS

Top Dimensions = Inches  
Bottom Dimensions  
(In Parentheses) = Millimeters

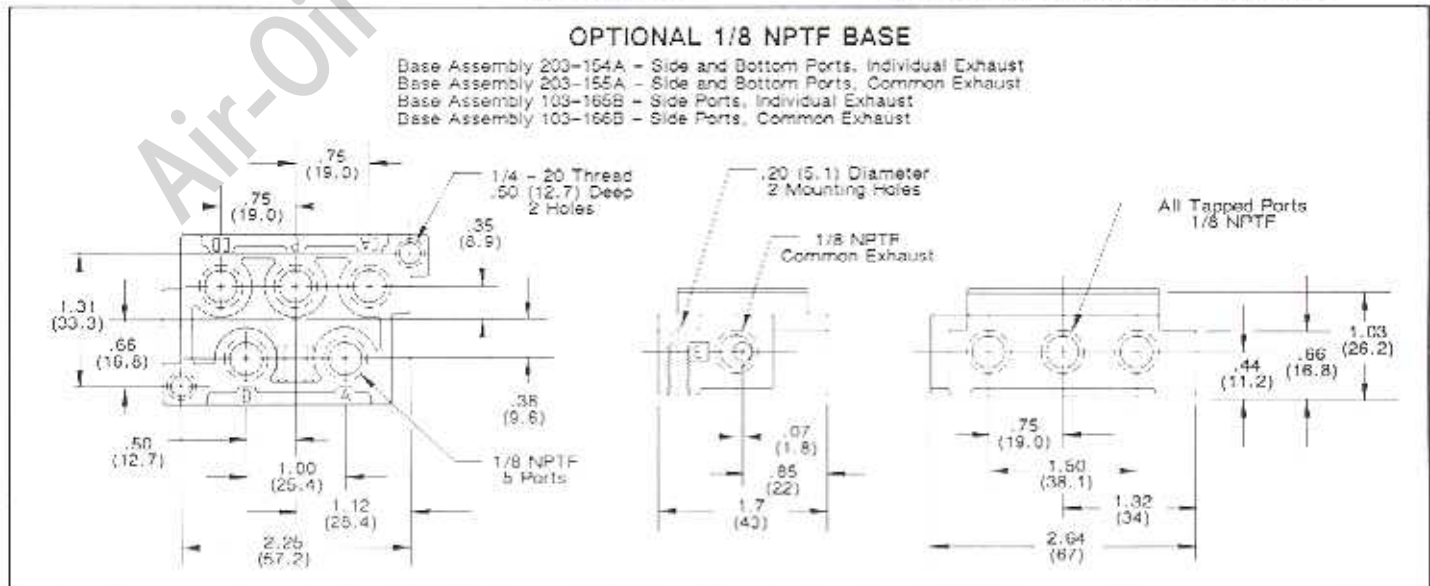
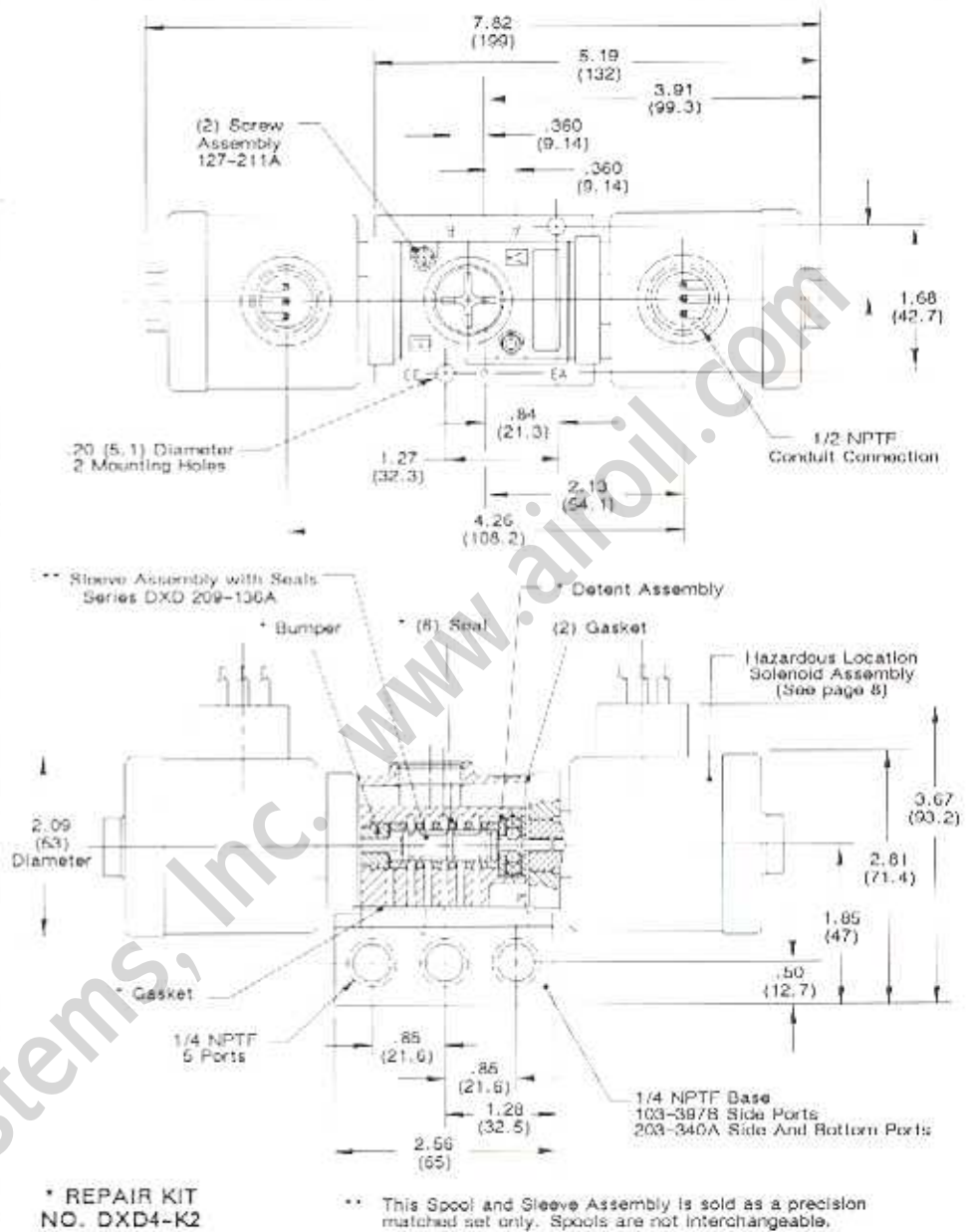
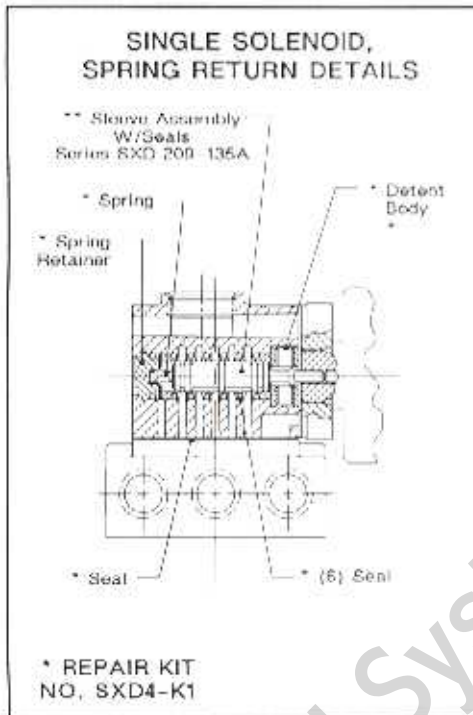
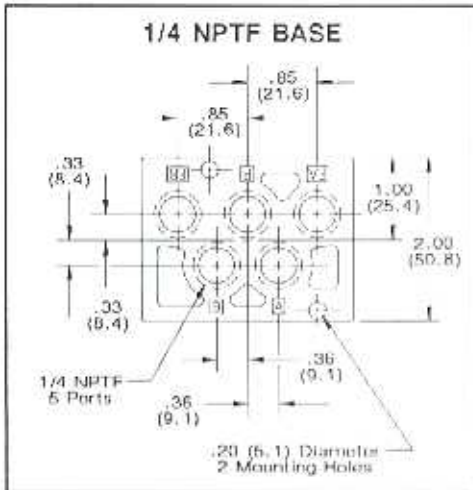



1/4 NPTF, 3/8 NPTF, AND 1/2 NPTF,  
MULTI-PURPOSE, 4-WAY  
SOLENOID-PILOT ACTUATED

**numatics®**  
SPA 40 SERIES  
HAZARDOUS LOCATION

**“NO VOLTAGE RELEASE”  
OR  
“ELECTRICALLY TRIPPED”**



These valves offer a special modification to the standard SPA-40 Series solenoid-pilot actuated valves to provide for both “no voltage release” and “electrically tripped” functions in one valve. Either can be obtained simply by changing one external pilot connection.

The main valve is a 5-ported multi-purpose, 4-way which allows any port to be pressurized. They may be used as normally open or closed 2 or 3-way valves, single or dual pressure 4-ways, or as selector or diverter valves. However, they are usually installed as 3-ways to provide shutdown in the event that electrical power is either lost or provided – depending on the requirement.

**I. NO VOLTAGE RELEASE**

This arrangement has the pilot piped as normally closed with pressure to port “E”. Port “X” is exhaust. With the solenoid held energized, the pilot is exhausted. This allows the main valve to be manually shifted. If electrical power is lost, pilot pressure shifts the main spool back. It cannot be manually reset until electrical power is restored to the solenoid.

**II. ELECTRICALLY TRIPPED**

This arrangement has the pilot piped as normally closed with pressure to port “X”. Port “E” is exhausted. With the solenoid de-energized, the main valve can be manually shifted. If the solenoid is energized, pilot pressure shifts the main spool. The valve cannot be reset until electrical power is removed.

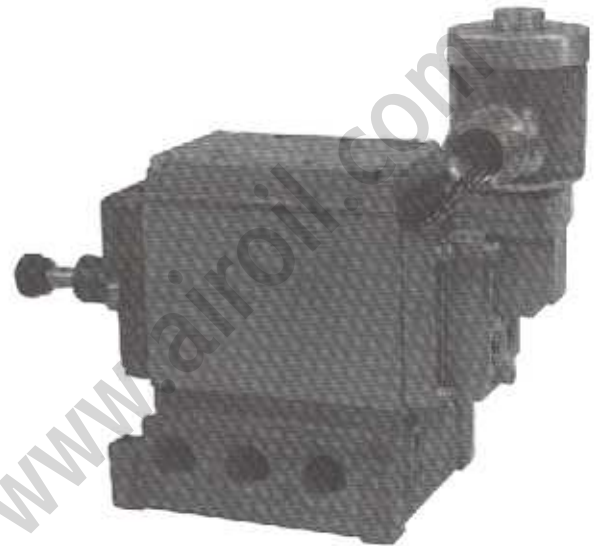

**PRESSURE RANGE:**

Main Valve: 28" Hg. vacuum to 150 PSIG  
Pilot Supply: 15 - 125 PSIG

**FLOW CAPACITY:**

1/4 NPTF: Cv = 2.8  
3/8 NPTF: Cv = 3.0  
1/2 NPTF: Cv = 3.5

**SOLENOID VOLTAGES AND APPROVALS:** See page 8.

NO VOLTAGE RELEASE

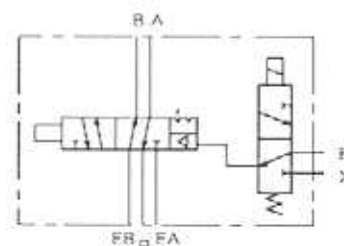

ELECTRICALLY TRIPPED

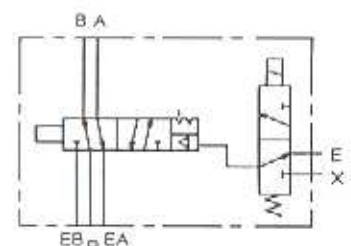

**MODEL SELECTION CHART**

(\* Number Must Be Complete Through 13 Digits)

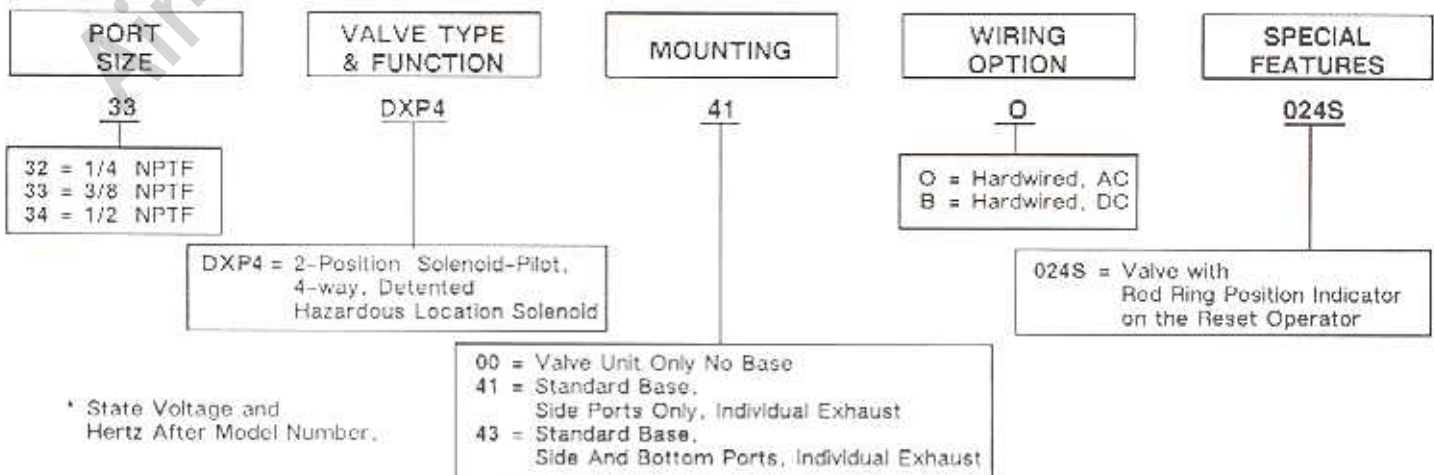

\* State Voltage and Hertz After Model Number.

# numatics®

## SPA 40 SERIES HAZARDOUS LOCATION

### DIMENSIONS AND PARTS

Top Dimensions = Inches  
Bottom Dimensions  
(In Parentheses) = Millimeters

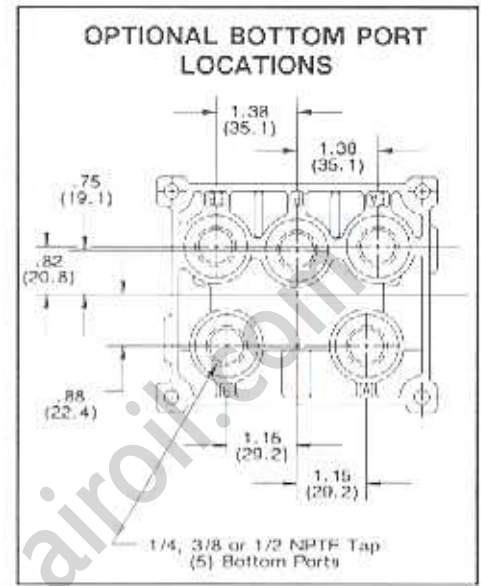
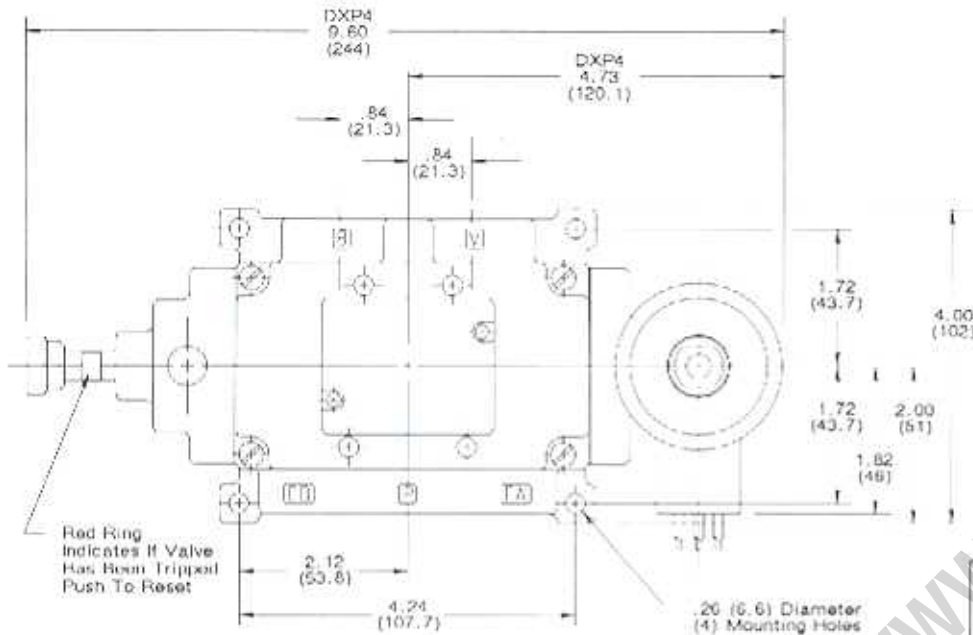

#### BASE PART NUMBERS

##### Side Ports, Individual Exhaust

1/4 NPTF	3/8 NPTF	1/2 NPTF
103-401C	103-402C	103-403C

##### Side and Bottom Ports, Individual Exhaust

1/4 NPTF	3/8 NPTF	1/2 NPTF
203-328B	203-329B	203-330B

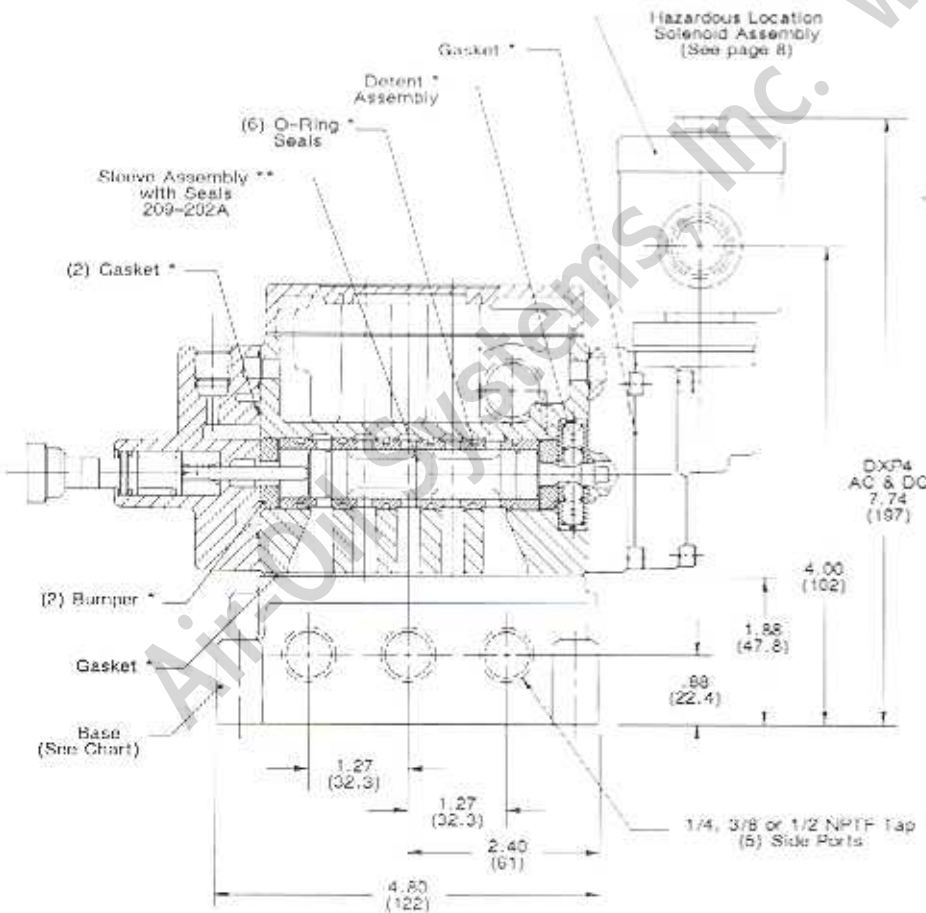

\*\* This spool and Sleeve assembly is sold as a precision matched set only. Spools are not interchangeable.

#### \* VALVE REPAIR KIT No. DXP-K4

Includes all parts marked with an asterisk except Sleeve Assembly. Also includes internal pilot parts.

#### PILOT PORTING

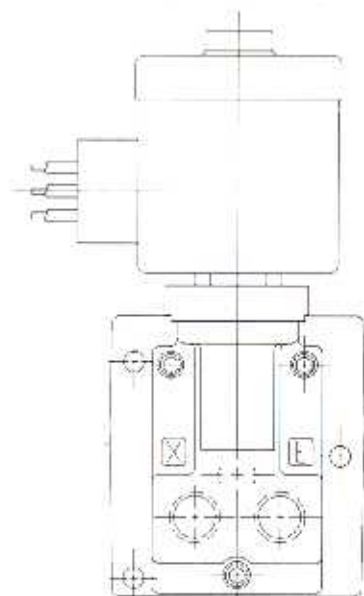

No Voltage Release  
Port E - Pressure  
Port X - Exhaust

Electrically Tripped  
Port X - Pressure  
Port E - Exhaust



1/8 NPTF AND 1/4 NPTF,  
MULTI-PURPOSE, 4-WAY  
SOLENOID-PILOT ACTUATED

**NUMATICS®**  
L1I SERIES  
INTRINSICALLY SAFE

INTRINSICALLY SAFE  
LINE MOUNTED  
1/8 NPTF AND 1/4 NPTF VALVES

L1I intrinsically safe valves are solenoid-pilot actuated, multipurpose, 4-way power valves. These valves are designed for use in explosive environments within an intrinsically safe system. The special solenoid is capable of operating at very low power levels, so that any spark that may be produced is not powerful enough to ignite any dust or gas present in the operating environment.

Intrinsically safe L1I valves are designed to operate only when connected to a current and voltage limiting safety barrier. The valve and wiring is not capable of releasing sufficient electrical or thermal energy under normal or abnormal conditions to cause ignition of a specific hazardous atmospheric condition in its most easily ignited concentration.

Suggested applications for Numatics L1I intrinsically safe valves include grain handling equipment, petrochemical processing plants, chemical and drug manufacturing, paint plants, flammable gas processing, mines and any other area where there is a likelihood of explosions or fire caused by arcing electrical devices.

Two valve configurations are available.

Single solenoid-pilot, spring return valves are actuated by a "maintained" electrical signal. The spring returns the spool to the original position when the electrical signal is removed.

Double solenoid-pilot, detented valves are actuated by either a "momentary" or a "maintained" electrical signal alternately on each solenoid. The detent holds the spool in position after electrical power is removed and prevents inadvertent spool shift due to vibration or shock.

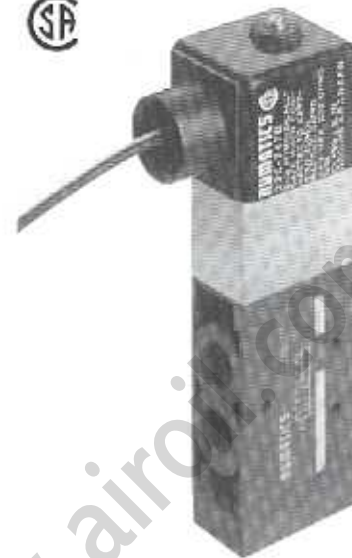

L121A452B

OPERATING DATA

SOLENOID APPROVALS:

CSA - File LR 42844-11  
FM - File J.I.2T7A3.AX

ELECTRICAL SPECIFICATIONS: See page 23.

RESPONSE TIME:

Energize: .022 Seconds at 100 PSIG  
De-energize .100 Seconds at 100 PSIG

PRESSURE RANGE:

Internal Pilot Supply: 14.5 PSIG - 120 PSIG  
External Pilot Supply:  
Main Valve: 28" Hg. vacuum to 145 PSIG  
Pilot Supply: Same as internal pilot supply

TEMPERATURE RANGE: -40° F to +115° F ambient.

SERVICE: Valves can be used on the following properly filtered media:

Lubricated air, dry (oil free) air, vacuum, and non-corrosive, non-toxic, non-flammable dry gases. See page 130-132 of the general catalog for a list of recommended lubricants and filtration requirements for unlubricated service.

FLOW CAPACITY: L1I valves have a Cv of 1.0. See Numatics' Engineering and Technical Data for complete flow chart.

MODEL SELECTION CHART

VALVE TYPE	MODEL NUMBER		A.N.S.I. SYMBOL	SPECIAL OPTIONS
	1/8 NPTF	1/4 NPTF		
Single Solenoid Pilot, 2-Position, Spring Return	L111A452B	L121A452B		Add letter to the model number. 014A = External Pilot Supply
Double Solenoid Pilot, 2-Position, Detented	L111I452B	L121I452B		018D = Side Cylinder Ports in the Body to Adapt to Actuator Adaptor or Cylinders.

# numatics®

L1T SERIES  
INTRINSICALLY SAFE

## SOLENOID PILOT ACTUATED DIMENSION AND PARTS

Top Dimensions = Inches  
Bottom Dimensions  
(In Parentheses) = Millimeters

### L121A452B

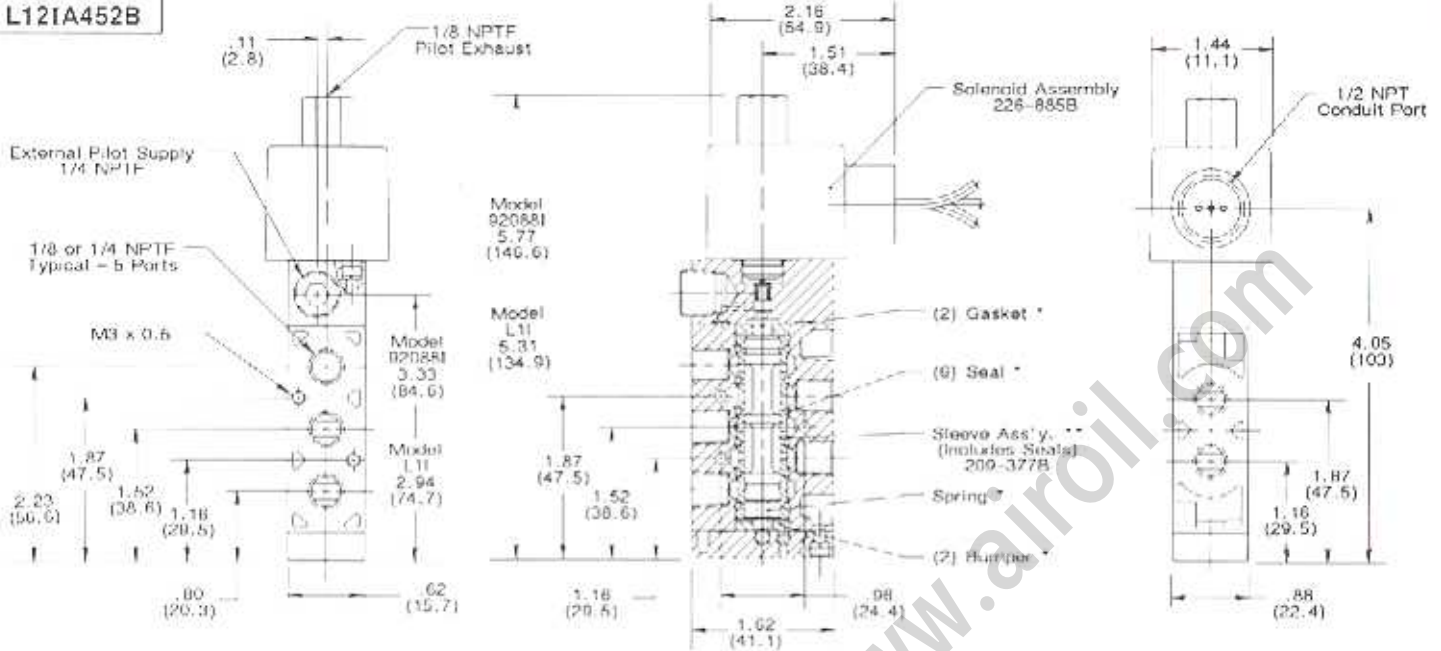

### L121I452B

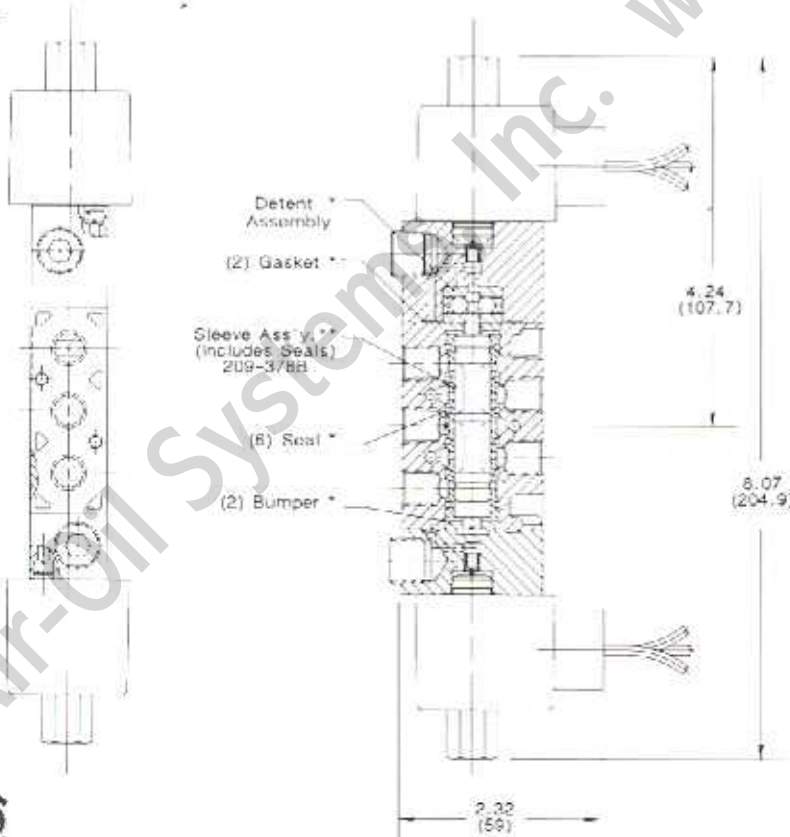

### "018D" OPTION

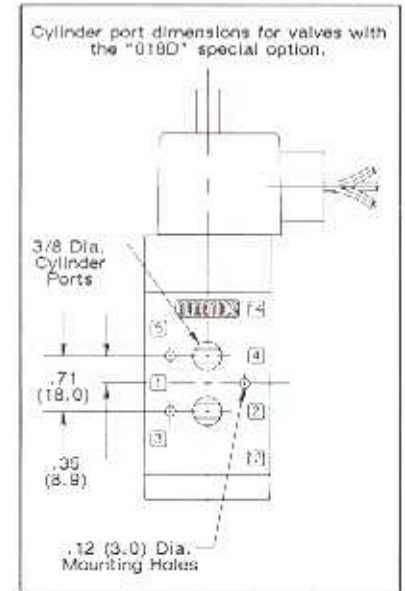

\*\* This spool and Sleeve assembly is sold  
as a precision matched set only.  
Spools are not interchangeable.



### EXTERNAL PILOT SUPPLY

To convert any valve to external pilot supply, remove the adapter from the valve body, rotate the gasket to block the internal supply, and replace the adapter in the same position. Remove the 1/4 NPTF pipe plug from the adapter and supply external pilot pressure to this port.

On double solenoid-pilot valves, both ends must be converted.

External pilot supply must be used if pressure is supplied to any port except No. 1

### \* VALVE REPAIR KITS

Includes all internal parts except Sleeve  
Assembly or Solenoids

Valve Series	Kit Number
L11A4, L121A4	L1-K1
L11I4, L121I4	L1-K2



1/4 NPTF AND 3/8 NPTF,  
MULTI-PURPOSE, 4-WAY  
SOLENOID-PILOT ACTUATED

**NUMATICS®**  
L2I SERIES  
INTRINSICALLY SAFE

**INTRINSICALLY SAFE  
LINE MOUNTED  
1/4 NPTF AND 3/8 NPTF VALVES**



L2I intrinsically safe valves are solenoid-pilot actuated, multipurpose, 4-way power valves. These valves are designed for use in explosive environments within an intrinsically safe system. The special solenoid is capable of operating at very low power levels, so that any spark that may be produced is not powerful enough to ignite any dust or gas present in the operating environment.

Intrinsically safe L2I valves are designed to operate only when connected to a current and voltage limiting safety barrier. The valve and wiring is not capable of releasing sufficient electrical or thermal energy under normal or abnormal conditions to cause ignition of a specific hazardous atmospheric condition in its most easily ignited concentration.

Suggested applications for Numatics L2I intrinsically safe valves include grain handling equipment, petrochemical processing plants, chemical and drug manufacturing, paint plants, flammable gas processing, mines and any other area where there is a likelihood of explosions or fire caused by arcing electrical devices.

Two valve configurations are available.

Single solenoid-pilot, spring return valves are actuated by a "maintained" electrical signal. The spring returns the spool to the original position when the electrical signal is removed.

Double solenoid-pilot, detented valves are actuated by either a "momentary", or a "maintained" electrical signal alternately on each solenoid. The detent holds the spool in position after electrical power is removed and prevents inadvertent spool shift due to vibration or shock.

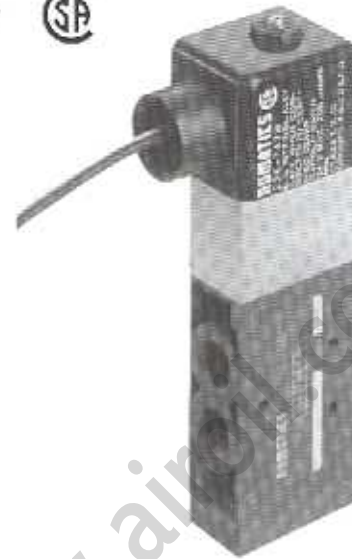

L221A452B

**OPERATING DATA**

**SOLENOID APPROVALS:**

CSA - File LR 42844-11

FM - File J.1.2T7A3.AX

**ELECTRICAL SPECIFICATIONS:** See page 23.

**RESPONSE TIME:**

Energize: .022 Seconds at 100 PSIG

De-energize: .100 Seconds at 100 PSIG

**PRESSURE RANGE:**

Internal Pilot Supply: 14.5 PSIG - 120 PSIG

External Pilot Supply:

Main Valve: 28" Hg. vacuum to 145 PSIG

Pilot Supply: Same as internal pilot supply

**TEMPERATURE RANGE:** -40° F to +115° F ambient.

**SERVICE:** Valves can be used on the following properly filtered media:

Lubricated air, dry (oil free) air, vacuum, and non-corrosive, non-toxic, non-flammable dry gases. See page 130-132 of the general catalog for a list of recommended lubricants and filtration requirements for unlubricated service.

**FLOW CAPACITY:** L2I valves have a Cv of 1.7. See Numatics' Engineering and Technical Data for complete flow chart.

**MODEL SELECTION CHART**

VALVE TYPE	MODEL NUMBER		A.N.S.I. SYMBOL	SPECIAL OPTION
	1/4 NPTF	3/8 NPTF		
Single Solenoid Pilot, 2-Position, Spring Return	L221A452B	L231A452B		Add letter to the model number.  014A = External Pilot Supply
Double Solenoid Pilot, 2-Position, Detented	L221I452B	L231I452B		018D = Side Cylinder Ports in the Body to Adapt to Actuator Adaptor or Cylinders.

**L23IA452B**

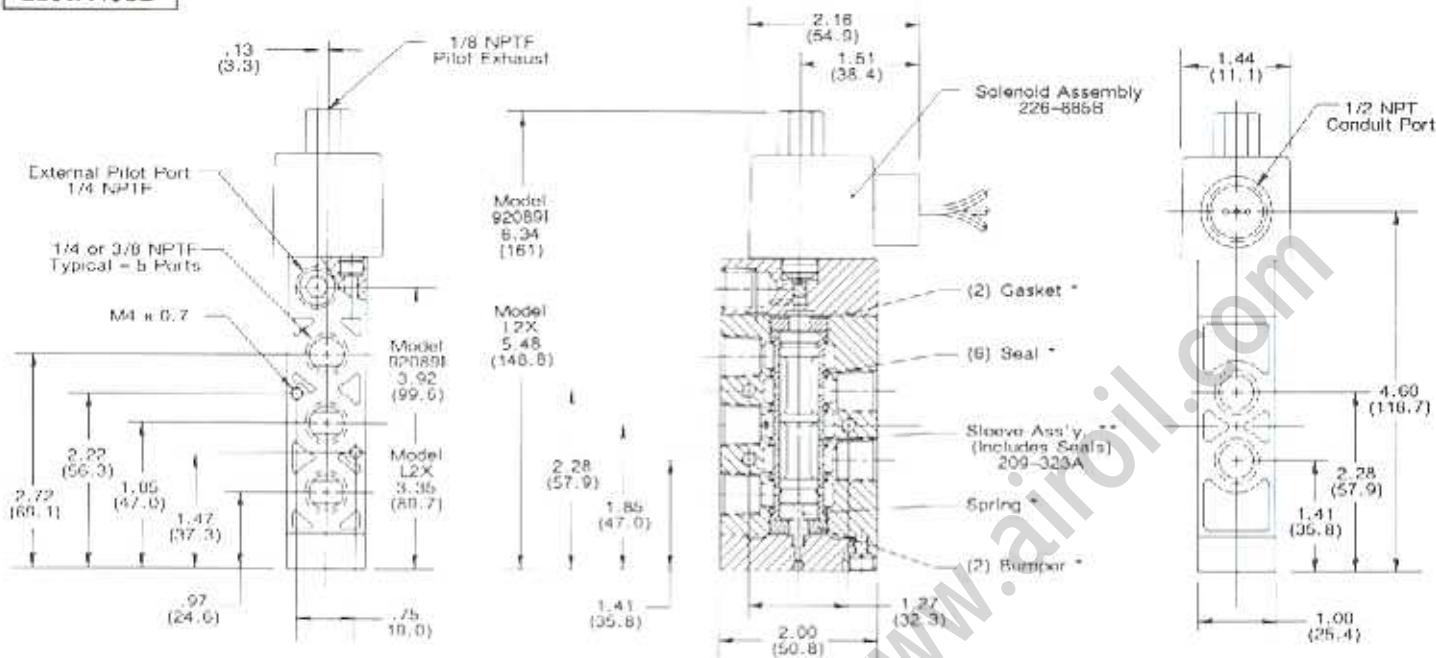

**L23II452B**

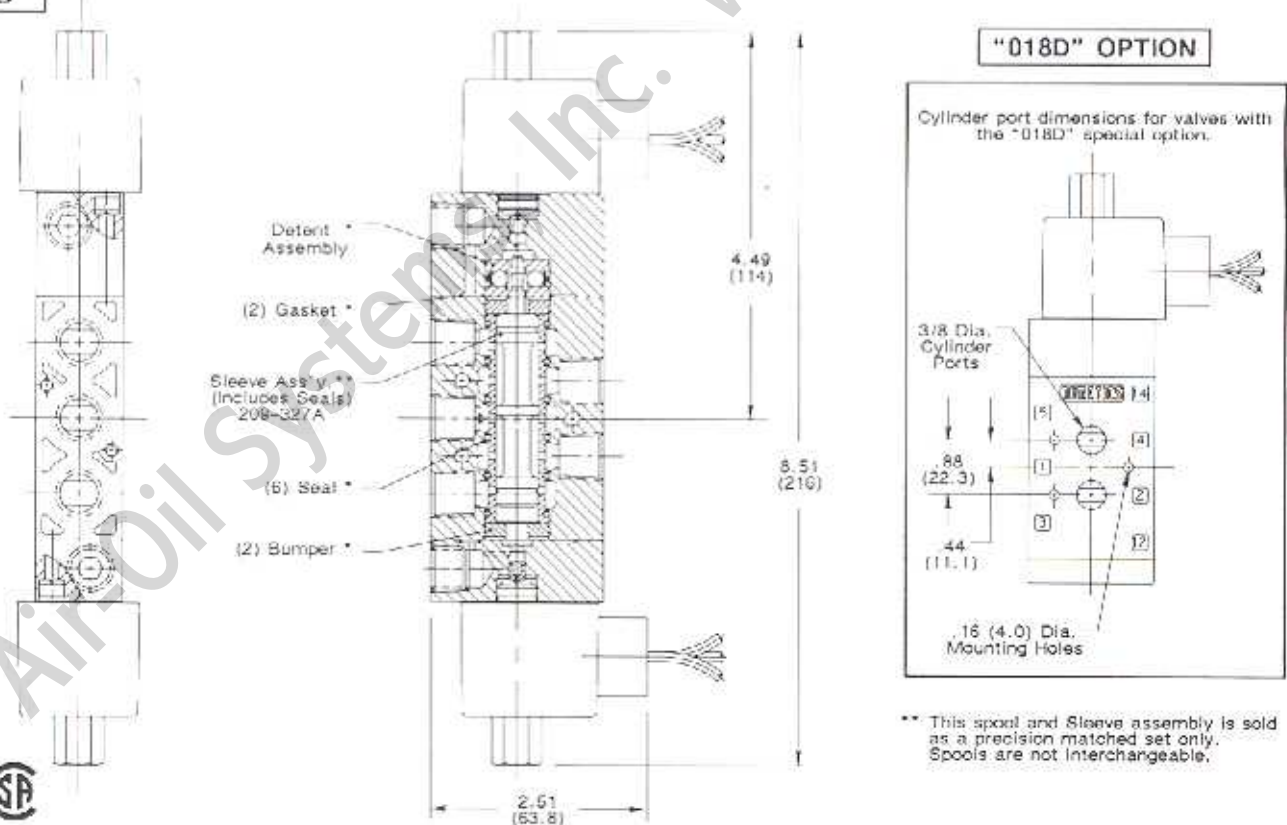

**EXTERNAL PILOT SUPPLY**

To convert any valve to external pilot supply, remove the adapter from the valve body, rotate the gasket to block the internal supply, and replace the adapter in the same position. Remove the 1/4 NPTF pipe plug from the adaptor and supply external pilot pressure to this port.  
On double solenoid-pilot valves, both ends must be converted.  
External pilot supply must be used if pressure is supplied to any port except No. 1

**\* VALVE REPAIR KITS**

Includes all internal parts except Sleeve Assembly or Solenoids

Valve Series	Kit Number
L22IA4, L23IA4	L2-K1
L22II4, L23II4	L2-K2



# 10-32 AND 1/8 NPTF, MULTI-PURPOSE, 4-WAY SOLENOID-PILOT ACTUATED

**NUMATICS®**  
SPA 3 SERIES  
INTRINSICALLY SAFE

SPA-3 intrinsically safe valves are solenoid-pilot actuated, multipurpose, 4-way power valves. These valves are designed for use in explosive environments within an intrinsically safe system. The special solenoid is capable of operating at very low power levels, so that any spark that may be produced is not powerful enough to ignite any dust or gas present in the operating environment.

Intrinsically safe SPA-3 valves are designed to operate only when connected to a current and voltage limiting safety barrier. The valve and wiring is not capable of releasing sufficient electrical or thermal energy under normal or abnormal conditions to cause ignition of a specific hazardous atmospheric condition in its most easily ignited concentration.

Suggested applications for Numatics SPA-3 intrinsically safe valves include grain handling equipment, petrochemical processing plants, chemical and drug manufacturing, paint plants, flammable gas processing, mines and any other area where there is a likelihood of explosions or fire caused by arcing electrical devices.

Two valve configurations are available.

Single solenoid-pilot, spring return valves are actuated by a "maintained" electrical signal. The spring returns the spool to the original position when the electrical signal is removed.

Double solenoid-pilot, detented valves are actuated by either a "momentary", or a "maintained" electrical signal alternately on each solenoid. The detent holds the spool in position after electrical power is removed and prevents inadvertent spool shift due to vibration or shock.

SPA-3 valves are shipped, as standard, with internal pilot supply from port P. If it is necessary to supply pressure to a different port, or for pressures beyond the internal limits stated, external pilot supply is required. External pressure is supplied to port CA in the base. For double solenoid-pilot valves, pressure must be supplied to ports CA and CB. To specify external pilot, add "014X" to the model number.



## OPERATING DATA

### SOLENOID APPROVALS:

CSA - File LR 42844-11  
FM - File J.I.2T7A3.AX

### ELECTRICAL SPECIFICATIONS: See page 23.

### RESPONSE TIME:

Energize: .022 Seconds at 100 PSIG  
De-energize .100 Seconds at 100 PSIG

### PRESSURE RANGE:

Internal Pilot Supply: 14.5 PSIG - 100 PSIG  
External Pilot Supply:  
Main Valve: 28" Hg. vacuum to 145 PSIG  
Pilot Supply: Same as internal pilot supply

### TEMPERATURE RANGE: -40° F to +115° F ambient.

### SERVICE: Valves can be used on the following properly filtered media:

Lubricated air, dry (oil free) air, vacuum, and non-corrosive, non-toxic, non-flammable dry gases. See page 130-132 of the general catalog for a list of recommended lubricants and filtration requirements for unlubricated service.

### FLOW CAPACITY:

1/8 NPTF Base: Cv = .35  
10-32 Ports with .109 I.D. Fittings Installed:  
Cv = .18

## MODEL SELECTION CHART

MODEL NUMBER		VALVE TYPE	A.N.S.I. SYMBOL	MOUNTING MEANS Add to the basic model number listed.
10-32 UNF-3B	1/8 NPTF*			
0301A4	0311A4	Single Solenoid -Pilot, 2-Position, Spring Return		00 = Valve Unit Only No Base 01 = Valve Unit With Speed Control, No Base 41 = Base, Side Ports, Individual Exhaust 46 = Base, No. 41 With Speed Control 56 = Base, Bottom Ports, Individual Exhaust 10-32 Ports Only 58 = Base, No. 56 With Speed Control 10-32 Ports Only
030114	031114	Double Solenoid- Pilot, 2-Position, Detented		WIRING OPTIONS Add to the mounting means selected. B = Hardwired, Standard D.C.

\* 1/8 is the basic size. Use this group of numbers for valve units only.  
NOTE: Ports are available tapped M5 or G 1/8.





**1/4 NPTF AND 3/8 NPTF  
MODIFIED L1 AND L2 SERIES VALVES  
FOR SPECIAL APPLICATIONS**

**numatics®**  
92088 & 92089 SERIES  
HAZ. LOC. & INTR. SAFE

92088 and 92089 valves are modified L1 and L2 Series valves. The special modification insures fast and reliable spool shifting in shut down situations. This is accomplished by a modification to the valve body that allow air from the No. 1 port to enter the return spring cavity, thus when the solenoid is deenergized, the return force of the spring is enhanced by the pressure available.

An additional modification made to these valves provides a small protection screen internally to keep any loose material in the air lines from contaminating the small orifices in the solenoid pilots.

These valves are used primarily as 3-way, normally closed valves with single pressure to the No.1 port. However, with single pressure, they may also be used as 3-way, normally open or as 4-way valves.

The valves may also be used as dual pressure 4-way if they are converted to external pilot supply. External pilot supply is also required if pressure to the No. 1 port is less than 20 PSIG. See page 16 for conversion instructions.

92088H and 92088I valves are 1/4 NPTF and Cv = 1.0.  
92089H and 92089I valves are 3/8 NPTF and Cv = 1.7.

**OPERATING DATA**

	HAZARDOUS LOCATION	INTRINSICALLY SAFE
<b>PRESSURE RANGE:</b>		
Internal Pilot Supply:	20-100 PSIG	20-100 PSIG
External Pilot Supply:		
Main Valve:	0-100 PSIG*	0-100 PSIG*
Pilot Supply:	20-100 PSIG	20-100 PSIG

\* When main valve pressure is less than 20 PSIG, the valve functions as a spring return only, without additional return force. Also, pilot pressure must be 20 PSIG minimum and equal to or greater than main valve pressure.

OTHER SPECIFICATIONS: Same as L1X, L2X, L1I and L2I.

(See pages 5, 7, 14, 16 for dimensions)

**MODEL 92088H  
1/4 NPTF HAZARDOUS LOCATION**

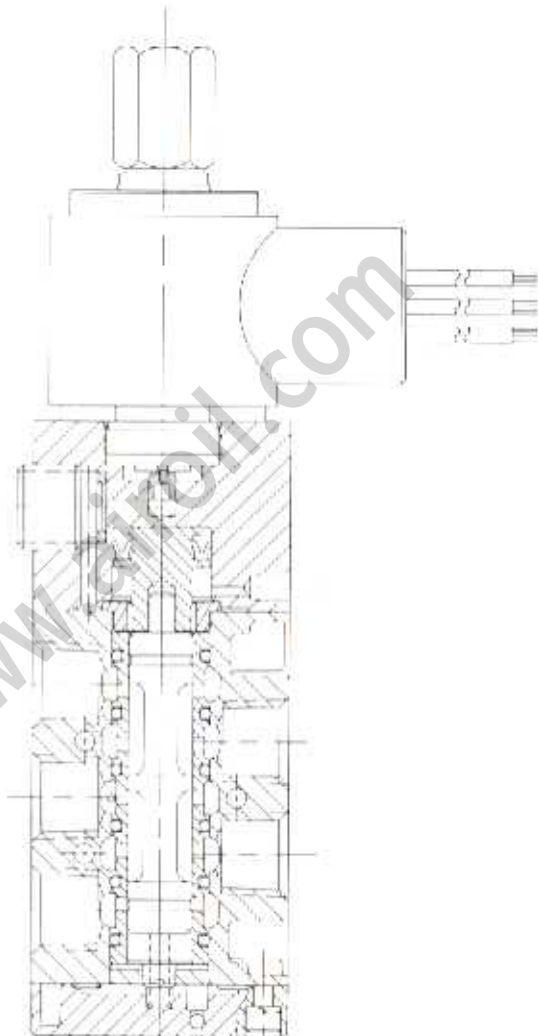

**SOLENOID APPROVALS:**

CSA - File LR 42844-11  
FM - File J.I.2T7A3.AX

**MODEL SELECTION CHART**

MODEL NUMBER	VALVE DESCRIPTION
92088H	1/4 NPTF, Single Solenoid, Pilot, Spring Return with Hazardous Location Solenoid
92088I	1/4 NPTF, Single Solenoid, Pilot, Spring Return with Intrinsically Safe Solenoid
92089H	3/8 NPTF, Single Solenoid, Pilot, Spring Return with Hazardous Location Solenoid
92089I	3/8 NPTF, Single Solenoid, Pilot, Spring Return with Intrinsically Safe Solenoid

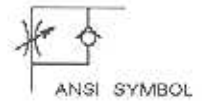

**FEATURES**

- Body swivels 360°
- Compact size
- Minimizes installation time and cost.
- Speed may be accurately controlled even at low speeds.
- Corrosion resistant
- Adjustable needle – recessed to prevent tampering.

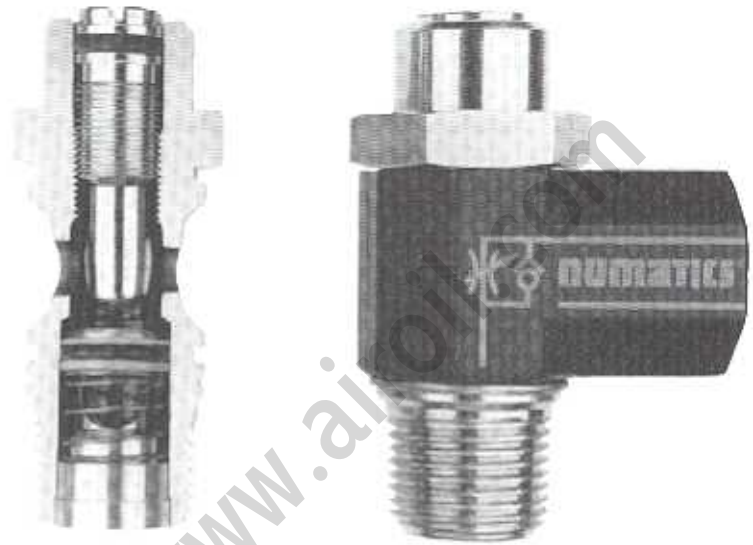

**SPECIFICATIONS**

Maximum Operating Pressure:  
175 PSIG (12 bar)

Temperature Range:  
0° F to 160° F (-18° C to 70° C)

Materials:  
Body – Anodized Aluminum  
Cartridge and Screw – Nickel Plated Brass  
Spring – Stainless Steel  
Seals – Buna N

**DIMENSIONS AND MODEL NUMBERS**

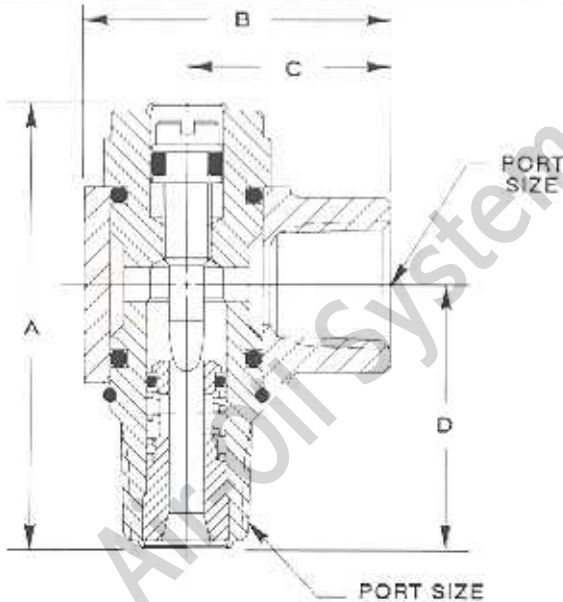

MODEL SELECTION AND DIMENSIONS						
MODEL NUMBER	PORT SIZE	FLOW CAPACITY	DIMENSIONS			
			A	B	C	D
0FCRN	10-32	Cv = .06	.79 (20)	.51 (13)	.39 (10)	.33 (8.5)
1FCRN	1/8 NPTF	Cv = .34	1.4 (35.5)	.96 (24.5)	.67 (17)	.80 (20.5)
2FCRN	1/4 NPTF	Cv = .67	1.60 (40.8)	1.28 (32.5)	.91 (23)	.97 (24.8)
3FCRN	3/8 NPTF	Cv = 1.85	2.18 (55.5)	1.45 (37)	1.02 (26)	1.04 (26.5)
4FCRN	1/2 NPTF	Cv = 2.84	2.67 (68)	1.81 (46)	1.26 (32)	1.41 (36)

Top Dimension = Inches  
Bottom Dimension  
(In Parentheses) = Millimeters

**FLOW CHARACTERISTICS (Controlled Flow)**

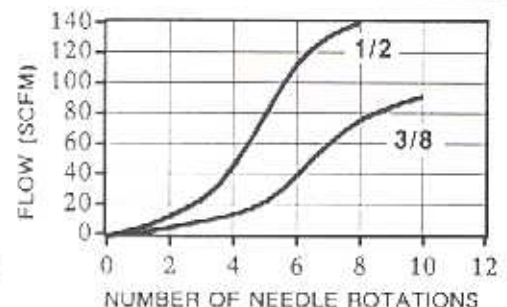
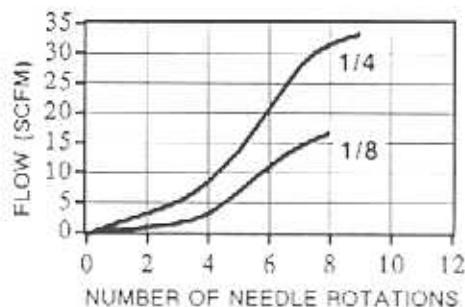
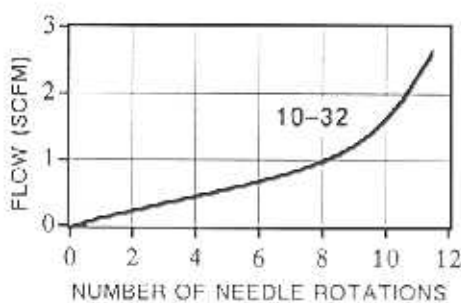



Dimension = Inches  
(In Parentheses) = Millimeters

# METERING VALVES AND INLINE FLOW CONTROL VALVES

# numatics® FLOW CONTROLS

## METERING VALVES

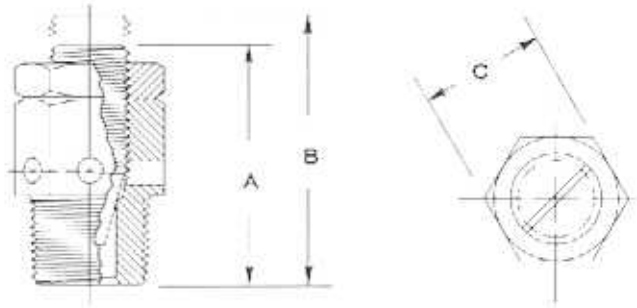

MODEL SELECTION AND DIMENSIONS						
MODEL NUMBER	A.N.S.I. SYMBOL	PORT SIZE	FLOW CAPACITY	DIMENSIONS		
				A	B	C
MV-05		1/8 NPTF	Cv = .46	.90 (23)	1.09 (28)	.44 (11.2)
MV-10		1/4 NPTF	Cv = .80	1.16 (30)	1.44 (37)	.50 (12.7)
MV-25		1/4 NPTF	Cv = 1.80	1.37 (35)	1.50 (38)	.69 (17.5)
MV-37		3/8 NPTF	Cv = 1.80	1.31 (33)	1.50 (38)	.69 (17.5)
MV-50		1/2 NPTF	Cv = 3.38	1.62 (41)	2.00 (51)	.87 (22.1)
MV-75		3/4 NPTF	Cv = 8.34	2.00 (51)	2.37 (60)	1.06 (26.9)
MV-100		1 NPTF	Cv = 8.34	3.00 (76)	3.50 (89)	1.37 (34.8)

## IN-LINE FLOW CONTROL VALVES

### 1FC1 AND 2FC1

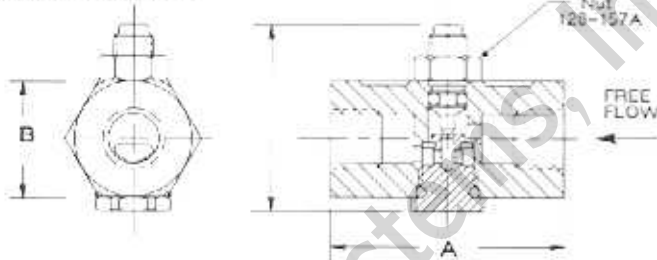

**OPTIONAL KNURLED KNOB**  
Adjustment, add .56" (14.7 mm) to height dimensions

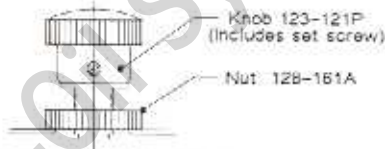

### FC2 AND FC3

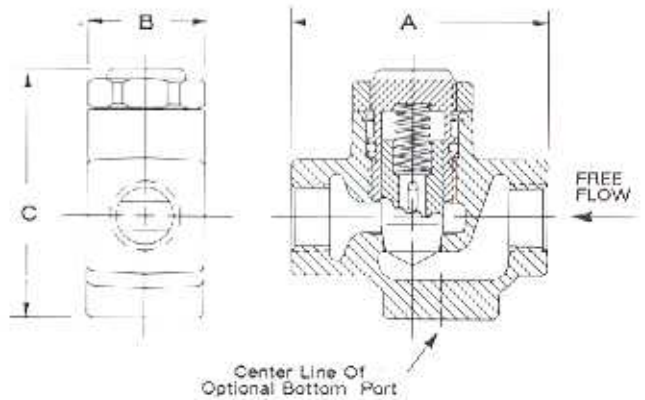

MODEL SELECTION AND DIMENSIONS							
MODEL NUMBER	A.N.S.I. SYMBOL	PORT SIZE	FLOW CAPACITY		DIMENSIONS		
			Free	Controlled	A	B	C
1FC1		1/8 NPTF	Cv = .22	Cv = .16	1.50 (38)	.75 (19)	1.08 (27)
2FC1		1/4 NPTF	Cv = .22	Cv = .16	1.50 (38)	.75 (19)	1.08 (27)
1FC1K		1/8 NPTF	Cv = .22	Cv = .16	1.50 (38)	.75 (19)	1.66 (42)
2FC1K		1/4 NPTF	Cv = .22	Cv = .16	1.50 (38)	.75 (19)	1.66 (42)
2FC2		1/4 NPTF	Cv = 2.3	Cv = 2.0	2.34 (59)	1.06 (27)	2.21 (56)
3FC2		3/8 NPTF	Cv = 2.7	Cv = 2.4	2.34 (59)	1.06 (27)	2.21 (56)
4FC3		1/2 NPTF	Cv = 6.0	Cv = 5.5	3.28 (83)	1.50 (38)	3.17 (81)
5FC3		3/4 NPTF	Cv = 7.5	Cv = 6.0	3.28 (83)	1.50 (38)	3.17 (81)

**FlexiBlok® SERIES COALESCER REGULATOR**

A complete air preparation package for dry service applications. Air passes through .9 micron pleated pre-filter then 0.3 micron coalescing filter. Pressure is reduced by exiting through a diaphragm operated regulator. Is adjustable from 0-125 PSI. All units include a Pressure Gauge and CircleVision® sight bowls. CircleVision combines the security of an interior metal bowl with the convenience of 360° viewing in an exterior polycarbonate bowl.

SERIES	PORTS	MODEL
30	1/4 Ports	C30D-02CD
30	3/8 Ports	C30D-03CD
30	1/2 Ports	C30D-04CD

**FlexiBlok® SERIES PARTICULATE FILTER**

Five micron particulate filter for removal of high water concentrations or removal of large particulates. A baffle spins water to I.D. of bowl where gravity drains. Air then passes through the element removing all contaminants above 5 micron from air line. 30 Series models can be manifold mounted in front of the Series 30 Coalescer Regulator for applications requiring modular connection. All units include CircleVision® sight bowls. CircleVision combines the security of an interior metal bowl with the convenience of 360° viewing in an exterior polycarbonate bowl. For automatic drains, see options below.

SERIES	PORTS	MODEL
10	1/4 Ports	F10B-02C
20	3/8 Ports	F20B-03C
30	1/2 Ports	F30B-04C

**FlexiBlok® SERIES REGULATOR**

Takes high pressure air and reduces to accurate working pressure. Saves in cost of compressed air and wear of downstream components. All regulators are adjustable from 0-125 PSIG. A gauge is included.

SERIES	PORTS	MODEL
10	1/4 Ports	R10R-02G
20	3/8 Ports	R20R-03G
30	1/2 Ports	R30R-04G

**OPTIONS****FlexiBlok® SERIES SHUT-OFF VALVE**

Shut-off valves mount directly to the inlet side of similar series above components. 3-way function relieves downstream pressure when shut off. Unit can be locked for security.

SERIES	INLET PORT	PART NO.
10	1/4 Ports	VK10-02
20	3/8 Ports	VK20-03
30	1/2 Ports	VK30-04

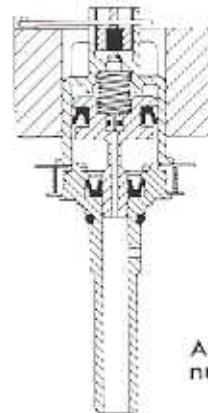
**FlexiBlok® AUTO FLOAT DRAIN**

Automatically removes collected water from filter or coalescer regulator.

Add suffix A to above model numbers or order separately as part No. AKF00

Add suffix V to above model numbers or order separately by individual part number.

*For a complete description of these products or other air preparation components, consult individual product line catalogs or your local Numatics distributor.*



# INTRINSICALLY SAFE ELECTRICAL SPECIFICATIONS

All Intrinsically Safe valves shown in this catalog use solenoid No. 226-885B and all valve installations must comply with the same electrical specifications. Solenoid No. 226-885B has both CSA and FM entity approval - This means the valve installation is considered safe if it is installed in accordance with the parameters stated below. This allows any safety barrier to be used that complies with these parameters.

Factory Mutual defines the entity concept as follows: "The entity concept allows interconnection of intrinsically safe apparatus to associated apparatus not specifically examined in such combination. The criteria for interconnection is that the voltage and the current which intrinsically safe apparatus can receive and remain intrinsically safe, considering faults, must be equal to or greater than the voltage ( $V_{oc}$  or  $V_t$ ) and current ( $I_{sc}$  or  $I_t$ ) levels which can be delivered by the associated apparatus, considering faults and applicable factors. In addition, the maximum unprotected capacitance ( $C_i$ ) and inductance ( $L_i$ ) of the intrinsically safe apparatus, including interconnecting wiring, must be equal to or less than the capacitance and inductance which can be safely connected to associated apparatus. Wiring connections must be per ISA RP 12.6 instructions."

### SAFETY BARRIER SPECIFICATIONS

1. Maximum safe area voltage not to exceed 250V RMS.
2. Connect per barrier manufacturers instructions.
3. Certified passive zener barrier

4.

MAXIMUM ENTITY PARAMETERS FOR FACTORY MUTUAL				
V max. (Vdc)	I max. (ma)	GROUP	$C_i$	$L_i$
22	100	A, B	0	0
28	125	C, D	0	0

### SOLENOID / VALVE SPECIFICATIONS

1. Maximum inductance of coil only, not to exceed 370 mh. Maximum inductance of solenoid pilot when mounted on a valve body not to exceed 630 mh.
2. Coil Wattage - .5 watts maximum.
3. CSA Certified Data  
 "This solenoid pilot operator is intrinsically safe for Class I, Groups A, B, C, and D; Class II, Groups E, F, and G; and Class III, when connected through a certified passive zener barrier rated 22 VDC max. and 150 ohm min. and for Class I, Groups C and D; Class II, Groups E, F, and G; and Class III, when connected through a certified passive zener barrier rated 28 VDC max. and 150 ohm min."

### SOLENOID APPROVALS:

CSA - File LR42844-11  
 FM - File J.I.2T7A3.AX

All approvals apply to Division I which states that the hazardous atmosphere is expected to be present continuously. For Division II applications, these intrinsically safe valves may be installed without a barrier and with a 24 VDC power supply. Division II states that the hazardous atmosphere may only occur occasionally or under abnormal conditions.

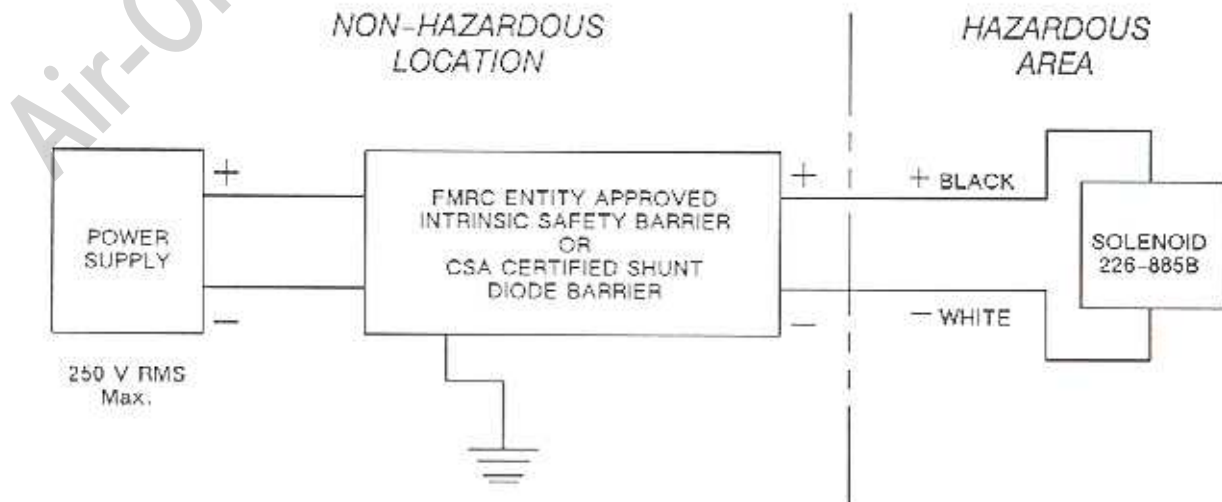

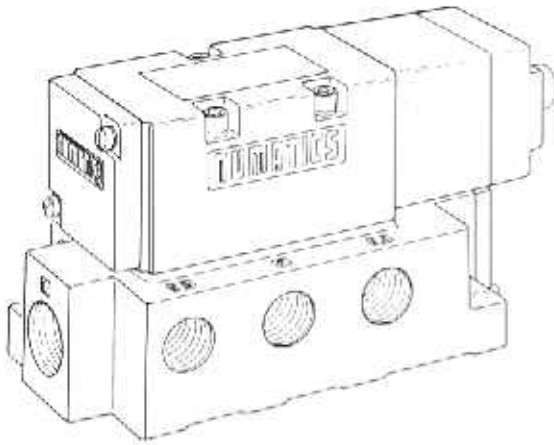

#### U.S.A.

NUMATICS, INC.  
1450 N. Milford Road  
Highland, MI 48357-4560  
Phone: (248) 887-4111  
FAX: (248) 887-9190

NUMATICS, INC.  
Actuator Division  
308 Mallory Station Rd.  
Franklin, TN 37067  
Phone: (615) 771-1200  
FAX: (615) 771-1201

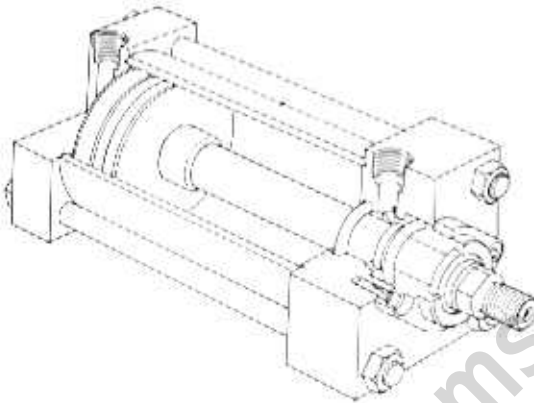

#### CANADA:

NUMATICS, LTD.  
363 Sovereign Road  
London, Ontario, Canada N6M 1A3  
Phone: (519) 452-1777  
FAX: (519) 452-3995

#### EUROPE:

NUMATICS GmbH  
Otto-von-Guericke Str. 14  
53757 St. Augustin  
Germany  
Phone: (02241) 31600  
FAX: (02241) 3160-40

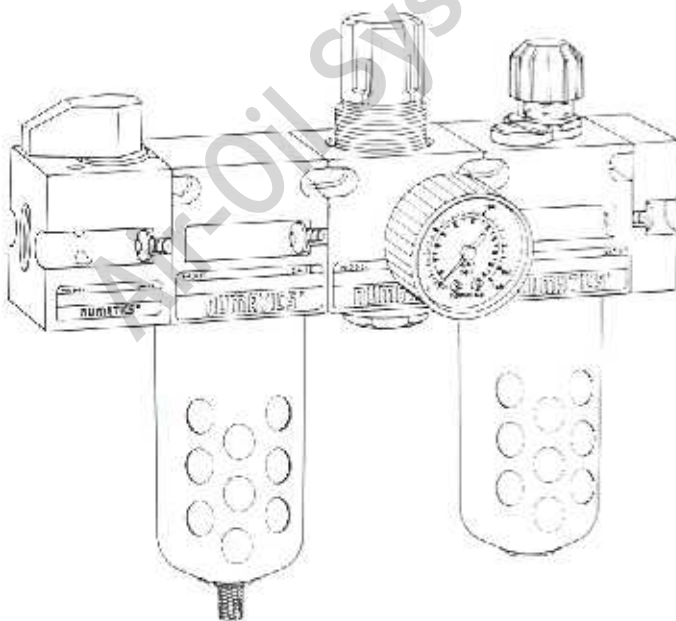

#### ENGLAND:

NUMATICS LIMITED  
P.O. Box 18  
Leighton Buzzard, Beds  
England LU7 7DJ  
Phone: 0525-370735  
FAX: 0525-382567