

air prep

Lockout Valve

Series



numatics®

EMERSON.
Industrial Automation

www.numatics.com

NUMATICS®

Numatics, Inc. is a leading manufacturer of pneumatic products and motion control products. Our broad spectrum of standard, custom developed products and application components, have made a significant impact on pneumatic innovation as well as pneumatic and motion control technology. Our company has an extensive history of generating innovative concepts and technological breakthroughs. Many of today's standard features in pneumatic technology were industry firsts from Numatics. We continue our innovative approach to product development by developing electric motion control solutions and enhancing our embedded Fieldbus and I/O products to continually meet and solve our customer's application requirements.



Today Numatics is proud to be a part of the Industrial Automation Division of Emerson Electric Co.

Emerson (NYSE: EMR) is a global company that brings together technology and engineering to provide innovative solutions for customers in a wide range of industrial, commercial, and consumer markets.

Numatics, along with the vast resources of the Emerson organization, will assure that our proud history of innovation and service will continue to meet the needs of our global customers.

Table of Contents



Lockout Valve Series

Features and Benefits	2
Inline Lockout and Slo Start™ Valves VL / VT32	3
Inline Lockout and Slo Start™ Valves VL / VT40	4
Inline Lockout and Slo Start™ Valves VL / VT42	5
Inline Lockout and Slo Start™ Valves VL / VT52	6
FLEXIBLOK ® Modular-Lockout and Shut Off Valves MVL / MVT / VSL 32	7
FLEXIBLOK ® Modular-Lockout and Shut Off Valves MVL / MVT / VSL 42	8
Accessories: Mufflers and Scissor "Trades" Lock	9

Air-Oil Systems, Inc. www.airoil.com



Numatics Lockout and Shut Off Valves



Lockout valves prevent unauthorized pressurization of an air system during service or maintenance. Numatics lockout valves employ a unique, one piece center spool design that accommodates a user-supplied padlock in the closed position. When locked in the closed position, the system controlled by the lockout valve cannot be operated until the padlock is removed. Numatics lockout valves are available in several different designs, including manual, Slo-Start™, and Modular. Each lockout valve is equipped with an emergency shutoff feature that quickly exhausts the downstream air to atmosphere. An additional feature of the Slo-Start™ valves is their capability to gradually ramp up the downstream pressure before opening to full flow conditions.

Numatics VL / VT, MVL / MVT Inline and Modular Lockout Valves

Recommended use:

Install the **Lockout Valve downstream** of FRL assembly or selected air preparation components so its exhaust capacity is not restricted by any upstream components.

Features:

- Emergency shut off – Full flow quick exhaust of downstream pressure
- Meets OSHA specifications
- Bright Yellow body with Red knob is easily identified as a lockout device
- Integrated hole in valve spool for Scissor “Trades” lock
- Sturdy construction
- Durable and long lasting
- Slo-Start™ feature allows operator to turn spool CCW to “ON” position gradually ramping up downstream pressure, prolonging the life of pneumatic components

Numatics VSL Modular Shut Off Valves

Recommended use:

Install the **Shut Off Valve upstream** of an FRL assembly or selected air preparation components. Restricted exhaust capacity prevents potential damage to FRL or air preparation components due to excessive pressure drop in the reverse flow direction. Provides a method to exhaust FRL or air preparation assembly, when components require service.

Features:

- Shut Off Valve – Restricted flow exhaust of downstream pressure
- Meets OSHA specifications
- Grey body with Red knob
- VSL32 with threaded exhaust provides alternative to VS32 Slide Plate style
- Integrated hole in valve spool for Scissor “Trades” lock
- Sturdy construction
- Durable and long lasting

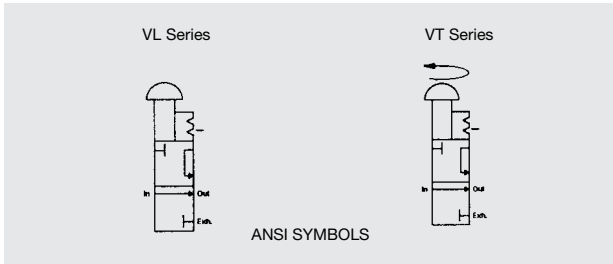

Inline Manual Lockout Valves

VL32 Standard Series / VT32 Slo-Start™ Feature

- High exhaust capability
- Detented spool
- Low-friction startup
- Meets OSHA specifications
- Surface mountable

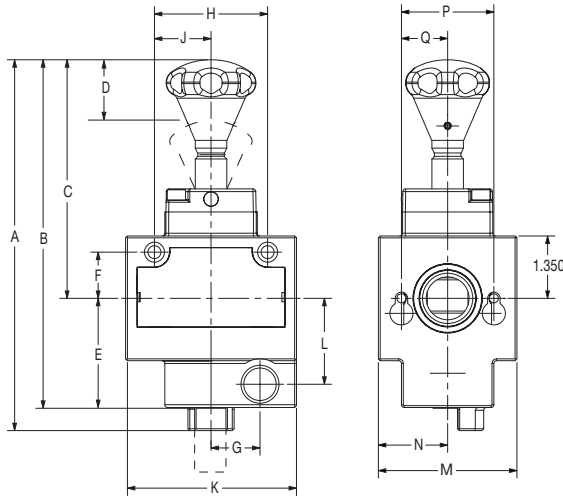

VL Series Shown

Specifications

Temperature Range: 40°F to 120° F (4.4° C to 46.9° C)
 Maximum Pressure: 150 PSIG (10 bar)
 Flow Media: filtered air
 Weight: VL32 Series 2.70 lbs (1.23 kg)
 VT32 Series 3.05 lbs (1.39 kg)

Cv Ratings

MODEL NUMBER	Cv IN-OUT	Cv OUT-EXH
VL32N03Y / VT32N03Y	5.0	5.5
VL32N04Y / VT32N04Y	6.0	6.0
VL32N06Y / VT32N06Y	8.3	6.0

Dimensions in inches (mm)

MODEL	A	B	C	D	E	F	G	H
VL32	8.03 (204.0)	7.55 (191.8)	5.17 (131.3)	.960 (24.4)	2.36 (59.9)	1.0 (25.4)	1.06 (26.9)	8.03 (62.2)
VT32	9.34 (237.2)	8.86 (225.0)	6.47 (164.3)	1.05 (26.7)	2.36 (59.9)	1.0 (25.4)	1.06 (26.9)	1.00 (25.4)
	J	K	L	M	N	P	Q	
VL32	1.225 (31.1)	3.66 (93.0)	1.86 (47.2)	3.00 (76.2)	1.50 (38.1)	2.00 (50.8)	1.00 (25.4)	
VT32	1.225 (31.1)	3.66 (93.0)	1.86 (47.2)	3.00 (76.2)	1.50 (38.1)	2.00 (50.8)	1.00 (25.4)	

How To Order

V L 32 N 03 Y

Model
 L = Standard
 T = Slo-Start™ Feature

Threads
 N = NPTF
 G = G Tap (BSPP)

Port Size
 03 = 3/8 in/out, 1/2 exh.
 04 = 1/2 in/out, 1/2 exh.
 06 = 3/4 in/out, 1/2 exh.

Options
 A = Metal Muffler (i.e. VL32N04AY)
 B = Scissor "Trades" Lock (i.e. VL32N04BY)



Lockout Valve Series

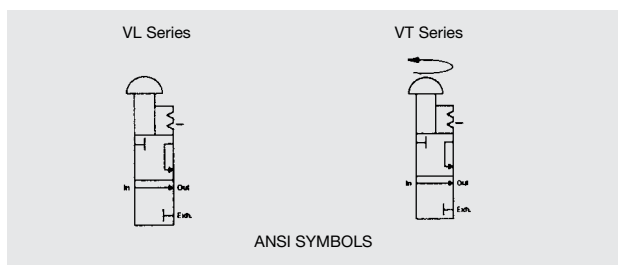

Inline Manual Lockout Valves VL40 Standard Series / VT40 Slo-Start™ Feature

- High exhaust capability
- Detented spool
- Low-friction startup
- Meets OSHA specifications
- Surface mountable

Specifications

Temperature Range: 40°F to 120° F (4.4° C to 46.9° C)
 Maximum Pressure: 150 PSIG (10 bar)
 Flow Media: filtered air
 Weight: VL40 Series 4.40 lbs (2.00 kg)
 VT40 Series 5.00 lbs (2.27 kg)

Cv Ratings

MODEL NUMBER	Cv IN-OUT	Cv OUT-EXH
VL40N06Y / VT40N06Y	13.5	11.0
VL40N08Y / VT40N08Y	18.2	14.9
VL40N10Y / VT40N10Y	19.1	14.9
VL40N12Y / VT40N12Y	20.3	16.3

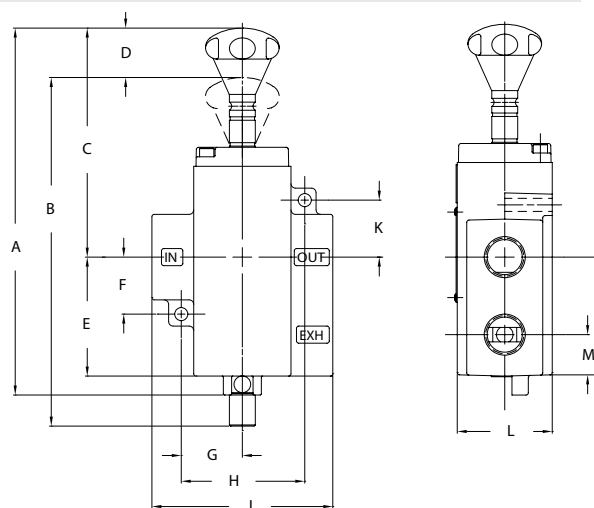

VL Series Shown

Dimensions in inches (mm)

MODEL	A	B	C	D	E	F	G
VL40	9.75 (247.7)	9.27 (235.5)	6.12 (155.4)	1.30 (33)	3.13 (79.5)	1.50 (38.1)	1.62 (41.3)
VT40	11.45 (290.8)	10.97 (278.6)	7.82 (198.6)	1.30 (33)	3.13 (79.5)	1.50 (38.1)	1.62 (41.3)
	H	J	K	L	M	N	
VL40	3.25 (82.6)	4.76 (120.9)	1.50 (38.1)	2.50 (63.5)	1.09 (27.7)	3.13 (79.5)	
VT40	3.25 (82.6)	4.76 (120.9)	1.50 (38.1)	2.50 (63.5)	1.09 (27.7)	3.13 (79.5)	

How To Order

V L 40 N 06 Y

Model

L = Standard
 T = Slo-Start™ Feature

Threads

N = NPTF
 G = G Tap (BSPP)

Port Size

06 = 3/4 in/out, 3/4 exh.
 08 = 1 in/out, 1 exh.
 10 = 1 1/4 in/out, 1 exh.
 12 = 1 1/2 in/out, 1 exh.

Options

A = Metal Muffler (i.e. VL40N08AY)
 B = Scissor “Trades” Lock (i.e. VL40N08BY)

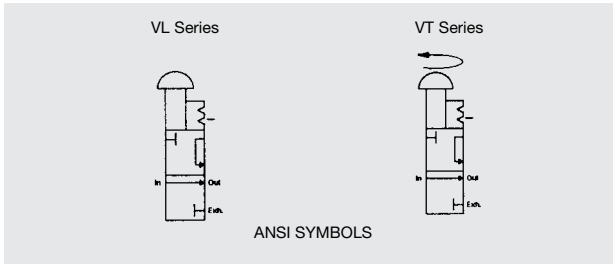

Inline Manual Lockout Valves VL42 Standard Series / VT42 Slo Start™ Feature

- High exhaust capability
- Detented spool
- Low-friction startup
- Meets OSHA specifications
- Surface Mountable

Specifications

Temperature Range: 40°F to 120° F (4.4° C to 46.9° C)
 Maximum Pressure: 250 PSIG (17 bar) (42 Series Only)
 Flow Media: filtered air
 Weight: VL42 Series: 4.95lbs (2.25 kg)
 VT42 Series: 5.5 lbs (2.5 kg)

Cv Ratings

MODEL NUMBER	Cv IN-OUT	Cv OUT-EXH
VL42N06Y / VT42N06Y	11.5	9.0
VL42N08Y / VT42N08Y	12.5	10.0

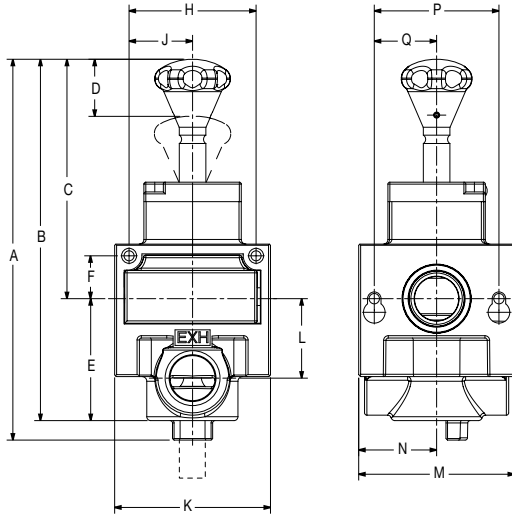

VL Series Shown

Dimensions in inches (mm)

MODEL	A	B	C	D	E	F	G	H	J	K	L	M
VL42	9.78 (248.4)	9.28 (235.7)	6.1 (154.9)	1.34 (34.0)	3.13 (80.0)	1.10 (28.0)	0.00 (0.0)	3.26 (83.5)	1.63 (41.0)	4.00 (102.0)	2.04 (52.0)	4.00 (102.0)
VT42	11.48 (291.6)	10.98 (278.9)	7.85 (199.4)	1.34 (34.0)	3.13 (80.0)	1.10 (28.0)	0.00 (0.0)	3.26 (83.5)	1.63 (41.0)	4.00 (102.0)	2.04 (52.0)	4.00 (102.0)
	N	P	Q									
VT42	2.00 (51.0)	3.20 (81.0)	1.60 (41.0)									
VT42	2.00 (51.0)	3.20 (81.0)	1.60 (41.0)									

How To Order

V L 42 N 06 Y

Model
 L = Standard
 T = Slo-Start™ Feature

Port Size
 06 = 3/4 in/out, 1 exh.
 08 = 1 in/out, 1 exh.

Options
 A = Metal Muffler (i.e. VL42N08AY)
 B = Scissor "Trades" Lock (i.e. VT42N08BY)

Threads
 N = NPTF
 G = G Tap (BSPP)



Lockout Valve Series

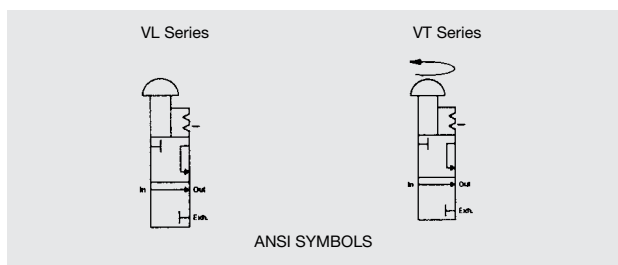

Inline High Flow Manual Lockout Valves VL52 Standard Series / VT52 Slo-Start™ Feature

- High flow
- High exhaust capability
- Detented spool
- Meets OSHA specifications
- Surface mountable

Specifications

Temperature Range: 40°F to 120° F (4.4° C to 46.9° C)
 Maximum Pressure: 150 PSIG (10 bar)
 Flow Media: filtered air
 Weight: VL52 Series 4.125 lbs (1.87 kg)
 VT52 Series 5.500 lbs (2.5 kg)

Cv Ratings

MODEL NUMBER	Cv IN-OUT	Cv OUT-EXH
VL52N12Y / VT52N12Y	24	16
VL52N16Y / VT52N16Y	24	16

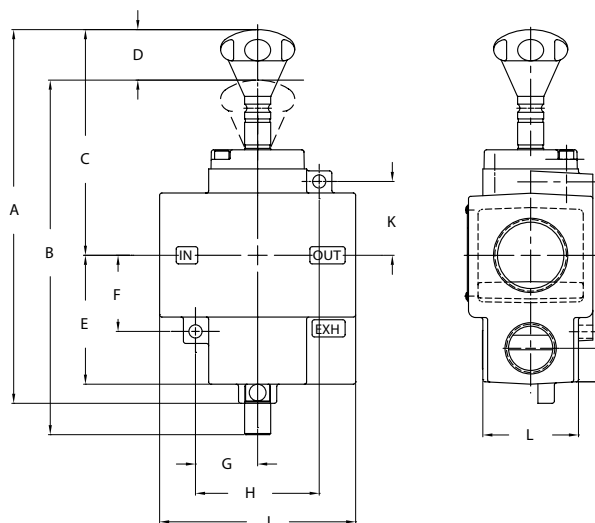

VL Series Shown

Dimensions in inches (mm)

MODEL	A	B	C	D	E	F	G
VL52	9.77 (248.2)	9.27 (235.5)	5.90 (149.9)	1.32 (33.5)	3.38 (85.9)	2.00 (50.8)	1.63 (41.4)
VT52	11.47 (291.3)	10.97 (278.6)	7.59 (192.8)	1.32 (33.5)	3.38 (85.9)	2.00 (50.8)	1.63 (41.4)
	H	J	K	L	M	N	
VL52	3.24 (82.6)	5.13 (120.9)	1.92 (38.1)	2.50 (63.5)	0.88 (27.7)	3.31 (79.5)	
VT52	3.24 (82.6)	5.13 (120.9)	1.92 (38.1)	2.50 (63.5)	0.88 (27.7)	3.31 (79.5)	

How To Order

V L 52 N 12 Y

Model

L = Standard
 T = Slo-Start™ Feature

Threads

N = NPTF
 G = G Tap (BSPP)

Port Size

12 = 1 1/2 in/out, 1 exh
 16 = 2 in/out, 1 exh

Options

A = Metal Muffler (i.e. VL52N12AY)
 B = Scissor "Trade" Lock (i.e. VL52N12BY)

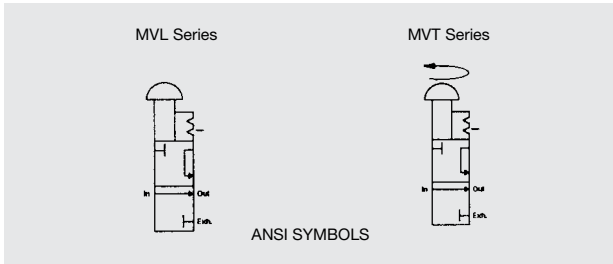

FLEXIBLOK® Modular Lockout and Shut Off Valves

MVL32 Standard Series / MVT32 Slo-Start™ Feature VSL Shut Off Valve Restricted Exhaust

- High exhaust capability - MVL/MVT
- Detented spool
- Low-friction startup
- Meets OSHA specifications
- Surface mountable
- Modular adaptable to Numatics **FLEXIBLOK®** 32 series 1/2" & 3/4" products
- VSL Shut Off Valve Restricted Exhaust - Grey color

Specifications

Temperature Range: 40°F to 120° F (4.4° C to 46.9° C)
 Maximum Pressure: 150 PSIG (10 bar)
 Flow Media: filtered air
 Weight: MVL32 Series 2.70 lbs (1.23 kg)
 MVT32 Series 3.05 lbs (1.39 kg)
 VSL32 Series 2.70 lbs (1.23 kg)

Cv Ratings

MODEL NUMBER	Cv IN-OUT	Cv OUT-EXH
MVL32-04Y / MVT32-04Y	6.0	6.0
MVL32-06Y / MVT32-06Y	8.3	6.0
VSL32-04	6.0	0.3
VSL32-06	8.3	0.3

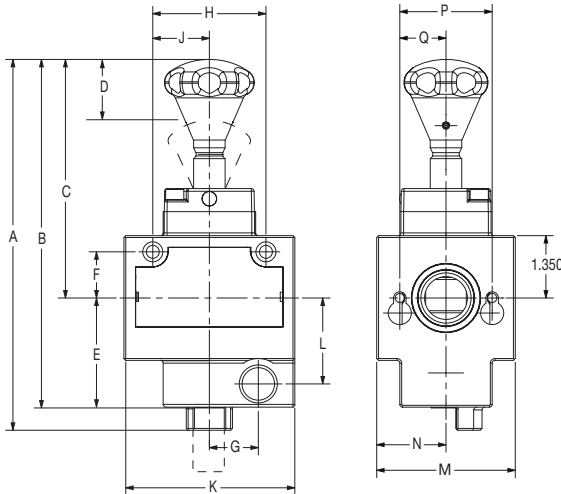

MVL Series Shown

Dimensions in inches (mm)

MODEL	A	B	C	D	E	F	G	H
MVL32 / VSL32	8.03 (204.0)	7.55 (191.8)	5.17 (131.3)	.960 (24.4)	2.36 (59.9)	1.0 (25.4)	1.06 (26.9)	8.03 (62.2)
MVT32	9.34 (237.2)	8.86 (225.0)	6.47 (164.3)	1.05 (26.7)	2.36 (59.9)	1.0 (25.4)	1.06 (26.9)	1.00 (25.4)
	J	K	L	M	N	P	Q	
MVL32 / VSL32	1.225 (31.1)	3.66 (93.0)	1.86 (47.2)	3.00 (76.2)	1.50 (38.1)	2.00 (50.8)	1.00 (25.4)	
MVT32	1.225 (31.1)	3.66 (93.0)	1.86 (47.2)	3.00 (76.2)	1.50 (38.1)	2.00 (50.8)	1.00 (25.4)	

How To Order - Lockout Valve

MV L 32 - 04 Y

Model
 L = Standard
 T = Slo-Start™ Feature

Threads
 - = NPTF
 G = G Tap (BSPP)

Options

A = Metal Muffler (i.e. MVL32-04AY)
 B = Scissor "Trades" Lock (i.e. MVL32-04BY)

How To Order - Shut Off Valve

V S L 32 - 04

Model
 VSL = Shut Off Valve
 Restricted Exhaust

Threads
 - = NPTF
 G = G Tap (BSPP)

Options

M = Metal Muffler (i.e. VSL32-04M)

Port Size
 04 = 1/2 in/out, 10-32 exh.
 06 = 3/4 in/out, 10-32 exh.



Lockout Valve Series

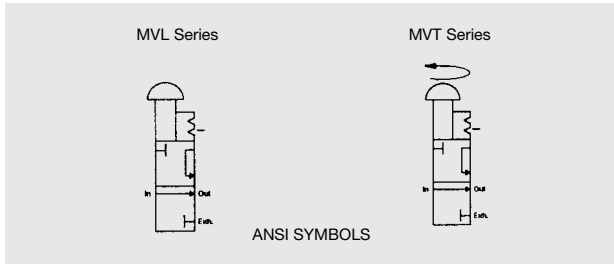

FLEXIBLOK® Modular Lockout and Shut Off Valves

MVL42 Standard Series / MVT42 Slo-Start™ Feature VSL Shut Off Valve Restricted Exhaust

- High exhaust capability - MVL/MVT
- Detented spool
- Low-friction startup
- Meets OSHA specifications
- Surface mountable
- Modular adaptable to Numatics **FLEXIBLOK®** 42 series 3/4" & 1" products
- VSL Shut Off Valve Restricted Exhaust - Grey color

Specifications

Temperature Range: 40°F to 120° F (4.4° C to 46.9° C)
 Maximum Pressure: 250 PSIG (17 bar) (42 Series Only)
 Flow Media: filtered air
 Weight: MVL42 Series 4.95 lbs (2.25 kg)
 MVT42 Series 5.5 lbs (2.5 kg)
 VSL42 Series 4.95 lbs (2.25 kg)

Cv Ratings

MODEL NUMBER	Cv IN-OUT	Cv OUT-EXH
MVL42-06Y / MVT42-06Y	11.5	9.0
MVL42-08Y / MVT42-08Y	12.5	10.0
VSL42-06	11.5	0.3
VSL42-08	12.5	0.3

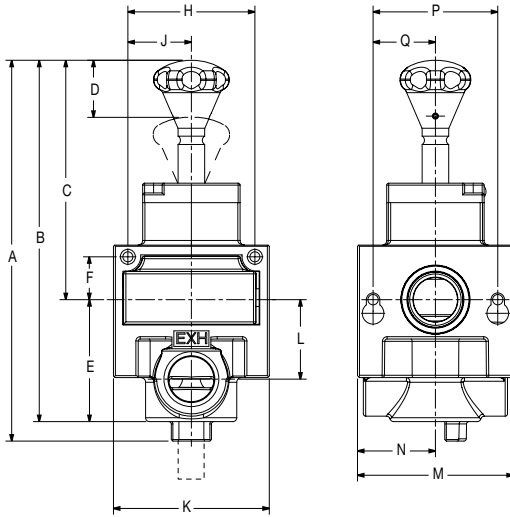

MVL Series Shown

Dimensions in inches (mm)

MODEL	A	B	C	D	E	F	G	H
MVL42 / VSL42	9.78 (248.4)	9.28 (235.7)	6.1 (154.9)	1.34 (34.0)	3.13 (80.0)	1.10 (28.0)	0.00 (0.0)	3.26 (83.5)
MVT42	11.48 (291.6)	10.98 (278.9)	7.85 (199.4)	1.34 (34.0)	3.13 (80.0)	1.10 (28.0)	0.00 (0.0)	3.26 (83.5)
	J	K	L	M	N	P	Q	
MVL42 / VSL42	1.63 (41.0)	4.00 (102.0)	2.04 (52.0)	4.00 (102.0)	2.00 (51.0)	3.20 (81.0)	1.60 (41.0)	
MVT42	1.63 (41.0)	4.00 (102.0)	2.04 (52.0)	4.00 (102.0)	2.00 (51.0)	3.20 (81.0)	1.60 (41.0)	

How To Order - Lockout Valve

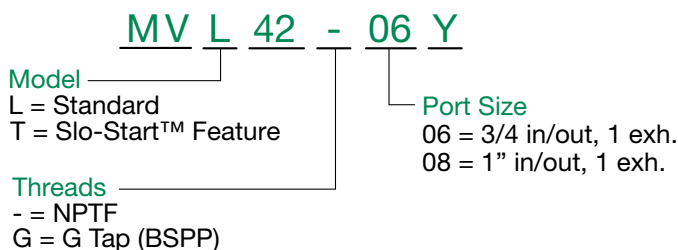

Options

A = Metal Muffler (i.e. MVL42-08AY)
 B = Scissor "Trades" Lock (i.e. MVL42-08BY)

How To Order - Shut Off Valve

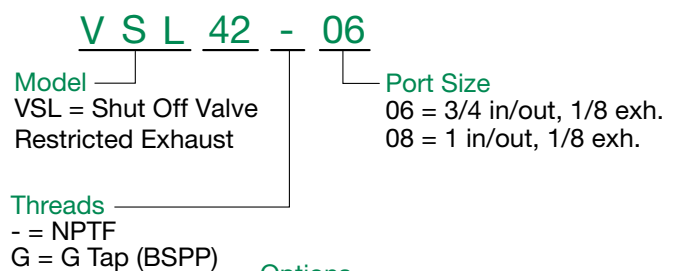

Options

M = Metal Muffler (i.e. VSL42-08M)



M Series Metal Air Silencers

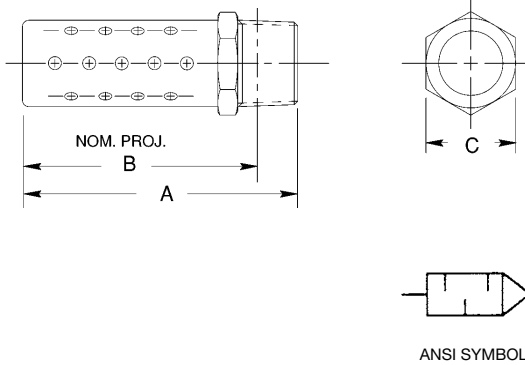

NPTF Male Dimensions

Model	NPTF	A	B	C	cv
M1MN	1/8	1.38 (34.9)	1.22 (31.0)	0.44 (11.1)	1.17
M2MN	1/4	1.75 (44.5)	1.53 (38.9)	0.56 (14.3)	2.54
M3MN	3/8	2.25 (57.2)	2.00 (50.8)	0.69 (17.5)	5.08
M4MN	1/2	2.72 (69.1)	2.41 (61.1)	0.88 (22.2)	7.32
M5MN	3/4	3.16 (80.2)	2.81 (71.4)	1.06 (27.0)	13.87
M6MN	1	3.88 (98.4)	3.47 (88.1)	1.31 (33.3)	19.53
M7MN	1 1/4	4.50 (114.3)	4.16 (105.6)	1.69 (42.9)	28.32
M8MN	1 1/2	5.00 (127.0)	4.59 (116.7)	2.00 (50.8)	38.09
M9MN	2	5.50 (139.7)	5.06 (128.6)	2.38 (60.3)	52.73

BSPT Male Dimensions

Model	NPTF	A	B	C	cv
M1MB	1/8	1.38 (34.9)	1.22 (31.0)	0.44 (11.1)	1.17
M2MB	1/4	1.75 (44.5)	1.53 (38.9)	0.56 (14.3)	2.54
M3MB	3/8	2.25 (57.2)	2.00 (50.8)	0.69 (17.5)	5.08
M4MB	1/2	2.72 (69.1)	2.41 (61.1)	0.88 (22.2)	7.32
M5MB	3/4	3.16 (80.2)	2.81 (71.4)	1.06 (27.0)	13.87
M6MB	1	3.88 (98.4)	3.47 (88.1)	1.31 (33.3)	19.53

P Series Porous Bronze Air Silencers

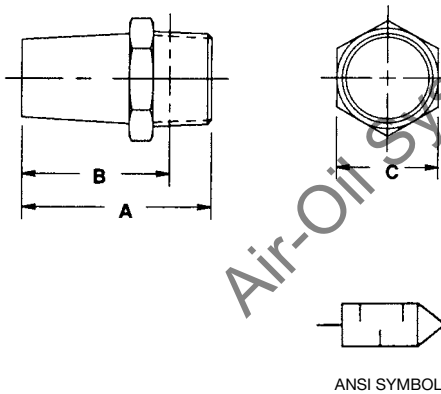

NPTF Male Dimensions

Model	NPTF	A	B	C	cv
P0MN	10-32	0.75 (19.1)	0.62 (15.7)	0.38 (9.5)	0.23
P1MN	1/8	0.84 (21.4)	0.69 (17.5)	0.44 (11.1)	1.07
P2MN	1/4	1.20 (30.6)	0.97 (24.6)	0.56 (14.3)	1.78
P3MN	3/8	1.45 (36.7)	1.20 (30.6)	0.69 (17.5)	2.30
P4MN	1/2	1.89 (48.0)	1.58 (40.1)	0.88 (22.2)	5.66
P5MN	3/4	2.12 (54.0)	1.78 (45.2)	1.06 (27.0)	9.67
P6MN	1	2.84 (72.2)	2.44 (61.9)	1.31 (33.3)	14.06
P7MN	1 1/4	3.44 (87.3)	3.00 (76.2)	1.69 (42.9)	20.51
P8MN	1 1/2	4.00 (101.6)	3.56 (90.5)	2.00 (50.8)	29.10
P9MN	2	4.75 (120.7)	4.31 (109.5)	2.38 (60.3)	44.92

BSPT Male Dimensions

Model	NPTF	A	B	C	cv
P1MB	1/8	0.84 (21.3)	0.69 (17.5)	0.44 (11.1)	1.07
P2MB	1/4	1.20 (30.5)	0.97 (24.6)	0.56 (14.3)	1.78
P3MB	3/8	1.45 (36.8)	1.20 (30.5)	0.69 (17.5)	2.30
P4MB	1/2	1.89 (48.0)	1.58 (40.1)	0.88 (22.2)	5.66
P5MB	3/4	2.12 (53.9)	1.78 (45.2)	1.06 (27.0)	9.67
P6MB	1	2.84 (72.1)	2.44 (62.0)	1.31 (33.3)	14.06

Scissor "Trades" Lock

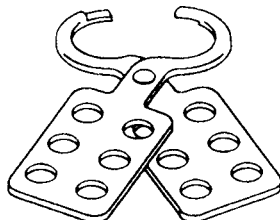

The Scissor or "Trades" Lock clips into the lockout valve and can be locked with up to six locks, allowing maximum security.

Model Number: VB-1

NUMATICS

*World Class Supplier
of Pneumatic Components*

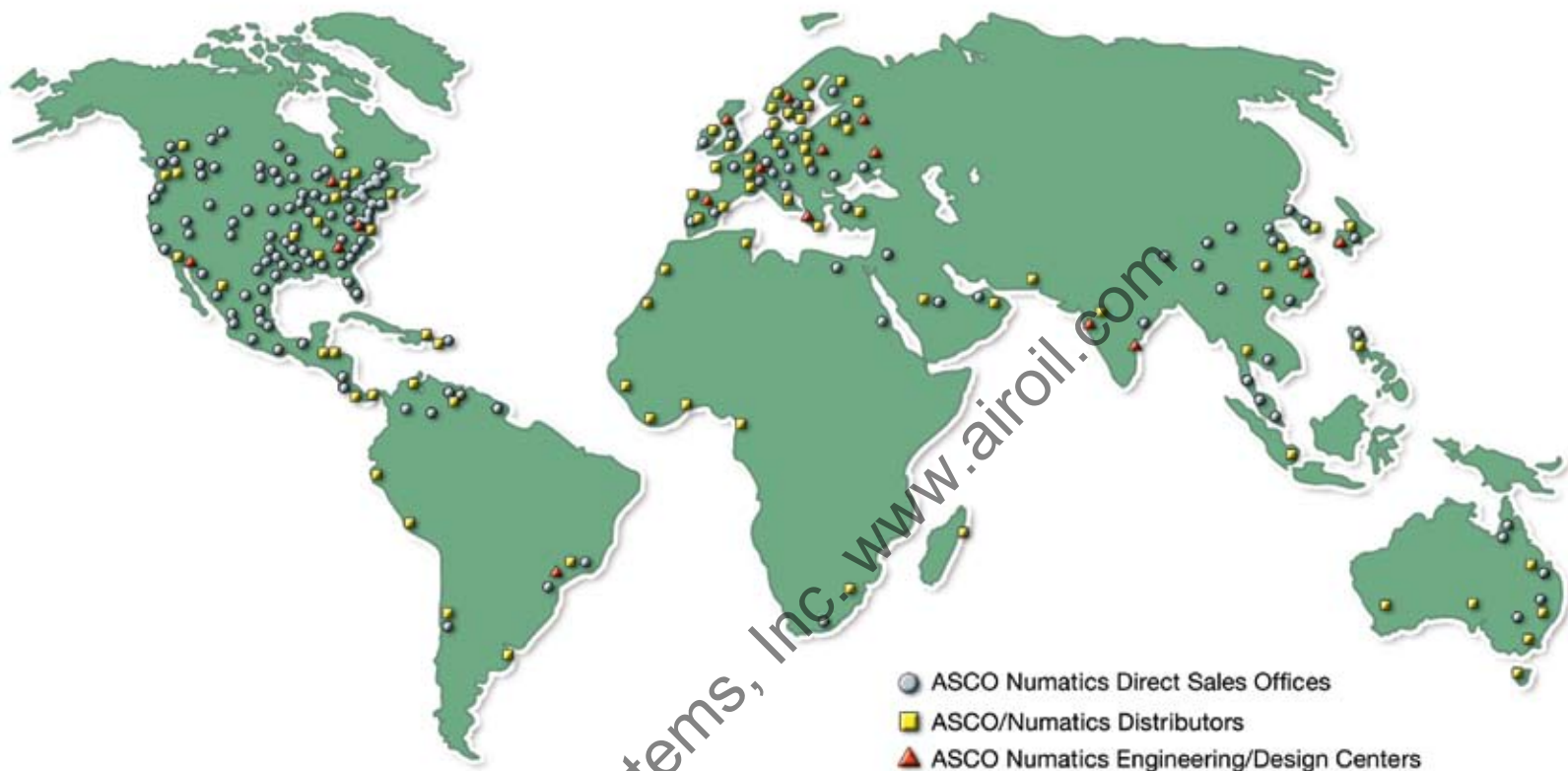

WORLD HEADQUARTERS

USA

Numatics, Incorporated

46280 Dylan Drive
Novi, Michigan 48377

P: 1-888-Numatics
1-888-686-2842

Canada

Numatics, Ltd

P: 519-452-1777

Mexico

Numatics de Mexico S.A. de C.V.

P: 52-222-284-6176

For a comprehensive listing of all Numatics production and distribution facilities worldwide, visit:

www.numatics.com