



numatics®

Air Prep



***Precision  
Instrumentation***

*We're everywhere you need us to be!*



<b>Precision Instrumentation</b> .....	3-18
Features and Benefits .....	3
Precision Regulator .....	4-5
High Flow Precision Regulator .....	6-7
Electropneumatic Transducer .....	8-9
Economy Miniature Electropneumatic Transducer .....	10-11
Miniature Electropneumatic Transducer .....	12-13
Ratio Relay Volume Booster .....	14-15
Instrument Air Regulator .....	16-17
Replacement and Repair Kits .....	18



1. Precision Regulator
  - Standard or High Relief
2. High Flow Precision Regulator
  - 880 Series Regulator
  - 881 Series Precision High Flow Exhaust Relief Regulator
3. Electropneumatic Transducer
  - I/P or E/P Versions
  - Magnet Coil Technology
4. Miniature Electropneumatic Transducer
  - I/P or E/P Versions
  - R84 Series Magnet Coil Technology
  - R85 Series Piezo Electric Technology
5. Ratio Relay Volume Booster
  - Precision Air Pilot Regulation
  - 1:1 or 1:6 Ratios Available
6. Instrument Air Regulator
  - Precision Regulator with Integral 5 Micron Filtration



## Precision Instrumentation

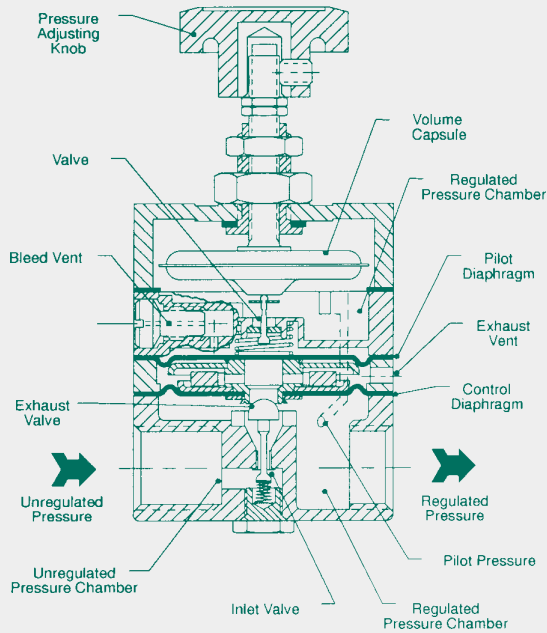
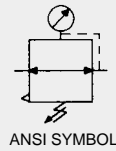

## Precision Regulator

### R80/82 Series

#### Application

The 80 and 82 Series regulators are high-precision, multi-stage pressure regulators. The highest degree of regulation and repeatability are achievable by reacting to downstream pressure fluctuations as small as 0.01 PSIG (.07 kPa). Action occurs as downstream pressure is piloted to the control chamber to act on a finely tuned stainless steel volume capsule. A continuous bleed of less than 0.08 SCFM (.15 m<sup>3</sup>/hr) adjusts the pilot diaphragm causing appropriate movement of the supply valve or relief valve. Relief flows of up to 10 SCFM can be achieved through the large exhaust port located in the control diaphragm. Exhaust is achieved through the exhaust vents located in the side of the body.

#### Recommended Uses

- Air Gauging
- Gas Mixing
- Web Tensioning
- Roll Loading
- Air Hoists

#### Specifications

Flow Capacity: 14 SCFM (25m<sup>3</sup>/hr)

Exhaust Capacity: Model 80 - 2 SCFM (3.4 m<sup>3</sup>/hr)  
Model 82 - 10 SCFM (17.0 m<sup>3</sup>/hr)

Sensitivity: .125 inches (3.2 mm) water

Pilot Bleed Rate: .08 SCFM (.15 m<sup>3</sup>/hr)

Supply Pressure Variation: Less than .005 PSI (.03 kPa)@25 PSI variance

Maximum Supply Pressure: 150 PSIG (1050 kPa)

Weight: 1.4 lbs (.64 kg)

#### Materials of Construction

Body: Die Cast Zinc

Diaphragms: Buna - N

Volume Capsule: Stainless Steel

Knob: Phenolic Plastic

#### How To Order

**R 80 0 - 02 FG**

**Model**  
R = Regulator

**Series**  
80 = Standard  
82 = High relief

**Style**  
0 = all precision regulators

**Threads**  
- = NPTF  
G = G tap (BSPP)

#### Options

D = 2-40 PSIG (80 Series only)

E = 2-60 PSIG (80 Series only)

F = 2-120 PSIG

G = Gauge

T = Tamperproof

#### Port Size

02 = 1/4"

03 = 3/8"

NEED MORE PARTS AND INFORMATION?

- See page 18 for information on ordering replacement parts.



Flow Ratings (based on 100 PSIG inlet)



R820-02F pictured

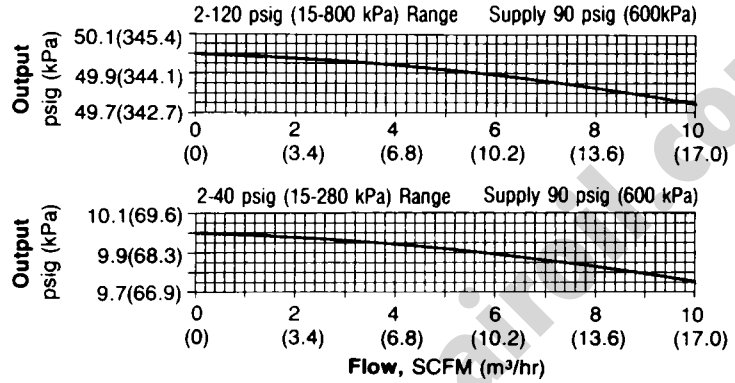

Dimensions

top dimensions = inches  
bottom dimensions (in parenthesis) = millimeters

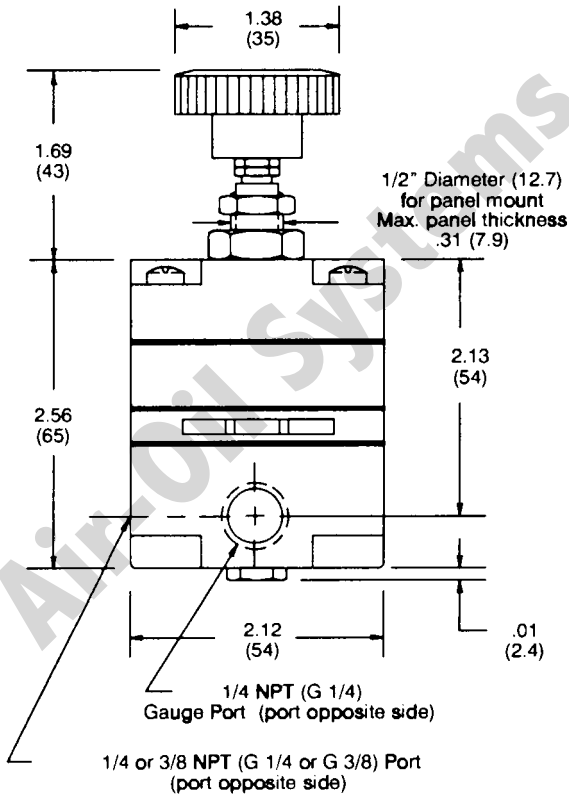

Tamperproof Model

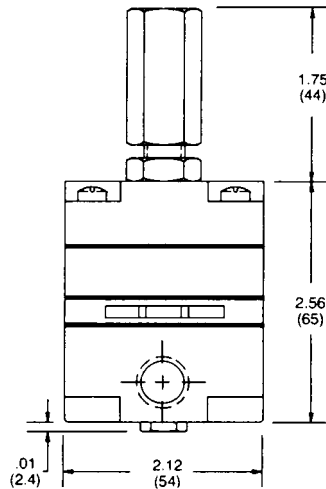



## Precision Instrumentation

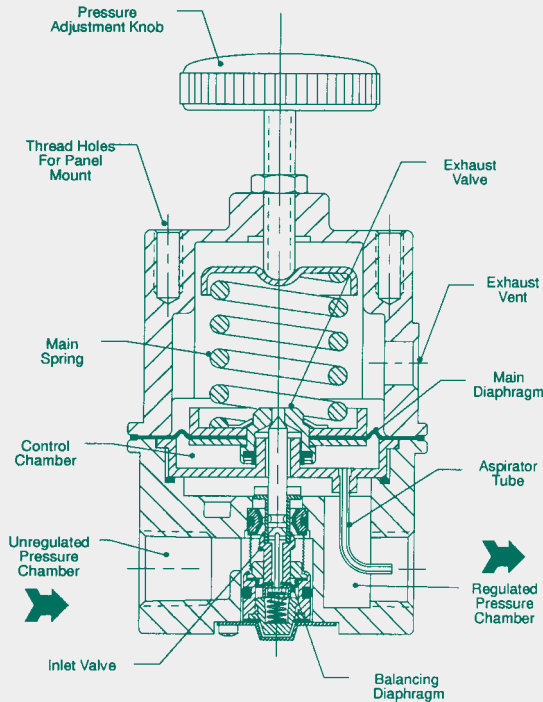
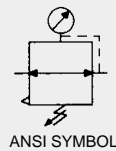

## High Flow Precision Regulator

### R88 Series

#### Application

The 880 Series pressure control regulator is designed for high flow and accurate pressure control utilizing a rolling diaphragm to insure a constant output pressure. The 88 model maintains stability even with wide supply pressure variations.

The 881 Series back pressure regulator is a high flow, highly accurate pneumatic relief valve with an adjustable set point. Its primary function is to provide protection against over pressurization in the downstream portion of a pneumatic system. This precision unit is capable of handling flows up to 50 SCFM. A rolling diaphragm provides the sensitivity that causes the unit to vent to atmosphere in response to the slightest upstream changes.

#### Recommended Uses

- Test Equipment
- Roll Loading
- Web Tensioning
- Actuators
- Gas Mixing
- Test Panels
- Clutch and Brake Controls

#### Specifications

Flow Capacity: see flow characteristics (next page)  
 Exhaust Capacity: 4 SCFM (6.7 m<sup>3</sup>/hr)  
 Sensitivity: .25 inches (6.33 mm) of water  
 Total Air Consumption: 1.0 to 12.5 SCFH (.03 to .37 m<sup>3</sup>/hr), depending on output pressure  
 Supply Pressure Variation: .1 PSI (.7 kPa) @ 100 PSI (700 kPa) change  
 Maximum Supply Pressure: 250 PSIG (1750 kPa)  
 Weight: 1.6 lbs (.74 kg)

#### Materials of Construction

Body: Die Cast Zinc  
 Diaphragms: Buna - N  
 Volume Capsule: Stainless Steel  
 Knob: Phanolic Plastic

### How To Order

**R 88 0 - 02 F G \_ \_**

#### Model

R = Regulator

#### Series

88 = High Flow Precision

#### Style

0 = Standard High Flow Precision Regulator

1 = Back Pressure Precision Regulator

#### Threads

- = NPTF

G = G tap (BSPP)

#### Options

A = 0-2 PSIG (R880 only)

B = 0-15 PSIG

C = 0-30 PSIG

E = 1-60 PSIG

F = 2-150 PSIG

G = Gauge

M = Mounting Bracket

T = Tamperproof

#### Port Size

02 = 1/4"

03 = 3/8"

04 = 1/2"

NEED MORE PARTS AND INFORMATION?

- See page 18 for information on ordering replacement parts.



Flow Ratings (based on 100 PSIG inlet)



R880-02F pictured

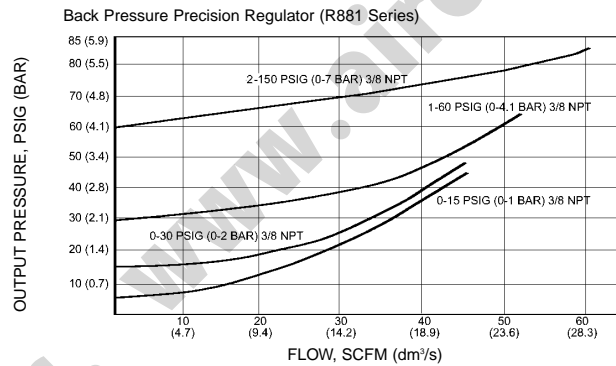
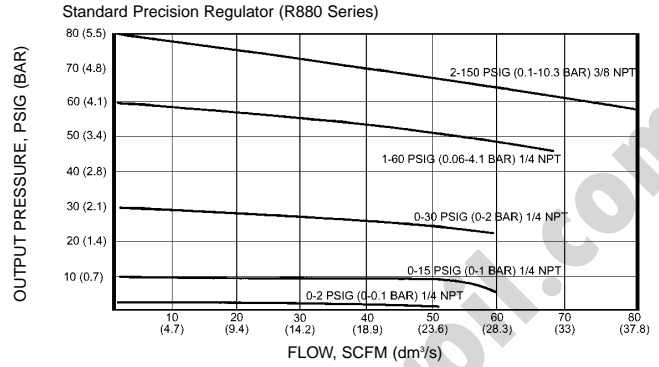

Dimensions

top dimensions = inches  
bottom dimensions (in parenthesis) = millimeters

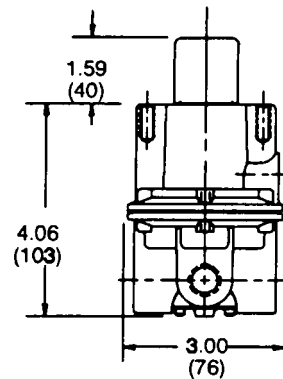
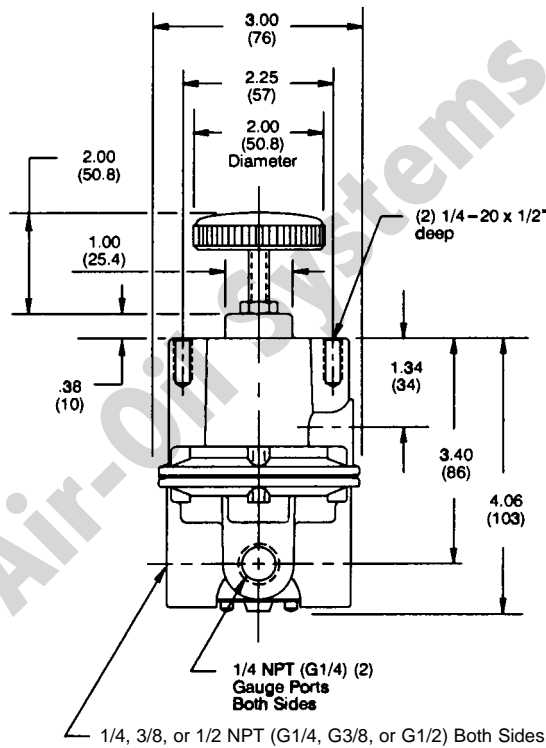

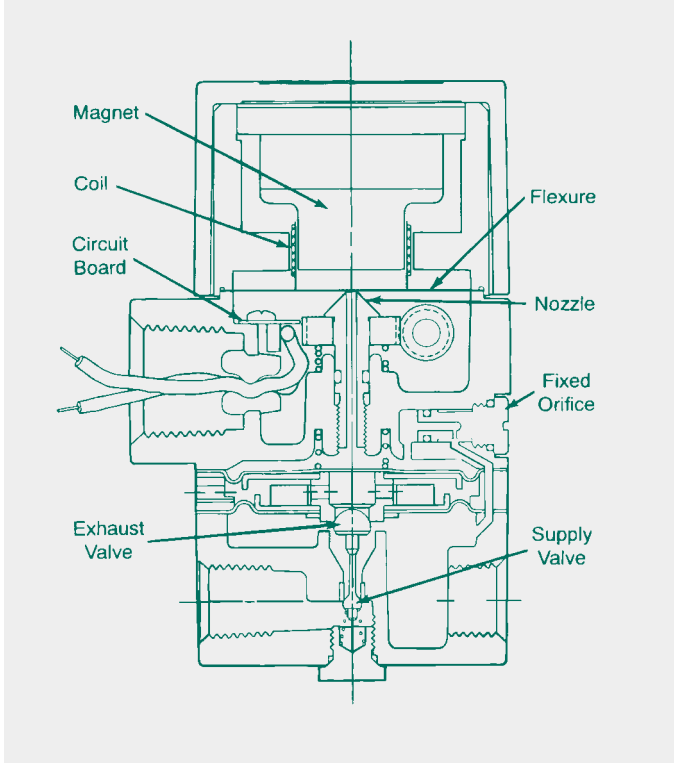

## Electropneumatic Transducer

### I/P, E/P R83 Series

#### Application

The Electropneumatic Transducer (I/P, E/P) converts a current or voltage input signal to a linearly proportional pneumatic output pressure. This versatile instrument is designed for control applications that require a high degree of reliability and repeatability at an economical cost. These units are used for applications that require the operation of valve actuators, pneumatic valve positioners, damper and louver actuators, final control elements, relays, air cylinders, web tensioners, clutches, and brakes.

#### Features

- Integral volume booster
- Compact size
- Low air consumption
- Field reversible
- Flexible zero and span adjustments
- Standard process inputs
- Split ranging
- FM - NEMA 4x

#### Specifications

	Low Output Range (up to 30 PSIG)	High Output Range (up to 120 PSIG)
Min./Max. Supply Pressure:	minimum 3 PSIG (21 kPa) above maximum output maximum 100 PSIG (700 kPa)	minimum 5 PSIG (35 kPa) above maximum output maximum 150 PSIG (1050 kPa)
Supply Pressure Sensitivity:	< +/- .1% of span per PSIG (< +/- .15% of span per 10 kPa)	< +/- .004% of span per 1.0 PSIG (7 kPa)
Terminal Based Linearity:	< +/- .75% of span	< +/- 1.5% of span typ., +/- 2.0% max
Repeatability:	< .5% of span	< .5% of span
Hysteresis:	< 1.0% of span	< .5% of span
Response Time:	dependent on pressure range, typically less than .25 sec. for 3 - 15 PSIG units	dependent on pressure range, typically less than .25 sec. for 3 - 15 PSIG units
Flow Rate:	4.5 SCFM (7.6 m3/hr ANR) at 25 PSIG (175 kPa) supply 12 SCFM (20 m3/hr ANR) at 100 PSIG (700 kPa) supply	20 SCFM (34 m3/hr ANR) at 150 PSIG (1050 kPa) supply
Relief Capacity:	2.0 SCFM (3.4 m3/hr) at 5 PSIG (35 kPa) above set point	2.0 SCFM (3.4 m3/hr) at 5 PSIG (35 kPa)
Maximum Air Consumption:	.03 SCFM (.07 m3/hr) typical	.05 SCFM (.14 m3/hr) typical
Media:	oil free, clean dry air filtered to 0.3 micron	oil free, clean dry air filtered to 0.3 micron
Temp. Range (operating):	-20°F to 140°F (-30°C to 60°C)	-20°F to 140°F (-30°C to 60°C)

NOTE: This unit, as is, is a Class 1, Division 2 hazardous location item (non-incendive). With the proper barrier it is a Class 1,2,3; Division 1; Groups C,D,E,F,G item (applies only to 4-20 Ma I/P).



### How To Order

R 83 1 - 02 F G \_ \_

**Model**  
R = Regulator

**Series**  
83 = I/P, E/P Transducer

**Style**  
1 = 4-20 Ma  
2 = 0-5 VDC  
3 = 0-10 VDC

**Threads**  
- = NPTF  
G = G tap (BSPP)

**Options**  
G = Gauge

**Output Range**  
B = 3-15 PSIG  
(4-20 Ma Input Signal Available)  
C = 3-27 PSIG  
(4-20 Ma Input Signal Available)  
E = 2-60 PSIG  
(4-20 & 0-5 VDC Ma Input)  
F = 3-120 PSIG  
(4-20 & 0-10 VDC Ma Input Signal Available)

**Port Size**  
02 = 1/4"

NEED MORE PARTS AND INFORMATION?

• See page 18 for information on ordering replacement parts.

### Dimensions

top dimensions = inches

bottom dimensions (in parenthesis) = millimeters



R832-02E pictured

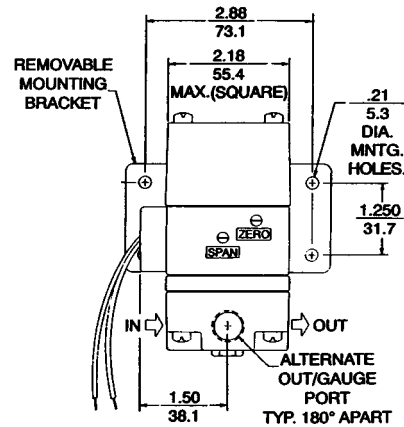
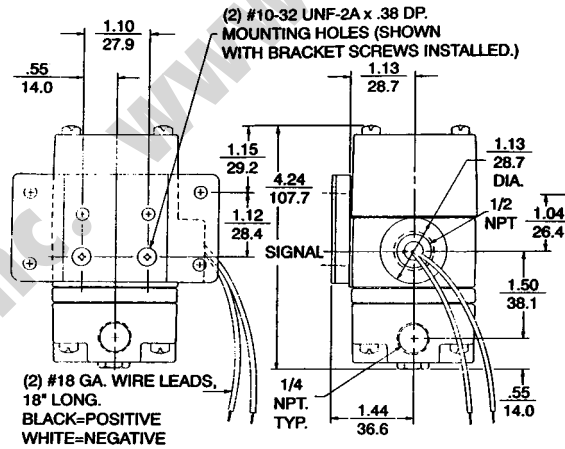

### Electrical Schematic

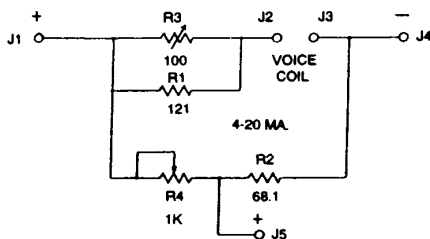

NOTE: FOR 4-20MA AND 10-MA USE J1 AS POSITIVE INPUT.

NOTE: Bracket included with each unit.



## Economy Miniature Electropneumatic Transducer

### R84 Series

#### Application

The R84 Series I/P, E/P transducers are compact electronic pressure regulators that convert an electrical signal (current or voltage) to a proportional pneumatic output. Its compact design and flexible porting make it an ideal choice for space-constrained DIN rail or manifold applications. A NEMA-4X housing with RFI/EMI protection will allow it to be used in demanding industrial environments.

The operating principle of the R84 is based on a rugged, field-tested force-balance design. A coil is suspended in a magnetic field by a flexure. Varying the electrical signal through the coil positions the flexure to a nozzle. This creates a back pressure that acts as a pilot to an integral volume booster. This provides a high flow which increases control speed in critical applications.

#### Features

- Compact size
- NEMA-4X housing
- Low air consumption
- High flow capacity
- Accessible external orifice
- Input and output ports on both front and back
- RFI/EMI protection
- External zero and span adjustments
- Field reversible
- Wall, panel, pipe or DIN rail mounting
- No separate power supply required

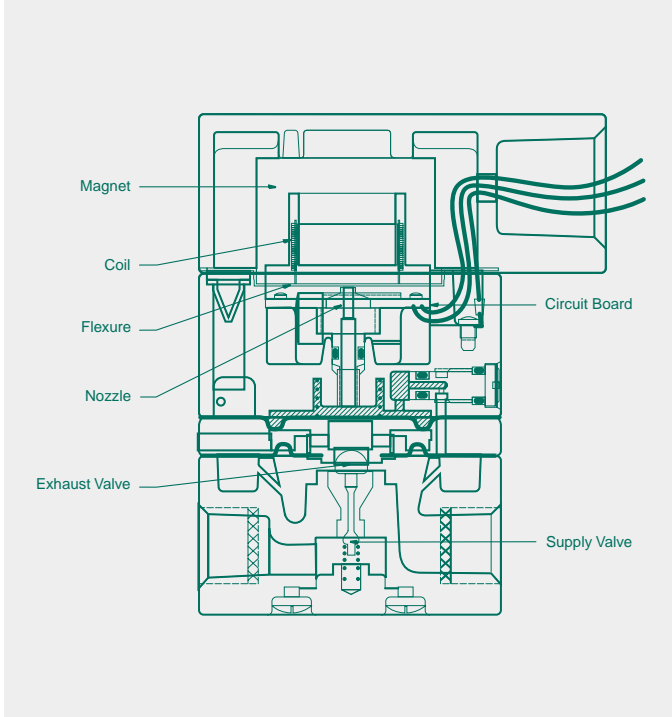

#### Specifications

Linearity (independent): > +/- 0.5% of span

Hysteresis and repeatability: >0.5% of span

Port sizes: Pneumatic = 1/4 NPT  
Electric = 1/2 NPT

Media: Clean, dry, oil-free, air filtered to 0.3 micron

Mounting: Wall, panel (included), 2" pipe (included) or DIN rail (optional)

Materials: Housing: Chromate treated aluminum with baked paint  
Elastomers: Buna-N  
Trim: Stainless Steel, brass, zinc plated steel

Weight: 1.3 lbs (.59 KG)

Inputs: 4-20 mA, 0-5V DC, 0-10 V DC

Outputs: 3-15 psig, 3-27 psig, 2-60 psig, 3-120 psig

Air Consumption: 1.8 SCFH (0.05 m3/hr) at mid Range typical

Supply pressure: Outputs up to 30 psi: 100 psig (7 bar) maximum  
Outputs to 120 psig: 150 psig (10 bar) maximum

Flow Capacity at mid range: 4.5 SCFM (7.6 m3/hr) at 25 psig (1.7 Bar) supply  
12 SCFM (20 m3/hr) at 100 psig (7 Bar) supply

Relief Capacity: 2 SCFM (3.4 m3/hr) at 5 psig (35kPa) above set point

Temperature Range: Operating: -40 to +160 F (-40 to +71 C)  
Storage: -40 to +200 F (-40 to + 93 C)

#### Notes:

Electrical Connections – For both I/P and E/P models, the 1/2" conduit electrical connections are made to the red (+) and black (-) leads. The green lead is used for case ground. For both I/P and E/P models, the 43650 DIN electrical connections are made to terminal 1 (+) and terminal 2 (-). Terminal 3 is not used. Ground is for case ground.





## Miniature Electropneumatic Transducer I/P, E/P R85 Series

### Application

The R85 Series I/P, E/P transducers are a series of compact electronic pressure regulators that convert an electrical signal (current or voltage) to a proportional pneumatic output. Utilizing internal solid-state feedback circuitry, the R85 provides precise, stable pressure outputs to final control elements. Immunity to the effects of vibration or mounting position, high tolerance to impure air, and low air consumption make this unit ideal for use in demanding applications.

The heart of this unique technology is a bimorph piezo actuator that is encapsulated in a protective skin. This protective skin provides defense against the humidity and contaminant often found in process operating environments.

### Features

- Reliable in harsh environments
- Low air consumption - 3 SCFH typical
- High accuracy - +/-0.10% of span
- NEMA-4X (IP65) enclosure
- Vibration/position insensitive
- Compact size
- Wall, panel (included), pipe (included), or din rail mounting
- Supply pressures up to 100 PSIG
- Built-in volume booster - 10 SCFM flow
- Input/output ports on front and back
- Conduit fitting or din connector
- Split range operation
- Field reversible

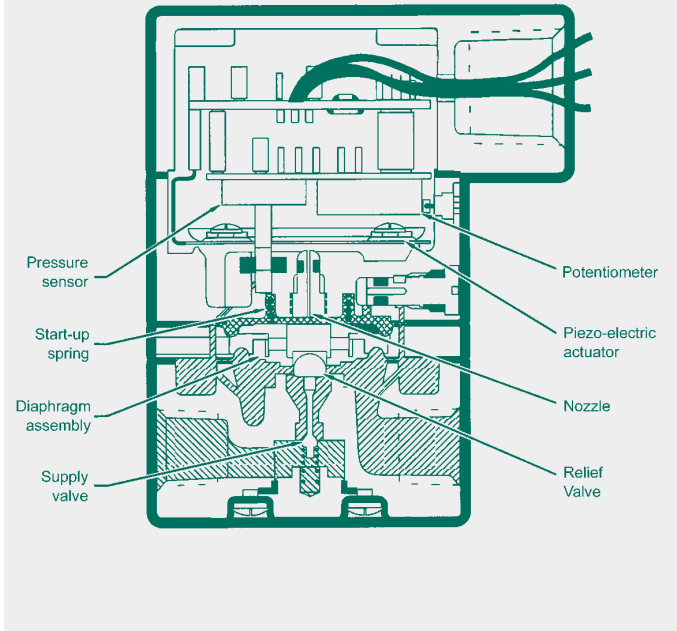

### Specifications

Port sizes:	Pneumatic: 1/4 NPT Electric: 1/2 NPT	
Media:	Clean, dry, oil-free, air filtered to 0.3 micron	
Mounting:	Wall, Panel (included), 2" pipe (included), or DIN rail (optional)	
Materials:	Housing: Chromate treated aluminum with baked paint. NEMA-4X (IP65) Elastomers: Buna-N Trim: Stainless steel, brass, zinc plated steel	
Weight:	13.0 oz (0.4 kg)	
Inputs:	4-20mA	0-10 VDC 0-5 VDC
Outputs:	3-15 PSIG 3-27 PSIG 2-60 PSIG 3-100 PSIG	0.21-1.03 BAR 0.21-1.86 BAR 0.14-4.14 BAR 0.21-6.89 BAR
Air consumption:	3.0 SCFH (0.11 m <sup>3</sup> /hr) at mid-range typical	
Supply pressure:	100 PSIG (7.0 BAR) maximum Note: Supply pressure must be at a minimum of 5 PSIG above maximum output	
Flow capacity at mid-range:	4.5 SCFM (7.6 m <sup>3</sup> /hr) at 25 PSIG (1.7 BAR) supply 12 SCFM (20 m <sup>3</sup> /hr) at 100 PSIG (7 BAR) supply	
Relief Capacity:	2.0 SCFM (3.4 m <sup>3</sup> /hr) at 5 PSIG (35 kPa) above set point	
Temperature limits:	Operating: -40° to +160° F (-40° to +71° C) Storage: -40° to +200° F (-40° to +93° C)	
Loop load, I/P Transducer:	7.5 VDC @ 20mA	
Supply Voltage, E/P Transducer:	7-30 VDC, less than 3mA	
Signal impedance:	7-30 VDC, less than 3mA	



### How To Order

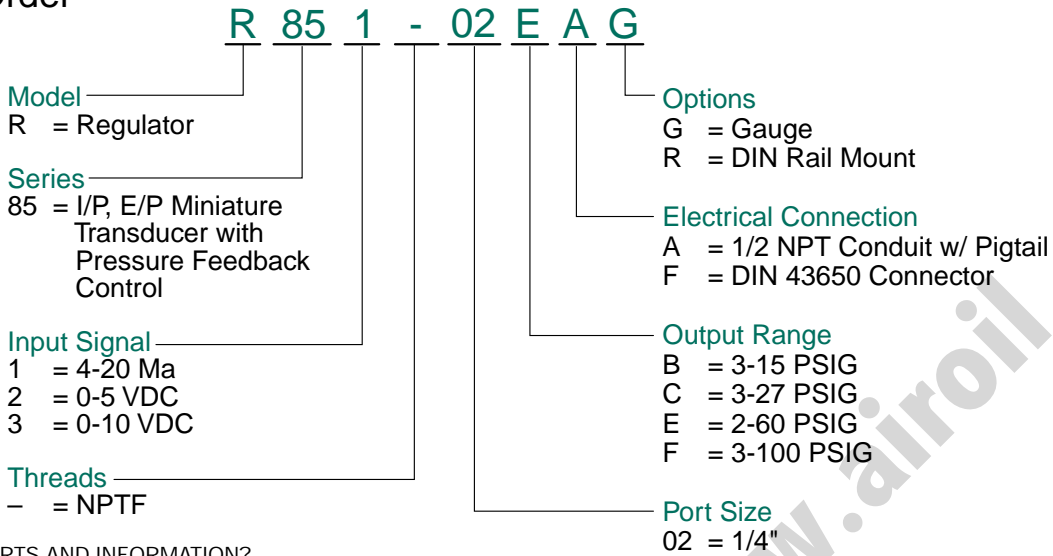

NEED MORE PARTS AND INFORMATION?  
• See page 18 for information on ordering replacement parts.

### Dimensions

top dimensions = inches  
bottom dimensions (in parenthesis) = millimeters



R851-02EA pictured

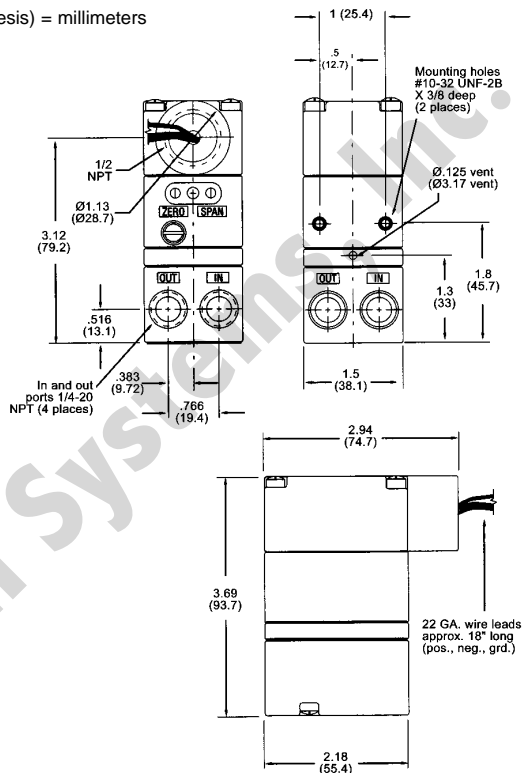

### Panel Mounting (included with standard unit)

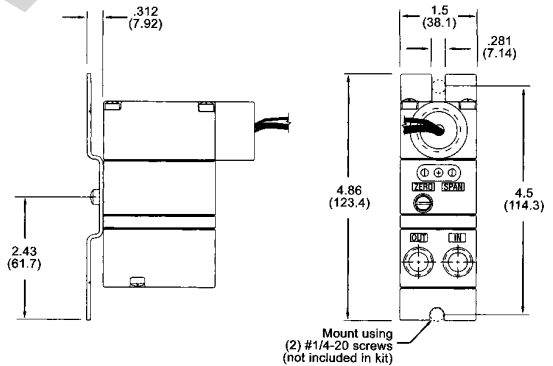

### Pipe Mounting (included with standard unit)

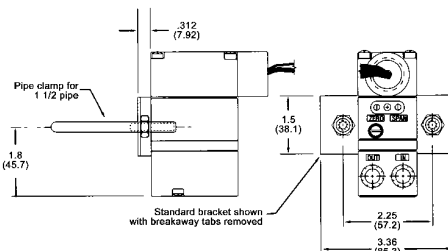

### Flow Ratings

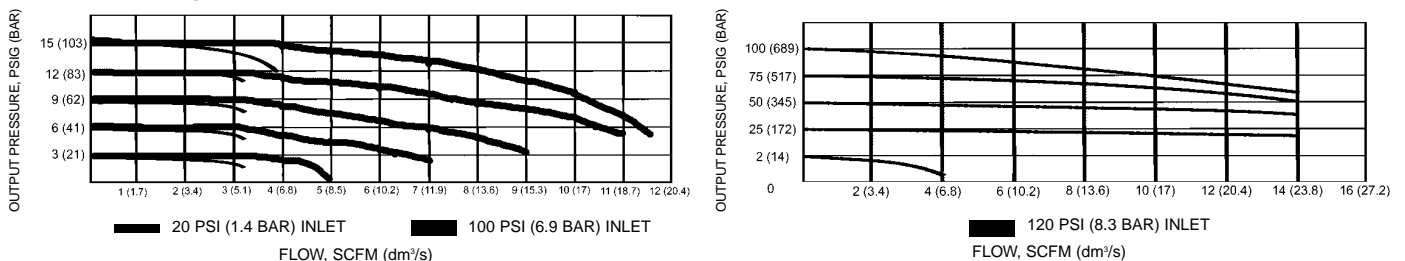

Information subject to change without notice. For ordering information or regarding your local sales office visit [www.numatics.com](http://www.numatics.com).

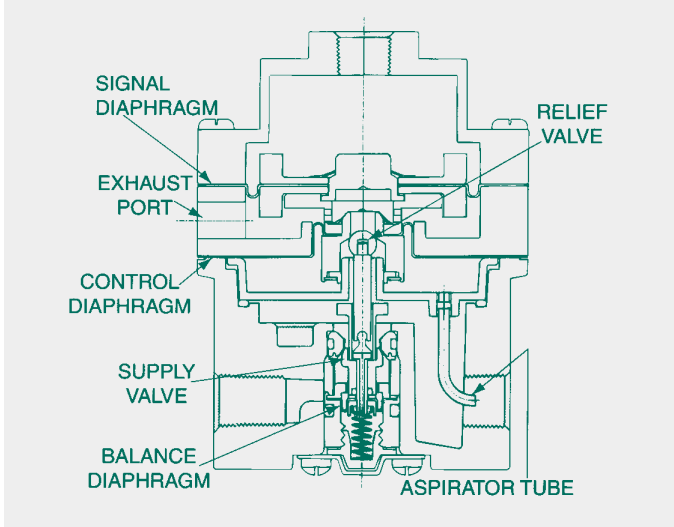

## Ratio Relay Volume Booster

### Applications

The 87 Series Volume Boosters are used extensively for increased flow capacity, pressure amplification, or remote pressure control applications. This includes web tensioning, roll loading, control valve actuators, I/P volume boosting, cylinder actuation, clutch and brake control, and gas flow control.

### Features

- High flow capacity - allows flows up to 50 SCFM
- Amplified output - available in a signal to output pressure ratio of 1:6
- High exhaust capacity - large relief provides 15 SCFM flow capacity
- Stable output - Venturi aspirator maintains output pressure under varying flow conditions
- Balanced supply valve - rolling diaphragm design makes unit immune to supply pressure variation
- Negative bias - 4 PSI negative bias option allows “zero” of I/Ps

### Specifications

Ratio:	1:1	1:6
Flow capacity, SCFM (m3/hr) 100 PSIG (700 kPa) supply, 20 PSIG (140 kPa) output:	50 (76.5)	50 (76.5)
Exhaust capacity, SCFM (m3/hr) Downstream 5 PSIG (35 kPa) above set pressure:	15 (25.5)	7.5 (12.8)
Sensitivity, inches water (cm):	.25 (.64)	1.5 (3.8)
Ratio accuracy (%) of output span with 3-15 PSIG (20-105 kPa) signal:	1.0	2.0
Zero error (%) - % of output span with 3-15 PSIG (21-105 kPa) signal:	2.0	3.0
Effect of supply pressure change of 50 PSIG (350 kPa):	.1 PSI	.6 PSI
Maximum supply pressure, PSIG (kPa):	250 (1750)	250 (1750)
Maximum signal pressure, PSIG (kPa):	150 (1034)	25 (172)
Ambient temperature limits, °F (°C):	-40 to 200 (-40 to 93)	-40 to 200 (-40 to 93)
Weight, lbs (gm):	1.4 (635)	1.4 (635)

### Optional Fixed Negative Bias

The 87 Series Volume Booster is available with an optional 4±1 PSIG (30±7 kPa) less than the signal pressure (Z option). This option allows zero output when utilizing I/P transducers that typically only are capable of providing pressures down to 3 PSI. Note that the negative bias has a tolerance of ±1 PSI. This means that actual bias will range from -3 PSI to -5 PSI. Use the zero adjustment of the I/P to reach desired setting.

### Mounting Bracket

The mounting bracket for the R87 Series Ratio Relay Volume Booster, part number PK88, is included.

### How To Order

R 87 1 - 02 G \_ \_ \_

**Model:**  
R = Regulator

**Series:**  
87 = Volume Booster

**Style:**  
1 = 1:1 Ratio  
6 = 1:6 Ratio

**Threads:**  
- = NPTF  
G = G tap (BSPP)

**Options:**  
B = Mounting Bracket  
G = Gauge  
Z = Negative Bias

**Port Size:**  
02 = 1/4  
03 = 3/8

NEED MORE PARTS AND INFORMATION?

- See page 18 for information on ordering replacement parts.



## Flow Ratings



R871-02 pictured

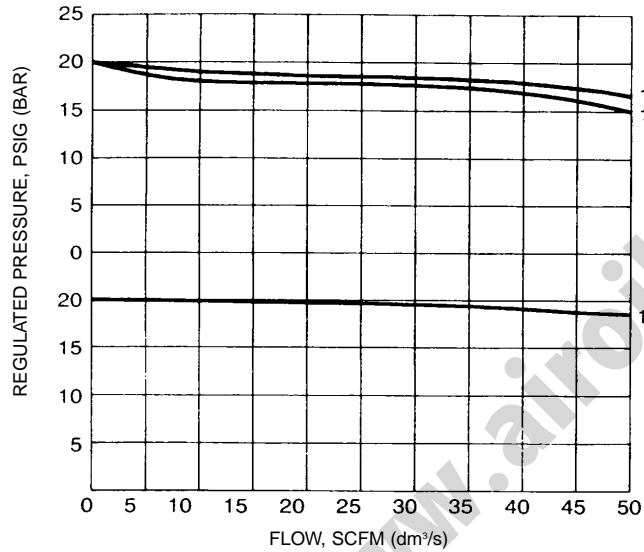

## Dimensions

top dimensions = inches  
bottom dimensions (in parenthesis) = millimeters

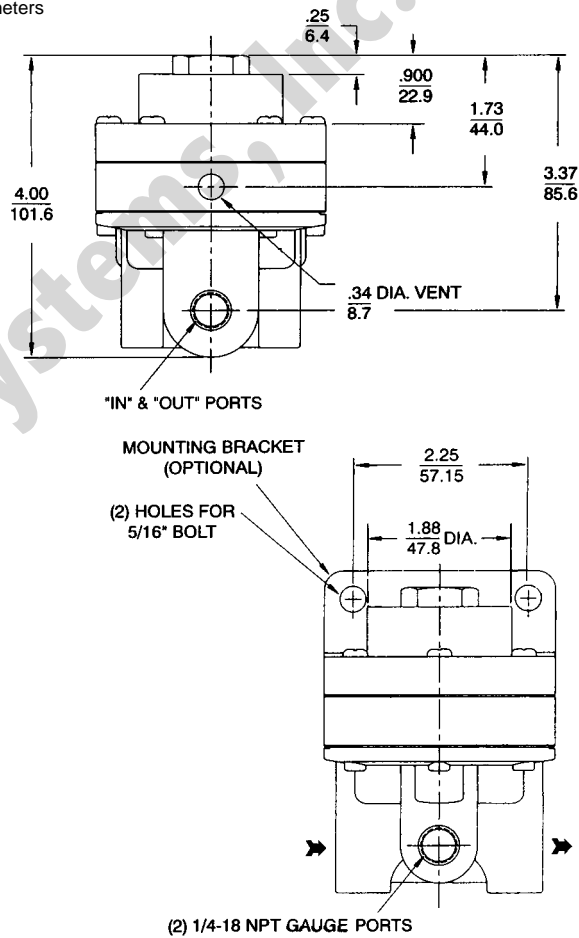

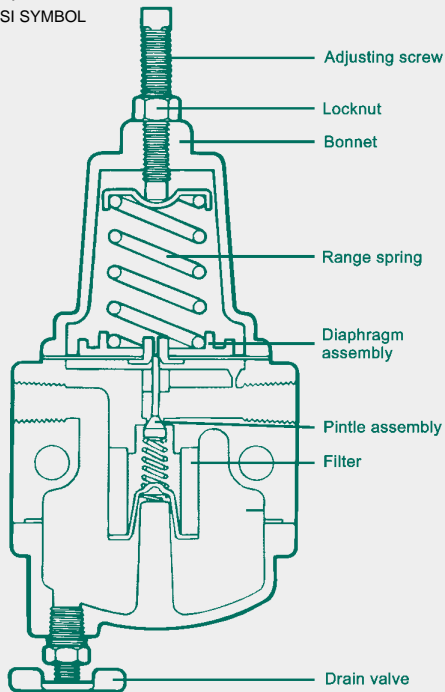
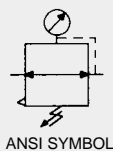

## Instrument Air Regulator

### R89 Series

#### Application

The Instrument Air Regulator is designed to provide clean, accurate air pressure to instruments, valves, and other automatic control equipment. It is used extensively to supply air to pneumatic controllers, transmitters, transducers, valve positioners, air cylinders, and a wide range of pneumatic control systems.

#### Features

- Stable output and repeatability
- Corrosion-resistant construction
- 5 micron depth filter
- Self-relieving
- Low droop at high flow levels
- Tight shut off

#### Materials of Construction

Body: die cast aluminum alloy, irridite, baked epoxy finish  
 Filter: 5 micron phenolic impregnated cellulose  
 Diaphragms: nitrile elastomer and nylon fabric  
 Valve Seat Plug: nitrile elastomer  
 Additional Materials: brass, zinc, plated steel, acetal

#### Mounting Bracket

The mounting bracket for the R89 Series Instrument Air Regulator, part number PK89, is available and sold separately.

#### Specifications

Port Size: 1/4 NPT  
 Standard Output Pressure: 0 - 120 PSIG (0 - 800 kPa)  
 Maximum Supply Pressure: 250 PSIG (1700 kPa)  
 Mounting: pipe or integral mounting  
 Flow Capacity: see flow characteristics (next page)  
 Exhaust Capacity: .1 SCFM (.17 m3/hr) @ 5 PSIG (35 kPa) above set point  
 Sensitivity: 1" (2.5 cm) of water  
 Air Consumption: less than 5 SCFH (.17 m3/hr)  
 Effect of Supply Pressure Variation: less than .2 PSIG (1.4 kPa) @ 25 PSI (170 kPa) change  
 Weight: 1.6 lbs (.74 kg)

#### How To Order

**R 89 0 - 02 F G \_ \_**

**Model:** \_\_\_\_\_  
 R = Regulator

**Series:** \_\_\_\_\_  
 89 = Instrument Air Regulators

**Style:** \_\_\_\_\_  
 0 = All Instrument Air Regulators

**Threads:** \_\_\_\_\_  
 - = NPTF  
 G = G Tap (BSPP)

**Options**

B = 0-10 PSIG  
 C = 0-30 PSIG  
 E = 0-60 PSIG  
 F = 0-150 PSIG  
 G = Gauge  
 K = Knob  
 M = Mounting Bracket  
 N = Non-Relieving  
 P = Panel Mount

**Port Size**  
 02 = 1/4"

NEED MORE PARTS AND INFORMATION?

- See page 18 for information on ordering replacement parts.



Flow Ratings (based on 100 PSIG inlet)



R880-02F pictured

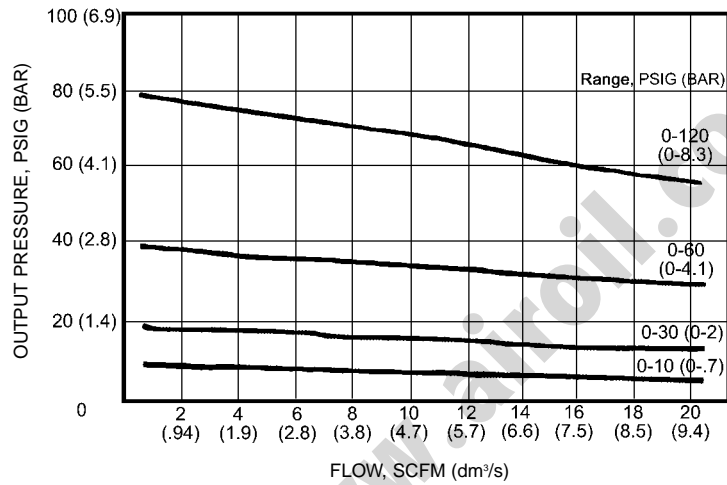

Dimensions

top dimensions = inches  
bottom dimensions (in parenthesis) = millimeters

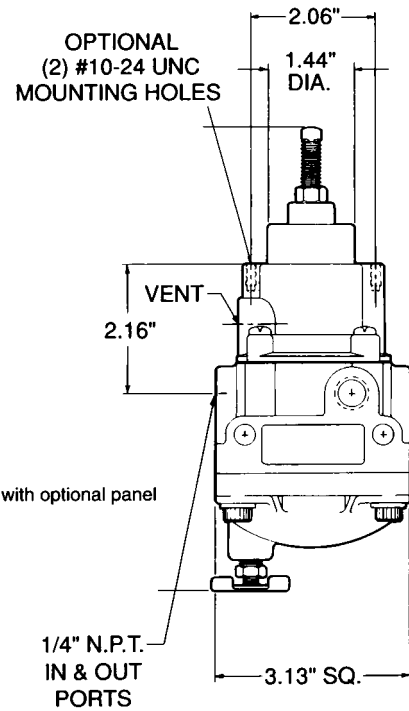
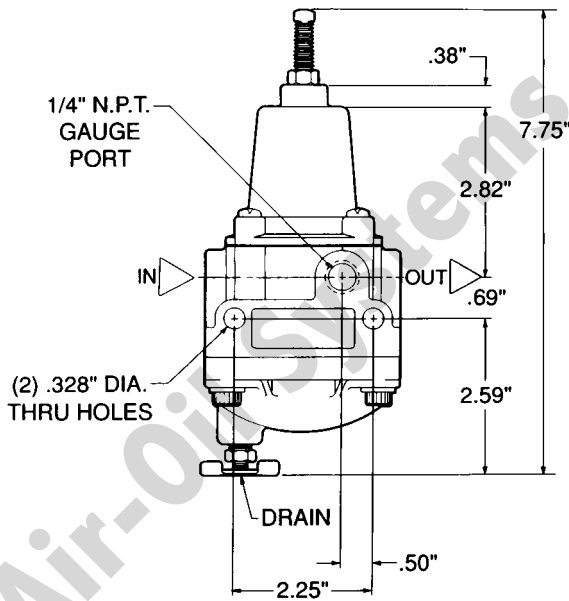

**Note:**  
This view shown with optional panel mount capability.



## Replacement Kits

### Precision Regulators

#### > Precision Regulator Repair Kits

kit #	description
RKR800D	for 2-40 pressure range models
RKR800E	for 2-60 pressure range models
RKR800F	for 2-120 pressure range models
RKR820F	for 2-120 pressure range models

#### > Replacement Adjustment Knob Kits

kit #	description
RP8002	for R800 and R820 models

### Electropneumatic Transducers

#### > Electropneumatic Transducer Repair Kits

kit #	description
RKR831BC	for 3-15 and 3-27 pressure range models
RKR831EF	for 2-60 and 3-120 pressure range models

### High Flow Precision Regulators

#### > High Flow Precision Regulator Repair Kits

kit #	description
RKR880A	for 0-2 pressure range models
RKR880B	for 0-15 pressure range models
RKR880C	for 0-30 pressure range models
RKR880E	for 1-60 pressure range models
RKR880F	for 2-150 pressure range models
RKR881	for back pressure regulator

#### > Replacement Adjustment Knob Kits

kit #	description
RP81	for R880 models

### Mounting Brackets

#### > High Flow Precision Regulator Repair Kits

kit #	description
PK80	80 & 82 Series Bracket
PK88	87 & 82 Series Bracket
PK89	89 Series Bracket

### Instrument Air Regulators

#### > Instrument Air Regulator Repair Kits

kit #	description
RKR89	for all models

# numatics®



## World Class Supplier of Pneumatic Components



### World Headquarters

#### Numatics Incorporated

Phone: 248-887-4111

Fax: 248-887-9190

#### Numatics – Air Preparation

Phone: 810-667-3900

Fax: 810-667-3902

#### Numatics – Valves

Phone: 248-887-4111

Fax: 248-887-9190

#### Numatics – Miniature Valves

Phone: 248-960-1400

Fax: 248-960-2160

#### Numatics – Cylinders

Phone: 615-771-1200

Fax: 615-771-1201

#### Numatics – Rodless Cylinders

Phone: 519-452-1777

Fax: 519-452-3995

#### Numatics – Automation

Phone: 440-934-3200

Fax: 440-934-2288

### CANADA

#### Ontario

Numatics, Ltd.

Phone: 519-452-1777

Fax: 519-452-3995

#### Quebec

Numatics, Ltd.

Phone: 514-332-6444

Fax: 514-332-9273

#### British Columbia

Numatics, Ltd.

Phone: 604-574-0401

Fax: 604-574-3713

### EUROPE

#### Germany – European Headquarters

Numatics GmbH

Phone: 011-49-22 41-31 60-0

Fax: 011-49-22 41-31 60 40

#### Hungary

Numatics Kft.

Phone: 011-36-13 82 21 35

Fax: 011-36-12 04 39 47

### England

Numatics Limited

Phone: 011-44-1525-37 07 35

Fax: 011-44-1525-38 25 67

### France

Numatics s.a.r.l.

Phone: 011-33-1 41 21 48 88

Fax: 011-33-1 41 21 48 89

### Italy

Numatics srl

Phone: 011-39-030-373 19 99

Fax: 011-39-030-373 19 81

### Netherlands

Numatics B.V.

Phone: 011-31-418-65 29 50

Fax: 011-31-418-65 29 43

### Spain

Numatics Spain S.L.

Phone: 011-34-93-221 21 96

Fax: 011-34-93-221 35 14

### AFRICA

#### South Africa

Numatics SA (Pty) Ltd.

Phone: 011-27-11-8 65 44 52

Fax: 011-27-11-8 65 42 90

### LATIN & SOUTH AMERICA

#### Mexico

Numatics de Mexico S.A. de C.V.

Phone: 011-52-222-284 6176

Fax: 011-52-222-284 6179

#### Brazil

Valvair Comercial Ltda.

Phone: 011-55-12-351 2874

Fax: 011-55-12-351 1958

### ASIA & PACIFIC

#### Australia

Numatics Australia Pty. Ltd.

Phone: 011-61-3-95 63 86 00

Fax: 011-61-3-95 63 85 11

#### Taiwan – Asian Headquarters

Numatics Co, Ltd. Asia

Phone: 011-886-2-29 15 16 05

Fax: 011-886-2-29 14 18 97

For a comprehensive listing of all Numatics production and distribution facilities worldwide, visit [www.numatics.com](http://www.numatics.com)