

SmartActuator Series

ICR Basic & ICR Plus

INTEGRATED CONTROL
ROD-STYLE ACTUATOR

● **ENDURANCE TECHNOLOGY**™

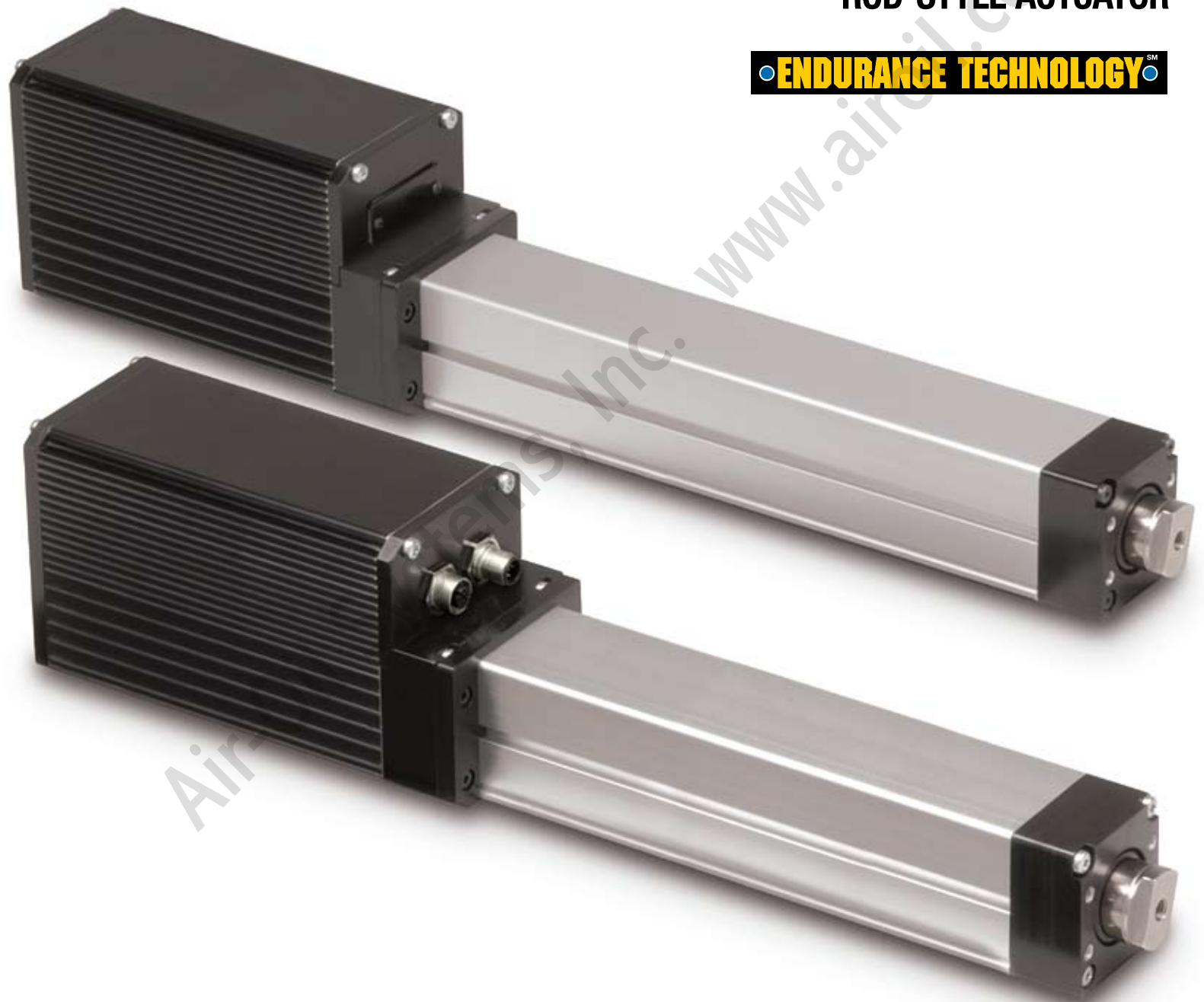

What is a SmartActuator?

The SmartActuator is a controller, drive and motor integrated into one compact, durable, lightweight actuator. Designed for simple extend and retract operation, the ICR Basic can easily be installed and set up by anyone familiar with pneumatic or hydraulic cylinders. For flexibility, the ICR Plus offers indexer programming and network communication capabilities for a wide variety of demanding applications.

Tolomatic has over 50 years of experience manufacturing rodless and rod-style electric and pneumatic actuators. The SmartActuator puts this experience and the intelligence of powerful digital drive technology into one actuator. The result: reliable, affordable power that is remarkably easy-to-use.

ICR Basic & Plus Capabilities

- 100% duty cycle for continuous operation
- 24 Vdc opto-isolated inputs, NPN or PNP
- IP65 option - For protection against water and dust ingress



ICR Basic

The SmartActuator **ICR Basic** features 2-position extend/retract capability, mid-stroke positioning with sensors, and force control.

ICR Basic Capabilities

- 2-position extend / retract
- 2 outputs, 24V line driver; fault, in-position
- 4 inputs, Enable, E-Stop, Fwd., Rev.
- Independent extend/retract speed control
- Mid-stroke positioning with sensors
- Force control/limiting

ICR Plus

The **ICR Plus** has all the ICR Basic capabilities and adds: indexing, network communication, stand-alone operation, stepper and analog position modes.

ICR Plus Capabilities

- Indexer programming
- 2 outputs, opto-isolated sinking/sourcing
- 8 inputs
- Stand-alone operation
- Infinite positioning
- Network communication
 - CANopen
 - DeviceNet
 - RS-232 to CANopen
- Stepper mode (Pulse / direction)
- Analog position mode



Look For:

ENDURANCE TECHNOLOGY™

Endurance Technology features are designed for maximum durability to provide extended service life. This endurance technology symbol indicates our durability design features.

• ICR

SPECIFICATIONS: pg. 12
SIZES



MAXIMUM

STROKE: 24"

THRUST: 400 lbf

SPEED: 25 in/sec

**COMPLETE
INFORMATION:**
www.tolomatic.com

Choose the **Smart**Actuator for these advantages:

vs PNEUMATIC / HYDRAULIC CYLINDERS

- More cost effective to operate
 - Less power consumption
- No costly and messy leaks
- Fewer, cleaner components
 - Eliminates valves, hoses, condensers, mufflers, filters, lubricators, compressors
- Precise control of position, speed, acceleration and force
- Quiet operation
- Accurately positions load at multiple and repeatable locations
- Ability to synchronize motion with other machine operations

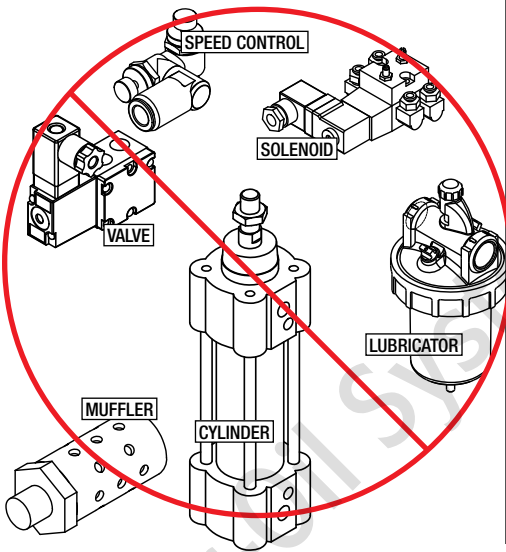

vs INTEGRATED STEPPER ACTUATOR

- True closed loop control ensures position is actually met
- Servo motors supply 100% duty cycle vs. stepper motors which typically supply less than 50% duty cycle
- Expanded speed / torque capability

SPEED vs THRUST
ICR Motor & Integrated Stepper Motor

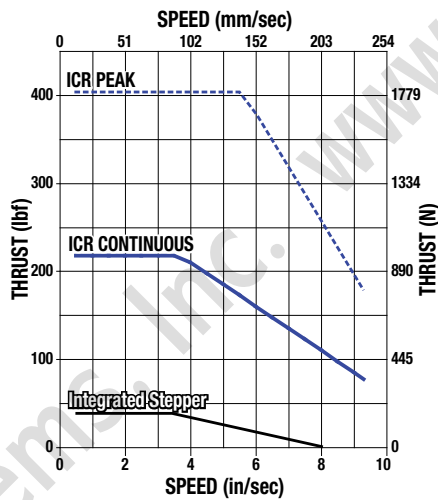

vs TRADITIONAL ELECTRIC SYSTEMS

- Fewer components to purchase and assemble
 - Eliminates separate actuator, motor, drive, cables, coupler and motor mount
- Eliminates need for additional cabinet space: smaller footprint
- Approximately 1/2 the cost of traditional electric actuator systems
- ICR Basic model does not require a computer or software

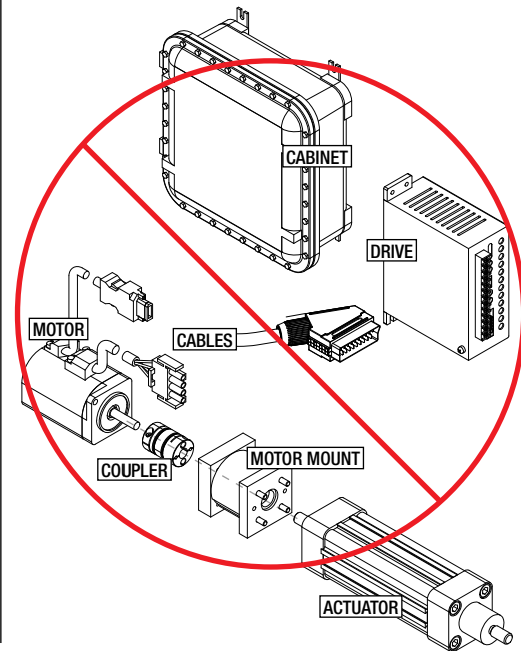

CONTENTS

What is the SmartActuator?.....2	ICR Plus Features10	Selection Guidelines.....19
ICR Basic Introduction4	ICR Specifications & Performance.... 12	Switches20
ICR Basic Features.....6	ICR Dimensions15	Service Parts Ordering22
ICR Plus Introduction.....8	Application Data Worksheet.....18	Ordering.....23

About the ICR Basic

The ICR Basic is an easy-to-use, all-in-one (control, drive, motor, actuator) electric rod-style actuator designed for industrial applications. The ICR Basic is a perfect pneumatic or hydraulic cylinder replacement for low to medium thrust applications. Easy-to-use setup requires no software, tuning or programming.

Capabilities

- 2-position extend / retract
- Independent extend/retract speed control
- Mid-stroke positioning with sensors
- Force control/limiting
- 100% duty cycle for continuous operation
- 4 inputs, Enable, E-Stop, Fwd., Rev.
- 2 outputs, 24V line driver; fault, in-position
- 24 Vdc opto-isolated inputs, NPN or PNP
- IP65 option - For protection against water and dust ingress

ICR Basic Applications

Press Fitting System

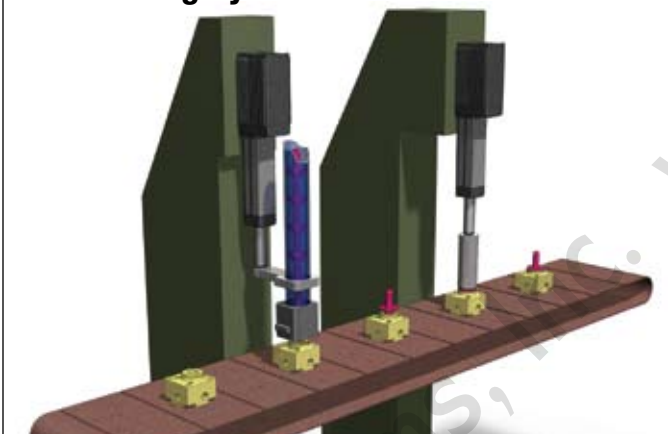

Force control is utilized to limit output force of actuator to press parts together. Similar applications include:

- Parts placement
- Labeling
- Stamping
- Inserting

Parts Transfer

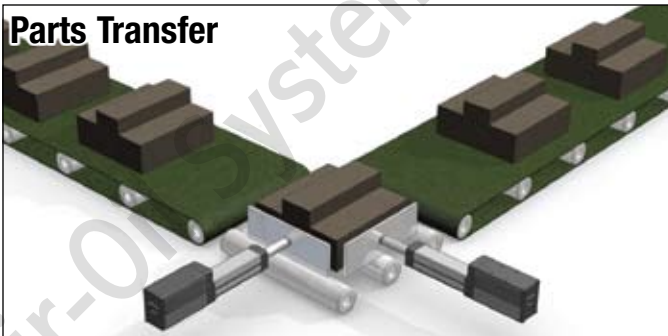

2-position and mid-stroke positioning is used to transfer parts. Examples include:

- Diverting
- Gating
- Sorting
- Rejecting

Alignment of Work



Force control is utilized to align parts, similar applications include:

- Clamping
- Parts verification
- Labeling
- Guiding

ICR Basic Modes of Operation

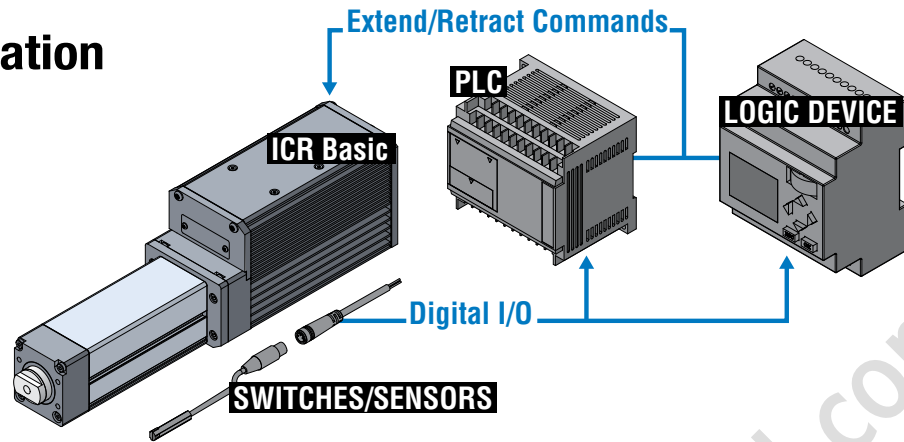

Easy Setup Procedure:

- 1) Mount SmartActuator
- 2) Wire 24 or 48 Vdc power to SmartActuator
- 3) Wire extend, retract, enable, e-stop inputs & in-position/fault output cables to PLC
- 4) Program your PLC (often using same signals as a pneumatic unit)
- 5) Adjust retract speed and extend speed
- 6) Adjust force

Easy Operation

Enable input: Enables or disables the actuator.

Extend / retract input: Extends / retracts the actuator's rod as long as signal is sent or until end of stroke is reached.

E-Stop input: Emergency stop, disables actuator.

Fault output: Sends signal to logic device for a fault condition.

In-position output: Sends signal to logic device indicating actuator is in position and motion is complete.

Speed and force of the ICR Basic are easily adjusted with simple interface controls.

- Speed Control - Independent control of extend and retract speed from 2 to 100% of capable range.
- Force Control - Adjustable from 10 to 100% of maximum force. Once force is reached, the actuator will stop and hold position.

SmartActuator ICR Basic

INTEGRATED CONTROL ROD-STYLE ACTUATOR

ENDURANCE TECHNOLOGYSM

Endurance Technology features are designed for maximum durability to provide extended service life. This endurance technology symbol indicates our durability design features.

ICR-Basic

SPECIFICATIONS: pg. 12
SIZES



MAXIMUM

STROKE: 24"

THRUST: 400 lbf

SPEED: 25 in/sec

ICR BASIC - EXCLUSIVE FEATURE

INTERFACE CONTROLS



- Speed and force controls
- Simple interface that mimics pneumatic valve control
 - Independent extend and retract speed controls
 - Force controls for push and hold or continuous force applications

BALL SCREW TECHNOLOGY

- Oversized ball screw selection for extremely long service life
- Lubricated for life of actuator at the factory with the highest quality synthetic grease



THRUST TUBE

- Hardened nickel plated steel rod ground and polished for greater durability than stainless steel
- Excellent corrosion resistance from many chemicals and resists incidental contact damage

INTERNAL BUMPER

- Bumper protects the screw and nut assembly from damage at the end of stroke

THREADED ROD END

- Nickel plated aluminum for corrosion resistance
- Provides a common interface to multiple rod end options

BEARING

- Unique nose bearing material allows smooth operation and support of the thrust rod

ROD WIPER

- Prevents contaminants from entering the housing for extended life of the actuator

ANTI-ROTATE BEARING

- Engineered resin guide bearings provide anti-rotation of the thrust rod
- Supports the thrust tube and nut assembly through entire stroke length

**5 DAYS
BUILT-TO-ORDER**

ICR BASIC - EXCLUSIVE FEATURE

DIGITAL DRIVE

- Operated via digital I/O to extend/retract
- No software, programming or tuning

DIGITAL ENCODER

- For closed loop control

CONNECTORS

- Standard
- Optional IP65

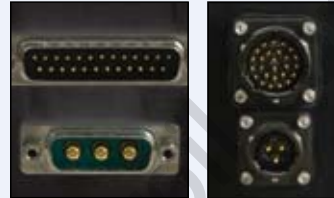

ALUMINUM MOTOR ENCLOSURE

- Fins provide thermal heat dissipation for higher performance

SERVO MOTOR

- 100% duty cycle for demanding applications
- Internal thermal protection

HIGH THRUST BEARING

- Oversized bearing supports the leadscrew and motor
- Large shaft and bearings for longer life and tolerance of radial and axial loads

LIGHTWEIGHT ALUMINUM DESIGN

- Clear anodized extrusion design is optimized for rigidity and strength
- External switch channels and mounting channels along full length on both sides allow easy placement of position indicating switches and tube clamps/mounting plates

FLEXIBLE MOUNTING

- Front face and bottom mounting holes are standard
- Options: front flange, plates, tube clamps, trunnions

OPTIONS

MOUNTING



- Plate (M2 or M3)



- Tube Clamps



- Front Flange

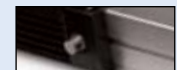

- Trunnion

ROD END



- External Threads



- Clevis



- Eye



- Alignment Coupler

IP65



For protection against water and dust ingress

BRAKE



For vertical applications and energy savings when ICR is not in use

CABLES



- Signal Cable (5m, IP40 or IP65)
- Power Cable (5m, IP40 or IP65)

SWITCHES



Styles include: Reed, Solid State PNP or NPN, all available in normally open or normally closed. RoHs compliant, CE rated

About the ICR Plus

The ICR Plus is an all-in-one (control, drive, motor, actuator) electric rod-style actuator designed for industrial applications, with a powerful, flexible integrated digital drive. The ICR Plus offers programmability, infinite positioning and advanced network communication options.

CAPABILITIES

- Indexer programming
- Stand-alone operation
- Infinite positioning
- Network communication
 - CANopen
 - DeviceNet
 - RS-232 to CANopen
- Stepper mode (Pulse / direction)
- Analog position mode
- 100% duty cycle for continuous operation
- 8 inputs
- 2 outputs, opto-isolated sinking/sourcing
- 24 Vdc opto-isolated I/O that is NPN or PNP
- IP65 option - For protection against water and dust ingress

ICR Plus Applications

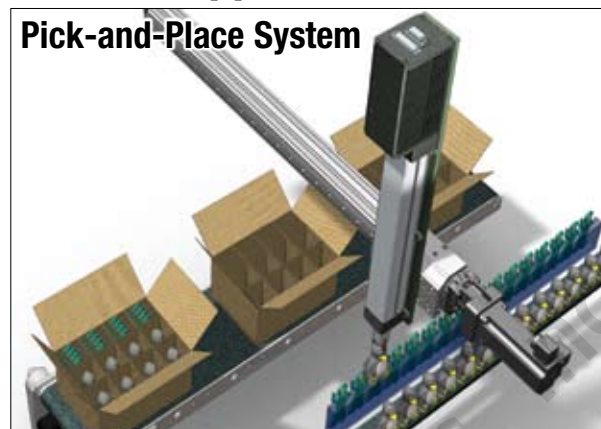

Complex applications utilize flexibility of indexer programming. Examples include:

- Pick and place
- Gantry
- Palletizer
- Cross axis cutter
- Sorter

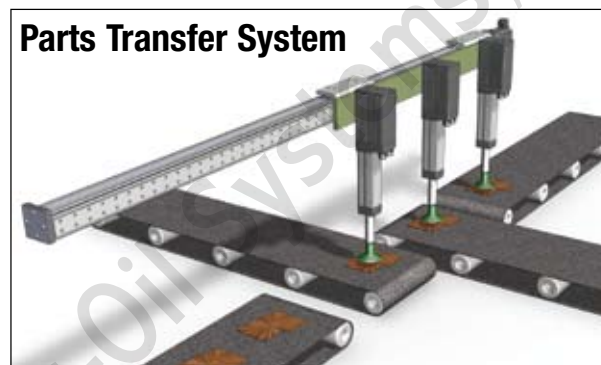

Network communication is utilized to control multiple actuators.

- CANopen - daisy chain up to 127 actuators
- DeviceNet - daisy chain up to 63 actuators
- RS-232 to CANopen - daisy chain up to 127 actuators



Programmable motion profile allows precise control of position velocity and acceleration. Similar applications include:

- Wire winding
- Positioning
- Applying
- Cutting
- Slitting
- Test fixtures
- Inspection

ICR Plus Modes of Operation

(choose one)

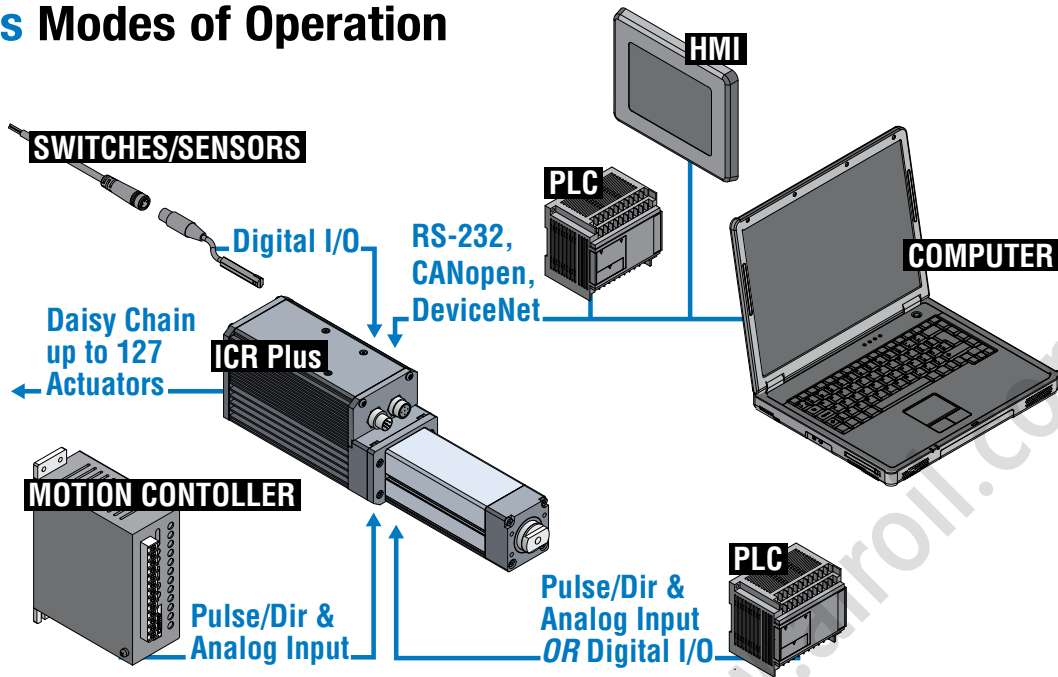

Powerful Software - Intuitive Interface

Input / Output



Control Panel



Indexer Programming

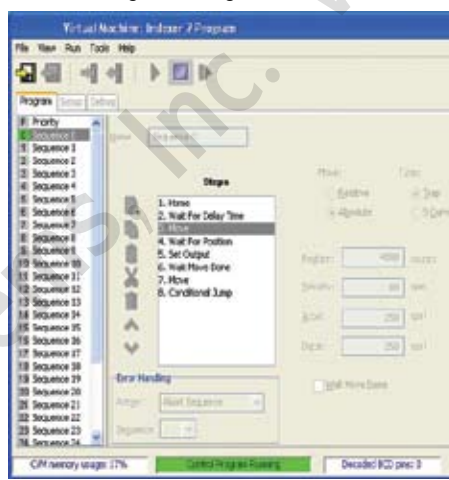

Oscilloscope

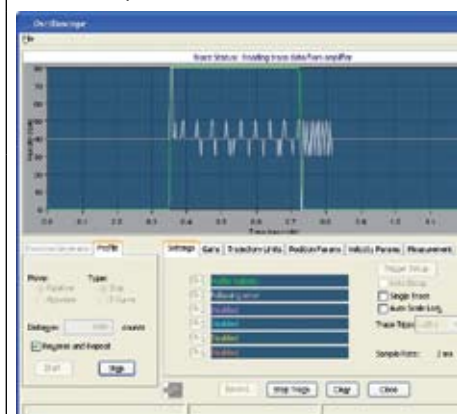

Flexible Operation

Stand-alone mode: PLCs or switches/sensors can send commands to the actuator via digital I/O to invoke indexer program for motion or other logic events.

Communication mode: PLC or PC sends position commands or register changes over RS-232, CANopen or DeviceNet. CANopen (127) and DeviceNet (63) can control multiple actuators simultaneously. The RS-232 port can be used as a gateway to the CANopen bus as well. A Microsoft® COM object library is provided to easily utilize the power of CANopen through Windows® development in VB, C++, .NET, LabView and other programming languages.

Stepper mode: PLC or motion controller sends pulse/direction commands to actuator initiating motion.

Analog position mode: PLC or motion controller sends 0 - 10 VDC analog signal to actuator which equates into an actual position (contact factory for Analog Torque Mode).

SmartActuator ICR Plus

INTEGRATED CONTROL ROD-STYLE ACTUATOR

ENDURANCE TECHNOLOGYSM

Endurance Technology features are designed for maximum durability to provide extended service life. This endurance technology symbol indicates our durability design features.

• ICR-Plus

SPECIFICATIONS: pg. 12
SIZES



MAXIMUM

STROKE: 24"

THRUST: 400 lbf

SPEED: 25 in/sec

ICR PLUS - EXCLUSIVE FEATURE

• COMMUNICATION PORTS



- CANopen - daisy chain up to 127 actuators (CANopen device profile DSP-402)
- DeviceNet - daisy chain up to 63 actuators
- Two ports for easy daisy chain wiring

• BALL SCREW TECHNOLOGY

- Oversized ball screw selection for extremely long service life
- Lubricated for life of actuator at the factory with the highest quality synthetic grease



• THRUST TUBE

- Hardened nickel plated steel rod ground and polished for greater durability than stainless steel
- Excellent corrosion resistance from many chemicals and resists incidental contact damage

• INTERNAL BUMPER

- Bumper protects the screw and nut assembly from damage at the end of stroke

• THREADED ROD END

- Nickel plated aluminum for corrosion resistance
- Provides a common interface to multiple rod end options

• BEARING

- Unique nose bearing material allow smooth operation and support of the thrust rod

• ROD WIPER

- Prevents contaminants from entering the housing for extended life of the actuator

• ANTI-ROTATE BEARING

- Engineered resin guide bearings provide anti-rotation of the thrust rod
- Support the thrust tube and nut assembly through entire stroke length

**5 DAYS
BUILT-TO-ORDER**

ICR PLUS - EXCLUSIVE FEATURE

DIGITAL DRIVE

- Advanced indexer programming environment for maximum flexibility to solve the most demanding applications
- CANopen and DeviceNet communications allow daisy chain of up to 127 units. RS-232 port included
- Full suite of software for setup, diagnostics & debug

DIGITAL ENCODER

- For closed loop control

CONNECTORS

- Standard
- Optional IP65



ALUMINUM MOTOR ENCLOSURE

- Fins provide thermal heat dissipation for higher performance

SERVO MOTOR

- 100% duty cycle for demanding applications
- Internal thermal protection

HIGH THRUST BEARING

- Oversized bearing supports the leadscrew and motor
- Large shaft and bearings for longer life and tolerance of radial and axial loads

LIGHTWEIGHT ALUMINUM DESIGN

- Clear anodized extrusion design is optimized for rigidity and strength
- External switch channels and mounting channels along full length on both sides allow easy placement of position indicating switches and tube clamps/mounting plates

FLEXIBLE MOUNTING

- Front face and bottom mounting holes are standard
- Options: front flange, plates, tube clamps, trunnions

OPTIONS

MOUNTING



• Plate (M2 or M2.5)



• Tube Clamps



• Front Flange



• Trunnion

ROD END



• External Threads



• Clevis



• Eye



• Alignment Coupler

IP65



For protection against water and dust ingress

BRAKE



For vertical applications and energy savings when ICR is not in use

CABLES



- Signal Cable (5m, IP40 or IP65)
- Power Cable (5m, IP40 or IP65)
- Communication cable (1m or 5m)

STARTER KIT

USB to CANopen converter and comm. cables

SWITCHES



Styles include: Reed, Solid State PNP or NPN, all available in normally open or normally closed. RoHs compliant, CE rated

MECHANICAL SPECIFICATIONS

	Unit	BN02	BN05
Screw Type		Ball	Ball
Screw Pitch	tpi	2	5
Screw Diameter	in	0.75	0.63
	mm	19.1	15.9
Screw Lead	in/rev	0.500	0.200
	mm/rev	12.70	5.08
Screw Static Load	lbf	21,000	6,250
	N	93,413	27,801
Screw Dynamic Load	lbf	3,400	825
	N	15,124	3,670
Back Drive Force*	lbf	7.5	12.5
	N	33.4	55.6
Accuracy	in/ft	0.003	0.003
	mm/m	0.02	0.02
Backlash	in	0.015	0.015
	mm	0.38	0.38
Max Thrust	lbf	150	400
	N	667	1779
Max Cont. Thrust	lbf	80	215
	N	356	956
Max Stroke	in	24	24
	mm	609.6	609.6
Base Weight	lb	9.31	7.77
	kg	4.22	3.52
Weight/unit of stroke	lb/in	0.345	0.313
	kg/mm	0.0062	0.0056
Min temp	deg F	50	50
	deg C	10	10
Max temp	deg F	122	122
	deg C	50	50

NOTE: Performance de-rating will be necessary at ambient temperatures greater than 25 deg. C (77 deg F)

IP rating	std	40	40
IP rating	option	65	65
Max Anti-Rotate Tolerance	degrees	±0.25 to ±1.25	

RoHS COMPLIANT RoHs Compliant Components

CE Approval Pending

*In vertical applications an unpowered ICR will require a brake to maintain position if the load on the actuator exceeds this value.



FREE - Windows® compatible software, download at www.tolomatic.com

Or Call 1-800-328-2174 for Excellent Customer Service & Technical Support

SPEED vs THRUST

BN05

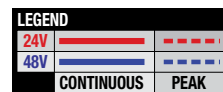
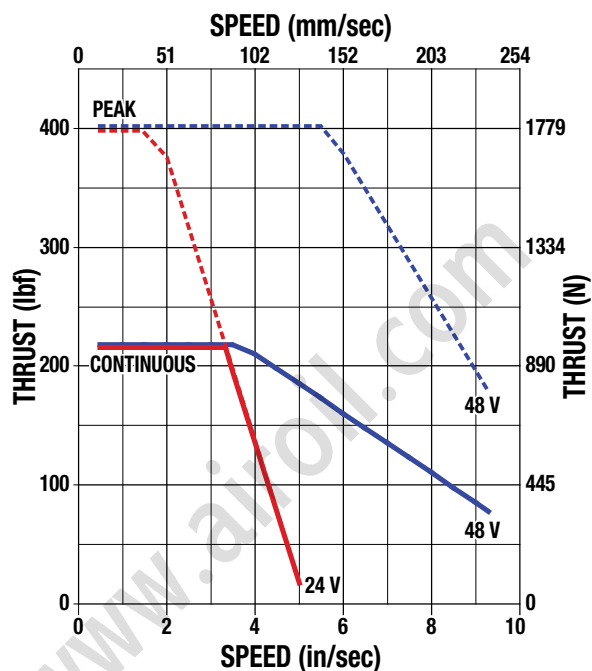

BN02

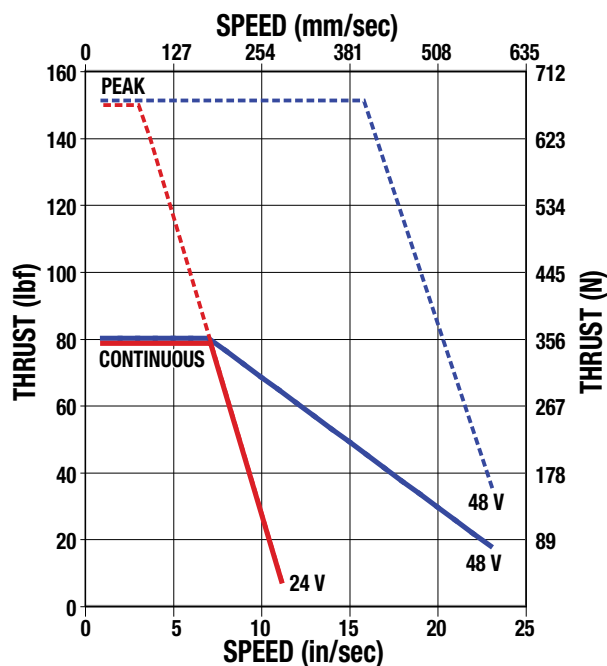

SIDE LOAD CONSIDERATIONS

Rod screw actuators are designed to push guided and supported loads and are not designed for applications that require significant side loading. Contact Tolomatic for details regarding side loading capabilities.

BALL SCREW LIFE

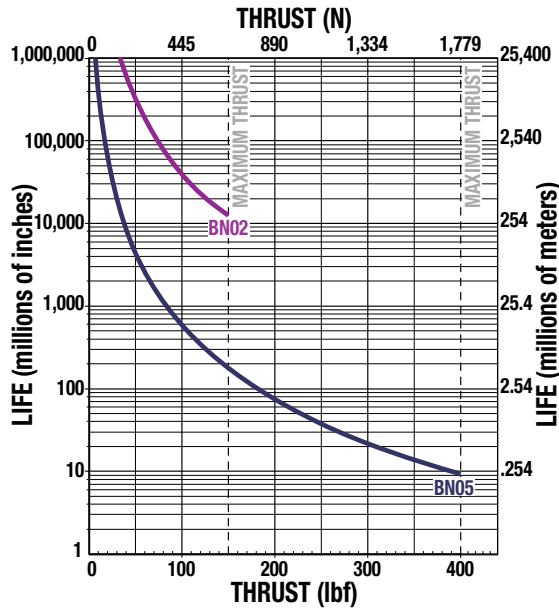

NOTE: The L_{10} expected life of a ball screw linear actuator is expressed as the linear travel distance that 90% of properly maintained ball screws manufactured are expected to meet or exceed. This is not a guarantee and this graph should be used for estimation purposes only.

The underlying formula that defines this value is:

Travel life in millions of inches, where:

$$L_{10} = \left(\frac{C}{F} \right)^3 =$$

C = Dynamic load rating (lbf)
 F = Cubic mean applied load (lbf)

All curves represent properly lubricated and maintained actuators.

ACTUATOR CRITICAL SPEED

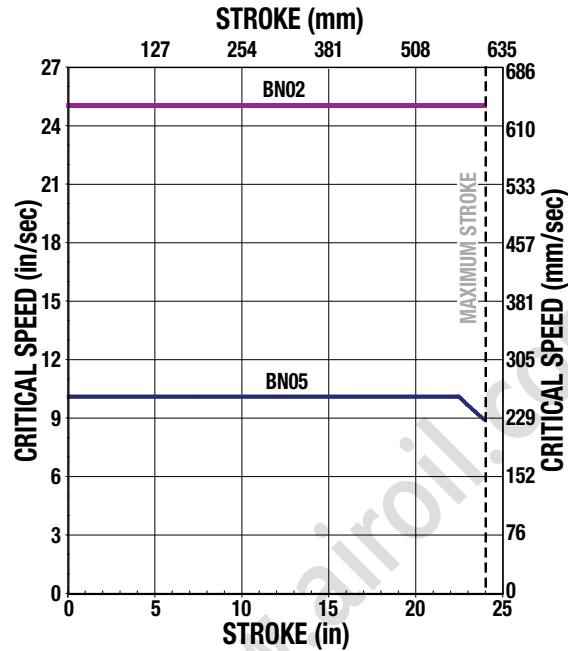

POWER SUPPLY SIZING GUIDELINES

The ICR Basic and Plus actuators are intended to run off an isolated DC power source. The power supply that is required will depend on the application. A 48V supply will allow the actuator to operate at maximum speed. A 24V supply will result in half the rated velocity. Input current will depend on the actuator power needed in the application. If operating more than one actuator on the same power supply add the required power supply rating for each actuator. Call Tolomatic for help in determining power supply for your application.

BN05 (Required Power - Watts)

SPEED (in/sec)	THRUST (lbf)								SPEED (mm/sec)
	50	100	150	200	250	300	350	400	
1	51	66	89	118	155	199	251	309	25
2	64	91	124	164	212	265	326	394	51
3	78	116	160	210	266	329	398	473	76
4	94	142	196	255	320	390	465	546	102
5	111	170	233	300	372	448	528	613	127
6	130	198	270	345	422	503	587	674	152
7	150	228	308	389	472	556	642	730	178
8	171	259	346	433	519	606	693	779	203
9	194	290	384	476	566	654	739	823	229
9.5	206	306	404	498	589	676	761	843	241
	222	445	667	890	1112	1334	1557	1779	
	THRUST (N)								

BN02 (Required Power - Watts)

SPEED (in/sec)	THRUST (lbf)								SPEED (mm/sec)
	20	40	60	80	100	120	140	150	
2	26	47	70	95	123	154	186	204	51
4	36	66	98	132	169	208	249	271	102
6	48	86	127	170	216	263	313	339	152
8	61	109	158	210	264	319	377	406	203
10	77	133	191	251	313	376	441	475	254
12	94	159	226	294	363	434	506	543	305
14	113	187	262	338	415	493	572	612	356
16	134	217	300	383	468	552	638	681	406
18	157	248	339	430	522	613	704	750	457
20	182	281	380	479	577	674	771	820	508
22	209	316	423	528	633	736	839	889	559
24	237	353	467	580	690	799	906	959	610
	89	178	267	356	445	534	623	667	
	THRUST (N)								

Use these tables to help determine the proper power source rating for an application. NOTE: green numbers indicate power supply required in Watts for the given speed and thrust indicated at outside margins.

CALCULATING RMS THRUST AND VELOCITY

Servo motor actuator systems have two speed/thrust curves: one for continuous duty operation and another for intermittent duty. A servo system can be selected according to the total thrust and maximum velocity indicated by the continuous duty curve. However, by calculating the root mean square (RMS) thrust based on the application duty cycle, you may be able to take advantage of the higher peak thrust available in the intermittent duty range. The RMS thrust must fall within the continuous duty region of the motor/drive and the application maximum thrust must fall under the peak thrust of the actuator. Use the following formulae when calculating the RMS thrust and velocity. When selecting an integrated servo actuator system, it is necessary to add a margin of safety to the thrust and velocity required to move the load. The recommended margin for servo motors is 15%.

$$T_{RMS} = \sqrt{\frac{\sum (T_i^2 \times t_i)}{\sum (t_i)}}$$

$$V_{RMS} = \sqrt{\frac{\sum (V_i^2 \times t_i)}{\sum (t_i)}}$$

Where:

T_{RMS} = RMS Thrust

V_{RMS} = RMS Velocity

T_i = Thrust during interval i

V_i = Velocity during interval i

t_i = Time interval i

BRAKE CONSIDERATIONS

An unpowered ICR will require a brake to maintain its position if the force on the actuator exceeds:

BN02 screw - 7.5 lbf (33.4 N); BN05 screw - 12.5 lbf (55.6 N)

A brake can be used with the actuator to keep it from backdriving, typically in vertical applications. A brake may be used for safety reasons or for energy savings allowing the actuator to hold position when unpowered. Add **SAB** to the ordering code for the optional Spring-Applied/Electronically-Released Brake. (not available for service part ordering)

NOTE: The optional Spring-Applied/Electronically-Released Brake requires 24V power. It has a input current rating of 0.414 Amps.

QUESTIONS?

Contact Tolomatic for assistance in choosing the correct ICR actuator and options required for your application.

SYSTEM POWER OVERLOADING CONSIDERATIONS

For applications with large load requirements, care should be taken to prevent the system from generating adverse amounts of power, resulting in overloading and possible failure of the actuator.

Speeds and loads that exceed the amounts indicated in the graph will require the use of a regeneration resistor or some other means to control excess regeneration energy.

Use the Tolomatic Shunt Regulator (part #2180-9811) for preventing over-voltage conditions. Screw terminals are marked with "+" and "-" which should be connected to the power bus.

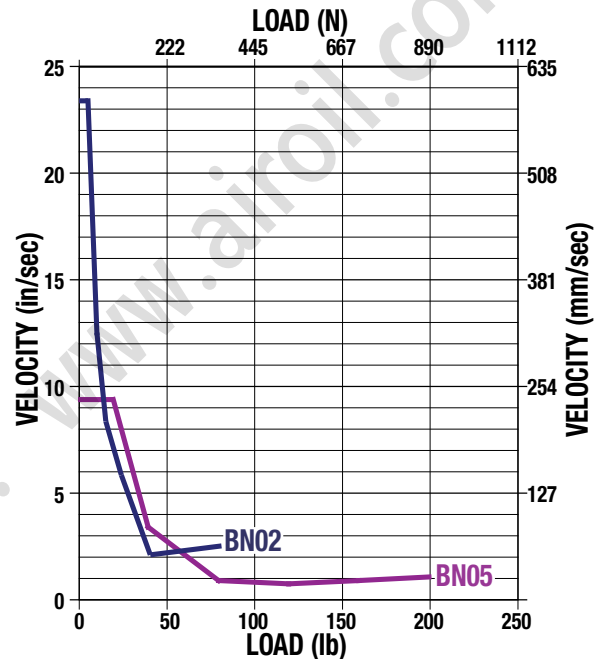



FREE - Windows® compatible software, download at www.tolomatic.com

Or Call 1-800-328-2174 for Excellent Customer Service & Technical Support

ACTUATOR DIMENSIONS

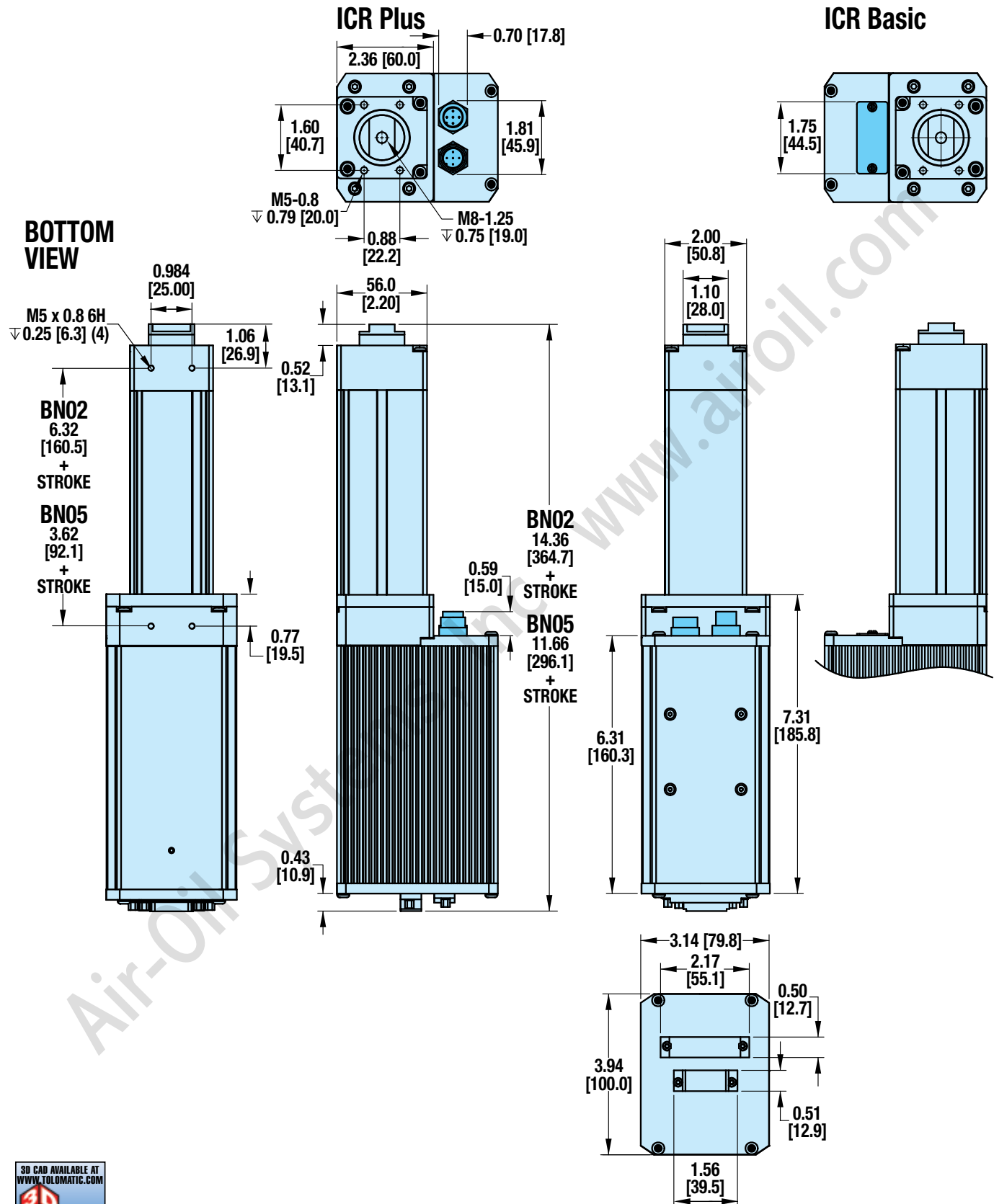

ACTUATOR OPTION DIMENSIONS

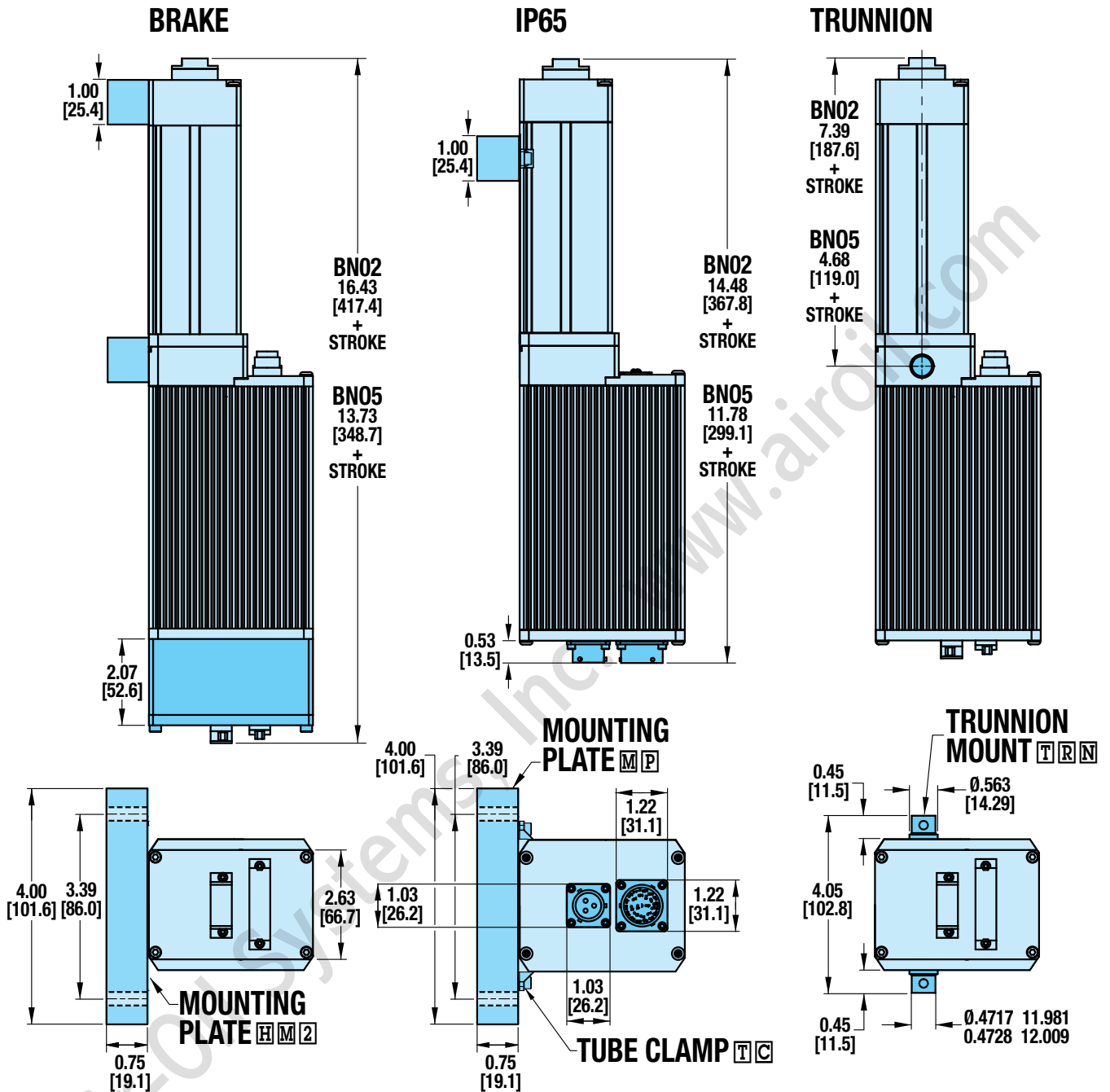

ACTUATOR ROD END OPTION DIMENSIONS

OPTIONAL Spherical Rod Eye End: SRE

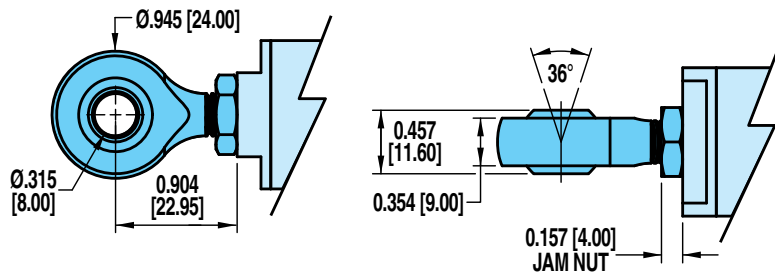

OPTIONAL Alignment Coupler Rod End: ALC

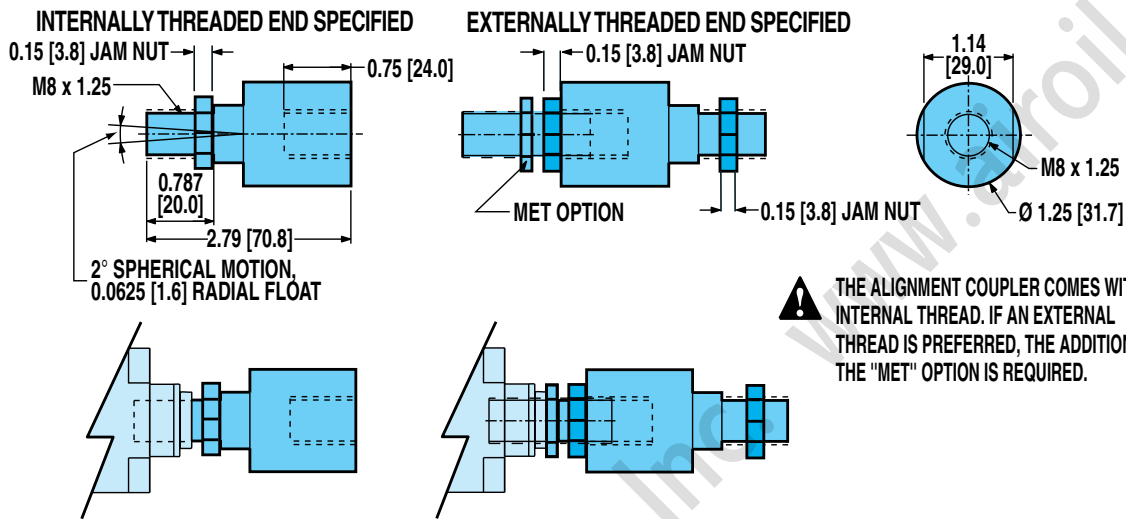

OPTIONAL External Threaded Rod End: MET

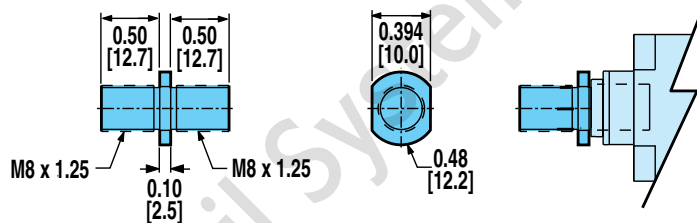

OPTIONAL Clevis Rod End: CLV

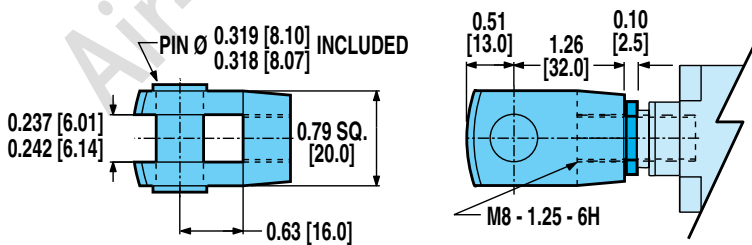

APPLICATION DATA WORKSHEET Fill in known data. Not all information is required for all applications

ORIENTATION

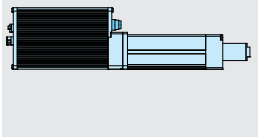
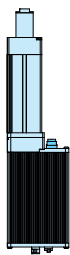
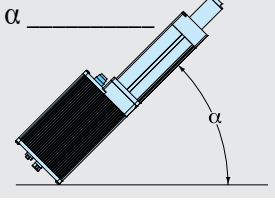
 Horizontal

 Vertical

 Incline °

 Load supported by actuator OR Load supported by other mechanism

SIZING SOFTWARE

FREE - Windows® compatible software, download at www.tolomatic.com

Or Call 1-800-328-2174 for Excellent Customer Service & Technical Support

MOVE PROFILE

EXTEND

Move Distance _____

 inch millimeters

Move Time _____ sec

Max. Speed _____

 in/sec mm/sec

Dwell Time After Move _____ sec

RETRACT

Move Distance _____

 inch millimeters

Move Time _____ sec

Max. Speed _____

 in/sec mm/sec

Dwell Time After Move _____ sec

NO. OF CYCLES

 per minute per hour

HOLD POSITION?

 Required

 Not Required

 After Move

 During Power Loss

POSITION CONTROL

 Manual Jog

 External Control Signal

 via Position Sensors

 Programmable

 PLC via I/O

CONTACT INFORMATION

 Name, Phone, Email _____
 Co. Name, Etc. _____

STROKE LENGTH

 inch (S I) (U.S. Standard)

 millimeters (S M) (Metric)

NOTE: If load or force changes during cycle use the highest numbers for calculations

EXTEND

LOAD

 lb. (U.S. Standard)

 kg. (Metric)

FORCE

 lb. (U.S. Standard)

 kg. (Metric)

RETRACT

LOAD

 lb. (U.S. Standard)

 kg. (Metric)

FORCE

 lb. (U.S. Standard)

 kg. (Metric)

POWER SUPPLY

Amp _____

 24 Vdc

 48 Vdc

PRECISION

Repeatability _____

 inch

 millimeters

OPERATING ENVIRONMENT

 Temperature, Contamination, etc. _____

MOTION PROFILE

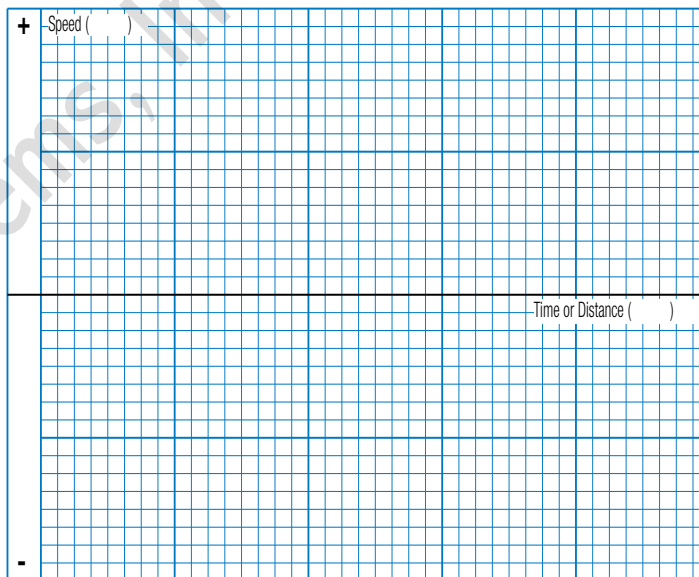

Graph your most demanding cycle, including accel/decel, velocity and dwell times. You may also want to indicate load variations and I/O changes during the cycle. Label axes with proper scale and units.



USE THE TOLOMATIC SIZING AND SELECTION SOFTWARE AVAILABLE ON-LINE AT www.tolomatic.com OR... CALL TOLOMATIC AT 1-800-328-2174. We will provide any assistance needed to determine the proper actuator for the job.

FAX 1-763-478-8080

EMAIL help@tolomatic.com

Selection Guidelines

1 ESTABLISH MOTION PROFILE

Using the application stroke length and maximum velocity (or time to complete the linear motion), establish the motion profile. For a ICR Basic the factory set acceleration and deceleration is BN05: 22.2 in/sec² (564 mm/sec²), BN02: 55.6 in/sec² (1411 mm/sec²). Determine if this acceleration and deceleration allows for desired cycle time. Contact the factory if the acceleration or deceleration needs to be adjusted for an ICR Basic or select the ICR Plus in step 8 for adjustable acceleration and deceleration.

2 COMPARE PEAK THRUST AND SPEED TO PEAK CAPACITIES

Calculate the application required peak thrust and speed and compare to graphs on page 12. (repeated below)

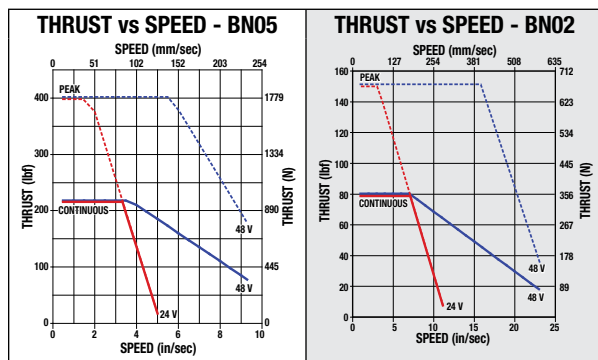

Select the screw choice that achieves the necessary thrust and speed. Note the difference between a 24 or 48 Volt power supply. The 48 Volt will double the speed of 24 Volt.

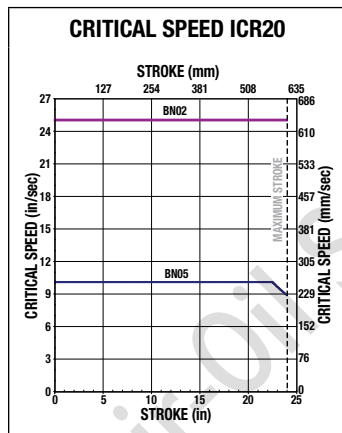

3 COMPARE CONTINUOUS THRUST AND SPEED TO CONTINUOUS CAPACITIES

Calculate the Continuous or RMS thrust and speed required and compare to graphs on page 12. (repeated above)

Select the screw choice that achieves the necessary thrust and speed for continuous operation. See complete instructions on page 14 to help calculate continuous force.

$$T_{RMS} = \sqrt{\frac{\sum (T_i^2 \times t_i)}{\sum (t_i)}} \quad V_{RMS} = \sqrt{\frac{\sum (V_i^2 \times t_i)}{\sum (t_i)}}$$

4 BRAKE CONSIDERATIONS

In vertical applications an unpowered ICR will require a spring applied-electronically released brake to maintain position if the load on the actuator exceeds: **BN02: 7.5 lbf (33.4 N)** **BN05: 12.5 lbf (55.6 N)** Refer to page 14 for more details.

5 POWER LOADING CONSIDERATIONS

Speed and load requirements will determine the power demands of the actuator. To ensure that power overload-ing does not occur, refer to the graph on page 14 to determine if a regeneration resistor or similar device is required.

6 POWER SUPPLY SIZING

Size the appropriate power supply using the table on page 13. Numbers inside of bold box indicate power supply required in Watts. If operating more then one actuator on the same power supply, add the required power supply rating of each actuator.

7 TEMPERATURE

The ICR is intended to operate in an environment with a temperature between 50-122° F, (10-50° C). Performance is de-rated if the temperature is above 77° F (25° C). Contact the factory if the ambient temperature does not fit within this range.

8 SELECT MOUNTING OPTIONS

Examine mounting options dimensional drawings on page 16. Choose to rigidly mount with tapped holes, tube clamps, mounting plates, front flange and alignment coupler. Choose a pivoting mount with trunnion, clevis or eye mount.

NOTE: Temperature at the base of the motor can approach 140°F (60°C)

9 SELECT BASIC OR PLUS MODEL

Determine which model is required for application. An ICR Basic for extend/retract commands with the ability to stop via external I/O. Or the ICR Plus for a fully programmable controller.

10 SELECT OPTIONS

Select options of IP65, cables, and switches.

Call Tolomatic at 1-800-328-2174 for help in determining the best actuator for your application.

SWITCHES SPECIFICATIONS



ICR products offer a wide range of sensing choices. There are 12 switch choices: reed, solid state PNP (sourcing) or solid state NPN (sinking); in normally open or normally closed; with flying leads or quick-disconnect.

Commonly used for end-of-stroke positioning, these switches allow drop-in installation anywhere along the entire actuator length. The one-piece design includes the retained fastening hardware and is designed for the slot on either the left or right side of the actuator. The magnet is a standard feature and is internally located in the anti-rotate bearing. See the dimensional drawings on page 21 for details of switch locations. Switches can be installed in the field at any time.

Switches are used to send digital signals to PLC (programmable logic controller), TTL, CMOS circuit or other controller device. Switches contain reverse polarity protection. Solid state QD cables are shielded; shield should be terminated at flying lead end.

All switches are CE rated and are RoHS compliant. Switches feature bright red or yellow LED signal indicators; solid state switches also have green LED power indicators.



	Order Code	Part Number	Lead	Switching Logic	Power LED	Signal LED	Operating Voltage	**Power Rating (Watts)	Switching Current (mA max.)	Current Consumption	Voltage Drop	Leakage Current	Temp. Range	Shock / Vibration
REED	R Y	8100-9082	5m	SPST Normally Open	—	Red	5 - 240 AC/DC	**10.0	100mA	—	3.0 V max.	—	14 to 158°F [-10 to 70°C]	50 G / 9 G
	R K	8100-9083	QD*											
	N Y	8100-9084	5m	SPST Normally Closed	—	Yellow	5 - 110 AC/DC							
	N K	8100-9085	QD*											
SOLID STATE	T Y	8100-9088	5m	PNP (Sourcing) Normally Open	Green	Yellow	10 - 30 VDC	**3.0	100mA	20 mA @ 24V	2.0 V max.	0.05 mA max.		
	T K	8100-9089	QD*											
	K Y	8100-9090	5m	NPN (Sinking) Normally Open	Green	Red								
	K K	8100-9091	QD*											
	P Y	8100-9092	5m	PNP (Sourcing) Normally Closed	Green	Yellow								
	P K	8100-9093	QD*											
	H Y	8100-9094	5m	NPN (Sinking) Normally Closed	Green	Red								
	H K	8100-9095	QD*											

*QD = Quick-disconnect Enclosure classification IEC 529 IP67 (NEMA 6)

CABLES: Robotic grade, oil resistant polyurethane jacket, PVC insulation

⚠️ **WARNING: Do not exceed power rating (Watt = Voltage x Amperage). Permanent damage to sensor will occur.

SWITCH INSTALLATION AND REPLACEMENT

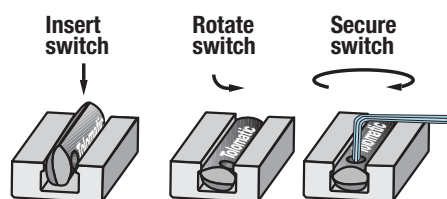

Place switch in side groove on tube at desired location with "Tolomatic" facing outward. While applying light pressure to the switch, rotate the switch halfway into the groove. Maintaining light pressure, rotate the switch in the opposite direction until it is fully inside the groove with "Tolomatic" visible. Re-position the switch to the exact location and lock the switch securely into place by tightening the screw on the switch.

SWITCHES

WIRING DIAGRAMS

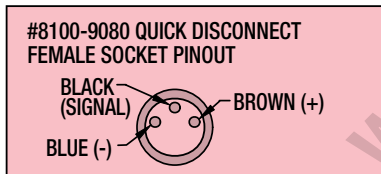
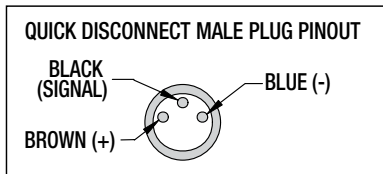
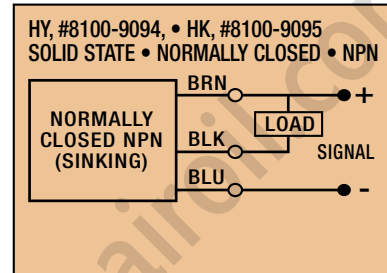
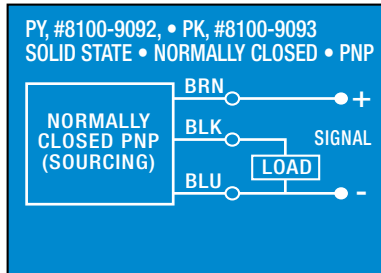
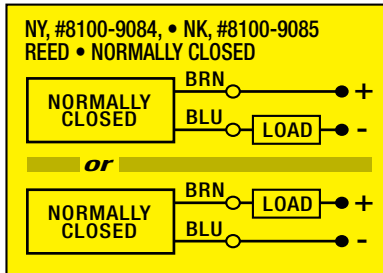
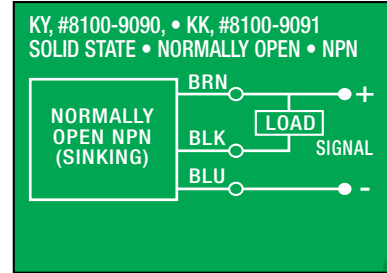
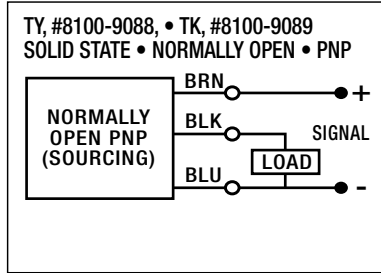
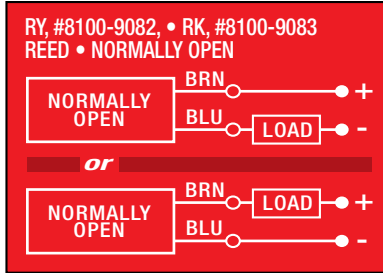

SWITCH DIMENSIONS

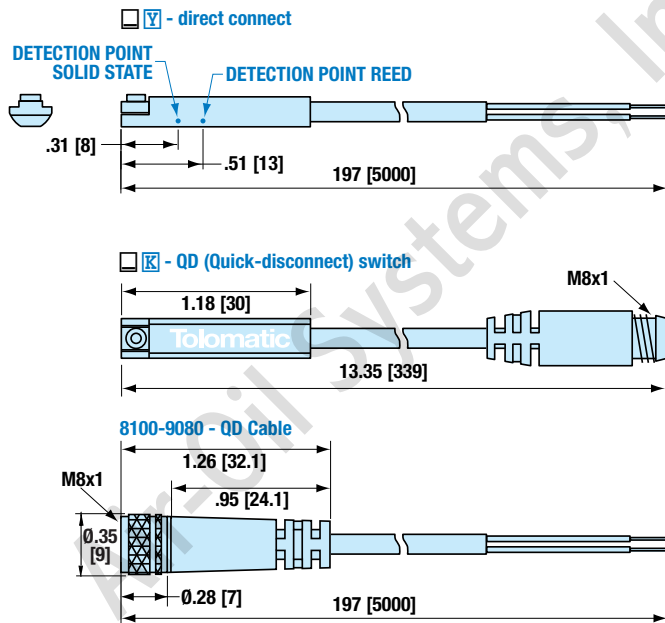

Dimensions in inches [brackets indicate dimensions in millimeters]

MOUNTING DIMENSIONS

ICR20

SWITCHES SIT BELOW TUBE EXTRUSION PROFILE

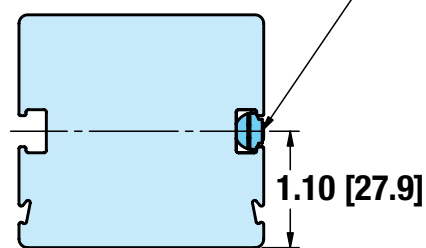

SERVICE PARTS ORDERING

SWITCHES

Switches for ICR actuators include retained mounting hardware and are the same for all actuator sizes and bearing styles

Code	Part Number	Lead	Normally	Sensor Type
R Y	8100-9082	5m (197 in)	Open	Reed
R K	8100-9083*	Quick-disconnect		
N Y	8100-9084	5m (197 in)	Closed	Reed
N K	8100-9085*	Quick-disconnect		
T Y	8100-9088	5m (197 in)	Open	Solid State PNP
T K	8100-9089*	Quick-disconnect		
K Y	8100-9090	5m (197 in)	Open	Solid State NPN
K K	8100-9091*	Quick-disconnect		
P Y	8100-9092	5m (197 in)	Closed	Solid State PNP
P K	8100-9093*	Quick-disconnect		
H Y	8100-9094	5m (197 in)	Closed	Solid State NPN
H K	8100-9095*	Quick-disconnect		

*Also order mating QD cable #8100-9080

	8100-9080	Mating QD (Quick-disconnect) cable 197 in. (5m)
--	-----------	---

OPTIONS

Description	Part Number	Cable Length
CABLES: ICR Basic or ICR Plus		
Signal Cable: IP40	3604-1640	5m
Signal Cable: IP65	3604-1648	5m
Power Cable: IP40	3604-1641	5m
Power Cable: IP65	3604-1649	5m
CABLES: ICR Plus		
1M DeviceNet / CANopen cable	3604-1659	1m
3M DeviceNet / CANopen cable	3604-1660	5m
Adapter cable for USB to CANopen converter	3604-1626	5m

Description	Part Number
MISCELLANEOUS: ICR Basic or ICR Plus	
Shunt Regulator	2180-9811
MISCELLANEOUS: ICR Plus	
Starter Kit (for use with CANopen, USB computer connections and multi-actuator applications) Includes: USB to CAN converter 3604-1627 Adapter cable for USB to CAN converter 3604-1626 Male terminator resistor 3604-1653	2180-9100
Male terminator resistor	3604-1653
Female terminator resistor	3604-1654
USB to CANopen converter	3604-1627
ROD END KITS: ICR Basic or ICR Plus	
Alignment Coupler Kit	2180-9024
Eye Rod End Kit	2180-9058
Clevis Rod End Kit	2112-9020
Threaded Rod End Kit	2112-1058
MOUNTING KITS: ICR Basic or ICR Plus	
Front Flange Mount Kit	2124-9032
Mounting Plate Kit	2180-9002
Tube Clamp Mount Kit (includes 2 Tube Clamps)	8125-9018
Head Mounting Plate Kit (includes 2 mounts)	2108-9026

ORDERING

MODEL SELECTION (MUST BE IN THIS ORDER)

OPTIONS (IN ANY ORDER)

ICR 20P BN05 SM304.8 SV1P CPS CDC5 SAB SRE TC8 TK2

MODEL
ICR ICR Integrated Control Rod-Style Actuator

SIZE, Standard or IP65 Option
20S 20 Series Actuator, Standard
20P 20 Series Actuator, IP65 Option

NUT/SCREW
BN02 Ball Nut, 2 turns per inch
BN05 Ball Nut, 5 turns per inch

STROKE LENGTH
SM _____ Stroke, enter desired stroke length in **millimeters**

MOTOR/DRIVE CONFIGURATION
SV1B Servo Motor, Basic Drive
SV1P Servo Motor, Plus Drive

CABLES
CPS Standard Cables, Power and Signal
CIP IP65 Cables, Power and Signal
CDC1 1m CANopen/DeviceNet Communication Cable
CDC5 5m CANopen/DeviceNet Communication Cable

BRAKE OPTION
SAB Spring-Applied/Electronically-Released Brake
(For holding position when unpowered)

ROD END OPTIONS
MET Male Externally Threaded Rod End
SRE Spherical Eye Rod End
CLV Clevis Rod End
ALC Alignment Coupler

MOUNTING OPTIONS
MP_ Mounting Plates, indicate quantity
HM2 Head Mounting Plates (always 2)
FFG Front Flange Mount
TC_ Tube Clamp, indicate quantity
TRN Trunnion Mount, Rear

SWITCHES
RY_ Reed Switch (Normally Open) with 5-meter lead, & enter quantity desired
RK_ Reed Switch (Normally Open) with 5-meter lead/QD, & quantity
NY_ Reed Switch (Normally Closed) with 5-meter lead, & quantity
NK_ Reed Switch (Normally Closed) with 5-meter lead/QD, & quantity
TY_ Solid State Switch PNP (Normally Open) w/ 5-meter lead, & quantity
TK_ Solid State Switch PNP (Normally Open) w/ 5-meter lead/QD, & quantity
KY_ Solid State Switch NPN (Normally Open) w/ 5-meter lead, & quantity
KK_ Solid State Switch NPN (Normally Open) w/ 5-meter lead/QD, & quantity
PY_ Solid State Switch PNP (Normally Closed) w/ 5-meter lead, & quantity
PK_ Solid State Switch PNP (Normally Closed) w/ 5-meter lead/QD, & quantity
HY_ Solid State Switch NPN (Normally Closed) w/ 5-meter lead, & quantity
HK_ Solid State Switch NPN (Normally Closed) w/ 5-meter lead/QD, & quantity

VISIT www.tolomatic.com/icr
FOR COMPLETE, UP-TO-DATE INFORMATION

! Not all codes listed are compatible with all options.

Call Tolomatic 1-800-328-2174 to determine available options and accessories based on your application requirements.

THE TOLOMATIC DIFFERENCE What you expect from the industry leader:



EXCELLENT CUSTOMER SERVICE & TECHNICAL SUPPORT

Our people make the difference! Expect prompt, courteous replies to all of your application and product questions.



INDUSTRY LEADING DELIVERIES

Standard catalog products are built to order and ready-to-ship in 5 days or less. Modified and custom products ship weeks ahead of the competition.



INNOVATIVE PRODUCTS

From standard catalog products... to modified products... to completely unique custom products, Tolomatic designs and builds the best solutions for your challenging applications.



SIZING & SELECTION SOFTWARE

Windows® compatible, downloadable from our website – FREE – the best tool of its kind on the market! Product selection has never been easier.



3D MODELS & 2D DRAWINGS AVAILABLE ON THE WEB

Easy to access CAD files are available in many popular formats.

ALSO CONSIDER THESE OTHER TOLOMATIC PRODUCTS:

PNEUMATIC PRODUCTS



RODLESS CYLINDERS: *Band Cylinders, Cable Cylinders, MAGNETICALLY COUPLED CYLINDERS/SLIDES; GUIDED ROD CYLINDER SLIDES; ROTARY ACTUATORS*
 "FOLDOUT" BROCHURE #9900-9075 PRODUCTS BROCHURE #9900-4028 www.tolomatic.com/pneumatic

ELECTRIC PRODUCTS



ROD & GUIDED ROD STYLE ACTUATORS, HIGH THRUST ACTUATORS, SCREW & BELT DRIVE RODLESS ACTUATORS, MOTORS, AXIOM DRIVES/CONTROLLERS
 "FOLDOUT" BROCHURE #9900-9074 PRODUCTS BROCHURE #9900-4016 www.tolomatic.com/electric

POWER TRANSMISSION PRODUCTS



GEARBOXES: *Float-A-Shaft®, Slide-Rite®; DISC CONE CLUTCH; CALIPER DISC BRAKE*
 "FOLDOUT" BROCHURE #9900-9076 PRODUCTS BROCHURE #9900-4029 www.tolomatic.com/pt



3800 County Road 116 • Hamel, MN 55340 U.S.A.
 Phone: (763) 478-8000 • Fax: (763) 478-8080

Toll-Free: **1-800-328-2174**

Email: help@tolomatic.com • <http://www.tolomatic.com>

All brand and product names are trademarks or registered trademarks of their respective owners. Information in this document is believed accurate at time of printing. However, Tolomatic assumes no responsibility for its use or for any errors that may appear in this document. Tolomatic reserves the right to change the design or operation of the equipment described herein and any associated motion products without notice. Information in this document is subject to change without notice.

Visit www.tolomatic.com for the most up-to-date technical information

