



Technical Data

***DualVee® Series
MadeWell® Series
MinVee® Series
UtiliTrak® Series
LoPro® Series***

TABLE OF CONTENTS

DualVee® Series	3
Overview	4
System Configuration and Guide Wheel Mounting	5
Life and Wear Resistance	6
Load Capacities, Life Estimate, and Sizing/Selection	7-9
Mounting	10-12
Preloading and Adjustment	13-14
MadeWell® Series	15
Load Capacities, Life Estimate, and Sizing/Selection	16-17
Mounting	18
MinVee® Series	19
Load Capacities and Life Estimate	20-21
Mounting	22
UtiliTrak® Series	23
System Configuration and Guide Wheel Mounting	24
Life and Wear Resistance	26
Load Capacities, Life Estimate, and Sizing/Selection	25-27
Channel Mounting	28
Preloading and Adjustment	29
Maintenance	30
LoPro® Series	31
Drive System Load Capacities	32
Load Capacities, Life Estimate, and Sizing/Selection	33
System Inertia Calculations	34-37
System Mass Calculations	38
Technical Reference	39

Need Help

Application + Design Assistance

925.439.8272

3D Modeling + CAD Drawing

BWC.com

INTRODUCTION

As the inventor of DualVee® Motion Technology, Bishop-Wisecarver offers one of the widest range of guide wheel components in the world. Our offerings are suitable for numerous applications, such as machine designs that require incorporating a component or linear product into the machine structure. Our innovative products, world-class engineering, and custom manufacturing capabilities offer unsurpassed design flexibility. Motion solutions from Bishop-Wisecarver are limited only by your imagination.

This Technical Data Catalog serves as a reference point for you to find the right Bishop-Wisecarver product to suit your needs. Should you have any questions or need additional assistance, our team is available to provide expert guidance on customized solution development and product selection that ensures the right design for your problem, providing documentation, design assumptions, and solution requirements.

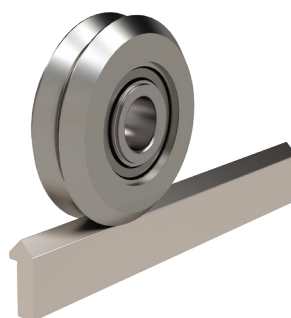

DualVee® Series

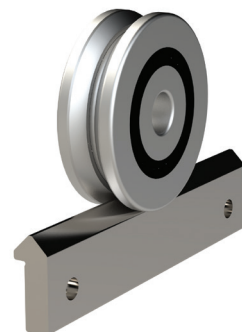

MadeWell® Series

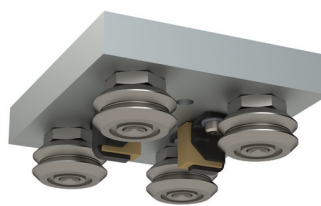

MinVee® Series

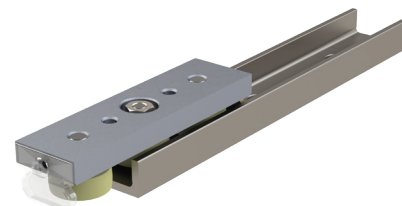

UtiliTrak® Series

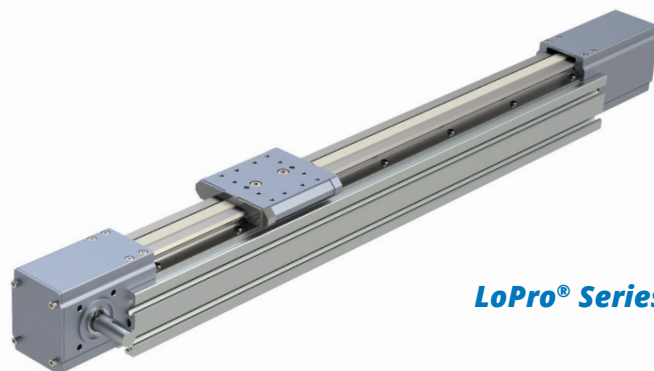

LoPro® Series

DualVee[®] ***Series***

Guide Wheels & Track

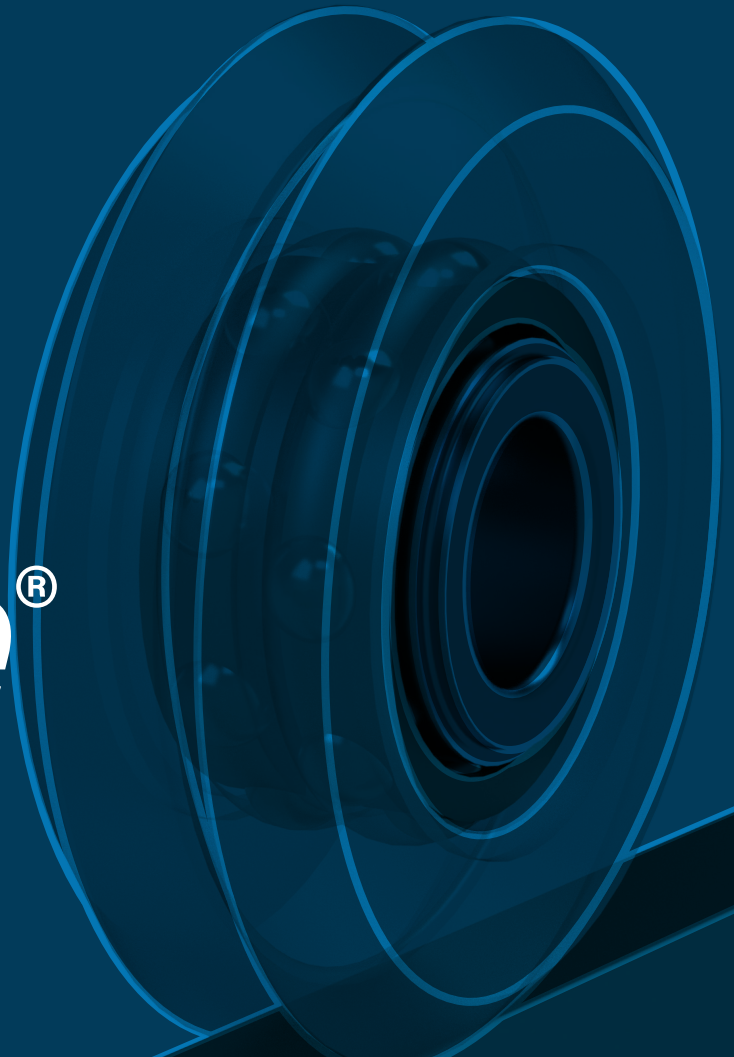

DUALVEE® GUIDE WHEELS (OVERVIEW)

WHEEL TYPE	PART NUMBER SCHEME	APPLICATION CONDITIONS	APPLICATION EXAMPLES	AVAILABLE SIZES	PROTECTION	WHEEL MATERIAL	BALL RETAINER MATERIAL	GREASE	TEMPERATURE RANGE
									(°F)
Original guide wheels carbon	W_	<ul style="list-style-type: none"> General purpose Factory floor conditions 	<ul style="list-style-type: none"> Automation Automotive Woodworking Printing Packaging Paper/textiles 	0, 1	Shield	52100 Steel	Nylon 6,6	Shell Alvania EP2	-31° to +248°
	W_X			0,1, 4XL	Seal	52100 Steel	Nylon 6,6	Shell Alvania EP2	-22° to +212°
				2, 3, 4	Seal/shield				
Original guide wheels stainless	W_S SX	<ul style="list-style-type: none"> Corrosive conditions 	<ul style="list-style-type: none"> Medical Laboratory Food & beverage 	1	Seal	440C Stainless	Nylon 6,6	Shell Alvania EP2	-22° to +212°
				2, 3, 4, 4XL	Seal/shield				
Studded polymer wheels	SWI_P	<ul style="list-style-type: none"> Corrosive conditions Low noise requirements 	<ul style="list-style-type: none"> Electronics Medical Laboratory 	0,1, 2	Shield	Polymer (overmold) 440C Stainless	300 Stainless	Klüberplex BEM034-132	-4° to +248°
Vacuum	W_S S VAC	<ul style="list-style-type: none"> Vacuum environments 	<ul style="list-style-type: none"> Material science 	1, 2	Shield	440C Stainless	304 Stainless	Lubcon Ultratherm 2000	-31° to +482°
Washdown wheels	WDW_S SX	<ul style="list-style-type: none"> Washdown conditions Hygienic environments 	<ul style="list-style-type: none"> Food processing Food packaging 	2, 3	Double seal	440C Stainless	Nylon 6,6	Klubersynth UH1 14-151	-22° to +212°
Food/Pharma wheels	W_S SX H1	<ul style="list-style-type: none"> Washdown conditions Food equipment Pharma equipment 	<ul style="list-style-type: none"> Food processing Food packaging Pharmaceutical 	2, 3	Seal/shield	440C Stainless	Nylon 6,6	Klubersynth UH1 14-151	-22° to +212°
Extreme Temperature Wheels	W_S S 227	<ul style="list-style-type: none"> High temp. conditions Corrosive conditions 	<ul style="list-style-type: none"> Baking Welding Plasma cutters 	0,1, 2, 3, 4	Shield	440C Stainless	304 Stainless	Krytox® GPL227	-22° to +500°
	W_S S 300	<ul style="list-style-type: none"> Low temp. conditions Subzero conditions Corrosive conditions 	<ul style="list-style-type: none"> Aerospace Refrigeration Flash freezing 	0,1, 2, 3, 4	Shield	440C Stainless	304 Stainless	Kluber Isoflex PDL 300A	-94° to +230

Shield material is 300 series stainless steel
 Seal material is NBR
 Seal/shield materials are 300 series stainless steel and NBR combination
 Wheels can be assembled with user specified grease lubricants, call for more information

Shell Alvania is owned by Royal Dutch Shell
 Ultratherm is owned by Lubcon
 Klüberplex, Klubersynth, and Isoflex are owned by Klüber Lubrication
 Krytox® is owned by DuPont

SYSTEM CONFIGURATION AND GUIDE WHEEL MOUNTING

Load Orientation and Eccentric Wheels

In designing a wheel carriage, it is important to use the right combination and orientation of eccentric and concentric guide wheels. Linear guide systems should always have two concentric wheels and all the other guide wheels should be eccentric. The eccentric wheels are adjusted to remove the play between the wheels and track, equally loading all the wheels so that they roll instead of slide or skid on the track. When the wheel carriage is loaded in the radial direction, the pair of concentric wheels should carry the primary load.

It is important to note that the location of the eccentric wheel is dependent upon whether the track guideway is on the outside or inside of the wheel carriage.

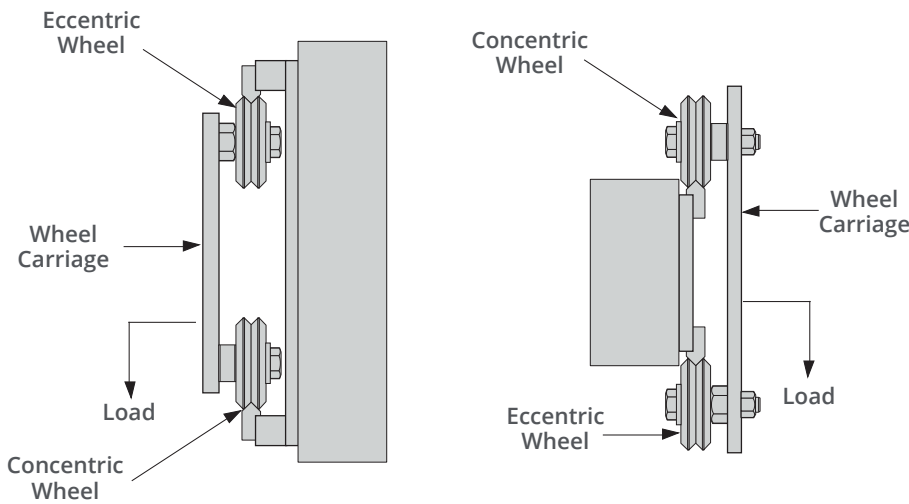

The images to the left show two configurations where the wheels are radially loaded. When wheels are mounted on the inside of the track pair, the concentric wheel should be located in the direction of loading relative to the eccentric wheels (in this case, below). When wheels are mounted outside the track pair, the concentric wheels should be located opposite the direction of loading relative to the eccentric wheels (in this case, above).

Common Carriage Configurations

Below are several wheel carriage configurations. Typical carriage configurations will have 3 or 4 wheels per carriage. Additional guide wheels will increase the load capacity and should be added as additional eccentric versions as shown in the 6 wheel carriage configuration.

3 WHEEL CARRIAGE

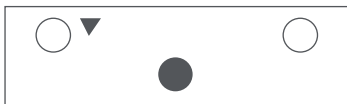

4 WHEEL CARRIAGE

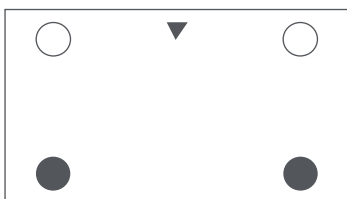

6 WHEEL CARRIAGE

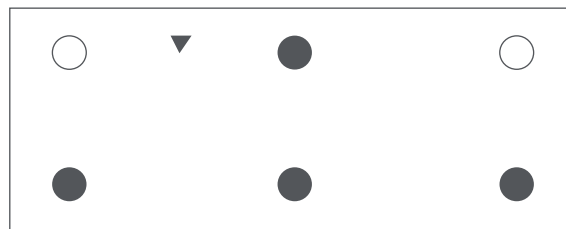

Diagram Symbols:

- = Concentric guide wheel
- = Eccentric guide wheel
- ▼ = Radial loading direction

LIFE AND WEAR RESISTANCE

Harsh/Debris-Laden Environments and Wear Resistance

Since the circumference of the wheel is greater at the major diameter than at the minor diameter, each rotation creates a variation of velocity on the surface of the wheel. This wheel surface velocity variation results in a constant sweeping action. As such, DualVee® guide wheels are successfully employed in a wide variety of harsh environments, including in the presence of metal chips, powders, fibers, slurries, and other environments. The presence of harsh contaminants will reduce the service life of all types of linear guides. However, the DualVee® guide wheel will drastically exceed the service life of competing technologies in harsh, debris-laden environments.

As the hardness of the contaminants approaches the hardness of the track and wheels, the wear rate will increase. For these cases, an adjustment factor should be applied to maximum axial and radial working load capacities to provide a longer operating life.

Lubrication

The other main factor affecting wear resistance is lubrication. Lubrication is the key to maximizing the life of DualVee® linear guide products. Internally, DualVee® guide wheels are lubricated for life with an extreme pressure, corrosion resistant grease. The lubrication of the wheel/track interface is the responsibility of the user.

Lubrication of the guide ways will maximize the load capacity of the system and will significantly increase the service life over a non-lubricated configuration under the same loads. A light machine oil, extreme pressure grease, vegetable oil, or dry lubricant will minimize wear, reduce the friction coefficient and associated stick slip, and inhibit corrosion on the guide ways of a DualVee®-based design. Bishop-Wisecarver uses a lightweight synthetic oil 5W-30 weight for lubrication of guide wheels on vee guide tracks.

Wheel covers or lubricators should be designed in whenever possible. Both will distribute a thin coating of oil lubricant along the contact surface of the DualVee® track. The wheel cover offers added protection by preventing debris from entering the wheel/track contact surface. Lubricated and relatively clean wheel/track contact surfaces will ensure maximum service life in the DualVee® linear guide.

Lubrication will also increase the maximum linear velocity that a DualVee® bearing arrangement can endure. In applications where high speed or high acceleration rates are present, lubrication of the wheel/track interface is highly recommended. Lastly, lubrication will reduce the overall coefficient of friction of the guide, which, depending on the level of preload, can fall anywhere from 0.008 to 0.015. The availability of lubricators and wheel covers gives design engineers an opportunity to design lubrication right into the DualVee® mechanism with little effort. See specifications on wheel covers and lubricators for more details.

Factors Influencing Load/Life

Several factors influence the service life of a linear guide wheel. Through research and development, Bishop-Wisecarver has devised a simple method to estimate the load/life relationship for a specific **DualVee®, MadeWell®, and MinVee®** guide mechanism under defined loading conditions. The methodology accounts for the size of the bearing elements and the load orientation and magnitude. The equation is based upon clean and well lubricated track conditions; for applications where lubrication is prohibitive, a derating factor must be applied. It is important to note that secondary considerations such as maximum velocity, acceleration rates, duty cycle, stroke length, environmental conditions, the presence of shock and vibration, and extreme temperature ranges can all impact service life to varying degrees. As such, the sizing method is considered only as a guideline for the sizing of **DualVee®, MadeWell®, and MinVee®** components.

For maximum loading and heavy continuous use, the "T" series hard edge track should be used. For prototype or light duty intermittent use, the "TS" series unhardened track can be used at a lower cost. Hardened track is surface hardened and polished on the vee surfaces and can be easily drilled or machined in the soft shoulder area.

LOAD CAPACITIES, LIFE ESTIMATE, AND SIZING/SELECTION

Guide Wheel Load Capacity & Mass

WHEEL VARIETY	WHEEL SIZE	RADIAL L _R		AXIAL L _A		MAX LINEAR SPEED (m/s)	MASS (g)		
		N	lbf	N	lbf		ORIGINAL (W...)	BLIND HOLE STUD (SWS.../ SWI...)	THROUGH HOLE STUD (SWA...)
<i>Polymer Overmold</i>	0	28	6	12	3	1	-	6	-
	1	55	12	28	6	1	-	11	-
	2	70	16	42	9	1	-	27	-
<i>Carbon Steel, Stainless Steel, & Food/Pharma</i>	0	650	146	123	28	5.4	5.1	9	9
	1	1220	274	252	57	5.4	11.1	17	20
	2	2650	596	625	141	5.5	39	56	75
	3	5900	1326	1701	382	5.3	130.2	166	193
	4	9700	2181	4001	900	5.3	276	338	403
	4XL	14300	3215	6552	1473	5.1	575	-	-
<i>High Temp. & Low Temp.</i>	0	540	121	102	23	5.4	5.1	9	9
	1	1013	228	209	47	5.4	11.1	17	20
	2	2200	494	519	117	5.5	39	56	75
	3	4897	1101	1412	317	5.3	130.2	166	193
	4	8051	1810	3321	747	5.3	276	338	403
<i>Washdown</i>	2	2420	544	400	90	5.5	37.8	56	75
	3	5200	1169	578	130	5.3	128.3	166	193
<i>Vacuum</i>	1	854	192	178	40	5.4	12	17	20
	2	1855	417	440	99	5.5	39	56	75

Notes:

1. Eccentrically studded or bushed wheels provide adjustability of the wheel to the track. Because of their ability to move and adjust, eccentric wheels are not intended to be the primary carrier of external radial loads. See Wheel Carriage Configurations on page 5.

LOAD CAPACITIES, LIFE ESTIMATE, AND SIZING/SELECTION

Sizing and Selection Steps

The load/life estimation requires a basic understanding of the principles of statics, the ability to work with free body diagrams, and the capacity to resolve externally applied forces on a **DualVee®**, **MadeWell®**, and **MinVee®** based carriage assembly into the radial and axial reaction forces at each guide wheel in the design. The life of a **DualVee®**, **MadeWell®**, and **MinVee®** based carriage assembly will be limited to the life of the most heavily loaded wheel in the design.

Step 1: Calculate the resultant radial and axial loads reflected to each guide wheel element in the linear guide design

All standard considerations involved in statics calculations must be accounted for, including inertial forces, gravitational forces, external forces such as tool pressure, bearing element spacing, and magnitude and direction of the payload. Any external forces that generate a reaction through the wheel/track interface need to be considered. If assistance is required in resolving specific loads into the resultant reaction forces at the guide wheel interface, contact our Applications Engineering staff for support. It is recommended that an application data sheet, which can be found in the DualVee® catalog or on the Bishop-Wisecarver website, be submitted beforehand with as much application information detailed as possible.

Step 2: Calculate the load factor for the most heavily loaded bearings

Bearings should be sized such that $L_f \leq 1$.

The most heavily loaded bearing will have the highest load factor.

Load capacities are available on the previous page.

$$L_f = \frac{F_A}{L_A} + \frac{F_R}{L_R}$$

- WHERE**
- L_f = Load factor
 - F_A = Resultant axial load on the guide wheel
 - L_A = Axial working load capacity of guide wheel
 - F_R = Resultant radial load on the guide wheel
 - L_R = Radial working load capacity of guide wheel

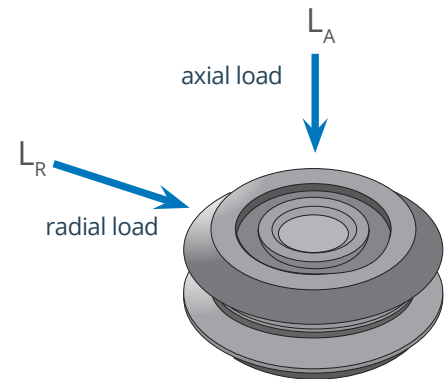

Step 3: Calculate life by applying the load factor to the load/life equation below

Due to varying application load and speed parameters and environmental conditions, the appropriate adjustment factor (A_f) must be applied to the life equation.

The Life Estimate below shares units with the Life Constant.

$$\text{Life Estimate} = \left(\frac{L_c}{(L_f)^3} \right) A_f$$

- WHERE**
- L_f = Load factor
 - L_c = Life constant
 - A_f = Adjustment factor

Life Constant L_c

SYSTEM SIZE	INCHES OF TRAVEL LIFE	KILOMETERS OF TRAVEL LIFE
0	1.65×10^6	41
1	2.19×10^6	55
2	3.47×10^6	88
3	5.18×10^6	131
4	6.84×10^6	173
4XL	8.58×10^6	218

Adjustment Factor A_f

CONDITIONS	A_f
Clean, adequate lubrication, low duty, low shock, low vibration	1.0 - 0.7
Moderate contamination, medium duty, medium shock, low to medium vibration	0.7 - 0.4
Heavy contamination, limited lubrication, high duty, high acceleration, medium to high shock, high vibration	0.4 - 0.1

LOAD CAPACITIES, LIFE ESTIMATE, AND SIZING/SELECTION

Example Loading Scenarios

Scenario 1

$$F_A = \text{Resultant axial force}$$

$$F_{A1} = \frac{F(x-a)}{x}$$

$$F_{A2} = \frac{Fa}{x}$$

$$F = \text{Applied force}$$

$$a = \text{Distance from force to wheel}$$

$$x = \text{Track vee apex spacing distance}$$

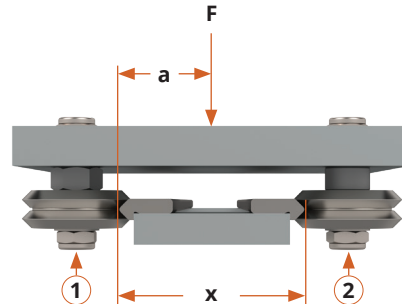

Scenario 2

$$F_A = \text{Resultant axial force}$$

$$F_{A1} = \frac{F(x+a)}{x}$$

$$F_{A2} = \frac{-Fa}{x}$$

$$F = \text{Applied force}$$

$$a = \text{Distance from track vee apex to force}$$

$$x = \text{Track vee apex spacing distance}$$

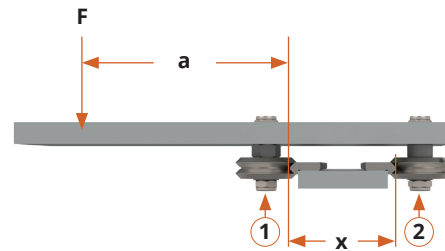

Scenario 3

$$F_A = \text{Resultant axial force}$$

$$F_{A1} = \frac{-Fa}{x}$$

$$F_{A2} = \frac{Fa}{x}$$

$$F_R = \text{Resultant radial force}$$

$$F_{R1} = F$$

$$F = \text{Applied force}$$

$$a = \text{Distance from force to wheel}$$

$$x = \text{Track vee apex spacing distance}$$

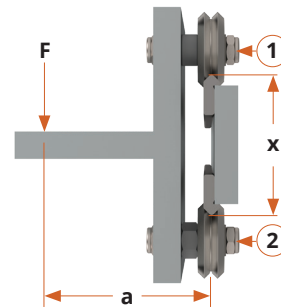

Example: Scenario 3

Using Scenario 3's loading configuration with two concentric wheels on the top track (1) and two eccentric wheels on the bottom track (2):

$$F = 200 \text{ lbs}$$

$$a = 15 \text{ inches}$$

$$x = 5 \text{ inches}$$

$$F_{A1} = \frac{-200(15)}{5} = -600 \text{ lbs, or } -300 \text{ lbs per concentric wheel}$$

$$F_{A2} = \frac{200(15)}{5} = 600 \text{ lbs, or } 300 \text{ lbs per eccentric wheel}$$

$$F_{R1} = 200 \text{ lbs, or } 100 \text{ lbs per wheel}$$

MOUNTING

Mounting Dimensions and Formulas

When fabricating a DualVee® linear guide from components the following formulas are applicable for mating wheel plate and track plate designs.

For sizes 1 through 4XL DualVee® single-edge track with equivalent sized guide wheels:

Inboard mounting (see Fig. 1): $A = B + X$

Outboard mounting (see Fig. 2): $A = C - X$

Exterior mounting (see Fig. 3): $A = D - Y$

WHERE **A** = Distance between wheel plate hole centers
B & C = Distance between track reference edges
D = Distance between the theoretical sharp of 90° exterior angles
X & Y = Size-specific dimension given in the table to the right

Dimensions				
DUALVEE® WHEEL SIZE	X		Y	
	(IN)	(MM)	(IN)	(MM)
1	.875	22.20	.935	23.72
2	1.375	34.90	1.438	36.47
3	2.000	50.80	2.125	53.95
4	2.624	66.60	2.750	69.85
4XL	3.124	79.35	3.500	88.90

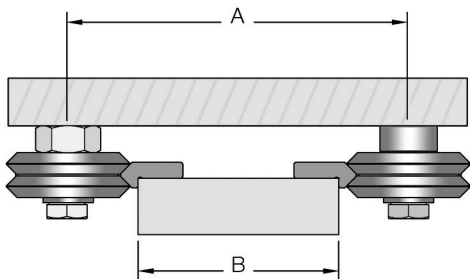

FIG. 1
INBOARD MOUNTING

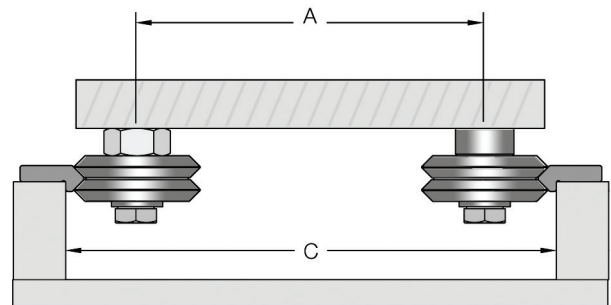

FIG. 2
OUTBOARD MOUNTING

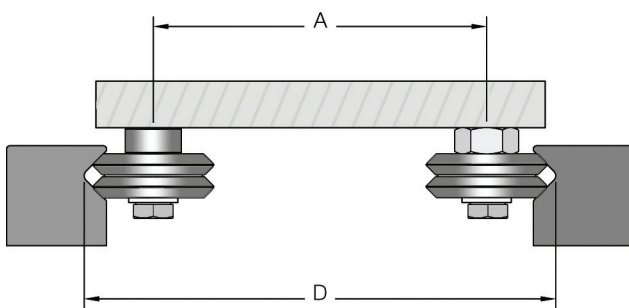
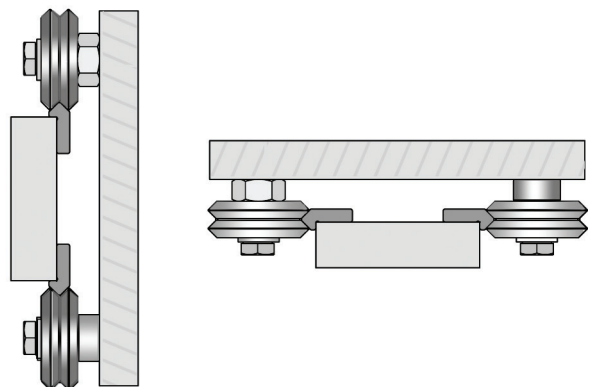

FIG. 3
EXTERIOR MOUNTING



MOUNTING ORIENTATIONS

Notes:

- Information above uses the same size DualVee® track and wheel except for size 4XL which uses W4XL guide wheel with size T4 track.
- Side views shown only; length of wheel plates can be any length required.
- It is recommended that wheel plates be constructed with concentric bushings on one side of the plate and eccentric bushings on the opposing side. Place concentric wheels on highest loaded side if applicable.

MOUNTING

Machining for Mounting Studded Guide Wheels

Suggested machining for mounting studded wheels (SWS series and SWI polymer) is shown below:

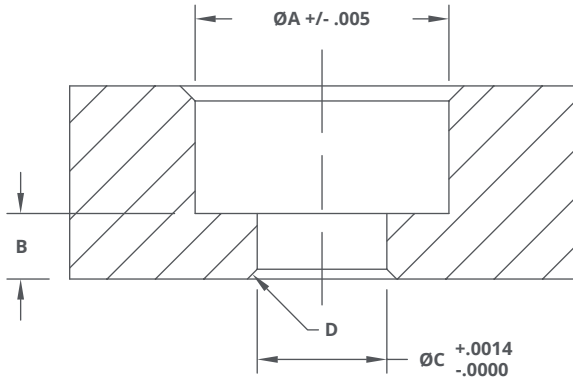

ECCENTRIC STUD
HOLE GEOMETRY

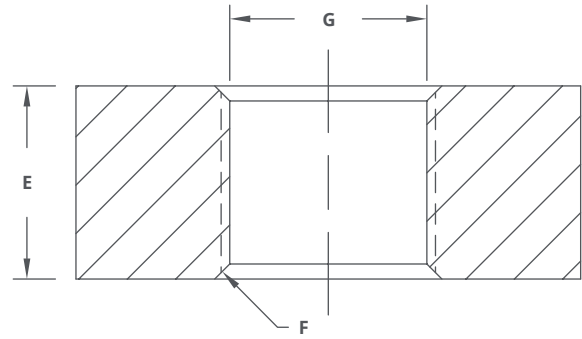

CONCENTRIC STUD
HOLE GEOMETRY

Dimensions

WHEEL SIZE	C'BORE DIAMETER	REMAINING MATERIAL	REAMED HOLE DIAMETER	REAMED HOLE CHAMFER	MINIMUM THICKNESS	CHAMFER	THREAD
	A	B MIN	C	D	E	F	G
0	\varnothing .500 [12.7]	.097 [2.46]	\varnothing .2215 [5.63]	90° TO \varnothing .264 [6.70]	.305 [7.75]	90° TO \varnothing .248 [6.30]	M6 x 1.0
1	\varnothing .610 [15.49]	.095 [2.41]	\varnothing .2505 [6.36]	90° TO \varnothing .293 [7.44]	.342 [8.69]	90° TO \varnothing .329 [8.36]	M8 x 1.25
2	\varnothing .770 [19.56]	.129 [3.28]	\varnothing .3775 [9.59]	90° TO \varnothing .420 [10.67]	.459 [11.66]	90° TO \varnothing .410 [10.41]	M10 x 1.5
3	\varnothing .906 [23.01]	.205 [5.21]	\varnothing .4244 [10.78]	90° TO \varnothing .467 [11.86]	.615 [15.62]	90° TO \varnothing .490 [12.45]	M12 x 1.75
4	\varnothing 1.100 [27.94]	.271 [6.88]	\varnothing .5025 [12.76]	90° TO \varnothing .545 [13.84]	.846 [21.49]	90° TO \varnothing .570 [14.48]	M14 x 2.0

Values are in inches [millimeters]

MOUNTING

Track Mounting

As a matter of good engineering practice the DualVee® components should not be used where their wear or failure could cause personal injury.

Track Flatness, Straightness, and Parallelism

In most DualVee® applications, accuracy plays a small role in the successful implementation of a guide wheel system. The flatness, straightness, and parallelism of the plate or bar to which the DualVee® track is attached (bolted) determine the accuracy of the system. Cold finished or extruded bar or plate is adequate for many applications. The DualVee® track incorporates a mounting shoulder to locate the track on the bar or plate.

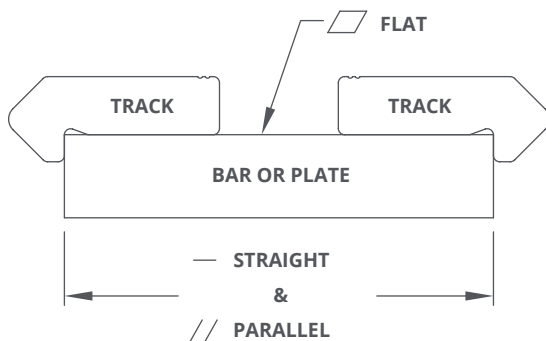

Greater accuracy can be obtained by using a plate or bar that has been ground flat and parallel on the mounting surfaces. To achieve straightness and flatness characteristics to within N grade accuracy levels is fairly routine ($\pm .004$ inch; $\pm .10$ mm). In fact, accuracies as high as $\pm .001$ inch (.03 mm) can be achieved using carefully prepared mounting surfaces in relatively short stroke applications (1-3 feet; 0.3-1 m). For designs requiring accuracy levels of $\pm .005$ inch and better, mounting surfaces must be prepared straight and flat, and appropriate doweling or reference edge assembly techniques should be employed.

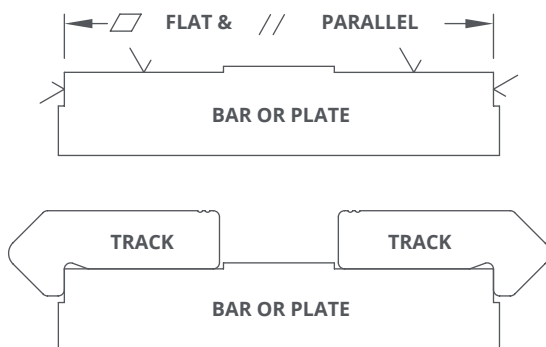

Track Staggering for Long Travel Lengths (DualVee®)

Precut lengths of track are not suitable for butting end to end. Please contact an Applications Engineer when track lengths longer than the maximum available single piece lengths are required. Track that is suitable for butting is available upon request. When constructing track systems longer than 20 feet, the joints on parallel tracks should be staggered for greater accuracy and smoothness.

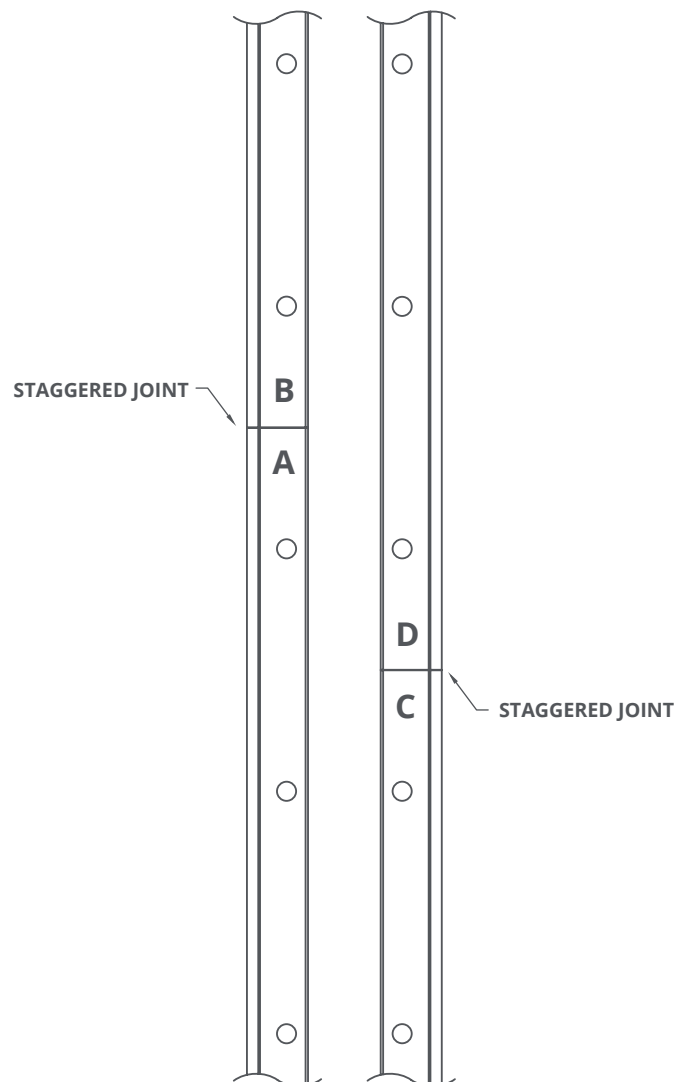

PRELOADING AND ADJUSTMENT

Benefits of Preloading

Typically, in a guide wheel and carriage application, there should be two concentric mounted wheels and the rest of the wheels should be on eccentric mounts. The eccentric type guide wheels are used to create a cam action to preload the guide wheels against one side of the guide track.

Normal adjustment is obtained by rotating the eccentric bushing, journal, or stud feature until all free play is removed from the carriage assembly. When the eccentrics are adjusted and the carriage plate is held firmly in place, one should be able to rotate by hand any one of the four guide wheels against the mating track. If rotation is not possible the preload should be reduced accordingly.

Preloading enhances system rigidity, linear accuracy, and repeatability while reducing vibration and noise. Proper preloading reduces loading variation on the guide wheels, resulting in longer system life.

Tools for Preloading DualVee® Guide Wheels

For DualVee® guide wheels with swaged studs, a special open end flat wrench and a socket wrench are required.

For DualVee® guide wheels with separate bushings and fasteners, two open end wrenches are required.

Although there are slightly different tools required for each type of DualVee® guide wheel, the process is the same for all of them.

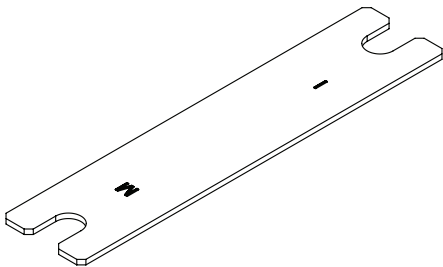

DualVee Adjustment Wrench (Inch and Metric)

Size 0: BAW0

Size 1: BAW1

Size 2: BAW2

Size 3: BAW3

Size 4: BAW4

Wheel Preload

Generally, wheel preload is used to eliminate play between the wheel and track. Preload equals the radial load when the system is not loaded by another outside force. Preload can be determined by:

$$\text{Preload} = \left(\frac{\text{BF}}{\text{CoF}} \right) - F_R$$

BF = Breakaway force

CoF = Coefficient of friction

F_R = Resultant radial force

Caution must be used when applying preload because too much preload on the wheels can cause undue stress and can lead to premature failure. The rated radial value should never be exceeded by the preload and subsequent radial loads applied to the wheel when in service. Note that in a four guide wheel assembly sustaining a load that runs along a linear beam, preload on the wheels cannot compensate for deflection on the beam.

PRELOADING AND ADJUSTMENT

DualVee® Preloading Instructions

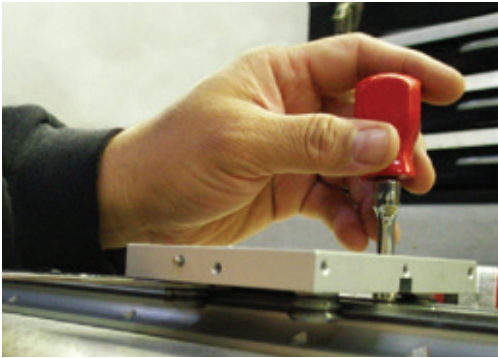

FIGURE 1



FIGURE 2

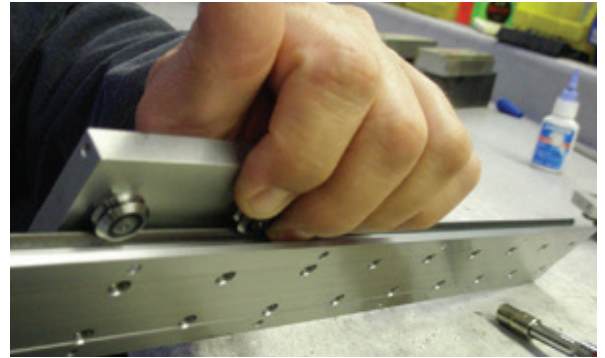

FIGURE 3

Step 1: Begin by placing the carriage on the track assembly with the concentric wheels fully tightened and the eccentric wheels finger-tightened within their mounting holes. Using one hand, insert the open end wrench between the eccentric wheel and the mounting plate to engage the hex flats of the bushing or stud on the wheel. Use the other hand to hold the open end wrench or socket wrench on the wheel's fastener (see Figures 1 and 2).

Step 2: Use the wrench to slowly turn the hex clockwise until resistance is felt—this indicates that the wheel is contacting the track. Then, with the wrench still held in position with one hand, tighten the eccentric wheel's fastener to lock the wheel into the adjusted position. This clockwise assembly orientation reduces the likelihood of the wheel loosening and moving out of its adjusted position because any subsequent radial load between the wheel and track will cause a clockwise, self-tightening torque to develop on the wheel fastener.

Step 3: To check the level of preload, slowly move the carriage, applying pressure only in the direction of motion. As the carriage moves, try to prevent one wheel from rotating by carefully applying pressure to it with a thumb. If the wheel skids easily the preload is too low.

Step 4: Manually slide the carriage along the entire length of the system to determine whether there are any noticeable variations in rolling resistance. If there are, readjust the eccentric wheel as necessary. If the variation is unacceptably large, the tracks are likely not parallel enough and will need to be realigned.

DualVee® guide wheels have substantial load carrying capacities and will become smoother under load. Use the palm of your hand to apply downward pressure on the adjusted carriage when sliding along the track.

Step 5: If there is more than one eccentric wheel on the carriage, repeat Steps 2 through 4 with all of the other eccentric wheels. Once all wheels are adjusted, recheck all wheels, concentric and eccentric, for preload using the stationary carriage wheel rotation and sliding resistance methods described above, and readjust if necessary.

Recommended preload torque for nuts on eccentric studs

SWS and SWI series

- Size 0 - 6 lb-ft (8Nm)
- Size 1 - 8 lb-ft (11Nm)
- Size 2 - 19 lb-ft (25Nm)
- Size 3 - 30 lb-ft (41Nm)
- Size 4 - 45 lb-ft (61Nm)

SWA series

- Size 0 - 2lb-ft (3Nm)
- Size 1 - 6lb-ft (8Nm)
- Size 2 - 23 lb-ft (31Nm)
- Size 3 - 36 lb-ft (49Nm)
- Size 4 - 50 lb-ft (68Nm)

Journals

- Size 0 - 9 lb-ft (12Nm)
- Size 1 - 9 lb-ft (12Nm)
- Size 2 - 25 lb-ft (34Nm)
- Size 3 - 33 lb-ft (45Nm)
- Size 4 - 45 lb-ft (61Nm)
- Size 4XL - 68 lb-ft (92Nm)

MadeWell[®] Series



***Radial Vee Wheels
and Crown Rollers***

LOAD CAPACITIES, LIFE ESTIMATE, AND SIZING/SELECTION

Several factors influence the service life; the methodology accounts for the size of the bearing elements and the load orientation and magnitude. The equation is based upon clean and well lubricated track conditions; so for applications where lubrication is prohibitive, a derating factor must be applied. Maximum velocity, acceleration rates, duty cycle, stroke length, environmental conditions, the presence of shock and vibration, and extreme temperature ranges can also impact service life. As such, the sizing method is considered only as a guideline.

If assistance is required in resolving specific loads into the resultant reaction forces at the guide wheel interface, contact our Applications Engineering staff for support.

Step 1: Calculate the radial and axial loads reflected to each guide wheel

All standard considerations involved in statics calculations must be accounted for, including inertial forces, gravitational forces, external forces such as tool pressure, guide wheel spacing, and magnitude and direction of the payload. Any external forces that generate a reaction through the wheel/ track interface must also be considered.

Step 2: Calculate the load factor for the most heavily loaded guide wheel

Bearings should be sized such that $L_F \leq 1$. The most heavily loaded bearing will have the highest load factor.

$$L_F = \frac{F_A}{L_A} + \frac{F_R}{L_R}$$

- WHERE**
- L_F = Load factor
 - F_A = Resultant axial load on the radial wheel
 - L_A = Axial working load capacity of radial wheel
 - F_R = Resultant radial load on the radial wheel or crown roller
 - L_R = Radial working load capacity of radial wheel or crown roller

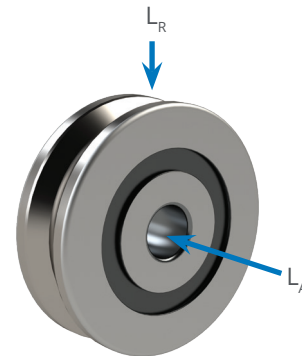

Working Load Capacities

Crown Rollers

WHEEL SIZE	WHEEL MATERIAL	WORKING RADIAL LOAD CAPACITY L_R	
		N	lbf
0	Polymer	28	6
1	Polymer	55	12
	Steel	1220	274
2	Polymer	70	16
	Steel	2650	596
3	Steel	5900	1326

Radial Wheels

WHEEL SIZE	WORKING RADIAL LOAD CAPACITY L_R		WORKING AXIAL LOAD CAPACITY L_A	
	N	lbf	N	lbf
1	670	151	138	31
2	1500	337	320	72
3	3700	832	800	180

*Crown rollers are not designed for axial loading conditions

LOAD CAPACITIES, LIFE ESTIMATE, AND SIZING/SELECTION

Step 3:

Calculate life estimate by applying the load factor to the load/life equation below

Due to varying application load and speed parameters and environmental conditions, the adjustment factor (A_f) must be applied to the life equation.

The Life Estimate below shares units with the Life Constant.

Adjustment Factor (A_f)

Application conditions include: contamination, duty, speed, cycle, acceleration, shock, presence of lubrication

CONDITIONS	A_f
<i>Clean, adequate lubrication, low duty, low shock, low vibration</i>	1.0 - 0.7
<i>Moderate contamination, medium duty, medium shock, low to medium vibration</i>	0.7 - 0.4
<i>Heavy contamination, limited lubrication, high duty, high acceleration, medium to high shock, high vibration</i>	0.4 - 0.1

$$\text{Life Estimate} = \left(\frac{L_c}{(L_f)^3} \right) A_f$$

WHERE

L_f = Load factor

L_c = Life constant

A_f = Adjustment factor

GUIDE WHEEL SIZE	LIFE CONSTANT L_c	
	INCHES TRAVEL LIFE	KILOMETERS OF TRAVEL LIFE
0	1.65 x 10 ⁶	41
1	2.19 x 10 ⁶	55
2	3.47 x 10 ⁶	88
3	5.18 x 10 ⁶	131

Notes:

1. See (DualVee® Life and Wear Resistance section) for notes on Wear resistance and lubrication.
2. See (DualVee® Preloading section) for preloading instructions.

MOUNTING

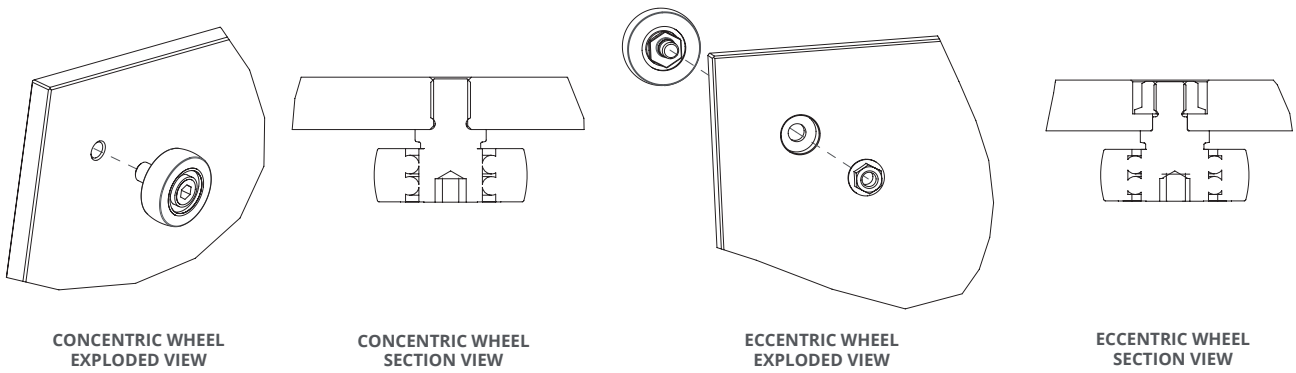

CONCENTRIC WHEEL
EXPLODED VIEW

CONCENTRIC WHEEL
SECTION VIEW

ECCENTRIC WHEEL
EXPLODED VIEW

ECCENTRIC WHEEL
SECTION VIEW

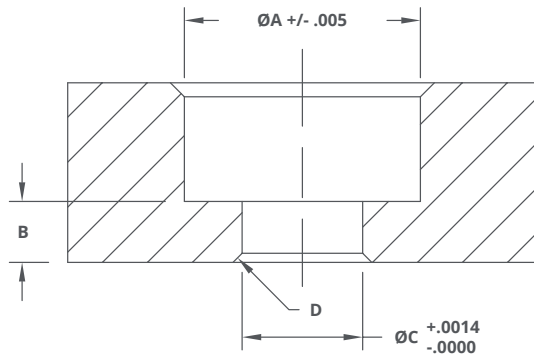

ECCENTRIC STUD
HOLE GEOMETRY

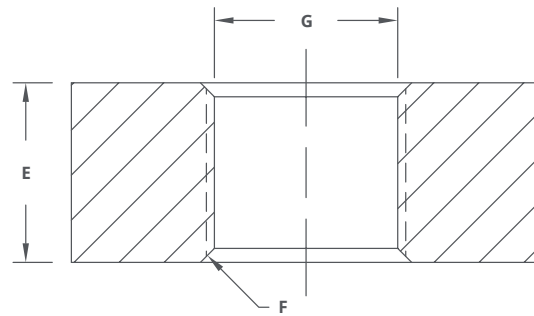

CONCENTRIC STUD
HOLE GEOMETRY

Dimensions

WHEEL SIZE	C'BORE DIAMETER	REMAINING MATERIAL	REAMED HOLE DIAMETER	REAMED HOLE CHAMFER	MINIMUM THICKNESS	CHAMFER	THREAD
	A	B MIN	C	D	E	F	G
0	Ø.500 [12.7]	.097 [2.46]	Ø.2215 [5.63]	90° TO Ø.264 [6.70]	.305 [7.75]	90° TO Ø.248 [6.30]	M6 x 1.0
1	Ø.610 [15.49]	.095 [2.41]	Ø.2505 [6.36]	90° TO Ø.293 [7.44]	.342 [8.69]	90° TO Ø.329 [8.36]	M8 x 1.25
2	Ø.770 [19.56]	.129 [3.28]	Ø.3775 [9.59]	90° TO Ø.420 [10.67]	.459 [11.66]	90° TO Ø.410 [10.41]	M10 x 1.5
3	Ø.906 [23.01]	.205 [5.21]	Ø.4244 [10.78]	90° TO Ø.467 [11.86]	.615 [15.62]	90° TO Ø.490 [12.45]	M12 x 1.75
4	Ø1.100 [27.94]	.271 [6.88]	Ø.5025 [12.76]	90° TO Ø.545 [13.84]	.846 [21.49]	90° TO Ø.570 [14.48]	M14 x 2.0

Values are in inches [millimeters]



MinVee[®] ***Series***

***Miniature Linear
Guide Systems***

LOAD CAPACITIES, LIFE ESTIMATE, AND SIZING/SELECTION

Load/Life Relationship

This method of estimating the service life of MinVee® systems is based on the L10 life formula for bearings and supported by Bishop-Wisecarver's research and development spanning over thirty years. The load/life estimation accounts for the relative spacing of the Size 0 DualVee® guide wheels, as well as the orientation, location, and magnitude of the load. The methodology requires a basic understanding of the principles of statics and the ability to work with free body diagrams. Whenever possible, the load on the system should be predominantly supported the concentric wheels in the radial direction.

Other factors such as maximum velocity, acceleration rates, duty cycle, stroke length, environmental conditions, the presence of shock and vibration, and extreme temperature ranges can impact service life. As such, the sizing method should be considered only as a guideline for the sizing of DualVee®-based components and assemblies. The formula is based upon clean and well lubricated track conditions; for applications where lubrication is prohibitive, a derating factor must be applied. Oscillating motion resulting in less than one full revolution of the wheel under load can cause accelerated wear on the internal bearing elements. Testing of such systems is recommended to verify compatibility of the design with load/life requirements.

Steps for Checking Load/Life Capabilities

The following life equation is for the purpose of estimating the expected life of the wheel plate and track plate only. System drive components are not accounted for, but should also be considered using the information on the previous page.

Step 1: Calculate all forces applied to the wheel plate

Any forces applied on the wheel plate need to be considered, including inertial forces, gravitational forces, external forces such as tool pressure, impact loading, and payload. If assistance is required in resolving specific loads into the resultant reaction forces, please contact our Applications Engineering staff.

Step 2: Calculate the load factor for the wheel plate

$$L_F = \frac{F_R}{L_R} + \frac{F_A}{L_A} + \frac{T_P}{M_P} + \frac{T_Y}{M_Y} + \frac{T_R}{M_R} \leq 1$$

WHERE

- L_F = Load factor
- F_R = Resultant radial load
- F_A = Resultant axial load
- T_P = Resultant Pitch Moment Load
- T_Y = Resultant Yaw Moment Load
- T_R = Resultant Roll Moment Load
- L_R = Radial Working Load Capacity
- L_A = Axial Working Load Capacity
- M_P = Pitch Moment Load Capacity
- M_Y = Yaw Moment Load Capacity
- M_R = Roll Moment Load Capacity

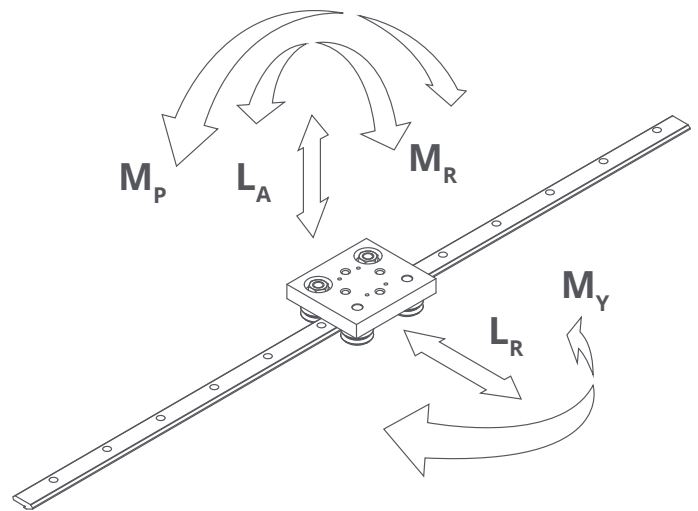

Load capacities can be found in the chart on the following page.

If the load factor is >1, consider using a MinVee® wheel plate with a higher load capacity, adding multiple wheel plates to distribute the load, using UtiliTrak® or LoPro® guide systems, or contacting our Applications Engineering staff.

Step 3: Calculate estimated life with adjustment factor

The Life Estimate below shares units with the Life Constant.

$$\text{Life Estimate} = \left(\frac{L_C}{(L_F)^3} \right) A_F$$

WHERE

- L_F = Load Factor
- L_C = Life Constant (41 km or 1.65 x 10⁶ in)
- A_F = Adjustment Factor

Adjustment Factor A_F

CONDITIONS	A_F
Clean, adequate lubrication, low duty, low shock, low vibration	1.0 - 0.7
Moderate contamination, medium duty, medium shock, low to medium vibration	0.7 - 0.4
Heavy contamination, limited lubrication, high duty, high acceleration, medium to high shock, high vibration	0.4 - 0.1

LOAD CAPACITIES AND LIFE ESTIMATE

Working Load Capacities

Working load capacities are based on empirical data on guide wheels used in general applications with dynamic load conditions.

STOCK CODE	WHEEL TYPE	TEMPERATURE RANGE	MAXIMUM SPEED	MAXIMUM ACCELERATION	WORKING RADIAL LOAD CAPACITY (L_R)	WORKING AXIAL LOAD CAPACITY (L_A)	PITCH MOMENT (M_P)	YAW MOMENT (M_Y)	ROLL MOMENT (M_R)	WEIGHT IN GRAMS (g)
MV0WPAP	Polymer Overmolded AISI 440C Stainless Steel, Shielded	-4°F to 248°F [-20°C to 120°C]	1 m/s	3 g [29 m/s ²]	65 N [12 lbf]	66.7 N [12 lbf]	1.4 Nm [12.4 lbf-in]	4.5 Nm [39.8 lbf-in]	1 Nm [8.8 lbf-in]	72
MV0WPA	AISI 52100 Carbon Steel, Shielded	-31°F to 248°F [-35°C to 120°C]	5 m/s	5g [49 m/s ²]	490 N [292 lbf]	540 N [112 lbf]	7.9 Nm [69.9 lbf-in]	8.6 Nm [76.1 lbf-in]	6.2 Nm [54.9 lbf-in]	84
MV0WPAX	AISI 52100 Carbon Steel, Sealed	-22°F to 212°F [-30°C to 100°C]								
MV0WPA-SS227	AISI 440C Stainless Steel, High Temperature, Shielded	-22°F to 500°F [-30°C to 260°C]								

Wheel plate assemblies are made from clear anodized 6061-T6 aluminum and include stainless steel lubricator housings with felt track wipers. Working load capacities are based on 41 km (approximately 25.5 miles) service life at 23°C or 73°F and 50% humidity.

MOUNTING

MinVee® components should not be used where their wear or failure could cause personal injury.

Track Mounting

In most MinVee® applications, accuracy plays a small role in the successful implementation of a guide wheel system. The flatness and straightness of the plate or bar to which the MinVee® track is attached (bolted) determines the accuracy of the system. Cold finished or extruded bar or plate is adequate for many applications. The MinVee® track incorporates a mounting shoulder to locate the track on the bar or plate.

Greater accuracy can be obtained by using a plate or bar that has been ground flat and perpendicular on the mounting surfaces. To achieve straightness and flatness characteristics to within N grade accuracy levels is fairly routine ($\pm .004$ inch; $\pm .10$ mm). In fact, accuracies as high as $\pm .001$ inch (.03 mm) can be achieved using carefully prepared mounting surfaces in relatively short stroke applications (1-3 feet; 0.3-1 m). For designs requiring accuracy levels of $\pm .005$ inch and better, mounting surfaces must be prepared straight and flat, and appropriate doweling or reference edge assembly techniques should be employed.

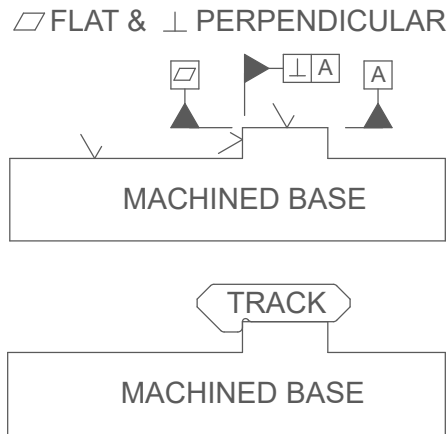
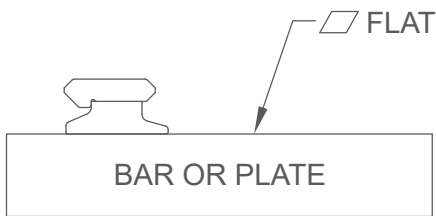

Mounting Suggestions

Top Mount

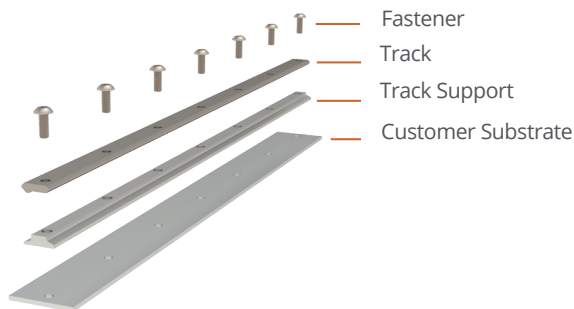
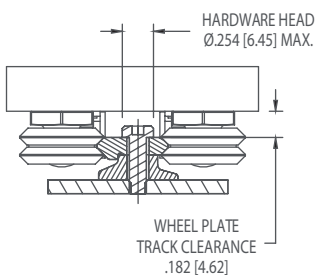

Bottom Mount

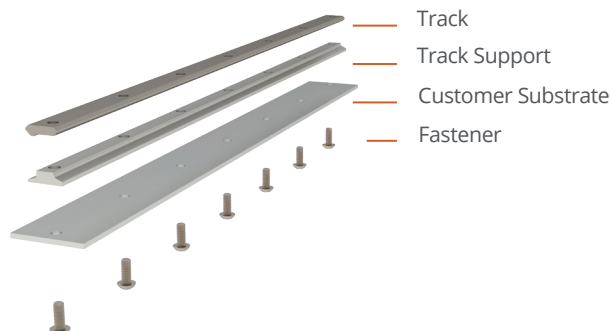
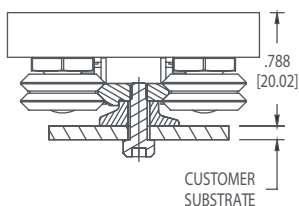



UtiliTrak[®] ***Series***

Linear Guide Systems

SYSTEM CONFIGURATION

The UtiliTrak® vee guide can be employed to accept loads in all orientations. However, it is primarily intended to support loads in the radial plane. It is good practice to orient the slide such that the two outside wheels support the load radially. Each wheel plate includes an arrow pointing towards the optimal direction of load orientation. Loads oriented in this direction will produce a radial load on each of the concentric stud mounted guide wheels. The crown roller should be subjected to radial loads only.

RECOMMENDED

1A Vee/C channel with direct loading

The vee channel can be used on its own to support radial or axial loading. The C channel only supports radial loads and must be accompanied with a vee channel.

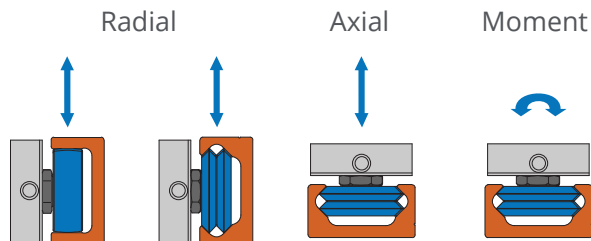

1B Face-to-face vee and C channel

Together, the vee and C channels stabilize radial loads and applied moments. The vee channel also constrains the axial motion of the bridged assembly.

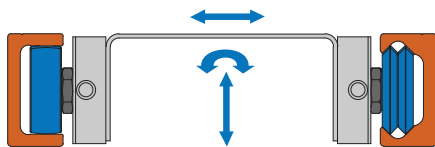

1C Back-to-back vee and C channel

Similar to 1B, the channels stabilize radial loads and applied moments while mounted back-to-back.

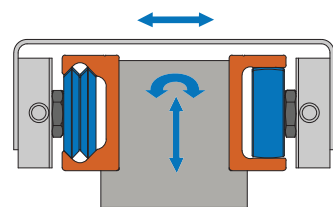

1D C channel facing vee channel (90 degrees)

The vee channel stabilizes in its radial direction. The C channel also stabilizes in its own radial direction and supports applied moments.

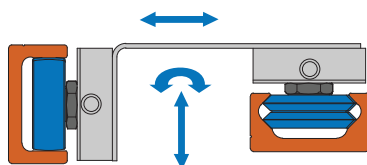

NON-RECOMMENDED

2A C channel with direct loading

The C channel does not support axial loads or applied moments, only radial loads. A C channel should not be used on its own in the axial load direction.

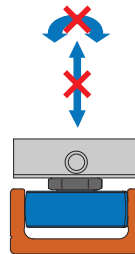

2B Face-to-face vee channel

The bridge is over-constrained in both the axial and radial directions due to the precise fit of the vee guide wheels. This configuration requires high precision mounting to prevent binding. This setup requires compliance built into the bridge attachment, or alignment of parallel rails within 0.002".

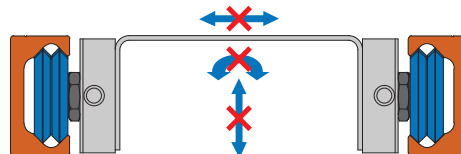

2C Side-to-side C channels

The bridge is unsupported in the axial direction by the C channels. Even when the bearings are loaded radially, the assembly drifts in the axial direction.

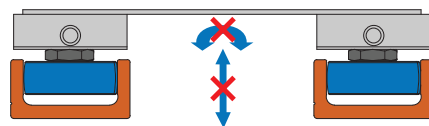

2D Vee facing C channel (90 degrees)

Though seemingly similar to 1D, the orientation of the channel provides little support for moments applied to the bridge.

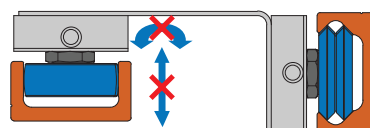

LOAD CAPACITIES, LIFE ESTIMATE, AND SIZING/SELECTION

Wheel Plate Load Capacity and Mass

SERIES	WHEEL SIZE	# OF WHEELS	RADIAL L_R		AXIAL L_A^*		PITCH M_P^*		YAW M_Y		ROLL M_R^*		MASS (g)		
			N	LBF	N	LBF	N-M	LBF-FT	N-M	LBF-FT	N-M	LBF-FT	90° VEE	CROWN	VEE/CROWN
PW Series (Polymer)	0	3	53	12	38	9	0.6	0.5	0.6	0.5	0.2	0.1	46	47	-
		4	53	12	46	10	21.1	15.6	1.8	1.3	0.4	0.3	60	60	-
		5	63	14	54	12	21.1	15.6	1.8	1.3	0.4	0.3	90	90	-
	1	3	107	24	76	17	2.0	1.5	2.0	1.5	0.5	0.4	92	94	-
		4	107	24	91	20	61.5	45.4	5.1	3.8	1.0	0.7	120	120	-
		5	127	30	107	24	61.5	45.4	5.1	3.8	1.0	0.7	160	160	-
	2	3	142	32	94	21	3.6	2.7	3.2	2.4	1.2	0.9	243	246	-
		4	142	32	113	25	124.9	92.1	9.3	6.8	2.3	1.7	315	315	-
		5	169	38	133	30	124.9	92.1	9.3	6.8	2.3	1.7	340	340	-
VC Series (Carbon) & SW Series (Carbon and Stainless)	1	3	2440	549	719	162	18	13.3	30.5	22.5	7.0	5.2	114	121	121
		4	2440	549	862	194	32.3	23.8	45.8	33.8	9.8	7.2	163	195	173
		5	2900	652	1014	228	32.3	23.8	45.8	33.8	12.6	9.3	181	220	193
	2	3	5300	1191	1475	332	58	42.8	100	73.8	22.7	16.7	330	320	348
		4	5300	1191	1770	398	107	78.9	150	110.6	31.8	23.5	479	522	503
		5	6300	1416	2080	468	107	78.9	150	110.6	40.9	30.2	543	598	573
	3	3	11800	2653	5100	1147	229	168.9	346	255.2	118	87	943	910	999
		4	11800	2653	6122	1376	408	300.9	519	382.8	165.2	121.8	1370	1478	1446
		5	14040	3156	7140	1605	408	300.9	519	382.8	212.4	156.7	1533	1665	1632
SW Series High Temp. & Low Temp. (Stainless)	1	3	1952	439	575	129	14.4	10.6	24.4	18	5.6	4.1	114	-	-
		4	1952	439	690	155	25.8	19.1	36.6	27	7.8	5.8	163	-	-
		5	2318	522	811	182	25.8	19.1	36.6	27	10.1	7.5	181	-	-
	2	3	4240	953	1180	265	46.4	34.2	80	59	18.2	13.4	330	-	-
		4	4240	953	1416	318	85.6	63.2	120	88.6	25.4	18.8	479	-	-
		5	5040	1133	1664	374	85.6	63.2	120	88.6	32.7	24.1	543	-	-
	3	3	9440	2122	4080	917	183.2	135.2	276.8	204.3	94.4	69.7	943	-	-
		4	9440	2122	4898	1101	326.4	240.9	415.2	306.4	132.2	97.5	1370	-	-
		5	11210	2525	5711	1284	326.4	240.9	415.2	306.4	169.9	125.4	1533	-	-
CR Series (Stainless)	1	3	2440	549	719	162	18	13.3	30.5	22.5	7.0	5.2	136	-	-
	2	3	5300	1191	1475	332	58	42.8	100	73.8	22.7	16.7	385	-	-
	3	3	11800	2653	5100	1147	229	168.9	346	255.2	118	87	1107	-	-
CR Series High Temp (Stainless)	1	3	1952	439	575	129	14.4	10.6	24.4	18	5.6	4.1	136	-	-
	2	3	4240	953	1180	265	46.4	34.2	80	59	18.2	13.4	385	-	-
	3	3	9440	2122	4080	917	183.2	135.2	276.8	204.3	94.4	69.7	1107	-	-

*Crown roller wheel plate assemblies do not have values for axial loading, pitch moment loading, and roll moment loading

LOAD CAPACITIES, LIFE ESTIMATE, AND SIZING/SELECTION

Load/Life Equation Variables

Several values are necessary for selecting a linear guide of sufficient capacity for a given application. Each UtiliTrak® Wheel Plate assembly has a rated load capacity that is based upon the individual guide wheel components. To select an appropriate size, the user must understand conditions in the operating environment and provide the expected forces that will be applied to the assembly. All forces need to be considered including inertial forces, gravitational forces, and external forces such as tool pressure, impact loading and payload.

Equation Variables:

L_F = Load Factor

F_A = Resultant Axial Load

F_R = Resultant Radial Load

L_A = Axial Load Capacity

L_R = Radial Load Capacity

T_P = Resultant Pitch Moment Load

T_Y = Resultant Yaw Moment Load

T_R = Resultant Roll Moment Load

M_P = Pitch Moment Load Capacity

M_Y = Yaw Moment Load Capacity

M_R = Roll Moment Load Capacity

A_F = Adjustment Factor, Environmental

L_C = Life Constant in kilometers

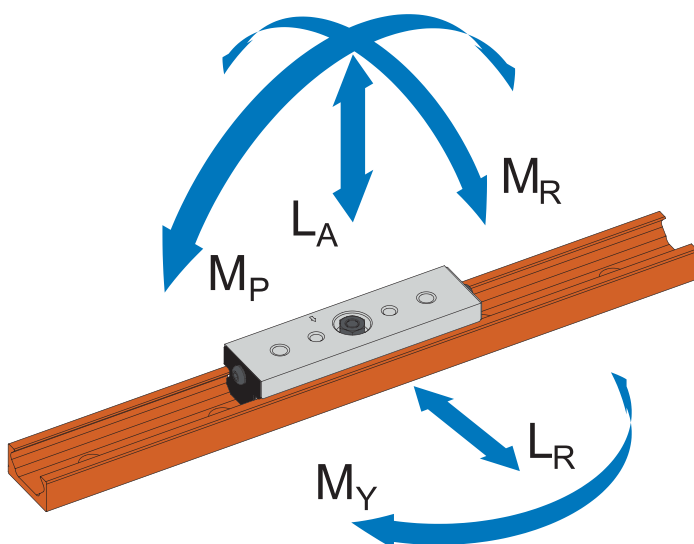

Load Capacity

The load capacity ratings in this guide are based on one million revolutions of the guide wheels. See the life constant, table 1, for L_C where one million revolutions is converted into kilometers of travel distance.

Guide wheels should be selected such that the load capacities are marginal. As a quick check the load factor, L_F , should be less than or equal to one. If L_F is greater than one, the next larger size should be chosen and L_F should be recalculated. Our application engineers are available to assist with the evaluation of specific loading applications.

Load/Life Estimate Calculations

The presented load/life calculation is derived from the basic L10 formula, a commonly used life estimate for rolling element bearings. The basic formula is adjusted to account for the unique loading conditions UtiliTrak® guide wheels are exposed to. The UtiliTrak® life estimate equation shares foundational assumptions with the DualVee® life equation, which has been successfully predicting safe life intervals for customers over the last 50 years.

The user must recognize that estimating the life of any rolling element bearing is theoretical. Actual travel life is heavily dependent on application and environmental factors. The presented equations are a statistical method for determining the life in kilometers or millions of revolutions, that 90% of bearings are likely to survive under the recommended loads. Actual bearing life is highly dependent on the application. To determine the exact bearing life, it is necessary for the user to conduct application specific testing, in which a sufficiently large sample set of bearings are subjected to the exact conditions of the operation.

The life estimation procedure has been developed from bearing failure theory, empirical testing, and over 50 years of experience keeping the world in motion. It is provided to the user as a method to estimate the life of the UtiliTrak® product within a given application.

LOAD CAPACITIES, LIFE ESTIMATE, AND SIZING/SELECTION

UtiliTrak® Life Estimation Procedure

Step 1: Determine the radial and axial load as well as the roll, pitch and yaw moments acting on the wheel plate assembly.

Step 2: Select an appropriate size wheel plate assembly whose maximum load capacity and moment capacity values are greater than those calculated in step 1.

Step 3: Confirm that the Load Factor, L_F , is less than or equal to one using the values from steps 1 and 2. If L_F is greater than one, select the next larger size and recalculate.

$$L_F = \frac{F_A}{L_A} + \frac{F_R}{L_R} + \frac{T_P}{M_P} + \frac{T_Y}{M_Y} + \frac{T_R}{M_R} \leq 1$$

Step 4: Select the Life Constant, L_C , for the chosen wheel plate assembly from Table 1.

Step 5: Select an appropriate Adjustment Factor, A_F , for your intended application from Table 2.

Step 6: Calculate the Life Estimate using the equation below. Include the Load Factor, L_F , from step 3, the Life Constant, L_C , from step 4, and the Adjustment Factor, A_F , from step 5. The Life Estimate shares units with the Life Constant.

$$\text{Life Estimate} = \left(\frac{L_C}{(L_F)^3} \right) A_F$$

Step 7: If the calculated life estimate is lower than is required for the application, consider choosing the next larger wheel plate size, or select the 4 or 5 wheel version because they have higher capacity.

Table 1. Life Constant (L_C)

GUIDE WHEEL SIZE	LIFE CONSTANT L_C	
	INCHES TRAVEL LIFE	KILOMETERS OF TRAVEL LIFE
0	1.65 x 10 ⁶	41
1	2.19 x 10 ⁶	55
2	3.47 x 10 ⁶	88
3	5.18 x 10 ⁶	131

Table 2. Adjustment Factor (A_F)

CONDITIONS	A_F
Clean, adequate lubrication, low duty, low shock, low vibration	1.0 - 0.7
Moderate contamination, medium duty, medium shock, low to medium vibration	0.7 - 0.4
Heavy contamination, limited lubrication, high duty, high acceleration, medium to high shock, high vibration	0.4 - 0.1

CHANNEL MOUNTING

Range of Angular Misalignment (θ)

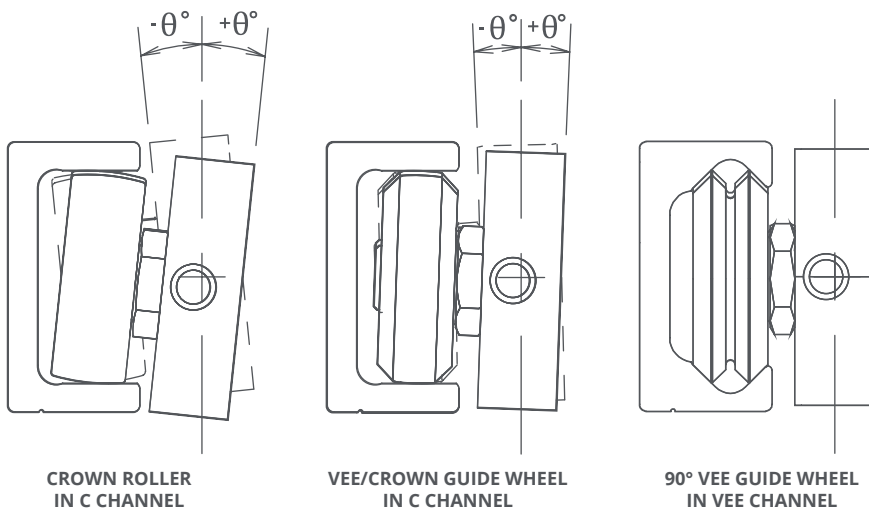

WHEEL PLATE SIZE	CROWN ROLLER IN C CHANNEL	VEE/CROWN IN C CHANNEL	90° VEE OR VEE/CROWN IN VEE CHANNEL
0	±3°	N/A	0°
1	±4°	±1.5°	0°
2	±6°	±2°	0°
3	±7°	±2°	0°

Range of Axial Misalignment (H)

Dimensions						
WHEEL PLATE SIZE	H_{MIN}		H_{MAX}		RANGE (H)	
	IN	MM	IN	MM	IN	MM
0	0.866	22	0.909	23.1	0.043	1.1
1	1.024	26	1.087	27.6	0.063	1.6
2	1.366	34.7	1.472	37.4	0.106	2.7
3	1.846	46.9	2.102	53.4	0.256	6.5

- Crown Rollers and Vee/Crown guide wheels float within C channels along the dimension shown.
- 90° Vee guide wheels are not designed to accommodate angular misalignment
- Range of Axial Misalignment = $H_{MAX} - H_{MIN}$

Accuracy

The precision of UtiliTrak® is defined differently than typical square rail recirculating ball guides. Square rail guides are designed primarily for “high end” positioning applications, such as machine tool guideways, Cartesian coordinate robotics, and precision XY inspection equipment. These guides are more rigidly defined in terms of the running parallelism of wheel plates to rail, and are measured as a function of rail length. The tight tolerances are achieved through grinding and finishing operations. UtiliTrak®, in contrast, has been developed for commercial applications.

As with any linear guide, installed accuracy is directly related to the straightness and flatness of the surface to which it is mounted. Because the guide will conform to the mounting surface, it is important for that surface to be more rigid than the UtiliTrak® channel.

In C channels:

Vee/Crown guide wheels allow for a smaller amount of angular misalignment than crown rollers

In vee channels:

Vee/Crown guide wheels and 90° Vee guide wheels are designed to provide rigidity without allowing angular misalignment

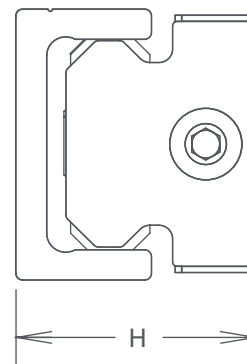

PRELOADING AND ADJUSTMENT

Fit up is pre-set at the factory (except for VC), but is easily field adjusted by rotating the eccentric guide wheels. This allows modification of running characteristics such as drag and breakaway force.

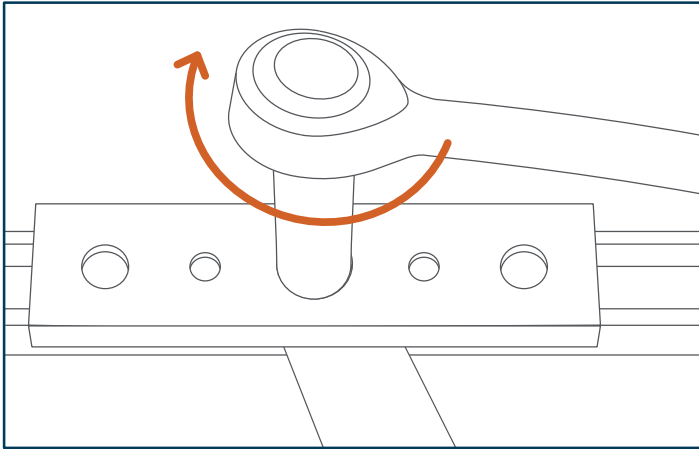

Fig. 1 - Fit up adjustment of a UtiliTrak® linear guide

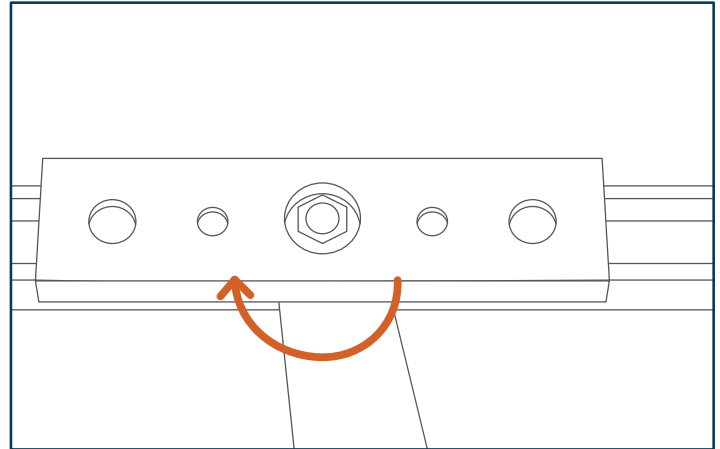

Fig. 2 - Fit up adjustment

Step 1: Fit up adjustment should be performed while wheel plate is engaged with the channel.

Step 2: Looking down on the top of the wheel plate, as shown in [Fig. 1](#), the eccentric stud is locked into place with a hex nut.

Step 3: Loosen the eccentric wheel/stud by turning the hex nut counter-clockwise with a socket wrench.

Step 4: When the wheel/stud is loose enough, it can be rotated with a wrench, as shown in Fig. 2. Rotating the eccentric wheel's stud will adjust the wheel location into or out of mesh with the channel.

Step 5: Begin with a small adjustment to the fit up and re-tighten the stud by turning the hex nut clockwise. If the fit up is too loose, the wheel plate will exhibit excessive play, such as rocking. If the fit up is too tight, the wheel plate will exhibit excessive drag. Move the wheel plate up and down the entire channel length to ensure that it does not feel too loose or tight at any given location along the channel.

MAINTENANCE

Lubrication

The presence of a lubricant between the UtiliTrak® guide wheel and track channel is necessary to achieve the life estimate presented. All UtiliTrak® wheel plates are provided complete with lubricating wiper caps consisting of an oil saturated felt within a housing. Lubricators should be periodically checked and re-oiled to ensure that a sufficient coating of lubricant is maintained on the channel guideway surfaces. The mating surfaces will feel slick to the touch when properly lubricated. If lubricating the guide wheel and track interfaces is unacceptable for the given application, our application engineers are available to assist in estimating a reduced life.

Standard wiper caps available on PW, SW, and VC Series wheel plates have a maximum operating temperature of 80°C (176°F). When used without wiper caps, wheel plate operating temperatures are dictated by their DualVee® wheels (see page 4).

Replacement

Bishop-Wisecarver recommends the complete replacement of UtiliTrak® wheel plate assemblies when the estimated travel life is reached. High quality guide wheel components have been known to survive significantly longer than their estimated service life, but doing so increases the risk of potential bearing failure and is not recommended. With a calculated life estimate it is possible to schedule the replacement of critical motion components.



LoPro[®]
Series

***Actuated Linear
Guidance System***

DRIVE SYSTEM LOAD CAPACITIES

BELT SYSTEM	SYSTEM SIZE	BELT SIZE	DRIVE END PULLEYS PITCH DIAMETER		WORKING TENSILE LOAD CAPACITY		BELT TEETH SHEAR STRENGTH FORMULA (N)* (APPROX.)	BELT TEETH SHEAR STRENGTH AT V=0 m/s (N)*	BELT TEETH SHEAR STRENGTH AT V=5 m/s (N)*
			in	mm	N	lbf			
			1	10AT5	1.128	28.7			
2S	16AT5	1.504	38.2	1008	227	$F = 672 - 1.06V^3 + 18.4V^2 - 120V$	672	392	
2L	16AT10	3.133	79.6	2085	469	$F = 1407 - 2.59V^3 + 34.2V^2 - 208V$	1407	867	
3	20AT10	3.759	95.5	2606	586	$F = 1761 - 2.98V^3 + 373V^2 - 230V$	1761	1128	
4	32AT10	3.759	95.5	4170	937	$F = 2818 - 4.80V^3 + 60.0V^2 - 369V$	2818	1805	

V = Linear speed in m/s.

*The belt teeth shear strength is the permissible linear force which the drive pulley can apply to the carriage. The sum of the linear force applied to the wheel plate and the belt pretension load must not exceed the working tensile load capacity. If the wheel plate will be subjected to shock loads, divide the permissible linear force by a safety factor of 1.4 (light shock) to 2 (high shock).

CHAIN SYSTEM	SYSTEM SIZE	CHAIN SIZE (SINGLE STRAND)	DRIVE END SPROCKETS			STATIC/SLOW SPEED WORKING CHAIN LOAD CAPACITY*				WORKING LOAD CAPACITY AT 0.5 m/s*			
			PITCH DIAMETER		NUMBER OF TEETH	STEEL		STAINLESS STEEL		STEEL		STAINLESS STEEL	
			in	mm		N	lbf	N	lbf	N	lbf	N	lbf
			1	25	.966	24.5	24.5	431	97	347	78	267	60
2S	35	1.449	36.8	36.8	1036	233	841	189	618	139	494	392	
2L	35	3.111	79.0	79.0	1036	233	841	189	645	145	516	867	
3	40	3.672	93.3	93.3	1975	444	1481	333	1152	259	863	1128	
4	50	3.599	91.4	91.4	3261	733	2322	522	1788	402	1272	1805	

*Working load varies with speed. Contact Bishop-Wisecarver for specific application information.

LEAD SCREW SYSTEM	SYSTEM SIZE	SCREW DIAMETER		NUT TYPE	DYNAMIC THRUST CAPACITY	
		in			N	lbf
		1	1/4		BY	222
2	3/8		NTBY	44	9.9	
			BY	334	75.0	
3	1/2		NTBY	89	20.0	
			BY	444	100.0	
4	3/4		BY	1000	225.0	
			VHDY	1556	350.0	

BALL SCREW SYSTEM	SYSTEM SIZE	SCREW DIAMETER	LEAD	BASIC WHEEL PLATE MAX SYSTEM TRAVEL LENGTH*	WIPER WHEEL PLATE MAX SYSTEM TRAVEL LENGTH*	DYNAMIC THRUST LOAD CAPACITY	
		MM	MM	MM	MM	N	LBS
		2	10	2	912	914	1250
3	892			914	2800	629.4	
3	12	5	1458	1449	2300	517.0	
		10	1512	1499	1500	337.2	
4	16	5	1363	1361	5600	1258.9	
		10	1349	1347	5800	1303.8	
		20	2023	2016	8600	1933.3	

* System configured with ball screw drive nut toward Fix End

LOAD CAPACITIES, LIFE ESTIMATE, AND SIZING/SELECTION

Load/Life Relationship

This method of estimating the service life of LoPro® systems is based on the L10 life formula for bearings and supported by Bishop-Wisecarver's research and development spanning over thirty years. The load/life estimation accounts for the size and relative spacing of the DualVee® guide wheels, as well as the orientation, location, and magnitude of the load. The methodology requires a basic understanding of the principles of statics and the ability to work with free body diagrams. Whenever possible, the load on the system should be predominantly supported the concentric wheels in the radial direction.

Other factors such as maximum velocity, acceleration rates, duty cycle, stroke length, environmental conditions, the presence of shock and vibration, and extreme temperature ranges can impact service life. As such, the sizing method should be considered only as a guideline for the sizing of DualVee®-based components and assemblies. The formula is based upon clean and well lubricated track conditions; for applications where lubrication is prohibitive, a derating factor must be applied. Oscillating motion resulting in less than one full revolution of the wheel under load can cause accelerated wear on the internal bearing elements. Testing of such systems is recommended to verify compatibility of the design with load/life requirements.

Sizing and Selection Steps

The following life equation is for the purpose of estimating the expected life of the wheel plate and track plate only. System drive components are not accounted for, but should also be considered using the information on the previous page.

Step 1: Calculate all forces applied to the wheel plate

Any forces applied on the wheel plate need to be considered, including inertial forces, gravitational forces, external forces such as tool pressure, impact loading, and payload. If assistance is required in resolving specific loads into the resultant reaction forces, please contact our Applications Engineering staff.

Step 2: Calculate the load factor for the wheel plate

$$L_F = \frac{F_R}{L_R} + \frac{F_A}{L_A} + \frac{T_P}{M_P} + \frac{T_Y}{M_Y} + \frac{T_R}{M_R} \leq 1$$

- WHERE**
- L_F = Load factor
 - F_R = Resultant radial load
 - F_A = Resultant axial load
 - T_P = Resultant Pitch Moment Load
 - T_Y = Resultant Yaw Moment Load
 - T_R = Resultant Roll Moment Load
 - L_R = Radial Working Load Capacity
 - L_A = Axial Working Load Capacity
 - M_P = Pitch Moment Load Capacity
 - M_Y = Yaw Moment Load Capacity
 - M_R = Roll Moment Load Capacity

If the load factor is >1, consider a larger size system.

Step 3: Calculate estimated life with adjustment factor

The Life Estimate below shares units with the Life Constant.

$$\text{Life Estimate} = \left(\frac{L_C}{(L_F)^3} \right) A_F$$

- WHERE**
- L_F = Load Factor
 - L_C = Life Constant
 - A_F = Adjustment Factor

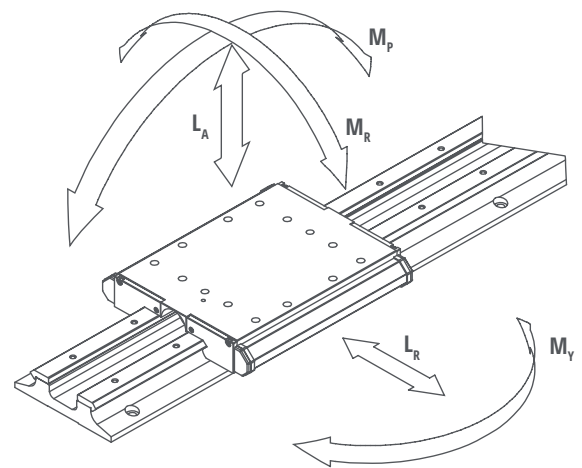

Load Capacities					
SYSTEM SIZE	RADIAL LOAD CAPACITY L_R	AXIAL LOAD CAPACITY L_A	PITCH MOMENT CAPACITY M_P	YAW MOMENT CAPACITY M_Y	ROLL MOMENT CAPACITY M_R
	N	N	N•m	N•m	N•m
1	2391	988	26	62	27
2/2S/2L	5194	2450	95	202	100
3	11564	6668	346	599	372
4	19012	15684	1220	1478	1174

Life Constant L_C		
SYSTEM SIZE	INCHES OF TRAVEL LIFE	KILOMETERS OF TRAVEL LIFE
1	2.19×10^6	55
2/2S/2L	3.47×10^6	88
3	5.18×10^6	131
4	6.84×10^6	173

Adjustment Factor A_F	
CONDITIONS	A_F
Clean, adequate lubrication, low duty, low shock, low vibration	1.0 - 0.7
Moderate contamination, medium duty, medium shock, low to medium vibration	0.7 - 0.4
Heavy contamination, limited lubrication, high duty, high acceleration, medium to high shock, high vibration	0.4 - 0.1

SYSTEM INERTIA CALCULATIONS

LoPro® Belt System Inertia Calculations

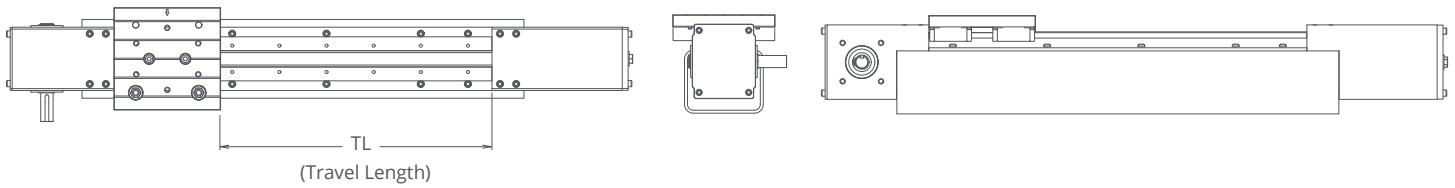

SIZE	SYSTEM INERTIA = (A + B + C)		
	INERTIA CONSTANT A	PAYLOAD MASS MULTIPLIER C ²	LENGTH DEPENDENT INERTIA B ¹
1	.234 lb•in ² [68.4 kg•mm ²]	.318 in ² x M [205 mm ² x M]	.00142 lb•in x TL [.0164 kg•mm x TL]
2S	1.21 lb•in ² [355 kg•mm ²]	.566 in ² x M [365 mm ² x M]	.00380 lb•in x TL [.0438 kg•mm x TL]
2L	7.15 lb•in ² [2090 kg•mm ²]	2.45 in ² x M [1580 mm ² x M]	.0275 lb•in x TL [.317 kg•mm x TL]
3	22.9 lb•in ² [6690 kg•mm ²]	3.53 in ² x M [2280 mm ² x M]	.0515 lb•in x TL [.593 kg•mm x TL]
4	49.9 lb•in ² [14600 kg•mm ²]	3.53 in ² x M [2280 mm ² x M]	.0792 lb•in x TL [.912 kg•mm x TL]

Notes:

1. Values are in Imperial [Metric].
2. TL (Travel Length) must be in mm for metric calculation, inches for English calculation.
3. M (Mass of payload on the carriage) must be in kg for metric calculation, lbm for English calculation.

SYSTEM INERTIA CALCULATIONS

LoPro® Chain System Inertia Calculations

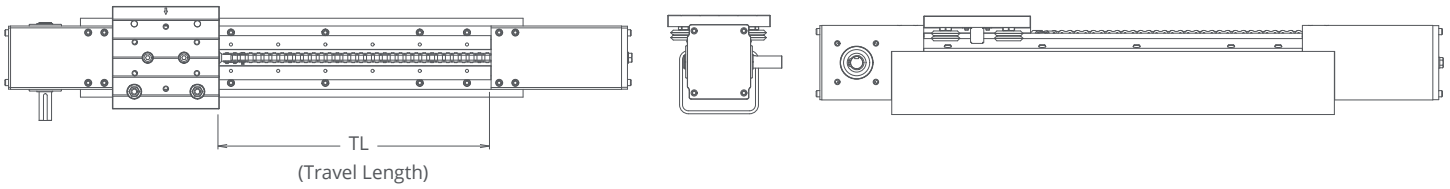

SIZE	SYSTEM INERTIA = (A + B + C)		
	INERTIA CONSTANT A	PAYLOAD MASS MULTIPLIER C ²	LENGTH DEPENDENT INERTIA B ¹
1	.256 lb•in ² [74.8 kg•mm ²]	.234 in ² x M [151 mm ² x M]	.0037 lb•in x TL [.0421 kg•mm x TL]
2S	1.62 lb•in ² [474 kg•mm ²]	.525 in ² x M [339 mm ² x M]	.020 lb•in x TL [.230 kg•mm x TL]
2L	9.78 lb•in ² [2860 kg•mm ²]	2.42 in ² x M [1560 mm ² x M]	.092 lb•in x TL [1.06 kg•mm x TL]
3	31.7 lb•in ² [9260 kg•mm ²]	3.36 in ² x M [2170 mm ² x M]	.241 lb•in x TL [2.78 kg•mm x TL]
4	60.2 lb•in ² [17600 kg•mm ²]	3.24 in ² x M [2090 mm ² x M]	.388 lb•in x TL [4.47 kg•mm x TL]

Notes:

1. Values are in Imperial [Metric].
2. TL (Travel Length) must be in mm for metric calculation, inches for English calculation.
3. M (Mass of payload on the carriage) must be in kg for metric calculation, lbm for English calculation.

SYSTEM INERTIA CALCULATIONS

LoPro® Lead Screw System Inertia Calculations

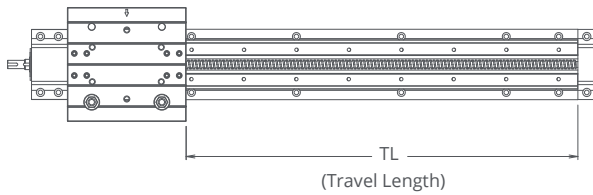

SIZE	DRIVE ELEMENT	SYSTEM INERTIA = (A + B + C)			
		INERTIA CONSTANT A		PAYLOAD MASS MULTIPLIER C ²	LENGTH DEPENDENT INERTIA B ¹
		BASIC WHEEL PLATE	WIPER WHEEL PLATE		
1	1/4" x 2mm	.00414 lb•in ² [1.21 kg•mm ²]	.0041 lb•in ² [1.2 kg•mm ²]	.000157 in ² x M [.101 mm ² x M]	.00011 lb•in x TL [.00127 kg•mm x TL]
	1/4" x 10mm	.00684 lb•in ² [2 kg•mm ²]	.00609 lb•in ² [1.78 kg•mm ²]	.00392 in ² x M [2.53 mm ² x M]	
2	3/8" x 5mm	.03249 lb•in ² [9.5 kg•mm ²]	.0322 lb•in ² [9.42 kg•mm ²]	.000981 in ² x M [0.633 mm ² x M]	.00056 lb•in x TL [.00645 kg•mm x TL]
	3/8" x 10mm	.0421 lb•in ² [12.3 kg•mm ²]	.04 lb•in ² [11.7 kg•mm ²]	.00566 in ² x M [3.65 mm ² x M]	
	3/8" x 25mm	.08 lb•in ² [23.4 kg•mm ²]	.0718 lb•in ² [21 kg•mm ²]	.0245 in ² x M [15.8 mm ² x M]	
3	1/2" x 5mm	.0831 lb•in ² [24.3 kg•mm ²]	.0828 lb•in ² [24.2 kg•mm ²]	.000981 in ² x M [.633 mm ² x M]	.00178 lb•in x TL [.0205 kg•mm x TL]
	1/2" x 10mm	.0985 lb•in ² [28.8 kg•mm ²]	.0954 lb•in ² [27.9 kg•mm ²]	.00392 in ² x M [2.53 mm ² x M]	
	1/2" x 25mm	.205 lb•in ² [60 kg•mm ²]	.184 lb•in ² [53.8 kg•mm ²]	.0245 in ² x M [15.8 mm ² x M]	
	5/8" x 8mm	.109 lb•in ² [31.9 kg•mm ²]	.108 lb•in ² [31.5 kg•mm ²]	.00251 in ² x M [1.62 mm ² x M]	
	5/8" x 16mm	.148 lb•in ² [43.3 kg•mm ²]	.14 lb•in ² [41 kg•mm ²]	.01 in ² x M [6.48 mm ² x M]	
4	3/4" x 5mm	.327 lb•in ² [95.5 kg•mm ²]	.326 lb•in ² [95.4 kg•mm ²]	.000981 in ² x M [.633 mm ² x M]	.00903 lb•in x TL [.104 kg•mm x TL]
	3/4" x 10mm	.363 lb•in ² [106 kg•mm ²]	.359 lb•in ² [105 kg•mm ²]	.00392 in ² x M [2.53 mm ² x M]	
	3/4" x 24mm	.581 lb•in ² [170 kg•mm ²]	.561 lb•in ² [164 kg•mm ²]	.0226 in ² x M [14.6 mm ² x M]	
	3/4" x 50mm	1.47 lb•in ² [430 kg•mm ²]	1.39 lb•in ² [405 kg•mm ²]	.0981 in ² x M [63.3 mm ² x M]	

Notes:

1. Values are in Imperial [Metric].
2. TL (Travel Length) must be in mm for metric calculation, inches for English calculation.
3. M (Mass of payload on the carriage) must be in kg for metric calculation, lbm for English calculation.

SYSTEM INERTIA CALCULATIONS

LoPro® Ball Screw System Inertia Calculations

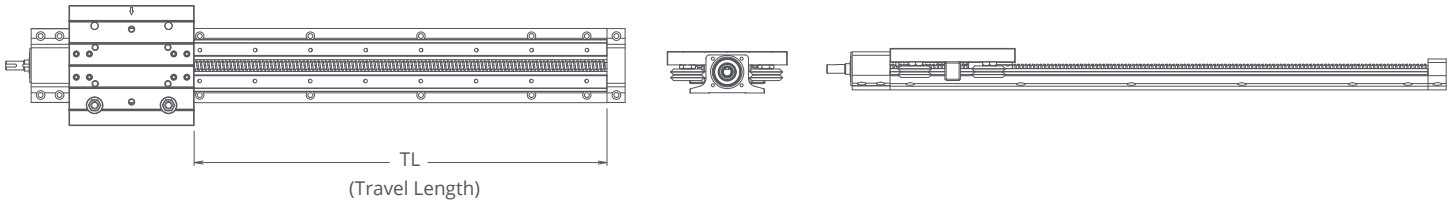

SIZE	DRIVE ELEMENT	SYSTEM INERTIA = (A + B + C)			
		INERTIA CONSTANT A		PAYLOAD MASS MULTIPLIER C ²	LENGTH DEPENDENT INERTIA B ¹
		BASIC WHEEL PLATE	WIPER WHEEL PLATE		
2	10mm x 2mm	.0315 lb•in ² [9.2 kg•mm ²]	.0315 lb•in ² [9.21 kg•mm ²]	.000157 in ² x M [0.101 mm ² x M]	.00068 lb•in x TL [.00783 kg•mm x TL]
	10mm x 3mm	.0319 lb•in ² [9.33 kg•mm ²]	.0319 lb•in ² [9.31 kg•mm ²]	.000353 in ² x M [.228 mm ² x M]	
3	12mm x 5mm	.0807 lb•in ² [23.6 kg•mm ²]	.08 lb•in ² [23.4 kg•mm ²]	.000981 in ² x M [.633 mm ² x M]	.00142 lb•in x TL [.0164 kg•mm x TL]
	12mm x 10mm	.0964 lb•in ² [28.2 kg•mm ²]	.0934 lb•in ² [27.3 kg•mm ²]	[2.53 mm ² x M] .00392 in ² x M	
4	16mm x 5mm	.282 lb•in ² [82.4 kg•mm ²]	.281 lb•in ² [82.2 kg•mm ²]	.000981 in ² x M [.633 mm ² x M]	.00448 lb•in x TL [.0516 kg•mm x TL]
	16mm x 10mm	.316 lb•in ² [92.5 kg•mm ²]	.313 lb•in ² [91.6 kg•mm ²]	.00392 in ² x M [2.53 mm ² x M]	
	20mm x 5mm	.345 lb•in ² [101 kg•mm ²]	.345 lb•in ² [101 kg•mm ²]	.000981 in ² x M [.633 mm ² x M]	.0109 lb•in x TL [.126 kg•mm x TL]

Notes:

1. Values are in Imperial [Metric].
2. TL (Travel Length) must be in mm for metric calculation, inches for English calculation.
3. M (Mass of payload on the carriage) must be in kg for metric calculation, lbm for English calculation.

SYSTEM MASS CALCULATIONS

Calculations are approximate, and depict the maximum mass (kg) for each size, dependent on travel length (TL, in meters). Exact calculations will vary depending on system configuration.

MOUNT SYSTEM	SIZE	DRIVE SYSTEM			
		BELT	CHAIN	LEAD SCREW	BALL SCREW
Aluminum Beam	1	$7.78 \times TL + 2.26$	$6.78 \times TL + 1.93$	$6.52 \times TL + 1.28$	N/A
	2	N/A	N/A	$9.20 \times TL + 3.28$	$9.25 \times TL + 3.06$
	2S	$10.94 \times TL + 5.63$	$9.68 \times TL + 4.77$	N/A	N/A
	2L	$12.49 \times TL + 8.30$	$12.23 \times TL + 7.24$	N/A	N/A
	3	$25.17 \times TL + 17.02$	$23.18 \times TL + 15.52$	$21.21 \times TL + 8.30$	$21.08 \times TL + 7.76$
	4	N/A	N/A	N/A	N/A
Steel Beam	1	$7.50 \times TL + 2.20$	$6.51 \times TL + 1.87$	$6.25 \times TL + 1.23$	N/A
	2	N/A	N/A	$9.54 \times TL + 3.32$	$9.88 \times TL + 2.38$
	2S	$12.30 \times TL + 4.99$	$11.07 \times TL + 4.01$	N/A	N/A
	2L	$13.15 \times TL + 8.62$	$12.90 \times TL + 7.34$	N/A	N/A
	3	$25.18 \times TL + 16.27$	$25.17 \times TL + 15.99$	$19.31 \times TL + 7.75$	$19.18 \times TL + 7.22$
	4	$41.15 \times TL + 26.26$	$37.56 \times TL + 29.21$	$26.22 \times TL + 20.82$	$25.55 \times TL + 18.14$
Un-mounted	1	$3.16 \times TL + 1.55$	$2.16 \times TL + 1.21$	$1.90 \times TL + 0.65$	N/A
	2	N/A	N/A	$3.32 \times TL + 2.00$	$3.38 \times TL + 1.78$
	2S	$5.07 \times TL + 4.31$	$4.82 \times TL + 3.14$	N/A	N/A
	2L	$5.07 \times TL + 6.67$	$4.82 \times TL + 5.61$	N/A	N/A
	3	$11.18 \times TL + 12.93$	$9.16 \times TL + 11.49$	$7.19 \times TL + 4.75$	$7.06 \times TL + 4.21$
	4	$17.96 \times TL + 24.19$	$15.38 \times TL + 20.14$	$12.18 \times TL + 15.46$	$11.50 \times TL + 13.12$

TECHNICAL REFERENCE

Accuracy/Repeatability

The accuracy of a LoPro® linear system is dependent upon the mounting surface preparation and the technique used to align the track. LoPro® systems can achieve straightness and flatness characteristics to within .004in/foot (0.1mm/300mm) when mounting surfaces are adequately prepared. Straight line accuracy of beam mounted LoPro® systems are subject to the industry standard straightness and twist tolerances associated with extruded or hot formed sections. As such, the highest straight line precision can be achieved by bolting an unsupported LoPro® system to a carefully prepared flat mounting surface with a machined reference.

Fit-up Adjustment

The concentric bushings/wheels determine the alignment of the system, while the eccentric bushings/wheels provide adjustment. Normal adjustment is obtained by rotating the eccentric bushings until all free play is removed from the carriage assembly. When the eccentrics are adjusted and the carriage plate is held firmly in place, one should be able to rotate, by hand, any of the four guide wheels in the system against its mating track. If rotation is not possible, preload on the wheels should be reduced accordingly. Over-tightening of the eccentric adjustment could exert a force greater than the load rating of the wheel and result in premature bearing failure.

Lubrication

Lubrication is the key to maximizing service life in any rolling contact linear bearing design. Internally, DualVee® guide wheels are lubricated for life with an extreme pressure, corrosion resistant grease. As such, the main consideration with regards to lubrication is the wheel/track interface. Typically, a light machine oil or an extreme pressure grease does well to minimize wear, stick slip, and corrosion.

Lubrication will maximize the load capacity of an individual bearing element. As such, for any specific loading condition, the presence of lubrication on the guide ways will significantly increase the service life over a non-lubricated configuration under the same loads. Lubrication will also increase the maximum linear velocity that a guide wheel-based bearing arrangement can travel. In high cycling applications where high speed or acceleration rates are present, lubrication of the wheel/track interface is strongly recommended.

LoPro® systems are available with two standard wheel plate designs that use oil-saturated felt to lubricate the track. Wiper wheel plates come with lubricating wiper caps. Basic wheel plates are available with either wheel covers or track lubricators.

Operating Temperature

For standard LoPro® systems (including extreme temperature options), operating temperature ranges vary by drive type:

DRIVE SYSTEM	OPERATING TEMPERATURE
BELT	-25°C to 80°C
CHAIN	-10°C to 60°C
LEAD SCREW	-40°C to 120°C
BALL SCREW	-53°C to 80°C

MOTION SOLUTIONS FROM BISHOP-WISECARVER ARE LIMITED ONLY BY YOUR IMAGINATION

Components & Accessories

DualVee®
MadeWell®
GV3
SL2
PRT2
HDS2
HDRT
MCS
Motor Mounts
Gantry Brackets
Wrenches

Manual Linear Guide Systems

DualVee®
UtiliTrak®
MinVee®
GV3
Simple Select®
SL2
HDS2
MHD
HTS

Actuated Linear Guide Systems

LoPro®
XLA™
ECO60™
SlickStick™
SteadyRail™
HDLS
HDCS
PDU2
DAPDU2
SBD
PSD
SDM
DLS

Rotary Guide Systems

PRT2
DTS2
DTS
ALR
HDRT
1-Trak
GFX

Custom Solutions

Extruded Profile Guides
Custom Bearings
Custom Subassemblies
Engineering Services
Large Diameter Ring Guides and Track



BWC.COM

 **BISHOP
WISECARVER**
Expertly Designed, Delivered to Perform

Contact

Phone: **(925) 439-8272**
Email: **Sales@bwc.com**

2104 Martin Way
Pittsburg, CA 94565