



Slider Type

RCP3

RCA2

RCP2

RCA

ERC2

RCS2



RCP3-SA2 RCP3-SA3 RCP3-SA4 RCP3-SA5 RCP3-SA6 ERC2-SA



RCP2-SA5 RCP2-SA6 RCP2-SA7 RCP2-SS7 RCP2-SS8 RCP2-BA7



RCA-SA4 RCA-SA5 RCA-SA6 RCS2-SS7 RCS2-SS8

RCP3 series Pulse Motor Type	Coupled Type	Aluminum Base	22mm width	RCP3-SA2AC	3
			28mm width	RCP3-SA2BC	5
			32mm width	RCP3-SA3C	7
			40mm width	RCP3-SA4C	9
			50mm width	RCP3-SA5C	11
			60mm width	RCP3-SA6C	13
	Side-Mounted Motor Type	Aluminum Base	22mm width	RCP3-SA2AR	15
			28mm width	RCP3-SA2BR	17
			32mm width	RCP3-SA3R	19
			40mm width	RCP3-SA4R	21
			50mm width	RCP3-SA5R	23
			60mm width	RCP3-SA6R	25

RCP2 series Pulse Motor Type	Coupled Type	Aluminum Base	52mm width	RCP2-SA5C	27
			58mm width	RCP2-SA6C	29
			73mm width	RCP2-SA7C	31
		Steel Base	60mm width	RCP2-SS7C	33
			80mm width	RCP2-SS8C	35
			High-Speed Type	80mm width	RCP2-HS8C
	Side-Mounted Motor Type	Aluminum Base	52mm width	RCP2-SA5R	39
			58mm width	RCP2-SA6R	41
			73mm width	RCP2-SA7R	43
		Steel Base	60mm width	RCP2-SS7R	45
			80mm width	RCP2-SS8R	47
			High-Speed Type	80mm width	RCP2-HS8R
	Belt Type		58mm width	RCP2-BA6/BA6U	51
68mm width			RCP2-BA7/BA7U	53	

ERC2 series	Slider Type	Straight Motor Type	58mm width	ERC2-SA6C	55
			68mm width	ERC2-SA7C	57

RCA2 series 24V Servo Motor Type	Coupled Type	Aluminum Base	32mm width	RCA2-SA3C	59
			40mm width	RCA2-SA4C	61
			50mm width	RCA2-SA5C	63
			60mm width	RCA2-SA6C	65
	Side-Mounted Motor Type	Aluminum Base	30mm width	RCA2-SA3R	67
			40mm width	RCA2-SA4R	69
			50mm width	RCA2-SA5R	71
			60mm width	RCA2-SA6R	73

RCA series 24V Servo Motor Type	Coupled Type	Aluminum Base	40mm width	RCA-SA4C	75	
			52mm width	RCA-SA5C	77	
			58mm width	RCA-SA6C	79	
	Built-in Type	Aluminum Base	40mm width	RCA-SA4D	81	
			52mm width	RCA-SA5D	83	
			58mm width	RCA-SA6D	85	
			Steel Base	40mm width	RCA-SS4D	87
				52mm width	RCA-SS5D	89
				58mm width	RCA-SS6D	91
	Side-Mounted Motor Type	Aluminum Base	40mm width	RCA-SA4R	93	
			52mm width	RCA-SA5R	95	
			58mm width	RCA-SA6R	97	

RCS2 series 200V Servo Motor Type	Coupled Type	Aluminum Base	40mm width	RCS2-SA4C	99		
			52mm width	RCS2-SA5C	101		
			58mm width	RCS2-SA6C	103		
			73mm width	RCS2-SA7C	105		
			Steel Base	60mm width	RCS2-SS7C	107	
			80mm width	RCS2-SS8C	109		
			Built-in Type	Aluminum Base	40mm width	RCS2-SA4D	111
					52mm width	RCS2-SA5D	113
	58mm width	RCS2-SA6D			115		
	Side-Mounted Motor Type	Aluminum Base	40mm width	RCS2-SA4R	117		
			52mm width	RCS2-SA5R	119		
			58mm width	RCS2-SA6R	121		
			73mm width	RCS2-SA7R	123		
			Steel Base	60mm width	RCS2-SS7R	125	
				80mm width	RCS2-SS8R	127	

- Slider Type
- Mini
- Standard
- Controllers Integrated
- Rod Type
- Mini
- Standard
- Controllers Integrated
- Table/Arm/Flat Type
- Mini
- Standard
- Gripper/Rotary Type
- Linear Servo Type
- Cleanroom Type
- Splash-Proof
- Controllers
- PMEC/AMEC
- PSEP/ASEP
- ROBO NET
- ERC2
- PCON
- ACON
- SCON
- PSEL
- ASEL
- SSEL
- XSEL
- Pulse Motor
- Servo Motor (24V)
- Servo Motor (200V)
- Linear Servo Motor

RCP3-SA2AC

ROBO Cylinder Mini Slider Type Coupled Motor 22mm Width Pulse Motor Lead Screw

■ Configuration: **RCP3** — **SA2AC** — **I** — **20P** — — — — —

Series	Type	Encoder	Motor	Lead	Stroke	Compatible Controllers	Cable Length	Option
I: Incremental * The Simple absolute encoder is also considered type "I".	20P: Pulse motor 20 □ size	4S: 4mm lead screw 2S: 2mm lead screw 1S: 1mm lead screw	25: 25mm 100: 100mm (25mm pitch increments)	P1: PCON RPCON PSEL P3: PMEC PSEP	N: None P: 1m S: 3m M: 5m X □ □ : Custom Length	NM: Reversed-home		

* See page Pre-35 for explanation of each code that make up the configuration name.

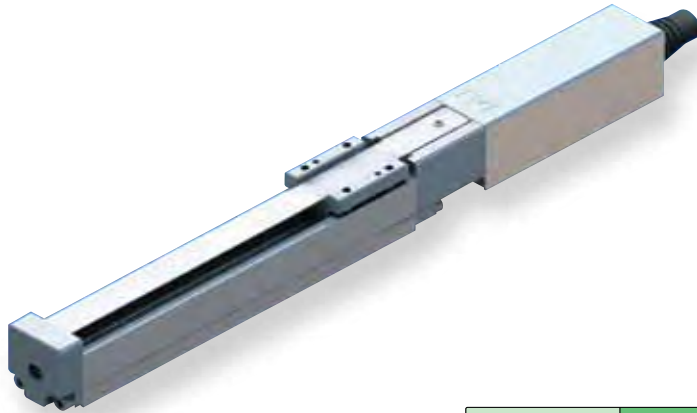

Technical References A-5

■ Speed vs. Load Capacity
Due to the characteristics of the pulse motor, the RCP3 series' load capacity decreases at high speeds. In the table below, check if your desired speed and load capacity are supported.

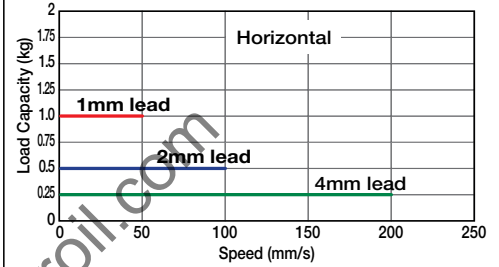

- POINT** Notes on Selection
- (1) The load capacity is based on operation at an acceleration of 0.2G. This the upper limit for the acceleration.
 - (2) The actuator cannot be used on its side or in a vertical orientation.
 - (3) If used in a dusty environment, the service life will decrease significantly.
 - (4) This model uses a lead screw, therefore please ensure that your usage is appropriate for its characteristics. (See page Pre-42.)

Actuator Specifications						Stroke and Maximum Speed			
■ Lead and Load Capacity						■ Stroke and Maximum Speed			
Model	Feed Screw	Lead (mm)	Max. Load Capacity		Positioning Repeatability (mm)	Stroke (mm)	Stroke		
			Horizontal (kg)	Vertical (kg)			Lead	25 (mm)	50 ~ 100 (mm)
RCP3-SA2AC-I-20P-4S-①-②-③-④	Lead screw	4	0.25	-	±0.05	25~100 (25 increments)	4	180	200
RCP3-SA2AC-I-20P-2S-①-②-③-④		2	0.5	-			2	100	
RCP3-SA2AC-I-20P-1S-①-②-③-④		1	1	-			1	50	

Legend ① Stroke ② Compatible Controller ③ Cable Length ④ Options (Unit: mm/s)

① Stroke List

Stroke (mm)	Standard Price
25	—
50	—
75	—
100	—

③ Cable List

Type	Cable Symbol	Standard Price
Standard (Robot Cables)	P (1m)	—
	S (3m)	—
	M (5m)	—
Special Lengths	X06 (6m) ~ X10 (10m)	—
	X11 (11m) ~ X15 (15m)	—
	X16 (16m) ~ X20 (20m)	—
		—

* The standard cable for the RCP3 is the robot cable.
* See page A-39 for cables for maintenance.

④ Option List

Name	Option Code	See Page	Standard Price
Reversed-home	NM	→ A-33	—

Actuator Specifications

Item	Description
Drive System	Lead screw (Ø4mm, C10 grade)
Lost Motion	0.3mm or less (initial value)
Base	Material: Aluminum (white alumite treated)
Guide	Slide guide
Ambient Operating Temp./Humidity	0~40°C, 85% RH or less (non-condensing)
Service Life	10 million cycles

Dimensions

CAD drawings can be downloaded from IAI website. www.intelligentactuator.com

For Special Orders

A-9



- *1: A motor-encoder cable is connected here. See page A-39 for details on cables.
- *2: During the homing operation, the slider moves to actuator's mechanical end, and then reverses. Therefore, watch for any interference with its surroundings.

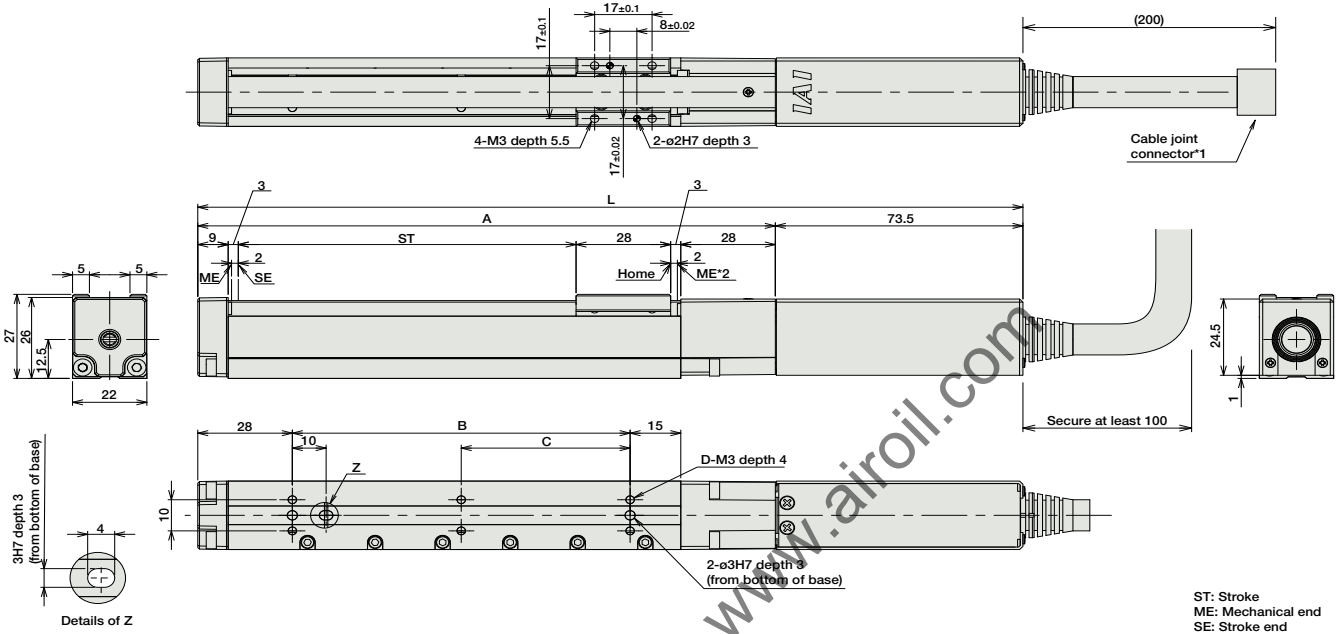

Dimensions/Weight by Stroke

Stroke	25	50	75	100
L	169.5	194.5	219.5	244.5
A	96	121	146	171
B	25	50	75	100
C	0	0	0	50
D	4	4	4	6
Weight (kg)	0.25	0.27	0.29	0.3

Compatible Controllers

The RCP3 series actuators can operate with the controllers below. Select the controller according to your usage.

Name	External View	Model	Description	Max. Positioning Points	Input Voltage	Power Supply Capacity	Standard Price	See Page
Solenoid Valve Type		PMEC-C-20PI-NP-2-①	Easy-to-use controller, even for beginners	3 points	AC100V AC200V	See P481	-	→ P477
		PSEP-C-20PI-NP-2-0	Operable with same signal as solenoid valve. Supports both single and double solenoid types.					→ P487
Splash-Proof Solenoid Valve Type		PSEP-CW-20PI-NP-2-0	No homing necessary with simple absolute type.					
Positioner Type		PCON-C-20PI-NP-2-0	Positioning is possible for up to 512 points	512 points	DC24V	2A Max.	-	
Safety-Compliant Positioner Type		PCON-CG-20PI-NP-2-0						
Pulse Train Input Type (Differential Line Driver)		PCON-PL-20PI-NP-2-0	Pulse train input type with differential line driver support	(-)	DC24V	2A Max.	-	→ P525
Pulse Train Input Type (Open Collector)		PCON-PO-20PI-NP-2-0	Pulse train input type with open collector support					
Serial Communication Type		PCON-SE-20PI-N-0-0	Dedicated to serial communication	64 points				
Field Network Type		RPCON-20P	Dedicated to field network	768 points				→ P503
Program Control Type		PSEL-C-1-20PI-NP-2-0	Programmed operation is possible. Can operate up to 2 axes	1500 points				→ P557

* This is for the single-axis PSEL.

* ① is a placeholder for the power supply voltage (1: 100V / 2: 100~240V).

RCP3-SA2BC

ROBO Cylinder Mini Slider Type Coupled Motor 28mm Width Pulse Motor Lead Screw

■ Configuration: **RCP3** — **SA2BC** — **I** — **20P** — — — — —

Series	Type	Encoder	Motor	Lead	Stroke	Compatible Controllers	Cable Length	Option
I: Incremental * The Simple absolute encoder is also considered type "I".	20P: Pulse motor 20 □ size	6S: 6mm lead screw 4S: 4mm lead screw 2S: 2mm lead screw	25: 25mm 150: 150mm (25mm pitch increments)	P1: PCON RPCON PSEL P3: PMEC PSEP	N: None P: 1m S: 3m M: 5m X □ □: Custom Length	NM: Reversed-home		

* See page Pre-35 for explanation of each code that make up the configuration name.

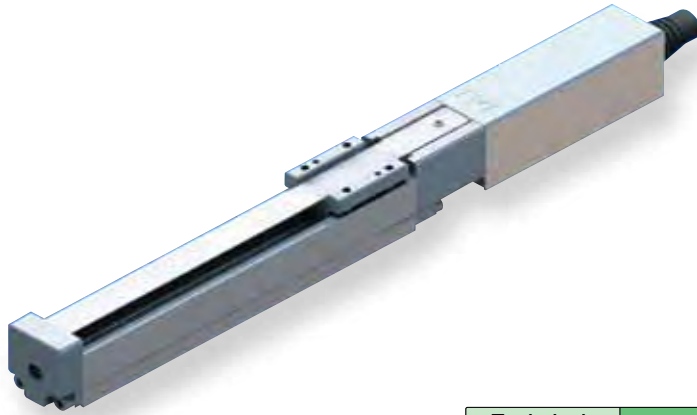

Technical References A-5

■ Speed vs. Load Capacity
Due to the characteristics of the pulse motor, the RCP3 series' load capacity decreases at high speeds. In the table below, check if your desired speed and load capacity are supported.

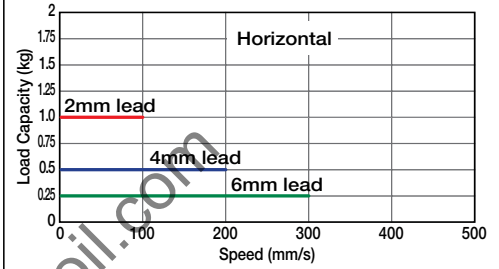

- The load capacity is based on operation at an acceleration of 0.2G. This is the upper limit for the acceleration.
- The actuator cannot be used on its side or in a vertical orientation.
- If used in a dusty environment, the service life will decrease significantly.
- This model uses a lead screw, therefore please ensure that your usage is appropriate for its characteristics. (See page Pre-42.)

Actuator Specifications

■ Lead and Load Capacity

Model	Feed Screw	Lead (mm)	Max. Load Capacity		Positioning Repeatability (mm)	Stroke (mm)
			Horizontal (kg)	Vertical (kg)		
RCP3-SA2BC-I-20P-6S-①-②-③-④	Lead screw	6	0.25	-	±0.05	25~150 (25 increments)
RCP3-SA2BC-I-20P-4S-①-②-③-④		4	0.5	-		
RCP3-SA2BC-I-20P-2S-①-②-③-④		2	1	-		

Legend ① Stroke ② Compatible Controller ③ Cable Length ④ Options

■ Stroke and Maximum Speed

Stroke / Lead	25 (mm)	50 (mm)	75~150 (mm)
	6	180	280
4	180	200	
2	100		

(Unit: mm/s)

① Stroke List

Stroke (mm)	Standard Price
25	-
50	-
75	-
100	-
125	-
150	-

③ Cable List

Type	Cable Symbol	Standard Price
Standard (Robot Cables)	P (1m)	-
	S (3m)	-
	M (5m)	-
Special Lengths	X06 (6m) ~ X10 (10m)	-
	X11 (11m) ~ X15 (15m)	-
	X16 (16m) ~ X20 (20m)	-
		-

* The standard cable for the RCP3 is the robot cable.

* See page A-39 for cables for maintenance.

④ Option List

Name	Option Code	See Page	Standard Price
Reversed-home	NM	→ A-33	-

Actuator Specifications

Item	Description
Drive System	Lead screw Ø6mm C10 grade
Lost Motion	0.3mm or less (initial value)
Base	Material: Aluminum (white alumite treated)
Guide	Slide guide
Ambient Operating Temp./Humidity	0~40°C, 85% RH or less (non-condensing)
Service Life	10 million cycles

Dimensions

CAD drawings can be downloaded from IAI website. www.intelligentactuator.com

For Special Orders A-9



- *1: A motor-encoder cable is connected here. See page A-39 for details on cables.
- *2: During the homing operation, the slider moves to actuator's mechanical end, and then reverses. Therefore, watch for any interference with its surroundings.

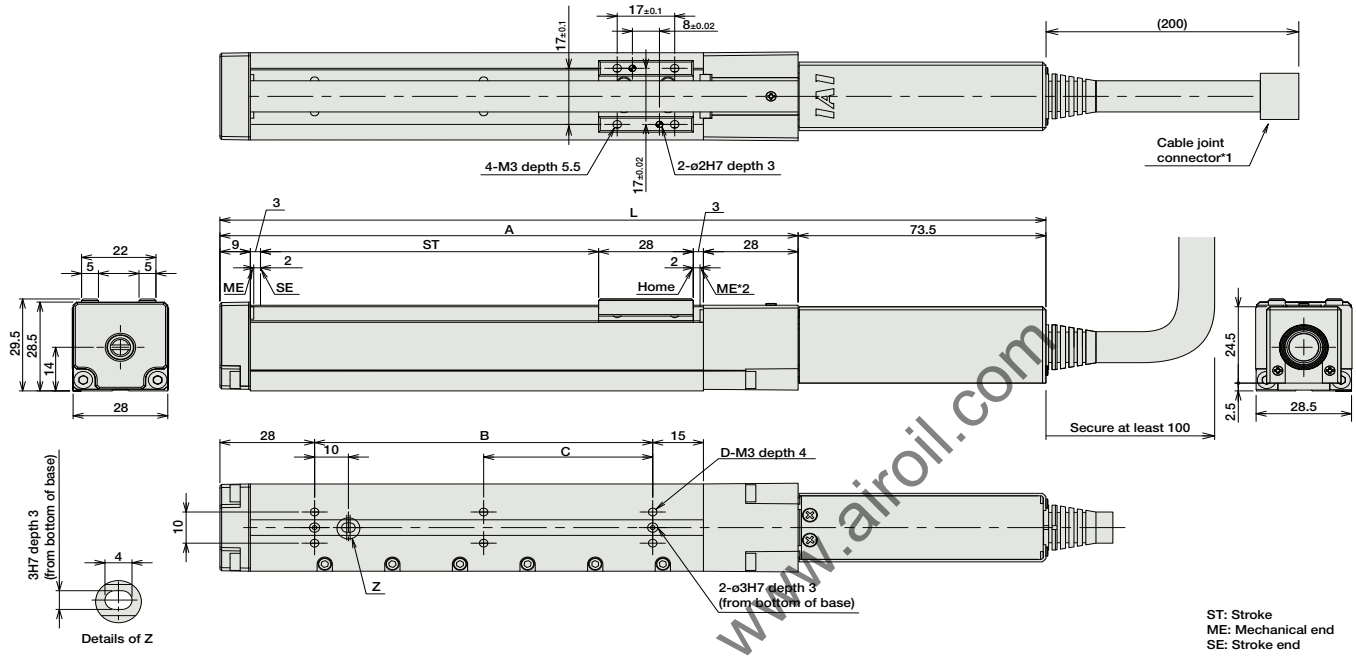

■ Dimensions/Weight by Stroke

Stroke	25	50	75	100	125	150
L	169.5	194.5	219.5	244.5	269.5	294.5
A	96	121	146	171	196	221
B	25	50	75	100	125	150
C	0	0	0	50	62.5	75
D	4	4	4	6	6	6
Weight (kg)	0.3	0.32	0.35	0.37	0.4	0.42

② Compatible Controllers

The RCP3 series actuators can operate with the controllers below. Select the controller according to your usage.

Name	External View	Model	Description	Max. Positioning Points	Input Voltage	Power Supply Capacity	Standard Price	See Page
Solenoid Valve Type		PMEC-C-20PI-NP-2-①	Easy-to-use controller, even for beginners	3 points	AC100V AC200V	See P481	—	→ P477
		PSEP-C-20PI-NP-2-0	Operable with same signal as solenoid valve. Supports both single and double solenoid types.				—	→ P487
Splash-Proof Solenoid Valve Type		PSEP-CW-20PI-NP-2-0	No homing necessary with simple absolute type.				—	
Positioner Type		PCON-C-20PI-NP-2-0	Positioning is possible for up to 512 points	512 points	DC24V	2A Max.	—	
Safety-Compliant Positioner Type		PCON-CG-20PI-NP-2-0					—	
Pulse Train Input Type (Differential Line Driver)		PCON-PL-20PI-NP-2-0	Pulse train input type with differential line driver support	(-)	DC24V	2A Max.	—	→ P525
Pulse Train Input Type (Open Collector)		PCON-PO-20PI-NP-2-0	Pulse train input type with open collector support				—	
Serial Communication Type		PCON-SE-20PI-N-0-0	Dedicated to serial communication	64 points			—	
Field Network Type		RPCON-20P	Dedicated to field network	768 points			—	→ P503
Program Control Type		PSEL-C-1-20PI-NP-2-0	Programmed operation is possible. Can operate up to 2 axes	1500 points			—	→ P557

* This is for the single-axis PSEL.
 * ① is a placeholder for the power supply voltage (1: 100V / 2: 100~240V).

RCP3-SA3C

ROBO Cylinder Slider Type 32mm Width Pulse Motor Coupled

■ Configuration: **RCP3** — **SA3C** — **I** — **28P** — [] — [] — [] — [] — []

Series — Type — Encoder — Motor — Lead — Stroke — Compatible Controllers — Cable Length — Option

I: Incremental 28P: Pulse motor
 * The Simple absolute encoder models are labeled as "I".

28 □ size

6: 6mm 50: 50mm
 4: 4mm 300: 300mm (50mm pitch increments)
 2: 2mm

P1: PCON RPCON PSEL P3: PMEC PSEP

N: None P: 1m S: 3m M: 5m X □ □: Custom Length

See Options below

* See page Pre-35 for explanation of each code that make up the configuration name.

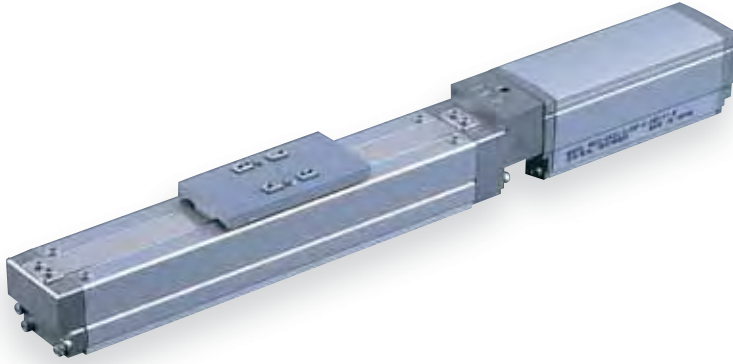

Technical References A-5



- (1) Since the RCP3 series use a pulse motor, the load capacity decreases at high speeds. Check in the Speed vs. Load Capacity graph to see if your desired speed and load capacity are supported.
- (2) The load capacity is based on operation at an acceleration of 0.3G (0.2G for 2mm-lead model, or when used vertically). These values are the upper limits for the acceleration.

■ Speed vs. Load Capacity
 Due to the characteristics of the pulse motor, the RCP3 series' load capacity decreases at high speeds. In the table below, check if your desired speed and load capacity are supported.

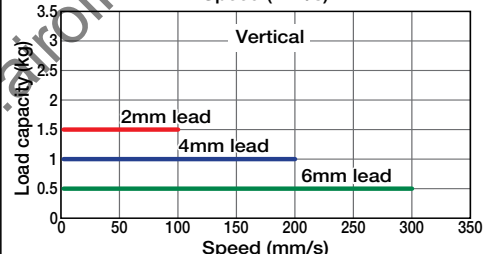
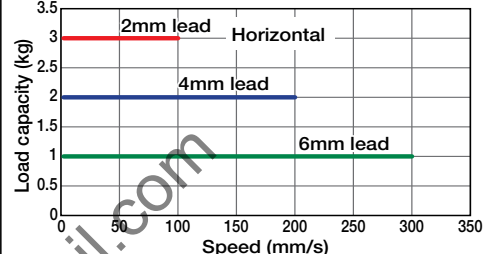

Actuator Specifications					Stroke and Maximum Speed		
■ Lead and Load Capacity					50 ~ 300 (50mm increments)		
Model	Lead (mm)	Max. Load Capacity		Maximum Push Force (N)	Stroke (mm)	Lead	
		Horizontal (kg)	Vertical (kg)				
RCP3-SA3C-I-28P-6-①-②-③-④	6	1	0.5	15	50~300 (50mm increments)	6	300
RCP3-SA3C-I-28P-4-①-②-③-④	4	2	1	22		4	200
RCP3-SA3C-I-28P-2-①-②-③-④	2	3	1.5	44		2	100

Legend ① Stroke ② Compatible controller ③ Cable length ④ Options (Unit: mm/s)

① Stroke List

Stroke (mm)	Standard Price	
	With cover (standard)	No cover (Option)
50	-	-
100	-	-
150	-	-
200	-	-
250	-	-
300	-	-

③ Cable List

Type	Cable Symbol	Standard Price
Standard (Robot Cables)	P (1m)	-
	S (3m)	-
	M (5m)	-
Special Lengths	X06 (6m) ~ X10 (10m)	-
	X11 (11m) ~ X15 (15m)	-
	X16 (16m) ~ X20 (20m)	-

* The standard cable is the motor-encoder integrated robot cable.
 * See page A-39 for cables for maintenance.

④ Option List

Name	Option Code	See Page	Standard Price
Brake-Equipped	B	→ A-25	-
Cable Exit Direction (Top)	CJT	→ A-25	-
Cable Exit Direction (Right)	CJR	→ A-25	-
Cable Exit Direction (Left)	CJL	→ A-25	-
Cable Exit Direction (Bottom)	CJB	→ A-25	-
No Cover	NCO	→ A-33	-
Reversed-home	NM	→ A-33	-

Actuator Specifications

Item	Description
Drive System	Ball screw Ø6mm C10 grade
Positioning Repeatability	±0.02mm
Lost Motion	0.1mm or less
Base	Material: Aluminum (special alumite treated)
Allowable Static Moment	Ma: 5.0N·m Mb: 7.1N·m Mc: 7.9 N·m
Allowable Dynamic Moment(*)	Ma: 1.96N·m Mb: 2.84N·m Mc: 3.14N·m
Overhang Load Length	100mm or less
Ambient Operating Temp./Humidity	0~40°C, 85% RH or less (non-condensing)

(*) Based on 5,000km travel life.

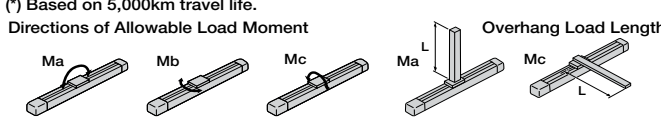

Dimensions

CAD drawings can be downloaded from IAI website. www.intelligentactuator.com



For Special Order P. A-9

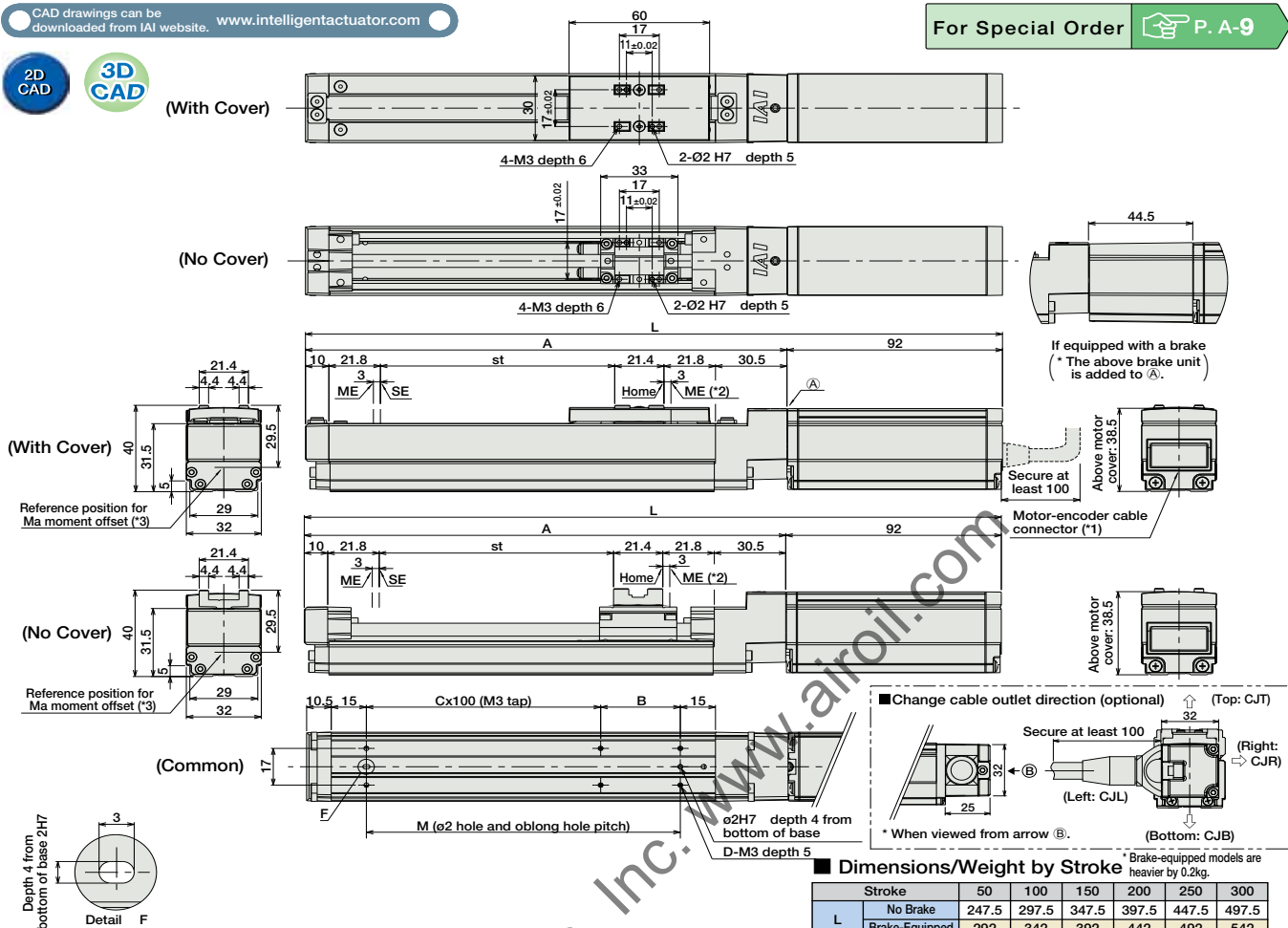

■ Dimensions/Weight by Stroke

Stroke	* Brake-equipped models are heavier by 0.2kg.						
	50	100	150	200	250	300	
L	No Brake	247.5	297.5	347.5	397.5	447.5	497.5
	Brake-Equipped	292	342	392	442	492	542
A	155.5	205.5	255.5	305.5	355.5	405.5	
B	84	34	84	34	84	34	
C	0	1	1	2	2	3	
D	4	6	6	8	8	10	
M	84	134	184	234	284	334	
Weight (kg)	With Cover	0.7	0.7	0.8	0.9	0.9	1
	No Cover	0.6	0.7	0.7	0.8	0.8	0.9

(*1) A Motor-encoder cable (integrated) is connected here. (See page A-39 for details on cables.)
 (*2) After homing, the slider moves to the ME, therefore, please watch for any interference with surrounding objects.
 ME : Mechanical end
 SE : Stroke end
 (*3) Reference position for calculating the moment Ma

② Compatible Controllers

The RCP3 series actuators can operate with the controllers below. Select the controller according to your usage.

Name	External View	Model	Description	Max. Positioning Points	Input Voltage	Power Supply Capacity	Standard Price	See Page
Solenoid Valve Type		PMEC-C-28PI-NP-2-①	Easy-to-use controller, even for beginners	3 points	AC100V AC200V	See P481	-	→ P477
		PSEP-C-28PI-NP-2-0	Operable with same signal as solenoid valve. Supports both single and double solenoid types. No homing necessary with simple absolute type.					
Splash-Proof Solenoid Valve Type		PSEP-CW-28PI-NP-2-0						
Positioner Type		PCON-C-28PI-NP-2-0	Positioning is possible for up to 512 points	512 points	DC24V	2A Max.	-	→ P525
Safety-Compliant Positioner Type		PCON-CG-28PI-NP-2-0						
Pulse Train Input Type (Differential Line Driver)		PCON-PL-28PI-NP-2-0	Pulse train input type with differential line driver support	(-)	DC24V	2A Max.	-	→ P525
Pulse Train Input Type (Open Collector)		PCON-PO-28PI-NP-2-0	Pulse train input type with open collector support					
Serial Communication Type		PCON-SE-28PI-N-0-0	Dedicated to serial communication	64 points				
Field Network Type		RPCON-28P	Dedicated to field network	768 points				→ P503
Program Control Type		PSEL-C-1-28PI-NP-2-0	Programmed operation is possible. Can operate up to 2 axes	1500 points				→ P557

* This is for the single-axis PSEL.
 * ① is a placeholder for the power supply voltage (1: 100V / 2: 100~240V).

- Slider Type
- Mini
- Standard
- Controllers Integrated
- Rod Type
- Mini
- Standard
- Controllers Integrated
- Table/Arm/Flat Type
- Mini
- Standard
- Gripper/Rotary Type
- Linear Servo Type
- Cleanroom Type
- Splash-Proof
- Controllers
- PMEC/AMEC
- PSEP/ASEP
- ROBO NET
- ERC2
- PCON
- ACON
- SCON
- PSEL
- ASEL
- SSEL
- XSEL
- Pulse Motor
- Servo Motor (24V)
- Servo Motor (200V)
- Linear Servo Motor

RCP3-SA4C

ROBO Cylinder Slider Type 40mm Width Pulse Motor Coupled

■ Configuration: **RCP3** — **SA4C** — **I** — **35P** — [] — [] — [] — [] — []

Series — Type — Encoder — Motor — Lead — Stroke — Compatible Controllers — Cable Length — Option

I: Incremental 35P: Pulse motor 10: 10mm 50: 50mm P1: PCON N: None See Options below
 * The Simple absolute encoder models are labeled as "I". 35 □ size 5: 5mm 500: 500mm (50mm pitch increments) P2: RPCON P: 1m PSEL S: 3m M: 5m X □ □ : Custom Length
 P3: PMEC PSEP

* See page Pre-35 for explanation of each code that make up the configuration name.

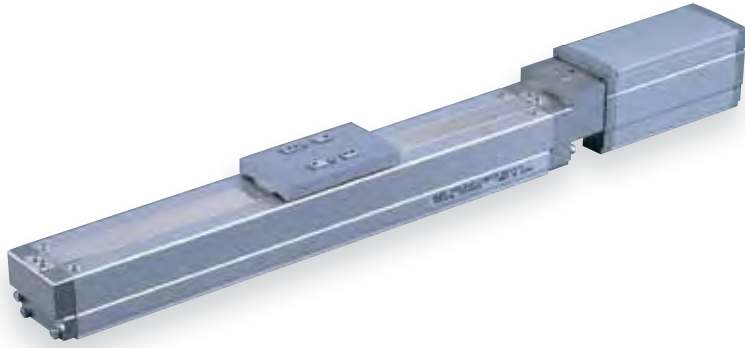

Technical References A-5



- (1) Since the RCP3 series use a pulse motor, a load capacity decreases at high speeds. Check in the Speed vs. Load Capacity graph to see if your desired speed and load capacity are supported.
- (2) The load capacity is based on operation at an acceleration of 0.3G (0.2G for 2.5 mm-lead model, or when used vertically). The maximum acceleration is 0.7G (0.3G when used vertically), however, note that the load capacity decreases at high accelerations. For more information, see the table of load capacity by acceleration, on page A-50.

■ Speed vs. Load Capacity
 Due to the characteristics of the pulse motor, the RCP3 series' load capacity decreases at high speeds. In the table below, check if your desired speed and load capacity are supported.

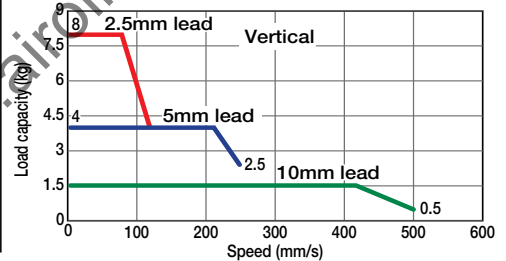
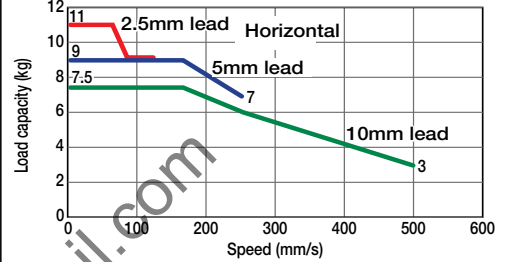

Actuator Specifications

■ Lead and Load Capacity

Model	Lead (mm)	Max. Load Capacity		Maximum Push Force (N)	Stroke (mm)
		Horizontal (kg)	Vertical (kg)		
RCP3-SA4C-I-35P-10-①-②-③-④	10	~ 7.5	~ 1.5	34	50~500 (50mm increments)
RCP3-SA4C-I-35P-5-①-②-③-④	5	~ 9	~ 4	68	
RCP3-SA4C-I-35P-2.5-①-②-③-④	2.5	~ 11	~ 8	136	

■ Stroke and Maximum Speed

Stroke / Lead	50 ~ 500 (50mm increments)	
	Stroke	Maximum Speed
10	500	
5	250	
2.5	125	

(Unit: mm/s)

Legend ① Stroke ② Compatible controller ③ Cable length ④ Options

① Stroke List

Stroke (mm)	Standard Price	
	With cover (standard)	No cover (Option)
50	-	-
100	-	-
150	-	-
200	-	-
250	-	-
300	-	-
350	-	-
400	-	-
450	-	-
500	-	-

③ Cable List

Type	Cable Symbol	Standard Price
Standard (Robot Cables)	P (1m)	-
	S (3m)	-
	M (5m)	-
Special Lengths	X06 (6m) ~ X10 (10m)	-
	X11 (11m) ~ X15 (15m)	-
	X16 (16m) ~ X20 (20m)	-

* See page A-39 for cables for maintenance.

④ Option List

Name	Option Code	See Page	Standard Price
Brake-Equipped	B	→ A-25	-
Cable Exit Direction (Top)	CJT	→ A-25	-
Cable Exit Direction (Right)	CJR	→ A-25	-
Cable Exit Direction (Left)	CJL	→ A-25	-
Cable Exit Direction (Bottom)	CJB	→ A-25	-
No Cover	NCO	→ A-33	-
Reversed-home	NM	→ A-33	-

Actuator Specifications

Item	Description
Drive System	Ball screw Ø8mm C10 grade
Positioning Repeatability	±0.02mm
Lost Motion	0.1mm or less
Base	Material: Aluminum (special alumite treated)
Allowable Static Moment	Ma: 6.8N·m Mb: 9.7N·m Mc: 13.3 N·m
Allowable Dynamic Moment(*)	Ma: 3.04N·m Mb: 4.31N·m Mc: 5.00N·m
Overhang Load Length	120mm or less
Ambient Operating Temp./Humidity	0~40°C, 85%RH or less (Non-condensing)

(*) Based on 5,000km travel life.

Directions of Allowable Load Moment

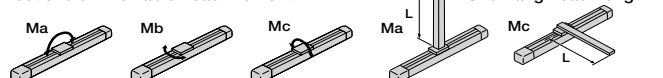

Dimensions

CAD drawings can be downloaded from IAI website. www.intelligentactuator.com

For Special Order P. A-9

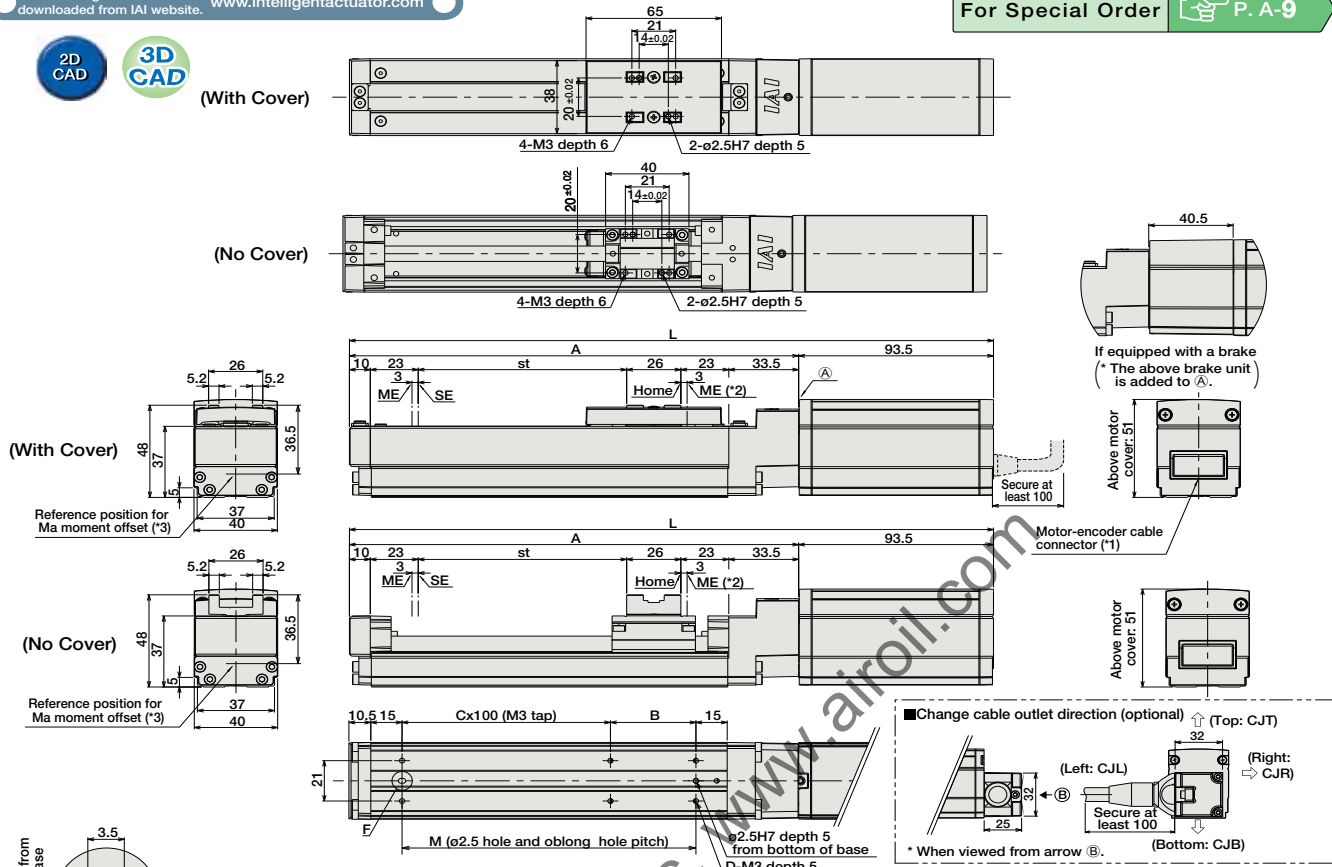

■ Dimensions/Weight by Stroke

* Brake-equipped models are heavier by 0.3kg.

Stroke	50	100	150	200	250	300	350	400	450	500	
No Brake	259	309	359	409	459	509	559	609	659	709	
Brake-Equipped	299.5	349.5	399.5	449.5	499.5	549.5	599.5	649.5	699.5	749.5	
A	165.5	215.5	265.5	315.5	365.5	415.5	465.5	515.5	565.5	615.5	
B	91	41	91	41	91	41	91	41	91	41	
C	0	1	1	2	2	3	3	4	4	5	
D	4	6	6	8	8	10	10	12	12	14	
M	91	141	191	241	291	341	391	441	491	541	
Weight (kg)	With Cover	0.9	1	1.1	1.2	1.3	1.4	1.5	1.6	1.7	1.8
	No Cover	0.9	0.9	1	1.1	1.2	1.2	1.3	1.4	1.5	1.5

- (*1) A Motor-encoder cable (integrated) is connected here. (See page A-39 for details on cables.)
- (*2) After homing, the slider moves to the ME, therefore, please watch for any interference with surrounding objects.
ME : Mechanical end
SE : Stroke end
- (*3) Reference position for calculating the moment Ma.

② Compatible Controllers

The RCP3 series actuators can operate with the controllers below. Select the controller according to your usage.

Name	External View	Model	Description	Max. Positioning Points	Input Voltage	Power Supply Capacity	Standard Price	See Page
Solenoid Valve Type		PMEC-C-35PI-NP-2-①	Easy-to-use controller, even for beginners	3 points	AC100V AC200V	See P481	-	→ P477
		PSEP-C-35PI-NP-2-0-H	Operable with same signal as solenoid valve. Supports both single and double solenoid types. No homing necessary with simple absolute type.					
Splash-Proof Solenoid Valve Type		PSEP-CW-35PI-NP-2-0-H						→ P487
Positioner Type		PCON-C-35PI-NP-2-0-H	Positioning is possible for up to 512 points	512 points				
Safety-Compliant Positioner Type		PCON-CG-35PI-NP-2-0-H						
Pulse Train Input Type (Differential Line Driver)		PCON-PL-35PI-NP-2-0-H	Pulse train input type with differential line driver support	(-)	DC24V	2A Max.		→ P525
Pulse Train Input Type (Open Collector)		PCON-PO-35PI-NP-2-0-H						
Serial Communication Type		PCON-SE-35PI-N-0-0-H	Dedicated to serial communication	64 points				
Field Network Type		RPCON-35P-H	Dedicated to field network	768 points				→ P503
Program Control Type		PSEL-C-1-35PI-NP-2-0-H	Programmed operation is possible. Can operate up to 2 axes	1500 points				→ P557

* This is for the single-axis PSEL.
* ① is a placeholder for the power supply voltage (1: 100V / 2: 100~240V).

- Slider Type
- Mini
- Standard
- Controllers Integrated
- Rod Type
- Mini
- Standard
- Controllers Integrated
- Table/Arm/Flat Type
- Mini
- Standard
- Gripper/Rotary Type
- Linear Servo Type
- Cleanroom Type
- Splash-Proof
- Controllers
- PMEC/AMEC
- PSEP/ASEP
- ROBO NET
- ERC2
- PCON
- ACON
- SCON
- PSEL
- ASEL
- SSEL
- XSEL
- Pulse Motor
- Servo Motor (24V)
- Servo Motor (200V)
- Linear Servo Motor

RCP3-SA5C

ROBO Cylinder Slider Type 50mm Width Pulse Motor Coupled

■ Configuration: **RCP3** — **SA5C** — **I** — **42P** — [] — [] — [] — [] — []

Series — Type — Encoder — Motor — Lead — Stroke — Compatible Controllers — Cable Length — Option

I: Incremental
* The Simple absolute encoder models are labeled as "I".

42P: Pulse motor
42 □ size

12 : 12mm
6 : 6mm
3 : 3mm

50: 50mm
800: 800mm (50mm pitch increments)

P1: PCON
RPCON
PSEL
P3: PMEC
PSEP

N : None
P : 1m
S : 3m
M : 5m
X □ □ : Custom Length

See Options below

* See page Pre-35 for explanation of each code that make up the configuration name.

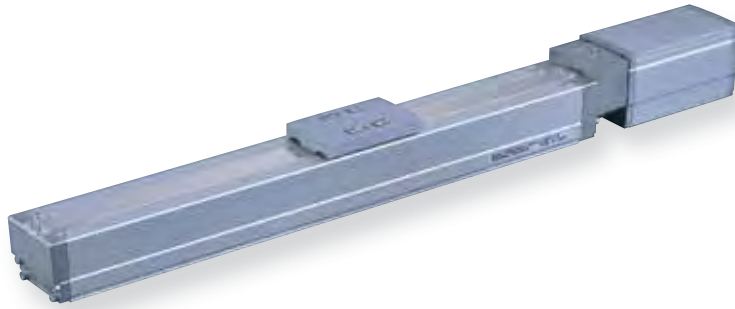

Technical References A-5

- POINT**
Notes on Selection
- Since the RCP3 series use a pulse motor, the load capacity decreases at high speeds. Check in the Speed vs. Load Capacity graph to see if your desired speed and load capacity are supported.
 - The load capacity is based on operation at an acceleration of 0.3G (0.2G for 3mm-lead model, or when used vertically). The maximum acceleration is 0.7G (0.3G when used vertically), however, note that the load capacity decreases at high accelerations. For more information, see the table of load capacity by acceleration, on page A-50.

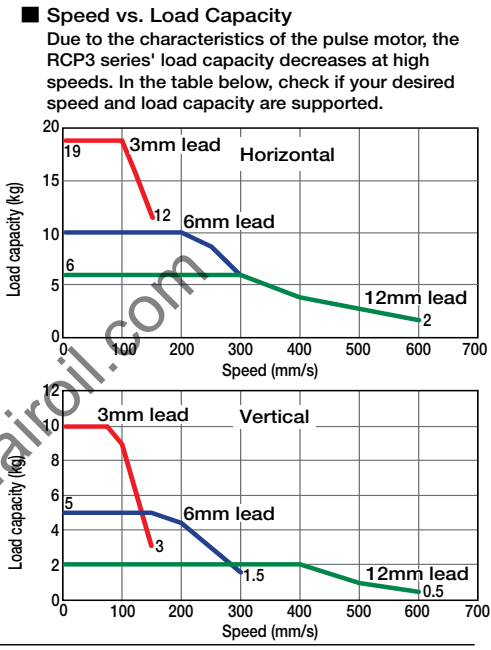

Actuator Specifications

■ Lead and Load Capacity

Model	Lead (mm)	Max. Load Capacity		Maximum Push Force (N)	Stroke (mm)
		Horizontal (kg)	Vertical (kg)		
RCP3-SA5C-I-42P-12-①-②-③-④	12	~ 6	~ 2	47	50~800 (50mm increments)
RCP3-SA5C-I-42P-6-①-②-③-④	6	~ 10	~ 5	95	
RCP3-SA5C-I-42P-3-①-②-③-④	3	~ 19	~ 10	189	

Legend ① Stroke ② Compatible controller ③ Cable length ④ Options

■ Stroke and Maximum Speed

Stroke Lead	50 ~ 550 (50mm increments)	600 (mm)	650 (mm)	700 (mm)	750 (mm)	800 (mm)
12	600	570	490	425	370	330
6	300	285	245	210	185	165
3	150	140	120	105	90	80

(Unit: mm/s)

① Stroke List

Stroke (mm)	Standard Price	
	With cover (standard)	No cover (Option)
50	-	-
100	-	-
150	-	-
200	-	-
250	-	-
300	-	-
350	-	-
400	-	-
450	-	-
500	-	-
550	-	-
600	-	-
650	-	-
700	-	-
750	-	-
800	-	-

③ Cable List

Type	Cable Symbol	Standard Price
Standard (Robot Cables)	P (1m)	-
	S (3m)	-
	M (5m)	-
Special Lengths	X06 (6m) ~ X10 (10m)	-
	X11 (11m) ~ X15 (15m)	-
	X16 (16m) ~ X20 (20m)	-

④ Option List

Name	Option Code	See Page	Standard Price
Brake-Equipped	B	→ A-25	-
Cable Exit Direction (Top)	CJT	→ A-25	-
Cable Exit Direction (Right)	CJR	→ A-25	-
Cable Exit Direction (Left)	CJL	→ A-25	-
Cable Exit Direction (Bottom)	CJB	→ A-25	-
No Cover	NCO	→ A-33	-
Reversed-home	NM	→ A-33	-

Actuator Specifications

Item	Description
Drive System	Ball screw Ø10mm C10 grade
Positioning Repeatability	±0.02mm
Lost Motion	0.1mm or less
Base	Material: Aluminum (special alumite treated)
Allowable Static Moment	Ma: 10.2N·m Mb: 14.6N·m Mc: 22.4N·m
Allowable Dynamic Moment(*)	Ma: 3.92N·m Mb: 5.58N·m Mc: 8.53N·m
Overhang Load Length	130mm or less
Ambient Operating Temp./Humidity	0~40°C, 85% RH or less (non-condensing)

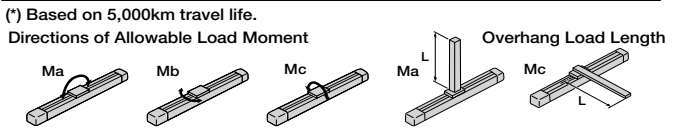

Dimensions

CAD drawings can be downloaded from IAI website. www.intelligentactuator.com



For Special Order P. A-9

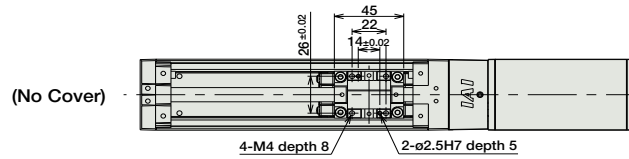
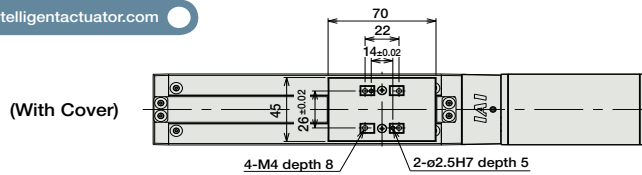

- (*) A motor-encoder cable (integrated) is connected here. (See page A-39 for details on cables.)
- (**) After homing, the slider moves to the ME, therefore, please watch for any interference with surrounding objects.
ME : Mechanical end
SE : Stroke end
- (***) Reference position for calculating the moment Ma

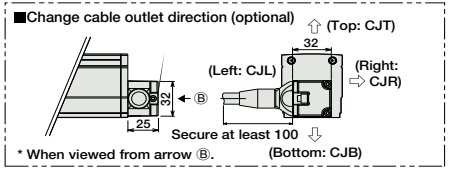
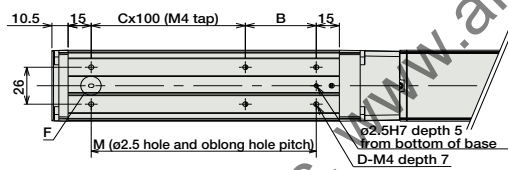
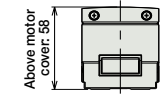
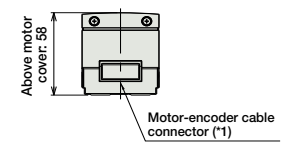
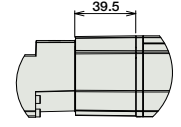
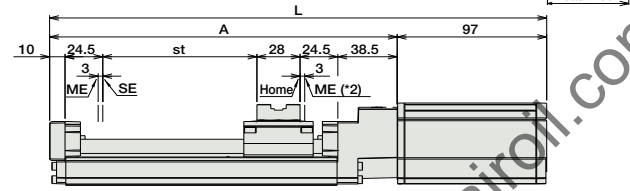
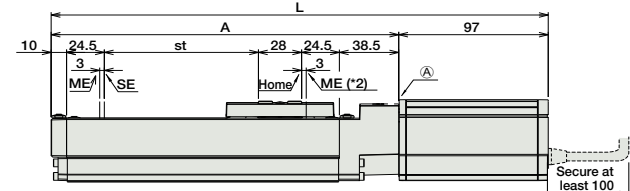
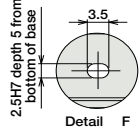
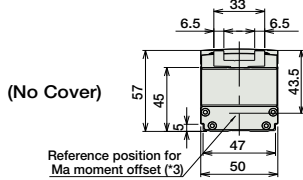
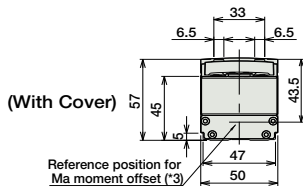

■ Dimensions/Weight by Stroke * Brake-equipped models are heavier by 0.4kg.

L	Stroke	50	100	150	200	250	300	350	400	450	500	550	600	650	700	750	800
	No Brake	272.5	322.5	372.5	422.5	472.5	522.5	572.5	622.5	672.5	722.5	772.5	822.5	872.5	922.5	972.5	1022.5
Brake-Equipped	312	362	412	462	512	562	612	662	712	762	812	862	912	962	1012	1062	
A	175.5	225.5	275.5	325.5	375.5	425.5	475.5	525.5	575.5	625.5	675.5	725.5	775.5	825.5	875.5	925.5	
B	96	46	96	46	96	46	96	46	96	46	96	46	96	46	96	46	
C	0	1	1	2	2	3	3	4	4	5	5	6	6	7	7	8	
D	4	6	6	8	8	10	10	12	12	14	14	16	16	18	18	20	
M	96	146	196	246	296	346	396	446	496	546	596	646	696	746	796	846	
Weight (kg)	With Cover	1.4	1.5	1.6	1.8	1.9	2	2.2	2.3	2.5	2.6	2.7	2.9	3.0	3.2	3.3	3.4
	No Cover	1.3	1.4	1.5	1.6	1.7	1.8	2	2.1	2.2	2.3	2.4	2.5	2.6	2.8	2.9	3.0

② Compatible Controllers

The RCP3 series actuators can operate with the controllers below. Select the controller according to your usage.

Name	External View	Model	Description	Max. Positioning Points	Input Voltage	Power Supply Capacity	Standard Price	See Page
Solenoid Valve Type		PMEC-C-42PI-NP-2-①	Easy-to-use controller, even for beginners	3 points	AC100V AC200V	See P481	-	→ P477
		PSEP-C-42PI-NP-2-0-H	Operable with same signal as solenoid valve. Supports both single and double solenoid types. No homing necessary with simple absolute type.					
Splash-Proof Solenoid Valve Type		PSEP-CW-42PI-NP-2-0-H						→ P487
Positioner Type		PCON-C-42PI-NP-2-0-H	Positioning is possible for up to 512 points	512 points	DC24V	2A Max.	-	→ P525
Safety-Compliant Positioner Type		PCON-CG-42PI-NP-2-0-H						
Pulse Train Input Type (Differential Line Driver)		PCON-PL-42PI-NP-2-0-H	Pulse train input type with differential line driver support	(-)	DC24V	2A Max.	-	→ P525
Pulse Train Input Type (Open Collector)		PCON-PO-42PI-NP-2-0-H	Pulse train input type with open collector support					
Serial Communication Type		PCON-SE-42PI-N-0-0-H	Dedicated to serial communication	64 points				
Field Network Type		RPCON-42P-H	Dedicated to field network	768 points				→ P503
Program Control Type		PSEL-C-1-42PI-NP-2-0-H	Programmed operation is possible. Can operate up to 2 axes	1500 points				→ P557

* This is for the single-axis PSEL.

* ① is a placeholder for the power supply voltage (1: 100V / 2: 100~240V).

RCP3-SA6C

ROBO Cylinder Slider Type 60mm Width Pulse Motor Coupled

■ Configuration: **RCP3** — **SA6C** — **I** — **42P** — [] — [] — [] — [] — []

Series — Type — Encoder — Motor — Lead — Stroke — Compatible Controllers — Cable Length — Option

I: Incremental
* The Simple absolute encoder models are labeled as "I".

42P: Pulse motor
42 □ size

12 : 12mm
6 : 6mm
3 : 3mm

50: 50mm
50mm
800: 800mm
(50mm pitch increments)

P1: PCON
RPCON
PSEL
P3: PMEC
PSEP

N : None
P : 1m
S : 3m
M : 5m
X □ □ : Custom Length

See Options below

* See page Pre-35 for explanation of each code that make up the configuration name.

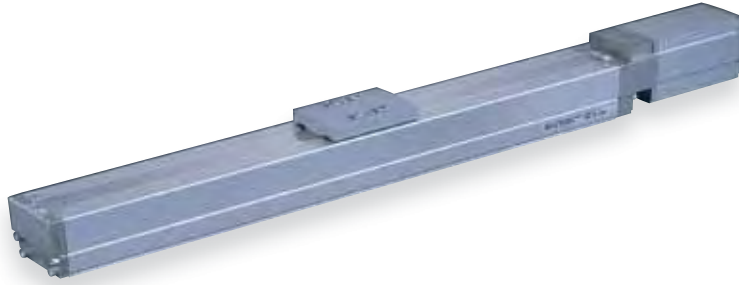

Technical References A-5

- POINT** Notes on Selection
- When the stroke increases, the maximum speed will drop to prevent the ball screw from reaching the critical rotational speed. Use the actuator specification table below to check the maximum speed at the stroke you desire.
 - Since the RCP3 series use a pulse motor, the load capacity decreases at high speeds. Check in the Speed vs. Load Capacity graph to see if your desired speed and load capacity are supported.
 - The load capacity is based on operation at an acceleration of 0.3G (0.2G for 3mm lead model and when used vertically). The maximum acceleration is 0.7G (0.3G when used vertically), however, note that the load capacity decreases at high accelerations. For more information, see the table of load capacity by acceleration, on page A-50.

■ Speed vs. Load Capacity
Due to the characteristics of the pulse motor, the RCP3 series' load capacity decreases at high speeds. In the table below, check if your desired speed and load capacity are supported.

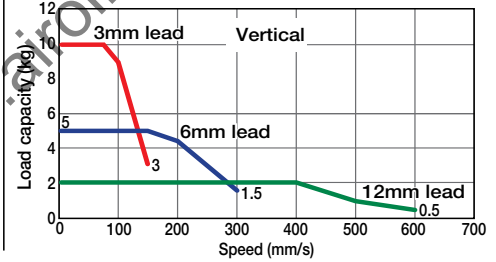
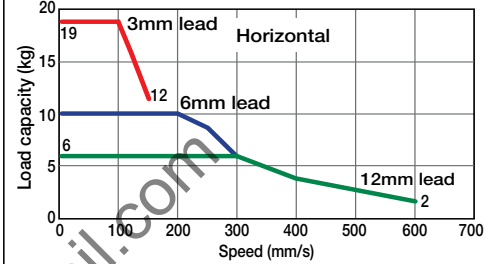

Actuator Specifications

Lead and Load Capacity

Model	Lead (mm)	Max. Load Capacity		Maximum Push Force (N)	Stroke (mm)
		Horizontal (kg)	Vertical (kg)		
RCP3-SA6C-I-42P-12-①-②-③-④	12	~ 6	~ 2	47	50~800 (50mm increments)
RCP3-SA6C-I-42P-6-①-②-③-④	6	~ 10	~ 5	95	
RCP3-SA6C-I-42P-3-①-②-③-④	3	~ 19	~ 10	189	

Legend ① Stroke ② Compatible controller ③ Cable length ④ Options

Stroke and Maximum Speed

Stroke Lead	50 ~ 550	600	650	700	750	800
	(50mm increments)	(mm)	(mm)	(mm)	(mm)	(mm)
12	600	570	490	425	370	330
6	300	285	245	210	185	165
3	150	140	120	105	90	80

(Unit: mm/s)

① Stroke List

Stroke (mm)	Standard Price	
	With cover (standard)	No cover (Option)
50	-	-
100	-	-
150	-	-
200	-	-
250	-	-
300	-	-
350	-	-
400	-	-
450	-	-
500	-	-
550	-	-
600	-	-
650	-	-
700	-	-
750	-	-
800	-	-

④ Option List

Name	Option Code	See Page	Standard Price
Brake-Equipped	B	→ A-25	-
Cable Exit Direction (Top)	CJT	→ A-25	-
Cable Exit Direction (Right)	CJR	→ A-25	-
Cable Exit Direction (Left)	CJL	→ A-25	-
Cable Exit Direction (Bottom)	CJB	→ A-25	-
No Cover	NCO	→ A-33	-
Reversed-home	NM	→ A-33	-

③ Cable List

Type	Cable Symbol	Standard Price
Standard (Robot Cables)	P (1m)	-
	S (3m)	-
	M (5m)	-
Special Lengths	X06 (6m) ~ X10 (10m)	-
	X11 (11m) ~ X15 (15m)	-
	X16 (16m) ~ X20 (20m)	-
		-

* See page A-39 for cables for maintenance.

Actuator Specifications

Item	Description
Drive System	Ball screw Ø10mm C10 grade
Positioning Repeatability	±0.02mm
Lost Motion	0.1mm or less
Base	Material: Aluminum (special alumite treated)
Allowable Static Moment	Ma: 17.6N·m Mb: 25.2N·m Mc: 44.5N·m
Allowable Dynamic Moment(*)	Ma: 4.31N·m Mb: 6.17N·m Mc: 10.98N·m
Overhang Load Length	150mm or less
Ambient Operating Temp./Humidity	0 ~ 40°C, 85% RH or less (non-condensing)

(*) Based on 5,000km travel life.

Directions of Allowable Load Moment

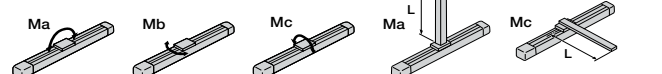

Dimensions

CAD drawings can be downloaded from IAI website. www.intelligentactuator.com



For Special Order P. A-9

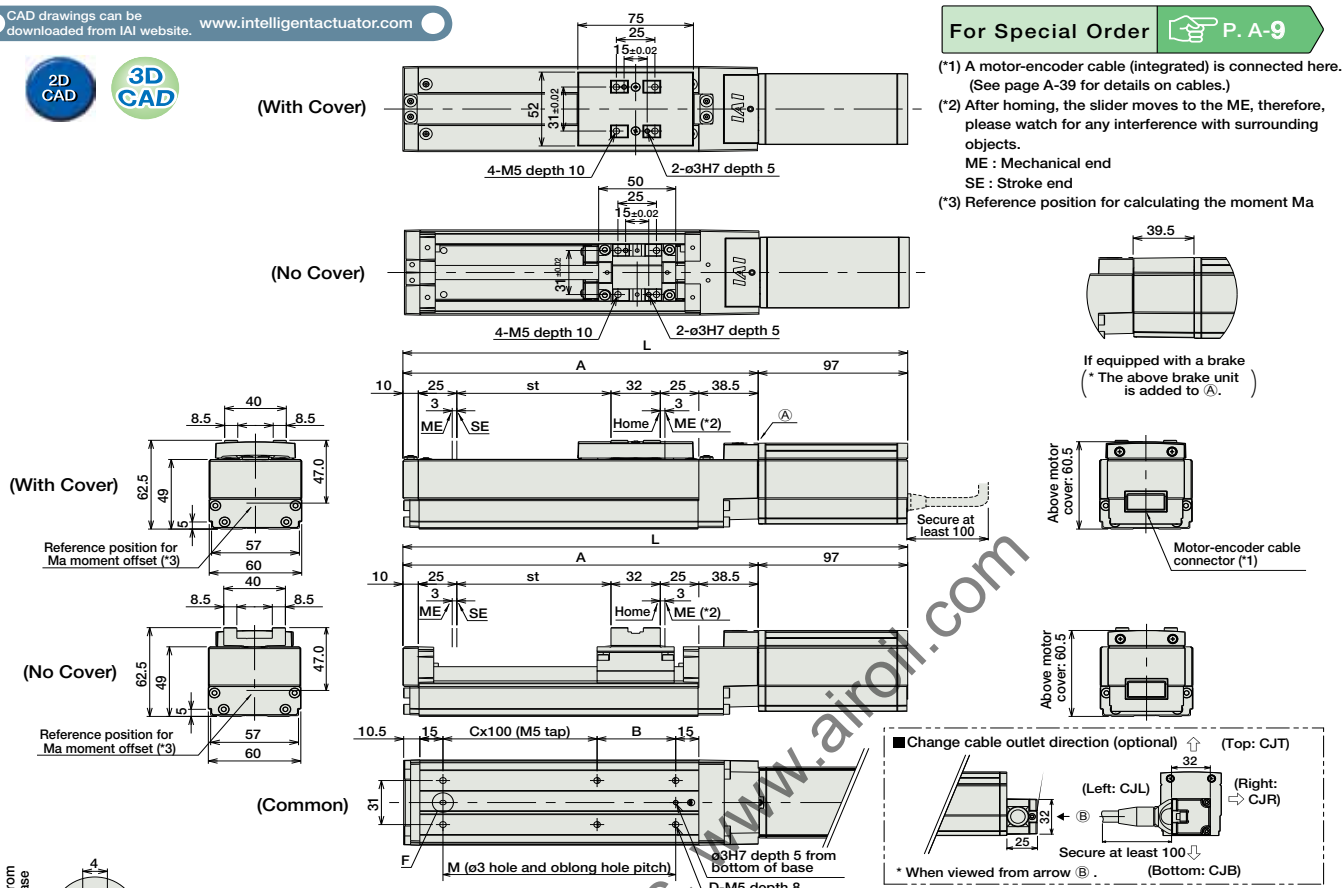

■ Dimensions/Weight by Stroke * Brake equipped models are heavier by 0.4kg.

Stroke	50	100	150	200	250	300	350	400	450	500	550	600	650	700	750	800	
L	No Brake	277.5	327.5	377.5	427.5	477.5	527.5	577.5	627.5	677.5	727.5	777.5	827.5	877.5	927.5	977.5	1027.5
	Brake-Equipped	317	367	417	467	517	567	617	667	717	767	817	867	917	967	1017	1067
A	180.5	230.5	280.5	330.5	380.5	430.5	480.5	530.5	580.5	630.5	680.5	730.5	780.5	830.5	880.5	930.5	
B	101	51	101	51	101	51	101	51	101	51	101	51	101	51	101	51	
C	0	1	1	2	2	3	3	4	4	5	5	6	6	7	7	8	
D	4	6	6	8	8	10	10	12	12	14	14	16	16	18	18	20	
M	101	151	201	251	301	351	401	451	501	551	601	651	701	751	801	851	
Weight (kg)	With Cover	1.6	1.8	2	2.1	2.3	2.5	2.7	2.8	3	3.2	3.3	3.5	3.7	3.9	4.0	4.2
	No Cover	1.5	1.7	1.8	2	2.1	2.3	2.4	2.6	2.7	2.8	3	3.1	3.3	3.4	3.6	3.7

② Compatible Controllers

The RCP3 series actuators can operate with the controllers below. Select the controller according to your usage.

Name	External View	Model	Description	Max. Positioning Points	Input Voltage	Power Supply Capacity	Standard Price	See Page
Solenoid Valve Type		PMEC-C-42PI-NP-2-0-①	Easy-to-use controller, even for beginners	3 points	AC100V AC200V	See P481	-	→ P477
		PSEP-C-42PI-NP-2-0-H	Operable with same signal as solenoid valve. Supports both single and double solenoid types. No homing necessary with simple absolute type.					
Splash-Proof Solenoid Valve Type		PSEP-CW-42PI-NP-2-0-H						
Positioner Type		PCON-C-42PI-NP-2-0-H	Positioning is possible for up to 512 points	512 points	DC24V	2A Max.	-	→ P525
Safety-Compliant Positioner Type		PCON-CG-42PI-NP-2-0-H						
Pulse Train Input Type (Differential Line Driver)		PCON-PL-42PI-NP-2-0-H	Pulse train input type with differential line driver support	(-)	DC24V	2A Max.	-	→ P525
Pulse Train Input Type (Open Collector)		PCON-PO-42PI-NP-2-0-H	Pulse train input type with open collector support					
Serial Communication Type		PCON-SE-42PI-N-0-0-H	Dedicated to serial communication	64 points				
Field Network Type		RPCON-42P-H	Dedicated to field network	768 points				→ P503
Program Control Type		PSEL-C-1-42PI-NP-2-0-H	Programmed operation is possible. Can operate up to 2 axes	1500 points				→ P557

* This is for the single-axis PSEL.

* ① is a placeholder for the power supply voltage (1: 100V / 2: 100~240V).

- Slider Type
- Mini
- Standard
- Controllers Integrated
- Rod Type
- Mini
- Standard
- Controllers Integrated
- Table/Arm/Flat Type
- Mini
- Standard
- Gripper/Rotary Type
- Linear Servo Type
- Cleanroom Type
- Splash-Proof
- Controllers
- PMEC /AMEC
- PSEP /ASEP
- ROBO NET
- ERC2
- PCON
- ACON
- SCON
- PSEL
- ASEL
- SSEL
- XSEL
- Pulse Motor
- Servo Motor (24V)
- Servo Motor (200V)
- Linear Servo Motor

RCP3-SA2AR

ROBO Cylinder Mini Slider Type Side-Mounted Motor Unit 22mm Width
Pulse Motor Lead Screw

■ Configuration: **RCP3** — **SA2AR** — **I** — **20P** — — — — —

Series	Type	Encoder	Motor	Lead	Stroke	Compatible Controllers	Cable Length	Option
I: Incremental * The Simple absolute encoder models are labeled as "I".	20P: Pulse motor 20 □ size	4S : 4mm lead screw 2S : 2mm lead screw 1S : 1mm lead screw	25: 25mm 100: 100mm (25mm pitch increments)	P1: PCON RPCON PSEL P3: PMEC PSEP	N : None P : 1m S : 3m M : 5m X □ □ : Custom Length	See Options below * Be sure to specify which side the motor is to be mounted (ML/MR).		

* See page Pre-35 for explanation of each code that make up the configuration name.

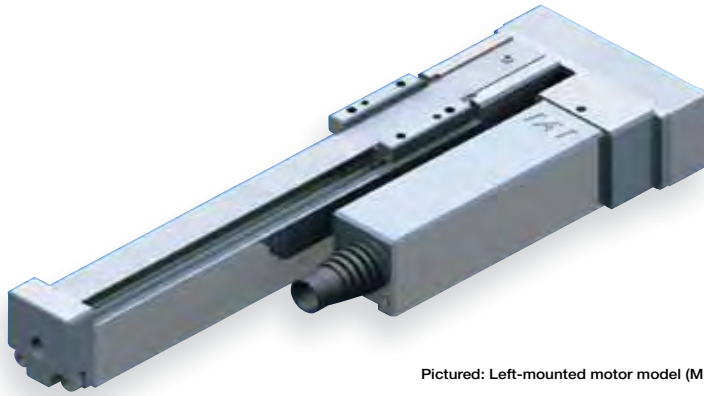

Pictured: Left-mounted motor model (ML).

Technical References A-5

■ Speed vs. Load Capacity
Due to the characteristics of the pulse motor, the RCP3 series' load capacity decreases at high speeds. In the table below, check if your desired speed and load capacity are supported.

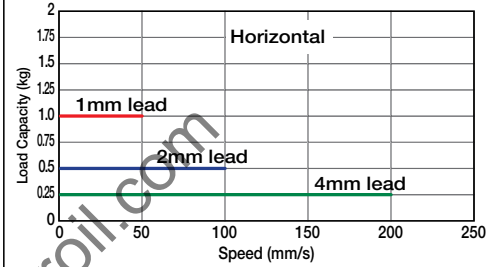

- POINT**
Notes on Selection
- (1) The load capacity is based on operation at an acceleration of 0.2G. This is the upper limit for the acceleration.
 - (2) The actuator cannot be used on its side or in a vertical orientation.
 - (3) If used in a dusty environment, the service life will decrease significantly.
 - (4) This model uses a lead screw, therefore please ensure that your usage is appropriate for its characteristics. (See page Pre-42.)

Actuator Specifications						
■ Lead and Load Capacity				■ Stroke and Maximum Speed		
Model	Feed Screw	Lead (mm)	Max. Load Capacity		Positioning Repeatability (mm)	Stroke (mm)
			Horizontal (kg)	Vertical (kg)		
RCP3-SA2AR-I-20P-4S-①-②-③-④	4	4	0.25	-	±0.05	25~100 (25mm increments)
RCP3-SA2AR-I-20P-2S-①-②-③-④	2	2	0.5	-		
RCP3-SA2AR-I-20P-1S-①-②-③-④	1	1	1	-		

Lead	Stroke	
	25 (mm)	50 ~ 100 (mm)
Lead screw	4	200
	2	100
	1	50

Legend ① Stroke ② Compatible controller ③ Cable length ④ Options (Unit: mm/s)

① Stroke List

Stroke (mm)	Standard Price
25	-
50	-
75	-
100	-

③ Cable List

Type	Cable Symbol	Standard Price
Standard (Robot Cables)	P (1m)	-
	S (3m)	-
	M (5m)	-
Special Lengths	X06 (6m) ~ X10 (10m)	-
	X11 (11m) ~ X15 (15m)	-
	X16 (16m) ~ X20 (20m)	-
		-

* The standard cable for the RCP3 is the robot cable.
* See page A-39 for cables for maintenance.

④ Option List

Name	Option Code	See Page	Standard Price
Left-mounted motor (Standard)	ML	→ A-33	-
Right-mounted motor	MR	→ A-33	-
Reversed-home	NM	→ A-33	-

Actuator Specifications

Item	Description
Drive System	Lead screw Ø4mm C10 grade
Lost Motion	0.3mm or less (initial value)
Base	Material: Aluminum (white alumite treated)
Guide	Slide guide
Ambient Operating Temp./Humidity	0~40°C, 85% RH or less (non-condensing)
Service Life	10 million cycles

Dimensions

CAD drawings can be downloaded from IAI website. www.intelligentactuator.com

For Special Orders A-9



- *1 A motor-encoder cable is connected here. See page A-39 for details on cables.
- *2 During the homing operation, the slider moves to actuator's mechanical end; therefore, please watch for any interference with the surrounding objects.

* The diagram below shows a left-mounted motor model.

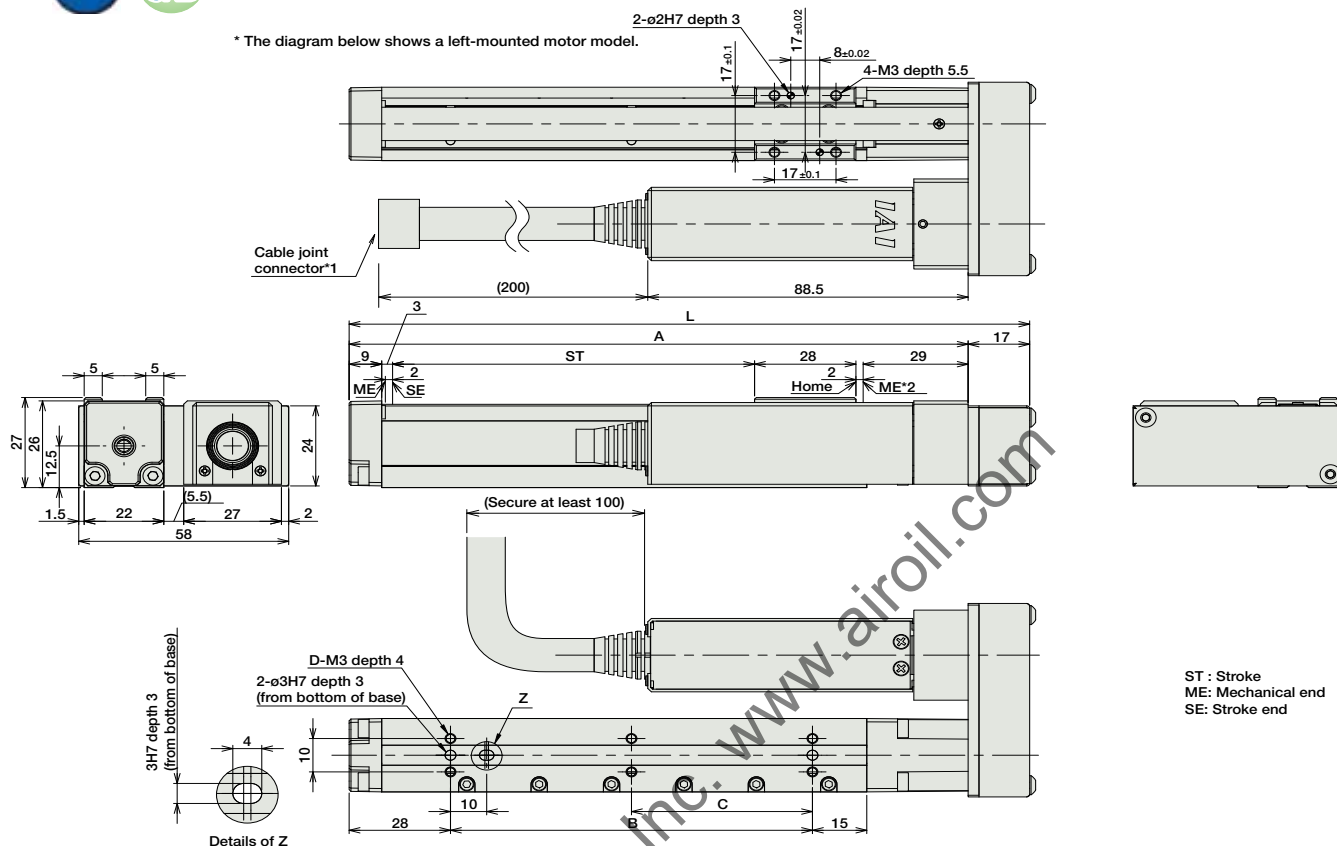

ST : Stroke
ME : Mechanical end
SE : Stroke end

Dimensions/Weight by Stroke

Stroke	25	50	75	100
L	113	138	163	188
A	96	121	146	171
B	25	50	75	100
C	0	0	0	50
D	4	4	4	6
Weight (kg)	0.28	0.3	0.32	0.33

② Compatible Controllers

The RCP3 series actuators can operate with the controllers below. Select the controller according to your usage.

Name	External View	Model	Description	Max. Positioning Points	Input Voltage	Power Supply Capacity	Standard Price	See Page
Solenoid Valve Type		PMEC-C-20PI-NP-2-①	Easy-to-use controller, even for beginners	3 points	AC100V AC200V	See P481	-	→ P477
		PSEP-C-20PI-NP-2-0	Operable with same signal as solenoid valve. Supports both single and double solenoid types. No homing necessary with simple absolute type.					
Splash-Proof Solenoid Valve Type		PSEP-CW-20PI-NP-2-0						
Positioner Type		PCON-C-20PI-NP-2-0	Positioning is possible for up to 512 points	512 points	DC24V	2A Max.	-	→ P525
Safety-Compliant Positioner Type		PCON-CG-20PI-NP-2-0						
Pulse Train Input Type (Differential Line Driver)		PCON-PL-20PI-NP-2-0	Pulse train input type with differential line driver support	(-)	DC24V	2A Max.	-	→ P525
Pulse Train Input Type (Open Collector)		PCON-PO-20PI-NP-2-0	Pulse train input type with open collector support					
Serial Communication Type		PCON-SE-20PI-N-0-0	Dedicated to serial communication	64 points				
Field Network Type		RPCON-20P	Dedicated to field network	768 points				→ P503
Program Control Type		PSEL-C-1-20PI-NP-2-0	Programmed operation is possible. Can operate up to 2 axes	1500 points				→ P557

* This is for the single-axis PSEL.
* ① is a placeholder for the power supply voltage (1: 100V / 2: 100~240V).

RCP3-SA2BR

ROBO Cylinder Mini Slider Type Side-Mounted Motor Unit 28mm Width
Pulse Motor Lead Screw

■ Configuration: **RCP3** — **SA2BR** — **I** — **20P** — — — — —

Series	Type	Encoder	Motor	Lead	Stroke	Compatible Controllers	Cable Length	Option
I: Incremental * The Simple absolute encoder models are labeled as "I".	20P: Pulse motor 20 □ size	6S : 4mm lead screw 4S : 4mm lead screw 2S : 2mm lead screw	25: 25mm 150: 150mm (25mm pitch increments)	P1: PCON RPCON PSEL P3: PMEC PSEP	N : None P : 1m S : 3m M : 5m X □ : Custom Length	See Options below * Be sure to specify which side the motor is to be mounted (ML/MR).		

* See page Pre-35 for explanation of each code that make up the configuration name.

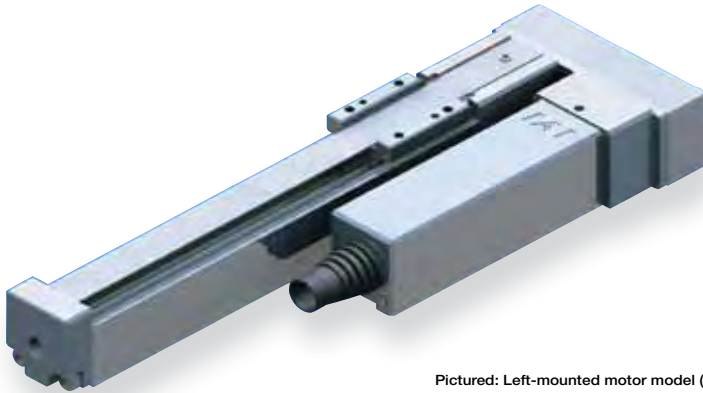

Pictured: Left-mounted motor model (ML).

Technical References A-5

■ Speed vs. Load Capacity
Due to the characteristics of the pulse motor, the RCP3 series' load capacity decreases at high speeds. In the table below, check if your desired speed and load capacity are supported.

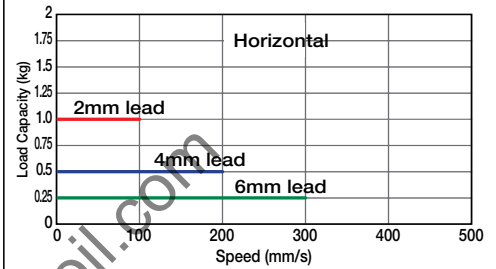

- POINT**
Notes on Selection
- (1) The load capacity is based on operation at an acceleration of 0.2G. This is the upper limit for the acceleration.
 - (2) The actuator cannot be used on its side or in a vertical orientation.
 - (3) If used in a dusty environment, the service life will decrease significantly.
 - (4) This model uses a lead screw, therefore please ensure that your usage is appropriate for its characteristics. (See page Pre-42.)

Actuator Specifications						Stroke and Maximum Speed				
■ Lead and Load Capacity						■ Stroke and Maximum Speed				
Model	Feed Screw	Lead (mm)	Max. Load Capacity		Positioning Repeatability (mm)	Stroke (mm)	Stroke			
			Horizontal (kg)	Vertical (kg)			Lead	25 (mm)	50 (mm)	75~150 (mm)
RCP3-SA2BR-I-20P-6S-①-②-③-④	Lead screw	6	0.25	-	±0.05	25~150 (25mm increments)	6	180	280	300
RCP3-SA2BR-I-20P-4S-①-②-③-④		4	0.5	-			4	180	200	
RCP3-SA2BR-I-20P-2S-①-②-③-④		2	1	-			2	100		

Legend ① Stroke ② Compatible controller ③ Cable length ④ Options (Unit: mm/s)

① Stroke List

Stroke (mm)	Standard Price
25	-
50	-
75	-
100	-
125	-
150	-

③ Cable List

Type	Cable Symbol	Standard Price
Standard (Robot Cables)	P (1m)	-
	S (3m)	-
	M (5m)	-
Special Lengths	X06 (6m) ~ X10 (10m)	-
	X11 (11m) ~ X15 (15m)	-
	X16 (16m) ~ X20 (20m)	-
		-

* The standard cable for the RCP3 is the robot cable.
* See page A-39 for cables for maintenance.

④ Option List

Name	Option Code	See Page	Standard Price
Left-Mounted Motor (Standard)	ML	→ A-33	-
Right-Mounted Motor	MR	→ A-33	-
Reversed-home	NM	→ A-33	-

Actuator Specifications

Item	Description
Drive System	Lead screw ø6mm C10 grade
Lost Motion	0.3mm or less (initial value)
Base	Material: Aluminum (white alumite treated)
Guide	Slide guide
Ambient Operating Temp./Humidity	0~40°C, 85% RH or less (non-condensing)
Service Life	10 million cycles

Dimensions

CAD drawings can be downloaded from IAI website. www.intelligentactuator.com

For Special Orders A-9



* The diagram below shows a left-mounted motor model.

- *1 A motor-encoder cable is connected here. See page A-39 for details on cables.
- *2 During the homing operation, the slider moves to actuator's mechanical end; therefore, please watch for any interference with the surrounding objects.

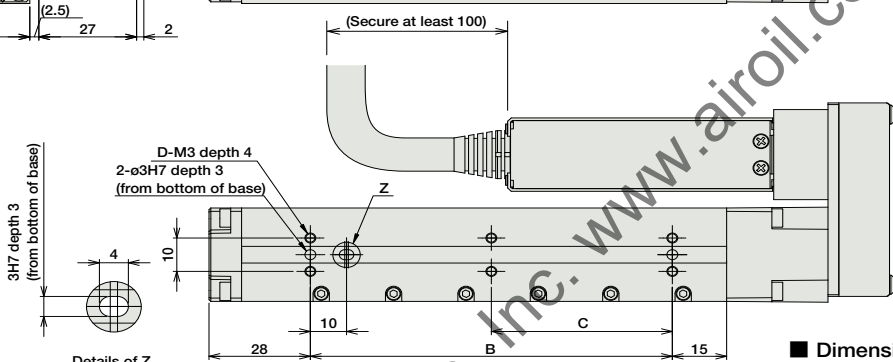
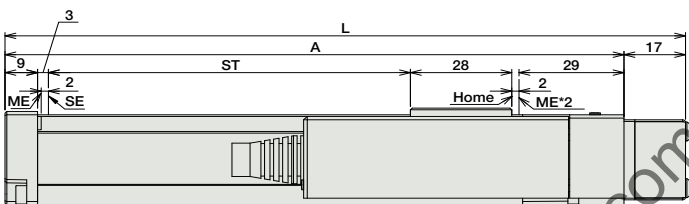
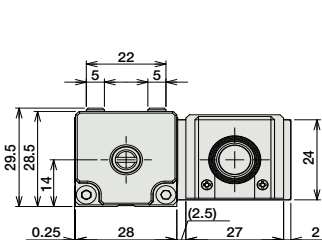
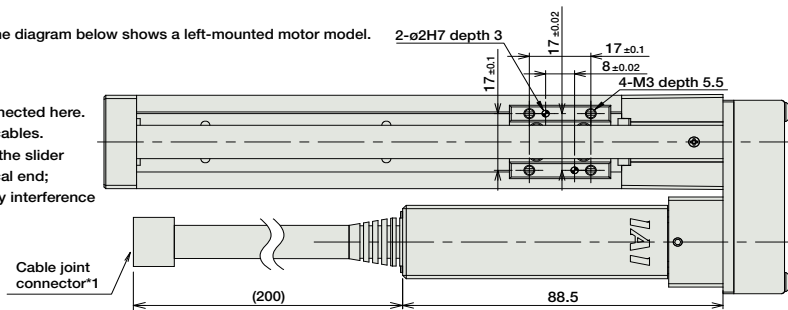

ST : Stroke
ME: Mechanical end
SE: Stroke end

■ Dimensions/Weight by Stroke

Stroke	25	50	75	100	125	150
L	113	138	163	188	213	238
A	96	121	146	171	196	221
B	25	50	75	100	125	150
C	0	0	0	50	62.5	75
D	4	4	4	6	6	6
Weight (kg)	0.32	0.34	0.37	0.39	0.42	0.46

② Compatible Controllers

The RCP3 series actuators can operate with the controllers below. Select the controller according to your usage.

Name	External View	Model	Description	Max. Positioning Points	Input Voltage	Power Supply Capacity	Standard Price	See Page
Solenoid Valve Type		PMEC-C-20PI-NP-2-①	Easy-to-use controller, even for beginners	3 points	AC100V AC200V	See P481	-	→ P477
		PSEP-C-20PI-NP-2-0	Operable with same signal as solenoid valve. Supports both single and double solenoid types. No homing necessary with simple absolute type.					
Splash-Proof Solenoid Valve Type		PSEP-CW-20PI-NP-2-0						→ P487
Positioner Type		PCON-C-20PI-NP-2-0	Positioning is possible for up to 512 points	512 points			-	
Safety-Compliant Positioner Type		PCON-CG-20PI-NP-2-0						
Pulse Train Input Type (Differential Line Driver)		PCON-PL-20PI-NP-2-0	Pulse train input type with differential line driver support	(-)			-	→ P525
Pulse Train Input Type (Open Collector)		PCON-PO-20PI-NP-2-0	Pulse train input type with open collector support					
Serial Communication Type		PCON-SE-20PI-N-0-0	Dedicated to serial communication	64 points				
Field Network Type		RPCON-20P	Dedicated to field network	768 points				→ P503
Program Control Type		PSEL-C-1-20PI-NP-2-0	Programmed operation is possible. Can operate up to 2 axes	1500 points				→ P557

* This is for the single-axis PSEL.
* ① is a placeholder for the power supply voltage (1: 100V / 2: 100~240V).

- Slider Type
- Mini
- Standard
- Controllers Integrated
- Rod Type
- Mini
- Standard
- Controllers Integrated
- Table/Arm /Flat Type
- Mini
- Standard
- Controllers Integrated
- Gripper/ Rotary Type
- Linear Servo Type
- Cleanroom Type
- Splash-Proof
- Controllers
- PMEC /AMEC
- PSEP /ASEP
- ROBO NET
- ERC2
- PCON
- ACON
- SCON
- PSEL
- ASEL
- SSEL
- XSEL
- Pulse Motor
- Servo Motor (24V)
- Servo Motor (200V)
- Linear Servo Motor

RCP3-SA3R

ROBO Cylinder Slider Type 32mm Width Pulse Motor Side-Mounted Motor

■ Configuration: **RCP3** — **SA3R** — **I** — **28P** — — — — —

Series — Type — Encoder — Motor — Lead — Stroke — Compatible Controllers — Cable Length — Option

I: Incremental
* The Simple absolute encoder models are labeled as "I".

28P: Pulse motor
28 □ size

6 : 4mm
4 : 4mm
2 : 2mm

50: 50mm
300: 300mm (50mm pitch increments)

P1: PCON
RPCON
PSEL
P3: PMEC
PSEP

N : None
P : 1m
S : 3m
M : 5m
X □ □ : Custom Length

See Options below
* Be sure to specify which side the motor is to be mounted (ML/MR).

* See page Pre-35 for explanation of each code that make up the configuration name.



Technical References A-5

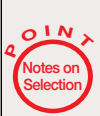

- (1) Since the RCP3 series use a pulse motor, the load capacity decreases at high speeds. Check in the Speed vs. Load Capacity graph to see if your desired speed and load capacity are supported.
- (2) The load capacity is based on operation at an acceleration of 0.3G (0.2G for the 2mm-lead model, or when used vertically). These values are the upper limits for the acceleration.

■ Speed vs. Load Capacity
Due to the characteristics of the pulse motor, the RCP3 series' load capacity decreases at high speeds. In the table below, check if your desired speed and load capacity are supported.

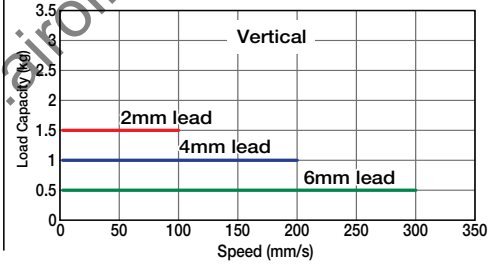
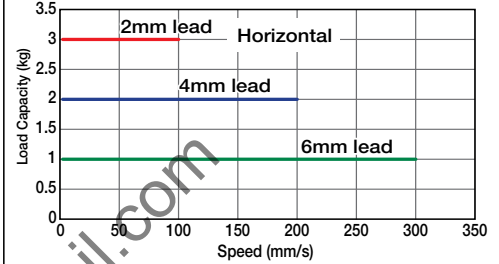

Actuator Specifications

■ Lead and Load Capacity

Model	Lead (mm)	Max. Load Capacity		Maximum Push Force (N)	Stroke (mm)
		Horizontal (kg)	Vertical (kg)		
RCP3-SA3R-I-28P-6-①-②-③-④	6	1	0.5	15	50~300 (50mm increments)
RCP3-SA3R-I-28P-4-①-②-③-④	4	2	1	22	
RCP3-SA3R-I-28P-2-①-②-③-④	2	3	1.5	44	

■ Stroke and Maximum Speed

Stroke Lead	50 ~ 300 (50mm increments)	
	Stroke	Maximum Speed
6	300	
4	200	
2	100	

Legend ① Stroke ② Compatible controller ③ Cable length ④ Options (Unit: mm/s)

① Stroke List

Stroke (mm)	Standard Price	
	With cover (standard)	No cover (Option)
50	-	-
100	-	-
150	-	-
200	-	-
250	-	-
300	-	-

③ Cable List

Type	Cable Symbol	Standard Price
Standard (Robot Cables)	P (1m)	-
	S (3m)	-
	M (5m)	-
Special Lengths	X06 (6m) ~ X10 (10m)	-
	X11 (11m) ~ X15 (15m)	-
	X16 (16m) ~ X20 (20m)	-
		-

* The standard cable is the motor-encoder integrated robot cable.
* See page A-39 for cables for maintenance.

④ Option List

Name	Option Code	See Page	Standard Price
Brake-Equipped	B	→ A-25	-
Cable Exit Direction (Top)	CJT	→ A-25	-
Cable Exit Direction (Outside)	CJO	→ A-25	-
Cable Exit Direction (Bottom)	CJB	→ A-25	-
Left-Mounted Motor (Standard)	ML	→ A-33	-
Right-Mounted Motor	MR	→ A-33	-
No Cover	NCO	→ A-33	-
Reversed-home	NM	→ A-33	-

Actuator Specifications

Item	Description
Drive System	Ball screw Ø6mm C10 grade
Positioning Repeatability	±0.02mm
Lost Motion	0.1mm or less
Base	Material: Aluminum (special alumite treated)
Allowable Static Load Moment	Ma: 5.0N·m Mb: 7.1N·m Mc: 7.9N·m
Allowable Dynamic Load Moment	Ma: 1.96N·m Mb: 2.84N·m Mc: 3.14N·m
Overhang Load Length	100mm or less
Ambient Operating Temp./Humidity	0~40°C, 85% RH or less (non-condensing)

Directions of Allowable Load Moment

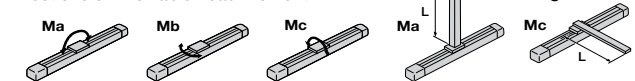

5,000 km service life

Dimensions

CAD drawings can be downloaded from IAI website. www.intelligentactuator.com



For Special Orders A-9

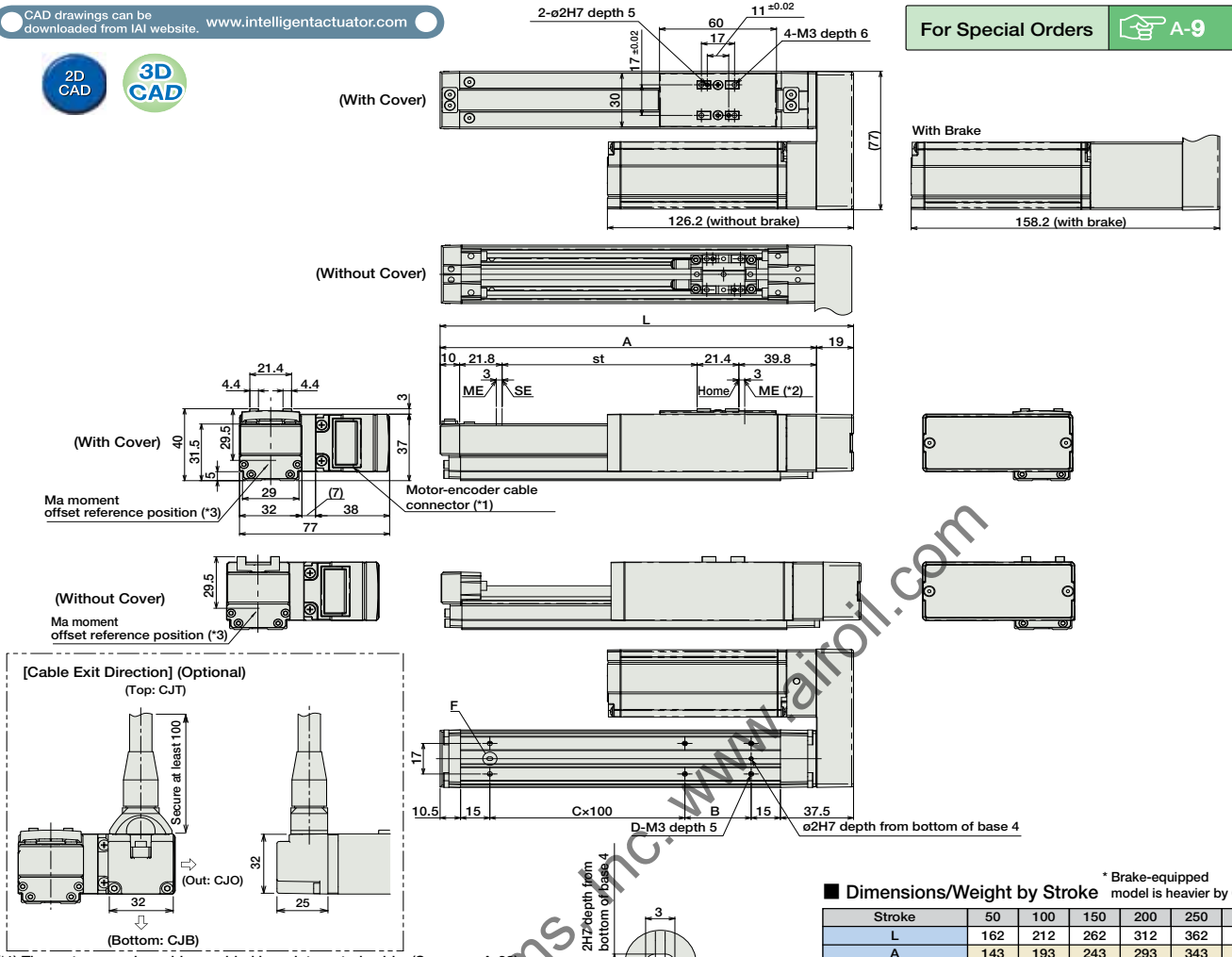

(*1) The motor-encoder cable provided is an integrated cable. (See page A-39)
 (*2) After homing, the slider moves to the ME, therefore, please watch for any interference with surrounding objects.
 ME : Mechanical end
 SE : Stroke end
 (*3) Reference position for calculating the moment Ma

■ Dimensions/Weight by Stroke * Brake-equipped model is heavier by 0.2kg.

Stroke	50	100	150	200	250	300
L	162	212	262	312	362	412
A	143	193	243	293	343	393
B	84	34	84	34	84	34
C	0	1	1	2	2	3
D	4	6	6	8	8	10
Weight (kg)	With Cover	0.8	0.8	0.9	1.0	1.1
	No Cover	0.7	0.8	0.8	0.9	1.0

② Compatible Controllers

The RCP3 series actuators can operate with the controllers below. Select the controller according to your usage.

Name	External View	Model	Description	Max. Positioning Points	Input Voltage	Power Supply Capacity	Standard Price	See Page
Solenoid Valve Type		PMEC-C-28PI-NP-2-①	Easy-to-use controller, even for beginners	3 points	AC100V AC200V	See P481	-	→ P477
		PSEP-C-28PI-NP-2-0	Operable with same signal as solenoid valve. Supports both single and double solenoid types. No homing necessary with simple absolute type.					
Splash-Proof Solenoid Valve Type		PSEP-CW-28PI-NP-2-0						→ P487
Positioner Type		PCON-C-28PI-NP-2-0	Positioning is possible for up to 512 points	512 points	DC24V	2A Max.	-	→ P525
Safety-Compliant Positioner Type		PCON-CG-28PI-NP-2-0						
Pulse Train Input Type (Differential Line Driver)		PCON-PL-28PI-NP-2-0	Pulse train input type with differential line driver support	(-)	DC24V	2A Max.	-	→ P525
Pulse Train Input Type (Open Collector)		PCON-PO-28PI-NP-2-0	Pulse train input type with open collector support					
Serial Communication Type		PCON-SE-28PI-N-0-0	Dedicated to serial communication	64 points				
Field Network Type		RPCON-28P	Dedicated to field network	768 points				→ P503
Program Control Type		PSEL-C-1-28PI-NP-2-0	Programmed operation is possible. Can operate up to 2 axes	1500 points				→ P557

* This is for the single-axis PSEL.
 * ① is a placeholder for the power supply voltage (1: 100V / 2: 100~240V).

- Slider Type
- Mini
- Standard
- Controllers Integrated
- Rod Type
- Mini
- Standard
- Controllers Integrated
- Table/Arm/Flat Type
- Mini
- Standard
- Gripper/Rotary Type
- Linear Servo Type
- Cleanroom Type
- Splash-Proof
- Controllers
- PMEC/AMEC
- PSEP/ASEP
- ROBO NET
- ERC2
- PCON
- ACON
- SCON
- PSEL
- ASEL
- SSEL
- XSEL
- Pulse Motor
- Servo Motor (24V)
- Servo Motor (200V)
- Linear Servo Motor

RCP3-SA4R

ROBO Cylinder Slider Type 40mm Width Pulse Motor Side-Mounted Motor

■ Configuration: **RCP3** — **SA4R** — **I** — **35P** — [] — [] — [] — [] — []

Series — Type — Encoder — Motor — Lead — Stroke — Compatible Controllers — Cable Length — Option

I: Incremental * The Simple absolute encoder models are labeled as "I".
 35P: Pulse motor 35 □ size
 10 : 10mm
 5 : 5mm
 2.5 : 2.5mm
 50: 50mm
 500: 500mm (50mm pitch increments)
 P1: PCON
 RPCON
 PSEL
 P3: PMEC
 PSEP
 N : None
 P : 1m
 S : 3m
 M : 5m
 X □ □ : Custom Length
 See Options below
 * Be sure to specify which side the motor is to be mounted (ML/MR).

* See page Pre-35 for explanation of each code that make up the configuration name.



Technical References A-5



- (1) Since the RCP3 series use a pulse motor, the load capacity decreases at high speeds. Check in the Speed vs. Load Capacity graph to see if your desired speed and load capacity are supported.
- (2) The load capacity is based on operation at an acceleration of 0.3G (0.2G for the 2.5mm-lead model, or when used vertically). These values are the upper limits for the acceleration.

■ Speed vs. Load Capacity
 Due to the characteristics of the pulse motor, the RCP3 series' load capacity decreases at high speeds. In the table below, check if your desired speed and load capacity are supported.

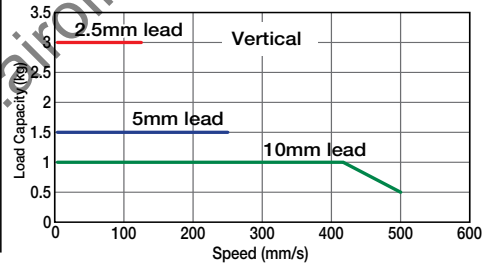
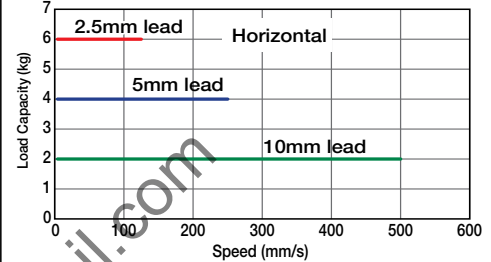

Actuator Specifications

■ Lead and Load Capacity

Model	Lead (mm)	Max. Load Capacity		Maximum Push Force (N)	Stroke (mm)
		Horizontal (kg)	Vertical (kg)		
RCP3-SA4R-I-35P-10-①-②-③-④	10	2	~ 1	34	50~500 (50mm increments)
RCP3-SA4R-I-35P-5-①-②-③-④	5	4	1.5	68	
RCP3-SA4R-I-35P-2.5-①-②-③-④	2.5	6	3	136	

■ Stroke and Maximum Speed

Stroke Lead	50 ~ 500 (50mm increments)	
	Stroke	Maximum Speed
10	500	
5	250	
2.5	125	

Legend ① Stroke ② Compatible controller ③ Cable length ④ Options (Unit: mm/s)

① Stroke List

Stroke (mm)	Standard Price	
	With cover (standard)	No cover (Option)
50	-	-
100	-	-
150	-	-
200	-	-
250	-	-
300	-	-
350	-	-
400	-	-
450	-	-
500	-	-

③ Cable List

Type	Cable Symbol	Standard Price
Standard (Robot Cables)	P (1m)	-
	S (3m)	-
	M (5m)	-
Special Lengths	X06 (6m) ~ X10 (10m)	-
	X11 (11m) ~ X15 (15m)	-
	X16 (16m) ~ X20 (20m)	-

* The standard cable is the motor-encoder integrated robot cable.
 * See page A-39 for cables for maintenance.

④ Option List

Name	Option Code	See Page	Standard Price
Brake-Equipped	B	→ A-25	-
Cable Exit Direction (Top)	CJT	→ A-25	-
Cable Exit Direction (Outside)	CJO	→ A-25	-
Cable Exit Direction (Bottom)	CJB	→ A-25	-
Left-Mounted Motor (Standard)	ML	→ A-33	-
Right-Mounted Motor	MR	→ A-33	-
No Cover	NCO	→ A-33	-
Reversed-home	NM	→ A-33	-

Actuator Specifications

Item	Description
Drive System	Ball screw Ø8mm C10 grade
Positioning Repeatability	±0.02mm
Lost Motion	0.1mm or less
Base	Material: Aluminum (special alumite treated)
Allowable Static Load Moment	Ma: 6.8N·m Mb: 9.7N·m Mc: 13.3N·m
Allowable Dynamic Load Moment	Ma: 3.04N·m Mb: 4.31N·m Mc: 5.00N·m
Overhang Load Length	120mm or less
Ambient Operating Temp./Humidity	0~40°C, 85% RH or less (non-condensing)

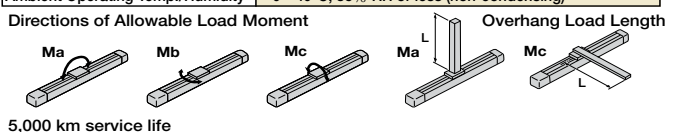

Dimensions

CAD drawings can be downloaded from IAI website. www.intelligentactuator.com



For Special Orders A-9

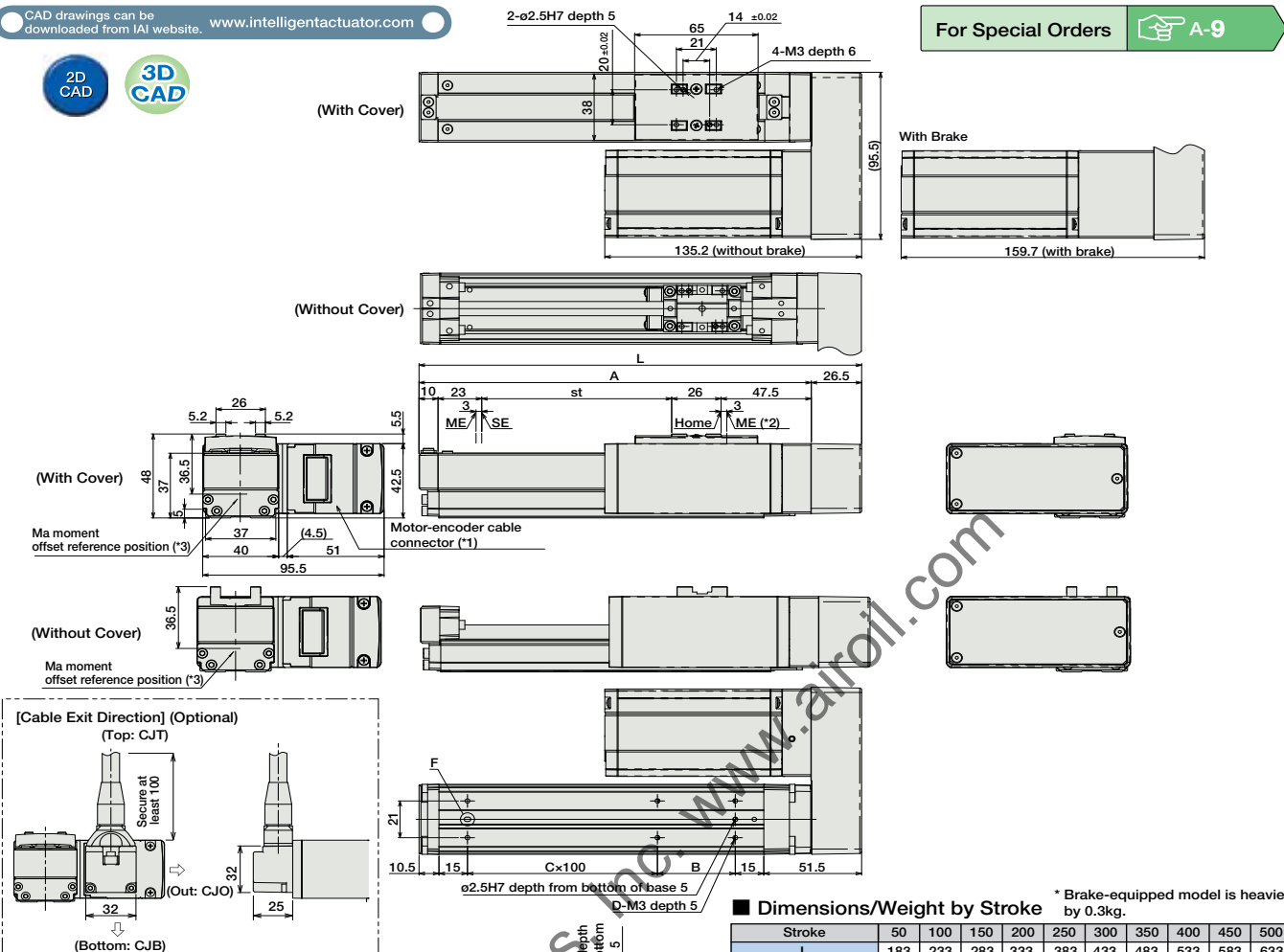

■ Dimensions/Weight by Stroke * Brake-equipped model is heavier by 0.3kg.

Stroke	50	100	150	200	250	300	350	400	450	500
L	183	233	283	333	383	433	483	533	583	633
A	156.5	206.5	256.5	306.5	356.5	406.5	456.5	506.5	556.5	606.5
B	91	41	91	41	91	41	91	41	91	41
C	0	1	1	2	2	3	3	4	4	5
D	4	6	6	8	8	10	10	12	12	14
Weight (kg)	With Cover	1.1	1.2	1.3	1.4	1.5	1.6	1.7	1.8	1.9
	No Cover	1.1	1.1	1.2	1.3	1.4	1.4	1.5	1.6	1.7

(*1) The motor-encoder cable provided is an integrated cable. (See page A-39)
 (*2) After homing, the slider moves to the ME, therefore, please watch for any interference with surrounding objects.
 ME : Mechanical end
 SE : Stroke end
 (*3) Reference position for calculating the moment Ma

② Compatible Controllers

The RCP3 series actuators can operate with the controllers below. Select the controller according to your usage.

Name	External View	Model	Description	Max. Positioning Points	Input Voltage	Power Supply Capacity	Standard Price	See Page
Solenoid Valve Type		PMEC-C-35PI-NP-2-①	Easy-to-use controller, even for beginners	3 points	AC100V AC200V	See P481	-	→ P477
		PSEP-C-35PI-NP-2-0	Operable with same signal as solenoid valve. Supports both single and double solenoid types. No homing necessary with simple absolute type.					
Splash-Proof Solenoid Valve Type		PSEP-CW-35PI-NP-2-0						
Positioner Type		PCON-C-35PI-NP-2-0	Positioning is possible for up to 512 points	512 points	DC24V	2A Max.	-	→ P525
Safety-Compliant Positioner Type		PCON-CG-35PI-NP-2-0						
Pulse Train Input Type (Differential Line Driver)		PCON-PL-35PI-NP-2-0	Pulse train input type with differential line driver support	(-)	DC24V	2A Max.	-	→ P525
Pulse Train Input Type (Open Collector)		PCON-PO-35PI-NP-2-0	Pulse train input type with open collector support					
Serial Communication Type		PCON-SE-35PI-N-0-0	Dedicated to serial communication	64 points				
Field Network Type		RPCON-35P	Dedicated to field network	768 points				→ P503
Program Control Type		PSEL-C-1-35PI-NP-2-0	Programmed operation is possible. Can operate up to 2 axes	1500 points				→ P557

* This is for the single-axis PSEL.
 * ① is a placeholder for the power supply voltage (1: 100V / 2: 100~240V).

RCP3-SA5R

ROBO Cylinder Slider Type 50mm Width Pulse Motor Side-Mounted Motor

■ Configuration: **RCP3** — **SA5R** — **I** — **42P** — [] — [] — [] — [] — []

Series	Type	Encoder	Motor	Lead	Stroke	Compatible Controllers	Cable Length	Option
I: Incremental * The Simple absolute encoder models are labeled as "I".	42P: Pulse motor 42 □ size	12 : 12mm 6 : 6mm 3 : 3mm	50: 50mm 800: 800mm (50mm pitch increments)	P1: PCON RPCON PSEL P3: PMEC PSEP	N : None P : 1m S : 3m M : 5m X □ □ : Custom Length	See Options below * Be sure to specify which side the motor is to be mounted (ML/MR).		

* See page Pre-35 for explanation of each code that make up the configuration name.



Technical References A-5



- (1) Since the RCP3 series use a pulse motor, the load capacity decreases at high speeds. Check in the Speed vs. Load Capacity graph to see if your desired speed and load capacity are supported.
- (2) The load capacity is based on operation at an acceleration of 0.3G (0.2G for the 3mm-lead model, or when used vertically). These values are the upper limits for the acceleration.

■ Speed vs. Load Capacity
Due to the characteristics of the pulse motor, the RCP3 series' load capacity decreases at high speeds. In the table below, check if your desired speed and load capacity are supported.

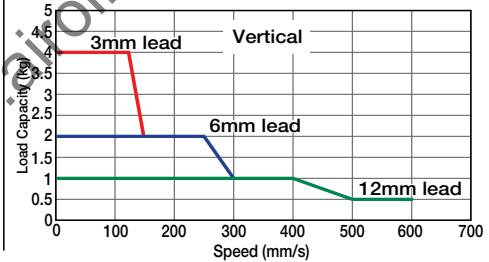
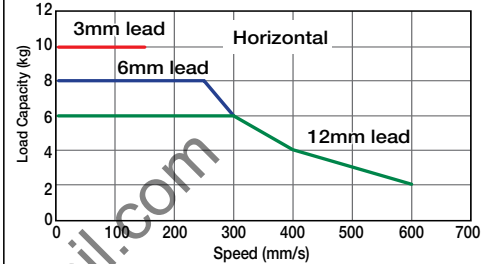

Actuator Specifications

Lead and Load Capacity

Model	Lead (mm)	Max. Load Capacity		Maximum Push Force (N)	Stroke (mm)
		Horizontal (kg)	Vertical (kg)		
RCP3-SA5R-I-42P-12-①-②-③-④	12	~6	~1	47	50~800 (50mm increments)
RCP3-SA5R-I-42P-6-①-②-③-④	6	~8	~2	95	
RCP3-SA5R-I-42P-3-①-②-③-④	3	10	~4	189	

Stroke and Maximum Speed

Stroke/Lead	50 ~ 550	600	650	700	750	800
	(50mm increments)	(mm)	(mm)	(mm)	(mm)	(mm)
12	600	570	490	425	370	330
6	300	285	245	210	185	165
3	150	140	120	105	90	80

(Unit: mm/s)

Legend ① Stroke ② Compatible controller ③ Cable length ④ Options

① Stroke List

Stroke (mm)	Standard Price	
	With cover (standard)	No cover (Option)
50	-	-
100	-	-
150	-	-
200	-	-
250	-	-
300	-	-
350	-	-
400	-	-
450	-	-
500	-	-
550	-	-
600	-	-
650	-	-
700	-	-
750	-	-
800	-	-

③ Cable List

Type	Cable Symbol	Standard Price
Standard (Robot Cables)	P (1m)	-
	S (3m)	-
	M (5m)	-
Special Lengths	X06 (6m) ~ X10 (10m)	-
	X11 (11m) ~ X15 (15m)	-
	X16 (16m) ~ X20 (20m)	-

* The standard cable is the motor-encoder integrated robot cable.

* See page A-39 for cables for maintenance.

④ Option List

Name	Option Code	See Page	Standard Price
Brake-Equipped	B	→ A-25	-
Cable Exit Direction (Top)	CJT	→ A-25	-
Cable Exit Direction (Outside)	CJO	→ A-25	-
Cable Exit Direction (Bottom)	CJB	→ A-25	-
Left-Mounted Motor (Standard)	ML	→ A-33	-
Right-Mounted Motor	MR	→ A-33	-
No Cover	NCO	→ A-33	-
Reversed-home	NM	→ A-33	-

Actuator Specifications

Item	Description
Drive System	Ball screw Ø10mm C10 grade
Positioning Repeatability	±0.02mm
Lost Motion	0.1mm or less
Base	Material: Aluminum (special alumite treated)
Allowable Static Load Moment	Ma: 10.2N·m Mb: 14.6N·m Mc: 8.53N·m
Allowable Dynamic Load Moment	Ma: 3.92N·m Mb: 5.58N·m Mc: 8.53N·m
Overhang Load Length	130mm or less
Ambient Operating Temp./Humidity	0~40°C, 85% RH or less (non-condensing)

Directions of Allowable Load Moment

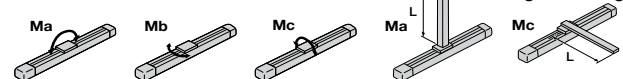

5,000 km service life

Dimensions

CAD drawings can be downloaded from IAI website. www.intelligentactuator.com



For Special Orders A-9

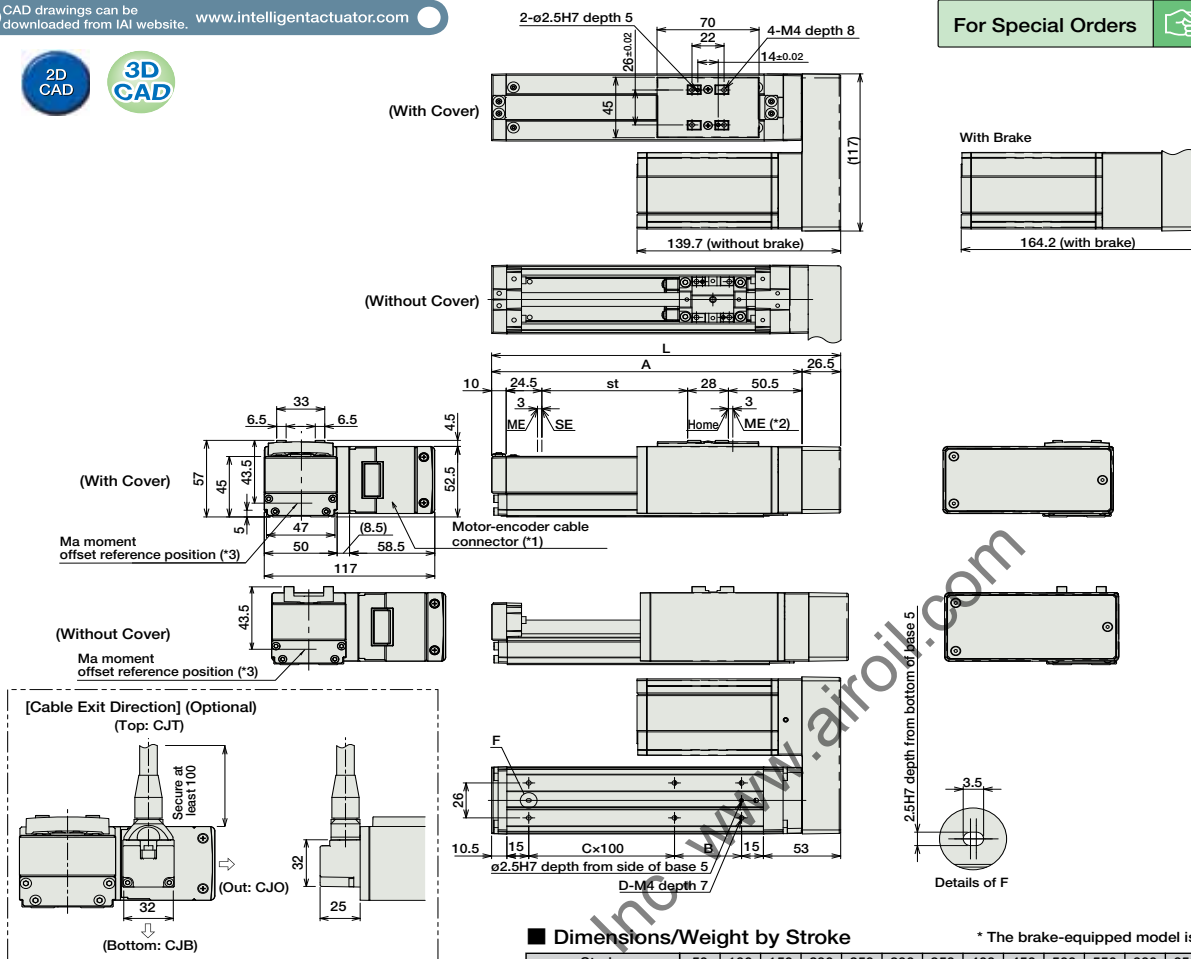

■ Dimensions/Weight by Stroke

* The brake-equipped model is heavier by 0.4kg.

Stroke	50	100	150	200	250	300	350	400	450	500	550	600	650	700	750	800
L	189.5	239.5	289.5	339.5	389.5	439.5	489.5	539.5	589.5	639.5	689.5	739.5	789.5	839.5	889.5	939.5
A	163	213	263	313	363	413	463	513	563	613	663	713	763	813	863	913
B	96	46	96	46	96	46	96	46	96	46	96	46	96	46	96	46
C	0	1	1	2	2	3	3	4	4	5	5	6	6	7	7	8
D	4	6	6	8	8	10	10	12	12	14	14	16	16	18	18	20
Weight (kg)	With Cover	1.7	1.8	1.9	2.1	2.2	2.3	2.5	2.6	2.8	2.9	3.0	3.2	3.3	3.4	3.6
	No Cover	1.6	1.7	1.8	1.9	2.0	2.1	2.3	2.4	2.5	2.6	2.7	2.8	2.9	3.1	3.2

(*1) The motor-encoder cable provided is an integrated cable. (See page A-39.)

(*2) After homing, the slider moves to the ME; therefore, please watch for any interference with surrounding objects.

ME : Mechanical end
SE : Stroke end

(*3) Reference position for calculating the moment Ma

② Compatible Controllers

The RCP3 series actuators can operate with the controllers below. Select the controller according to your usage.

Name	External View	Model	Description	Max. Positioning Points	Input Voltage	Power Supply Capacity	Standard Price	See Page
Solenoid Valve Type		PMEC-C-42PI-NP-2-①	Easy-to-use controller, even for beginners	3 points	AC100V AC200V	See P481	-	→ P477
		PSEP-C-42PI-NP-2-0	Operable with same signal as solenoid valve. Supports both single and double solenoid types. No homing necessary with simple absolute type.					
Splash-Proof Solenoid Valve Type		PSEP-CW-42PI-NP-2-0						
Positioner Type		PCON-C-42PI-NP-2-0	Positioning is possible for up to 512 points	512 points	DC24V	2A Max.	-	→ P525
Safety-Compliant Positioner Type		PCON-CG-42PI-NP-2-0						
Pulse Train Input Type (Differential Line Driver)		PCON-PL-42PI-NP-2-0	Pulse train input type with differential line driver support	(-)	DC24V	2A Max.	-	→ P525
Pulse Train Input Type (Open Collector)		PCON-PO-42PI-NP-2-0	Pulse train input type with open collector support					
Serial Communication Type		PCON-SE-42PI-N-0-0	Dedicated to serial communication	64 points				
Field Network Type		RPCON-42P	Dedicated to field network	768 points				→ P503
Program Control Type		PSEL-C-1-42PI-NP-2-0	Programmed operation is possible. Can operate up to 2 axes	1500 points				→ P557

* This is for the single-axis PSEL.

* ① is a placeholder for the power supply voltage (1: 100V / 2: 100~240V).

RCP3-SA6R

ROBO Cylinder Slider Type 60mm Width Pulse Motor Side-Mounted Motor

Configuration: **RCP3** — **SA6R** — **I** — **42P** — — — — —

Series — Type — Encoder — Motor — Lead — Stroke — Compatible Controllers — Cable Length — Option

I: Incremental
 * The Simple absolute encoder models are labeled as "I".

42P: Pulse motor
 42 □ size

12 : 12mm
 6 : 6mm
 3 : 3mm

50: 50mm
 800: 800mm (50mm pitch increments)

P1: PCON
 RPCON
 PSEL
 P3: PMEC
 PSEP

N : None
 P : 1m
 S : 3m
 M : 5m
 X □ □ : Custom Length

See Options below
 * Be sure to specify which side the motor is to be mounted (ML/MR).

* See page Pre-35 for explanation of each code that make up the configuration name.



Technical References A-5

- POINT** Notes on Selection
- When the stroke increases, the maximum speed will drop to prevent the ball screw from reaching the critical rotational speed. Use the actuator specification table below to check the maximum speed at the stroke you desire.
 - Since the RCP3 series use the pulse motor, the load capacity decreases at high speeds. Check in the Speed vs. Load Capacity graph to see if your desired speed and load capacity are supported.
 - The load capacity is based on operation at an acceleration of 0.3G (0.2G for the 3mm-lead model, or when used vertically). These values are the upper limits for the acceleration.

Speed vs. Load Capacity
 Due to the characteristics of the pulse motor, the RCP3 series' load capacity decreases at high speeds. In the table below, check if your desired speed and load capacity are supported.

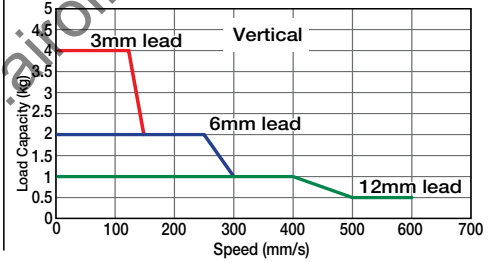
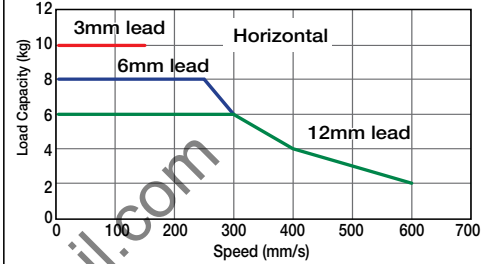

Actuator Specifications

Lead and Load Capacity

Model	Lead (mm)	Max. Load Capacity		Maximum Push Force (N)	Stroke (mm)
		Horizontal (kg)	Vertical (kg)		
RCP3-SA6R-I-42P-12-①-②-③-④	12	~6	~1	47	50~800 (50mm increments)
RCP3-SA6R-I-42P-6-①-②-③-④	6	~8	~2	95	
RCP3-SA6R-I-42P-3-①-②-③-④	3	10	~4	189	

Stroke and Maximum Speed

Stroke/Lead	50 ~ 550 (50mm increments)	600 (mm)	650 (mm)	700 (mm)	750 (mm)	800 (mm)
	12	600	570	490	425	370
6	300	285	245	210	185	165
3	150	140	120	105	90	80

(Unit: mm/s)

Legend ① Stroke ② Compatible controller ③ Cable length ④ Options

① Stroke List

Stroke (mm)	Standard Price	
	With cover (standard)	No cover (Option)
50	-	-
100	-	-
150	-	-
200	-	-
250	-	-
300	-	-
350	-	-
400	-	-
450	-	-
500	-	-
550	-	-
600	-	-
650	-	-
700	-	-
750	-	-
800	-	-

④ Option List

Name	Option Code	See Page	Standard Price
Brake-Equipped	B	→ A-25	—
Cable Exit Direction (Top)	CJT	→ A-25	—
Cable Exit Direction (Outside)	CJO	→ A-25	—
Cable Exit Direction (Bottom)	CJB	→ A-25	—
Left-Mounted Motor (Standard)	ML	→ A-33	—
Right-Mounted Motor	MR	→ A-33	—
No Cover	NCO	→ A-33	—
Reversed-home	NM	→ A-33	—

③ Cable List

Type	Cable Symbol	Standard Price
Standard (Robot Cables)	P (1m)	—
	S (3m)	—
	M (5m)	—
Special Lengths	X06 (6m) ~ X10 (10m)	—
	X11 (11m) ~ X15 (15m)	—
	X16 (16m) ~ X20 (20m)	—

* The standard cable is the motor-encoder integrated robot cable.
 * See page A-39 for cables for maintenance.

Actuator Specifications

Item	Description
Drive System	Ball screw Ø10mm C10 grade
Positioning Repeatability	±0.02mm
Lost Motion	0.1mm or less
Base	Material: Aluminum (special alumite treated)
Allowable Static Load Moment	Ma: 17.6N-m Mb: 25.2N-m Mc: 44.5N-m
Allowable Dynamic Load Moment	Ma: 4.31N-m Mb: 6.17N-m Mc: 10.98N-m
Overhang Load Length	150mm or less
Ambient Operating Temp./Humidity	0~40°C, 85% RH or less (non-condensing)

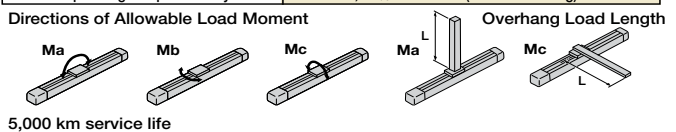

Dimensions

CAD drawings can be downloaded from IAI website. www.intelligentactuator.com



- (*1) The motor-encoder cable provided is an integrated cable. (See page A-39)
- (*2) After homing, the slider moves to the ME; therefore, please watch for any interference with surrounding objects.
ME : Mechanical end
SE : Stroke end
- (*3) Reference position for calculating the moment Ma

For Special Orders A-9

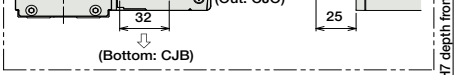
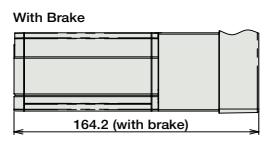
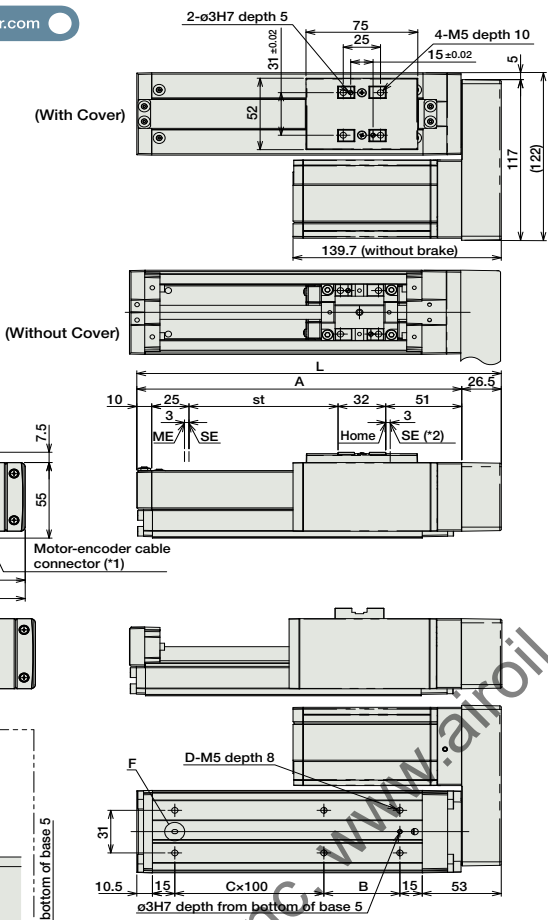
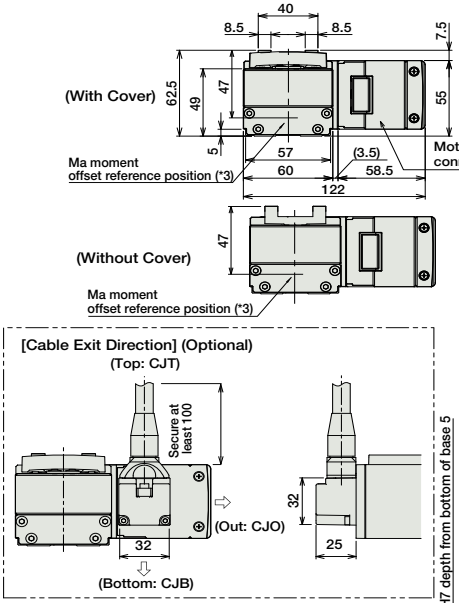

Dimensions/Weight by Stroke

* The brake-equipped model is heavier by 0.4kg.

Stroke	50	100	150	200	250	300	350	400	450	500	550	600	650	700	750	800	
L	194.5	244.5	294.5	344.5	394.5	444.5	494.5	544.5	594.5	644.5	694.5	744.5	794.5	844.5	894.5	944.5	
A	168	218	268	318	368	418	468	518	568	618	668	718	768	818	868	918	
B	101	51	101	51	101	51	101	51	101	51	101	51	101	51	101	51	
C	0	1	1	2	2	3	3	4	4	5	5	6	6	7	7	8	
D	4	6	6	8	8	10	10	12	12	14	14	16	16	18	18	20	
Weight (kg)	With Cover	1.9	2.1	2.3	2.4	2.6	2.8	3.0	3.1	3.3	3.5	3.6	3.8	4.0	4.2	4.3	4.5
	No Cover	1.8	2.0	2.1	2.3	2.4	2.6	2.7	2.9	3.0	3.1	3.3	3.4	3.6	3.7	3.9	4.0

Compatible Controllers

The RCP3 series actuators can operate with the controllers below. Select the controller according to your usage.

Name	External View	Model	Description	Max. Positioning Points	Input Voltage	Power Supply Capacity	Standard Price	See Page
Solenoid Valve Type		PMEC-C-42PI-NP-2-①	Easy-to-use controller, even for beginners	3 points	AC100V AC200V	See P481	-	→ P477
		PSEP-C-42PI-NP-2-0	Operable with same signal as solenoid valve. Supports both single and double solenoid types. No homing necessary with simple absolute type.					
Splash-Proof Solenoid Valve Type		PSEP-CW-42PI-NP-2-0						
Positioner Type		PCON-C-42PI-NP-2-0	Positioning is possible for up to 512 points	512 points				
Safety-Compliant Positioner Type		PCON-CG-42PI-NP-2-0						
Pulse Train Input Type (Differential Line Driver)		PCON-PL-42PI-NP-2-0	Pulse train input type with differential line driver support	(-)	DC24V	2A Max.		→ P525
Pulse Train Input Type (Open Collector)		PCON-PO-42PI-NP-2-0	Pulse train input type with open collector support					
Serial Communication Type		PCON-SE-42PI-N-0-0	Dedicated to serial communication	64 points				
Field Network Type		RPCON-42P	Dedicated to field network	768 points				→ P503
Program Control Type		PSEL-C-1-42PI-NP-2-0	Programmed operation is possible. Can operate up to 2 axes	1500 points				→ P557

* This is for the single-axis PSEL.
* ① is a placeholder for the power supply voltage (1: 100V / 2: 100~240V).

- Slider Type
- Mini
- Standard
- Controllers Integrated
- Rod Type
- Mini
- Standard
- Controllers Integrated
- Table/Arm/Flat Type
- Mini
- Standard
- Controllers Integrated
- Gripper/Rotary Type
- Linear Servo Type
- Cleanroom Type
- Splash-Proof
- Controllers
- PMEC/AMEC
- PSEP/ASEP
- ROBO NET
- ERC2
- PCON
- ACON
- SCON
- PSEL
- ASEL
- SSEL
- XSEL
- Pulse Motor
- Servo Motor (24V)
- Servo Motor (200V)
- Linear Servo Motor

RCP2-SA5C

ROBO Cylinder Slider Type 52mm Width Pulse Motor Straight Type Coupled

■ Configuration: **RCP2** — **SA5C** — **I** — **42P** — — — — —

Series — Type — Encoder — Motor — Lead — Stroke — Compatible Controllers — Cable Length — Option

I: Incremental
* The Simple absolute encoder models are labeled as "I".

42P: Pulse motor
42 □ size

12: 12mm
6: 6mm
3: 3mm

50: 50mm
800: 800mm (50mm pitch increments)

P1: PCON
RPCON
PSEL
P3: PMEC
PSEP

N: None
P: 1m
S: 3m
M: 5m
X □ □: Custom Length
R □ □: Robot cable

BE: Brake (Cable exiting end)
BL: Brake (Cable exiting left)
BR: Brake (Cable exiting right)
NM: Reversed-home
SR: Slider Roller

* See page Pre-35 for explanation of each code that makes up the configuration name.

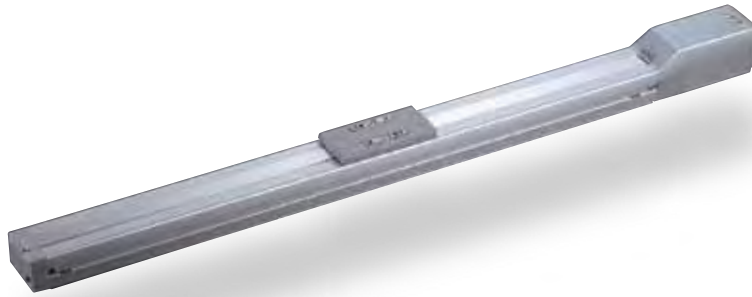

Technical References A-5

POINT Notes on Selection

- When the stroke increases, the maximum speed will drop to prevent the ball screw from reaching the critical rotational speed. Use the actuator specification table below to check the maximum speed at the stroke you desire.
- Since the RCP2 series use a pulse motor, the load capacity decreases at high speeds. Check in the Speed vs. Load Capacity graph to see if your desired speed and load capacity are supported.
- The load capacity is based on operation at an acceleration of 0.3G (0.2G for the 3mm-lead model, or when used vertically). The maximum acceleration is 0.7G (0.3G when used vertically), however, note that the load capacity decreases at high accelerations. For more information, see the table of load capacity by acceleration, on page A-53.

■ Speed vs. Load Capacity
Due to the characteristics of the pulse motor, the RCP2 series' load capacity decreases at high speeds. In the table below, check if your desired speed and load capacity are supported.

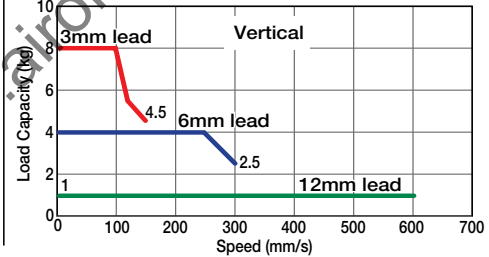
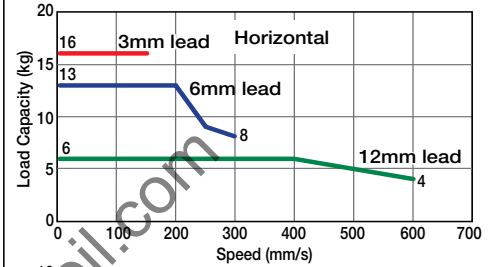

Actuator Specifications			
Lead and Load Capacity		Stroke and Maximum Speed	
(Note 1) Please note that the maximum load capacity decreases as the speed increases.			
Model	Lead (mm)	Max. Load Capacity (Note 1)	Stroke (mm)
RCP2-SA5C-I-42P-12-①-②-③-④	12	~ 6	50 ~ 800 (50mm increments)
RCP2-SA5C-I-42P-6-①-②-③-④	6	~ 13	
RCP2-SA5C-I-42P-3-①-②-③-④	3	16	
		Horizontal (kg)	Vertical (kg)
Legend ① Stroke ② Compatible controller ③ Cable length ④ Options			

Stroke Lead	50 ~ 550 (50mm increments)	600 (mm)	650 (mm)	700 (mm)	750 (mm)	800 (mm)
12	600	540	460	400	360	300
6	300	270	230	200	180	150
3	150	135	115	100	90	75

(Unit: mm/s)

① Stroke List

Stroke (mm)	Standard Price
50	-
100	-
150	-
200	-
250	-
300	-
350	-
400	-
450	-
500	-
550	-
600	-
650	-
700	-
750	-
800	-

③ Cable List

Type	Cable Symbol	Standard Price
Standard	P (1m)	-
	S (3m)	-
	M (5m)	-
Special Lengths	X06 (6m) ~ X10 (10m)	-
	X11 (11m) ~ X15 (15m)	-
	X16 (16m) ~ X20 (20m)	-
	R01 (1m) ~ R03 (3m)	-
Robot Cable	R04 (4m) ~ R05 (5m)	-
	R06 (6m) ~ R10 (10m)	-
	R11 (11m) ~ R15 (15m)	-
	R16 (16m) ~ R20 (20m)	-

* See page A-39 for cables for maintenance.

④ Option List

Name	Option Code	See Page	Standard Price
Brake (Cable-exit end)	BE	→ A-25	-
Brake (Cable exiting left)	BL	→ A-25	-
Brake (Cable exiting right)	BR	→ A-25	-
Reversed-home	NM	→ A-33	-
Slider Roller	SR	→ A-36	-

Actuator Specifications

Item	Description
Drive System	Ball screw Ø10mm C10 grade
Positioning Repeatability	±0.02mm
Lost Motion	0.1mm or less
Base	Material: Aluminum (special alumite treated)
Allowable Static Moment	Ma: 18.6 N-m Mb: 26.6 N-m Mc: 47.5 N-m
Allowable Dynamic Moment (*)	Ma: 4.9 N-m Mb: 6.8 N-m Mc: 11.7 N-m
Overhang Load Length	Ma direction: 150mm or less; Mb-Mc direction: 150mm or less
Ambient Operating Temp./Humidity	0~40°C, 85% RH or less (Non-condensing)

(*) Based on 5,000km travel life.
Directions of Allowable Load Moments

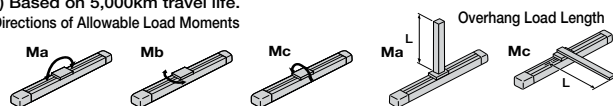

Dimensions

CAD drawings can be downloaded from IAI website. www.intelligentactuator.com

For Special Orders A-9



*For the Reversed-home model, the dimensions (distance to home) on the motor-side and that on the opposite side are flipped.

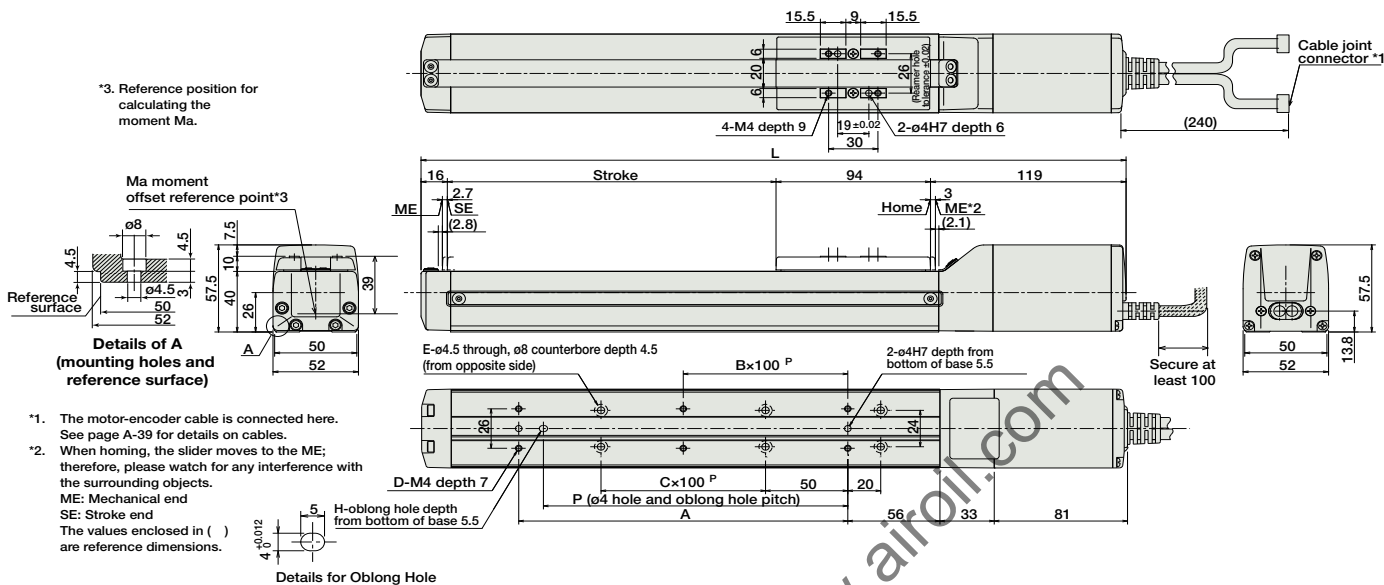

Dimensions of the brake section

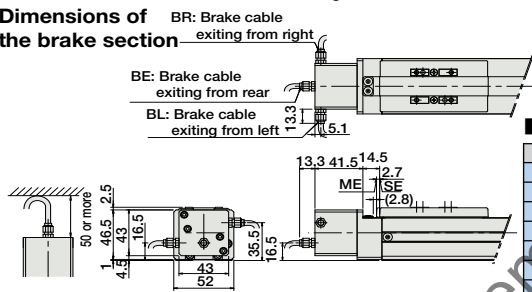

Dimensions/Weight by Stroke

Stroke	50	100	150	200	250	300	350	400	450	500	550	600	650	700	750	800
L	279	329	379	429	479	529	579	629	679	729	779	829	879	929	979	1029
A	73	100	100	200	200	300	300	400	400	500	500	600	600	700	700	800
B	0	0	0	1	1	2	2	3	3	4	4	5	5	6	6	7
C	0	0	1	1	2	2	3	3	4	4	5	5	6	6	7	7
D	4	4	4	6	6	8	8	10	10	12	12	14	14	16	16	18
E	4	4	6	6	8	8	10	10	12	12	14	14	16	16	18	18
H	0	1	1	1	1	1	1	1	1	1	1	1	1	1	1	1
P	0	85	85	185	185	285	285	385	385	485	485	585	585	685	685	785
Weight (kg)	1.5	1.6	1.7	1.8	1.9	2.1	2.2	2.3	2.4	2.5	2.6	2.8	2.9	3.0	3.1	3.2

* Adding a brake increases the actuator's overall length by 40mm (53.3mm with the cable coming out its end), and its weight by 0.4kg.

Compatible Controllers

The RCP2 series actuators can operate with the controllers below. Select the controller according to your usage.

Name	External View	Model	Description	Max. Positioning Points	Input Voltage	Power Supply Capacity	Standard Price	See Page
Solenoid Valve Type		PMEC-C-42PI-NP-2-①	Easy-to-use controller, even for beginners	3 points	AC100V AC200V	See P481	-	→ P477
		PSEP-C-42PI-NP-2-0-H	Operable with same signal as solenoid valve. Supports both single and double solenoid types. No homing necessary with simple absolute type.					
Splash-Proof Solenoid Valve Type		PSEP-CW-42PI-NP-2-0-H					-	
Positioner Type		PCON-C-42PI-NP-2-0-H	Positioning is possible for up to 512 points	512 points			-	
Safety-Compliant Positioner Type		PCON-CG-42PI-NP-2-0-H						
Pulse Train Input Type (Differential Line Driver)		PCON-PL-42PI-NP-2-0-H	Pulse train input type with differential line driver support	(-)	DC24V	2A max.	-	→ P525
Pulse Train Input Type (Open Collector)		PCON-PO-42PI-NP-2-0-H	Pulse train input type with open collector support					
Serial Communication Type		PCON-SE-42PI-N-0-0-H	Dedicated to serial communication	64 points			-	
Field Network Type		RPCON-42P-H	Dedicated to field network	768 points			-	→ P503
Program Control Type		PSEL-C-1-42PI-NP-2-0-H	Programmed operation is possible. Can operate up to 2 axes	1500 points			-	→ P557

* This is for the single-axis PSEL.
* ① is a placeholder for the power supply voltage (1: 100V / 2: 100~240V).

RCP2-SA6C

ROBO Cylinder Slider Type 58mm Width Pulse Motor Straight Type Coupled

■ Configuration: **RCP2** — **SA6C** — **I** — **42P** — — — — —

Series — Type — Encoder — Motor — Lead — Stroke — Compatible Controllers — Cable Length — Option

I: Incremental * The Simple absolute encoder models are labeled as "I".
 42P: Pulse motor 42 □ size
 12: 12mm 6: 6mm 3: 3mm
 50: 50mm 800: 800mm (50mm pitch increments)
 P1: PCON RPCON PSEL P3: PMEC PSEP
 N: None P: 1m S: 3m M: 5m X □ □: Custom Length R □ □: Robot cable
 BE: Brake (Cable exiting end) BL: Brake (Cable exiting left) BR: Brake (Cable exiting right) NM: Reversed-home SR: Slider Roller

* See page Pre-35 for explanation of each code that makes up the configuration name.

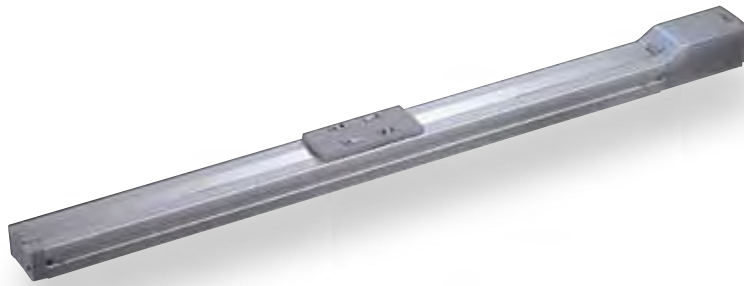

Technical References A-5



- When the stroke increases, the maximum speed will drop to prevent the ball screw from reaching the critical rotational speed. Use the actuator specification table below to check the maximum speed at the stroke you desire.
- Since the RCP2 series use a pulse motor, the load capacity decreases at high speeds. Check in the Speed vs. Load Capacity graph to see if your desired speed and load capacity are supported.
- The load capacity is based on operation at an acceleration of 0.3G (0.2G for the 3mm-lead model, or when used vertically). The maximum acceleration is 0.7G (0.3G when used vertically), however, note that the load capacity decreases at high accelerations. For more information, see the table of load capacity by acceleration, on page A-53.

■ Speed vs. Load Capacity
 Due to the characteristics of the pulse motor, the RCP2 series' load capacity decreases at high speeds. In the table below, check if your desired speed and load capacity are supported.

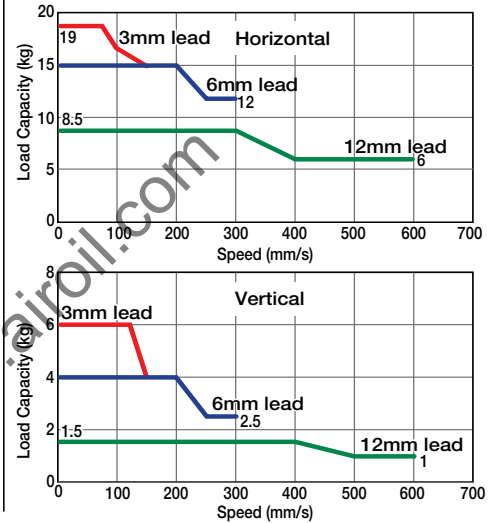

Actuator Specifications

Lead and Load Capacity

(Note 1) Please note that the maximum load capacity decreases as the speed increases.

Stroke and Maximum Speed

Model	Lead (mm)	Max. Load Capacity (Note 1)		Stroke (mm)
		Horizontal (kg)	Vertical (kg)	
RCP2-SA6C-I-42P-12-①-②-③-④	12	~ 8.5	~ 1.5	50 ~ 800 (50mm increments)
RCP2-SA6C-I-42P-6-①-②-③-④	6	~ 15	~ 4	
RCP2-SA6C-I-42P-3-①-②-③-④	3	~ 19	~ 6	

Stroke Lead	50 ~ 550 (50mm increments)	600 (mm)	650 (mm)	700 (mm)	750 (mm)	800 (mm)
12	600	540	460	400	360	300
6	300	270	230	200	180	150
3	150	135	115	100	90	75

Legend ① Stroke ② Compatible controller ③ Cable length ④ Options

(Unit: mm/s)

① Stroke List

Stroke (mm)	Standard Price
50	-
100	-
150	-
200	-
250	-
300	-
350	-
400	-
450	-
500	-
550	-
600	-
650	-
700	-
750	-
800	-

④ Option List

Name	Option Code	See Page	Standard Price
Brake (Cable-exit end)	BE	→ A-25	-
Brake (Cable exiting left)	BL	→ A-25	-
Brake (Cable exiting right)	BR	→ A-25	-
Reversed-home	NM	→ A-33	-
Slider Roller	SR	→ A-36	-

③ Cable List

Type	Cable Symbol	Standard Price
Standard	P (1m)	-
	S (3m)	-
	M (5m)	-
Special Lengths	X06 (6m) ~ X10 (10m)	-
	X11 (11m) ~ X15 (15m)	-
	X16 (16m) ~ X20 (20m)	-
	R01 (1m) ~ R03 (3m)	-
Robot Cable	R04 (4m) ~ R05 (5m)	-
	R06 (6m) ~ R10 (10m)	-
	R11 (11m) ~ R15 (15m)	-
	R16 (16m) ~ R20 (20m)	-

* See page A-39 for cables for maintenance.

Actuator Specifications

Item	Description
Drive System	Ball screw Ø10mm C10 grade
Positioning Repeatability	±0.02mm
Lost Motion	0.1mm or less
Base	Material: Aluminum (special alumite treated)
Allowable Static Moment	Ma: 38.3 N-m Mb: 54.7 N-m Mc: 81.0 N-m
Allowable Dynamic Moment (*)	Ma: 8.9 N-m Mb: 12.7 N-m Mc: 18.6 N-m
Overhang Load Length	Ma direction: 220mm or less; Mb-Mc direction: 220mm or less
Ambient Operating Temp./Humidity	0~40°C, 85% RH or less (Non-condensing)

(*) Based on 5,000km travel life.

Directions of Allowable Load Moments

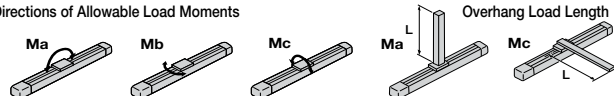

Dimensions

CAD drawings can be downloaded from IAI website. www.intelligentactuator.com

For Special Orders A-9



*For the Reversed-home model, the dimensions (distance to home) on the motor-side and that on the opposite side are flipped.

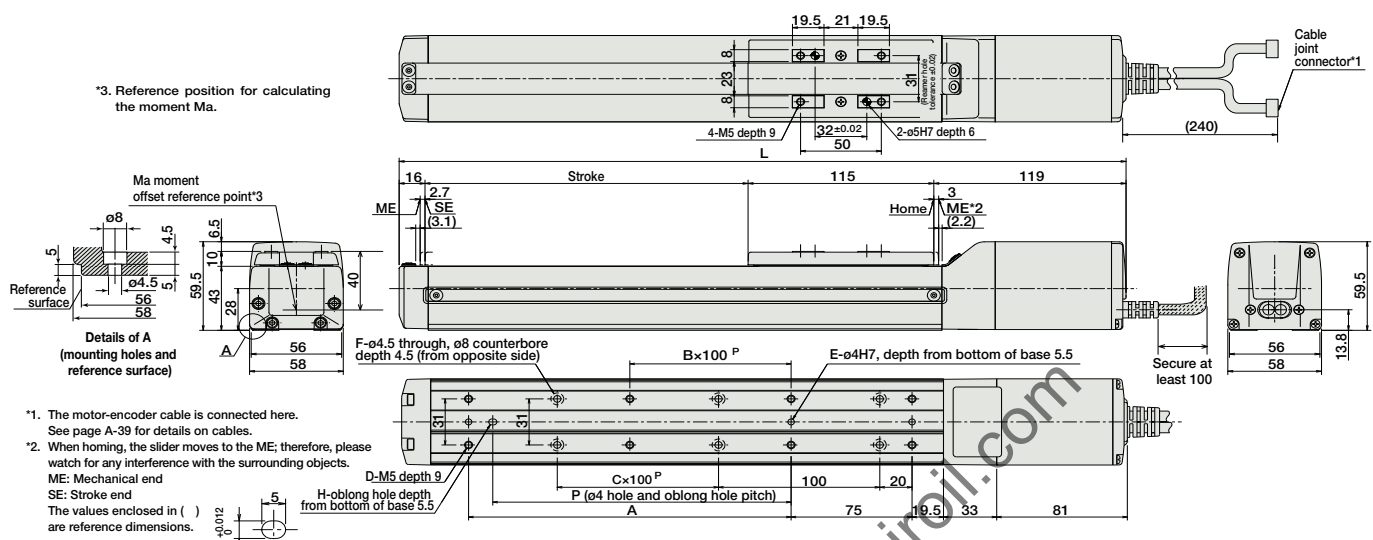

*3. Reference position for calculating the moment M_a .

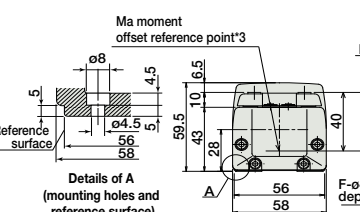

- *1. The motor-encoder cable is connected here. See page A-39 for details on cables.
- *2. When homing, the slider moves to the ME; therefore, please watch for any interference with the surrounding objects.
ME: Mechanical end
SE: Stroke end
The values enclosed in () are reference dimensions.

Dimensions of the brake section

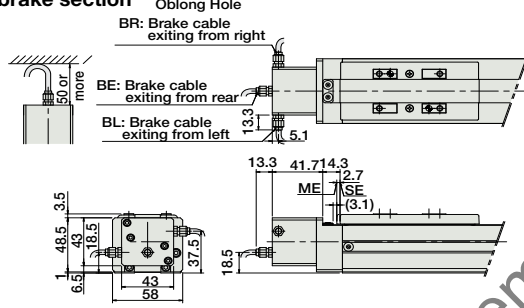

Dimensions/Weight by Stroke

Stroke	50	100	150	200	250	300	350	400	450	500	550	600	650	700	750	800
L	300	350	400	450	500	550	600	650	700	750	800	850	900	950	1000	1050
A	0	100	100	200	200	300	300	400	500	500	600	600	700	700	800	800
B	0	0	0	1	1	2	2	3	3	4	4	5	5	6	6	7
C	0	0	1	1	2	2	3	3	4	4	5	5	6	6	7	7
D	4	6	6	8	8	10	10	12	12	14	14	16	16	18	18	20
E	2	3	3	3	3	3	3	3	3	3	3	3	3	3	3	3
F	4	4	6	6	8	8	10	10	12	12	14	14	16	16	18	18
H	0	1	1	1	1	1	1	1	1	1	1	1	1	1	1	1
P	0	85	85	185	185	285	285	385	385	485	485	585	585	685	685	785
Weight (kg)	1.8	2.0	2.1	2.2	2.4	2.5	2.7	2.8	2.9	3.1	3.2	3.4	3.5	3.6	3.8	3.9

* Adding a brake increases the actuator's overall length by 40mm (63.3mm with the cable coming out its end), and its weight by 0.4kg.

2 Compatible Controllers

The RCP2 series actuators can operate with the controllers below. Select the controller according to your usage.

Name	External View	Model	Description	Max. Positioning Points	Input Voltage	Power Supply Capacity	Standard Price	See Page
Solenoid Valve Type		PMEC-C-42PI-NP-2-①	Easy-to-use controller, even for beginners	3 points	AC100V AC200V	See P481	-	→ P477
		PSEP-C-42PI-NP-2-0-H	Operable with same signal as solenoid valve. Supports both single and double solenoid types. No homing necessary with simple absolute type.					
Splash-Proof Solenoid Valve Type		PSEP-CW-42PI-NP-2-0-H						→ P487
Positioner Type		PCON-C-42PI-NP-2-0-H	Positioning is possible for up to 512 points	512 points	DC24V	2A max.	-	→ P525
Safety-Compliant Positioner Type		PCON-CG-42PI-NP-2-0-H						
Pulse Train Input Type (Differential Line Driver)		PCON-PL-42PI-NP-2-0-H	Pulse train input type with differential line driver support	(-)	DC24V	2A max.	-	→ P525
Pulse Train Input Type (Open Collector)		PCON-PO-42PI-NP-2-0-H	Pulse train input type with open collector support					
Serial Communication Type		PCON-SE-42PI-N-0-0-H	Dedicated to serial communication	64 points				
Field Network Type		RPCON-42P-H	Dedicated to field network	768 points				→ P503
Program Control Type		PSEL-C-1-42PI-NP-2-0-H	Programmed operation is possible. Can operate up to 2 axes	1500 points				→ P557

* This is for the single-axis PSEL.
* ① is a placeholder for the power supply voltage (1: 100V / 2: 100~240V).

RCP2-SA7C

ROBO Cylinder Slider Type 73mm Width Pulse Motor Straight Type Coupled

■ Configuration: **RCP2** — **SA7C** — **I** — **56P** — — — — —

Series — Type — Encoder — Motor — Lead — Stroke — Compatible Controllers — Cable Length — Option

I: Incremental * The Simple absolute encoder models are labeled as "I".
 56P: Pulse motor 56 □ size
 16: 16mm
 8: 8mm
 4: 4mm
 50: 50mm
 800: 800mm (50mm pitch increments)
 P1: PCON
 RPCON
 PSEL
 P3: PMEC
 PSEP
 N: None
 P: 1m
 S: 3m
 M: 5m
 X □: Custom Length
 R □: Robot cable
 BE: Brake (Cable exiting end)
 BL: Brake (Cable exiting left)
 BR: Brake (Cable exiting right)
 NM: Reversed-home
 SR: Slider Roller

* See page Pre-35 for explanation of each code that makes up the configuration name.

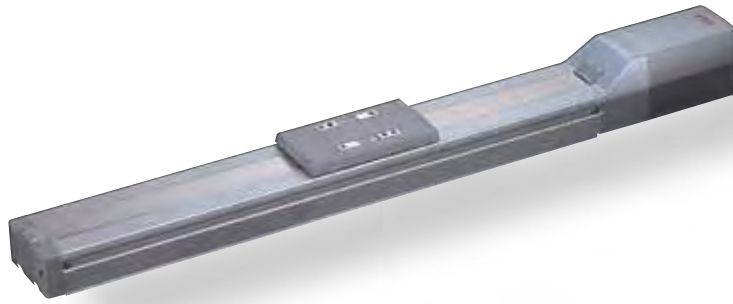

Technical References A-5

- POINT**
Notes on Selection
- When the stroke increases, the maximum speed will drop to prevent the ball screw from reaching the critical rotational speed. Use the actuator specification table below to check the maximum speed at the stroke you desire.
 - Since the RCP2 series use a pulse motor, the load capacity decreases at high speeds. Check in the Speed vs. Load Capacity graph to see if your desired speed and load capacity are supported.
 - The load capacity is based on operation at an acceleration of 0.3G (0.2G for the 4mm-lead model, or when used vertically). These values are the upper limits for the acceleration.

■ Speed vs. Load Capacity
 Due to the characteristics of the pulse motor, the RCP2 series' load capacity decreases at high speeds. In the table below, check if your desired speed and load capacity are supported.

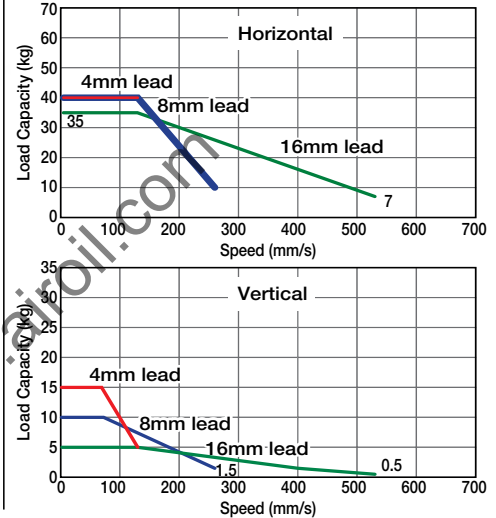

Actuator Specifications				
Lead and Load Capacity		Stroke and Maximum Speed		
Model	Lead (mm)	Max. Load Capacity (Note 1)		Stroke (mm)
		Horizontal (kg)	Vertical (kg)	
RCP2-SA7C-I-56P-16-①-②-③-④	16	~ 35	~ 5	50 ~ 800 (50mm increments)
RCP2-SA7C-I-56P-8-①-②-③-④	8	~ 40	~ 10	
RCP2-SA7C-I-56P-4-①-②-③-④	4	40	~ 15	

Legend ① Stroke ② Compatible controller ③ Cable length ④ Options

Stroke Lead	50 ~ 700 (50mm increments)		~ 800 (mm)
	16	533	480
8	266	240	
4	133	120	

(Unit: mm/s)

① Stroke List

Stroke (mm)	Standard Price
50/100	-
150/200	-
250/300	-
350/400	-
450/500	-
550/600	-
650/700	-
750/800	-

③ Cable List

Type	Cable Symbol	Standard Price
Standard	P (1m)	-
	S (3m)	-
	M (5m)	-
Special Lengths	X06 (6m) ~ X10 (10m)	-
	X11 (11m) ~ X15 (15m)	-
	X16 (16m) ~ X20 (20m)	-
	R01 (1m) ~ R03 (3m)	-
Robot Cable	R04 (4m) ~ R05 (5m)	-
	R06 (6m) ~ R10 (10m)	-
	R11 (11m) ~ R15 (15m)	-
	R16 (16m) ~ R20 (20m)	-

* See page A-39 for cables for maintenance.

④ Option List

Name	Option Code	See Page	Standard Price
Brake (Cable-exit end)	BE	→ A-25	-
Brake (Cable exiting left)	BL	→ A-25	-
Brake (Cable exiting right)	BR	→ A-25	-
Reversed-home	NM	→ A-33	-
Slider Roller	SR	→ A-36	-

Actuator Specifications

Item	Description
Drive System	Ball screw ø12mm C10 grade
Positioning Repeatability	±0.02mm
Lost Motion	0.1mm or less
Base	Material: Aluminum (special alumite treated)
Allowable Static Moment	Ma: 50.4 N-m Mb: 71.9 N-m Mc: 138.0 N-m
Allowable Dynamic Moment (*)	Ma: 13.9 N-m Mb: 19.9 N-m Mc: 38.3 N-m
Overhang Load Length	Ma direction: 230mm or less; Mb-Mc direction: 230mm or less
Ambient Operating Temp./Humidity	0~40°C, 85% RH or less (Non-condensing)

(*) Based on 5,000km travel life.

Directions of Allowable Load Moments

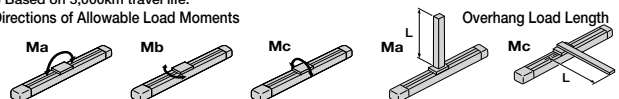

Dimensions

CAD drawings can be downloaded from IAI website. www.intelligentactuator.com

For Special Orders A-9



*For the Reversed-home model, the dimensions (distance to home) on the motor-side and that on the opposite side are flipped.

*3. Reference position for calculating the moment Ma.

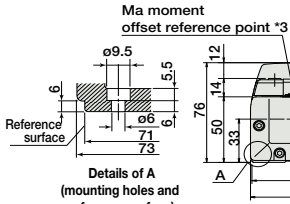

* Adding a brake will increase the actuator's overall length by 43mm (56.3mm with the cable coming out the end), and its weight by 0.6kg.

Dimensions of the brake section

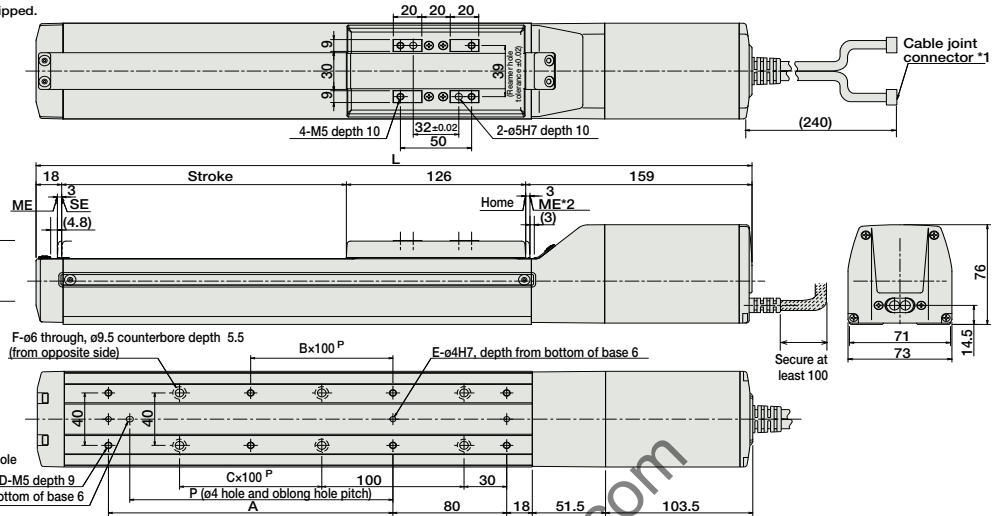
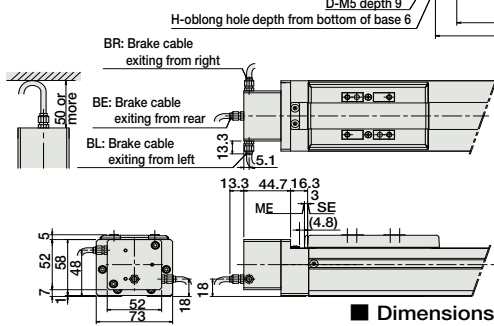

- The motor-encoder cable is connected here. See page A-39 for details on cables.
 - When homing, the slider moves to the ME; therefore, please watch for any interference with the surrounding objects.
- ME: Mechanical end
SE: Stroke end
The values enclosed in "()" are reference dimensions.

Dimensions/Weight by Stroke

Stroke	50	100	150	200	250	300	350	400	450	500	550	600	650	700	750	800
L	353	403	453	503	553	603	653	703	753	803	853	903	953	1003	1053	1103
A	0	100	100	200	200	300	300	400	400	500	500	600	600	700	700	800
B	0	0	0	1	1	2	2	3	3	4	4	5	5	6	6	7
C	0	0	1	1	2	2	3	3	4	4	5	5	6	6	7	7
D	4	6	6	8	8	10	10	12	12	14	14	16	16	18	18	20
E	2	3	3	3	3	3	3	3	3	3	3	3	3	3	3	3
F	4	4	6	6	8	8	10	10	12	12	14	14	16	16	18	18
H	0	1	1	1	1	1	1	1	1	1	1	1	1	1	1	1
P	0	85	85	185	185	285	285	385	385	485	485	585	585	685	685	785
Weight (kg)	3.1	3.3	3.6	3.8	4.0	4.2	4.5	4.7	4.9	5.1	5.4	5.6	5.8	6.0	6.3	6.5

② Compatible Controllers

The RCP2 series actuators can operate with the controllers below. Select the controller according to your usage.

Name	External View	Model	Description	Max. Positioning Points	Input Voltage	Power Supply Capacity	Standard Price	See Page
Solenoid Valve Type		PMEC-C-56PI-NP-2-①	Easy-to-use controller, even for beginners	3 points	AC100V AC200V	See P481	-	→ P477
		PSEP-C-56PI-NP-2-0	Operable with same signal as solenoid valve. Supports both single and double solenoid types. No homing necessary with simple absolute type.					→ P487
Splash-Proof Solenoid Valve Type		PSEP-CW-56PI-NP-2-0						
Positioner Type		PCON-C-56PI-NP-2-0	Positioning is possible for up to 512 points	512 points	DC24V	2A max.	-	→ P525
Safety-Compliant Positioner Type		PCON-CG-56PI-NP-2-0						
Pulse Train Input Type (Differential Line Driver)		PCON-PL-56PI-NP-2-0	Pulse train input type with differential line driver support	(-)	DC24V	2A max.	-	→ P525
Pulse Train Input Type (Open Collector)		PCON-PO-56PI-NP-2-0	Pulse train input type with open collector support					
Serial Communication Type		PCON-SE-56PI-N-0-0	Dedicated to serial communication	64 points			-	
Field Network Type		RPCON-56P	Dedicated to field network	768 points			-	→ P503
Program Control Type		PSEL-C-1-56PI-NP-2-0	Programmed operation is possible. Can operate up to 2 axes	1500 points			-	→ P557

* This is for the single-axis PSEL.

* ① is a placeholder for the power supply voltage (1: 100V / 2: 100~240V).

RCP2-SS7C ROBO Cylinder Slider Type 60mm Width Pulse Motor Straight Type Coupled

■ Configuration: **RCP2** — **SS7C** — **I** — **42P** — — — — —

Series — Type — Encoder — Motor — Lead — Stroke — Compatible Controllers — Cable Length — Option

I: Incremental * The Simple absolute encoder models are labeled as "I".
 42P: Pulse motor 42□ size
 12: 12mm
 6: 6mm
 3: 3mm
 50: 50mm
 600: 600mm (50mm pitch increments)
 P1: PCON
 RPCON
 PSEL
 P3: PMEC
 PSEP
 N: None
 P: 1m
 S: 3m
 M: 5m
 X□□: Custom Length
 R□□: Robot cable
 B: Brake
 NM: Reversed-home
 SR: Slider Roller

* See page Pre-35 for explanation of each code that makes up the configuration name.

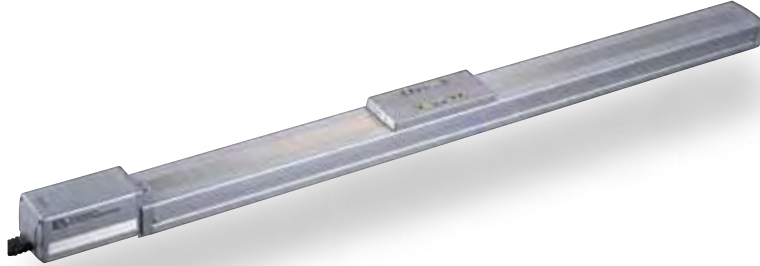

Technical References A-5

- POINT** Notes on Selection
- When the stroke increases, the maximum speed will drop to prevent the ball screw from reaching the critical rotational speed. Use the actuator specification table below to check the maximum speed at the stroke you desire.
 - Since the RCP2 series use a pulse motor, the load capacity decreases at high speeds. Check in the Speed vs. Load Capacity graph to see if your desired speed and load capacity are supported.
 - The load capacity is based on operation at an acceleration of 0.3G (0.2G for the 3mm-lead model, or when used vertically). These values are the upper limits for the acceleration.

■ Speed vs. Load Capacity
 Due to the characteristics of the pulse motor, the RCP2 series' load capacity decreases at high speeds. In the table below, check if your desired speed and load capacity are supported.

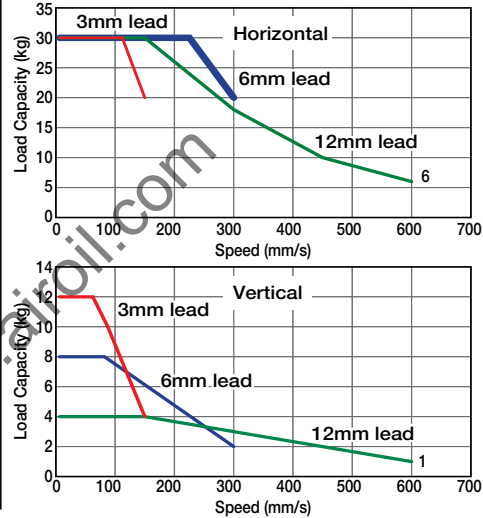

Actuator Specifications								
■ Lead and Load Capacity			(Note 1) Please note that the maximum load capacity decreases as the speed increases.		■ Stroke and Maximum Speed			
Model	Lead (mm)	Max. Load Capacity (Note 1)		Stroke (mm)	Stroke Lead	50 ~ 500 (50mm increments)		~ 600 (mm)
		Horizontal (kg)	Vertical (kg)			600	470	
RCP2-SS7C-I-42P-12-①-②-③-④	12	~ 30	~ 4	50 ~ 600 (50mm increments)	12	600	470	
RCP2-SS7C-I-42P-6-①-②-③-④	6	~ 30	~ 8		6	300	230	
RCP2-SS7C-I-42P-3-①-②-③-④	3	~ 30	~ 12		3	150	115	

Legend ① Stroke ② Compatible controller ③ Cable length ④ Options (Unit: mm/s)

① Stroke List

Stroke (mm)	Standard Price
50/100	-
150/200	-
250/300	-
350/400	-
450/500	-
550/600	-

③ Cable List

Type	Cable Symbol	Standard Price
Standard	P (1m)	-
	S (3m)	-
	M (5m)	-
Special Lengths	X06 (6m) ~ X10 (10m)	-
	X11 (11m) ~ X15 (15m)	-
	X16 (16m) ~ X20 (20m)	-
	R01 (1m) ~ R03 (3m)	-
Robot Cable	R04 (4m) ~ R05 (5m)	-
	R06 (6m) ~ R10 (10m)	-
	R11 (11m) ~ R15 (15m)	-
	R16 (16m) ~ R20 (20m)	-

④ Option List

Name	Option Code	See Page	Standard Price
Brake	B	→ A-25	-
Reversed-home	NM	→ A-33	-
Slider Roller	SR	→ A-36	-

Actuator Specifications

Item	Description
Drive System	Ball screw Ø10mm C10 grade
Positioning Repeatability	±0.02mm
Lost Motion	0.1mm or less
Base	Material: Special alloy steel
Allowable Static Moment	Ma: 79.4 N·m Mb: 79.4 N·m Mc: 172.9 N·m
Allowable Dynamic Moment (*)	Ma: 14.7 N·m Mb: 14.7 N·m Mc: 33.3 N·m
Overhang Load Length	Ma direction: 300mm or less; Mb-Mc direction: 300mm or less
Ambient Operating Temp./Humidity	0~40°C, 85% RH or less (Non-condensing)

(*) Based on 10,000km travel life.
 Directions of Allowable Load Moments

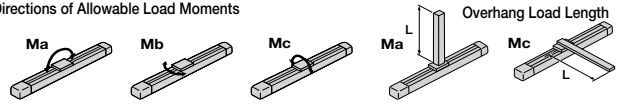

Dimensions

CAD drawings can be downloaded from IAI website. www.intelligentactuator.com

For Special Orders A-9



*For the Reversed-home model, the dimensions (distance to home) on the motor-side and that on the opposite side are flipped.

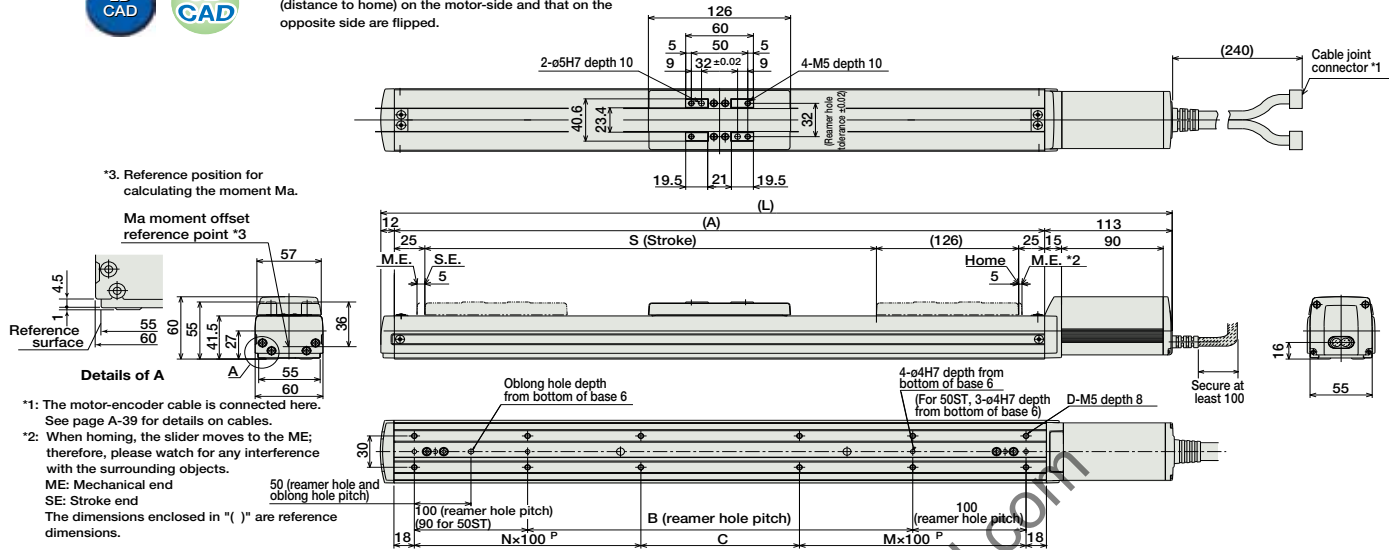

*3. Reference position for calculating the moment Ma.

Ma moment offset reference point *3

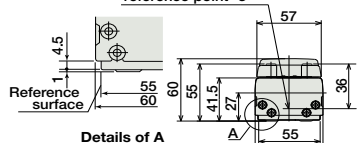

- *1: The motor-encoder cable is connected here. See page A-39 for details on cables.
- *2: When homing, the slider moves to the ME; therefore, please watch for any interference with the surrounding objects.
ME: Mechanical end
SE: Stroke end
The dimensions enclosed in "()" are reference dimensions.

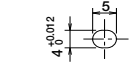

Dimensions of the brake section

* Adding a brake will increase the actuator's overall length by 24.5mm, and its weight by 0.3kg.

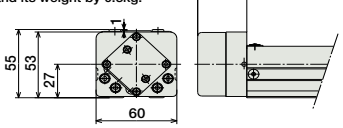

* Brake cable is passed through the actuator body and connected to the motor cable.

■ Dimensions/Weight by Stroke

Stroke	50	100	150	200	250	300	350	400	450	500	550	600
L	351	401	451	501	551	601	651	701	751	801	851	901
A	226	276	326	376	426	476	526	576	626	676	726	776
B	0	40	90	140	190	240	290	340	390	440	490	540
C	90	40	90	140	190	40	90	140	190	40	90	140
D	6	8	8	8	8	12	12	12	12	16	16	16
M	1	1	1	1	1	2	2	2	2	3	3	3
N	0	1	1	1	1	2	2	2	2	3	3	3
Weight (kg)	3.1	3.4	3.7	4.0	4.3	4.7	5.0	5.4	5.7	6.1	6.4	6.7

② Compatible Controllers

The RCP2 series actuators can operate with the controllers below. Select the controller according to your usage.

Name	External View	Model	Description	Max. Positioning Points	Input Voltage	Power Supply Capacity	Standard Price	See Page
Solenoid Valve Type		PMEC-C-42PI-NP-2-①	Easy-to-use controller, even for beginners	3 points	AC100V AC200V	See P481	-	→ P477
		PSEP-C-42PI-NP-2-0	Operable with same signal as solenoid valve. Supports both single and double solenoid types. No homing necessary with simple absolute type.					
Splash-Proof Solenoid Valve Type		PSEP-CW-42PI-NP-2-0						
Positioner Type		PCON-C-42PI-NP-2-0	Positioning is possible for up to 512 points	512 points			-	
Safety-Compliant Positioner Type		PCON-CG-42PI-NP-2-0						
Pulse Train Input Type (Differential Line Driver)		PCON-PL-42PI-NP-2-0	Pulse train input type with differential line driver support	(-)	DC24V	2A max.	-	→ P525
Pulse Train Input Type (Open Collector)		PCON-PO-42PI-NP-2-0	Pulse train input type with open collector support					
Serial Communication Type		PCON-SE-42PI-N-0-0	Dedicated to serial communication	64 points				
Field Network Type		RPCON-42P	Dedicated to field network	768 points				→ P503
Program Control Type		PSEL-C-1-42PI-NP-2-0	Programmed operation is possible. Can operate up to 2 axes	1500 points				→ P557

* This is for the single-axis PSEL.
* ① is a placeholder for the power supply voltage (1: 100V / 2: 100~240V).

RCP2-SS8C

ROBO Cylinder Slider Type 80mm Width Pulse Motor Straight Type Steel Base Coupled

■ Configuration: **RCP2** — **SS8C** — **I** — **56P** — — — — —

Series — Type — Encoder — Motor — Lead — Stroke — Compatible Controllers — Cable Length — Option

I: Incremental * The Simple absolute encoder models are labeled as "I".
 56P: Pulse motor 56 □ size
 20: 20mm 10: 10mm 5: 5mm
 50: 50mm 1000: 1000mm (50mm pitch increments)
 P1: PCON RPCON PSEL P3: PMEC PSEP
 N: None P: 1m S: 3m M: 5m X □ □: Custom Length R □ □: Robot cable
 B: Brake NM: Reversed-home SR: Slider Roller

* See page Pre-35 for explanation of each code that makes up the configuration name.

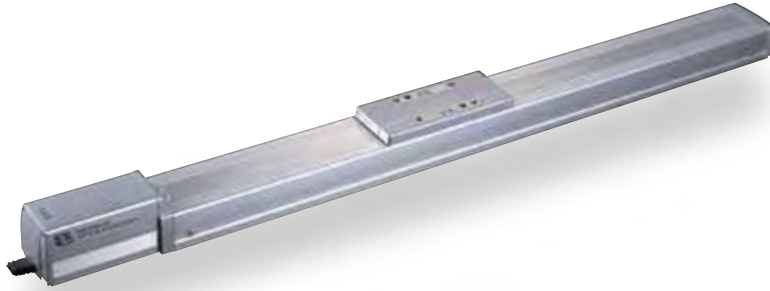

Technical References A-5

- POINT** Notes on Selection
- When the stroke increases, the maximum speed will drop to prevent the ball screw from reaching the critical rotational speed. Use the actuator specification table below to check the maximum speed at the stroke you desire.
 - Since the RCP2 series use a pulse motor, the load capacity decreases at high speeds. Check in the Speed vs. Load Capacity graph to see if your desired speed and load capacity are supported.
 - The load capacity is based on operation at an acceleration of 0.3G (0.2G for the 5mm-lead model, or when used vertically). These values are the upper limits for the acceleration.

■ Speed vs. Load Capacity
 Due to the characteristics of the pulse motor, the RCP2 series' load capacity decreases at high speeds. In the table below, check if your desired speed and load capacity are supported.

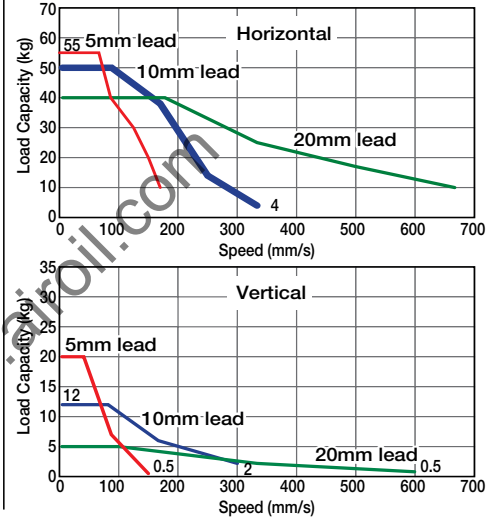

Actuator Specifications

■ Lead and Load Capacity (Note 1) Please note that the maximum load capacity decreases as the speed increases.

Model	Lead (mm)	Max. Load Capacity (Note 1)		Stroke (mm)
		Horizontal (kg)	Vertical (kg)	
RCP2-SS8C-I-56P-20-①-②-③-④	20	~ 40	~ 5	50 ~ 1000 (50mm increments)
RCP2-SS8C-I-56P-10-①-②-③-④	10	~ 50	~ 12	
RCP2-SS8C-I-56P-5-①-②-③-④	5	~ 55	~ 20	

■ Stroke and Maximum Speed

Stroke Lead	50 ~ 800 (50mm increments)	~ 900 (mm)	~ 1000 (mm)
20	666 <600>	625 <600>	515
10	333 <300>	310 <300>	255
5	165 <150>	155 <150>	125

* The values enclosed in < > apply to vertical setting. (Unit: mm/s)

Legend ① Stroke ② Compatible controller ③ Cable length ④ Options

① Stroke List

Stroke (mm)	Standard Price
50/100	-
150/200	-
250/300	-
350/400	-
450/500	-
550/600	-
650/700	-
750/800	-
850/900	-
950/1000	-

③ Cable List

Type	Cable Symbol	Standard Price
Standard	P (1m)	-
	S (3m)	-
	M (5m)	-
Special Lengths	X06 (6m) ~ X10 (10m)	-
	X11 (11m) ~ X15 (15m)	-
	X16 (16m) ~ X20 (20m)	-
Robot Cable	R01 (1m) ~ R03 (3m)	-
	R04 (4m) ~ R05 (5m)	-
	R06 (6m) ~ R10 (10m)	-
	R11 (11m) ~ R15 (15m)	-
	R16 (16m) ~ R20 (20m)	-

* See page A-39 for cables for maintenance.

④ Option List

Name	Option Code	See Page	Standard Price
Brake	B	→ A-25	-
Reversed-home	NM	→ A-33	-
Slider Roller	SR	→ A-36	-

Actuator Specifications

Item	Description
Drive System	Ball screw ø16mm C10 grade
Positioning Repeatability	±0.02mm
Lost Motion	0.1mm or less
Base	Material: Special alloy steel
Allowable Static Moment	Ma: 198.9 N·m Mb: 198.9 N·m Mc: 416.7 N·m
Allowable Dynamic Moment (*)	Ma: 36.3 N·m Mb: 36.3 N·m Mc: 77.4 N·m
Overhang Load Length	Ma direction: 450mm or less; Mb-Mc direction: 450mm or less
Ambient Operating Temp./Humidity	0~40°C, 85% RH or less (Non-condensing)

(*) Based on 10,000km travel life.

Directions of Allowable Load Moments

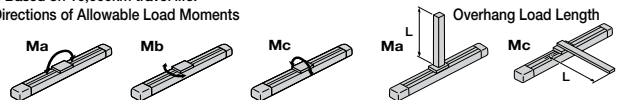

Dimensions

CAD drawings can be downloaded from IAI website. www.intelligentactuator.com

For Special Orders A-9



*For the reversed-home model, the dimensions (distance to home) on the motor-side and that on the opposite side are flipped.

*3. Reference position for calculating the moment Ma.

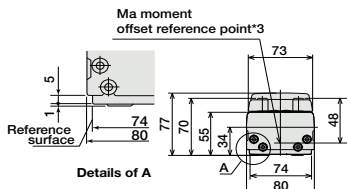

- *1: The motor-encoder cable is connected here. See page A-39 for details on cables.
- *2: When homing, the slider moves to the ME; therefore, please watch for any interference with the surrounding objects.
ME: Mechanical end
SE: Stroke end
The dimensions enclosed in "()" are reference dimensions.

Dimensions of the brake section

* Adding a brake will increase the actuator's overall length by 26mm, and its weight by 0.5kg.

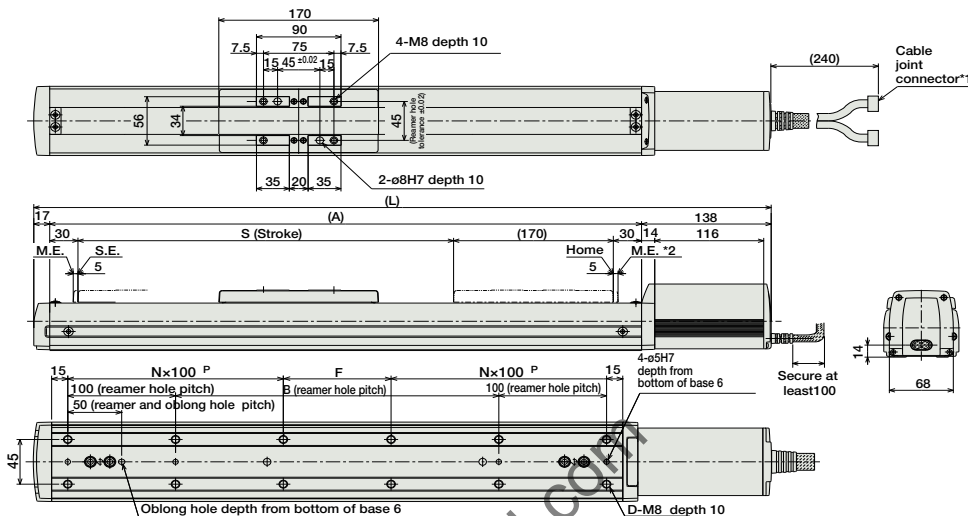
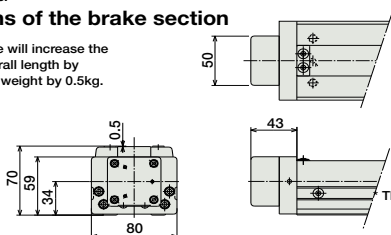

www.airoil.com

■ Dimensions/Weight by Stroke

Stroke	50	100	150	200	250	300	350	400	450	500	550	600	650	700	750	800	850	900	950	1000
L	435	485	535	585	635	685	735	785	835	885	935	985	1035	1085	1135	1185	1235	1285	1335	1385
A	280	330	380	430	480	530	580	630	680	730	780	830	880	930	980	1030	1080	1130	1180	1230
B	50	100	150	200	250	300	350	400	450	500	550	600	650	700	750	800	850	900	950	1000
D	8	8	8	10	12	12	12	14	16	16	16	18	20	20	20	22	24	24	24	26
F	50	100	150	0	50	100	150	0	50	100	150	0	50	100	150	0	50	100	150	0
N	1	1	1	2	2	2	2	3	3	3	3	4	4	4	4	5	5	5	5	6
Weight (kg)	6.6	7.1	7.6	8.1	8.6	9.2	9.7	10.2	10.7	11.3	11.7	12.3	12.8	13.4	13.9	14.5	15.0	15.5	16.1	16.6

② Compatible Controllers

The RCP2 series actuators can operate with the controllers below. Select the controller according to your usage.

Name	External View	Model	Description	Max. Positioning Points	Input Voltage	Power Supply Capacity	Standard Price	See Page
Solenoid Valve Type		PMEC-C-56PI-NP-2-①	Easy-to-use controller, even for beginners	3 points	AC100V AC200V	See P481	-	→ P477
		PSEP-C-56PI-NP-2-0	Operable with same signal as solenoid valve. Supports both single and double solenoid types. No homing necessary with simple absolute type.					
Splash-Proof Solenoid Valve Type		PSEP-CW-56PI-NP-2-0					-	→ P487
Positioner Type		PCON-C-56PI-NP-2-0	Positioning is possible for up to 512 points	512 points			-	
Safety-Compliant Positioner Type		PCON-CG-56PI-NP-2-0						
Pulse Train Input Type (Differential Line Driver)		PCON-PL-56PI-NP-2-0	Pulse train input type with differential line driver support	(-)	DC24V	2A max.	-	→ P525
Pulse Train Input Type (Open Collector)		PCON-PO-56PI-NP-2-0	Pulse train input type with open collector support					
Serial Communication Type		PCON-SE-56PI-N-0-0	Dedicated to serial communication	64 points			-	
Field Network Type		RPCON-56P	Dedicated to field network	768 points			-	→ P503
Program Control Type		PSEL-C-1-56PI-NP-2-0	Programmed operation is possible Can operate up to 2 axes	1500 points			-	→ P557

* This is for the single-axis PSEL.
① is a placeholder for the power supply voltage (1: 100V / 2: 100~240V).

- Slider Type
- Mini
- Standard
- Controllers Integrated
- Rod Type
- Mini
- Standard
- Controllers Integrated
- Table/Arm/Flat Type
- Mini
- Standard
- Gripper/Rotary Type
- Linear Servo Type
- Cleanroom Type
- Splash-Proof
- Controllers
- PMEC/AMEC
- PSEP/ASEP
- ROBO NET
- ERC2
- PCON
- ACON
- SCON
- PSEL
- ASEL
- SSEL
- XSEL
- Pulse Motor
- Servo Motor (24V)
- Servo Motor (200V)
- Linear Servo Motor

RCP2-HS8C

ROBO Cylinder High-Speed Slider Type 80mm Width Pulse Motor Straight Type
Steel Base Coupled

■ Configuration: **RCP2** — **HS8C** — **I** — **86P** — — — **P2** — —

Series — Type — Encoder — Motor — Lead — Stroke — Compatible Controllers — Cable Length — Option

I: Incremental 86P: Pulse motor 56 high output 30:30mm 50: 50mm 1000:1000mm (50mm pitch increments) P2:PCON-CF N : None B : Brake
P : 1m S : 3m M : 5m X : Custom Length R : Robot cable
NM: Reversed-home SR : Slider Roller

* See page Pre-35 for explanation of each code that makes up the configuration name.

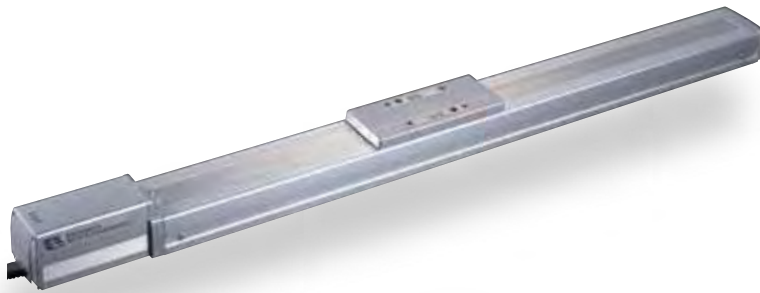

Technical References A-5

- POINT** Notes on Selection
- (1) Due to the large lead of the ball screw in high-speed actuators, operating at low speeds may cause vibration and/or noise. Therefore, use the actuator at speeds over 100mm/s.
 - (2) When the stroke increases, the maximum speed will drop to prevent the ball screw from reaching the critical rotational speed. Use the actuator specification table below to check the maximum speed at the stroke you desire.
 - (3) Since the RCP2 series use a pulse motor, the load capacity decreases at high speeds. Check in the Speed vs. Load Capacity graph to see if your desired speed and load capacity are supported.
 - (4) The load capacity is based on operation at an acceleration of 0.3G (0.2G when used vertically). The upper limit for the acceleration is 0.5G for horizontal use and 0.2G for vertical use.

■ Speed vs. Load Capacity
Due to the characteristics of the pulse motor, the RCP2 series' load capacity decreases at high speeds. In the table below, check if your desired speed and load capacity are supported.

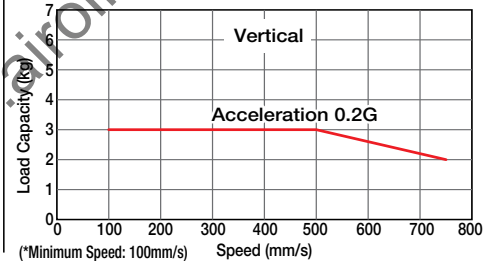
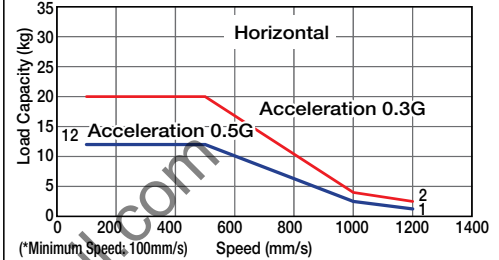

Actuator Specifications

Lead and Load Capacity

(Note 1) Please note that the maximum load capacity decreases as the speed increases.

Model	Lead (mm)	Max. Load Capacity (Note 1)		Stroke (mm)
		Horizontal (kg)	Vertical (kg)	
RCP2-HS8C-I-86P-30-①-P2-②-③	30	~ 20	~ 3	50 ~ 1000 (50mm increments)

Legend ① Stroke ② Cable length ③ Options

Stroke and Maximum Speed

Stroke / Lead	50 ~ 800 (50mm increments)	~ 900 (mm)	~ 1000 (mm)
	30	1200 <750>	1000 <750>

* The values enclosed in < > apply to vertical setting. (Unit: mm/s)

① Stroke List

Stroke (mm)	Standard Price
50/100	-
150/200	-
250/300	-
350/400	-
450/500	-
550/600	-
650/700	-
750/800	-
850/900	-
950/1000	-

② Cable List

Type	Cable Symbol	Standard Price
Standard	P (1m)	-
	S (3m)	-
	M (5m)	-
Special Lengths	X06 (6m) ~ X10 (10m)	-
	X11 (11m) ~ X15 (15m)	-
	X16 (16m) ~ X20 (20m)	-
	R01 (1m) ~ R03 (3m)	-
Robot Cable	R04 (4m) ~ R05 (5m)	-
	R06 (6m) ~ R10 (10m)	-
	R11 (11m) ~ R15 (15m)	-
	R16 (16m) ~ R20 (20m)	-

* See page A-39 for cables for maintenance.

③ Option List

Name	Option Code	See Page	Standard Price
Brake	B	→ A-25	-
Reversed-home	NM	→ A-33	-
Slider Roller	SR	→ A-36	-

Actuator Specifications

Item	Description
Drive System	Ball screw ϕ 16mm C10 grade
Positioning Repeatability	\pm 0.02mm
Lost Motion	0.1mm or less
Base	Material: Special alloy steel
Allowable Static Moment	Ma: 198.9 N·m Mb: 198.9 N·m Mc: 416.7 N·m
Allowable Dynamic Moment (*)	Ma: 36.3 N·m Mb: 36.3 N·m Mc: 77.4 N·m
Overhang Load Length	Ma direction: 450mm or less; Mb-Mc direction: 450mm or less
Ambient Operating Temp./Humidity	0~40°C, 85% RH or less (Non-condensing)

(*) Based on 10,000km travel life.

Directions of Allowable Load Moments

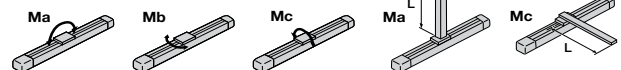

Dimensions

CAD drawings can be downloaded from IAI website. www.intelligentactuator.com

For Special Orders A-9



* For the reversed-home model, the dimensions (distance to home) on the motor-side and that on the opposite side are flipped.

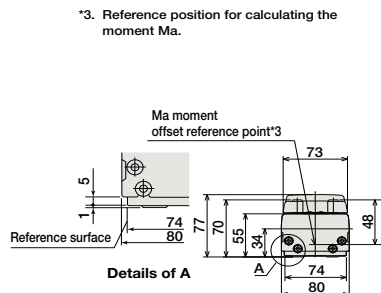

*1: The motor-encoder cable is connected here. See page A-39 for details on cables.
 *2: When homing, the slider moves to the ME; therefore, please watch for any interference with the surrounding objects.
 ME: Mechanical end
 SE: Stroke end
 The dimensions enclosed in "()" are reference dimensions.

Dimensions of the brake section

* Adding a brake will increase the actuator's overall length by 26mm, and its weight by 0.5kg.

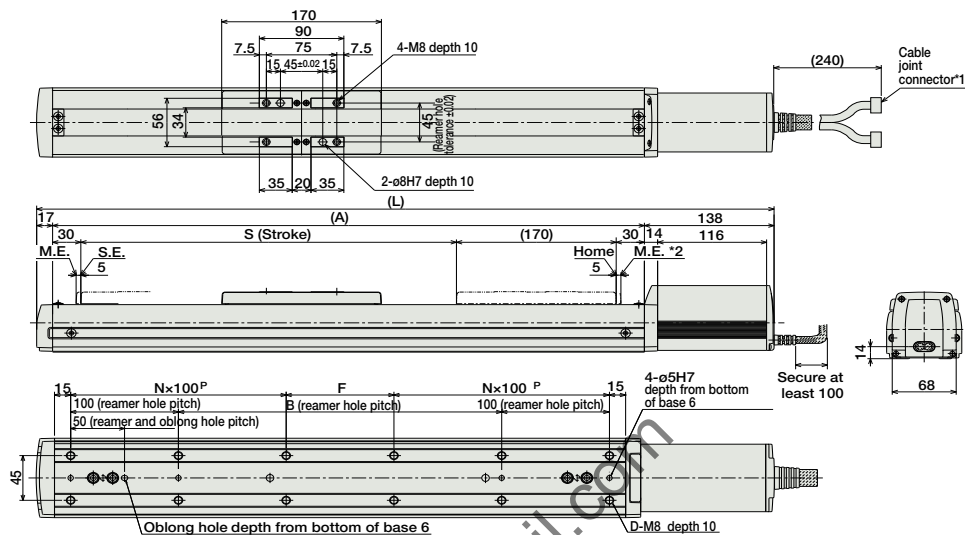
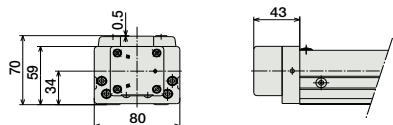

* The brake cable is passed through the actuator body and connected to the motor cable.

■ Dimensions/Weight by Stroke

Stroke	50	100	150	200	250	300	350	400	450	500	550	600	650	700	750	800	850	900	950	1000
L	435	485	535	585	635	685	735	785	835	885	935	985	1035	1085	1135	1185	1235	1285	1335	1385
A	280	330	380	430	480	530	580	630	680	730	780	830	880	930	980	1030	1080	1130	1180	1230
B	50	100	150	200	250	300	350	400	450	500	550	600	650	700	750	800	850	900	950	1000
D	8	8	8	10	12	12	12	14	16	16	16	18	20	20	20	22	24	24	24	26
F	50	100	150	0	50	100	150	0	50	100	150	0	50	100	150	0	50	100	150	0
N	1	1	1	2	2	2	2	3	3	3	3	4	4	4	4	5	5	5	5	6
Weight (kg)	6.6	7.1	7.6	8.1	8.6	9.2	9.7	10.2	10.7	11.3	11.7	12.3	12.8	13.4	13.9	14.5	15.0	15.5	16.1	16.6

Compatible Controllers

The controller for the RCP2-HS8C type is a dedicated controller.

Name	External View	Model	Description	Max. Positioning Points	Input Voltage	Power Supply Capacity	Standard Price	See Page
Positioner Type		PCON-CF-86PI-NP-2-0	Positioning is possible for up to 512 points	512 points	DC24V	6A max.	-	→ P525

Note:

- Please note that the encoder cable is a dedicated CF-type cable that is different from the PCON-C/CG/CY/PL/PO/SE controllers.
- Note that a simple absolute unit cannot be used.

- Slider Type
- Mini
- Standard
- Controllers Integrated
- Rod Type
- Mini
- Standard
- Controllers Integrated
- Table/Arm/Flat Type
- Mini
- Standard
- Gripper/Rotary Type
- Linear Servo Type
- Cleanroom Type
- Splash-Proof
- Controllers
- PMEC/AMEC
- PSEP/ASEP
- ROBO NET
- ERC2
- PCON
- ACON
- SCON
- PSEL
- ASEL
- SSEL
- XSEL
- Pulse Motor
- Servo Motor (24V)
- Servo Motor (200V)
- Linear Servo Motor

RCP2-SA5R

ROBO Cylinder Slider Type 52mm Width Pulse Motor Side-Mounted Motor

■ Configuration: **RCP2** — **SA5R** — **I** — **42P** — — — — —

Series — Type — Encoder — Motor — Lead — Stroke — Compatible Controllers — Cable Length — Option

I: Incremental * The Simple absolute encoder models are labeled as "I".
 42P: Pulse motor 42 □ size
 12: 12mm
 6: 6mm
 3: 3mm
 50: 50mm
 800: 800mm (50mm pitch increments)
 P1: PCON
 RPCON
 PSEL
 P3: PMEC
 PSEP
 N: None
 P: 1m
 S: 3m
 M: 5m
 X □ □: Custom Length
 R □ □: Robot cable

See Options below
 * Be sure to specify which side the motor is to be mounted (ML/MR).

* See page Pre-35 for explanation of each code that makes up the configuration name.



Pictured: Left-mounted motor model (ML).

Technical References A-5

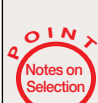

- When the stroke increases, the maximum speed will drop to prevent the ball screw from reaching the critical rotational speed. Use the actuator specification table below to check the maximum speed at the stroke you desire.
- Since the RCP2 series use a pulse motor, the load capacity decreases at high speeds. Check in the Speed vs. Load Capacity graph to see if your desired speed and load capacity are supported.
- The load capacity is based on operation at an acceleration of 0.3G (0.2G for the 3mm-lead model, or when used vertically). These values are the upper limits for the acceleration.

Speed vs. Load Capacity

Due to the characteristics of the pulse motor, the RCP2 series' load capacity decreases at high speeds. In the table below, check if your desired speed and load capacity are supported.

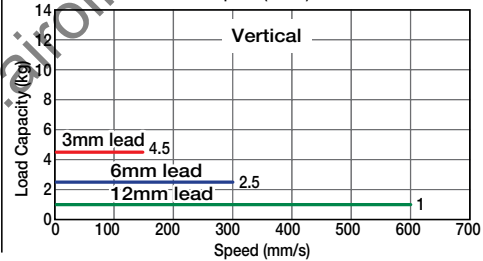
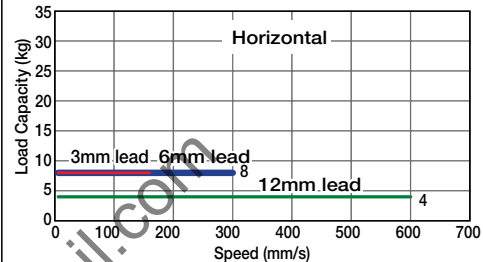

Actuator Specifications

Lead and Load Capacity

(Note 1) Please note that the maximum load capacity decreases as the speed increases.

Stroke and Maximum Speed

Model	Lead (mm)	Max. Load Capacity (Note 1)		Stroke (mm)
		Horizontal (kg)	Vertical (kg)	
RCP2-SA5R-I-42P-12-①-②-③-④	12	4	1	50 ~ 800 (50mm increments)
RCP2-SA5R-I-42P-6-①-②-③-④	6	8	2.5	
RCP2-SA5R-I-42P-3-①-②-③-④	3	8	4.5	

Stroke Lead	50 ~ 550 (50mm increments)	600 (mm)	650 (mm)	700 (mm)	750 (mm)	800 (mm)
12	600	540	460	400	360	300
6	300	270	230	200	180	150
3	150	135	115	100	90	75

Legend ① Stroke ② Compatible controller ③ Cable length ④ Options

(Unit: mm/s)

① Stroke List

Stroke (mm)	Standard Price
50	-
100	-
150	-
200	-
250	-
300	-
350	-
400	-
450	-
500	-
550	-
600	-
650	-
700	-
750	-
800	-

④ Option List

Name	Option Code	See Page	Standard Price
Brake	B	→ A-25	-
Reversed-home	NM	→ A-33	-
Left-Mounted Motor (Standard)	ML	→ A-33	-
Right-Mounted Motor	MR	→ A-33	-
Slider Roller	SR	→ A-36	-

③ Cable List

Type	Cable Symbol	Standard Price
Standard	P (1m)	-
	S (3m)	-
	M (5m)	-
Special Lengths	X06 (6m) ~ X10 (10m)	-
	X11 (11m) ~ X15 (15m)	-
	X16 (16m) ~ X20 (20m)	-
	R01 (1m) ~ R03 (3m)	-
Robot Cable	R04 (4m) ~ R05 (5m)	-
	R06 (6m) ~ R10 (10m)	-
	R11 (11m) ~ R15 (15m)	-
	R16 (16m) ~ R20 (20m)	-

* See page A-39 for cables for maintenance.

Actuator Specifications

Item	Description
Drive System	Ball screw Ø10mm C10 grade
Positioning Repeatability	±0.02mm
Lost Motion	0.1mm or less
Base	Material: Aluminum (white alumite treated)
Allowable Static Moment	Ma: 18.6 N·m Mb: 26.6 N·m Mc: 47.5 N·m
Allowable Dynamic Moment (*)	Ma: 4.9 N·m Mb: 6.8 N·m Mc: 11.7 N·m
Overhang Load Length	Ma direction: 150mm or less; Mb-Mc direction: 150mm or less
Ambient Operating Temp./Humidity	0~40°C, 85% RH or less (Non-condensing)

(*) Based on 5,000km travel life.

Directions of Allowable Load Moments

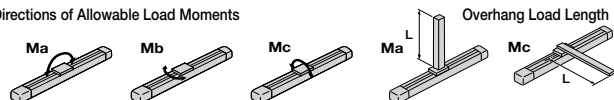

Dimensions

CAD drawings can be downloaded from IAI website. www.intelligentactuator.com

For Special Orders A-9



*For the reversed-home model, the dimensions (distance to home) on the motor-side and that on the opposite side are flipped.

- *1. The motor-encoder cable is connected here. See page A-39 for details on cables.
- *2. When homing, the slider moves to the ME; therefore, please watch for any interference with the surrounding objects.
ME: Mechanical end
SE: Stroke end
The values enclosed in "()" are reference dimensions.

* The offset reference position for the moment Ma is the same as the SA5 type. (See P28)

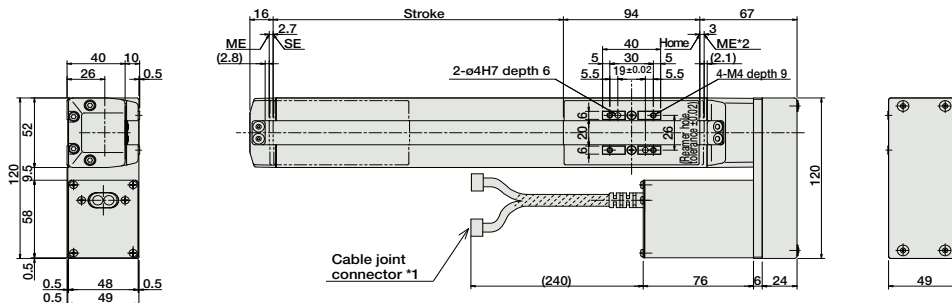

Dimensions of the brake section

* Adding a brake will increase the actuator's overall length by 40mm, and its weight by 0.4kg.

Mounting direction: symmetrically opposite

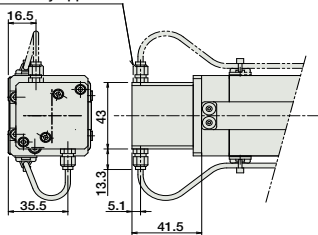

* For brake cable exiting from the side, it can only exit from the motor side.

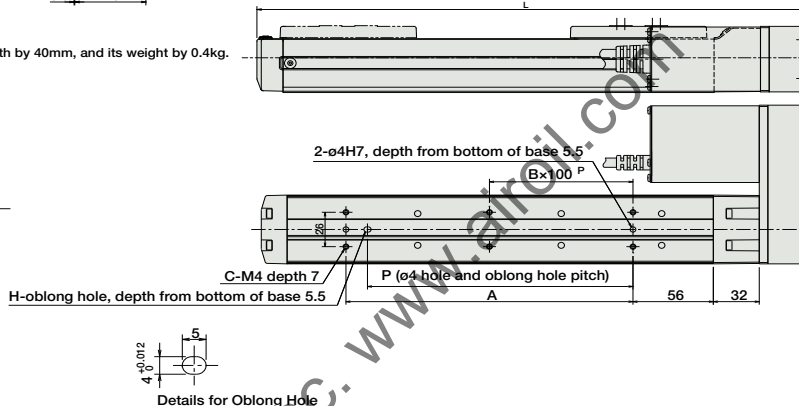

■ Dimensions/Weight by Stroke

Stroke	50	100	150	200	250	300	350	400	450	500	550	600	650	700	750	800
L	227	277	327	377	427	477	527	577	627	677	727	777	827	877	927	977
A	73	100	100	200	200	300	300	400	400	500	500	600	600	700	700	800
B	0	0	0	1	1	2	2	3	3	4	4	5	5	6	6	7
C	4	4	4	6	6	8	8	10	10	12	12	14	14	16	16	18
H	0	1	1	1	1	1	1	1	1	1	1	1	1	1	1	1
P	0	85	85	185	185	285	285	385	385	485	485	585	585	685	685	785
Weight (kg)	2.0	2.1	2.2	2.3	2.4	2.6	2.7	2.8	2.9	3.0	3.1	3.3	3.4	3.5	3.6	3.7

② Compatible Controllers

The RCP2 series actuators can operate with the controllers below. Select the controller according to your usage.

Name	External View	Model	Description	Max. Positioning Points	Input Voltage	Power Supply Capacity	Standard Price	See Page
Solenoid Valve Type		PMEC-C-42PI-NP-2-①	Easy-to-use controller, even for beginners	3 points	AC100V AC200V	See P481	-	→ P477
		PSEP-C-42PI-NP-2-0	Operable with same signal as solenoid valve. Supports both single and double solenoid types. No homing necessary with simple absolute type.					
Splash-Proof Solenoid Valve Type		PSEP-CW-42PI-NP-2-0						
Positioner Type		PCON-C-42PI-NP-2-0	Positioning is possible for up to 512 points	512 points	DC24V	2A max.	-	→ P525
Safety-Compliant Positioner Type		PCON-CG-42PI-NP-2-0						
Pulse Train Input Type (Differential Line Driver)		PCON-PL-42PI-NP-2-0	Pulse train input type with differential line driver support	(-)	DC24V	2A max.	-	→ P525
Pulse Train Input Type (Open Collector)		PCON-PO-42PI-NP-2-0	Pulse train input type with open collector support					
Serial Communication Type		PCON-SE-42PI-N-0-0	Dedicated to serial communication	64 points				
Field Network Type		RPCON-42P	Dedicated to field network	768 points				→ P503
Program Control Type		PSEL-C-1-42PI-NP-2-0	Programmed operation is possible. Can operate up to 2 axes	1500 points				→ P557

* This is for the single-axis PSEL.

* ① is a placeholder for the power supply voltage (1: 100V / 2: 100~240V).

- Slider Type
- Mini
- Standard
- Controllers Integrated
- Rod Type
- Mini
- Standard
- Controllers Integrated
- Table/Arm/Flat Type
- Mini
- Standard
- Controllers Integrated
- Gripper/Rotary Type
- Linear Servo Type
- Cleanroom Type
- Splash-Proof
- Controllers
- PMEC/AMEC
- PSEP/ASEP
- ROBO NET
- ERC2
- PCON
- ACON
- SCON
- PSEL
- ASEL
- SSEL
- XSEL
- Pulse Motor
- Servo Motor (24V)
- Servo Motor (200V)
- Linear Servo Motor

RCP2-SA6R ROBO Cylinder Slider Type 58mm Width Pulse Motor Side-Mounted Motor

■ Configuration: **RCP2** — **SA6R** — **I** — **42P** — — — — —

Series — Type — Encoder — Motor — Lead — Stroke — Compatible Controllers — Cable Length — Option

I: Incremental
* The Simple absolute encoder models are labeled as "I".

42P: Pulse motor 42 □ size

12: 12mm
6: 6mm
3: 3mm

50: 50mm
800: 800mm (50mm pitch increments)

P1: PCON
RPCON
PSEL
P3: PMEC
PSEP

N: None
P: 1m
S: 3m
M: 5m
X □ □: Custom Length
R □ □: Robot cable

See Options below
* Be sure to specify which side the motor is to be mounted (ML/MR).

* See page Pre-35 for explanation of each code that makes up the configuration name.

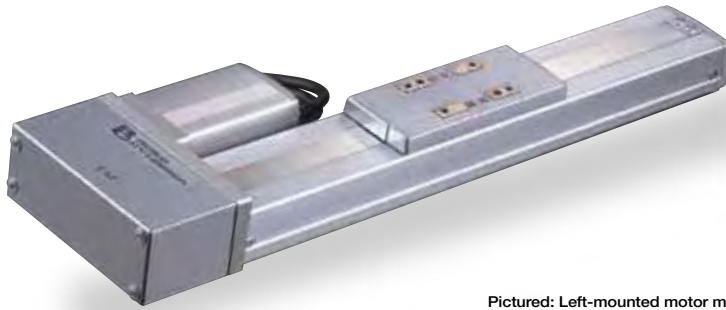

Pictured: Left-mounted motor model (ML).

Technical References A-5



- When the stroke increases, the maximum speed will drop to prevent the ball screw from reaching the critical rotational speed. Use the actuator specification table below to check the maximum speed at the stroke you desire.
- Since the RCP2 series use a pulse motor, the load capacity decreases at high speeds. Check in the Speed vs. Load Capacity graph to see if your desired speed and load capacity are supported.
- The load capacity is based on operation at an acceleration of 0.3G (0.2G for the 3mm-lead model, or when used vertically). These values are the upper limits for the acceleration.

Speed vs. Load Capacity

Due to the characteristics of the pulse motor, the RCP2 series' load capacity decreases at high speeds. In the table below, check if your desired speed and load capacity are supported.

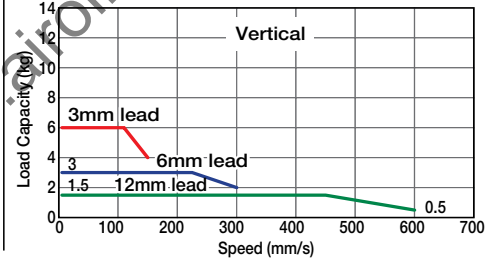
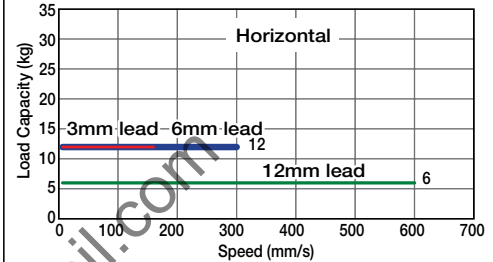

Actuator Specifications

Lead and Load Capacity

(Note 1) Please note that the maximum load capacity decreases as the speed increases.

Stroke and Maximum Speed

Model	Lead (mm)	Max. Load Capacity (Note 1)		Stroke (mm)
		Horizontal (kg)	Vertical (kg)	
RCP2-SA6R-I-42P-12-①-②-③-④	12	6	~ 1.5	50 ~ 800 (50mm increments)
RCP2-SA6R-I-42P-6-①-②-③-④	6	12	~ 3	
RCP2-SA6R-I-42P-3-①-②-③-④	3	12	~ 6	

Stroke Lead	50 ~ 550 (50mm increments)	600 (mm)	650 (mm)	700 (mm)	750 (mm)	800 (mm)
12	600	540	460	400	360	300
6	300	270	230	200	180	150
3	150	135	115	100	90	75

Legend ① Stroke ② Compatible controller ③ Cable length ④ Options

(Unit: mm/s)

① Stroke List

Stroke (mm)	Standard Price
50	-
100	-
150	-
200	-
250	-
300	-
350	-
400	-
450	-
500	-
550	-
600	-
650	-
700	-
750	-
800	-

④ Option List

Name	Option Code	See Page	Standard Price
Brake	B	→ A-25	-
Reversed-home	NM	→ A-33	-
Left-Mounted Motor (Standard)	ML	→ A-33	-
Right-Mounted Motor	MR	→ A-33	-
Slider Roller	SR	→ A-36	-

③ Cable List

Type	Cable Symbol	Standard Price
Standard	P (1m)	-
	S (3m)	-
	M (5m)	-
Special Lengths	X06 (6m) ~ X10 (10m)	-
	X11 (11m) ~ X15 (15m)	-
	X16 (16m) ~ X20 (20m)	-
	R01 (1m) ~ R03 (3m)	-
Robot Cable	R04 (4m) ~ R05 (5m)	-
	R06 (6m) ~ R10 (10m)	-
	R11 (11m) ~ R15 (15m)	-
	R16 (16m) ~ R20 (20m)	-

* See page A-39 for cables for maintenance.

Actuator Specifications

Item	Description
Drive System	Ball screw Ø10mm C10 grade
Positioning Repeatability	±0.02mm
Lost Motion	0.1mm or less
Base	Material: Aluminum (white alumite treated)
Allowable Static Moment	Ma: 38.3 N·m Mb: 54.7 N·m Mc: 81.0 N·m
Allowable Dynamic Moment (*)	Ma: 8.9 N·m Mb: 12.7 N·m Mc: 18.6 N·m
Overhang Load Length	Ma direction: 220mm or less; Mb-Mc direction: 220mm or less
Ambient Operating Temp./Humidity	0~40°C, 85% RH or less (Non-condensing)

(*) Based on 5,000km travel life.

Directions of Allowable Load Moments

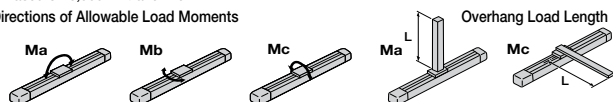

Dimensions

CAD drawings can be downloaded from IAI website. www.intelligentactuator.com

For Special Orders A-9



*For the reversed-home model, the dimensions (distance to home) on the motor-side and that on the opposite side are flipped.

- The motor-encoder cable is connected here. See page A-39 for details on cables.
- When homing, the slider moves to the ME; therefore, please watch for any interference with the surrounding objects.
ME: Mechanical end
SE: Stroke end
The values enclosed in "()" are reference dimensions.

*The offset reference position for the moment Ma is the same as the SA6 type. (See P30)

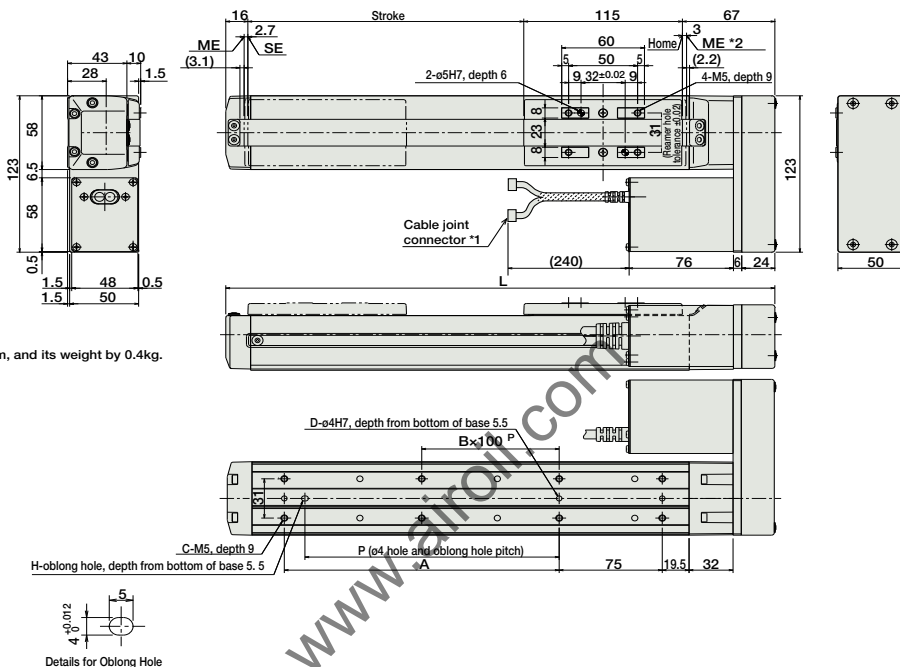

Dimensions of the brake section

* Adding a brake will increase the actuator's overall length by 40mm, and its weight by 0.4kg.

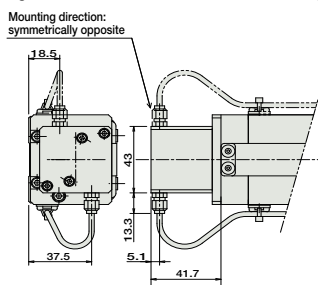

* For brake cable exiting from the side, it can only exit from the motor side.

■ Dimensions/Weight by Stroke

Stroke	50	100	150	200	250	300	350	400	450	500	550	600	650	700	750	800
L	248	298	348	398	448	498	548	598	648	698	748	798	848	898	948	998
A	0	100	100	200	200	300	300	400	400	500	500	600	600	700	700	800
B	0	0	0	1	1	2	2	3	3	4	4	5	5	6	6	7
C	4	6	6	8	8	10	10	12	12	14	14	16	16	18	18	20
D	2	3	3	3	3	3	3	3	3	3	3	3	3	3	3	3
H	0	1	1	1	1	1	1	1	1	1	1	1	1	1	1	1
P	0	85	85	185	185	285	285	385	385	485	485	585	585	685	685	785
Weight (kg)	2.3	2.5	2.6	2.7	2.9	3.0	3.2	3.3	3.4	3.6	3.7	3.9	4.0	4.1	4.3	4.4

② Compatible Controllers

The RCP2 series actuators can operate with the controllers below. Select the controller according to your usage.

Name	External View	Model	Description	Max. Positioning Points	Input Voltage	Power Supply Capacity	Standard Price	See Page
Solenoid Valve Type		PMEC-C-42PI-NP-2-①	Easy-to-use controller, even for beginners	3 points	AC100V AC200V	See P481	-	→ P477
		PSEP-C-42PI-NP-2-0	Operable with same signal as solenoid valve. Supports both single and double solenoid types. No homing necessary with simple absolute type.					
Splash-Proof Solenoid Valve Type		PSEP-CW-42PI-NP-2-0						
Positioner Type		PCON-C-42PI-NP-2-0	Positioning is possible for up to 512 points	512 points			-	
Safety-Compliant Positioner Type		PCON-CG-42PI-NP-2-0						
Pulse Train Input Type (Differential Line Driver)		PCON-PL-42PI-NP-2-0	Pulse train input type with differential line driver support	(-)	DC24V	2A max.	-	→ P525
Pulse Train Input Type (Open Collector)		PCON-PO-42PI-NP-2-0	Pulse train input type with open collector support					
Serial Communication Type		PCON-SE-42PI-N-0-0	Dedicated to serial communication	64 points				
Field Network Type		RPCON-42P	Dedicated to field network	768 points				→ P503
Program Control Type		PSEL-C-1-42PI-NP-2-0	Programmed operation is possible. Can operate up to 2 axes	1500 points				→ P557

* This is for the single-axis PSEL.

* ① is a placeholder for the power supply voltage (1: 100V / 2: 100~240V).

RCP2-SA7R ROBO Cylinder Slider Type 73mm Width Pulse Motor Side-Mounted Motor

■ Configuration: **RCP2** — **SA7R** — **I** — **56P** — — — — —

Series — Type — Encoder — Motor — Lead — Stroke — Compatible Controllers — Cable Length — Option

I: Incremental * The Simple absolute encoder models are labeled as "I".
 56P: Pulse motor 56 □ size
 16: 16mm
 8: 8mm
 4: 4mm
 50: 50mm
 800: 800mm (50mm pitch increments)
 P1: PCON
 RPCON
 PSEL
 P3: PMEC
 PSEP
 N: None
 P: 1m
 S: 3m
 M: 5m
 X □ □ : Custom Length
 R □ □ : Robot cable
 See Options below * Be sure to specify which side the motor is to be mounted (ML/MR).

* See page Pre-35 for explanation of each code that makes up the configuration name.

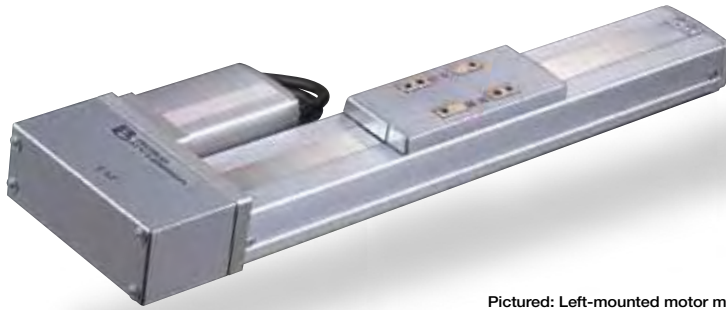

Pictured: Left-mounted motor model (ML).

Technical References A-5

- POINT** Notes on Selection
- When the stroke increases, the maximum speed will drop to prevent the ball screw from reaching the critical rotational speed. Use the actuator specification table below to check the maximum speed at the stroke you desire.
 - Since the RCP2 series use a pulse motor, the load capacity decreases at high speeds. Check in the Speed vs. Load Capacity graph to see if your desired speed and load capacity are supported.
 - The load capacity is based on operation at an acceleration of 0.3G (0.2G for the 4mm-lead model, or when used vertically). These values are the upper limits for the acceleration.

■ Speed vs. Load Capacity
 Due to the characteristics of the pulse motor, the RCP2 series' load capacity decreases at high speeds. In the table below, check if your desired speed and load capacity are supported.

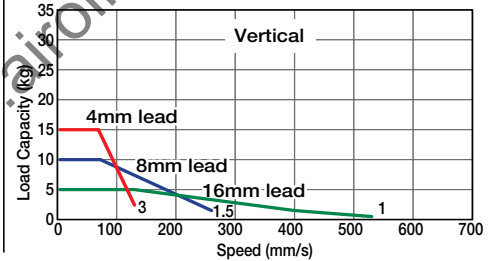
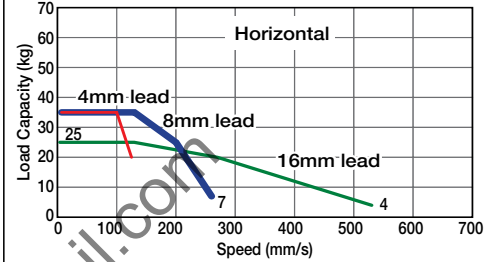

Actuator Specifications

■ Lead and Load Capacity (Note 1) Please note that the maximum load capacity decreases as the speed increases.

Model	Lead (mm)	Max. Load Capacity (Note 1)		Stroke (mm)
		Horizontal (kg)	Vertical (kg)	
RCP2-SA7R-I-56P-16-①-②-③-④	16	~ 25	~ 5	50 ~ 800 (50mm increments)
RCP2-SA7R-I-56P-8-①-②-③-④	8	~ 35	~ 10	
RCP2-SA7R-I-56P-4-①-②-③-④	4	~ 35	~ 15	

Legend ① Stroke ② Compatible controller ③ Cable length ④ Options

■ Stroke and Maximum Speed

Stroke Lead	50 ~ 700 (50mm increments)	~ 800 (mm)
	16	533 <400>
8	266	240
4	133	120

* The values enclosed in < > apply to vertical setting. (Unit: mm/s)

① Stroke List

Stroke (mm)	Standard Price
50/100	-
150/200	-
250/300	-
350/400	-
450/500	-
550/600	-
650/700	-
750/800	-

③ Cable List

Type	Cable Symbol	Standard Price
Standard	P (1m)	-
	S (3m)	-
	M (5m)	-
Special Lengths	X06 (6m) ~ X10 (10m)	-
	X11 (11m) ~ X15 (15m)	-
	X16 (16m) ~ X20 (20m)	-
	R01 (1m) ~ R03 (3m)	-
Robot Cable	R04 (4m) ~ R05 (5m)	-
	R06 (6m) ~ R10 (10m)	-
	R11 (11m) ~ R15 (15m)	-
	R16 (16m) ~ R20 (20m)	-

* See page A-39 for cables for maintenance.

④ Option List

Name	Option Code	See Page	Standard Price
Brake	B	→ A-25	-
Reversed-home	NM	→ A-33	-
Left-Mounted Motor (Standard)	ML	→ A-33	-
Right-Mounted Motor	MR	→ A-33	-
Slider Roller	SR	→ A-36	-

Actuator Specifications

Item	Description
Drive System	Ball screw ø12mm C10 grade
Positioning Repeatability	±0.02mm
Lost Motion	0.1mm or less
Base	Material: Aluminum (white alumite treated)
Allowable Static Moment	Ma: 50.4 N·m Mb: 71.9 N·m Mc: 138.0 N·m
Allowable Dynamic Moment (*)	Ma: 13.9 N·m Mb: 19.9 N·m Mc: 38.3 N·m
Overhang Load Length	Ma direction: 230mm or less; Mb-Mc direction: 230mm or less
Ambient Operating Temp./Humidity	0~40°C, 85% RH or less (Non-condensing)

(*) Based on 5,000km travel life.

Directions of Allowable Load Moments

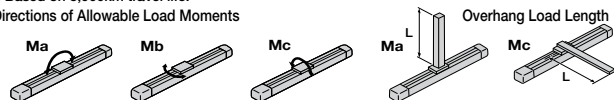

Dimensions

CAD drawings can be downloaded from IAI website. www.intelligentactuator.com

For Special Orders A-9



*For the reversed-home model, the dimensions (distance to home) on the motor-side and that on the opposite side are flipped.

- *1. The motor-encoder cable is connected here. See page A-39 for details on cables.
 - *2. When homing, the slider moves to the ME; therefore, please watch for any interference with the surrounding objects.
 - ME: Mechanical end
 - SE: Stroke end
 - The values enclosed in "()" are reference dimensions.
- *The offset reference position for the moment Ma is the same as the SA7 type. (See P32)

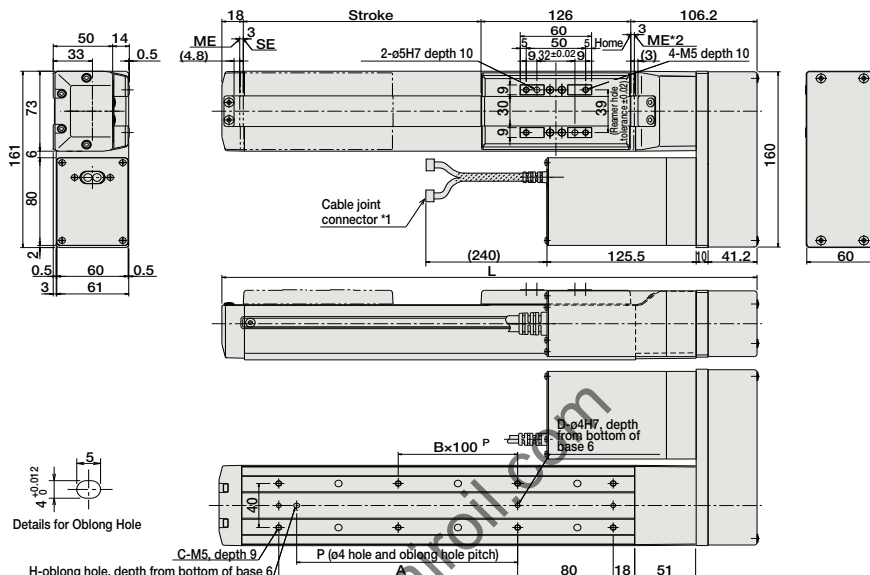

Dimensions of the brake section

* Adding a brake will increase the actuator's overall length by 43mm, and its weight by 0.6kg.

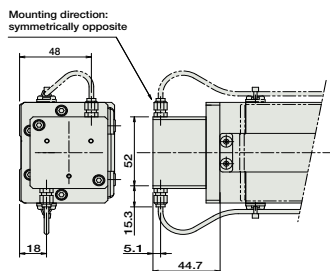

* For brake cable exiting from the side, it can only exit from the motor side.

■ Dimensions/Weight by Stroke

Stroke	50	100	150	200	250	300	350	400	450	500	550	600	650	700	750	800
L	300.2	350.2	400.2	450.2	500.2	550.2	600.2	650.2	700.2	750.2	800.2	850.2	900.2	950.2	1000.2	1050.2
A	0	100	100	200	200	300	300	400	400	500	500	600	600	700	700	800
B	0	0	0	1	1	2	2	3	3	4	4	5	5	6	6	7
C	4	5	6	8	8	10	10	12	12	14	14	16	16	18	18	20
D	2	3	3	3	3	3	3	3	3	3	3	3	3	3	3	3
H	0	1	1	1	1	1	1	1	1	1	1	1	1	1	1	1
P	0	85	85	185	185	285	285	385	385	485	485	585	585	685	685	785
Weight (kg)	4.5	4.7	5.0	5.2	5.4	5.6	5.9	6.1	6.3	6.5	6.8	7.0	7.2	7.4	7.7	7.9

② Compatible Controllers

The RCP2 series actuators can operate with the controllers below. Select the controller according to your usage.

Name	External View	Model	Description	Max. Positioning Points	Input Voltage	Power Supply Capacity	Standard Price	See Page
Solenoid Valve Type		PMEC-C-56PI-NP-2-①	Easy-to-use controller, even for beginners	3 points	AC100V AC200V	See P481	-	→ P477
		PSEP-C-56PI-NP-2-0	Operable with same signal as solenoid valve. Supports both single and double solenoid types. No homing necessary with simple absolute type.					
Splash-Proof Solenoid Valve Type		PSEP-CW-56PI-NP-2-0						
Positioner Type		PCON-C-56PI-NP-2-0	Positioning is possible for up to 512 points	512 points			-	
Safety-Compliant Positioner Type		PCON-CG-56PI-NP-2-0						
Pulse Train Input Type (Differential Line Driver)		PCON-PL-56PI-NP-2-0	Pulse train input type with differential line driver support	(-)	DC24V	2A max.	-	→ P525
Pulse Train Input Type (Open Collector)		PCON-PO-56PI-NP-2-0	Pulse train input type with open collector support					
Serial Communication Type		PCON-SE-56PI-N-0-0	Dedicated to serial communication	64 points				
Field Network Type		RPCON-56P	Dedicated to field network	768 points				→ P503
Program Control Type		PSEL-C-1-56PI-NP-2-0	Programmed operation is possible Can operate up to 2 axes	1500 points				→ P557

* This is for the single-axis PSEL.

* ① is a placeholder for the power supply voltage (1: 100V / 2: 100~240V).

RCP2-SS7R

ROBO Cylinder Slider Type 60mm Width Pulse Motor Side-Mounted Motor Steel Base

■ Configuration: **RCP2** — **SS7R** — **I** — **42P** — — — — —

Series — Type — Encoder — Motor — Lead — Stroke — Compatible Controllers — Cable Length — Option

I: Incremental
* The Simple absolute encoder models are labeled as "I".

42P: Pulse motor 42 □ size

12: 12mm
6: 6mm
3: 3mm

50: 50mm
600: 600mm (50mm pitch increments)

P1: PCON
RPCON
PSEL
P3: PMEC
PSEP

N: None
P: 1m
S: 3m
M: 5m
X □ □: Custom Length
R □ □: Robot cable

See Options below
* Be sure to specify which side the motor is to be mounted (ML/MR).

* See page Pre-35 for explanation of each code that makes up the configuration name.

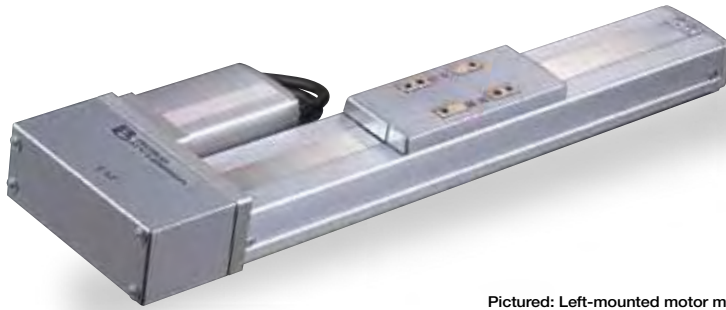

Pictured: Left-mounted motor model (ML).

Technical References A-5



- When the stroke increases, the maximum speed will drop to prevent the ball screw from reaching the critical rotational speed. Use the actuator specification table below to check the maximum speed at the stroke you desire.
- Since the RCP2 series use a pulse motor, the load capacity decreases at high speeds. Check in the Speed vs. Load Capacity graph to see if your desired speed and load capacity are supported.
- The load capacity is based on operation at an acceleration of 0.3G (0.2G for the 3mm-lead model, or when used vertically). These values are the upper limits for the acceleration.

Speed vs. Load Capacity

Due to the characteristics of the pulse motor, the RCP2 series' load capacity decreases at high speeds. In the table below, check if your desired speed and load capacity are supported.

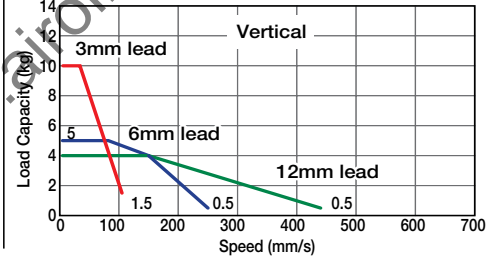
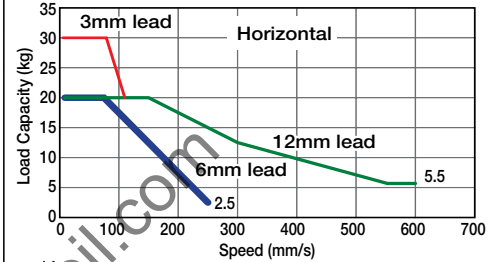

Actuator Specifications

Lead and Load Capacity

(Note 1) Please note that the maximum load capacity decreases as the speed increases.

Stroke and Maximum Speed

Model	Lead (mm)	Max. Load Capacity (Note 1)		Stroke (mm)
		Horizontal (kg)	Vertical (kg)	
RCP2-SS7R-I-42P-12-①-②-③-④	12	~ 20	~ 4	50 ~ 600 (50mm increments)
RCP2-SS7R-I-42P-6-①-②-③-④	6	~ 20	~ 5	
RCP2-SS7R-I-42P-3-①-②-③-④	3	~ 30	~ 10	

Stroke / Lead	50 ~ 500 (50mm increments)	~ 600 (mm)
	12	600 <440>
6	250	230
3	105	105

Legend ① Stroke ② Compatible controller ③ Cable length ④ Options

* The values enclosed in < > apply to vertical setting. (Unit: mm/s)

① Stroke List

Stroke (mm)	Standard Price
50/100	—
150/200	—
250/300	—
350/400	—
450/500	—
550/600	—

③ Cable List

Type	Cable Symbol	Standard Price
Standard	P (1m)	—
	S (3m)	—
	M (5m)	—
Special Lengths	X06 (6m) ~ X10 (10m)	—
	X11 (11m) ~ X15 (15m)	—
	X16 (16m) ~ X20 (20m)	—
Robot Cable	R01 (1m) ~ R03 (3m)	—
	R04 (4m) ~ R05 (5m)	—
	R06 (6m) ~ R10 (10m)	—
	R11 (11m) ~ R15 (15m)	—
	R16 (16m) ~ R20 (20m)	—

* See page A-39 for cables for maintenance.

④ Option List

Name	Option Code	See Page	Standard Price
Brake	B	→ A-25	—
Reversed-home	NM	→ A-33	—
Left-Mounted Motor (Standard)	ML	→ A-33	—
Right-Mounted Motor	MR	→ A-33	—
Slider Roller	SR	→ A-36	—

Actuator Specifications

Item	Description
Drive System	Ball screw Ø10mm C10 grade
Positioning Repeatability	±0.02mm
Lost Motion	0.1mm or less
Base	Material: Special alloy steel
Allowable Static Moment	Ma: 79.4 N·m Mb: 79.4 N·m Mc: 172.9 N·m
Allowable Dynamic Moment (*)	Ma: 14.7 N·m Mb: 14.7 N·m Mc: 33.3 N·m
Overhang Load Length	Ma direction: 300mm or less; Mb-Mc direction: 300mm or less
Ambient Operating Temp./Humidity	0~40°C, 85% RH or less (Non-condensing)

(*) Based on 10,000km travel life.

Directions of Allowable Load Moments

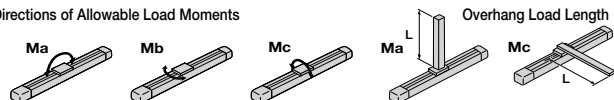

Dimensions

CAD drawings can be downloaded from IAI website. www.intelligentactuator.com

For Special Orders A-9



*For the reversed-home model, the dimensions (distance to home) on the motor-side and that on the opposite side are flipped.

- * The reference surface is the same as the SS7C type. (See P34)
- * The offset reference position for the moment Ma is the same as the SS7C type. (See P34)

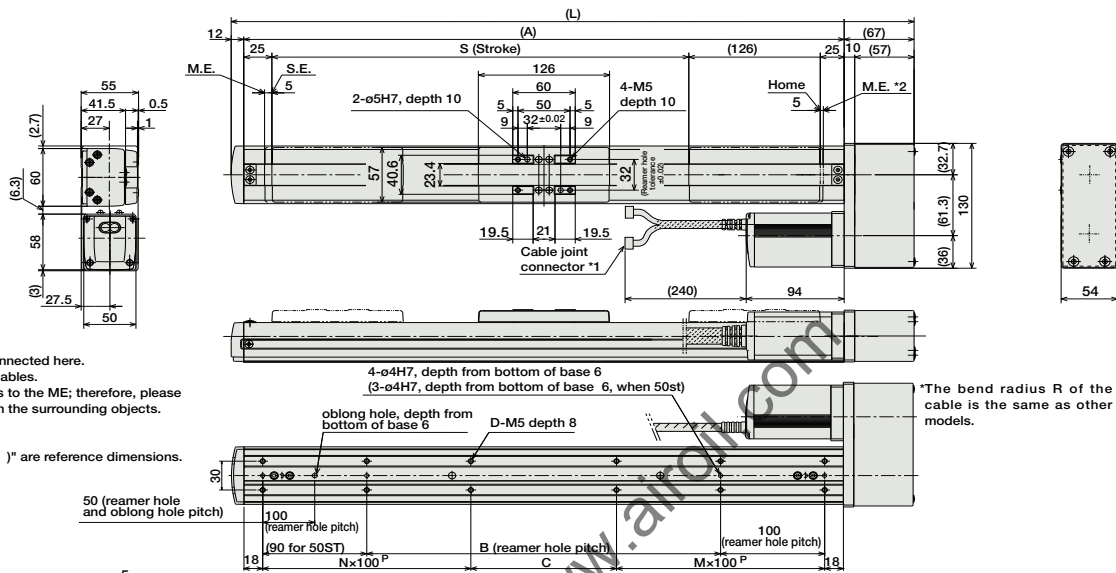

- *1: The motor-encoder cable is connected here. See page A-39 for details on cables.
- *2: When homing, the slider moves to the ME; therefore, please watch for any interference with the surrounding objects.
ME: Mechanical end
SE: Stroke end
The dimensions enclosed in "()" are reference dimensions.

*The bend radius R of the cable is the same as other models.

Dimensions of the brake section

* Adding a brake increases the actuator's overall length by 24.5mm and its weight by 0.3kg.

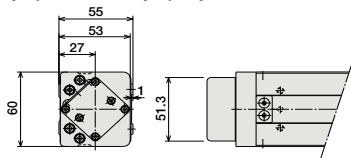

Dimensions/Weight by Stroke

Stroke	50	100	150	200	250	300	350	400	450	500	550	600
L	305	355	405	455	505	555	605	655	705	755	805	855
A	226	276	326	376	426	476	526	576	626	676	726	776
B	0	40	90	140	190	240	290	340	390	440	490	540
C	90	40	90	140	190	40	90	140	190	40	90	140
D	6	8	8	8	8	12	12	12	12	16	16	16
M	1	1	1	1	1	2	2	2	2	3	3	3
N	0	1	1	1	1	2	2	2	2	3	3	3
Weight (kg)	3.8	4.1	4.4	4.7	5.1	5.4	5.8	6.1	6.4	6.7	7.1	7.4

* The brake cable is passed through the actuator body and connected to the motor cable.

Compatible Controllers

The RCP2 series actuators can operate with the controllers below. Select the controller according to your usage.

Name	External View	Model	Description	Max. Positioning Points	Input Voltage	Power Supply Capacity	Standard Price	See Page
Solenoid Valve Type		PMEC-C-42PI-NP-2-①	Easy-to-use controller, even for beginners	3 points	AC100V AC200V	See P481	-	→ P477
		PSEP-C-42PI-NP-2-0	Operable with same signal as solenoid valve. Supports both single and double solenoid types. No homing necessary with simple absolute type.					
Splash-Proof Solenoid Valve Type		PSEP-CW-42PI-NP-2-0						
Positioner Type		PCON-C-42PI-NP-2-0	Positioning is possible for up to 512 points	512 points			-	
Safety-Compliant Positioner Type		PCON-CG-42PI-NP-2-0						
Pulse Train Input Type (Differential Line Driver)		PCON-PL-42PI-NP-2-0	Pulse train input type with differential line driver support	(-)	DC24V	2A max.	-	→ P525
Pulse Train Input Type (Open Collector)		PCON-PO-42PI-NP-2-0	Pulse train input type with open collector support					
Serial Communication Type		PCON-SE-42PI-N-0-0	Dedicated to serial communication	64 points				
Field Network Type		RPCON-42P	Dedicated to field network	768 points				→ P503
Program Control Type		PSEL-C-1-42PI-NP-2-0	Programmed operation is possible. Can operate up to 2 axes	1500 points				→ P557

* This is for the single-axis PSEL.

* ① is a placeholder for the power supply voltage (1: 100V / 2: 100~240V).

- Slider Type
- Mini
- Standard
- Controllers Integrated
- Rod Type
- Mini
- Standard
- Controllers Integrated
- Table/Arm/Flat Type
- Mini
- Standard
- Gripper/Rotary Type
- Linear Servo Type
- Cleanroom Type
- Splash Proof
- Controllers
- PMEC /AMEC
- PSEP /ASEP
- ROBO NET
- ERC2
- PCON
- ACON
- SCON
- PSEL
- ASEL
- SSEL
- XSEL
- Pulse Motor
- Servo Motor (24V)
- Servo Motor (200V)
- Linear Servo Motor

RCP2-SS8R

ROBO Cylinder Slider Type 80mm Width Pulse Motor Side-Mounted Motor Steel Base

■ Configuration: **RCP2** — **SS8R** — **I** — **56P** — — — — —

Series — Type — Encoder — Motor — Lead — Stroke — Compatible Controllers — Cable Length — Option

I: Incremental
* The Simple absolute encoder models are labeled as "I".

56P: Pulse motor
56 □ size

20: 20mm
10: 10mm
5: 5mm

50: 50mm
1000: 1000mm (50mm pitch increments)

P1: PCON
RPCON
PSEL
P3: PMEC
PSEP

N: None
P: 1m
S: 3m
M: 5m
X □ □: Custom Length
R □ □: Robot cable

See Options below
* Be sure to specify which side the motor is to be mounted (ML/MR).

* See page Pre-35 for explanation of each code that makes up the configuration name.

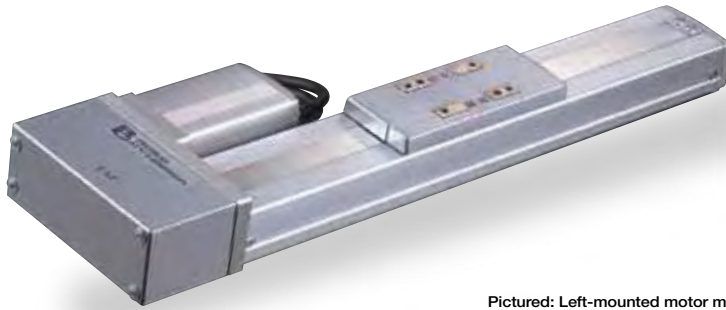

Pictured: Left-mounted motor model (ML).

Technical References A-5

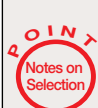

- When the stroke increases, the maximum speed will drop to prevent the ball screw from reaching the critical rotational speed. Use the actuator specification table below to check the maximum speed at the stroke you desire.
- Since the RCP2 series use a pulse motor, the load capacity decreases at high speeds. Check in the Speed vs. Load Capacity graph to see if your desired speed and load capacity are supported.
- The load capacity is based on operation at an acceleration of 0.3G (0.2G for the 5mm-lead model, or when used vertically). These values are the upper limits for the acceleration.

■ Speed vs. Load Capacity
Due to the characteristics of the pulse motor, the RCP2 series' load capacity decreases at high speeds. In the table below, check if your desired speed and load capacity are supported.

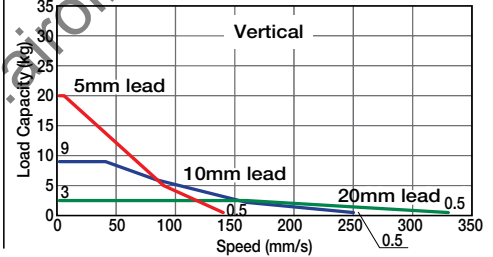
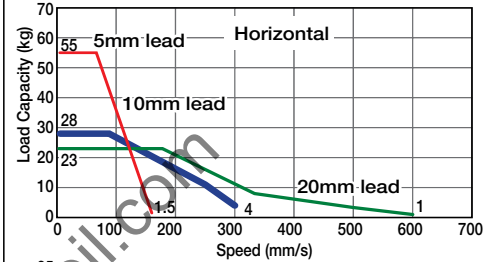

Actuator Specifications

Lead and Load Capacity

(Note 1) Please note that the maximum load capacity decreases as the speed increases.

Model	Lead (mm)	Max. Load Capacity (Note 1)		Stroke (mm)
		Horizontal (kg)	Vertical (kg)	
RCP2-SS8R-I-56P-20-①-②-③-④	20	~ 23	~ 3	50 ~ 1000 (50mm increments)
RCP2-SS8R-I-56P-10-①-②-③-④	10	~ 28	~ 9	
RCP2-SS8R-I-56P-5-①-②-③-④	5	~ 55	~ 20	

Legend ① Stroke ② Compatible controller ③ Cable length ④ Options

Stroke and Maximum Speed

Stroke Lead	50 ~ 800 (50mm increments)	~ 900 (mm)	~ 1000 (mm)
	20	600 <333>	600 <333>
10	300 <250>	300 <250>	255 <250>
5	160 <140>	155 <140>	125 <140>

* The values enclosed in < > apply to vertical setting. (Unit: mm/s)

① Stroke List

Stroke (mm)	Standard Price
50/100	—
150/200	—
250/300	—
350/400	—
450/500	—
550/600	—
650/700	—
750/800	—
850/900	—
950/1000	—

③ Cable List

Type	Cable Symbol	Standard Price
Standard	P (1m)	—
	S (3m)	—
	M (5m)	—
Special Lengths	X06 (6m) ~ X10 (10m)	—
	X11 (11m) ~ X15 (15m)	—
	X16 (16m) ~ X20 (20m)	—
Robot Cable	R01 (1m) ~ R03 (3m)	—
	R04 (4m) ~ R05 (5m)	—
	R06 (6m) ~ R10 (10m)	—
	R11 (11m) ~ R15 (15m)	—
	R16 (16m) ~ R20 (20m)	—

* See page A-39 for cables for maintenance.

④ Option List

Name	Option Code	See Page	Standard Price
Brake	B	→ A-25	—
Reversed-home	NM	→ A-35	—
Left-Mounted Motor (Standard)	ML	→ A-33	—
Right-Mounted Motor	MR	→ A-33	—
Slider Roller	SR	→ A-36	—

Actuator Specifications

Item	Description
Drive System	Ball screw ø16mm C10 grade
Positioning Repeatability	±0.02mm
Lost Motion	0.1mm or less
Base	Material: Special alloy steel
Allowable Static Moment	Ma: 198.9 N·m Mb: 198.9 N·m Mc: 416.7 N·m
Allowable Dynamic Moment (*)	Ma: 36.3 N·m Mb: 36.3 N·m Mc: 77.4 N·m
Overhang Load Length	Ma direction: 450mm or less; Mb-Mc direction: 450mm or less
Ambient Operating Temp./Humidity	0~40°C, 85% RH or less (Non-condensing)

(*) Based on 10,000km travel life.

Directions of Allowable Load Moments

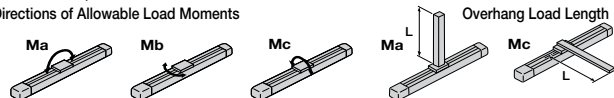

Dimensions

CAD drawings can be downloaded from IAI website. www.intelligentactuator.com

For Special Orders A-9



*For the reversed-home model, the dimensions (distance to home) on the motor-side and that on the opposite side are flipped.

- * The reference surface is the same as the SS8C type. (See P36)
- * The offset reference position for the moment Ma is the same as the SS8C type. (See P36)

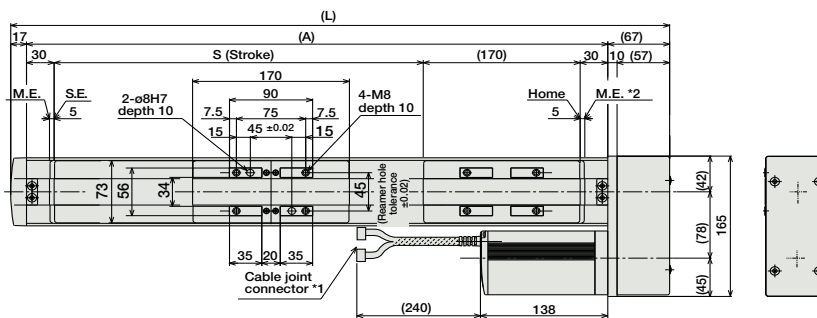
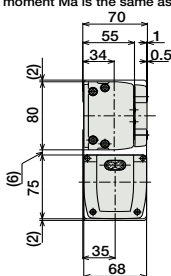

- *1: The motor-encoder cable is connected here. See page A-39 for details on cables.
- *2: When homing, the slider moves to the ME; therefore, please watch for any interference with the surrounding objects.
ME: Mechanical end
SE: Stroke end
The dimensions enclosed in "()" are reference dimensions.

Dimensions of the brake section

* Adding a brake will increase the actuator's length by 26mm and its weight by 0.5kg.

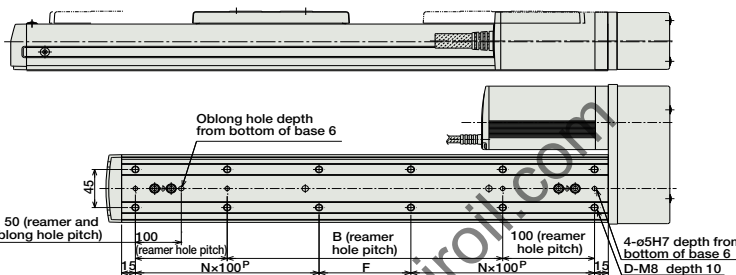
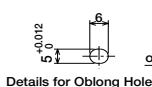
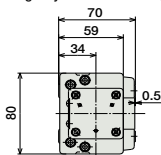

* The brake cable is passed through the actuator body and connected to the motor cable.

■ Dimensions/Weight by Stroke

Stroke	50	100	150	200	250	300	350	400	450	500	550	600	650	700	750	800	850	900	950	1000
L	364	414	464	514	564	614	664	714	764	814	864	914	964	1014	1064	1114	1164	1214	1264	1314
A	280	330	380	430	480	530	580	630	680	730	780	830	880	930	980	1030	1080	1130	1180	1230
B	50	100	150	200	250	300	350	400	450	500	550	600	650	700	750	800	850	900	950	1000
D	8	8	8	10	12	12	12	14	16	16	16	18	20	20	20	22	24	24	24	26
F	50	100	150	0	50	100	150	0	50	100	150	0	50	100	150	0	50	100	150	0
N	1	1	1	2	2	2	2	3	3	3	3	4	4	4	4	5	5	5	5	6
Weight (kg)	7.4	7.9	8.5	9.0	9.5	10	10.5	11.1	11.6	12.1	12.7	13.2	13.7	14.3	14.8	15.3	15.8	16.4	16.9	17.4

② Compatible Controllers

The RCP2 series actuators can operate with the controllers below. Select the controller according to your usage.

Name	External View	Model	Description	Max. Positioning Points	Input Voltage	Power Supply Capacity	Standard Price	See Page
Solenoid Valve Type		PMEC-C-56PI-NP-2-①	Easy-to-use controller, even for beginners	3 points	AC100V AC200V	See P481	-	→ P477
		PSEP-C-56PI-NP-2-0	Operable with same signal as solenoid valve. Supports both single and double solenoid types. No homing necessary with simple absolute type.					
Splash-Proof Solenoid Valve Type		PSEP-CW-56PI-NP-2-0						
Positioner Type		PCON-C-56PI-NP-2-0	Positioning is possible for up to 512 points	512 points	DC24V	2A max.	-	→ P525
Safety-Compliant Positioner Type		PCON-CG-56PI-NP-2-0						
Pulse Train Input Type (Differential Line Driver)		PCON-PL-56PI-NP-2-0	Pulse train input type with differential line driver support	(-)	DC24V	2A max.	-	→ P525
Pulse Train Input Type (Open Collector)		PCON-PO-56PI-NP-2-0	Pulse train input type with open collector support					
Serial Communication Type		PCON-SE-56PI-N-0-0	Dedicated to serial communication	64 points				
Field Network Type		RPCON-56P	Dedicated to field network	768 points				→ P503
Program Control Type		PSEL-C-1-56PI-NP-2-0	Programmed operation is possible. Can operate up to 2 axes	1500 points				→ P557

* This is for the single-axis PSEL.
* ① is a placeholder for the power supply voltage (1: 100V / 2: 100~240V).

RCP2-HS8R

ROBO Cylinder High-Speed Slider Type 80mm Width Pulse Motor
Side-Mounted Motor Steel Base

■ Configuration: **RCP2** — **HS8R** — **I** — **86P** — — — **P2** — —

Series — Type — Encoder — Motor — Lead — Stroke — Compatible Controllers — Cable Length — Option

I: Incremental
* The Simple absolute encoder models are labeled as "I".

86P: Pulse motor
56 □ high output

30:30mm

50: 50mm
1000:1000mm (50mm pitch increments)

P2:PCON-CF

N : None
P : 1m
S : 3m
M : 5m
X □ □ : Custom Length
R □ □ : Robot cable

BE : Brake (Cable exiting end)
BL : Brake (Cable exiting left)
BR : Brake (Cable exiting right)
NM : Reversed-home
SR : Slider Roller

* See page Pre-35 for explanation of each code that makes up the configuration name.

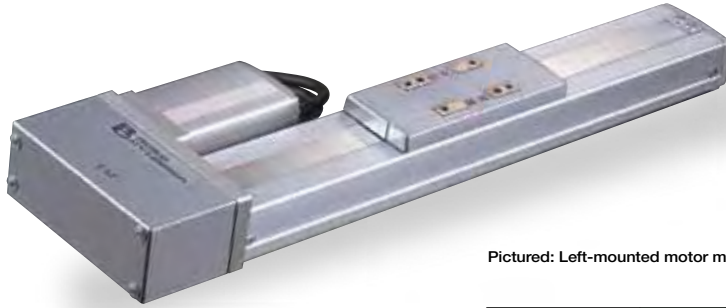

Pictured: Left-mounted motor model (ML).

Technical References A-5

- Notes on Selection**
- Due to the large lead of the ball screw in high-speed actuators, operating at low speeds may cause vibration and/or noise. Therefore, use the actuator at speeds over 100mm/s.
 - When the stroke increases, the maximum speed will drop to prevent the ball screw from reaching the critical rotational speed. Use the actuator specification table below to check the maximum speed at the stroke you desire.
 - Since the RCP2 series use a pulse motor, the load capacity decreases at high speeds. Check in the Speed vs. Load Capacity graph to see if your desired speed and load capacity are supported.
 - The load capacity is based on operation at an acceleration of 0.3G (0.2G when used vertically). The upper limit for the acceleration is 0.5G for horizontal use and 0.2G for vertical use.

■ Speed vs. Load Capacity
Due to the characteristics of the pulse motor, the RCP2 series' load capacity decreases at high speeds. In the table below, check if your desired speed and load capacity are supported.

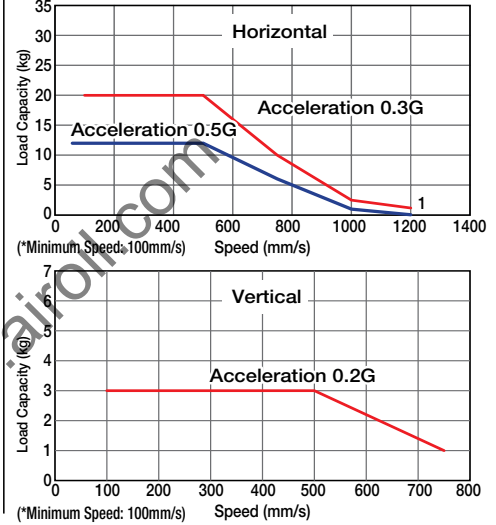

Actuator Specifications

■ Lead and Load Capacity (Note 1) Please note that the maximum load capacity decreases as the speed increases.

Model	Lead (mm)	Max. Load Capacity (Note 1)		Stroke (mm)
		Horizontal (kg)	Vertical (kg)	
RCP2-HS8R-I-86P-30-①-P2-②-③	30	~ 20	~ 3	50 ~ 1000 (50mm increments)

Legend ① Stroke ② Cable length ③ Options

■ Stroke and Maximum Speed

Stroke / Lead	50 ~ 800 (50mm increments)	~ 900 (mm)	~ 1000 (mm)
	30	1200 <750>	1000 <750>

* The values enclosed in < > apply to vertical setting. (Unit: mm/s)

① Stroke List

Stroke (mm)	Standard Price
50/100	-
150/200	-
250/300	-
350/400	-
450/500	-
550/600	-
650/700	-
750/800	-
850/900	-
950/1000	-

② Cable List

Type	Cable Symbol	Standard Price
Standard	P (1m)	-
	S (3m)	-
	M (5m)	-
Special Lengths	X06 (6m) ~ X10 (10m)	-
	X11 (11m) ~ X15 (15m)	-
	X16 (16m) ~ X20 (20m)	-
	R01 (1m) ~ R03 (3m)	-
Robot Cable	R04 (4m) ~ R05 (5m)	-
	R06 (6m) ~ R10 (10m)	-
	R11 (11m) ~ R15 (15m)	-
	R16 (16m) ~ R20 (20m)	-

* See page A-39 for cables for maintenance.

③ Option List

Name	Option Code	See Page	Standard Price
Brake	B	→ A-25	-
Reversed-home	NM	→ A-33	-
Left-Mounted Motor (Standard)	ML	→ A-33	-
Right-Mounted Motor	MR	→ A-33	-
Slider Roller	SR	→ A-36	-

Actuator Specifications

Item	Description
Drive System	Ball screw ø16mm C10 grade
Positioning Repeatability	±0.02mm
Lost Motion	0.1mm or less
Base	Material: Special alloy steel
Allowable Static Moment	Ma: 198.9 N·m Mb: 198.9 N·m Mc: 416.7 N·m
Allowable Dynamic Moment (*)	Ma: 36.3 N·m Mb: 36.3 N·m Mc: 77.4 N·m
Overhang Load Length	Ma direction: 450mm or less; Mb-Mc direction: 450mm or less
Ambient Operating Temp./Humidity	0~40°C, 85% RH or less (Non-condensing)

(*) Based on 10,000km travel life.

Directions of Allowable Load Moments

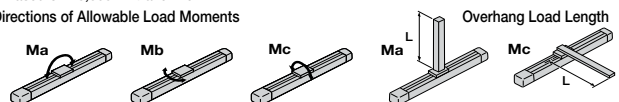

Dimensions

CAD drawings can be downloaded from IAI website. www.intelligentactuator.com

For Special Orders A-9



*For the reversed-home model, the dimensions (distance to home) on the motor-side and that on the opposite side are flipped.

- * The reference surface is the same as the HS8C type. (See P38)
- * The offset reference position for the moment Ma is the same as the HS8C type. (See P38)

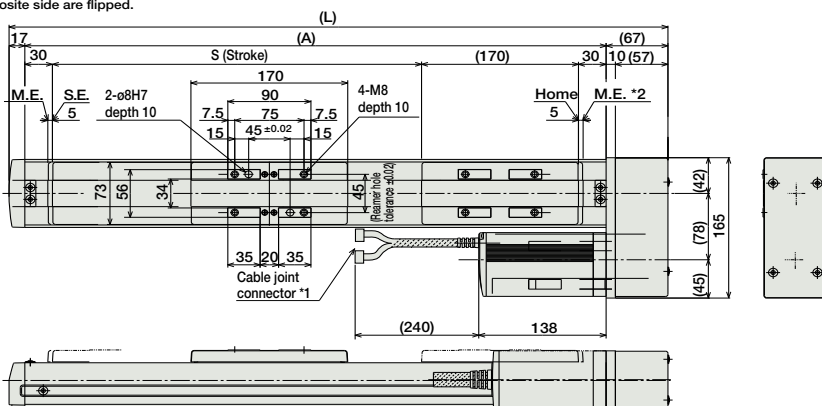
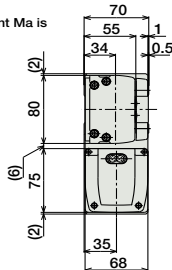

- *1: The motor-encoder cable is connected here. See page A-39 for details on cables.
- *2 When homing, the slider moves to the ME; therefore, please watch for any interference with the surrounding objects.
ME: Mechanical end
SE: Stroke end
The dimensions enclosed in () are reference dimensions.

Dimensions of the brake section

* Adding a brake will increase the actuator's length by 26mm and its weight by 0.5kg.

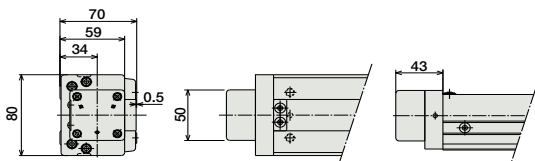

Details for Oblong Hole

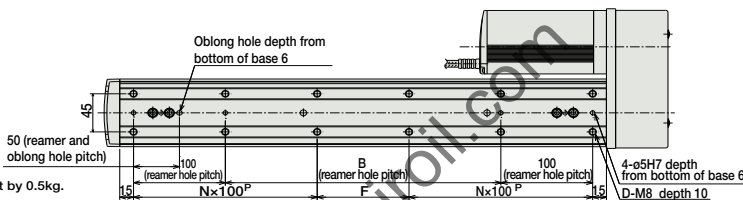

* The brake cable is passed through the actuator body and connected to the motor cable.

■ Dimensions/Weight by Stroke

Stroke	50	100	150	200	250	300	350	400	450	500	550	600	650	700	750	800	850	900	950	1000
L	364	414	464	514	564	614	664	714	764	814	864	914	964	1014	1064	1114	1164	1214	1264	1314
A	280	330	380	430	480	530	580	630	680	730	780	830	880	930	980	1030	1080	1130	1180	1230
B	50	100	150	200	250	300	350	400	450	500	550	600	650	700	750	800	850	900	950	1000
D	8	8	8	10	12	12	12	14	16	16	16	18	20	20	20	22	24	24	24	26
F	50	100	150	0	50	100	150	0	50	100	150	0	50	100	150	0	50	100	150	0
N	1	1	1	2	2	2	2	3	3	3	3	4	4	4	4	5	5	5	5	6
Weight (kg)	7.4	7.9	8.5	9.0	9.5	10	10.5	11.1	11.6	12.1	12.7	13.2	13.7	14.3	14.8	15.3	15.8	16.4	16.9	17.4

Compatible Controllers

The controller for the RCP2-HS8R type is a dedicated controller.

Name	External View	Model	Description	Max. Positioning Points	Input Voltage	Power Supply Capacity	Standard Price	See Page
Positioner Type		PCON-CF-86PI-NP-2-0	Positioning is possible for up to 512 points	512 points	DC24V	6A max.	-	→ P525

- Note:
- Please note that the encoder cable is a dedicated CF-type cable that is different from the PCON-C/CG/CY/PL/PO/SE controllers.
 - Note that a simple absolute unit cannot be used.

- Slider Type
- Mini
- Standard
- Controllers Integrated
- Rod Type
- Mini
- Standard
- Controllers Integrated
- Table/Arm/Flat Type
- Mini
- Standard
- Gripper/Rotary Type
- Linear Servo Type
- Cleanroom Type
- Splash Proof
- Controllers
- PMEC/AMEC
- PSEP/ASEP
- ROBO NET
- ERC2
- PCON
- ACON
- SCON
- PSEL
- ASEL
- SSEL
- XSEL
- Pulse Motor
- Servo Motor (24V)
- Servo Motor (200V)
- Linear Servo Motor

RCP2-BA6/BA6U

ROBO Cylinder Belt Type 53mm Width Pulse Motor
Top-Mounted Motor / Bottom-Mounted Motor

■ Configuration: **RCP2** — — **I** — **42P** — **54** — — — —

Series — Type — Encoder — Motor — Lead — Stroke — Compatible Controllers — Cable Length — Option

BA6 :Belt type Top-mounted motor
BA6U :Belt type Bottom-mounted motor

I: Incremental * The Simple absolute encoder models are labeled as "I".

42P: Pulse motor 42 □ size equivalent

54:54mm equivalent

500: 500mm
1000:1000mm (50mm pitch increments)

P1: PCON RPCON PSEL
P3: PMEC PSEP

N : None
P : 1m
S : 3m
M : 5m
X □ □ : Custom Length
R □ □ : Robot cable

NM : Reversed-home

* See page Pre-35 for explanation of each code that makes up the configuration name.



Technical References A-5

- POINT**
Notes on Selection
- Operating the belt type actuator at low speeds may cause vibration and/or resonance. Therefore, please set the speed at 100mm/s or faster.
 - Since the RCP2 series use a pulse motor, the load capacity decreases at high speeds. Check in the Speed vs. Load Capacity graph to see if your desired speed and load capacity are supported.
 - The load capacity is based on operation at an acceleration of 0.5G. 0.5G is the upper limit for the acceleration.

■ Speed vs. Load Capacity
Due to the characteristics of the pulse motor, the RCP2 series' load capacity decreases at high speeds. In the table below, check if your desired speed and load capacity are supported.

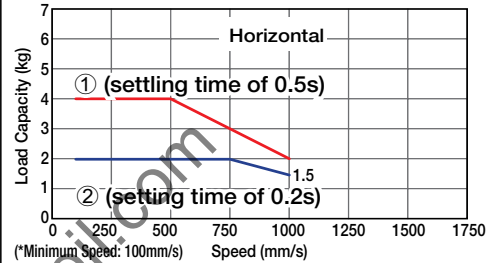

Note:
Graph ① is for standard specifications, with settling time of 0.5s for calculating the positioning time.
Graph ② reflects some changes in the controller settings. The load capacity is lower, however the settling time is decreased to 0.2s.
If the load capacity is lower than graph ②, and you want to shorten the positioning time, change the controller settings. (See the manual for details.)
(Vertical operation is not possible.)

Actuator Specifications				
Lead and Load Capacity			Stroke and Maximum Speed	
(Note 1) Please note that the maximum load capacity decreases as the speed increases.				
Model	Motor Mounting Direction	Lead (mm)	Max. Load Capacity (Note 1)	Stroke (mm)
RCP2-BA6-I-42P-54-①-②-③-④	Top	54 equivalent	Horizontal (kg) ~ 4 Vertical (kg) Not Allowed	500 ~ 1000 (50mm increments)
RCP2-BA6U-I-42P-54-①-②-③-④	Bottom	54 equivalent	Horizontal (kg) ~ 4 Vertical (kg) Not Allowed	500 ~ 1000 (50mm increments)

Legend ① Stroke ② Compatible controller ③ Cable length ④ Options (Unit: mm/s)

① Stroke List

Stroke (mm)	Standard Price
500	-
550	-
600	-
650	-
700	-
750	-
800	-
850	-
900	-
950	-
1000	-

③ Cable List

Type	Cable Symbol	Standard Price
Standard	P (1m)	-
	S (3m)	-
	M (5m)	-
Special Lengths	X06 (6m) ~ X10 (10m)	-
	X11 (11m) ~ X15 (15m)	-
	X16 (16m) ~ X20 (20m)	-
	R01 (1m) ~ R03 (3m)	-
Robot Cable	R04 (4m) ~ R05 (5m)	-
	R06 (6m) ~ R10 (10m)	-
	R11 (11m) ~ R15 (15m)	-
	R16 (16m) ~ R20 (20m)	-

* See page A-39 for cables for maintenance.

④ Option List

Name	Option Code	See Page	Standard Price
Reversed-home	NM	→ A-33	-

Actuator Specifications

Item	Description
Drive System	Timing Belt
Positioning Repeatability	±0.1mm
Lost Motion	0.1mm or less
Allowable Dynamic Moment (*)	Ma: 8.9 N·m Mb: 12.7 N·m Mc: 18.6 N·m
Overhang Load Length	Ma direction: 150mm or less; Mb-Mc direction: 150mm or less
Ambient Operating Temp./Humidity	0~40°C, 85% RH or less (Non-condensing)

(*) Based on 5,000km travel life.

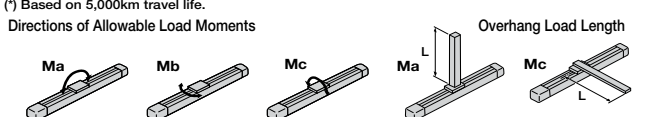

Dimensions

CAD drawings can be downloaded from IAI website. www.intelligentactuator.com

For Special Orders A-9



- *1 The motor-encoder cable is connected here. See page A-39 for details on cables.
- *2 When homing, the slider moves to the ME; therefore, please watch for any interference with the surrounding objects.
ME: Mechanical end
SE: Stroke end

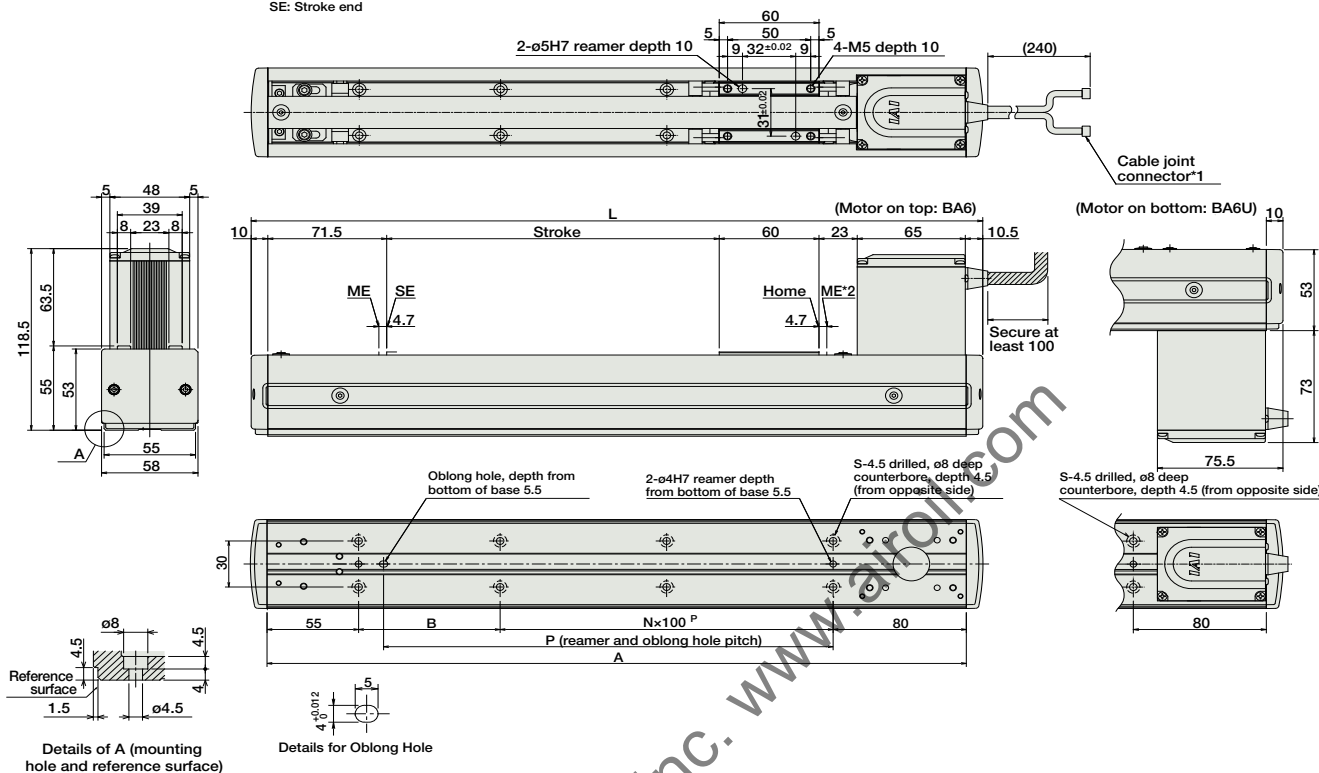

■ Dimensions/Weight by Stroke

Stroke	500	550	600	650	700	750	800	850	900	950	1000
L	740	790	840	890	940	990	1040	1090	1140	1190	1240
A	720	770	820	870	920	970	1020	1070	1120	1170	1220
B	85	35	85	35	85	35	85	35	85	35	85
N	5	6	6	7	7	8	8	9	9	10	10
P	570	620	670	720	770	820	870	920	970	1020	1070
S	14	16	16	18	18	20	20	22	22	24	24
Weight (kg)	2.8	2.9	3.0	3.2	3.3	3.4	3.5	3.7	3.8	3.9	4.1

② Compatible Controllers

The RCP2 series actuators can operate with the controllers below. Select the controller according to your usage.

Name	External View	Model	Description	Max. Positioning Points	Input Voltage	Power Supply Capacity	Standard Price	See Page
Solenoid Valve Type		PMEC-C-42PI-NP-2-①	Easy-to-use controller, even for beginners	3 points	AC100V AC200V	See P481	-	→ P477
		PSEP-C-42PI-NP-2-0	Operable with same signal as solenoid valve. Supports both single and double solenoid types. No homing necessary with simple absolute type.					
Splash-Proof Solenoid Valve Type		PSEP-CW-42PI-NP-2-0						
Positioner Type		PCON-C-42PI-NP-2-0	Positioning is possible for up to 512 points	512 points			-	
Safety-Compliant Positioner Type		PCON-CG-42PI-NP-2-0						
Pulse Train Input Type (Differential Line Driver)		PCON-PL-42PI-NP-2-0	Pulse train input type with differential line driver support	(-)	DC24V	2A max.	-	→ P525
Pulse Train Input Type (Open Collector)		PCON-PO-42PI-NP-2-0	Pulse train input type with open collector support					
Serial Communication Type		PCON-SE-42PI-N-0-0	Dedicated to serial communication	64 points				
Field Network Type		RPCON-42P	Dedicated to field network	768 points				→ P503
Program Control Type		PSEL-C-1-42PI-NP-2-0	Programmed operation is possible. Can operate up to 2 axes	1500 points				→ P557

* This is for the single-axis PSEL.
* ① is a placeholder for the power supply voltage (1: 100V / 2: 100~240V).

RCP2-BA7/BA7U

ROBO Cylinder Belt Type 68mm Width Pulse Motor
Top-Mounted Motor / Bottom-Mounted Motor

■ Configuration: **RCP2** — — **I** — **42P** — **54** — — — —

Series — Type — Encoder — Motor — Lead — Stroke — Compatible Controllers — Cable Length — Option

BA7 : Belt type Top-mounted motor
BA7U: Belt type Bottom-mounted motor

I: Incremental * The Simple absolute encoder models are labeled as "I".

42P: Pulse motor 42 □ size

54:54mm
600: 600mm
1200:1200mm (50mm pitch increments)

P1: PCON RPCON PSEL
P3: PMEC PSEP

N : None
P : 1m
S : 3m
M : 5m
X □ □ : Custom Length
R □ □ : Robot cable

NM: Reversed-home

* See page Pre-35 for explanation of each code that makes up the configuration name.



Technical References A-5

- POINT**
Notes on Selection
- Operating the belt type actuator at low speeds may cause vibration and/or resonance. Therefore, please set the speed at 100mm/s or faster.
 - Since the RCP2 series use a pulse motor, the load capacity decreases at high speeds. Check in the Speed vs. Load Capacity graph to see if your desired speed and load capacity are supported.
 - The load capacity is based on operation at an acceleration of 0.5G. 0.5G is the upper limit for the acceleration.

■ Speed vs. Load Capacity
Due to the characteristics of the pulse motor, the RCP2 series' load capacity decreases at high speeds. In the table below, check if your desired speed and load capacity are supported.

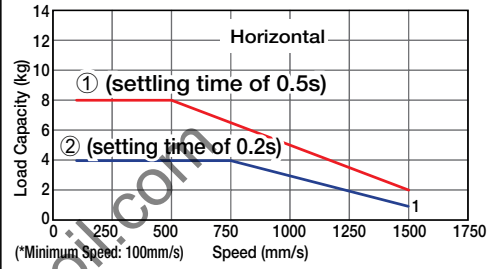

Note:
Graph ① is for standard specifications, with settling time of 0.5s for calculating the positioning time.
Graph ② reflects some changes in the controller settings. The load capacity is lower, however the settling time is decreased to 0.2s.
If the load capacity is lower than graph ②, and you want to shorten the positioning time, change the controller settings. (See the manual for details.)
(Vertical operation is not possible.)

Actuator Specifications				
Lead and Load Capacity			Stroke and Maximum Speed	
(Note 1) Please note that the maximum load capacity decreases as the speed increases.				
Model	Motor Mounting Direction	Lead (mm)	Max. Load Capacity (Note 1)	Stroke (mm)
RCP2-BA7-I-42P-54-①-②-③-④	Top	54 equivalent	Horizontal (kg) ~ 8 Vertical (kg) Not Allowed	600 ~ 1200 (50mm increments)
RCP2-BA7U-I-42P-54-①-②-③-④	Bottom	54 equivalent	Horizontal (kg) ~ 8 Vertical (kg) Not Allowed	600 ~ 1200 (50mm increments)

Legend ① Stroke ② Compatible controller ③ Cable length ④ Options (Unit: mm/s)

① Stroke List

Stroke (mm)	Standard Price
600	-
650	-
700	-
750	-
800	-
850	-
900	-
950	-
1000	-
1050	-
1100	-
1150	-
1200	-

③ Cable List

Type	Cable Symbol	Standard Price
Standard	P (1m)	-
	S (3m)	-
	M (5m)	-
Special Lengths	X06 (6m) ~ X10 (10m)	-
	X11 (11m) ~ X15 (15m)	-
	X16 (16m) ~ X20 (20m)	-
	R01 (1m) ~ R03 (3m)	-
Robot Cable	R04 (4m) ~ R05 (5m)	-
	R06 (6m) ~ R10 (10m)	-
	R11 (11m) ~ R15 (15m)	-
	R16 (16m) ~ R20 (20m)	-

* See page A-39 for cables for maintenance.

④ Option List

Name	Option Code	See Page	Standard Price
Reversed-home	NM	→ A-33	-

Actuator Specifications

Item	Description
Drive System	Timing Belt
Positioning Repeatability	±0.1mm
Lost Motion	0.1mm or less
Allowable Dynamic Moment (*)	Ma: 13.8 N·m Mb: 19.7 N·m Mc: 29.0 N·m
Overhang Load Length	Ma direction: 150mm or less; Mb-Mc direction: 150mm or less
Ambient Operating Temp./Humidity	0~40°C, 85% RH or less (Non-condensing)

(*) Based on 5,000km travel life.

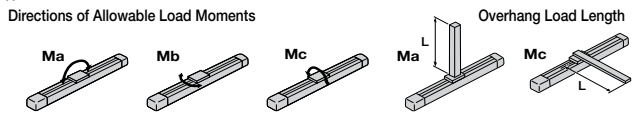

Dimensions

CAD drawings can be downloaded from IAI website. www.intelligentactuator.com

For Special Orders A-9



- *1 The motor-encoder cable is connected here. See page A-39 for details on cables.
- *2 When homing, the slider moves to the ME; therefore, please watch for any interference with the surrounding objects.
ME: Mechanical end
SE: Stroke end

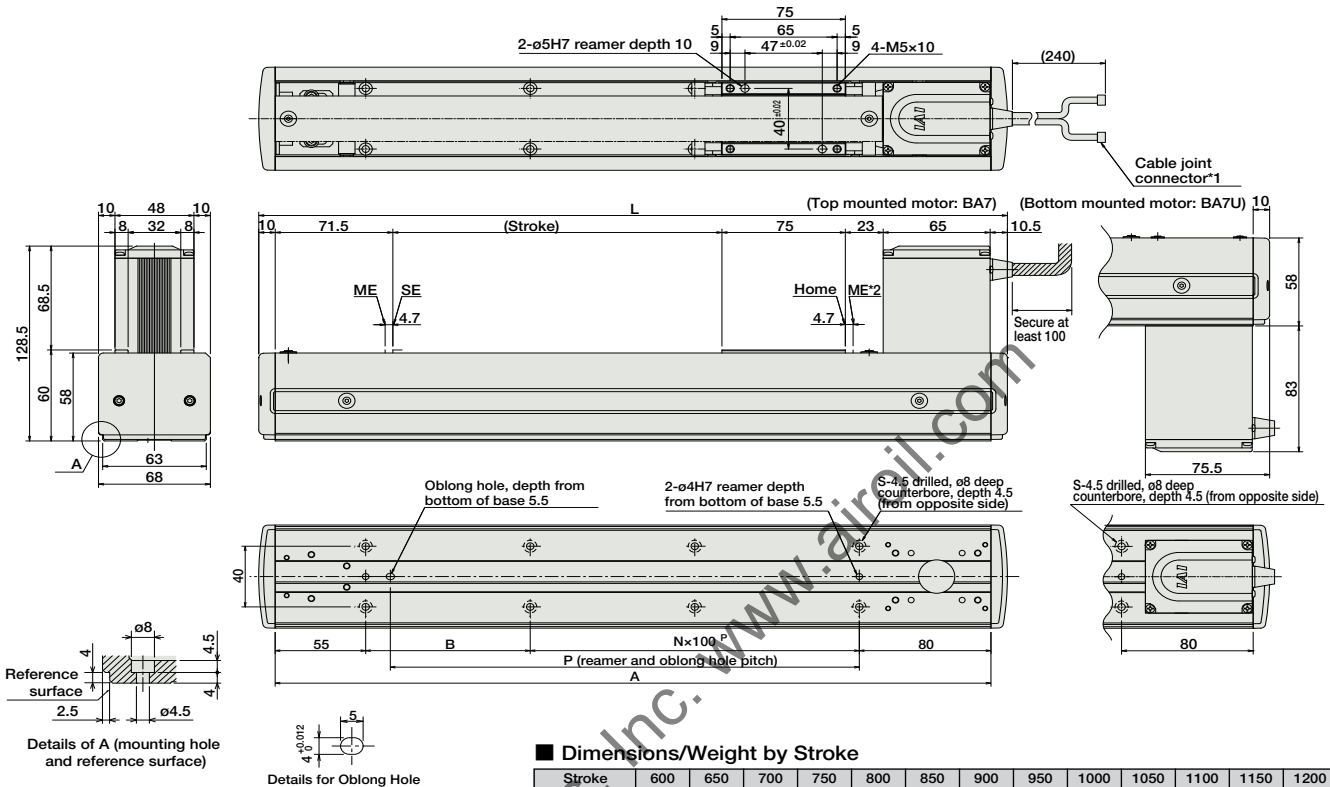

Dimensions/Weight by Stroke

Stroke	600	650	700	750	800	850	900	950	1000	1050	1100	1150	1200
L	855	905	955	1005	1055	1105	1155	1205	1255	1305	1355	1405	1455
A	835	885	935	985	1035	1085	1135	1185	1235	1285	1335	1385	1435
B	100	50	100	50	100	50	100	50	100	50	100	50	100
N	6	7	7	8	8	9	9	10	10	11	11	12	12
P	685	735	785	835	885	935	985	1035	1085	1135	1185	1235	1285
S	16	18	18	20	20	22	22	24	24	26	26	28	28
Weight (kg)	3.6	3.7	3.9	4.0	4.2	4.3	4.4	4.6	4.7	4.9	5.0	5.2	5.3

Compatible Controllers

The RCP2 series actuators can operate with the controllers below. Select the controller according to your usage.

Name	External View	Model	Description	Max. Positioning Points	Input Voltage	Power Supply Capacity	Standard Price	See Page
Solenoid Valve Type		PMEC-C-42PI-NP-2-①	Easy-to-use controller, even for beginners	3 points	AC100V AC200V	See P481	-	→ P477
		PSEP-C-42PI-NP-2-0	Operable with same signal as solenoid valve. Supports both single and double solenoid types. No homing necessary with simple absolute type.					
Splash-Proof Solenoid Valve Type		PSEP-CW-42PI-NP-2-0						→ P487
Positioner Type		PCON-C-42PI-NP-2-0	Positioning is possible for up to 512 points	512 points	DC24V	2A max.	-	→ P525
Safety-Compliant Positioner Type		PCON-CG-42PI-NP-2-0						
Pulse Train Input Type (Differential Line Driver)		PCON-PL-42PI-NP-2-0	Pulse train input type with differential line driver support	(-)	DC24V	2A max.	-	→ P525
Pulse Train Input Type (Open Collector)		PCON-PO-42PI-NP-2-0	Pulse train input type with open collector support					
Serial Communication Type		PCON-SE-42PI-N-0-0	Dedicated to serial communication	64 points				
Field Network Type		RPCON-42P	Dedicated to field network	768 points				→ P503
Program Control Type		PSEL-C-1-42PI-NP-2-0	Programmed operation is possible. Can operate up to 2 axes	1500 points				→ P557

* This is for the single-axis PSEL.
* ① is a placeholder for the power supply voltage (1: 100V / 2: 100~240V).

ERC2-SA6C

Controller-Integrated Slider Type 58mm Width Pulse Motor Straight Type

■ Configuration: **ERC2** — **SA6C** — **I** — **PM** — — — — —

Series — Type — Encoder — Motor — Lead — Stroke — I/O Type — Cable Length — Option

I: Incremental PM: Pulse motor 12:12mm 50:50mm NP: PIO N: None P: 1m B: Brake
 6: 6mm PSEL (NPN) Type S: 3m M: 5m NM: Reversed-home
 3: 3mm 600:600mm PN: PIO X : Custom Length W : Cable with connectors on both ends
 (50mm pitch increments) SE: SIO Type R : Robot cable RW : Robot cable with connectors on both ends

* See page Pre-35 for explanation of each code that makes up the configuration name.

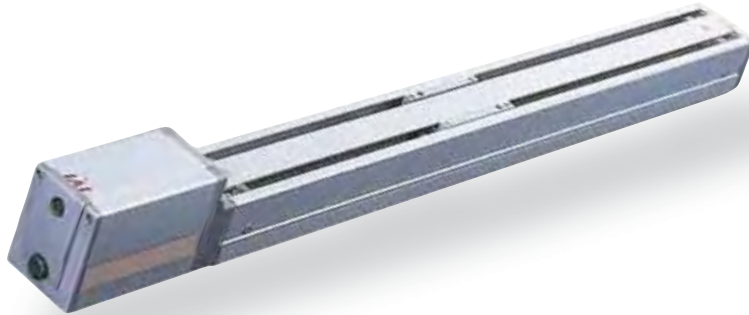

Technical References P. A-5



- When the stroke increases, the maximum speed will drop to prevent the ball screw from reaching the critical rotational speed. Use the actuator specification table below to check the maximum speed at the stroke you desire.
- Since the ERC2 series use a pulse motor, the load capacity decreases at high speeds. Check in the Speed vs. Load Capacity graph to see if your desired speed and load capacity are supported.
- The load capacity is based on operation at an acceleration of 0.3G (0.2G for the 3mm-lead model, or when using vertically). These values are the upper limits for the acceleration.

Speed vs. Load Capacity

Due to the characteristics of the pulse motor, the ERC2 series' load capacity decreases at high speeds. In the table below, check if your desired speed and load capacity are supported.

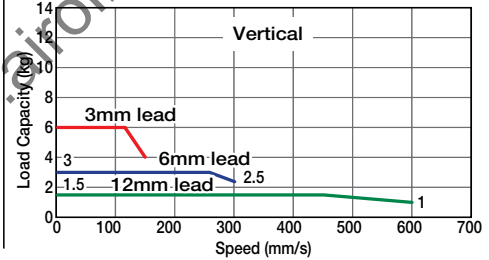
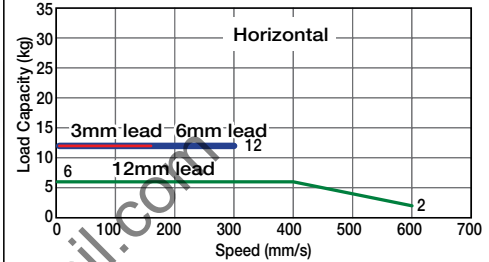

Actuator Specifications

Lead and Load Capacity

(Note 1) Please note that the maximum load capacity decreases as the speed increases.

Stroke and Maximum Speed

Model	Lead (mm)	Max. Load Capacity (Note 1)		Stroke (mm)
		Horizontal (kg)	Vertical (kg)	
ERC2-SA6C-I-PM-12- <input type="checkbox"/> - <input type="checkbox"/> - <input type="checkbox"/> - <input type="checkbox"/>	12	~ 6	~ 1.5	50 ~ 600 (50mm increments)
ERC2-SA6C-I-PM-6- <input type="checkbox"/> - <input type="checkbox"/> - <input type="checkbox"/> - <input type="checkbox"/>	6	12	~ 3	
ERC2-SA6C-I-PM-3- <input type="checkbox"/> - <input type="checkbox"/> - <input type="checkbox"/> - <input type="checkbox"/>	3	12	~ 6	

Stroke / Lead	50 ~ 550 (50mm increments)	600 (mm)
	12	600
6	300	255
3	150	125

Legend Stroke I/O type Cable length Options

(Unit: mm/s)

① Stroke List

Stroke (mm)	Standard Price
50	-
100	-
150	-
200	-
250	-
300	-
350	-
400	-
450	-
500	-
550	-
600	-

③ Cable List

Type	Cable Symbol	Standard Price
Standard	P (1m)	-
	S (3m)	-
	M (5m)	-
Special Lengths	X06 (6m) ~ X10 (10m)	-
Connectors on Both Ends	W01 (1m) ~ W03 (3m)	-
	W04 (4m) ~ W05 (5m)	-
	W06 (6m) ~ W10 (10m)	-
Robot Cable	R01 (1m) ~ R03 (3m)	-
	R04 (4m) ~ R05 (5m)	-
	R06 (6m) ~ R10 (10m)	-
Connectors on Both Ends Robot Cable	RW01 (1m) ~ RW03 (3m)	-
	RW04 (4m) ~ RW05 (5m)	-
	RW06 (6m) ~ RW10 (10m)	-

< > values are applicable to the SE type.
 * See page A-39 for cables for maintenance.

④ Option List

Name	Option Code	See Page	Standard Price
Brake	B	→ A-25	-
Reversed-home	NM	→ A-33	-

Actuator Specifications

Item	Description
Drive System	Ball screw Ø10mm C10 grade
Positioning Repeatability	±0.02mm
Lost Motion	0.1mm or less
Allowable Static Moment	Ma: 38.3N·m Mb: 54.7N·m Mc: 81.0N·m
Allowable Dynamic Moment(*)	Ma: 8.9N·m Mb: 12.7N·m Mc: 18.6N·m
Overhang Load Length	150mm or less along Ma; 150mm or less along Mb/Mc
Ambient Operating Temp./Humidity	0~40°C, 85%RH or less (Non-condensing)

(*) Based on 5,000km travel life.

Directions of Allowable Load Moments

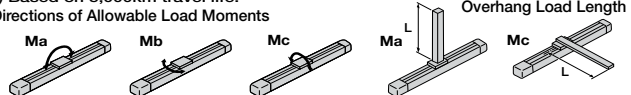

Dimensions

CAD drawings can be downloaded from IAI website. www.intelligentactuator.com



* For the reversed-home model, the dimensions (distance from the ME to home) on the motor-side and that on the opposite side are flipped.

For Special Orders P. A-9

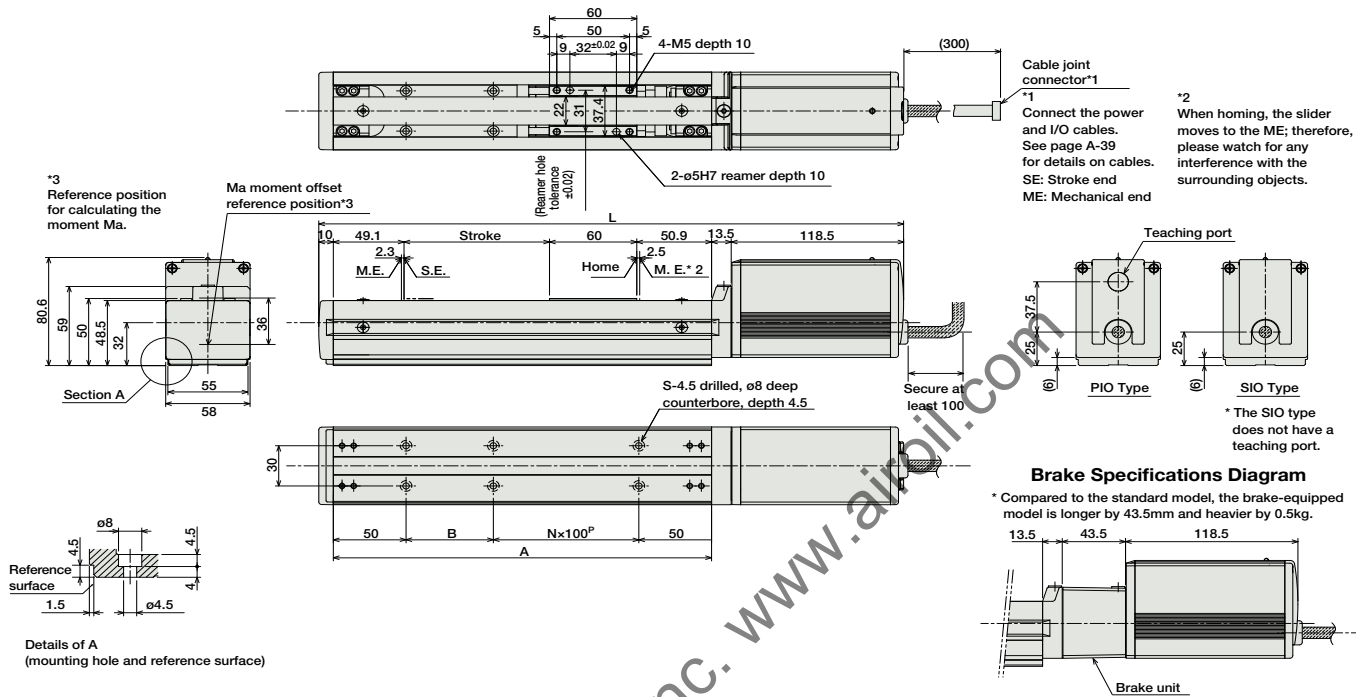

■ Dimensions/Weight by Stroke

Stroke	50	100	150	200	250	300	350	400	450	500	550	600
L	352	402	452	502	552	602	652	702	752	802	852	902
A	210	260	310	360	410	460	510	560	610	660	710	760
B	10	60	10	60	10	60	10	60	10	60	10	60
N	1	1	2	2	3	3	4	4	5	5	6	6
S	6	6	8	8	10	10	12	12	14	14	16	16
Weight (kg)	1.9	2.0	2.1	2.3	2.4	2.6	2.7	2.8	3.0	3.1	3.3	3.4

I/O Type (Controller built into the actuator)

② I/O type

The integrated controller in the ERC2 Series can be selected from the following 3 types based on the type of external input and output (I/O). Select the type according to your application.

Name	External View	Model	Description	Max. Positioning Points	Input Voltage	Power Supply Capacity	Standard Price	See Page
PIO Type (NPN Specification)		ERC2-SA6C-I-PM-□-□-NP-□-□	Simple control type with up to 16-point positioning	16	DC24V	2A Max.	-	→ P515
PIO Type (PNP Specification)		ERC2-SA6C-I-PM-□-□-PN-□-□	Supports the PNP I/O commonly used overseas.	16				
SIO Type		ERC2-SA6C-I-PM-□-□-SE-□-□	Field Network Connection Serial (Gateway unit used)	64				

- Slider Type
- Mini
- Standard
- Controllers Integrated
- Rod Type
- Mini
- Standard
- Controllers Integrated
- Table/Arm/Flat Type
- Mini
- Standard
- Controllers Integrated
- Gripper/Rotary Type
- Linear Servo Type
- Cleanroom Type
- Splash-Proof
- Controllers
- PMEC/AMEC
- PSEP/ASEP
- ROBO NET
- ERC2
- PCON
- ACON
- SCON
- PSEL
- ASEL
- SSEL
- XSEL
- Pulse Motor
- Servo Motor (24V)
- Servo Motor (200V)
- Linear Servo Motor

ERC2-SA7C

Controller-Integrated Slider Type 68mm Width Pulse Motor Straight Type

■ Configuration: **ERC2** — **SA7C** — **I** — **PM** — — — — —

Series — Type — Encoder — Motor — Lead — Stroke — I/O Type — Cable Length — Option

I: Incremental PM: Pulse motor 16: 16mm 50: 50mm NP: PIO N: None P: 1m B: Brake
 8: 8mm 4: 4mm 600: 600mm (50mm pitch increments) (NPN) Type S: 3m M: 5m NM: Reversed-home
 PSEL X: Custom Length W: Cable with connectors on both ends
 PN: PIO (PNP) Type R: Robot cable SE: SIO Type RW: Robot cable with connectors on both ends

* See page Pre-35 for explanation of each code that makes up the configuration name.

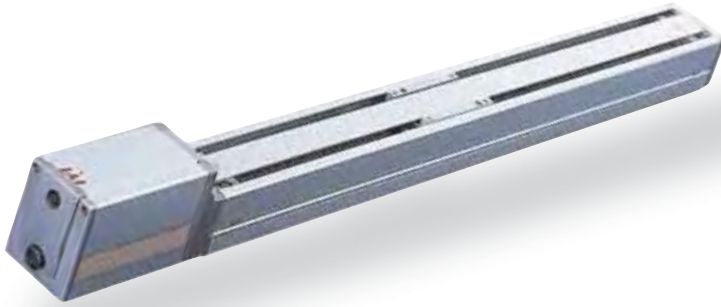

Technical References P. A-5



- (1) When the stroke increases, the maximum speed will drop to prevent the ball screw from reaching the critical rotational speed. Use the actuator specification table below to check the maximum speed at the stroke you desire.
- (2) Since the ERC2 series use a pulse motor, the load capacity decreases at high speeds. Check in the Speed vs. Load Capacity graph to see if your desired speed and load capacity are supported.
- (3) The load capacity is based on operation at an acceleration of 0.3G (0.2G for the 3mm-lead model, or when using vertically). These values are the upper limits for the acceleration.

■ Speed vs. Load Capacity
 Due to the characteristics of the pulse motor, the ERC2 series' load capacity decreases at high speeds. In the table below, check if your desired speed and load capacity are supported.

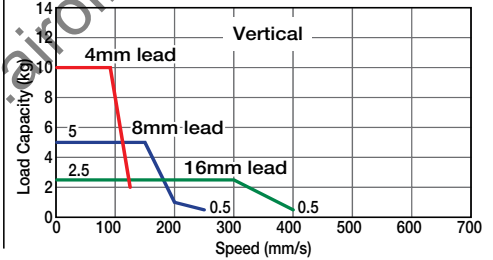
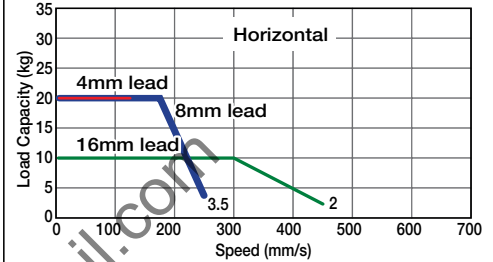

Actuator Specifications				
■ Lead and Load Capacity		(Note 1) Please note that the maximum load capacity decreases as the speed increases.		■ Stroke and Maximum Speed
Model	Lead (mm)	Max. Load Capacity (Note 1)	Stroke (mm)	Stroke
		Horizontal (kg)	Vertical (kg)	50 ~ 600 (50mm increments)
ERC2-SA7C-I-PM-16-①-②-③-④	16	~ 10	~ 2.5	16
ERC2-SA7C-I-PM-8-①-②-③-④	8	~ 20	~ 5	8
ERC2-SA7C-I-PM-4-①-②-③-④	4	20	~ 10	4

Legend ① Stroke ② I/O type ③ Cable length ④ Options

※ < > apply to vertical setting. (Unit: mm/s)

① Stroke List

Stroke (mm)	Standard Price
50	-
100	-
150	-
200	-
250	-
300	-
350	-
400	-
450	-
500	-
550	-
600	-

③ Cable List

Type	Cable Symbol	Standard Price
Standard	P (1m)	-
	S (3m)	-
	M (5m)	-
Special Lengths	X06 (6m) ~ X10 (10m)	-
Connectors on Both Ends	W01(1m) ~ W03(3m)	-
	W04(4m) ~ W05(5m)	-
	W06(6m) ~ W10(10m)	-
Robot Cable	R01 (1m) ~ R03 (3m)	-
	R04 (4m) ~ R05 (5m)	-
	R06 (6m) ~ R10 (10m)	-
Connectors on Both Ends Robot Cable	RW01 (1m) ~ RW03 (3m)	-
	RW04 (4m) ~ RW05 (5m)	-
	RW06 (6m) ~ RW10 (10m)	-

④ Option List

Name	Option Code	See Page	Standard Price
Brake	B	→ A-25	-
Reversed-home	NM	→ A-33	-

Actuator Specifications

Item	Description
Drive System	Ball screw ø12mm C10 grade
Positioning Repeatability	±0.02mm
Lost Motion	0.1mm or less
Allowable Static Moment	Ma: 63.0N-m Mb: 90.0N-m Mc: 132.5N-m
Allowable Dynamic Moment(*)	Ma: 13.8N-m Mb: 19.7N-m Mc: 29.0N-m
Overhang Load Length	150mm or less along Ma; 150mm or less along Mb/Mc
Ambient Operating Temp./Humidity	0~40°C, 85%RH or less (Non-condensing)

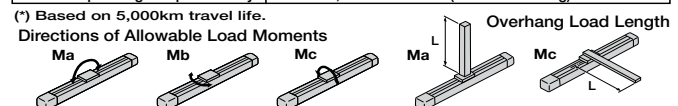

Dimensions

CAD drawings can be downloaded from IAI website. www.intelligentactuator.com



※ For the reversed-home model, the dimensions (distance from the ME to home) on the motor-side and that on the opposite side are flipped.

For Special Orders P. A-9

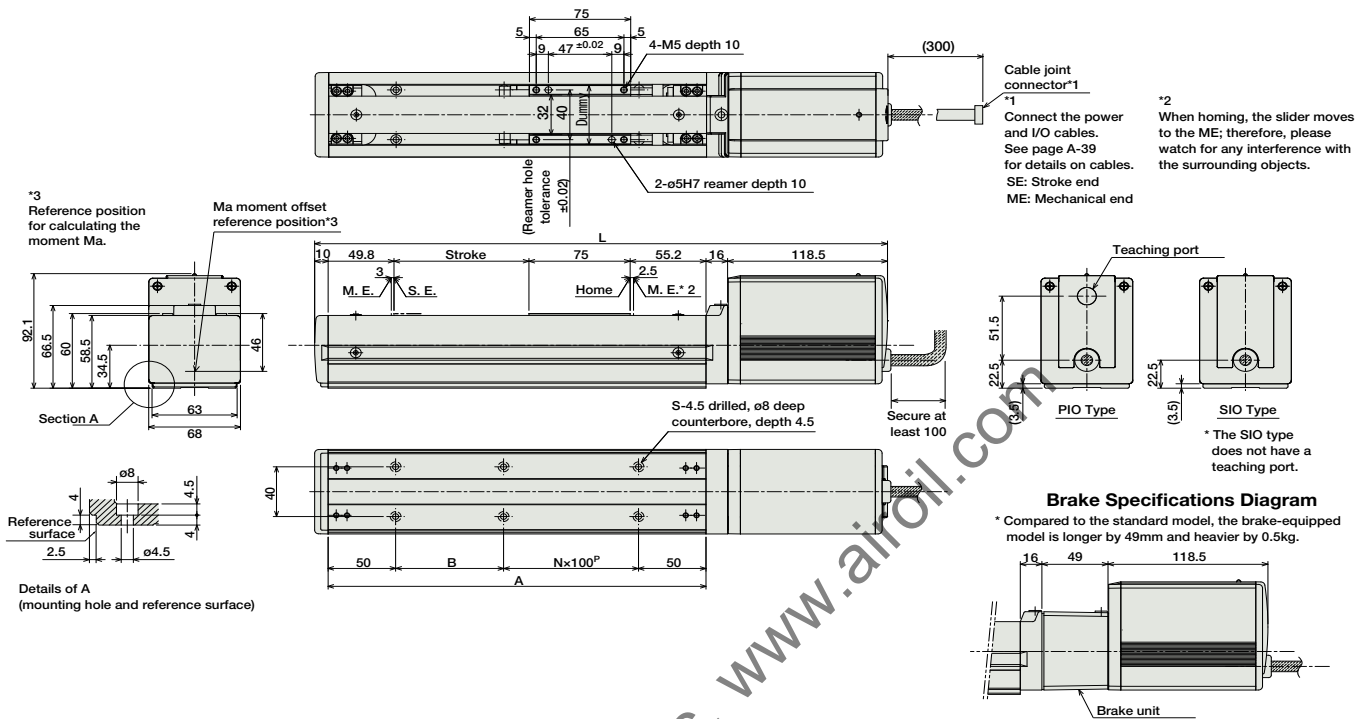

■ Dimensions/Weight by Stroke

Stroke	50	100	150	200	250	300	350	400	450	500	550	600
L	374.5	424.5	474.5	524.5	574.5	624.5	674.5	724.5	774.5	824.5	874.5	924.5
A	230	280	330	380	430	480	530	580	630	680	730	780
B	30	80	30	80	30	80	30	80	30	80	30	80
N	1	1	2	2	3	3	4	4	5	5	6	6
S	6	6	8	8	10	10	12	12	14	14	16	16
Weight (kg)	3.1	3.2	3.4	3.6	3.7	3.9	4.0	4.2	4.3	4.5	4.6	4.8

I/O Type (Controller built into the actuator)

② I/O type

The integrated controller in the ERC2 Series can be selected from the following 3 types based on the type of external input and output (I/O). Select the type according to your application.

Name	External View	Model	Description	Max. Positioning Points	Input Voltage	Power Supply Capacity	Standard Price	See Page
PIO Type (NPN Specification)		ERC2-SA7C-I-PM-□-□-NP-□-□	Simple control type with up to 16-point positioning	16	DC24V	2A Max.	-	→ P515
PIO Type (PNP Specification)		ERC2-SA7C-I-PM-□-□-PN-□-□	Supports the PNP I/O commonly used overseas.	16				
SIO Type		ERC2-SA7C-I-PM-□-□-SE-□-□	Field Network Connection Serial (Gateway unit used)	64				

- Slider Type
- Mini
- Standard
- Controllers Integrated
- Rod Type
- Mini
- Standard
- Controllers Integrated
- Table/Arm/Flat Type
- Mini
- Standard
- Gripper/Rotary Type
- Linear Servo Type
- Cleanroom Type
- Splash-Proof
- Controllers
- PMEC/AMEC
- PSEP/ASEP
- ROBO NET
- ERC2
- PCON
- ACON
- SCON
- PSEL
- ASEL
- SSEL
- XSEL
- Pulse Motor
- Servo Motor (24V)
- Servo Motor (200V)
- Linear Servo Motor

RCA2-SA3C ROBO Cylinder Slider Type 32mm Width Servo Motor Coupled

■ Configuration: **RCA2** — **SA3C** — **I** — **10** — — — — —

Series — Type — Encoder — Motor — Lead — Stroke — Compatible Controllers — Cable Length — Option

I: Incremental
* The Simple absolute encoder models are labeled as "I".

10P: 10W Servo motor

6 :6mm
4 :4mm
2 :2mm

50: 50mm
300:300mm (50mm pitch increments)

A1: ACON
RACON
ASEL
A3: AMEC
ASEP

N : None
P : 1m
S : 3m
M : 5m
X : Custom Length

See Options below

* See page Pre-35 for explanation of each code that makes up the configuration name.

Power-saving

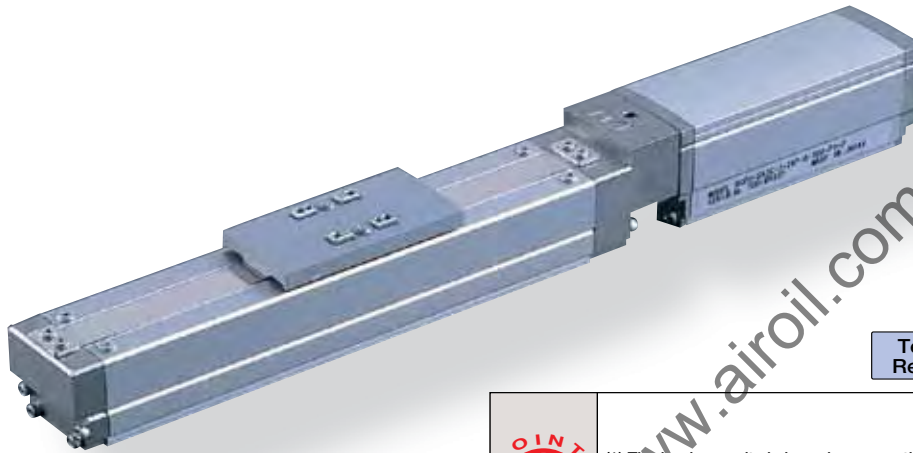

Technical References P. A-5

POINT
Notes on Selection

(1) The load capacity is based on operation at an acceleration of 0.3G (2G for the 2mm-lead model, or when used vertically). These values are the upper limits for the acceleration.

Actuator Specifications

■ Lead and Load Capacity

Model	Motor Output (W)	Lead (mm)	Max. Load Capacity		Rated Thrust (N)	Stroke (mm)
			Horizontal (kg)	Vertical (kg)		
RCA2-SA3C-I-10-6-①-②-③-④	10	6	1	0.5	28	50 ~ 300 (50mm increments)
RCA2-SA3C-I-10-4-①-②-③-④		4	2	1	43	
RCA2-SA3C-I-10-2-①-②-③-④		2	3	1.5	85	

■ Stroke and Maximum Speed

Stroke Lead	50 ~ 300 (50mm increments)	
	Stroke	50 ~ 300 (50mm increments)
6	300	
4	200	
2	100	

Legend ① Stroke ② Compatible controller ③ Cable length ④ Options (Unit: mm/s)

① Stroke List

Stroke (mm)	Standard Price	
	With cover (standard)	No cover (Option)
50	-	-
100	-	-
150	-	-
200	-	-
250	-	-
300	-	-

③ Cable List

Type	Cable Symbol	Standard Price
Standard (Robot Cables)	P (1m)	-
	S (3m)	-
	M (5m)	-
Special Lengths	X06 (6m) ~ X10 (10m)	-
	X11 (11m) ~ X15 (15m)	-
	X16 (16m) ~ X20 (20m)	-
		-

* The standard cable for the RCA2 is the robot cable.

* For cables for maintenance, see page A-39.

④ Option List

Name	Option Code	See Page	Standard Price
Brake-Equipped	B	→ A-25	-
Cable Exit Direction (Top)	CJT	→ A-25	-
Cable Exit Direction (Right)	CJR	→ A-25	-
Cable Exit Direction (Left)	CJL	→ A-25	-
Cable Exit Direction (Bottom)	CJB	→ A-25	-
Power-saving	LA	→ A-32	-
No Cover	NCO	→ A-33	-
Reversed-home	NM	→ A-33	-

Actuator Specifications

Item	Description
Drive System	Ball screw Ø6mm C10 grade
Positioning Repeatability	±0.02mm
Lost Motion	0.1mm or less
Base	Material: Aluminum (special alumite treated)
Allowable Static Moment	Ma: 5.0N·m Mb: 7.1N·m Mc: 7.9N·m
Allowable Dynamic Moment(*)	Ma: 1.96N·m Mb: 2.84N·m Mc: 3.14N·m
Overhang Load Length	100mm or less
Ambient Operating Temp./Humidity	0~40°C, 85% RH or less (non-condensing)

(*) Based on 5,000km travel life.

Directions of Allowable Load Moments

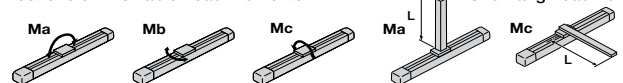

Dimensions

CAD drawings can be downloaded from IAI website. www.intelligentactuator.com

For Special Orders P. A-9

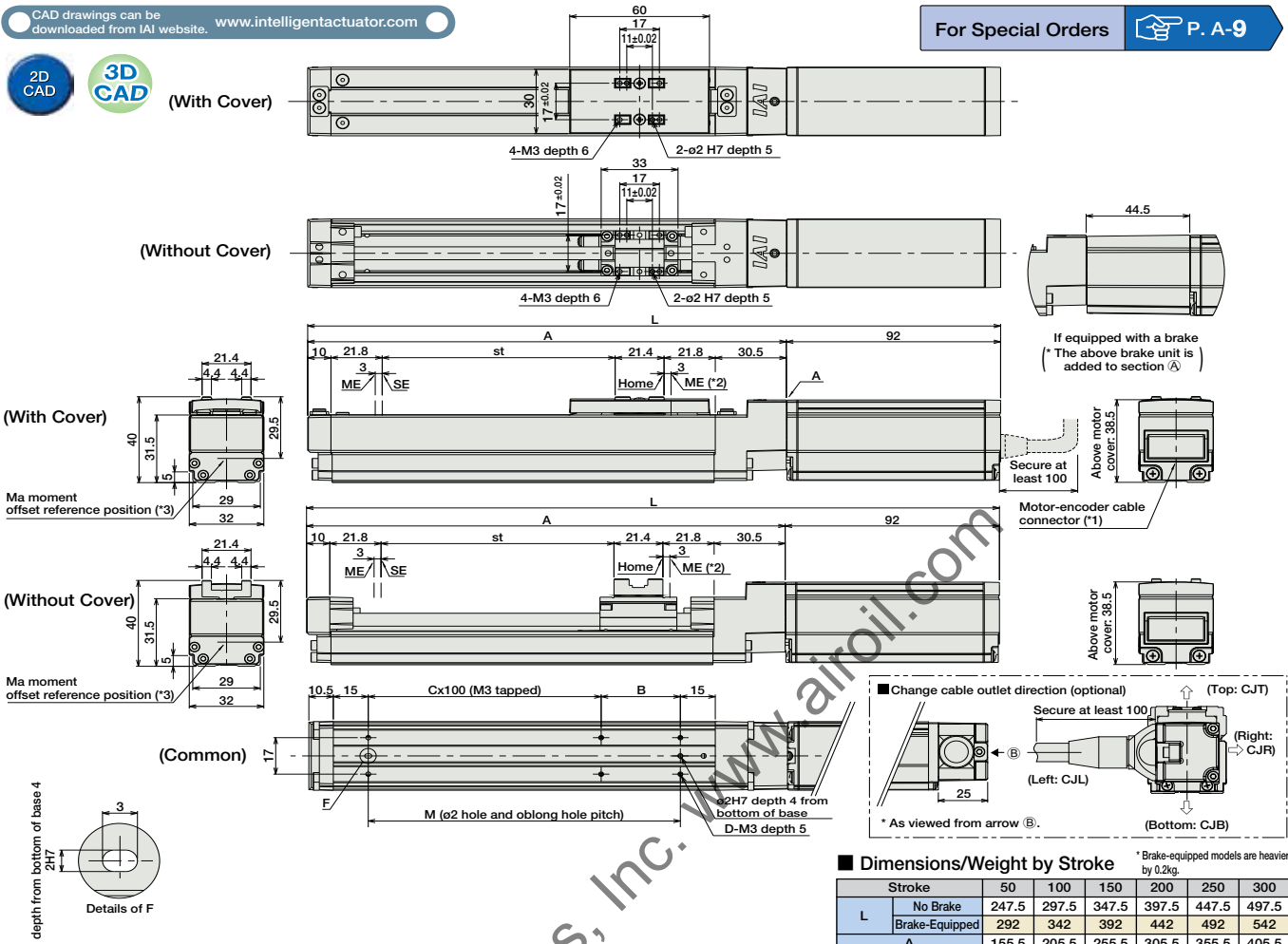

- (*1) A motor-encoder cable (integrated) is connected here. (For details on cables for maintenance, see page A-39.)
- (*2) After homing, the slider moves to the ME, therefore, please watch for any interference with surrounding objects.
ME : Mechanical end
SE : Stroke end
- (*3) Reference position for calculating the moment Ma

Dimensions/Weight by Stroke

* Brake-equipped models are heavier by 0.2kg.

Stroke	Stroke						
	50	100	150	200	250	300	
L	No Brake	247.5	297.5	347.5	397.5	447.5	497.5
	Brake-Equipped	292	342	392	442	492	542
A	155.5	205.5	255.5	305.5	355.5	405.5	
B	84	34	84	34	84	34	
C	0	1	1	2	2	3	
D	4	6	6	8	8	10	
M	84	134	184	234	284	334	
Weight (kg)	With Cover	0.6	0.6	0.7	0.8	0.8	0.9
	No Cover	0.5	0.6	0.6	0.7	0.7	0.8

Compatible Controllers

The RCA2 series actuators can operate with the controllers below. Select the controller according to your usage.

Name	External View	Model	Description	Max. Positioning Points	Input Voltage	Power Supply Capacity	Standard Price	See Page
Solenoid Valve Type		AMEC-C-10①-NP-2-1	Easy-to-use controller, even for beginners	3 points	AC100V	2.4A rated	—	→ P477
		ASEP-C-10①-NP-2-0	Operable with same signal as solenoid valve. Supports both single and double solenoid types. No homing necessary with simple absolute type.					
Splash-Proof Solenoid Valve Type		ASEP-CW-10①-NP-2-0						→ P487
Positioner Type		ACON-C-10①-NP-2-0	Positioning is possible for up to 512 points	512 points	DC24V	(Standard) 1.3A rated 4.4A max.	—	→ P535
Safety-Compliant Positioner Type		ACON-CG-10①-NP-2-0						
Pulse Train Input Type (Differential Line Driver)		ACON-PL-10①-NP-2-0	Pulse train input type with differential line driver support	(-)	DC24V	(Power-saving) 1.3A rated 2.5A max.	—	→ P535
Pulse Train Input Type (Open Collector)		ACON-PO-10①-NP-2-0	Pulse train input type with open collector support					
Serial Communication Type		ACON-SE-10①-N-0-0	Dedicated to serial communication	64 points				
Field Network Type		RACON-10①	Dedicated to field network	768 points				→ P503
Program Control Type		ASEL-C-1-10①-NP-2-0	Programmed operation is possible Can operate up to 2 axes	1500 points				→ P567

* This is for the single-axis ASEL.
* ① is replaced with the code "LA" when support for power-saving is specified.

RCA2-SA4C ROBO Cylinder Slider Type 40mm Width Servo Motor Coupled

■ Configuration: **RCA2** — **SA4C** — **I** — **20** — — — — —

Series — Type — Encoder — Motor — Lead — Stroke — Compatible Controllers — Cable Length — Option

I: Incremental
* The Simple absolute encoder models are labeled as "I".

20P: 20W Servo motor

10: 6mm
5: 4mm
2.5: 2mm

50: 50mm
500: 500mm (50mm pitch increments)

A1: ACON
RACON
ASEL

A3: AMEC
ASEP

N: None
P: 1m
S: 3m
M: 5m
X : Custom Length

See Options below

* See page Pre-35 for explanation of each code that makes up the configuration name.

Power-saving

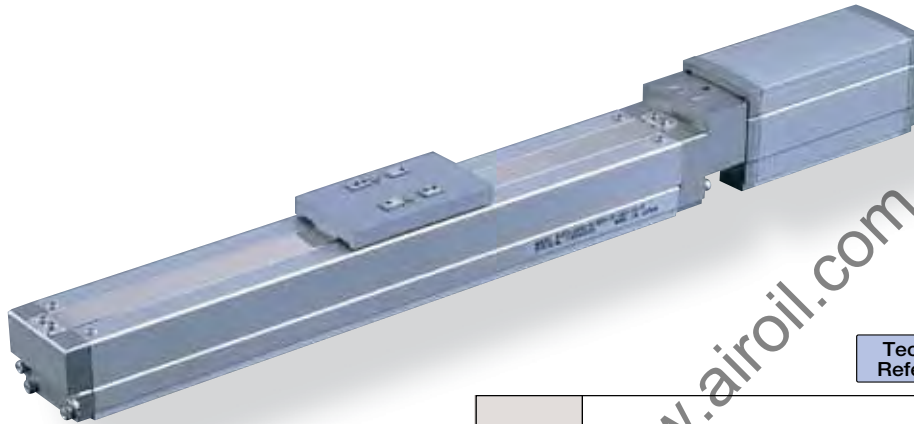

Technical References P. A-5

POINT
Notes on Selection

(1) The load capacity is based on operation at an acceleration of 0.3G (0.2G for the 2.5mm-lead model, or when used vertically). These values are the upper limits for the acceleration.

Actuator Specifications

Lead and Load Capacity

Model	Motor Output (W)	Lead (mm)	Max. Load Capacity		Rated Thrust (N)	Stroke (mm)
			Horizontal (kg)	Vertical (kg)		
RCA2-SA4C-I-20-10-①-②-③-④	20	10	2	1	34	50 ~ 500 (50mm increments)
RCA2-SA4C-I-20-5-①-②-③-④		5	4	1.5	68	
RCA2-SA4C-I-20-2.5-①-②-③-④		2.5	6	3	136	

Stroke and Maximum Speed

Stroke Lead	50 ~ 500 (50mm increments)	
	Stroke	Maximum Speed
10	500	
5	250	
2.5	125	

Legend ① Stroke ② Compatible controller ③ Cable length ④ Options

(Unit: mm/s)

① Stroke List

Stroke (mm)	Standard Price	
	With cover (standard)	No cover (Option)
50	-	-
100	-	-
150	-	-
200	-	-
250	-	-
300	-	-
350	-	-
400	-	-
450	-	-
500	-	-

③ Cable List

Type	Cable Symbol	Standard Price
Standard (Robot Cables)	P (1m)	-
	S (3m)	-
	M (5m)	-
Special Lengths	X06 (6m) ~ X10 (10m)	-
	X11 (11m) ~ X15 (15m)	-
	X16 (16m) ~ X20 (20m)	-
		-

* The standard cable for the RCA2 is the robot cable.

* For cables for maintenance, see page A-39.

④ Option List

Name	Option Code	See Page	Standard Price
Brake-Equipped	B	→ A-25	-
Cable Exit Direction (Top)	CJT	→ A-25	-
Cable Exit Direction (Right)	CJR	→ A-25	-
Cable Exit Direction (Left)	CJL	→ A-25	-
Cable Exit Direction (Bottom)	CJB	→ A-25	-
Power-saving	LA	→ A-32	-
No Cover	NCO	→ A-33	-
Reversed-home	NM	→ A-33	-

Actuator Specifications

Item	Description
Drive System	Ball screw Ø8mm C10 grade
Positioning Repeatability	±0.02mm
Lost Motion	0.1mm or less
Base	Material: Aluminum (special alumite treated)
Allowable Static Moment	Ma: 6.8N·m Mb: 9.7N·m Mc: 13.3N·m
Allowable Dynamic Moment(*)	Ma: 3.04N·m Mb: 4.31N·m Mc: 5.00N·m
Overhang Load Length	120mm or less
Ambient Operating Temp./Humidity	0~40°C, 85% RH or less (non-condensing)

(*) Based on 5,000km travel life.

Directions of Allowable Load Moments



Dimensions

CAD drawings can be downloaded from IAI website. www.intelligentactuator.com

For Special Orders P. A-9

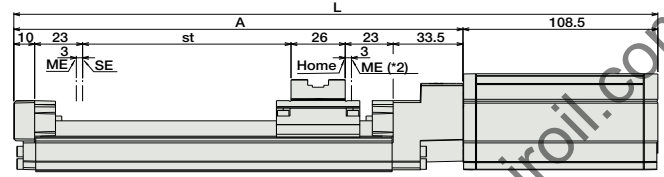
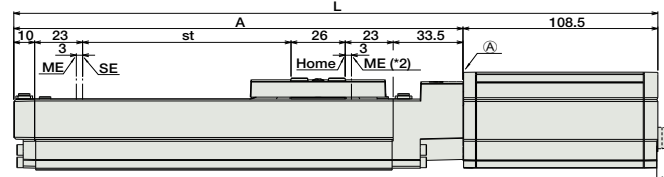
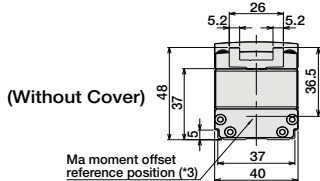
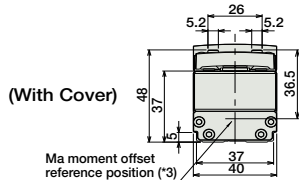
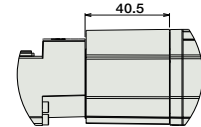
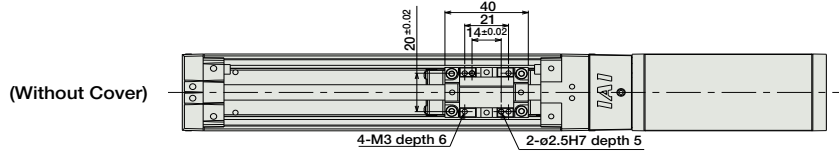
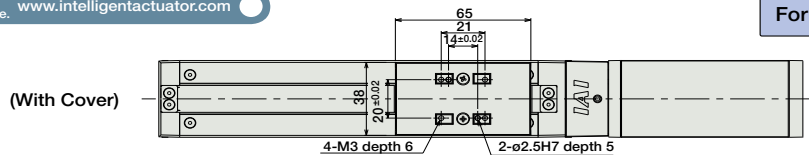

If equipped with a brake (* The above brake unit is added to section (A).)

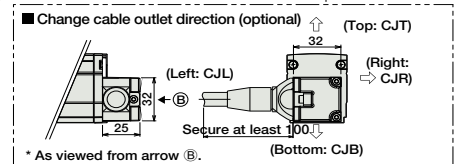
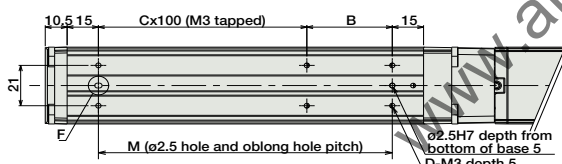
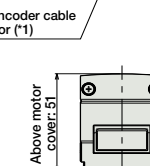
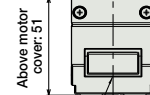

2.5H7 depth from bottom of base 5

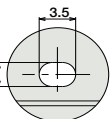

Details of F

(*1) A motor-encoder cable (integrated) is connected here. (See page A-39 for details on cables)

(*2) After homing, the slider moves to the ME, therefore, please watch for any interference with surrounding objects.

ME : Mechanical end
SE : Stroke end

(*3) Reference position for calculating the moment Ma

Dimensions/Weight by Stroke

* Brake-equipped models are heavier by 0.3kg.

Stroke	50	100	150	200	250	300	350	400	450	500
	No Brake	274	324	374	424	474	524	574	624	674
Brake-Equipped	314.5	364.5	414.5	464.5	514.5	564.5	614.5	664.5	714.5	764.5
A	165.5	215.5	265.5	315.5	365.5	415.5	465.5	515.5	565.5	615.5
B	91	41	91	41	91	41	91	41	91	41
C	0	1	1	2	2	3	3	4	4	5
D	4	6	6	8	8	10	10	12	12	14
M	91	141	191	241	291	341	391	441	491	541
Weight (kg)	With Cover	0.9	1	1.1	1.1	1.2	1.3	1.4	1.5	1.6
	No Cover	0.8	0.9	1	1	1.1	1.2	1.3	1.3	1.4

Compatible Controllers

The RCA2 series actuators can operate with the controllers below. Select the controller according to your usage.

Name	External View	Model	Description	Max. Positioning Points	Input Voltage	Power Supply Capacity	Standard Price	See Page
Solenoid Valve Type		AMEC-C-20Si①-NP-2-1	Easy-to-use controller, even for beginners	3 points	AC100V	2.4A rated	—	→ P477
		ASEP-C-20Si①-NP-2-0	Operable with same signal as solenoid valve. Supports both single and double solenoid types. No homing necessary with simple absolute type.					
Splash-Proof Solenoid Valve Type		ASEP-CW-20Si①-NP-2-0						→ P487
Positioner Type		ACON-C-20Si①-NP-2-0	Positioning is possible for up to 512 points	512 points	DC24V	(Standard) 1.7A rated 5.1A max.	—	→ P535
Safety-Compliant Positioner Type		ACON-CG-20Si①-NP-2-0						
Pulse Train Input Type (Differential Line Driver)		ACON-PL-20Si①-NP-2-0	Pulse train input type with differential line driver support	—	DC24V	(Power-saving) 1.7A rated 3.4A max.	—	→ P535
Pulse Train Input Type (Open Collector)		ACON-PO-20Si①-NP-2-0	Pulse train input type with open collector support					
Serial Communication Type		ACON-SE-20Si①-N-0-0	Dedicated to serial communication	64 points				
Field Network Type		RACON-20S①	Dedicated to field network	768 points				→ P503
Program Control Type		ASEL-C-1-20Si①-NP-2-0	Programmed operation is possible Can operate up to 2 axes	1500 points				→ P567

* This is for the single-axis ASEL.

* ① is replaced with the code "LA" when support for power-saving is specified.

RCA2-SA5C ROBO Cylinder Slider Type 50mm Width Servo Motor Coupled

■ Configuration: **RCA2** — **SA5C** — **I** — **20** — — — — —

Series — Type — Encoder — Motor — Lead — Stroke — Compatible Controllers — Cable Length — Option

I: Incremental
* The Simple absolute encoder models are labeled as "I".

20P: 20W Servo motor

12: 12mm
6: 6mm
3: 3mm

50: 50mm
800: 800mm (50mm pitch increments)

A1: ACON
RACON
ASEL
A3: AMEC
ASEP

N : None
P : 1m
S : 3m
M : 5m
X : Custom Length

See Options below

* See page Pre-35 for explanation of each code that makes up the configuration name.

Power-saving

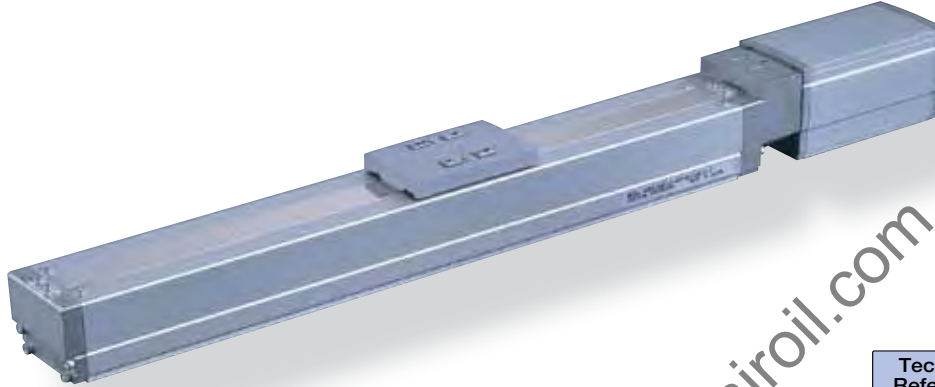

Technical References P. A-5

POINT
Notes on Selection

(1) The load capacity is based on operation at an acceleration of 0.3G (0.2G for the 3mm-lead model, or when used vertically). These values are the upper limits for the acceleration.

Actuator Specifications

■ Lead and Load Capacity

Model	Motor Output (W)	Lead (mm)	Max. Load Capacity Horizontal (kg)	Max. Load Capacity Vertical (kg)	Rated Thrust (N)	Stroke (mm)
RCA2-SA5C-I-20-12-①-②-③-④	20	12	3	1	17	50 ~ 800 (50mm increments)
RCA2-SA5C-I-20-6-①-②-③-④		6	6	1.5	34	
RCA2-SA5C-I-20-3-①-②-③-④		3	9	3	68	

■ Stroke and Maximum Speed

Stroke Lead	50 ~ 550 (50mm increments)	600 (mm)	650 (mm)	700 (mm)	750 (mm)	800 (mm)
12	600	570	490	425	370	330
6	300	285	245	210	185	165
3	150	140	120	105	90	80

Legend ① Stroke ② Compatible controller ③ Cable length ④ Options

(Unit: mm/s)

① Stroke List

Stroke (mm)	Standard Price	
	With cover (standard)	No cover (Option)
50	-	-
100	-	-
150	-	-
200	-	-
250	-	-
300	-	-
350	-	-
400	-	-
450	-	-
500	-	-
550	-	-
600	-	-
650	-	-
700	-	-
750	-	-
800	-	-

③ Cable List

Type	Cable Symbol	Standard Price
Standard (Robot Cables)	P (1m)	-
	S (3m)	-
	M (5m)	-
Special Lengths	X06 (6m) ~ X10 (10m)	-
	X11 (11m) ~ X15 (15m)	-
	X16 (16m) ~ X20 (20m)	-
		-

* The standard cable for the RCA2 is the robot cable.

* For cables for maintenance, see page A-39.

④ Option List

Name	Option Code	See Page	Standard Price
Brake-Equipped	B	→ A-25	-
Cable Exit Direction (Top)	CJT	→ A-25	-
Cable Exit Direction (Right)	CJR	→ A-25	-
Cable Exit Direction (Left)	CJL	→ A-25	-
Cable Exit Direction (Bottom)	CJB	→ A-25	-
Power-saving	LA	→ A-32	-
No Cover	NCO	→ A-33	-
Reversed-home	NM	→ A-33	-

Actuator Specifications

Item	Description
Drive System	Ball screw Ø10mm C10 grade
Positioning Repeatability	±0.02mm
Lost Motion	0.1mm or less
Base	Material: Aluminum (special alumite treated)
Allowable Static Moment	Ma: 10.2N·m Mb: 14.6N·m Mc: 22.4N·m
Allowable Dynamic Moment(*)	Ma: 3.92N·m Mb: 5.58N·m Mc: 8.53N·m
Overhang Load Length	130mm or less
Ambient Operating Temp./Humidity	0~40°C, 85% RH or less (non-condensing)

(*) Based on 5,000km travel life.

Directions of Allowable Load Moments

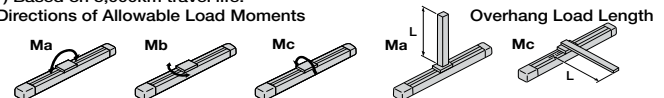

Dimensions

CAD drawings can be downloaded from IAI website. www.intelligentactuator.com



For Special Orders P. A-9

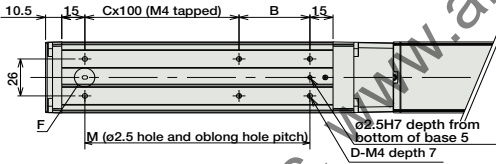
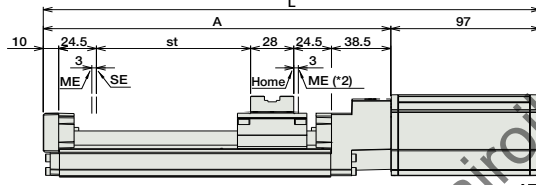
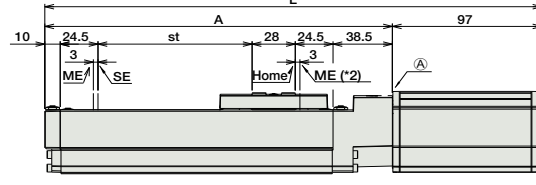
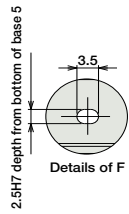
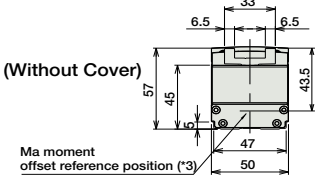
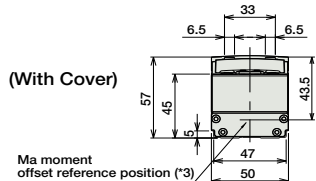
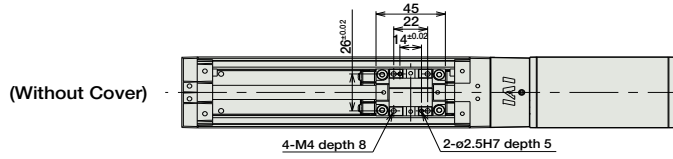
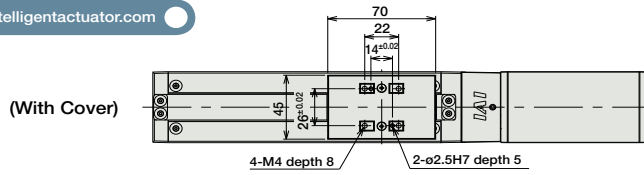

- (*1) An motor-encoder cable (integrated) is connected here. (See page A-39 for details on cables.)
- (*2) After homing, the slider moves to the ME, therefore, please watch for any interference with surrounding objects.
ME : Mechanical end
SE : Stroke end
- (*3) Reference position for calculating the moment Ma

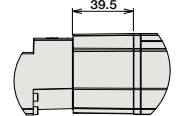

If equipped with a brake
* The above brake unit is added to section A.

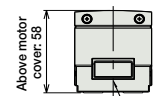

Motor-encoder cable connector (*1)

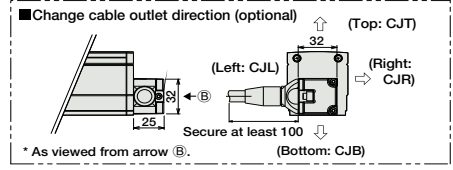
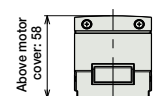

■ Dimensions/Weight by Stroke

* Brake-equipped models are heavier by 0.4kg.

Stroke	50	100	150	200	250	300	350	400	450	500	550	600	650	700	750	800	
L	No Brake	272.5	322.5	372.5	422.5	472.5	522.5	572.5	622.5	672.5	722.5	772.5	822.5	872.5	922.5	972.5	1022.5
	Brake-Equipped	312	362	412	462	512	562	612	662	712	762	812	862	912	962	1012	1062
A	175.5	225.5	275.5	325.5	375.5	425.5	475.5	525.5	575.5	625.5	675.5	725.5	775.5	825.5	875.5	925.5	
B	96	46	96	46	96	46	96	46	96	46	96	46	96	46	96	46	
C	0	1	2	2	3	3	4	4	5	5	6	6	7	7	8		
D	6	6	8	8	10	10	12	12	14	14	16	16	18	18	20		
M	96	146	196	246	296	346	396	446	496	546	596	646	696	746	796	846	
Weight (kg)	With Cover	1.2	1.4	1.5	1.6	1.8	1.9	2	2.2	2.3	2.4	2.6	2.7	2.8	3.0	3.1	3.2
	No Cover	1.1	1.3	1.4	1.5	1.6	1.7	1.8	1.9	2	2.1	2.2	2.3	2.4	2.5	2.6	2.7

② Compatible Controllers

The RCA2 series actuators can operate with the controllers below. Select the controller according to your usage.

Name	External View	Model	Description	Max. Positioning Points	Input Voltage	Power Supply Capacity	Standard Price	See Page
Solenoid Valve Type		AMEC-C-20①-NP-2-1	Easy-to-use controller, even for beginners	3 points	AC100V	2.4A rated	—	→ P477
		ASEP-C-20①-NP-2-0	Operable with same signal as solenoid valve. Supports both single and double solenoid types. No homing necessary with simple absolute type.					
Splash-Proof Solenoid Valve Type		ASEP-CW-20①-NP-2-0						→ P487
Positioner Type		ACON-C-20①-NP-2-0	Positioning is possible for up to 512 points	512 points	DC24V	(Standard) 1.3A rated 4.4A max.	—	→ P535
Safety-Compliant Positioner Type		ACON-CG-20①-NP-2-0						
Pulse Train Input Type (Differential Line Driver)		ACON-PL-20①-NP-2-0	Pulse train input type with differential line driver support	(-)	DC24V	(Power-saving) 1.3A rated 2.5A max.	—	→ P535
Pulse Train Input Type (Open Collector)		ACON-PO-20①-NP-2-0	Pulse train input type with open collector support					
Serial Communication Type		ACON-SE-20①-N-0-0	Dedicated to serial communication	64 points				
Field Network Type		RACON-20①	Dedicated to field network	768 points				→ P503
Program Control Type		ASEL-C-1-20①-NP-2-0	Programmed operation is possible Can operate up to 2 axes	1500 points				→ P567

* This is for the single-axis ASEL.
* ① is replaced with the code "LA" when support for power-saving is specified.

RCA2-SA6C

ROBO Cylinder Slider Type 60mm Width Servo Motor Coupled

■ Configuration: **RCA2** — **SA6C** — **I** — **30** — — — — —

Series — Type — Encoder — Motor — Lead — Stroke — Compatible Controllers — Cable Length — Option

I: Incremental 30P: 30W Servo motor
 * The Simple absolute encoder models are labeled as "I".

12: 12mm 50: 50mm 800: 800mm (50mm pitch increments)
 6: 6mm 3: 3mm

A1: ACON RACON ASEL A3: AMEC ASEPE
 N: None P: 1m S: 3m M: 5m X : Custom Length

See Options below

* See page Pre-35 for explanation of each code that makes up the configuration name.

Power-saving

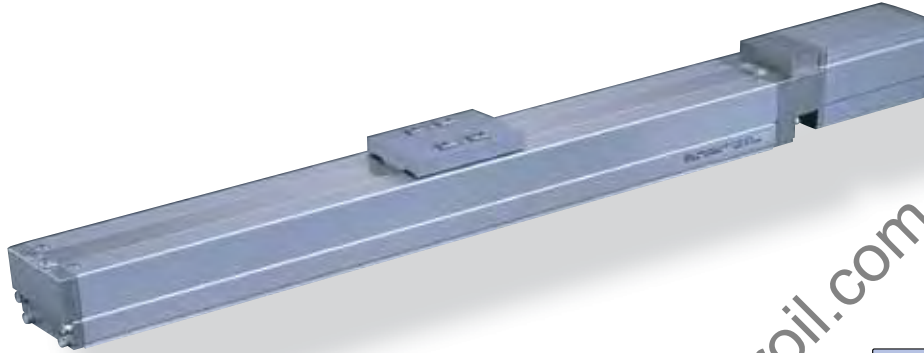

Technical References P. A-5

POINT Notes on Selection

(1) When the stroke increases, the maximum speed will drop to prevent the ball screw from reaching the critical rotational speed. Use the actuator specification table below to check the maximum speed at the stroke you desire.

(2) The load capacity is based on operation at an acceleration of 0.3G (0.2G for the 3mm-lead model, or when used vertically). These values are the upper limits for the acceleration.

Actuator Specifications

■ Lead and Load Capacity

Model	Motor Output (W)	Lead (mm)	Max. Load Capacity		Rated Thrust (N)	Stroke (mm)
			Horizontal (kg)	Vertical (kg)		
RCA2-SA6C-I-30-12-①-②-③-④	30	12	4	1.5	26	50 ~ 800 (50mm increments)
RCA2-SA6C-I-30-6-①-②-③-④		6	7	2	53	
RCA2-SA6C-I-30-3-①-②-③-④		3	10	4	105	

■ Stroke and Maximum Speed

Stroke Lead	50 ~ 550 (50mm increments)	600 (mm)	650 (mm)	700 (mm)	750 (mm)	800 (mm)
	12	600	570	490	425	370
6	300	285	245	210	185	165
3	150	140	120	105	90	80

(Unit: mm/s)

Legend ① Stroke ② Compatible controller ③ Cable length ④ Options

① Stroke List

Stroke (mm)	Standard Price	
	With cover (standard)	No cover (Option)
50	-	-
100	-	-
150	-	-
200	-	-
250	-	-
300	-	-
350	-	-
400	-	-
450	-	-
500	-	-
550	-	-
600	-	-
650	-	-
700	-	-
750	-	-
800	-	-

③ Cable List

Type	Cable Symbol	Standard Price
Standard (Robot Cables)	P (1m)	-
	S (3m)	-
	M (5m)	-
Special Lengths	X06 (6m) ~ X10 (10m)	-
	X11 (11m) ~ X15 (15m)	-
	X16 (16m) ~ X20 (20m)	-

* The standard cable for the RCA2 is the robot cable.
 * For cables for maintenance, see page A-39.

④ Option List

Name	Option Code	See Page	Standard Price
Brake-Equipped	B	→ A-25	-
Cable Exit Direction (Top)	CJT	→ A-25	-
Cable Exit Direction (Right)	CJR	→ A-25	-
Cable Exit Direction (Left)	CJL	→ A-25	-
Cable Exit Direction (Bottom)	CJB	→ A-25	-
Power-saving	LA	→ A-32	-
No Cover	NCO	→ A-33	-
Reversed-home	NM	→ A-33	-

Actuator Specifications

Item	Description
Drive System	Ball screw Ø10mm C10 grade
Positioning Repeatability	±0.02mm
Lost Motion	0.1mm or less
Base	Material: Aluminum (special alumite treated)
Allowable Static Moment	Ma: 17.6N·m Mb: 25.2N·m Mc: 44.5N·m
Allowable Dynamic Moment(*)	Ma: 4.31N·m Mb: 6.17N·m Mc: 10.98N·m
Overhang Load Length	150mm or less
Ambient Operating Temp./Humidity	0~40°C, 85% RH or less (non-condensing)

(*) Based on 5,000km travel life.

Directions of Allowable Load Moments

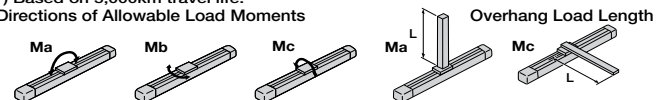

Dimensions

CAD drawings can be downloaded from IAI website. www.intelligentactuator.com



For Special Orders P. A-9

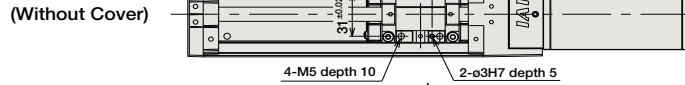
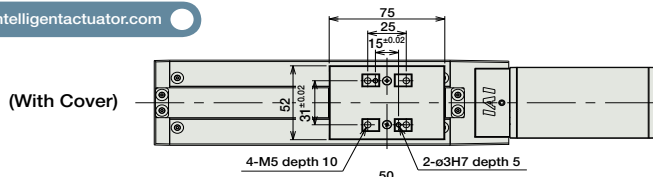

- (*1) A motor-encoder cable (integrated) is connected here. (See page A-39 for details on cables.)
- (*2) After homing, the slider moves to the ME, therefore, please watch for any interference with surrounding objects.
ME : Mechanical end
SE : Stroke end
- (*3) Reference position for calculating the moment Ma

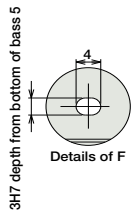
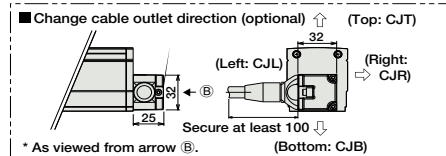
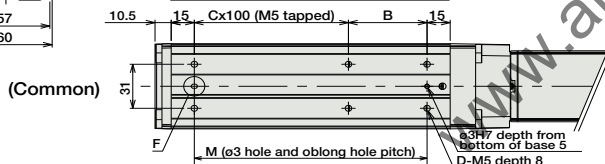
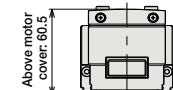
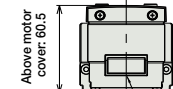
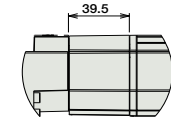
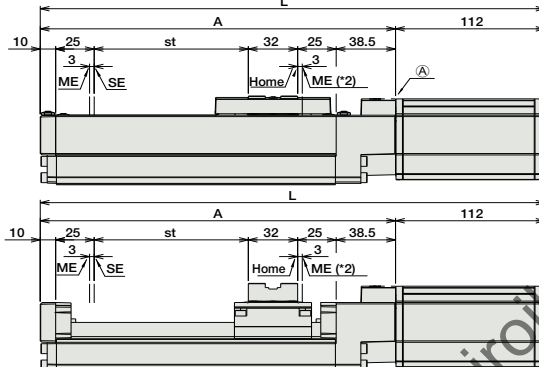
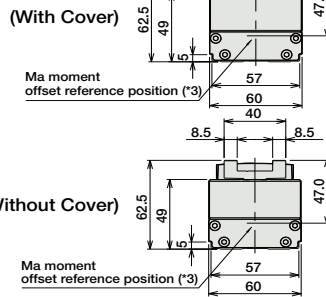

Dimensions/Weight by Stroke

* Brake-equipped models are heavier by 0.4kg.

Stroke	50	100	150	200	250	300	350	400	450	500	550	600	650	700	750	800	
L	No Brake	292.5	342.5	392.5	442.5	492.5	542.5	592.5	642.5	692.5	742.5	792.5	842.5	892.5	942.5	992.5	1042.5
	Brake-equipped	332	382	432	482	532	582	632	682	732	782	832	882	932	982	1032	1082
A		180.5	230.5	280.5	330.5	380.5	430.5	480.5	530.5	580.5	630.5	680.5	730.5	780.5	830.5	880.5	930.5
B		101	151	201	251	301	351	401	451	501	551	601	651	701	751	801	851
C		0	1	2	2	3	3	4	4	5	5	6	6	7	7	8	
D		6	6	8	8	10	10	12	12	14	14	16	16	18	18	20	
M		101	151	201	251	301	351	401	451	501	551	601	651	701	751	801	851
Weight (kg)	With Cover	1.6	1.7	1.9	2.1	2.3	2.4	2.6	2.8	2.9	3.1	3.3	3.5	3.6	3.8	4.0	4.1
	No Cover	1.5	1.6	1.8	1.9	2.1	2.2	2.3	2.5	2.6	2.8	2.9	3.1	3.2	3.4	3.5	3.7

Compatible Controllers

The RCA2 series actuators can operate with the controllers below. Select the controller according to your usage.

Name	External View	Model	Description	Max. Positioning Points	Input Voltage	Power Supply Capacity	Standard Price	See Page
Solenoid Valve Type		AMEC-C-30①-NP-2-1	Easy-to-use controller, even for beginners	3 points	AC100V	2.4A rated	—	→ P477
		ASEP-C-30①-NP-2-0	Operable with same signal as solenoid valve. Supports both single and double solenoid types. No homing necessary with simple absolute type.					
Splash-Proof Solenoid Valve Type		ASEP-CW-30①-NP-2-0						→ P487
Positioner Type		ACON-C-30①-NP-2-0	Positioning is possible for up to 512 points	512 points	DC24V	(Standard) 1.3A rated 4.0A max.	—	→ P535
Safety-Compliant Positioner Type		ACON-CG-30①-NP-2-0						
Pulse Train Input Type (Differential Line Driver)		ACON-PL-30①-NP-2-0	Pulse train input type with differential line driver support	(-)	DC24V	(Power-saving) 1.3A rated 2.2A max.	—	→ P535
Pulse Train Input Type (Open Collector)		ACON-PO-30①-NP-2-0	Pulse train input type with open collector support					
Serial Communication Type		ACON-SE-30①-N-0-0	Dedicated to serial communication	64 points			—	
Field Network Type		RACON-30①	Dedicated to field network	768 points			—	→ P503
Program Control Type		ASEL-C-1-30①-NP-2-0	Programmed operation is possible Can operate up to 2 axes	1500 points			—	→ P567

* This is for the single-axis ASEL.
* ① is replaced with the code "LA" when support for power-saving is specified.

RCA2-SA3R

ROBO Cylinder Slider Type 32mm Width Servo Motor Coupled

■ Configuration: **RCA2** — **SA3R** — **I** — **10** — — — — —

Series — Type — Encoder — Motor — Lead — Stroke — Compatible Controllers — Cable Length — Option

I: Incremental
* Simple absolute encoder models are labeled as "I".

10: 10W Servo motor

6: 6mm
4: 4mm
2: 2mm

50: 50mm
300: 300mm (50mm pitch increments)

A1: ACON
RACON
ASEL
A3: AMEC
ASEP

N: None
P: 1m
S: 3m
M: 5m
X : Custom Length

See Options below
* Be sure to specify which side the motor is to be mounted (ML/MR).

* See page Pre-35 for explanation of each code that makes up the configuration name.

Power-saving



Technical References P. A-5



(1) The load capacity is based on operation at an acceleration of 0.3G (2G for the 2mm-lead model, or when used vertically). These values are the upper limits for the acceleration.

Actuator Specifications

■ Lead and Load Capacity

Model	Motor Output (W)	Lead (mm)	Max. Load Capacity		Rated Thrust (N)	Stroke (mm)
			Horizontal (kg)	Vertical (kg)		
RCA2-SA3R-I-10-6-①-②-③-④	10	6	1	0.5	28	50~300 (50mm increments)
RCA2-SA3R-I-10-4-①-②-③-④		4	2	1	43	
RCA2-SA3R-I-10-2-①-②-③-④		2	3	1.5	85	

Legend ① Stroke ② Compatible controller ③ Cable length ④ Options

■ Stroke and Maximum Speed

Stroke Lead	50 ~ 300 (50mm increments)	
	6	300
4	200	
2	100	

(Unit: mm/s)

① Stroke List

Stroke (mm)	Standard Price	
	With cover (standard)	No cover (Option)
50	-	-
100	-	-
150	-	-
200	-	-
250	-	-
300	-	-

③ Cable List

Type	Cable Symbol	Standard Price
Standard (Robot Cables)	P (1m)	—
	S (3m)	—
	M (5m)	—
Special Lengths	X06 (6m) ~ X10 (10m)	—
	X11 (11m) ~ X15 (15m)	—
	X16 (16m) ~ X20 (20m)	—

* The standard cable is the motor-encoder integrated robot cable.

* See page A-39 for cables for maintenance.

④ Option List

Name	Option Code	See Page	Standard Price
Brake-Equipped	B	→ A-25	—
Cable Exit Direction (Top)	CJT	→ A-25	—
Cable Exit Direction (Outside)	CJO	→ A-25	—
Cable Exit Direction (Bottom)	CJB	→ A-25	—
Power-saving	LA	→ A-32	—
Left-Mounted Motor (Standard)	ML	→ A-33	—
Right-Mounted Motor	MR	→ A-33	—
No Cover	NCO	→ A-33	—
Reversed-home	NM	→ A-33	—

Actuator Specifications

Item	Description
Drive System	Ball screw Ø6mm C10 grade
Positioning Repeatability	±0.02mm
Lost Motion	0.1mm or less
Base	Material: Aluminum (special alumite treated)
Allowable Static Load Moment	Ma: 5.0N-m Mb: 7.1N-m Mc: 7.9N-m
Allowable Dynamic Load Moment	Ma: 1.96N-m Mb: 2.84N-m Mc: 3.14N-m
Overhang Load Length	100mm or less
Ambient Operating Temp./Humidity	0~40°C, 85% RH or less (non-condensing)

Directions of Allowable Load Moments

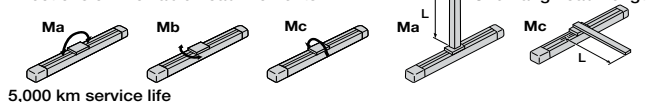

Dimensions

CAD drawings can be downloaded from IAI website. www.intelligentactuator.com



For Special Orders P. A-9

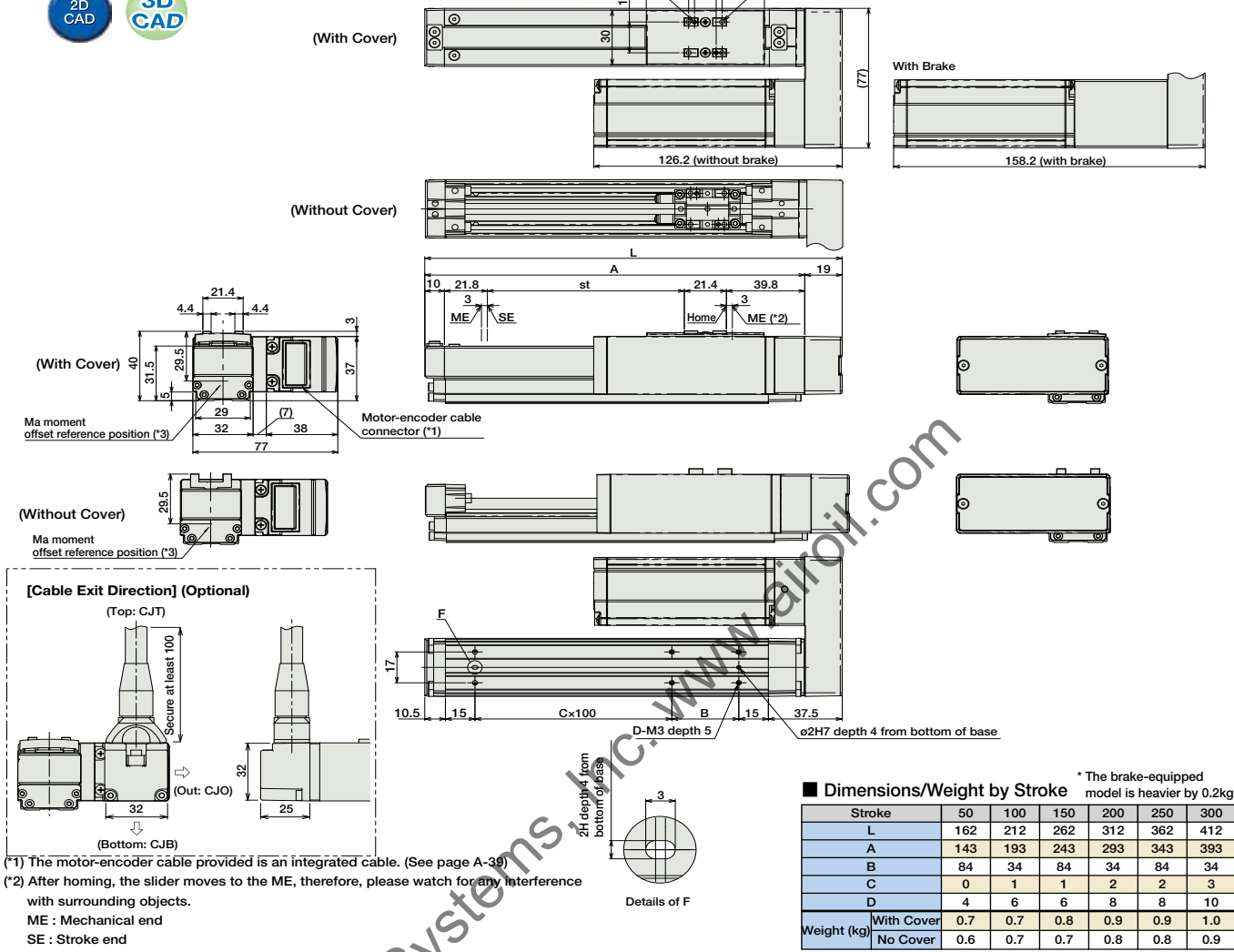

(*1) The motor-encoder cable provided is an integrated cable. (See page A-39)
 (*2) After homing, the slider moves to the ME, therefore, please watch for any interference with surrounding objects.
 ME : Mechanical end
 SE : Stroke end
 (*3) Reference position for calculating the moment Ma

② Compatible Controllers

The RCA2 series actuators can operate with the controllers below. Select the controller according to your usage.

Name	External View	Model	Description	Max. Positioning Points	Input Voltage	Power Supply Capacity	Standard Price	See Page
Solenoid Valve Type		AMEC-C-10①-NP-2-1	Easy-to-use controller, even for beginners	3 points	AC100V	2.4A rated	—	→ P477
		ASEP-C-10①-NP-2-0	Operable with same signal as solenoid valve. Supports both single and double solenoid types. No homing necessary with simple absolute type.					
Splash-Proof Solenoid Valve Type		ASEP-CW-10①-NP-2-0						→ P487
Positioner Type		ACON-C-10①-NP-2-0	Positioning is possible for up to 512 points	512 points	DC24V	(Standard) 1.3A rated 4.4A max.	—	→ P535
Safety-Compliant Positioner Type		ACON-CG-10①-NP-2-0						
Pulse Train Input Type (Differential Line Driver)		ACON-PL-10①-NP-2-0	Pulse train input type with differential line driver support	(-)	DC24V	(Power-saving) 1.3A rated 2.5A max.	—	→ P535
Pulse Train Input Type (Open Collector)		ACON-PO-10①-NP-2-0	Pulse train input type with open collector support					
Serial Communication Type		ACON-SE-10①-N-0-0	Dedicated to serial communication	64 points				
Field Network Type		RACON-10①	Dedicated to field network	768 points				→ P503
Program Control Type		ASEL-C-1-10①-NP-2-0	Programmed operation is possible Can operate up to 2 axes	1500 points				→ P567

* This is for the single-axis ASEL.
 * ① is replaced with the code "LA" when support for power-saving is specified.

- Slider Type
- Mini
- Standard
- Controllers Integrated
- Rod Type
- Mini
- Standard
- Controllers Integrated
- Table/Arm/Flat Type
- Mini
- Standard
- Gripper/Rotary Type
- Linear Servo Type
- Cleanroom Type
- Splash-Proof
- Controllers
- PMEC/AMEC
- PSEP/ASEP
- ROBO NET
- ERC2
- PCON
- ACON
- SCON
- PSEL
- ASEL
- SSEL
- XSEL
- Pulse Motor
- Servo Motor (24V)
- Servo Motor (200V)
- Linear Servo Motor

RCA2-SA4R

ROBO Cylinder Slider Type 40mm Width Servo Motor Side-Mounted Motor

■ Configuration: **RCA2** — **SA4R** — **I** — **20** — — — — —

Series — Type — Encoder — Motor — Lead — Stroke — Compatible Controllers — Cable Length — Option

I: Incremental 20: 20W Servo motor
 * Simple absolute encoder models are labeled as "I".

10: 10mm
 5: 5mm
 2.5: 2.5mm

50: 50mm
 500: 500mm (50mm pitch increments)

A1: ACON
 RACON
 ASEL
 A3: AMEC
 ASEP

N : None
 P : 1m
 S : 3m
 M : 5m
 X : Custom Length

See Options below
 * Be sure to specify which side the motor is to be mounted (ML/MR).

* See page Pre-35 for explanation of each code that makes up the configuration name.

Power-saving



Technical References P. A-5

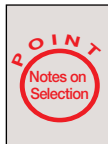

(1) The load capacity is based on operation at an acceleration of 0.3G (0.2G for the 2.5mm-lead model, or when used vertically). These values are the upper limits for the acceleration.

Actuator Specifications

■ Lead and Load Capacity

Model	Motor Output (W)	Lead (mm)	Max. Load Capacity		Rated Thrust (N)	Stroke (mm)
			Horizontal (kg)	Vertical (kg)		
RCA2-SA4R-I-20-10- <input type="checkbox"/> - <input type="checkbox"/> - <input type="checkbox"/> - <input type="checkbox"/>	20	10	2	1	34	50~500 (50mm increments)
RCA2-SA4R-I-20-5- <input type="checkbox"/> - <input type="checkbox"/> - <input type="checkbox"/> - <input type="checkbox"/>		5	4	1.5	68	
RCA2-SA4R-I-20-2.5- <input type="checkbox"/> - <input type="checkbox"/> - <input type="checkbox"/> - <input type="checkbox"/>		2.5	6	3	136	

■ Stroke and Maximum Speed

Stroke Lead	50 ~ 500 (50mm increments)	
	10	500
5	250	
2.5	125	

Legend Stroke Compatible controller Cable length Options

(Unit: mm/s)

① Stroke List

Stroke (mm)	Standard Price	
	With cover (standard)	No cover (Option)
50	-	-
100	-	-
150	-	-
200	-	-
250	-	-
300	-	-
350	-	-
400	-	-
450	-	-
500	-	-

③ Cable List

Type	Cable Symbol	Standard Price
Standard (Robot Cables)	P (1m)	—
	S (3m)	—
	M (5m)	—
Special Lengths	X06 (6m) ~ X10 (10m)	—
	X11 (11m) ~ X15 (15m)	—
	X16 (16m) ~ X20 (20m)	—

* The standard cable is the motor-encoder integrated robot cable.

* See page A-39 for cables for maintenance.

④ Option List

Name	Option Code	See Page	Standard Price
Brake-Equipped	B	→ A-25	—
Cable Exit Direction (Top)	CJT	→ A-25	—
Cable Exit Direction (Outside)	CJO	→ A-25	—
Cable Exit Direction (Bottom)	CJB	→ A-25	—
Power-saving	LA	→ A-32	—
Left-Mounted Motor (Standard)	ML	→ A-33	—
Right-Mounted Motor	MR	→ A-33	—
No Cover	NCO	→ A-33	—
Reversed-home	NM	→ A-33	—

Actuator Specifications

Item	Description
Drive System	Ball screw Ø8mm C10 grade
Positioning Repeatability	±0.02mm
Lost Motion	0.1mm or less
Base	Material: Aluminum (special alumite treated)
Allowable Static Load Moment	Ma: 6.8N·m Mb: 9.7N·m Mc: 13.3N·m
Allowable Dynamic Load Moment	Ma: 3.04N·m Mb: 4.31N·m Mc: 5.00N·m
Overhang Load Length	120mm or less
Ambient Operating Temp./Humidity	0~40°C, 85% RH or less (non-condensing)

Directions of Allowable Load Moments

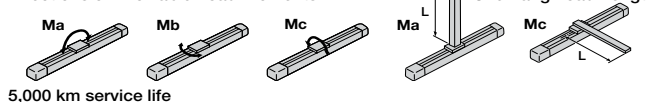

Dimensions

CAD drawings can be downloaded from IAI website. www.intelligentactuator.com



For Special Orders P. A-9

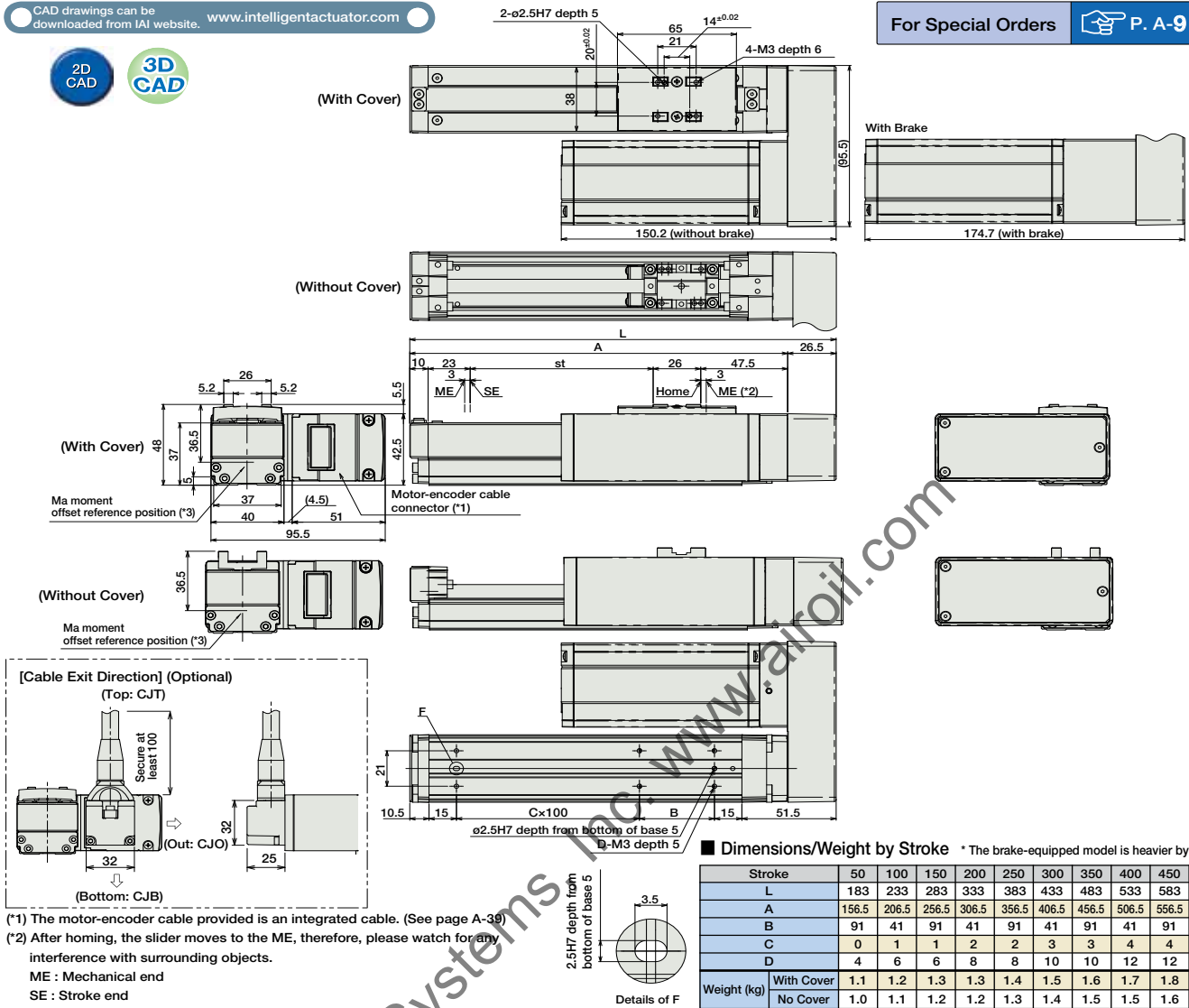

■ Dimensions/Weight by Stroke * The brake-equipped model is heavier by 0.3kg.

Stroke	50	100	150	200	250	300	350	400	450	500
L	183	233	283	333	383	433	483	533	583	633
A	156.5	206.5	256.5	306.5	356.5	406.5	456.5	506.5	556.5	606.5
B	91	41	91	41	91	41	91	41	91	41
C	0	1	1	2	2	3	3	4	4	5
D	4	6	6	8	8	10	10	12	12	14
Weight (kg)	With Cover	1.1	1.2	1.3	1.3	1.4	1.5	1.6	1.7	1.8
	No Cover	1.0	1.1	1.2	1.2	1.3	1.4	1.5	1.5	1.6

(*1) The motor-encoder cable provided is an integrated cable. (See page A-39)

(*2) After homing, the slider moves to the ME, therefore, please watch for any interference with surrounding objects.

ME : Mechanical end
SE : Stroke end

(*3) Reference position for calculating the moment Ma

② Compatible Controllers

The RCA2 series actuators can operate with the controllers below. Select the controller according to your usage.

Name	External View	Model	Description	Max. Positioning Points	Input Voltage	Power Supply Capacity	Standard Price	See Page
Solenoid Valve Type		AMEC-C-20Si①-NP-2-1	Easy-to-use controller, even for beginners	3 points	AC100V	2.4A rated	—	→ P477
		ASEP-C-20Si①-NP-2-0	Operable with same signal as solenoid valve. Supports both single and double solenoid types. No homing necessary with simple absolute type.					
Splash-Proof Solenoid Valve Type		ASEP-CW-20Si①-NP-2-0						→ P487
Positioner Type		ACON-C-20Si①-NP-2-0	Positioning is possible for up to 512 points	512 points	DC24V	(Standard) 1.7A rated 5.1A max.	—	→ P535
Safety-Compliant Positioner Type		ACON-CG-20Si①-NP-2-0						
Pulse Train Input Type (Differential Line Driver)		ACON-PL-20Si①-NP-2-0	Pulse train input type with differential line driver support	(-)		(Power-saving) 1.7A rated 3.4A max.	—	
Pulse Train Input Type (Open Collector)		ACON-PO-20Si①-NP-2-0	Pulse train input type with open collector support					
Serial Communication Type		ACON-SE-20Si①-N-0-0	Dedicated to serial communication	64 points			—	
Field Network Type		RACON-20S①	Dedicated to field network	768 points			—	→ P503
Program Control Type		ASEL-C-1-20Si①-NP-2-0	Programmed operation is possible Can operate up to 2 axes	1500 points			—	→ P567

* This is for the single-axis ASEL.

* ① is replaced with the code "LA" when support for power-saving is specified.

- Slider Type
- Mini
- Standard
- Controllers Integrated
- Rod Type
- Mini
- Standard
- Controllers Integrated
- Table/Arm/Flat Type
- Mini
- Standard
- Gripper/Rotary Type
- Linear Servo Type
- Cleanroom Type
- Splash-Proof
- Controllers
- PMEC /AMEC
- PSEP /ASEP
- ROBO NET
- ERC2
- PCON
- ACON
- SCON
- PSEL
- ASEL
- SSEL
- XSEL
- Pulse Motor
- Servo Motor (24V)
- Servo Motor (200V)
- Linear Servo Motor

RCA2-SA5R

ROBO Cylinder Slider Type 50mm Width Servo Motor Side-Mounted Motor

■ Configuration: **RCA2** — **SA5R** — **I** — **20** — — — — —

Series — Type — Encoder — Motor — Lead — Stroke — Compatible Controllers — Cable Length — Option

I: Incremental 20: 20W Servo motor
 * Simple absolute encoder models are labeled as "I".

12: 12mm
 6: 6mm
 3: 3mm

50: 50mm
 800: 800mm (50mm pitch increments)

A1: ACON
 RACON
 ASEL
 A3: AMEC
 ASEP

N: None
 P: 1m
 S: 3m
 M: 5m
 X : Custom Length

See Options below
 * Be sure to specify which side the motor is to be mounted (ML/MR).

* See page Pre-35 for explanation of each code that makes up the configuration name.

Power-saving



Technical References P. A-5

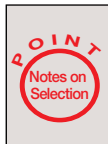

(1) The load capacity is based on operation at an acceleration of 0.3G (0.2G for the 3mm-lead model, or when used vertically). These values are the upper limits for the acceleration.

Actuator Specifications

■ Lead and Load Capacity

Model	Motor Output (W)	Lead (mm)	Max. Load Capacity		Rated Thrust (N)	Stroke (mm)
			Horizontal (kg)	Vertical (kg)		
RCA2-SA5R-I-20-12-①-②-③-④	20	12	3	1	17	50~800 (50mm increments)
RCA2-SA5R-I-20-6-①-②-③-④		6	6	1.5	34	
RCA2-SA5R-I-20-3-①-②-③-④		3	9	3	68	

■ Stroke and Maximum Speed

Stroke / Lead	50 ~ 550 (50mm increments)	600 (mm)	650 (mm)	700 (mm)	750 (mm)	800 (mm)
12	600	570	490	425	370	330
6	300	285	245	210	185	165
3	150	140	120	105	90	80

(Unit: mm/s)

Legend ① Stroke ② Compatible controller ③ Cable length ④ Options

① Stroke List

Stroke (mm)	Standard Price	
	With cover (standard)	No cover (Option)
50	-	-
100	-	-
150	-	-
200	-	-
250	-	-
300	-	-
350	-	-
400	-	-
450	-	-
500	-	-
550	-	-
600	-	-
650	-	-
700	-	-
750	-	-
800	-	-

③ Cable List

Type	Cable Symbol	Standard Price
Standard (Robot Cables)	P (1m)	—
	S (3m)	—
	M (5m)	—
Special Lengths	X06 (6m) ~ X10 (10m)	—
	X11 (11m) ~ X15 (15m)	—
	X16 (16m) ~ X20 (20m)	—

* The standard cable is the motor-encoder integrated robot cable.
 * See page A-39 for cables for maintenance.

④ Option List

Name	Option Code	See Page	Standard Price
Brake-Equipped	B	→ A-25	—
Cable Exit Direction (Top)	CJT	→ A-25	—
Cable Exit Direction (Outside)	CJO	→ A-25	—
Cable Exit Direction (Bottom)	CJB	→ A-25	—
Power-saving	LA	→ A-32	—
Left-Mounted Motor (Standard)	ML	→ A-33	—
Right-Mounted Motor	MR	→ A-33	—
No Cover	NCO	→ A-33	—
Reversed-home	NM	→ A-33	—

Actuator Specifications

Item	Description
Drive System	Ball screw Ø10mm C10 grade
Positioning Repeatability	±0.02mm
Lost Motion	0.1mm or less
Base	Material: Aluminum (special alumite treated)
Allowable Static Load Moment	Ma: 10.2N·m Mb: 14.6N·m Mc: 8.53N·m
Allowable Dynamic Load Moment	Ma: 3.92N·m Mb: 5.58N·m Mc: 8.53N·m
Overhang Load Length	130mm or less
Ambient Operating Temp./Humidity	0~40°C, 85% RH or less (non-condensing)

Directions of Allowable Load Moments

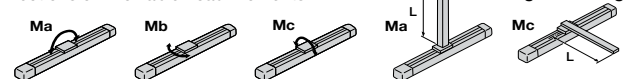

5,000 km service life

Dimensions

CAD drawings can be downloaded from IAI website. www.intelligentactuator.com



For Special Orders P. A-9

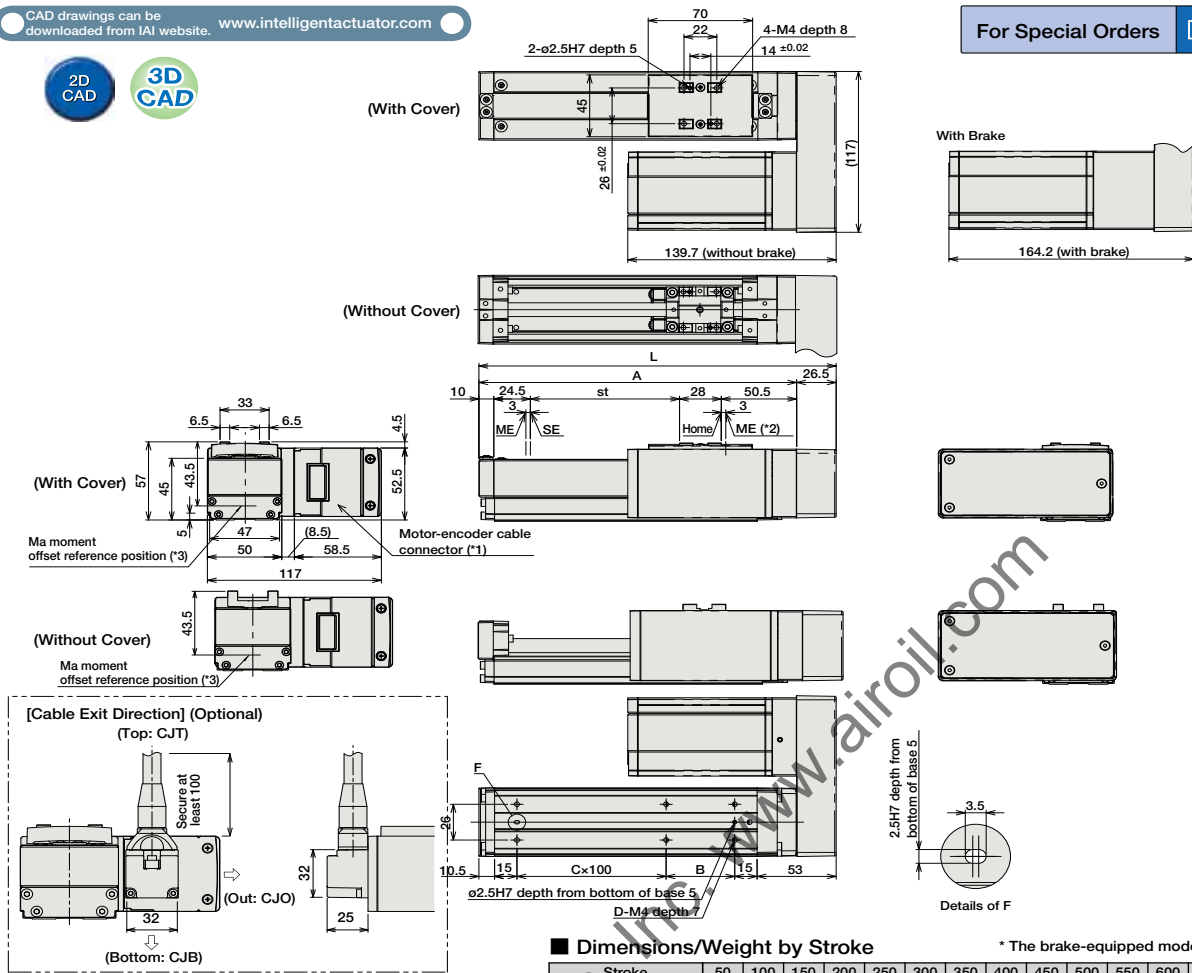

Dimensions/Weight by Stroke

* The brake-equipped model is heavier by 0.4kg.

Stroke	50	100	150	200	250	300	350	400	450	500	550	600	650	700	750	800
L	189.5	239.5	289.5	339.5	389.5	439.5	489.5	539.5	589.5	639.5	689.5	739.5	789.5	839.5	889.5	939.5
A	163	213	263	313	363	413	463	513	563	613	663	713	763	813	863	913
B	96	46	96	46	96	46	96	46	96	46	96	46	96	46	96	46
C	0	1	1	2	2	3	3	4	4	5	5	6	6	7	7	8
D	4	6	6	8	8	10	10	12	12	14	14	16	16	18	18	20
Weight (kg)	With Cover	1.5	1.7	1.8	1.9	2.1	2.2	2.3	2.5	2.6	2.7	2.9	3.0	3.1	3.3	3.4
	No Cover	1.4	1.6	1.7	1.8	1.9	2.0	2.1	2.2	2.3	2.4	2.5	2.6	2.7	2.8	2.9

- (*1) The motor-encoder cable provided is an integrated cable. (See page A-39.)
- (*2) After homing, the slider moves to the ME, therefore, please watch for any interference with surrounding objects.
ME : Mechanical end
SE : Stroke end
- (*3) Reference position for calculating the moment Ma

Compatible Controllers

The RCA2 series actuators can operate with the controllers below. Select the controller according to your usage.

Name	External View	Model	Description	Max. Positioning Points	Input Voltage	Power Supply Capacity	Standard Price	See Page
Solenoid Valve Type		AMEC-C-20①-NP-2-1	Easy-to-use controller, even for beginners	3 points	AC100V	2.4A rated	—	→ P477
		ASEP-C-20①-NP-2-0	Operable with same signal as solenoid valve. Supports both single and double solenoid types. No homing necessary with simple absolute type.					
Splash-Proof Solenoid Valve Type		ASEP-CW-20①-NP-2-0					—	→ P487
Positioner Type		ACON-C-20①-NP-2-0	Positioning is possible for up to 512 points	512 points	DC24V	(Standard) 1.3A rated 4.4A max.	—	→ P535
Safety-Compliant Positioner Type		ACON-CG-20①-NP-2-0						
Pulse Train Input Type (Differential Line Driver)		ACON-PL-20①-NP-2-0	Pulse train input type with differential line driver support	(-)	DC24V	(Power-saving) 1.3A rated 2.5A max.	—	→ P535
Pulse Train Input Type (Open Collector)		ACON-PO-20①-NP-2-0	Pulse train input type with open collector support					
Serial Communication Type		ACON-SE-20①-N-0-0	Dedicated to serial communication	64 points			—	
Field Network Type		RACON-20①	Dedicated to field network	768 points			—	→ P503
Program Control Type		ASEL-C-1-20①-NP-2-0	Programmed operation is possible. Can operate up to 2 axes	1500 points			—	→ P567

* This is for the single-axis ASEL.
* ① is replaced with the code "LA" when support for power-saving is specified.

RCA2-SA6R

ROBO Cylinder Slider Type 60mm Width Servo Motor Side-Mounted Motor

■ Configuration: **RCA2** — **SA6R** — **I** — **30** — — — — —

Series — Type — Encoder — Motor — Lead — Stroke — Compatible Controllers — Cable Length — Option

I: Incremental
* Simple absolute encoder models are labeled as "I".

30: 30W Servo motor

12: 12mm
6: 6mm
3: 3mm

50: 50mm
800: 800mm (50mm pitch increments)

A1: ACON
RACON
ASEL
A3: AMEC
ASEP

N: None
P: 1m
S: 3m
M: 5m
X : Custom Length

See Options below
* Be sure to specify which side the motor is to be mounted (ML/MR).

* See page Pre-35 for explanation of each code that makes up the configuration name.

Power-saving



Technical References P. A-5

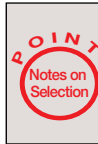

- (1) When the stroke increases, the maximum speed will drop to prevent the ball screw from reaching the critical rotational speed. Use the actuator specification table below to check the maximum speed at the stroke you desire.
- (2) The load capacity is based on operation at an acceleration of 0.3G (0.2G for the 3mm-lead model). These values are the upper limits for the acceleration.

Actuator Specifications

■ Lead and Load Capacity

Model	Motor Output (W)	Lead (mm)	Max. Load Capacity Horizontal (kg) Vertical (kg)	Rated Thrust (N)	Stroke (mm)
RCA2-SA6R-I-30-12-①-②-③-④	30	12	4 1.5	26	50~800 (50mm increments)
RCA2-SA6R-I-30-6-①-②-③-④		6	7 2	53	
RCA2-SA6R-I-30-3-①-②-③-④		3	10 4	105	

■ Stroke and Maximum Speed

Stroke/Lead	50 ~ 550 (50mm increments)	600 (mm)	650 (mm)	700 (mm)	750 (mm)	800 (mm)
12	600	570	490	425	370	330
6	300	285	245	210	185	165
3	150	140	120	105	90	80

Legend ① Stroke ② Compatible controller ③ Cable length ④ Options (Unit: mm/s)

① Stroke List

Stroke (mm)	Standard Price	
	With cover (standard)	No cover (Option)
50	-	-
100	-	-
150	-	-
200	-	-
250	-	-
300	-	-
350	-	-
400	-	-
450	-	-
500	-	-
550	-	-
600	-	-
650	-	-
700	-	-
750	-	-
800	-	-

③ Cable List

Type	Cable Symbol	Standard Price
Standard (Robot Cables)	P (1m)	—
	S (3m)	—
	M (5m)	—
Special Lengths	X06 (6m) ~ X10 (10m)	—
	X11 (11m) ~ X15 (15m)	—
	X16 (16m) ~ X20 (20m)	—

* The standard cable is the motor-encoder integrated robot cable.
* See page A-39 for cables for maintenance.

④ Option List

Name	Option Code	See Page	Standard Price
Brake-Equipped	B	→ A-25	—
Cable Exit Direction (Top)	CJT	→ A-25	—
Cable Exit Direction (Outside)	CJO	→ A-25	—
Cable Exit Direction (Bottom)	CJB	→ A-25	—
Power-saving	LA	→ A-32	—
Left-Mounted Motor (Standard)	ML	→ A-33	—
Right-Mounted Motor	MR	→ A-33	—
No Cover	NCO	→ A-33	—
Reversed-home	NM	→ A-33	—

Actuator Specifications

Item	Description
Drive System	Ball screw Ø10mm C10 grade
Positioning Repeatability	±0.02mm
Lost Motion	0.1mm or less
Base	Aluminum (special alumite treated)
Allowable Static Load Moment	Ma: 17.6N·m Mb: 25.2N·m Mc: 44.5N·m
Allowable Dynamic Load Moment	Ma: 4.31N·m Mb: 6.17N·m Mc: 10.98N·m
Overhang Load Length	150mm or less
Ambient Operating Temp./Humidity	0~40°C, 85% RH or less (non-condensing)

Directions of Allowable Load Moments

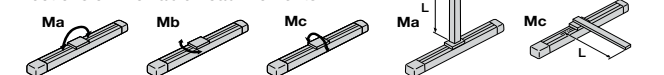

5,000 km service life

Dimensions

CAD drawings can be downloaded from IAI website. www.intelligentactuator.com



For Special Orders P. A-9

- (*1) The motor-encoder cable provided is an integrated cable. (See page A-39)
- (*2) After homing, the slider moves to the ME, therefore, please watch for any interference with surrounding objects.
- ME : Mechanical end
- SE : Stroke end
- (*3) Reference position for calculating the moment Ma

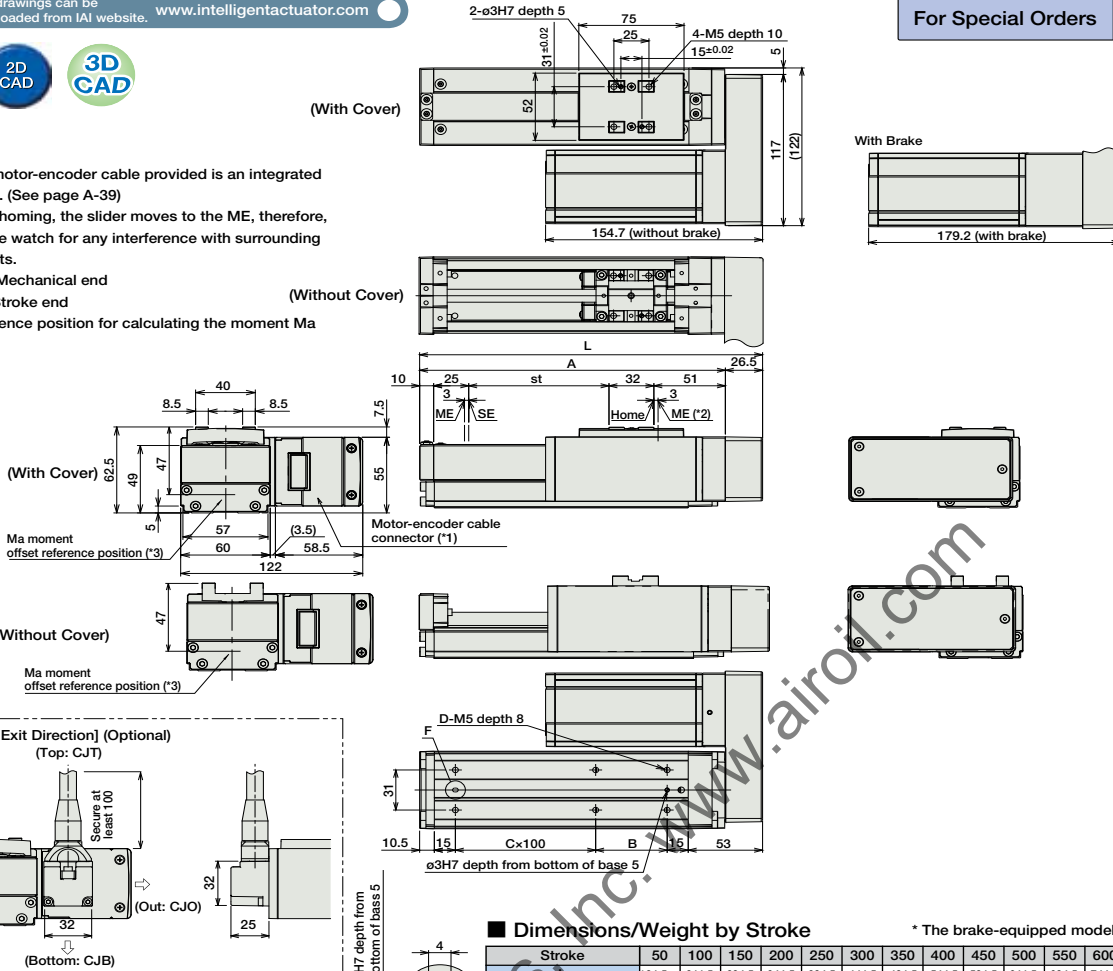

■ Dimensions/Weight by Stroke

* The brake-equipped model is heavier by 0.4kg.

Stroke	50	100	150	200	250	300	350	400	450	500	550	600	650	700	750	800	
L	194.5	244.5	294.5	344.5	394.5	444.5	494.5	544.5	594.5	644.5	694.5	744.5	794.5	844.5	894.5	944.5	
A	168	218	268	318	368	418	468	518	568	618	668	718	768	818	868	918	
B	101	51	101	51	101	51	101	51	101	51	101	51	101	51	101	51	
C	0	1	1	2	2	3	3	4	4	5	5	6	6	7	7	8	
D	4	6	6	8	8	10	10	12	12	14	14	16	16	18	18	20	
Weight (kg)	With Cover	1.9	2.0	2.2	2.4	2.6	2.7	2.9	3.1	3.2	3.4	3.6	3.8	3.9	4.1	4.3	4.5
	No Cover	1.8	1.9	2.1	2.2	2.4	2.5	2.6	2.8	2.9	3.1	3.2	3.4	3.5	3.7	3.8	3.9

② Compatible Controllers

The RCA2 series actuators can operate with the controllers below. Select the controller according to your usage.

Name	External View	Model	Description	Max. Positioning Points	Input Voltage	Power Supply Capacity	Standard Price	See Page
Solenoid Valve Type		AMEC-C-30①-NP-2-1	Easy-to-use controller, even for beginners	3 points	AC100V	2.4A rated	—	→ P477
		ASEP-C-30①-NP-2-0	Operable with same signal as solenoid valve. Supports both single and double solenoid types. No homing necessary with simple absolute type.					
Splash-Proof Solenoid Valve Type		ASEP-CW-30①-NP-2-0						→ P487
Positioner Type		ACON-C-30①-NP-2-0	Positioning is possible for up to 512 points	512 points	DC24V	(Standard) 1.3A rated 4.0A max.	—	→ P535
Safety-Compliant Positioner Type		ACON-CG-30①-NP-2-0						
Pulse Train Input Type (Differential Line Driver)		ACON-PL-30①-NP-2-0	Pulse train input type with differential line driver support	(-)	DC24V	(Power-saving) 1.3A rated 2.2A max.	—	→ P535
Pulse Train Input Type (Open Collector)		ACON-PO-30①-NP-2-0	Pulse train input type with open collector support					
Serial Communication Type		ACON-SE-30①-N-0-0	Dedicated to serial communication	64 points			—	
Field Network Type		RACON-30①	Dedicated to field network	768 points			—	→ P503
Program Control Type		ASEL-C-1-30①-NP-2-0	Programmed operation is possible Can operate up to 2 axes	1500 points			—	→ P567

* This is for the single-axis ASEL.

* ① is replaced with the code "LA" when support for power-saving is specified.

RCA-SA4C

ROBO Cylinder Slider Type 40mm Width 24V Servo Motor Coupled

■ Configuration: **RCA** — **SA4C** — — **20** — — — — —

Series — Type — Encoder — Motor — Lead — Stroke — Compatible Controllers — Cable Length — Option

I: Incremental
A: Absolute
20: 20W Servo motor
10: 10mm
5: 5mm
2.5: 2.5mm
50: 50mm
400: 400mm (50mm pitch increments)
A1: ACON
RACON
ASEL
A3: AMEC
ASEP
N: None
P: 1m
S: 3m
M: 5m
X : Custom Length
R : Robot Cable

* See page Pre-35 for explanation of each code that makes up the configuration name.
* Absolute encoder models can only use ASEL.
When the actuator is used with the simple absolute encoder, the model is considered an incremental model.

See Options below

For High Acceleration/Deceleration **Power-saving**
(excluding the 2.5-mm lead model)

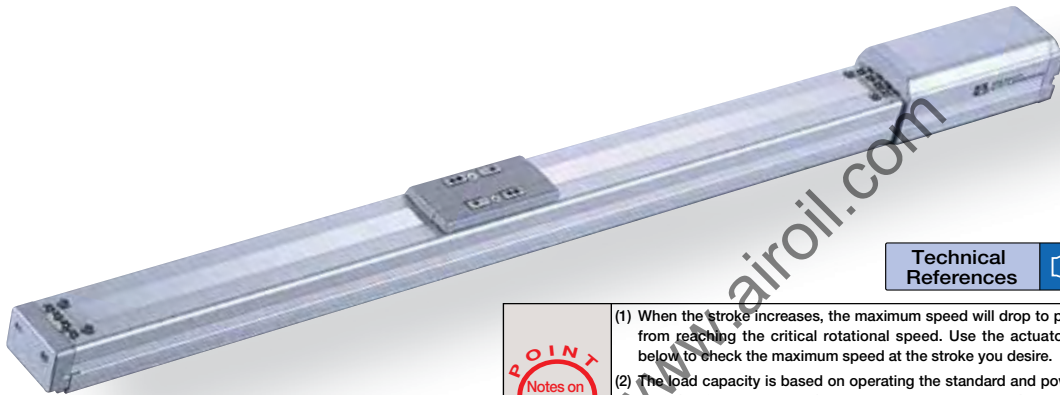

Technical References P. A-5

- POINT**
Notes on Selection
- When the stroke increases, the maximum speed will drop to prevent the ball screw from reaching the critical rotational speed. Use the actuator specification table below to check the maximum speed at the stroke you desire.
 - The load capacity is based on operating the standard and power-saving models at 0.3G (0.2G for 3mm-lead), and the high acceleration/deceleration model at 1G (excluding the 2.5mm-lead model). (Even when the acceleration/deceleration is dropped, the maximum load capacity values shown in the table below are the upper limits.)

Actuator Specifications						Stroke and Maximum Speed	
■ Lead and Load Capacity						50 ~ 400 (50mm increments)	
Model	Motor Output (W)	Lead (mm)	Max. Load Capacity Horizontal (kg)	Max. Load Capacity Vertical (kg)	Rated Thrust (N)	Stroke (mm)	Lead
RCA-SA4C-①-20-10-②-③-④-⑤	20	10	4	1	19.6	50 ~ 400 (50mm increments)	10
RCA-SA4C-①-20-5-②-③-④-⑤		5	6	2.5	39.2		5
RCA-SA4C-①-20-2.5-②-③-④-⑤		2.5	8	4.5	78.4		2.5

Legend ① Encoder ② Stroke ③ Compatible controller ④ Cable length ⑤ Option (Unit: mm/s)

Encoder & Stroke List		
② Stroke (mm)	Standard Price	
	① Encoder Type	
	Incremental	Absolute
	I	A
50	-	-
100	-	-
150	-	-
200	-	-
250	-	-
300	-	-
350	-	-
400	-	-

④ Cable List		
Type	Cable Symbol	Standard Price
Standard	P (1m)	—
	S (3m)	—
	M (5m)	—
Special Lengths	X06 (6m) ~ X10 (10m)	—
	X11 (11m) ~ X15 (15m)	—
	X16 (16m) ~ X20 (20m)	—
	R01 (1m) ~ R03 (3m)	—
Robot Cable	R04 (4m) ~ R05 (5m)	—
	R06 (6m) ~ R10 (10m)	—
	R11 (11m) ~ R15 (15m)	—
	R16 (16m) ~ R20 (20m)	—

* See page A-39 for cables for maintenance.

⑤ Option List			
Name	Option Code	See Page	Standard Price
Brake	B	→ A-25	—
Foot bracket	FT	→ A-29	—
For High Acceleration/Deceleration	HA	→ A-32	—
Home sensor	HS	→ A-32	—
Power-saving	LA	→ A-32	—
Reversed-home	NM	→ A-33	—
Slider Roller	SR	→ A-36	—
Slider spacer	SS	→ A-36	—

Actuator Specifications	
Item	Description
Drive System	Ball screw Ø8mm C10 grade
Positioning Repeatability	±0.02mm
Lost Motion	0.1mm or less
Base	Material: Aluminum (white alumite treated)
Allowable Static Moment	Ma: 6.9N·m Mb: 9.9N·m Mc: 17.0N·m
Allowable Dynamic Moment (*)	Ma: 2.7N·m Mb: 3.9N·m Mc: 6.8N·m
Overhang Load Length	Ma direction: 120mm or less Mb-Mc direction: 120mm or less
Ambient Operating Temp./Humidity	0~40°C, 85% RH or less (non-condensing)

(*) Based on 5,000km travel life.
Directions of Allowable Load Moments

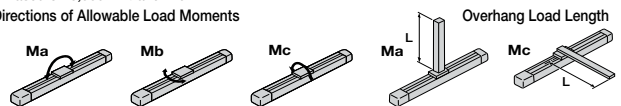

* The high-acceleration/deceleration option and the Slider Roller option cannot be used together.
* The 2.5mm-lead model cannot be used with the high-acceleration/deceleration option.
* The high-acceleration/deceleration option and the power saving option cannot be used together.

Dimensions

CAD drawings can be downloaded from IAI website. www.intelligentactuator.com

For Special Orders P. A-9



- * 1 A motor-encoder cable is connected here. See page A-39 for details on cables.
- * 2 When homing, the slider moves to the ME; therefore, please watch for any interference with the surrounding objects.
ME: Mechanical end
SE: Stroke end
- * 3 Reference position for calculating the moment Ma.
- * 4 If the actuator is secured using only the mounting holes provided on the top surface of the base, the base may twist to cause abnormal sliding of the slider, or may produce abnormal noise. Therefore, when using the mounting holes on the top surface of the base, keep the stroke at 200mm or less.

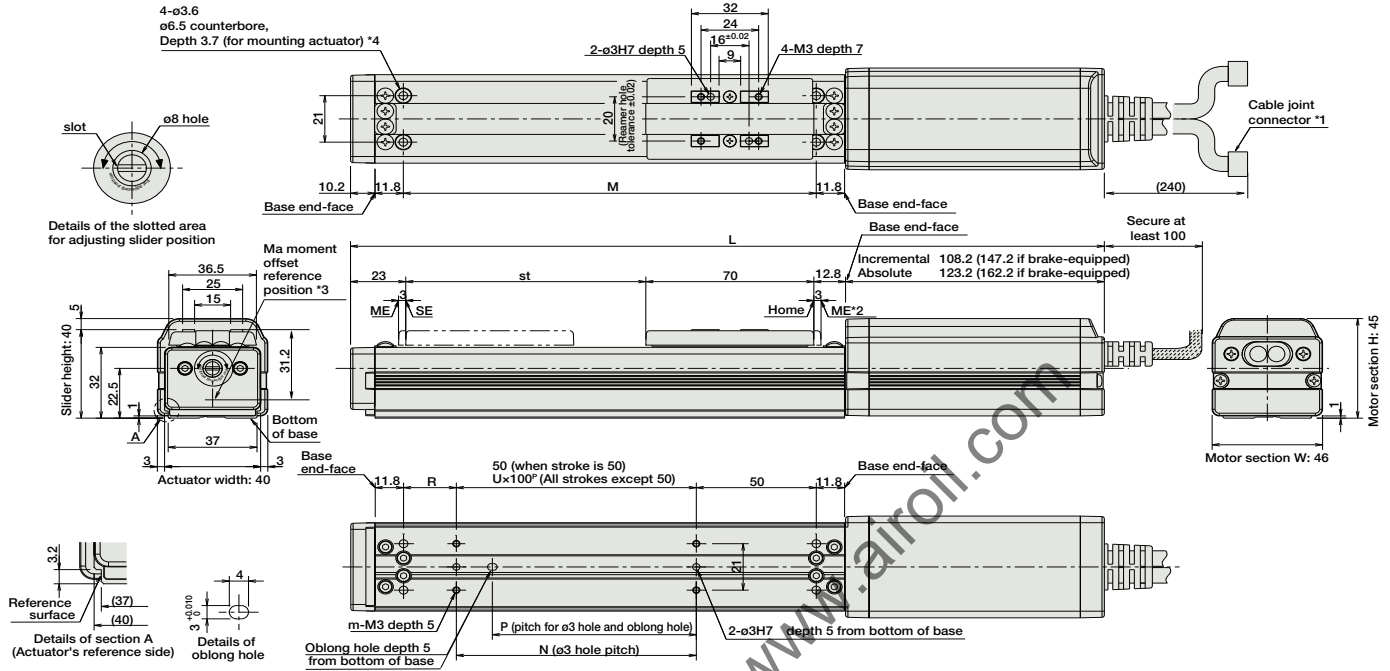

■ Dimensions/Weight by Stroke * Brake-equipped models are heavier by 0.3kg.

L	Stroke	Stroke							
		50	100	150	200	250	300	350	400
Incremental	No Brake	264	314	364	414	464	514	564	614
	With Brake	303	353	403	453	503	553	603	653
Absolute	No Brake	279	329	379	429	479	529	579	629
	With Brake	318	368	418	468	518	568	618	668
M		122	172	222	272	322	372	422	472
N		50	100	100	200	200	300	300	400
P		35	85	85	185	185	285	285	385
R		22	22	72	22	72	22	72	22
U		-	1	1	2	2	3	3	4
m		4	4	4	6	6	8	8	10
Weight (kg)		0.7	0.8	0.9	1	1.1	1.2	1.3	1.4

③ Compatible Controllers

The RCA series actuators can operate with the controllers below. Select the controller according to your usage.

Name	External View	Model	Description	Max. Positioning Points	Input Voltage	Power Supply Capacity	Standard Price	See Page				
Solenoid Valve Type		AMEC-C-20①②-NP-2-1	Easy-to-use controller, even for beginners	3 points	DC24V	2.4A rated (Standard) 1.3A rated 4.4A max. (Power-saving) 1.3A rated 2.5A max.	-	→ P477				
		ASEP-C-20①②-NP-2-0	Operable with same signal as solenoid valve. Supports both single and double solenoid types. No homing necessary with simple absolute type.									
Splash-Proof Solenoid Valve Type		ASEP-CW-20①②-NP-2-0										
Positioner Type		ACON-C-20①②-NP-2-0	Positioning is possible for up to 512 points	512 points								
Safety-Compliant Positioner Type		ACON-CG-20①②-NP-2-0										
Pulse Train Input Type (Differential Line Driver)		ACON-PL-20①②-NP-2-0	Pulse train input type with differential line driver support	(-)								→ P535
Pulse Train Input Type (Open Collector)		ACON-PO-20①②-NP-2-0	Pulse train input type with open collector support									
Serial Communication Type		ACON-SE-20①②-N-0-0	Dedicated to serial communication	64 points								
Field Network Type		RACON-20②	Dedicated to field network	768 points								→ P503
Program Control Type		ASEL-C-1-20①②-NP-2-0	Programmed operation is possible Can operate up to 2 axes	1500 points				→ P567				

* This is for the single-axis ASEL.
 * ① is a placeholder for the encoder type (I: incremental, A: absolute).
 * ② is a placeholder for the code "HA" or "LA", when the high-acceleration/deceleration option or the energy-saving option is selected.

RCA-SA5C ROBO Cylinder Slider Type 52mm Width 24V Servo Motor Coupled

■ Configuration: **RCA** — **SA5C** — [] — **20** — [] — [] — [] — [] — []

Series — Type — Encoder — Motor — Lead — Stroke — Compatible Controllers — Cable Length — Option

I: Incremental 20: 20W Servo motor 12: 12mm 50: 50mm A1: ACON N: None
A: Absolute motor 6: 6mm 500: 500mm RACON P: 1m
* Absolute encoder models can only use ASEL. 3: 3mm (50mm pitch ASEL S: 3m
When the actuator is used with the simple absolute encoder, the model is considered an incremental model. increments) A3: AMEC M: 5m
X []: Custom Length
R []: Robot Cable

See Options below

* See page Pre-35 for explanation of each code that makes up the configuration name.

For High Acceleration/Deceleration

Power-saving

(excluding the 3-mm lead model)

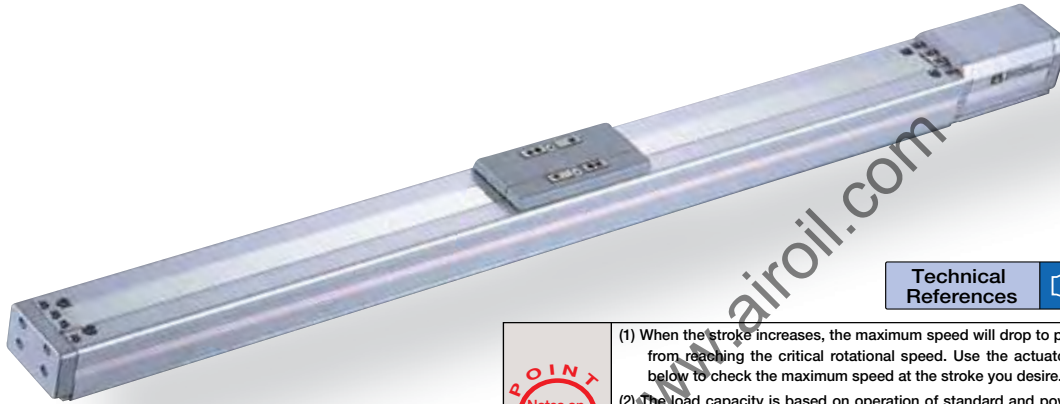

Technical References P. A-5

- POINT**
Notes on Selection
- (1) When the stroke increases, the maximum speed will drop to prevent the ball screw from reaching the critical rotational speed. Use the actuator specification table below to check the maximum speed at the stroke you desire.
 - (2) The load capacity is based on operation of standard and power-saving models at 0.3G (0.2G for 3mm-lead), and operation of the high acceleration/deceleration model at 0.8G (excluding the 3mm-lead model).
(Even when the acceleration/deceleration is dropped, the maximum load capacity values shown in the table below are the upper limits.)

Actuator Specifications

■ Lead and Load Capacity

Model	Motor Output (W)	Lead (mm)	Max. Load Capacity		Rated Thrust (N)	Stroke (mm)
			Horizontal (kg)	Vertical (kg)		
RCA-SA5C-①-20-12-②-③-④-⑤	20	12	4	1	16.7	50 ~ 500 (50mm increments)
RCA-SA5C-①-20-6-②-③-④-⑤		6	8	2	33.3	
RCA-SA5C-①-20-3-②-③-④-⑤		3	12	4	65.7	

■ Stroke and Maximum Speed

Stroke Lead	50 ~ 450 (50mm increments)	500 (mm)
	12	800
6	400	380
3	200	190

Legend ① Encoder ② Stroke ③ Compatible controller ④ Cable length ⑤ Option (Unit: mm/s)

Encoder & Stroke List

② Stroke (mm)	Standard Price	
	① Encoder Type	
	Incremental	Absolute
50	I	A
100	-	-
150	-	-
200	-	-
250	-	-
300	-	-
350	-	-
400	-	-
450	-	-
500	-	-

④ Cable List

Type	Cable Symbol	Standard Price
Standard	P (1m)	—
	S (3m)	—
	M (5m)	—
Special Lengths	X06 (6m) ~ X10 (10m)	—
	X11 (11m) ~ X15 (15m)	—
	X16 (16m) ~ X20 (20m)	—
	R01 (1m) ~ R03 (3m)	—
Robot Cable	R04 (4m) ~ R05 (5m)	—
	R06 (6m) ~ R10 (10m)	—
	R11 (11m) ~ R15 (15m)	—
	R16 (16m) ~ R20 (20m)	—

* See page A-39 for cables for maintenance.

⑤ Option List

Name	Option Code	See Page	Standard Price
Brake	B	→ A-25	—
Foot bracket	FT	→ A-29	—
For High Acceleration/Deceleration	HA	→ A-32	—
Home sensor	HS	→ A-32	—
Power-saving	LA	→ A-32	—
Reversed-home	NM	→ A-33	—
Slider Roller	SR	→ A-36	—

- * The high-acceleration/deceleration option and the slider roller option cannot be used together.
- * The high acceleration/deceleration option cannot be used on the 3mm-lead model.
- * The high-acceleration/deceleration option and the power saving option cannot be used together.

Actuator Specifications

Item	Description
Drive System	Ball screw Ø10mm C10 grade
Positioning Repeatability	±0.02mm
Lost Motion	0.1mm or less
Base	Material: Aluminum (white alumite treated)
Allowable Static Moment	Ma: 18.6N·m Mb: 26.6N·m Mc: 47.5N·m
Allowable Dynamic Moment (*)	Ma: 4.9 N·m Mb: 6.8 N·m Mc: 11.7 N·m
Overhang Load Length	Ma direction: 150mm or less Mb-Mc direction: 150mm or less
Ambient Operating Temp./Humidity	0~40°C, 85% RH or less (non-condensing)

(*) Based on 5,000km travel life.

Directions of Allowable Load Moments

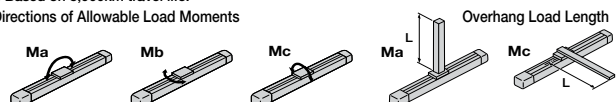

Dimensions

CAD drawings can be downloaded from IAI website. www.intelligentactuator.com

For Special Orders P. A-9



- * 1 A motor-encoder cable is connected here. See page A-39 for details on cables.
- * 2 When homing, the slider moves to the ME; therefore, please watch for any interference with the surrounding objects.

- * 3 Reference position for calculating the moment M_a .
- * 4 If the actuator is secured using only the mounting holes provided on the top surface of the base, the base may twist to cause abnormal sliding of the slider, or may produce abnormal noise. Therefore, when using the mounting holes on the top surface of the base, keep the stroke at 300mm or less.

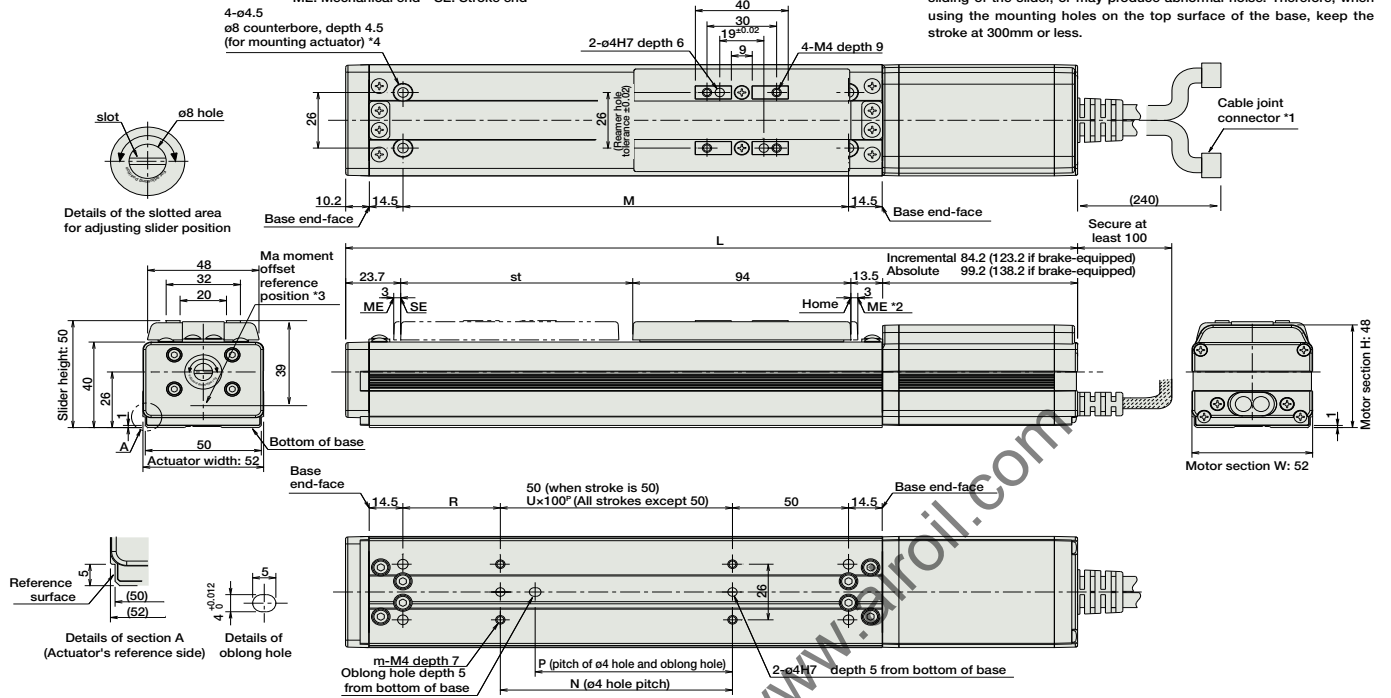

■ Dimensions/Weight by Stroke * Brake-equipped models are heavier by 0.3kg.

Stroke	Stroke										
	50	100	150	200	250	300	350	400	450	500	
Incremental	No Brake	265.4	315.4	365.4	415.4	465.4	515.4	565.4	615.4	665.4	715.4
	With Brake	304.4	354.4	404.4	454.4	504.4	554.4	604.4	654.4	704.4	754.4
Absolute	No Brake	280.4	330.4	380.4	430.4	480.4	530.4	580.4	630.4	680.4	730.4
	With Brake	319.4	369.4	419.4	469.4	519.4	569.4	619.4	669.4	719.4	769.4
M	142	192	242	292	342	392	442	492	542	592	
N	50	100	100	200	200	300	300	400	400	500	
P	35	85	85	185	185	285	285	385	385	485	
R	42	42	92	42	92	42	92	42	92	42	
U	-	1	1	2	2	3	3	4	4	5	
m	4	4	4	6	6	8	8	10	10	12	
Weight (kg)	1.3	1.4	1.5	1.6	1.7	1.8	1.9	2	2.1	2.2	

③ Compatible Controllers

The RCA series actuators can operate with the controllers below. Select the controller according to your usage.

Name	External View	Model	Description	Max. Positioning Points	Input Voltage	Power Supply Capacity	Standard Price	See Page
Solenoid Valve Type		AMEC-C-20②-NP-2-1	Easy-to-use controller, even for beginners	3 points	AC100V	2.4A rated	-	→ P477
		ASEP-C-20②-NP-2-0	Operable with same signal as solenoid valve. Supports both single and double solenoid types. No homing necessary with simple absolute type.					
Splash-Proof Solenoid Valve Type		ASEP-CW-20②-NP-2-0						→ P487
Positioner Type		ACON-C-20②-NP-2-0	Positioning is possible for up to 512 points	512 points	DC24V	(Standard) 1.3A rated 4.4A max.	-	→ P535
Safety-Compliant Positioner Type		ACON-CG-20②-NP-2-0						
Pulse Train Input Type (Differential Line Driver)		ACON-PL-20②-NP-2-0	Pulse train input type with differential line driver support	(-)	DC24V	(Power-saving) 1.3A rated 2.5A max.	-	→ P535
Pulse Train Input Type (Open Collector)		ACON-PO-20②-NP-2-0	Pulse train input type with open collector support					
Serial Communication Type		ACON-SE-20②-N-0-0	Dedicated to serial communication	64 points				
Field Network Type		RACON-20②	Dedicated to field network	768 points				→ P503
Program Control Type		ASEL-C-1-20①②-NP-2-0	Programmed operation is possible. Can operate up to 2 axes.	1500 points				→ P567

* This is for the single-axis ASEL.
 * ① is a placeholder for the encoder type (I: incremental, A: absolute).
 * ② is a placeholder for the code "HA" or "LA", when the high-acceleration/deceleration option or the energy-saving option is selected.

- Slider Type
- Mini
- Standard
- Controllers Integrated
- Rod Type
- Mini
- Standard
- Controllers Integrated
- Table/Arm/Flat Type
- Mini
- Standard
- Gripper/Rotary Type
- Linear Servo Type
- Cleanroom Type
- Splash-Proof
- Controllers
- PMEC /AMEC
- PSEP /ASEP
- ROBO NET
- ERC2
- PCON
- ACON
- SCON
- PSEL
- ASEL
- SSEL
- XSEL
- Pulse Motor
- Servo Motor (24V)
- Servo Motor (200V)
- Linear Servo Motor

RCA-SA6C ROBO Cylinder Slider Type 58mm Width 24V Servo Motor Coupled

■ Configuration: **RCA** — **SA6C** — — **30** — — — — — —

Series — Type — Encoder — Motor — Lead — Stroke — Compatible Controllers — Cable Length — Option

I: Incremental
A: Absolute
* Absolute encoder models can only use ASEL.
When the actuator is used with the simple absolute encoder, the model is considered an incremental model.

30: 30W Servo motor

12: 12mm
6: 6mm
3: 3mm

50: 50mm
600: 600mm (50mm pitch increments)

A1: ACON
RACON
ASEL
A3: AMEC
ASEP

N: None
P: 1m
S: 3m
M: 5m
X : Custom Length
R : Robot Cable

See Options below

* See page Pre-35 for explanation of each code that makes up the configuration name.

For High Acceleration/Deceleration

(excluding the 3-mm lead model)

Power-saving

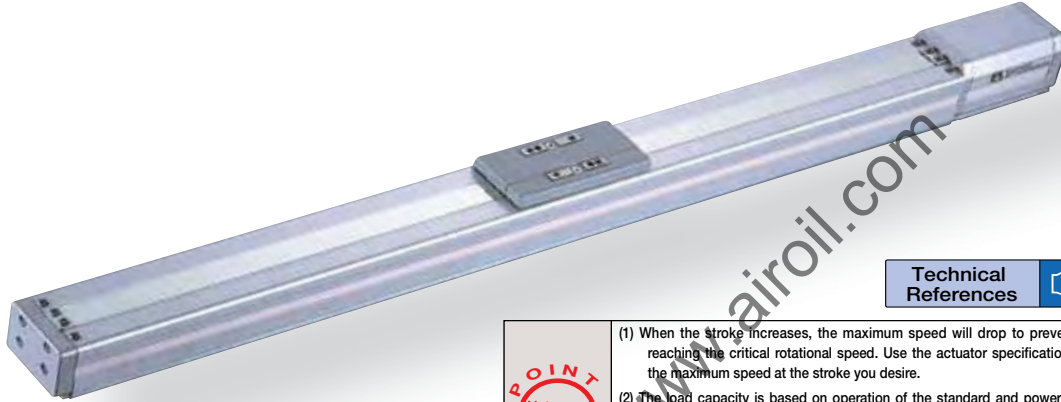

Technical References P. A-5

POINT
Notes on Selection

(1) When the stroke increases, the maximum speed will drop to prevent the ball screw from reaching the critical rotational speed. Use the actuator specification table below to check the maximum speed at the stroke you desire.

(2) The load capacity is based on operation of the standard and power-saving models at 0.3G (0.2G for 3mm-lead), and operation of the high acceleration/deceleration model at 1G (excluding the 3mm-lead model).
(Even when the acceleration/deceleration is dropped, the maximum load capacity values shown in the table below are the upper limits.)

Actuator Specifications

■ Lead and Load Capacity

Model	Motor Output (W)	Lead (mm)	Max. Load Capacity		Rated Thrust (N)	Stroke (mm)
			Horizontal (kg)	Vertical (kg)		
RCA-SA6C-①-30-12-②-③-④-⑤	30	12	6	1.5	24.2	50 ~ 600 (50mm increments)
RCA-SA6C-①-30-6-②-③-④-⑤		6	12	3	48.4	
RCA-SA6C-①-30-3-②-③-④-⑤		3	18	6	96.8	

■ Stroke and Maximum Speed

Stroke Lead	50 ~ 450 (50mm increments)	500 (mm)	550 (mm)	600 (mm)
12	800	760	640	540
6	400	380	320	270
3	200	190	160	135

Legend ① Encoder ② Stroke ③ Compatible controller ④ Cable length ⑤ Option (Unit: mm/s)

Encoder & Stroke List

② Stroke (mm)	Standard Price	
	① Encoder Type	
	Incremental	Absolute
	I	A
50	-	-
100	-	-
150	-	-
200	-	-
250	-	-
300	-	-
350	-	-
400	-	-
450	-	-
500	-	-
550	-	-
600	-	-

④ Cable List

Type	Cable Symbol	Standard Price
Standard	P (1m)	—
	S (3m)	—
	M (5m)	—
Special Lengths	X06 (6m) ~ X10 (10m)	—
	X11 (11m) ~ X15 (15m)	—
	X16 (16m) ~ X20 (20m)	—
		—
Robot Cable	R01 (1m) ~ R03 (3m)	—
	R04 (4m) ~ R05 (5m)	—
	R06 (6m) ~ R10 (10m)	—
	R11 (11m) ~ R15 (15m)	—
	R16 (16m) ~ R20 (20m)	—
		—

* See page A-39 for cables for maintenance.

⑤ Option List

Name	Option Code	See Page	Standard Price
Brake	B	→ A-25	—
Foot bracket	FT	→ A-29	—
For High Acceleration/Deceleration	HA	→ A-32	—
Home sensor	HS	→ A-32	—
Power-saving	LA	→ A-32	—
Reversed-home	NM	→ A-33	—
Slider Roller	SR	→ A-36	—

Actuator Specifications

Item	Description
Drive System	Ball screw Ø10mm C10 grade
Positioning Repeatability	±0.02mm
Lost Motion	0.1mm or less
Base	Material: Aluminum (white alumite treated)
Allowable Static Moment	Ma: 38.3 N·m Mb: 54.7 N·m Mc: 81.0 N·m
Allowable Dynamic Moment (*)	Ma: 8.9 N·m Mb: 12.7 N·m Mc: 18.6 N·m
Overhang Load Length	Ma direction: 220mm or less Mb-Mc direction: 220mm or less
Ambient Operating Temp./Humidity	0~40°C, 85% RH or less (non-condensing)

(*) Based on 5,000km travel life.

Directions of Allowable Load Moments

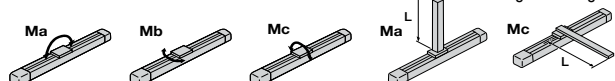

* The high-acceleration/deceleration option and the slider roller option cannot be used together.
* The high acceleration/deceleration option cannot be used on the 3mm-lead model.
* The high-acceleration/deceleration option and the power saving option cannot be used together.

Dimensions

CAD drawings can be downloaded from IAI website. www.intelligentactuator.com

For Special Orders P. A-9



- *1 A motor-encoder cable is connected here. See page A-39 for details on cables.
- *2 When homing, the slider moves to the ME; therefore, please watch for any interference with the surrounding objects.
ME: Mechanical end SE: Stroke end
- *3 Reference position for calculating the moment Ma.

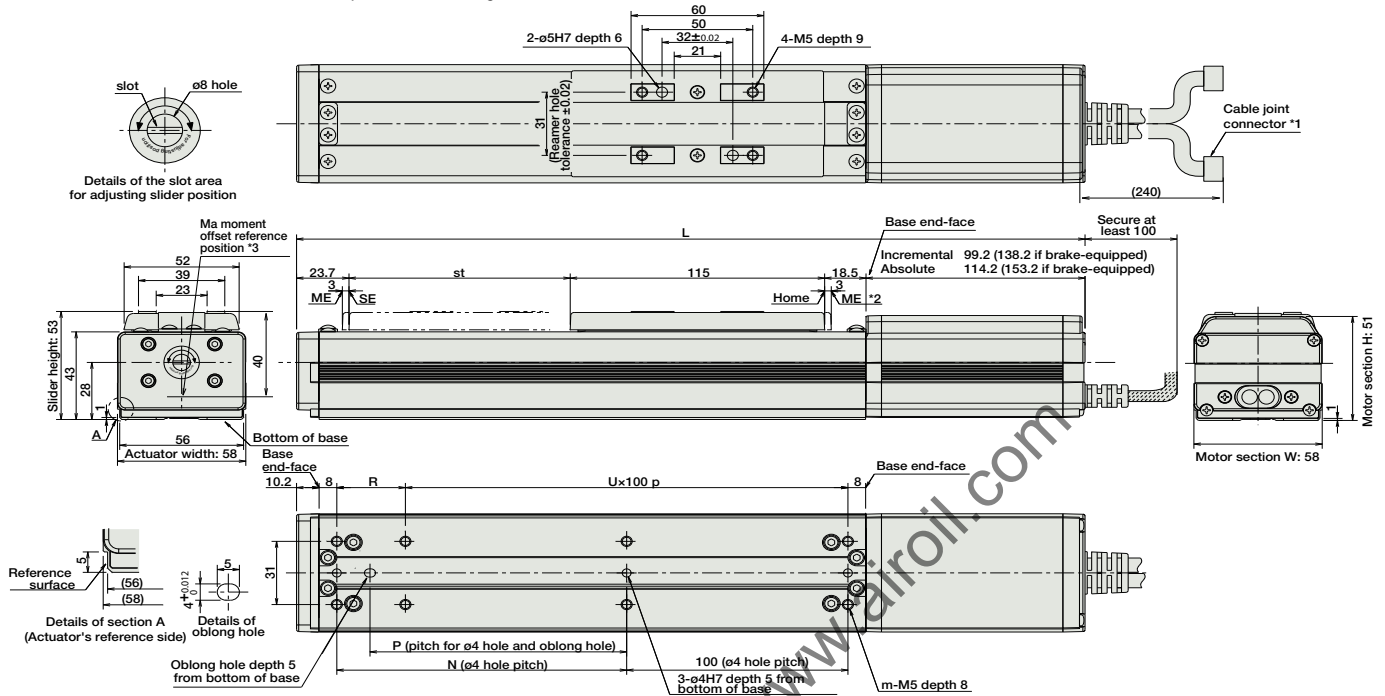

Dimensions/Weight by Stroke

* Brake-equipped models are heavier by 0.3kg.

L	Stroke		50	100	150	200	250	300	350	400	450	500	550	600
			Incremental	No Brake	306.4	356.4	406.4	456.4	506.4	556.4	606.4	656.4	706.4	756.4
	With Brake	345.4	395.4	445.4	495.4	545.4	595.4	645.4	695.4	745.4	795.4	845.4	895.4	
Absolute	No Brake	321.4	371.4	421.4	471.4	521.4	571.4	621.4	671.4	721.4	771.4	821.4	871.4	
	With Brake	360.4	410.4	460.4	510.4	560.4	610.4	660.4	710.4	760.4	810.4	860.4	910.4	
	N	81	131	181	231	281	331	381	431	481	531	581	631	
	P	66	116	166	216	266	316	366	416	466	516	566	616	
	R	81	31	81	31	81	31	81	31	81	31	81	31	
	U	1	2	2	3	3	4	4	5	5	6	6	7	
	m	6	8	8	10	10	12	12	14	14	16	16	18	
	Weight (kg)	1.4	1.6	1.8	2	2.2	2.4	2.6	2.8	3	3.2	3.4	3.6	

Compatible Controllers

The RCA series actuators can operate with the controllers below. Select the controller according to your usage.

Name	External View	Model	Description	Max. Positioning Points	Input Voltage	Power Supply Capacity	Standard Price	See Page
Solenoid Valve Type		AMEC-C-30I②-NP-2-1	Easy-to-use controller, even for beginners	3 points	AC100V	2.4A rated	—	→ P477
		ASEP-C-30I②-NP-2-0	Operable with same signal as solenoid valve. Supports both single and double solenoid types. No homing necessary with simple absolute type.					→ P487
Splash-Proof Solenoid Valve Type		ASEP-CW-30I②-NP-2-0						
Positioner Type		ACON-C-30I②-NP-2-0	Positioning is possible for up to 512 points	512 points	DC24V	(Standard) 1.3A rated 4.4A max.	—	
Safety-Compliant Positioner Type		ACON-CG-30I②-NP-2-0						
Pulse Train Input Type (Differential Line Driver)		ACON-PL-30I②-NP-2-0	Pulse train input type with differential line driver support	(-)	DC24V	(Power-saving) 1.3A rated 2.2A max.	—	→ P535
Pulse Train Input Type (Open Collector)		ACON-PO-30I②-NP-2-0	Pulse train input type with open collector support					
Serial Communication Type		ACON-SE-30I②-N-0-0	Dedicated to serial communication	64 points				
Field Network Type		RACON-30②	Dedicated to field network	768 points				→ P503
Program Control Type		ASEL-C-1-30①②-NP-2-0	Programmed operation is possible Can operate up to 2 axes	1500 points				→ P567

* This is for the single-axis ASEL.
 * ① is a placeholder for the encoder type (I: incremental, A: absolute).
 * ② is a placeholder for the code "HA" or "LA", when the high-acceleration/deceleration option or the energy-saving option is selected.

- Slider Type
- Mini
- Standard
- Controllers Integrated
- Rod Type
- Mini
- Standard
- Controllers Integrated
- Table/Arm/Flat Type
- Mini
- Standard
- Gripper/Rotary Type
- Linear Servo Type
- Cleanroom Type
- Splash-Proof
- Controllers
- PMEC/AMEC
- PSEP/ASEP
- ROBO NET
- ERC2
- PCON
- ACON
- SCON
- PSEL
- ASEL
- SSEL
- XSEL
- Pulse Motor
- Servo Motor (24V)
- Servo Motor (200V)
- Linear Servo Motor

RCA-SA4D

ROBO Cylinder Slider Type 40mm Width 24V Servo Motor Coupled

■ Configuration: **RCA** — **SA4D** — — **20** — — — — —

Series — Type — Encoder — Motor — Lead — Stroke — Compatible Controllers — Cable Length — Option

I: Incremental
A: Absolute
20: 20W Servo motor
10: 10mm
5: 5mm
2.5: 2.5mm
50: 50mm
300: 300mm (50mm pitch increments)
A1: ACON
RACON
ASEL
A3: AMEC
ASEP
N: None
P: 1m
S: 3m
M: 5m
X : Custom Length
R : Robot Cable

* See page Pre-35 for explanation of each code that makes up the configuration name.

See Options below

Power-saving

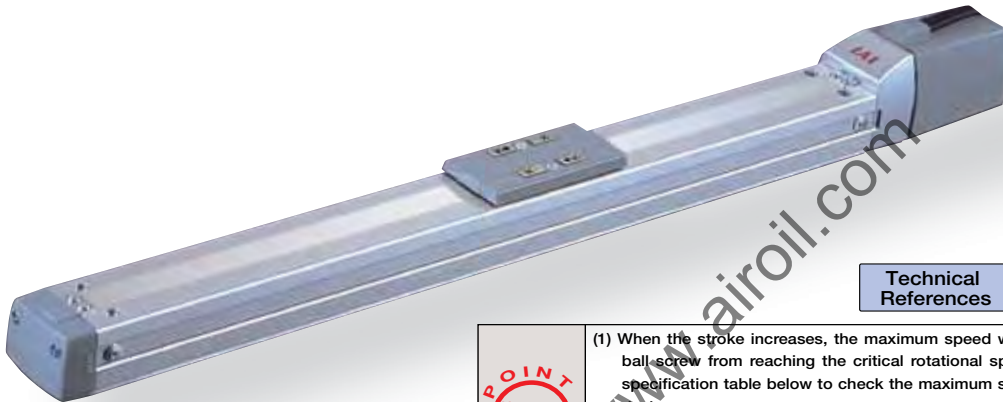

Technical References P. A-5

POINT
Notes on Selection

(1) When the stroke increases, the maximum speed will drop to prevent the ball screw from reaching the critical rotational speed. Use the actuator specification table below to check the maximum speed at the stroke you desire.

(2) The load capacity is based on operation at an acceleration of 0.3G (0.2G for the 2.5mm-lead model, or when used vertically). These values are the upper limits for the acceleration.

Actuator Specifications						Stroke and Maximum Speed	
■ Lead and Load Capacity						50 ~ 300 (50mm increments)	
Model	Motor Output (W)	Lead (mm)	Max. Load Capacity Horizontal (kg)	Max. Load Capacity Vertical (kg)	Rated Thrust (N)	Stroke Lead	50 ~ 300 (50mm increments)
RCA-SA4D-①-20-10-②-③-④-⑤	20	10	4	1	19.6	10	665
RCA-SA4D-①-20-5-②-③-④-⑤		5	6	2.5	39.2	5	330
RCA-SA4D-①-20-2.5-②-③-④-⑤		2.5	8	4.5	78.4	2.5	165

Legend ① Encoder ② Stroke ③ Compatible controller ④ Cable length ⑤ Option (Unit: mm/s)

Encoder & Stroke List		
② Stroke (mm)	Standard Price	
	① Encoder Type	
	Incremental	Absolute
50	-	-
100	-	-
150	-	-
200	-	-
250	-	-
300	-	-

④ Cable List		
Type	Cable Symbol	Standard Price
Standard	P (1m)	—
	S (3m)	—
	M (5m)	—
Special Lengths	X06 (6m) ~ X10 (10m)	—
	X11 (11m) ~ X15 (15m)	—
	X16 (16m) ~ X20 (20m)	—
	R01 (1m) ~ R03 (3m)	—
Robot Cable	R04 (4m) ~ R05 (5m)	—
	R06 (6m) ~ R10 (10m)	—
	R11 (11m) ~ R15 (15m)	—
	R16 (16m) ~ R20 (20m)	—

* See page A-39 for cables for maintenance.

⑤ Option List			
Name	Option Code	See Page	Standard Price
Brake (Cable exiting end)	BE	→ A-25	—
Brake (Cable exiting left)	BL	→ A-25	—
Brake (Cable exiting right)	BR	→ A-25	—
Foot bracket	FT	→ A-29	—
Power-saving	LA	→ A-32	—
Reversed-home	NM	→ A-33	—

Actuator Specifications	
Item	Description
Drive System	Ball screw Ø8mm C10 grade
Positioning Repeatability	±0.02mm
Lost Motion	0.1mm or less
Base	Material: Aluminum (white alumite treated)
Allowable Static Moment	Ma: 6.9 N·m Mb: 9.9 N·m Mc: 17.0 N·m
Allowable Dynamic Moment (*)	Ma: 2.7 N·m Mb: 3.9 N·m Mc: 6.8 N·m
Overhang Load Length	Ma direction: 120mm or less Mb-Mc direction: 120mm or less
Ambient Operating Temp./Humidity	0~40°C, 85% RH or less (non-condensing)

(*) Based on 5,000km travel life.

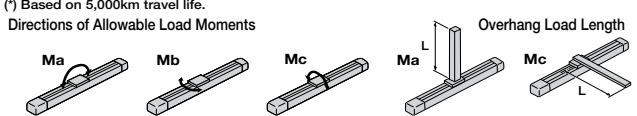

Dimensions

CAD drawings can be downloaded from IAI website. www.intelligentactuator.com

For Special Orders P. A-9

2D CAD

* Note that in order to change the orientation of the home, arrangements must be made to send in the product to IAI.
 * In the reversed-home model (NM), the new home is set 2.2mm in from the ME opposite of the motor-side.

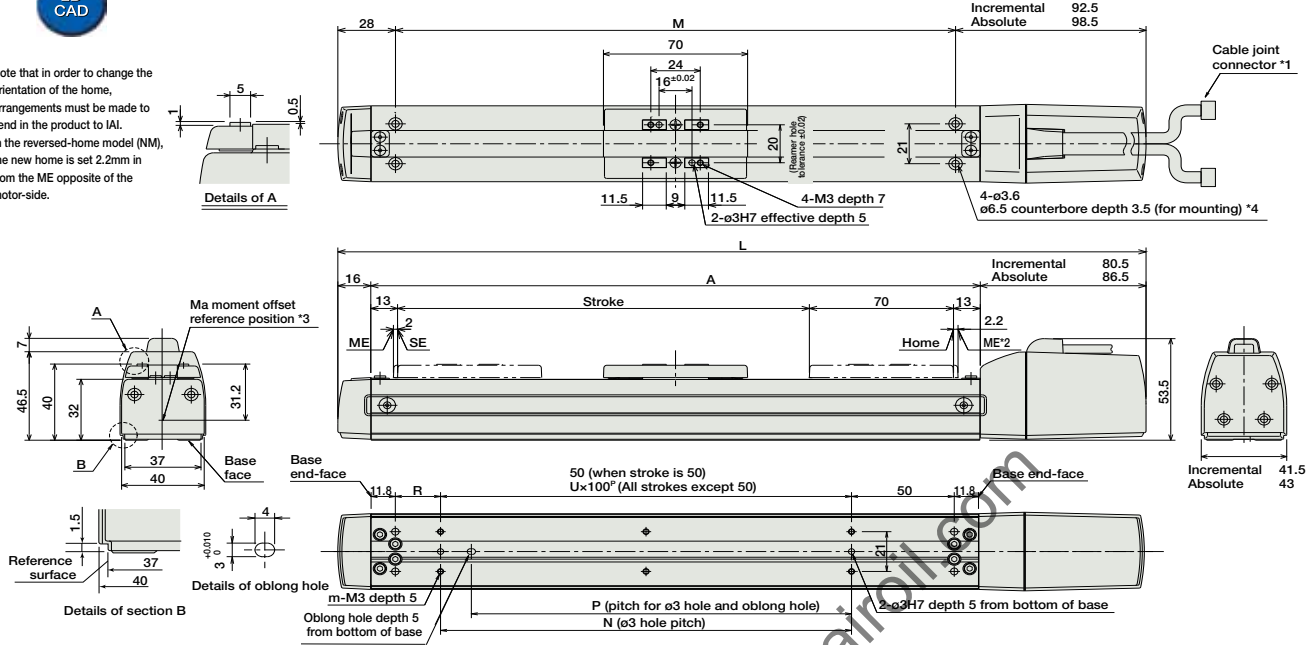

- *1 A motor-encoder cable is connected here. See page A-39 for details on cables.
- *2 When homing, the slider moves to the ME; therefore, please watch for any interference with the surrounding objects.
ME: Mechanical end SE: Stroke end
- *3 Reference position for calculating the moment Ma.
- *4 If the actuator is secured using only the mounting holes provided on the top surface of the base, the base may twist to cause abnormal sliding of the slider, or may produce abnormal noise. Therefore, when using the mounting holes on the top surface of the base, keep the stroke at 200mm or less.

■ Dimensions/Weight by Stroke

Stroke	50	100	150	200	250	300	
L	Incremental	242.5	292.5	342.5	392.5	442.5	492.5
	Absolute	248.5	298.5	348.5	398.5	448.5	498.5
A	146	196	246	296	346	396	
M	122	172	222	272	322	372	
N	50	100	100	200	200	300	
P	35	85	85	185	185	285	
R	22	22	72	22	72	22	
U	-	1	1	2	2	3	
m	4	4	4	6	6	8	
Weight (kg)	0.6	0.7	0.8	0.9	1.0	1.1	

* Adding a brake increases the actuator's overall length (L) by 28mm (41.3mm with the cable coming out its end), and its weight by 0.2kg.

③ Compatible Controllers

The RCA series actuators can operate with the controllers below. Select the controller according to your usage.

Name	External View	Model	Description	Max. Positioning Points	Input Voltage	Power Supply Capacity	Standard Price	See Page
Solenoid Valve Type		AMEC-C-20①②-NP-2-1	Easy-to-use controller, even for beginners	3 points	AC100V	2.4A rated	—	→ P477
		ASEP-C-20①②-NP-2-0	Operable with same signal as solenoid valve. Supports both single and double solenoid types. No homing necessary with simple absolute type.					
Splash-Proof Solenoid Valve Type		ASEP-CW-20①②-NP-2-0						→ P487
Positioner Type		ACON-C-20①②-NP-2-0	Positioning is possible for up to 512 points	512 points	DC24V	(Standard) 1.3A rated 4.4A max.	—	
Safety-Compliant Positioner Type		ACON-CG-20①②-NP-2-0						
Pulse Train Input Type (Differential Line Driver)		ACON-PL-20①②-NP-2-0	Pulse train input type with differential line driver support	(-)	DC24V	(Power-saving) 1.3A rated 2.5A max.	—	→ P535
Pulse Train Input Type (Open Collector)		ACON-PO-20①②-NP-2-0	Pulse train input type with open collector support					
Serial Communication Type		ACON-SE-20①②-N-0-0	Dedicated to serial communication	64 points				
Field Network Type		RACON-20②	Dedicated to field network	768 points				→ P503
Program Control Type		ASEL-C-1-20①②-NP-2-0	Programmed operation is possible Can operate up to 2 axes	1500 points				→ P567

* This is for the single-axis ASEL.
 * ① is a placeholder for the encoder type (I: incremental, A: absolute).
 * ② is a placeholder for the code "LA" when the power-saving option is specified.

RCA-SA5D

ROBO Cylinder Slider Type 52mm Width 24V Servo Motor
Motor Built-In (Direct-Coupled)

■ Configuration: **RCA** — **SA5D** — — **20** — — — — —

Series — Type — Encoder — Motor — Lead — Stroke — Compatible Controllers — Cable Length — Option

I: Incremental
A: Absolute
* Absolute encoder models can only use ASEL.
When the actuator is used with the simple absolute encoder, the model is considered an incremental model.

20: 20W Servo motor

12: 12mm
6: 6mm
3: 3mm

50: 50mm
500: 500mm (50mm pitch increments)

A1: ACON
RACON
ASEL
A3: AMEC
ASEP

N : None
P : 1m
S : 3m
M : 5m
X : Custom Length
R : Robot Cable

See Options below

* See page Pre-35 for explanation of each code that makes up the configuration name.

Power-saving

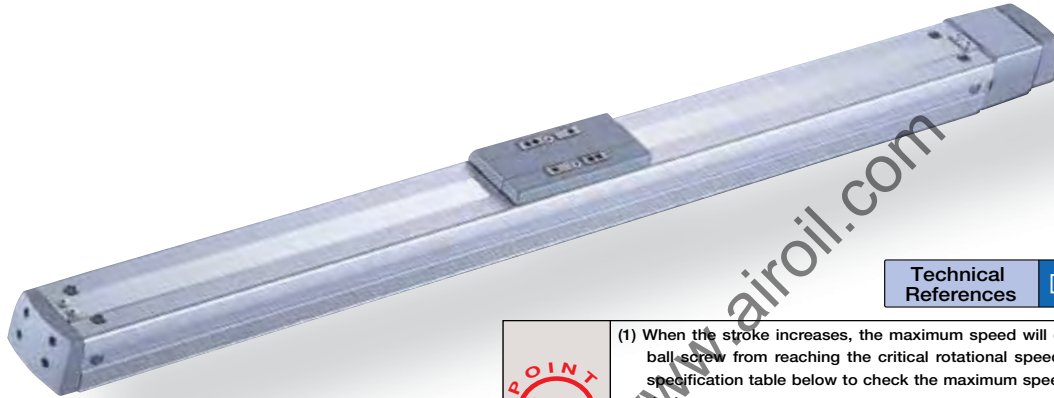

Technical References P. A-5

POINT
Notes on Selection

(1) When the stroke increases, the maximum speed will drop to prevent the ball screw from reaching the critical rotational speed. Use the actuator specification table below to check the maximum speed at the stroke you desire.

(2) The load capacity is based on operation at an acceleration of 0.3G (0.2G for the 3mm-lead model). These values are the upper limits for the acceleration.

Actuator Specifications

Lead and Load Capacity

Model	Motor Output (W)	Lead (mm)	Max. Load Capacity		Rated Thrust (N)	Stroke (mm)
			Horizontal (kg)	Vertical (kg)		
RCA-SA5D-①-20-12-②-③-④-⑤		12	4	1	16.7	50 ~ 500 (50mm increments)
RCA-SA5D-①-20-6-②-③-④-⑤	20	6	8	2	33.3	
RCA-SA5D-①-20-3-②-③-④-⑤		3	12	4	65.7	

Stroke and Maximum Speed

Stroke Lead	50 ~ 450 (50mm increments)	500 (mm)
	12	800
6	400	380
3	200	190

Legend ① Encoder ② Stroke ③ Compatible controller ④ Cable length ⑤ Option (Unit: mm/s)

Encoder & Stroke List

② Stroke (mm)	Standard Price	
	① Encoder Type	
	Incremental	Absolute
50	I	A
100	-	-
150	-	-
200	-	-
250	-	-
300	-	-
350	-	-
400	-	-
450	-	-
500	-	-

④ Cable List

Type	Cable Symbol	Standard Price
Standard	P (1m)	—
	S (3m)	—
	M (5m)	—
Special Lengths	X06 (6m) ~ X10 (10m)	—
	X11 (11m) ~ X15 (15m)	—
	X16 (16m) ~ X20 (20m)	—
	R01 (1m) ~ R03 (3m)	—
Robot Cable	R04 (4m) ~ R05 (5m)	—
	R06 (6m) ~ R10 (10m)	—
	R11 (11m) ~ R15 (15m)	—
	R16 (16m) ~ R20 (20m)	—

* See page A-39 for cables for maintenance.

⑤ Option List

Name	Option Code	See Page	Standard Price
Brake (Cable exiting end)	BE	→ A-25	—
Brake (Cable exiting left)	BL	→ A-25	—
Brake (Cable exiting right)	BR	→ A-25	—
Foot bracket	FT	→ A-29	—
Power-saving	LA	→ A-32	—
Reversed-home	NM	→ A-33	—
Slider Roller	SR	→ A-36	—

Actuator Specifications

Item	Description
Drive System	Ball screw Ø10mm C10 grade
Positioning Repeatability	±0.02mm
Lost Motion	0.1mm or less
Base	Material: Aluminum (white alumite treated)
Allowable Static Moment	Ma: 18.6 N·m Mb: 26.6 N·m Mc: 47.5 N·m
Allowable Dynamic Moment (*)	Ma: 4.9 N·m Mb: 6.8 N·m Mc: 11.7 N·m
Overhang Load Length	Ma direction: 150mm or less Mb-Mc direction: 150mm or less
Ambient Operating Temp./Humidity	0~40°C, 85% RH or less (non-condensing)

(*) Based on 5,000km travel life.

Directions of Allowable Load Moments

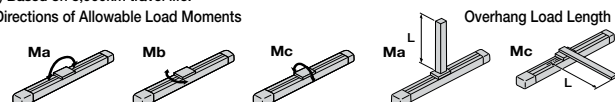

Dimensions

CAD drawings can be downloaded from IAI website. www.intelligentactuator.com



- *1 A motor-encoder cable is connected here. See page A-39 for details on cables.
 - *2 When homing, the slider moves to the ME; therefore, please watch for any interference with the surrounding objects.
- ME: Mechanical end SE: Stroke end

For Special Orders P. A-9

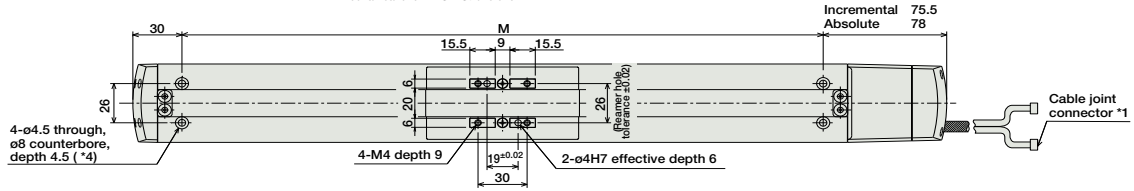

- *3 Reference position for calculating the moment Ma.
- *4 If the actuator is secured using only the mounting holes provided on the top surface of the base, the base may twist to cause abnormal sliding of the slider, or may produce abnormal noise. Therefore, when using the mounting holes on the top surface of the base, keep the stroke at 300mm or less.

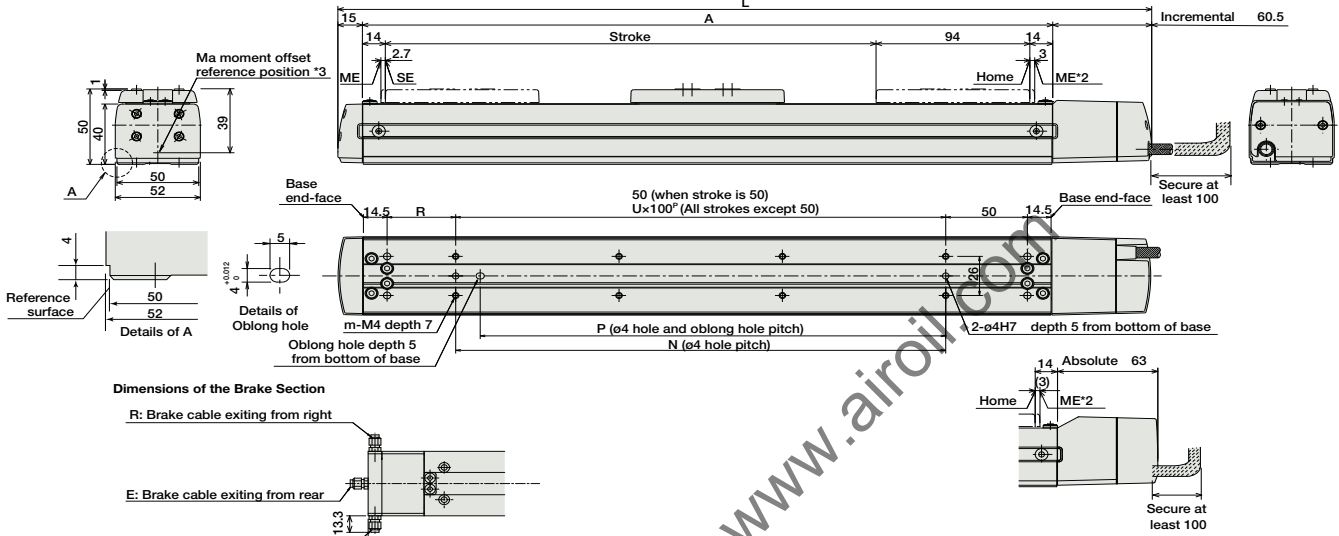

Dimensions of the Brake Section

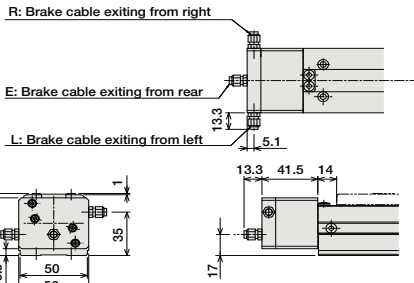

* Adding a brake increases the actuator's overall length (L) by 26.5mm (39.8mm with the cable coming out its end), and its weight by 0.3kg.

■ Dimensions/Weight by Stroke

Stroke	50	100	150	200	250	300	350	400	450	500
L	Incremental	247.5	297.5	347.5	397.5	447.5	497.5	547.5	597.5	647.5
	Absolute	250	300	350	400	450	500	550	600	650
A	172	222	272	322	372	422	472	522	572	622
M	142	192	242	292	342	392	442	492	542	592
N	50	100	100	200	200	300	300	400	400	500
P	35	85	85	185	185	285	285	385	385	485
R	42	42	92	42	92	42	92	42	92	42
U	-	1	1	2	2	3	3	4	4	5
m	4	4	4	6	6	8	8	10	10	12
Weight (kg)	1.2	1.3	1.4	1.5	1.6	1.7	1.8	1.9	2.0	2.1

③ Compatible Controllers

The RCA series actuators can operate with the controllers below. Select the controller according to your usage.

Name	External View	Model	Description	Max. Positioning Points	Input Voltage	Power Supply Capacity	Standard Price	See Page		
Solenoid Valve Type		AMEC-C-20②-NP-2-1	Easy-to-use controller, even for beginners	3 points	DC24V	(Standard) 1.3A rated 4.4A max. (Power-saving) 1.3A rated 2.5A max.	-	→ P477		
		ASEP-C-20②-NP-2-0	Operable with same signal as solenoid valve. Supports both single and double solenoid types. No homing necessary with simple absolute type.						-	→ P487
Splash-Proof Solenoid Valve Type		ASEP-CW-20②-NP-2-0								
Positioner Type		ACON-C-20②-NP-2-0	Positioning is possible for up to 512 points	512 points						
Safety-Compliant Positioner Type		ACON-CG-20②-NP-2-0								
Pulse Train Input Type (Differential Line Driver)		ACON-PL-20②-NP-2-0	Pulse train input type with differential line driver support	(-)						→ P535
Pulse Train Input Type (Open Collector)		ACON-PO-20②-NP-2-0	Pulse train input type with open collector support							
Serial Communication Type		ACON-SE-20②-N-0-0	Dedicated to serial communication	64 points						
Field Network Type		RACON-20②	Dedicated to field network	768 points						→ P503
Program Control Type		ASEL-C-1-20①②-NP-2-0	Programmed operation is possible. Can operate up to 2 axes	1500 points						→ P567

* This is for the single-axis ASEL.

* ① is a placeholder for the encoder type (I: incremental, A: absolute).

* ② is a placeholder for the code "LA" when the power-saving option is specified.

RCA-SA6D

ROBO Cylinder Slider Type 52mm Width 24V Servo Motor
Motor Built-In (Direct-Coupled)

■ Configuration: **RCA** — **SA6D** — — **30** — — — — —

Series — Type — Encoder — Motor — Lead — Stroke — Compatible Controllers — Cable Length — Option

I: Incremental 30: 30W Servo motor
A: Absolute
* Absolute encoder models can only use ASEL.
When the actuator is used with the simple absolute encoder, the model is considered an incremental model.

12: 12mm
6: 6mm
3: 3mm

50: 50mm
600: 600mm (50mm pitch increments)

A1: ACON
RACON
ASEL
A3: AMEC
ASEP

N: None
P: 1m
S: 3m
M: 5m
X : Custom Length
R : Robot Cable

See Options below

* See page Pre-35 for explanation of each code that makes up the configuration name.

Power-saving

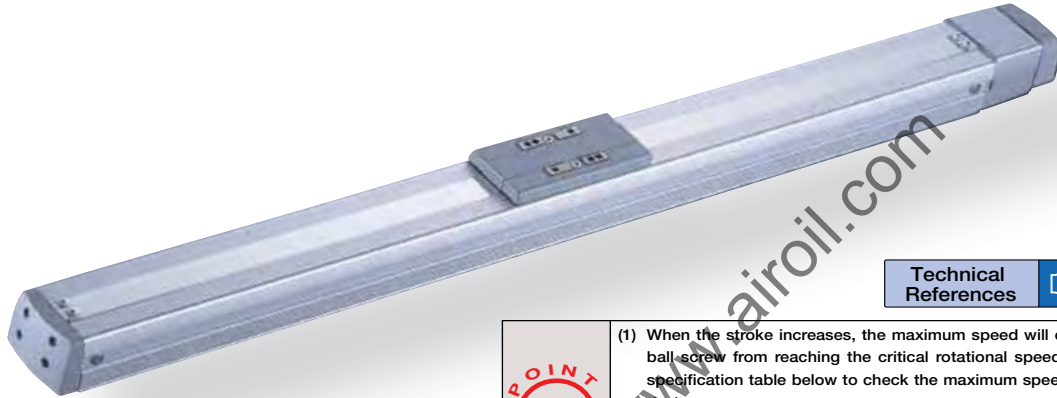

Technical References P. A-5

POINT
Notes on Selection

(1) When the stroke increases, the maximum speed will drop to prevent the ball screw from reaching the critical rotational speed. Use the actuator specification table below to check the maximum speed at the stroke you desire.

(2) The load capacity is based on operation at an acceleration of 0.3G (0.2G for the 3mm-lead model). These values are the upper limits for the acceleration.

Actuator Specifications

■ Lead and Load Capacity

Model	Motor Output (W)	Lead (mm)	Max. Load Capacity		Rated Thrust (N)	Stroke (mm)
			Horizontal (kg)	Vertical (kg)		
RCA-SA6D-①-30-12-②-③-④-⑤	30	12	6	1.5	24.2	50 ~ 600 (50mm increments)
RCA-SA6D-①-30-6-②-③-④-⑤		6	12	3	48.4	
RCA-SA6D-①-30-3-②-③-④-⑤		3	18	6	96.8	

■ Stroke and Maximum Speed

Stroke Lead	50 ~ 450 (50mm increments)	500 (mm)	550 (mm)	600 (mm)
12	800	760	640	540
6	400	380	320	270
3	200	190	160	135

Legend ① Encoder ② Stroke ③ Compatible controller ④ Cable length ⑤ Option (Unit: mm/s)

Encoder & Stroke List

② Stroke (mm)	Standard Price	
	① Encoder Type	
	Incremental	Absolute
	I	A
50	-	-
100	-	-
150	-	-
200	-	-
250	-	-
300	-	-
350	-	-
400	-	-
450	-	-
500	-	-
550	-	-
600	-	-

④ Cable List

Type	Cable Symbol	Standard Price
Standard	P (1m)	—
	S (3m)	—
	M (5m)	—
Special Lengths	X06 (6m) ~ X10 (10m)	—
	X11 (11m) ~ X15 (15m)	—
	X16 (16m) ~ X20 (20m)	—
	R01 (1m) ~ R03 (3m)	—
Robot Cable	R04 (4m) ~ R05 (5m)	—
	R06 (6m) ~ R10 (10m)	—
	R11 (11m) ~ R15 (15m)	—
	R16 (16m) ~ R20 (20m)	—

* See page A-39 for cables for maintenance.

⑤ Option List

Name	Option Code	See Page	Standard Price
Brake (Cable exiting end)	BE	→ A-25	—
Brake (Cable exiting left)	BL	→ A-25	—
Brake (Cable exiting right)	BR	→ A-25	—
Foot bracket	FT	→ A-29	—
Power-saving	LA	→ A-32	—
Reversed-home	NM	→ A-33	—
Slider Roller	SR	→ A-36	—

Actuator Specifications

Item	Description
Drive System	Ball screw Ø10mm C10 grade
Positioning Repeatability	±0.02mm
Lost Motion	0.1mm or less
Base	Material: Aluminum (white alumite treated)
Allowable Static Moment	Ma: 38.3N·m Mb: 54.7N·m Mc: 81.0N·m
Allowable Dynamic Moment (*)	Ma: 8.9N·m Mb: 12.7N·m Mc: 18.6N·m
Overhang Load Length	Ma direction: 220mm or less Mb-Mc direction: 220mm or less
Ambient Operating Temp./Humidity	0~40°C, 85% RH or less (non-condensing)

(*) Based on 5,000km travel life.

Directions of Allowable Load Moments

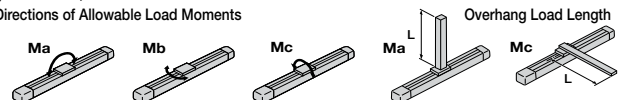

Dimensions

CAD drawings can be downloaded from IAI website. www.intelligentactuator.com

For Special Orders P. A-9



* Note that in order to change the orientation of the home, arrangements must be made to send in the product to IAI.
 * In the reversed-home model (NM), the new home is set 3mm from the ME opposite of the motor-side.

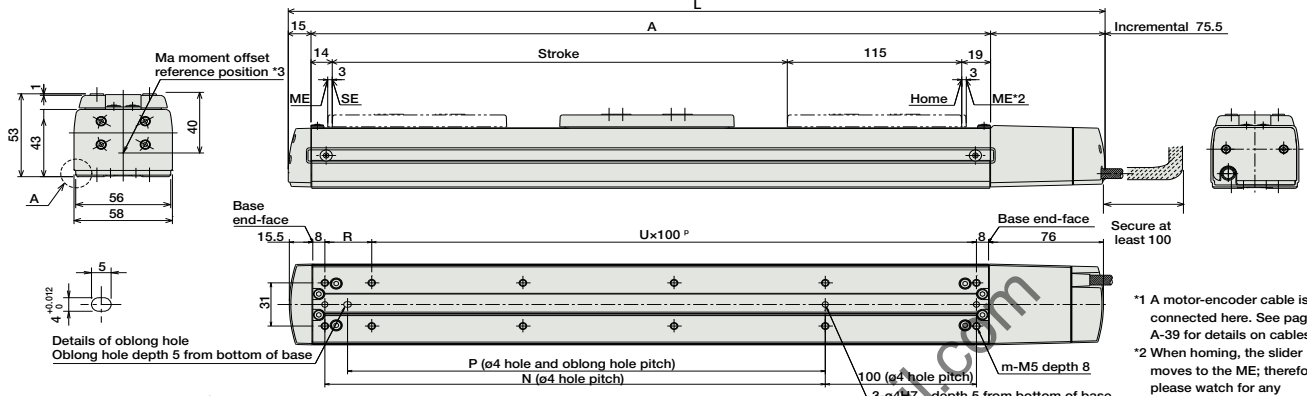
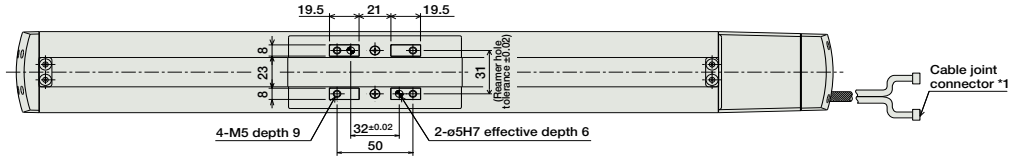

*1 A motor-encoder cable is connected here. See page A-39 for details on cables.
 *2 When homing, the slider moves to the ME; therefore, please watch for any interference with the surrounding objects.
 ME: Mechanical end
 SE: Stroke end
 *3 Reference position for calculating the moment Ma.

Dimensions of the Brake Section

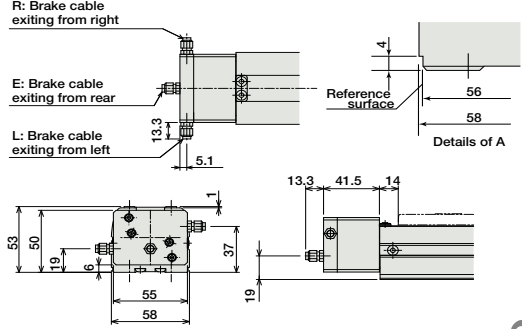

* Adding a brake increases the actuator's overall length (L) by 26.5mm (39.8mm with the cable coming out its end), and its weight by 0.3kg.

Dimensions/Weight by Stroke

Stroke	50	100	150	200	250	300	350	400	450	500	550	600
L Incremental	288.5	338.5	388.5	438.5	488.5	538.5	588.5	638.5	688.5	738.5	788.5	838.5
L Absolute	292.5	342.5	392.5	442.5	492.5	542.5	592.5	642.5	692.5	742.5	792.5	842.5
A	198	248	298	348	398	448	498	548	598	648	698	748
N	81	131	181	231	281	331	381	431	481	531	581	631
P	66	116	166	216	266	316	366	416	466	516	566	616
R	81	31	81	31	81	31	81	31	81	31	81	31
U	1	2	2	3	3	4	4	5	5	6	6	7
m	6	8	8	10	10	12	12	14	14	16	16	18
Weight (kg)	1.3	1.5	1.7	1.9	2.1	2.3	2.5	2.7	2.9	3.1	3.3	3.5

Compatible Controllers

The RCA series actuators can operate with the controllers below. Select the controller according to your usage.

Name	External View	Model	Description	Max. Positioning Points	Input Voltage	Power Supply Capacity	Standard Price	See Page
Solenoid Valve Type		AMEC-C-30I②-NP-2-1	Easy-to-use controller, even for beginners	3 points	AC100V	2.4A rated	-	→ P477
		ASEP-C-30I②-NP-2-0	Operable with same signal as solenoid valve. Supports both single and double solenoid types. No homing necessary with simple absolute type.					
Splash-Proof Solenoid Valve Type		ASEP-CW-30I②-NP-2-0						
Positioner Type		ACON-C-30I②-NP-2-0	Positioning is possible for up to 512 points	512 points	DC24V	(Standard) 1.3A rated 4.4A max.	-	→ P535
Safety-Compliant Positioner Type		ACON-CG-30I②-NP-2-0						
Pulse Train Input Type (Differential Line Driver)		ACON-PL-30I②-NP-2-0	Pulse train input type with differential line driver support	(-)	DC24V	(Power-saving) 1.3A rated 2.2A max.	-	→ P535
Pulse Train Input Type (Open Collector)		ACON-PO-30I②-NP-2-0	Pulse train input type with open collector support					
Serial Communication Type		ACON-SE-30I②-N-0-0	Dedicated to serial communication	64 points				
Field Network Type		RACON-30②	Dedicated to field network	768 points				→ P503
Program Control Type		ASEL-C-1-30①②-NP-2-0	Programmed operation is possible. Can operate up to 2 axes	1500 points				→ P567

* This is for the single-axis ASEL.
 * ① is a placeholder for the encoder type (I: incremental, A: absolute).
 * ② is a placeholder for the code "LA" when the power-saving option is specified.

- Slider Type
- Mini
- Standard
- Controllers Integrated
- Rod Type
- Mini
- Standard
- Controllers Integrated
- Table/Arm/Flat Type
- Mini
- Standard
- Gripper/Rotary Type
- Linear Servo Type
- Cleanroom Type
- Splash Proof
- Controllers
- PMEC/AMEC
- PSEP/ASEP
- ROBO NET
- ERC2
- PCON
- ACON
- SCON
- PSEL
- ASEL
- SSEL
- XSEL
- Pulse Motor
- Servo Motor (24V)
- Servo Motor (200V)
- Linear Servo Motor

RCA-SS4D

ROBO Cylinder Slider Type 40mm Width 24V Servo Motor
Motor Built-In (Direct-Coupled) Steel Base

■ Configuration: **RCA** — **SS4D** — **I** — **20** — — — — —

Series — Type — Encoder — Motor — Lead — Stroke — Compatible Controllers — Cable Length — Option

I: Incremental
* Simple absolute encoder models are labeled as "I".

20: 20W Servo motor

10: 10mm
5: 5mm
2.5: 2.5mm

50: 50mm
300: 300mm (50mm pitch increments)

A1: ACON
RACON
ASEL

A3: AMEC
ASEP

N : None
P : 1m
S : 3m
M : 5m
X : Custom Length
R : Robot Cable

See Options below

* See page Pre-35 for explanation of each code that makes up the configuration name.

Power-saving

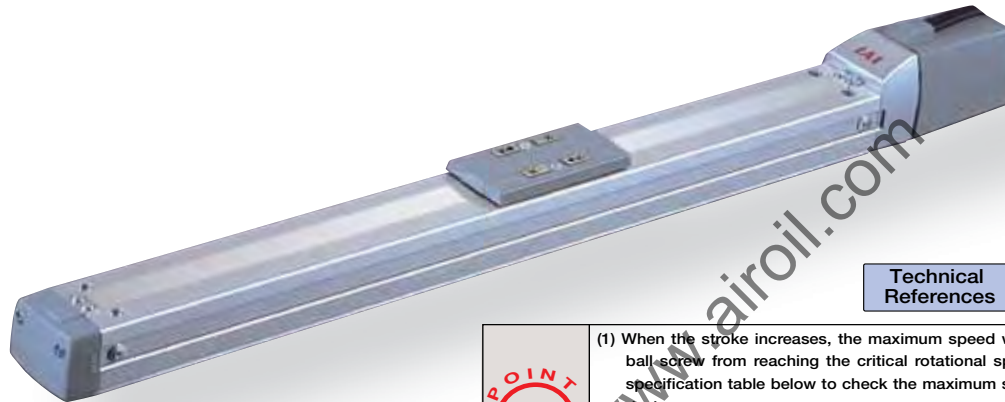

Technical References P. A-5

POINT
Notes on Selection

(1) When the stroke increases, the maximum speed will drop to prevent the ball screw from reaching the critical rotational speed. Use the actuator specification table below to check the maximum speed at the stroke you desire.

(2) The load capacity is based on operation at an acceleration of 0.3G (0.2G for the 2.5mm-lead model, or when used vertically). These values are the upper limits for the acceleration.

Actuator Specifications

■ Lead and Load Capacity

Model	Motor Output (W)	Lead (mm)	Max. Load Capacity		Rated Thrust (N)	Stroke (mm)
			Horizontal (kg)	Vertical (kg)		
RCA-SS4D-I-20-10-①-②-③-④	20	10	4	1	19.6	50 ~ 300 (50mm increments)
RCA-SS4D-I-20-5-①-②-③-④		5	6	2.5	39.2	
RCA-SS4D-I-20-2.5-①-②-③-④		2.5	8	4.5	78.4	

■ Stroke and Maximum Speed

Stroke Lead	50 ~ 300 (50mm increments)	
	Stroke	50 ~ 300 (50mm increments)
10		665
5		330
2.5		165

Legend ① Stroke ② Compatible controller ③ Cable length ④ Options

(Unit: mm/s)

① Stroke List

Stroke (mm)	Standard Price
50	—
100	—
150	—
200	—
250	—
300	—

③ Cable List

Type	Cable Symbol	Standard Price
Standard	P (1m)	—
	S (3m)	—
	M (5m)	—
Special Lengths	X06 (6m) ~ X10 (10m)	—
	X11 (11m) ~ X15 (15m)	—
	X16 (16m) ~ X20 (20m)	—
Robot Cable	R01 (1m) ~ R03 (3m)	—
	R04 (4m) ~ R05 (5m)	—
	R06 (6m) ~ R10 (10m)	—
	R11 (11m) ~ R15 (15m)	—
	R16 (16m) ~ R20 (20m)	—

* See page A-39 for cables for maintenance.

④ Option List

Name	Option Code	See Page	Standard Price
Brake (Cable exiting end)	BE	→ A-25	—
Brake (Cable exiting left)	BL	→ A-25	—
Brake (Cable exiting right)	BR	→ A-25	—
Power-saving	LA	→ A-32	—
Reversed-home	NM	→ A-33	—

Actuator Specifications

Item	Description
Drive System	Ball screw Ø8mm C10 grade
Positioning Repeatability	±0.02mm
Lost Motion	0.1mm or less
Base	Material: Special alloy steel
Allowable Static Moment	Ma: 6.9 N·m Mb: 9.9 N·m Mc: 17.0 N·m
Allowable Dynamic Moment (*)	Ma: 2.7 N·m Mb: 3.9 N·m Mc: 6.8 N·m
Overhang Load Length	Ma direction: 120mm or less Mb-Mc direction: 120mm or less
Ambient Operating Temp./Humidity	0~40°C, 85% RH or less (non-condensing)

(*) Based on 5,000km travel life.

Directions of Allowable Load Moments

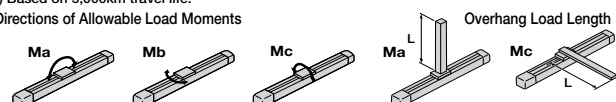

Dimensions

CAD drawings can be downloaded from IAI website. www.intelligentactuator.com

For Special Orders P. A-9



- * Note that in order to change the orientation of the home, arrangements must be made to send in the product to IAI.
- * In the reversed-home model (NM), the new home is set 2.2mm in from the ME opposite of the motor-side.

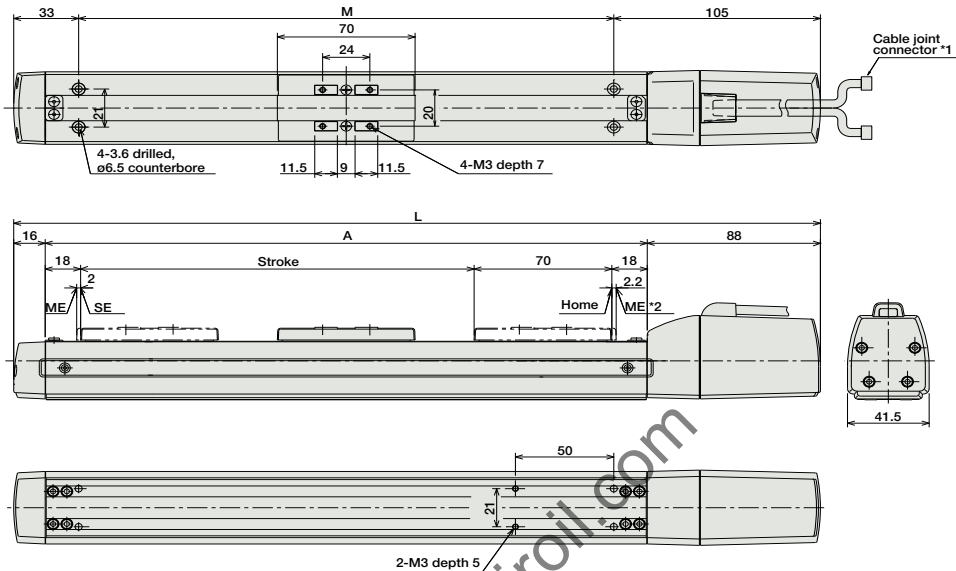

Dimensions of the Brake Section

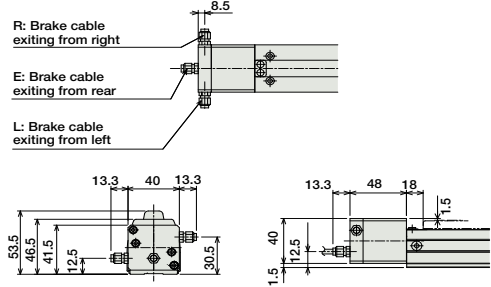

- *1 A motor-encoder cable is connected here. See page A-39 for details on cables.
- *2 When homing, the slider moves to the ME; therefore, please watch for any interference with the surrounding objects.
ME: Mechanical end SE: Stroke end
- *3 Reference position for calculating the moment Ma.

* Adding a brake increases the actuator's overall length (L) by 32mm (45.3mm with the cable coming out its end), and its weight by 0.2kg.

Dimensions/Weight by Stroke

Stroke	50	100	150	200	250	300
L	260	310	360	410	460	510
A	156	206	256	306	356	406
M	122	172	222	272	322	372
Weight (kg)	1.1	1.2	1.3	1.4	1.5	1.6

Compatible Controllers

The RCA series actuators can operate with the controllers below. Select the controller according to your usage.

Name	External View	Model	Description	Max. Positioning Points	Input Voltage	Power Supply Capacity	Standard Price	See Page				
Solenoid Valve Type		AMEC-C-20I②-NP-2-1	Easy-to-use controller, even for beginners	3 points	DC24V	(Standard) 1.3A rated 4.4A max. (Power-saving) 1.3A rated 2.5A max.	-	→ P477				
		ASEP-C-20I②-NP-2-0	Operable with same signal as solenoid valve. Supports both single and double solenoid types. No homing necessary with simple absolute type.									
Splash-Proof Solenoid Valve Type		ASEP-CW-20I②-NP-2-0										
Positioner Type		ACON-C-20I②-NP-2-0	Positioning is possible for up to 512 points	512 points								
Safety-Compliant Positioner Type		ACON-CG-20I②-NP-2-0										
Pulse Train Input Type (Differential Line Driver)		ACON-PL-20I②-NP-2-0	Pulse train input type with differential line driver support	(-)								→ P535
Pulse Train Input Type (Open Collector)		ACON-PO-20I②-NP-2-0	Pulse train input type with open collector support									
Serial Communication Type		ACON-SE-20I②-N-0-0	Dedicated to serial communication	64 points								
Field Network Type		RACON-20②	Dedicated to field network	768 points								→ P503
Program Control Type		ASEL-C-1-20I②-NP-2-0	Programmed operation is possible Can operate up to 2 axes	1500 points				→ P567				

* This is for the single-axis ASEL.
* ② is a placeholder for the code "LA" when the power-saving option is specified.

RCA-SS5D

ROBO Cylinder Slider Type 52mm Width 24V Servo Motor
Motor Built-In (Direct-Coupled) Steel Base

■ Configuration: **RCA** — **SS5D** — **I** — **20** — — — — —

Series — Type — Encoder — Motor — Lead — Stroke — Compatible Controllers — Cable Length — Option

I: Incremental
* Simple absolute encoder models are labeled as "I".

20: 20W Servo motor

12: 12mm
6: 6mm
3: 3mm

50: 50mm
500: 500mm (50mm pitch increments)

A1: ACON
RACON
ASEL
A3: AMEC
ASEP

N : None
P : 1m
S : 3m
M : 5m
X : Custom Length
R : Robot Cable

See Options below

* See page Pre-35 for explanation of each code that makes up the configuration name.

Power-saving

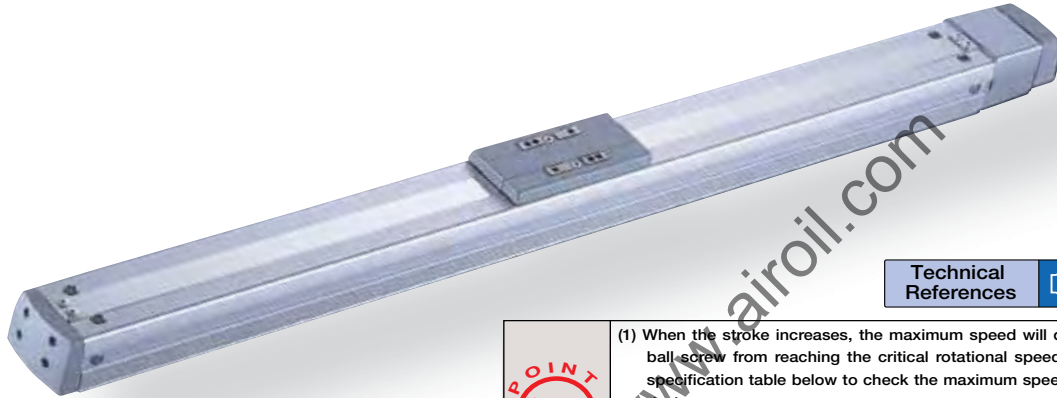

Technical References P. A-5

POINT
Notes on Selection

(1) When the stroke increases, the maximum speed will drop to prevent the ball screw from reaching the critical rotational speed. Use the actuator specification table below to check the maximum speed at the stroke you desire.

(2) The load capacity is based on operation at an acceleration of 0.3G (0.2G for the 3mm-lead model). These values are the upper limits for the acceleration.

Actuator Specifications

■ Lead and Load Capacity

Model	Motor Output (W)	Lead (mm)	Max. Load Capacity		Rated Thrust (N)	Stroke (mm)
			Horizontal (kg)	Vertical (kg)		
RCA-SS5D-I-20-12-①-②-③-④	20	12	4	1	16.7	50 ~ 500 (50mm increments)
RCA-SS5D-I-20-6-①-②-③-④		6	8	2	33.3	
RCA-SS5D-I-20-3-①-②-③-④		3	12	4	65.7	

■ Stroke and Maximum Speed

Stroke Lead	50 ~ 450 (50mm increments)	500 (mm)
	12	800
6	400	380
3	200	190

Legend ① Stroke ② Compatible controller ③ Cable length ④ Options (Unit: mm/s)

① Stroke List

Stroke (mm)	Standard Price
50	—
100	—
150	—
200	—
250	—
300	—
350	—
400	—
450	—
500	—

③ Cable List

Type	Cable Symbol	Standard Price
Standard	P (1m)	—
	S (3m)	—
	M (5m)	—
Special Lengths	X06 (6m) ~ X10 (10m)	—
	X11 (11m) ~ X15 (15m)	—
	X16 (16m) ~ X20 (20m)	—
	R01 (1m) ~ R03 (3m)	—
Robot Cable	R04 (4m) ~ R05 (5m)	—
	R06 (6m) ~ R10 (10m)	—
	R11 (11m) ~ R15 (15m)	—
	R16 (16m) ~ R20 (20m)	—

* See page A-39 for cables for maintenance.

④ Option List

Name	Option Code	See Page	Standard Price
Brake (Cable exiting end)	BE	→ A-25	—
Brake (Cable exiting left)	BL	→ A-25	—
Brake (Cable exiting right)	BR	→ A-25	—
Power-saving	LA	→ A-32	—
Reversed-home	NM	→ A-33	—
Slider Roller	SR	→ A-36	—

Actuator Specifications

Item	Description
Drive System	Ball screw Ø10mm C10 grade
Positioning Repeatability	±0.02mm
Lost Motion	0.1mm or less
Base	Material: Special alloy steel
Allowable Static Moment	Ma: 18.6 N·m Mb: 26.6 N·m Mc: 47.5 N·m
Allowable Dynamic Moment (*)	Ma: 4.9 N·m Mb: 6.8 N·m Mc: 11.7 N·m
Overhang Load Length	Ma direction: 150mm or less Mb-Mc direction: 150mm or less
Ambient Operating Temp./Humidity	0~40°C, 85% RH or less (non-condensing)

(*) Based on 5,000km travel life.

Directions of Allowable Load Moments

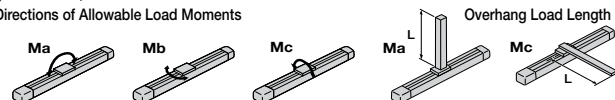

Dimensions

CAD drawings can be downloaded from IAI website. www.intelligentactuator.com

For Special Orders P. A-9

2D CAD

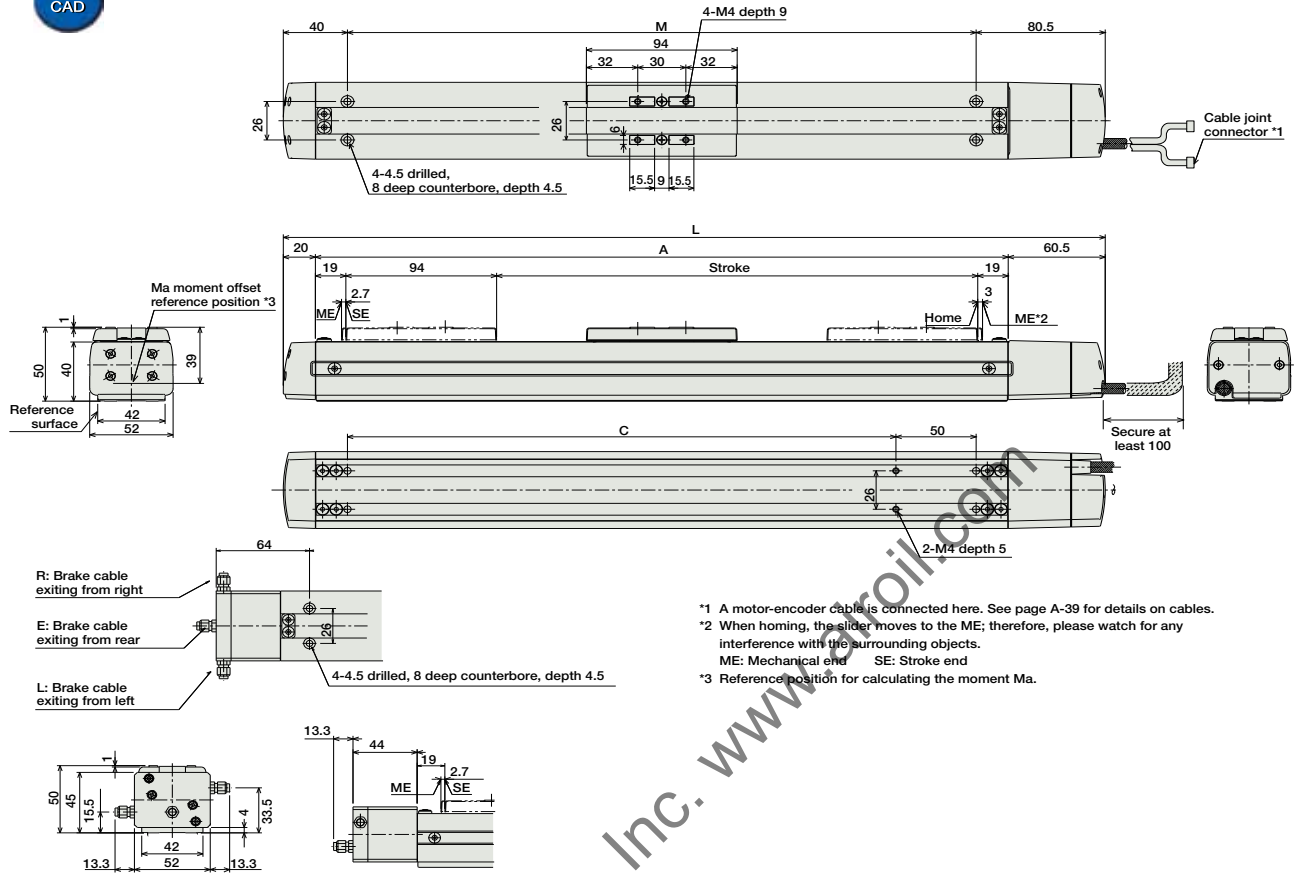

- *1 A motor-encoder cable is connected here. See page A-39 for details on cables.
- *2 When homing, the slider moves to the ME; therefore, please watch for any interference with the surrounding objects.
ME: Mechanical end SE: Stroke end
- *3 Reference position for calculating the moment Ma.

* Adding a brake will increase the actuator's overall length (L) by 24mm (37.3mm with the cable coming out from the end), and its weight by 0.3kg.

■ Dimensions/Weight by Stroke

Stroke	50	100	150	200	250	300	350	400	450	500
L	262.5	312.5	362.5	412.5	462.5	512.5	562.5	612.5	662.5	712.5
A	182	232	282	332	382	432	482	532	582	632
M	142	192	242	292	342	392	442	492	542	592
C	92	142	192	242	292	342	392	442	492	542
Weight (kg)	1.4	1.5	1.6	1.7	1.8	1.9	2.0	2.1	2.2	2.3

② Compatible Controllers

The RCA series actuators can operate with the controllers below. Select the controller according to your usage.

Name	External View	Model	Description	Max. Positioning Points	Input Voltage	Power Supply Capacity	Standard Price	See Page
Solenoid Valve Type		AMEC-C-20I②-NP-2-1	Easy-to-use controller, even for beginners	3 points	AC100V	2.4A rated	-	→ P477
		ASEP-C-20I②-NP-2-0	Operable with same signal as solenoid valve. Supports both single and double solenoid types. No homing necessary with simple absolute type.					
Splash-Proof Solenoid Valve Type		ASEP-CW-20I②-NP-2-0						
Positioner Type		ACON-C-20I②-NP-2-0	Positioning is possible for up to 512 points	512 points	DC24V	(Standard) 1.3A rated 4.4A max.	-	→ P535
Safety-Compliant Positioner Type		ACON-CG-20I②-NP-2-0						
Pulse Train Input Type (Differential Line Driver)		ACON-PL-20I②-NP-2-0	Pulse train input type with differential line driver support	(-)	DC24V	(Power-saving) 1.3A rated 2.5A max.	-	→ P535
Pulse Train Input Type (Open Collector)		ACON-PO-20I②-NP-2-0	Pulse train input type with open collector support					
Serial Communication Type		ACON-SE-20I②-N-0-0	Dedicated to serial communication	64 points				
Field Network Type		RACON-20②	Dedicated to field network	768 points				→ P503
Program Control Type		ASEL-C-1-20I②-NP-2-0	Programmed operation is possible Can operate up to 2 axes	1500 points				→ P567

* This is for the single-axis ASEL.
* ② is a placeholder for the code "LA" when the power-saving option is specified.

RCA-SS6D

ROBO Cylinder Slider Type 58mm Width 24V Servo Motor
Motor Built-In (Direct-Coupled) Steel Base

■ Configuration: **RCA** — **SS6D** — **I** — **30** — — — — —

Series — Type — Encoder — Motor — Lead — Stroke — Compatible Controllers — Cable Length — Option

I: Incremental
* Simple absolute encoder models are labeled as "I".

30: 30W Servo motor

12: 12mm
6: 6mm
3: 3mm

50: 50mm
600: 600mm (50mm pitch increments)

A1: ACON
RACON
ASEL
A3: AMEC
ASEP

N: None
P: 1m
S: 3m
M: 5m
X : Custom Length
R : Robot Cable

See Options below

* See page Pre-35 for explanation of each code that makes up the configuration name.

Power-saving

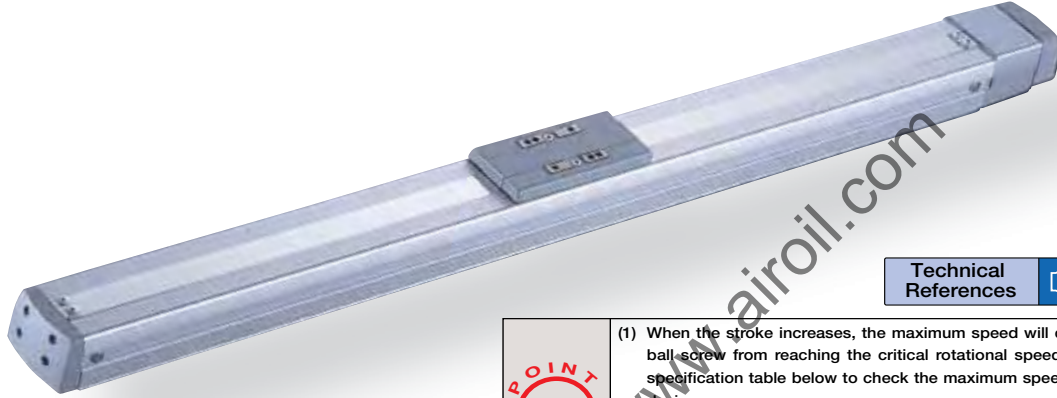

Technical References P. A-5

POINT
Notes on Selection

(1) When the stroke increases, the maximum speed will drop to prevent the ball screw from reaching the critical rotational speed. Use the actuator specification table below to check the maximum speed at the stroke you desire.

(2) The load capacity is based on operation at an acceleration of 0.3G (0.2G for the 3mm-lead model). These values are the upper limits for the acceleration.

Actuator Specifications

■ Lead and Load Capacity

Model	Motor Output (W)	Lead (mm)	Max. Load Capacity		Rated Thrust (N)	Stroke (mm)
			Horizontal (kg)	Vertical (kg)		
RCA-SS6D-I-30-12-①-②-③-④	30	12	6	1.5	24.2	50 ~ 600 (50mm increments)
RCA-SS6D-I-30-6-①-②-③-④		6	12	3	48.4	
RCA-SS6D-I-30-3-①-②-③-④		3	18	6	96.8	

■ Stroke and Maximum Speed

Stroke Lead	50 ~ 450 (50mm increments)	500 (mm)	550 (mm)	600 (mm)
	12	800	760	640
6	400	380	320	270
3	200	190	160	135

Legend ① Stroke ② Compatible controller ③ Cable length ④ Options (Unit: mm/s)

① Stroke List

Stroke (mm)	Standard Price
50	-
100	-
150	-
200	-
250	-
300	-
350	-
400	-
450	-
500	-
550	-
600	-

③ Cable List

Type	Cable Symbol	Standard Price
Standard	P (1m)	-
	S (3m)	-
	M (5m)	-
Special Lengths	X06 (6m) ~ X10 (10m)	-
	X11 (11m) ~ X15 (15m)	-
	X16 (16m) ~ X20 (20m)	-
Robot Cable	R01 (1m) ~ R03 (3m)	-
	R04 (4m) ~ R05 (5m)	-
	R06 (6m) ~ R10 (10m)	-
	R11 (11m) ~ R15 (15m)	-
	R16 (16m) ~ R20 (20m)	-

* See page A-39 for cables for maintenance.

④ Option List

Name	Option Code	See Page	Standard Price
Brake (Cable exiting end)	BE	→ A-25	-
Brake (Cable exiting left)	BL	→ A-25	-
Brake (Cable exiting right)	BR	→ A-25	-
Power-saving	LA	→ A-32	-
Reversed-home	NM	→ A-33	-
Slider Roller	SR	→ A-36	-

Actuator Specifications

Item	Description
Drive System	Ball screw Ø10mm C10 grade
Positioning Repeatability	±0.02mm
Lost Motion	0.1mm or less
Base	Material: Special alloy steel
Allowable Static Moment	Ma: 38.3 N·m Mb: 54.7 N·m Mc: 81.0 N·m
Allowable Dynamic Moment (*)	Ma: 8.9 N·m Mb: 12.7 N·m Mc: 18.6 N·m
Overhang Load Length	Ma direction: 220mm or less Mb-Mc direction: 220mm or less
Ambient Operating Temp./Humidity	0~40°C, 85% RH or less (non-condensing)

(*) Based on 5,000km travel life.

Directions of Allowable Load Moments

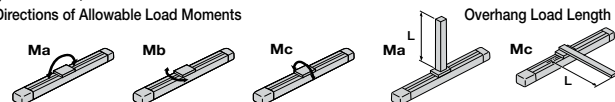

Dimensions

CAD drawings can be downloaded from IAI website. www.intelligentactuator.com

For Special Orders P. A-9

2D CAD

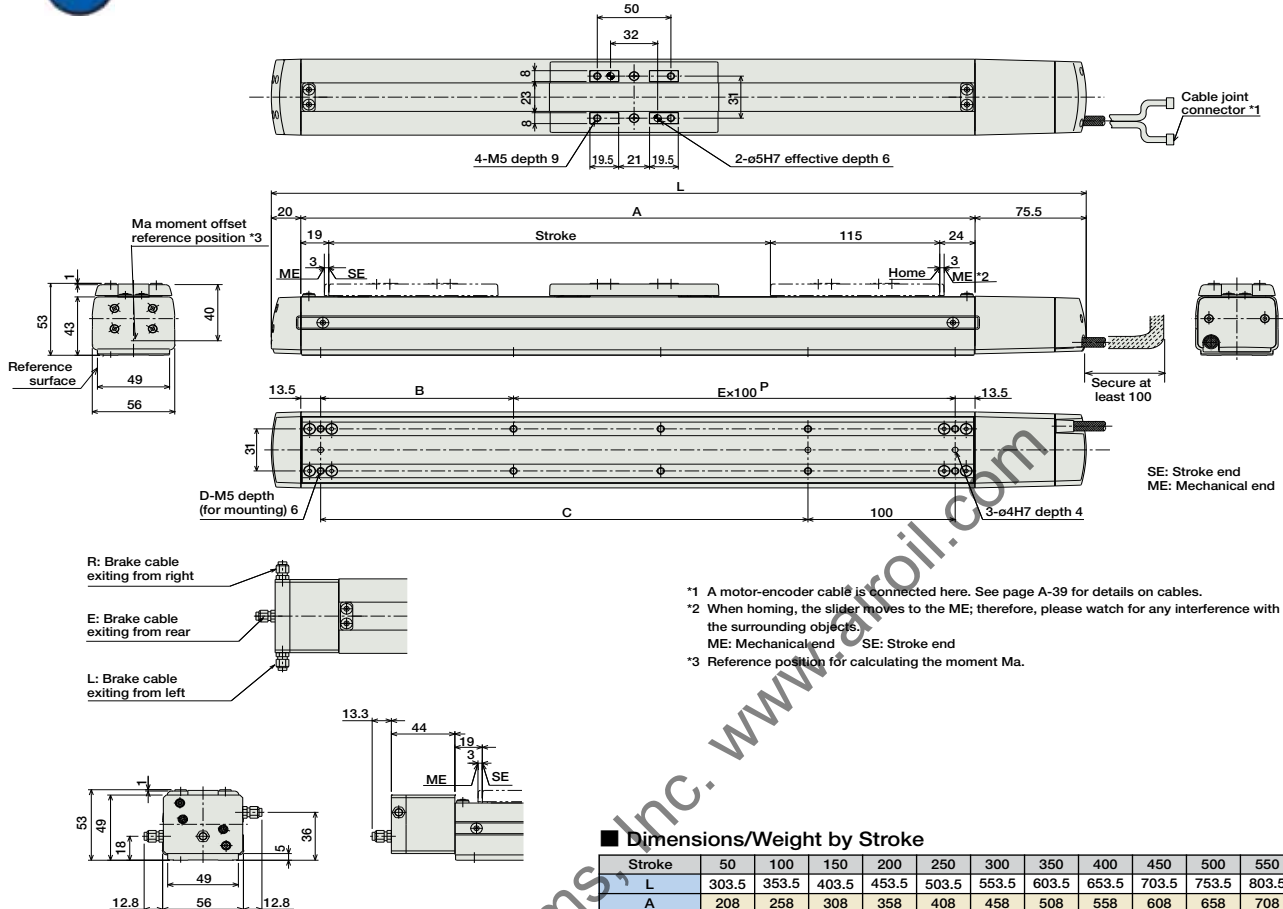

- *1 A motor-encoder cable is connected here. See page A-39 for details on cables.
- *2 When homing, the slider moves to the ME; therefore, please watch for any interference with the surrounding objects.
- *3 Reference position for calculating the moment Ma.

■ Dimensions/Weight by Stroke

Stroke	50	100	150	200	250	300	350	400	450	500	550	600
L	303.5	353.5	403.5	453.5	503.5	553.5	603.5	653.5	703.5	753.5	803.5	853.5
A	208	258	308	358	408	458	508	558	608	658	708	758
B	81	131	181	231	281	331	381	431	481	531	581	631
C	81	131	181	231	281	331	381	431	481	531	581	631
D	6	6	8	8	10	10	12	12	14	14	16	16
E	1	1	2	2	3	3	4	4	5	5	6	6
Weight (kg)	2.4	2.6	2.8	3.0	3.2	3.4	3.6	3.8	4.0	4.2	4.4	4.7

* Adding a brake will increase the actuator's overall length (L) by 24mm (37.3mm with the cable coming out from the end), and its weight by 0.3kg.

② Compatible Controllers

The RCA series actuators can operate with the controllers below. Select the controller according to your usage.

Name	External View	Model	Description	Max. Positioning Points	Input Voltage	Power Supply Capacity	Standard Price	See Page
Solenoid Valve Type		AMEC-C-30I②-NP-2-1	Easy-to-use controller, even for beginners	3 points	AC100V	2.4A rated	-	→ P477
		ASEP-C-30I②-NP-2-0	Operable with same signal as solenoid valve. Supports both single and double solenoid types. No homing necessary with simple absolute type.					
Splash-Proof Solenoid Valve Type		ASEP-CW-30I②-NP-2-0						
Positioner Type		ACON-C-30I②-NP-2-0	Positioning is possible for up to 512 points	512 points	DC24V	(Standard) 1.3A rated 4.4A max.	-	→ P535
Safety-Compliant Positioner Type		ACON-CG-30I②-NP-2-0						
Pulse Train Input Type (Differential Line Driver)		ACON-PL-30I②-NP-2-0	Pulse train input type with differential line driver support	(-)	DC24V	(Power-saving) 1.3A rated 2.2A max.	-	→ P535
Pulse Train Input Type (Open Collector)		ACON-PO-30I②-NP-2-0	Pulse train input type with open collector support					
Serial Communication Type		ACON-SE-30I②-N-0-0	Dedicated to serial communication	64 points				
Field Network Type		RACON-30②	Dedicated to field network	768 points				→ P503
Program Control Type		ASEL-C-1-30I②-NP-2-0	Programmed operation is possible Can operate up to 2 axes	1500 points				→ P567

* This is for the single-axis ASEL.
* ② is a placeholder for the code "LA" when the power-saving option is specified.

- Slider Type
- Mini
- Standard
- Controllers Integrated
- Rod Type
- Mini
- Standard
- Controllers Integrated
- Table/Arm/Flat Type
- Mini
- Standard
- Gripper/Rotary Type
- Linear Servo Type
- Cleanroom Type
- Splash-Proof
- Controllers
- PMEC/AMEC
- PSEP/ASEP
- ROBO NET
- ERC2
- PCON
- ACON
- SCON
- PSEL
- ASEL
- SSEL
- XSEL
- Pulse Motor
- Servo Motor (24V)
- Servo Motor (200V)
- Linear Servo Motor

RCA-SA4R

ROBO Cylinder Slider Type 40mm Width 24V Servo Motor Side-Mounted Motor

■ Configuration: **RCA** — **SA4R** — — **20** — — — — —

Series — Type — Encoder — Motor — Lead — Stroke — Compatible Controllers — Cable Length — Option

I: Incremental
A: Absolute
* Absolute encoder models can only use ASEL.
When the actuator is used with the simple absolute encoder, the model is considered an incremental model.

20: 20W Servo motor

10: 10mm
5: 5mm
2.5: 2.5mm

50: 50mm
400: 400mm (50mm pitch increments)

A1: ACON
RACON
ASEL
A3: AMEC
ASEP

N : None
P : 1m
S : 3m
M : 5m
X : Custom Length
R : Robot Cable

See Options below
* Be sure to specify which side the motor is to be mounted (ML/MR).

* See page Pre-35 for explanation of each code that makes up the configuration name.

Power-saving



Technical References P. A-5

POINT
Notes on Selection

(1) When the stroke increases, the maximum speed will drop to prevent the ball screw from reaching the critical rotational speed. Use the actuator specification table below to check the maximum speed at the stroke you desire.

(2) The load capacity is based on operation at an acceleration of 0.3G (0.2G for the 2.5mm-lead model, or when used vertically). These values are the upper limits for the acceleration.

Pictured: Left-mounted motor model (ML).

Actuator Specifications						
■ Lead and Load Capacity						
Model	Motor Output (W)	Lead (mm)	Max. Load Capacity		Rated Thrust (N)	
RCA-SA4R-①-20-10-②-③-④-⑤	20	10	Horizontal (kg)	Vertical (kg)	19.6	
RCA-SA4R-①-20-5-②-③-④-⑤		5	6	2.5		39.2
RCA-SA4R-①-20-2.5-②-③-④-⑤		2.5	8	4.5		78.4

■ Stroke and Maximum Speed		
Stroke Lead	50 ~ 400 (50mm increments)	Stroke (mm)
10	665	50 ~ 400 (50mm increments)
5	330	
2.5	165	

Legend ① Encoder ② Stroke ③ Compatible controller ④ Cable length ⑤ Options (Unit: mm/s)

Encoder & Stroke List		
② Stroke (mm)	Standard Price	
	① Encoder Type	
	Incremental	Absolute
	I	A
50	-	-
100	-	-
150	-	-
200	-	-
250	-	-
300	-	-
350	-	-
400	-	-

④ Cable List		
Type	Cable Symbol	Standard Price
Standard	P (1m)	—
	S (3m)	—
	M (5m)	—
Special Lengths	X06 (6m) ~ X10 (10m)	—
	X11 (11m) ~ X15 (15m)	—
	X16 (16m) ~ X20 (20m)	—
	R01 (1m) ~ R03 (3m)	—
Robot Cable	R04 (4m) ~ R05 (5m)	—
	R06 (6m) ~ R10 (10m)	—
	R11 (11m) ~ R15 (15m)	—
	R16 (16m) ~ R20 (20m)	—

* See page A-39 for cables for maintenance.

⑤ Option List			
Name	Option Code	See Page	Standard Price
Brake	B	→ A-25	—
Home sensor	HS	→ A-32	—
Power-saving	LA	→ A-32	—
Reversed-home	NM	→ A-33	—
Left-Mounted Motor (Standard)	ML	→ A-33	—
Right-Mounted Motor	MR	→ A-33	—
Slider Roller	SR	→ A-36	—
Slider spacer	SS	→ A-36	—

Actuator Specifications	
Item	Description
Drive System	Ball screw ø8mm C10 grade
Positioning Repeatability	±0.02mm
Lost Motion	0.1mm or less
Base	Material: Aluminum (white alumite treated)
Allowable Static Moment	Ma: 6.9N·m Mb: 9.9N·m Mc: 17.0N·m
Allowable Dynamic Moment (*)	Ma: 2.7N·m Mb: 3.9N·m Mc: 6.8N·m
Overhang Load Length	Ma direction: 120mm or less Mb-Mc direction: 120mm or less
Ambient Operating Temp./Humidity	0~40°C, 85%RH or less (Non-condensing)

(*) Based on 5,000km travel life.

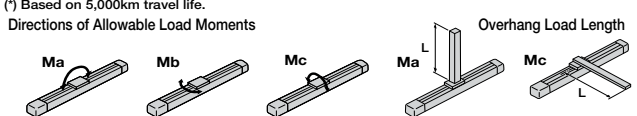

Dimensions

CAD drawings can be downloaded from IAI website. www.intelligentactuator.com

For Special Orders P. A-9

2D CAD

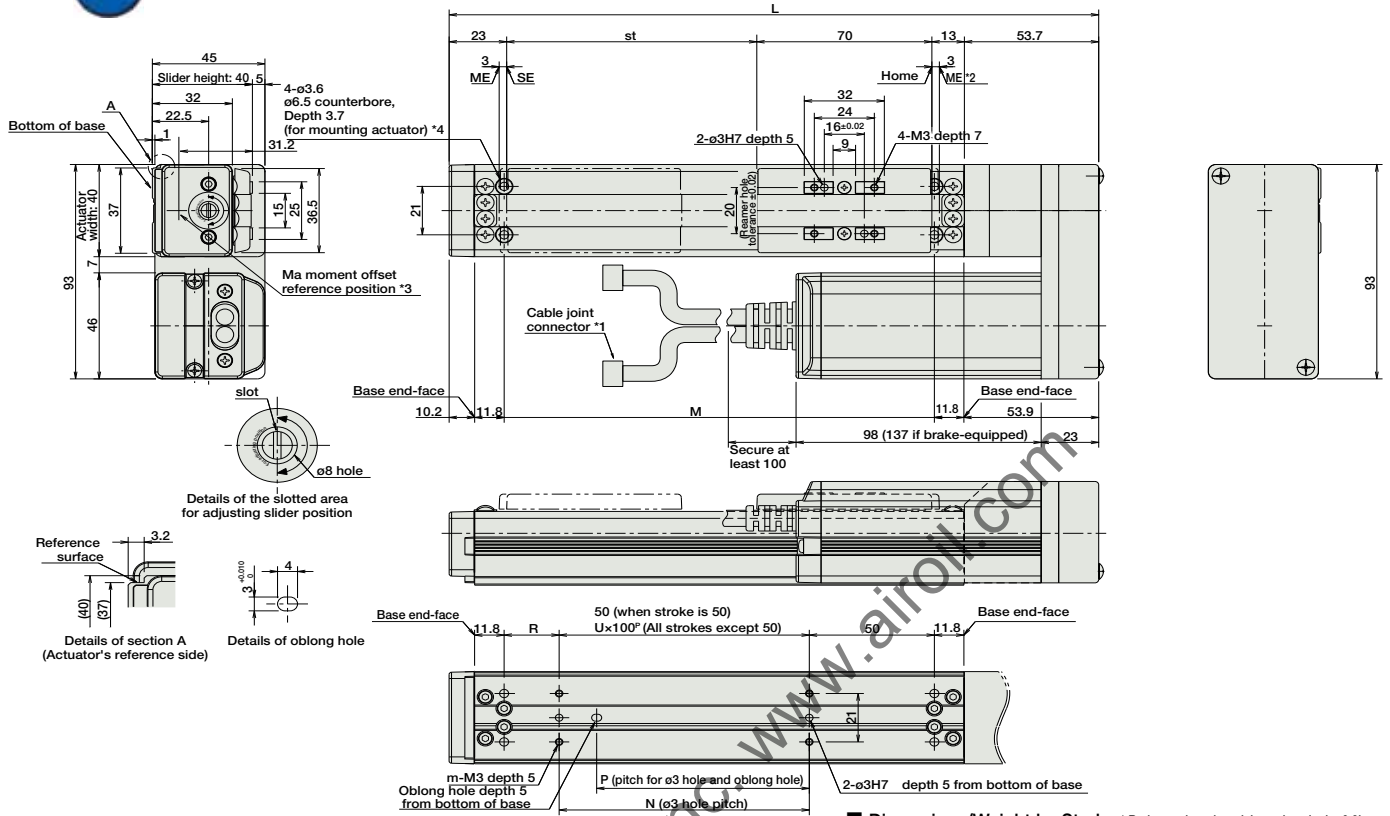

- *1 A motor-encoder cable is connected here. See page A-39 for details on cables.
- *2 When homing, the slider moves to the ME; therefore, please watch for any interference with the surrounding objects. ME: Mechanical end SE: Stroke end
- *3 Reference position for calculating the moment Ma.
- *4 If the actuator is secured using only the mounting holes provided on the top surface of the base, the base may twist to cause abnormal sliding of the slider, or may produce abnormal noise. Therefore, when using the mounting holes on the top surface of the base, keep the stroke at 200mm or less.

③ Compatible Controllers

The RCA series actuators can operate with the controllers below. Select the controller according to your usage.

Name	External View	Model	Description	Max. Positioning Points	Input Voltage	Power Supply Capacity	Standard Price	See Page
Solenoid Valve Type		AMEC-C-20I②-NP-2-1	Easy-to-use controller, even for beginners	3 points	AC100V	2.4A rated	-	→ P477
		ASEP-C-20I②-NP-2-0	Operable with same signal as solenoid valve. Supports both single and double solenoid types. No homing necessary with simple absolute type.					
Splash-Proof Solenoid Valve Type		ASEP-CW-20I②-NP-2-0						
Positioner Type		ACON-C-20I②-NP-2-0	Positioning is possible for up to 512 points	512 points	DC24V	(Standard) 1.3A rated 4.4A max.	-	
Safety-Compliant Positioner Type		ACON-CG-20I②-NP-2-0						
Pulse Train Input Type (Differential Line Driver)		ACON-PL-20I②-NP-2-0	Pulse train input type with differential line driver support	(-)	DC24V	(Power-saving) 1.3A rated 2.5A max.	-	→ P535
Pulse Train Input Type (Open Collector)		ACON-PO-20I②-NP-2-0	Pulse train input type with open collector support					
Serial Communication Type		ACON-SE-20I②-N-0-0	Dedicated to serial communication	64 points				
Field Network Type		RACON-20②	Dedicated to field network	768 points				→ P503
Program Control Type		ASEL-C-1-20①②-NP-2-0	Programmed operation is possible. Can operate up to 2 axes	1500 points				→ P567

* This is for the single-axis ASEL.
 * ① is a placeholder for the encoder type (I: incremental, A: absolute).
 * ② is a placeholder for the code "HA" or "LA", when the high-acceleration/deceleration option or the energy-saving option is selected.

RCA-SA5R

ROBO Cylinder Slider Type 52mm Width 24V Servo Motor Side-Mounted Motor

■ Configuration: **RCA** — **SA5R** — — **20** — — — — —

Series — Type — Encoder — Motor — Lead — Stroke — Compatible Controllers — Cable Length — Option

I: Incremental
A: Absolute
* Absolute encoder models can only use ASEL.
When the actuator is used with the simple absolute encoder, the model is considered an incremental model.

20: 20W Servo motor

12: 12mm
6: 6mm
3: 3mm

50: 50mm
500: 500mm (50mm pitch increments)

A1: ACON
RACON
ASEL
A3: AMEC
ASEP

N: None
P: 1m
S: 3m
M: 5m
X : Custom Length
R : Robot Cable

See Options below
* Be sure to specify which side the motor is to be mounted (ML/MR).

* See page Pre-35 for explanation of each code that makes up the configuration name.

Power-saving

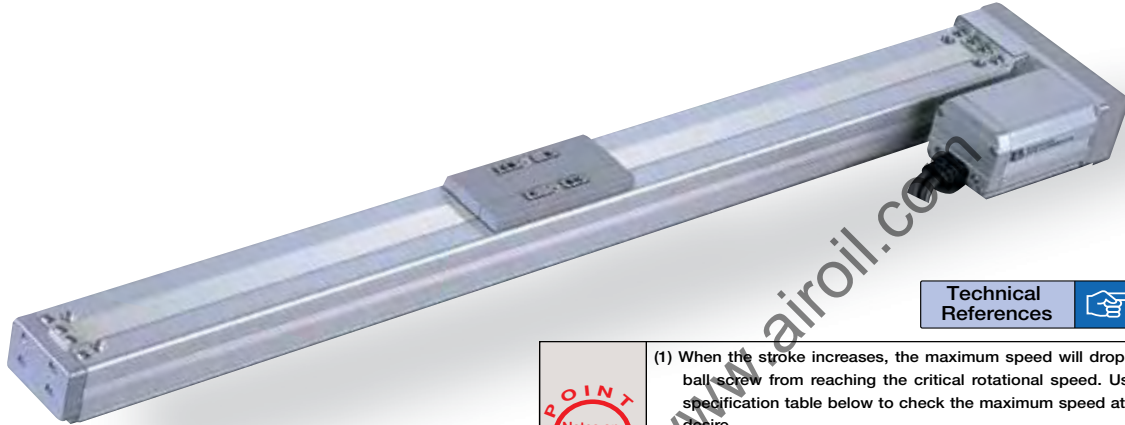

Technical References P. A-5

POINT
Notes on Selection

(1) When the stroke increases, the maximum speed will drop to prevent the ball screw from reaching the critical rotational speed. Use the actuator specification table below to check the maximum speed at the stroke you desire.

(2) The load capacity is based on operation at an acceleration of 0.3G (0.2G for the 3mm-lead model). These values are the upper limits for the acceleration.

Pictured: Left-mounted motor model (ML).

Actuator Specifications

Lead and Load Capacity

Model	Motor Output (W)	Lead (mm)	Max. Load Capacity Horizontal (kg) / Vertical (kg)	Rated Thrust (N)	Stroke (mm)
RCA-SA5R-①-20-12-②-③-④-⑤	20	12	4 / 1	16.7	50 ~ 500 (50mm increments)
RCA-SA5R-①-20-6-②-③-④-⑤	20	6	8 / 2	33.3	
RCA-SA5R-①-20-3-②-③-④-⑤	20	3	12 / 4	65.7	

Stroke and Maximum Speed

Stroke Lead	50 ~ 450 (50mm increments)	500 (mm)
12	800	760
6	400	380
3	200	190

Legend ① Encoder ② Stroke ③ Compatible controller ④ Cable length ⑤ Options (Unit: mm/s)

Encoder & Stroke List

② Stroke (mm)	Standard Price	
	① Encoder Type	
	Incremental	Absolute
50	-	-
100	-	-
150	-	-
200	-	-
250	-	-
300	-	-
350	-	-
400	-	-
450	-	-
500	-	-

④ Cable List

Type	Cable Symbol	Standard Price
Standard	P (1m)	—
	S (3m)	—
	M (5m)	—
Special Lengths	X06 (6m) ~ X10 (10m)	—
	X11 (11m) ~ X15 (15m)	—
	X16 (16m) ~ X20 (20m)	—
	R01 (1m) ~ R03 (3m)	—
Robot Cable	R04 (4m) ~ R05 (5m)	—
	R06 (6m) ~ R10 (10m)	—
	R11 (11m) ~ R15 (15m)	—
	R16 (16m) ~ R20 (20m)	—

* See page A-39 for cables for maintenance.

⑤ Option List

Name	Option Code	See Page	Standard Price
Brake	B	→ A-25	—
Home sensor	HS	→ A-32	—
Power-saving	LA	→ A-32	—
Reversed-home	NM	→ A-33	—
Left-Mounted Motor (Standard)	ML	→ A-33	—
Right-Mounted Motor	MR	→ A-33	—
Slider Roller	SR	→ A-36	—

Actuator Specifications

Item	Description
Drive System	Ball screw ø10mm C10 grade
Positioning Repeatability	±0.02mm
Lost Motion	0.1mm or less
Base	Material: Aluminum (white alumite treated)
Allowable Static Moment	Ma: 18.6N·m Mb: 26.6N·m Mc: 47.5N·m
Allowable Dynamic Moment (*)	Ma: 4.9N·m Mb: 6.8N·m Mc: 11.7N·m
Overhang Load Length	Ma direction: 150mm or less Mb-Mc direction: 150mm or less
Ambient Operating Temp./Humidity	0~40°C, 85%RH or less (Non-condensing)

(*) Based on 5,000km travel life.

Directions of Allowable Load Moments

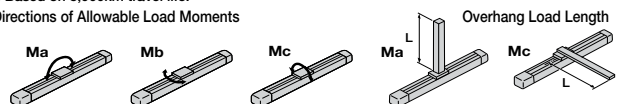

Dimensions

CAD drawings can be downloaded from IAI website. www.intelligentactuator.com

For Special Orders P. A-9

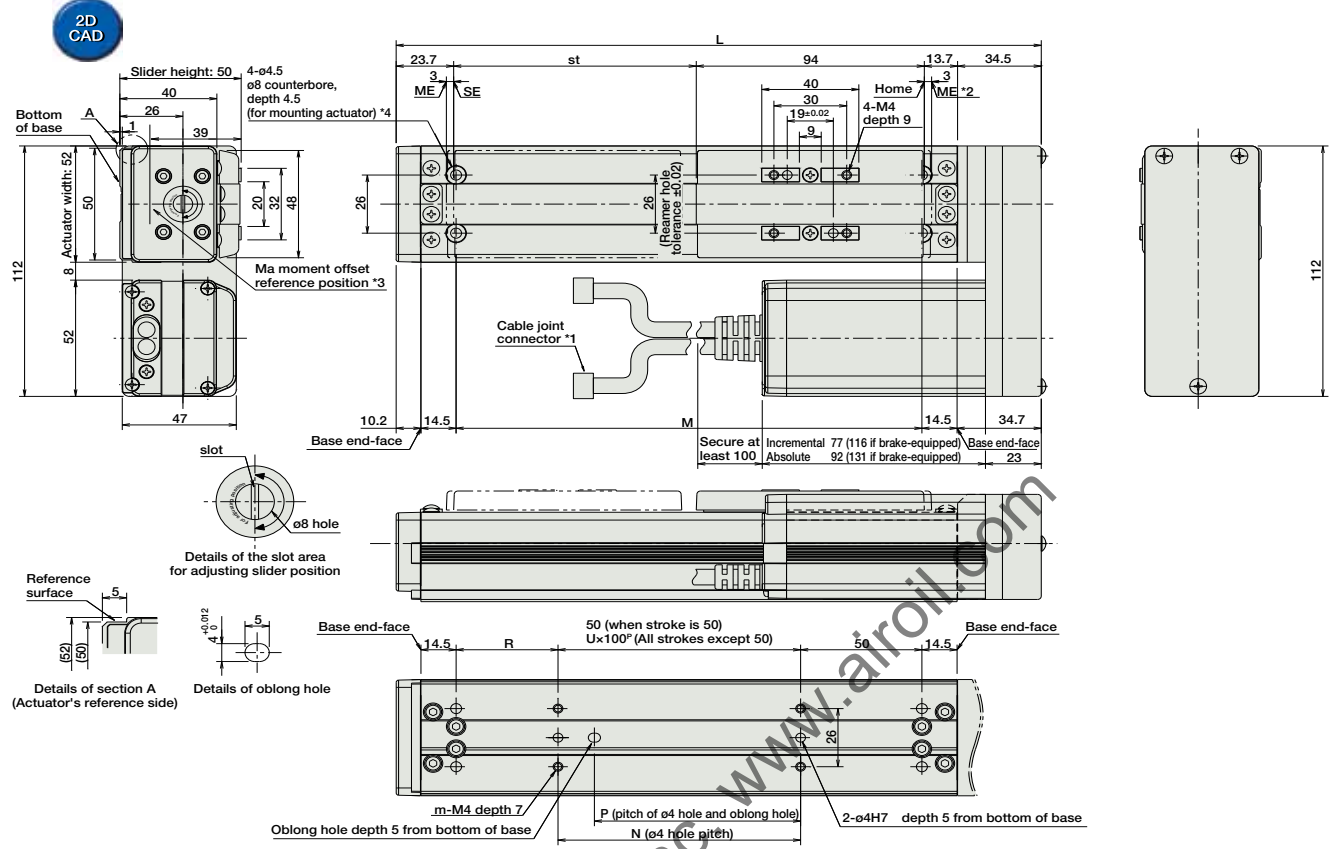

- *1 A motor-encoder cable is connected here. See page A-39 for details on cables.
- *2 When homing, the slider moves to the ME; therefore, please watch for any interference with the surrounding objects.
ME: Mechanical end SE: Stroke end
- *3 Reference position for calculating the moment Ma.
- *4 If the actuator is secured using only the mounting holes provided on the top surface of the base, the base may twist to cause abnormal sliding of the slider, or may produce abnormal noise. Therefore, when using the mounting holes on the top surface of the base, keep the stroke at 300mm or less.

■ Dimensions/Weight by Stroke * Brake-equipped models are heavier by 0.3kg.

Stroke	50	100	150	200	250	300	350	400	450	500
L	215.9	265.9	315.9	365.9	415.9	465.9	515.9	565.9	615.9	665.9
M	142	192	242	292	342	392	442	492	542	592
N	50	100	100	200	200	300	300	400	400	500
P	35	85	85	185	185	285	285	385	385	485
R	42	42	92	42	92	42	92	42	92	42
U	-	1	1	2	2	3	3	4	4	5
m	4	4	4	6	6	8	8	10	10	12
Weight (kg)	1.5	1.6	1.7	1.8	1.9	2.0	2.1	2.2	2.3	2.4

③ Compatible Controllers

The RCA series actuators can operate with the controllers below. Select the controller according to your usage.

Name	External View	Model	Description	Max. Positioning Points	Input Voltage	Power Supply Capacity	Standard Price	See Page
Solenoid Valve Type		AMEC-C-20I②-NP-2-1	Easy-to-use controller, even for beginners	3 points	AC100V	2.4A rated	-	→ P477
		ASEP-C-20I②-NP-2-0	Operable with same signal as solenoid valve. Supports both single and double solenoid types. No homing necessary with simple absolute type.					
Splash-Proof Solenoid Valve Type		ASEP-CW-20I②-NP-2-0						
Positioner Type		ACON-C-20I②-NP-2-0	Positioning is possible for up to 512 points	512 points	DC24V	(Standard) 1.3A rated 4.4A max.	-	
Safety-Compliant Positioner Type		ACON-CG-20I②-NP-2-0						
Pulse Train Input Type (Differential Line Driver)		ACON-PL-20I②-NP-2-0	Pulse train input type with differential line driver support	(-)	DC24V	(Power-saving) 1.3A rated 2.5A max.	-	→ P535
Pulse Train Input Type (Open Collector)		ACON-PO-20I②-NP-2-0	Pulse train input type with open collector support					
Serial Communication Type		ACON-SE-20I②-N-0-0	Dedicated to serial communication	64 points				
Field Network Type		RACON-20②	Dedicated to field network	768 points				→ P503
Program Control Type		ASEL-C-1-20①②-NP-2-0	Programmed operation is possible Can operate up to 2 axes	1500 points				→ P567

* This is for the single-axis ASEL.
 * ① is a placeholder for the encoder type (I: incremental, A: absolute).
 * ② is a placeholder for the code "HA" or "LA", when the high-acceleration/deceleration option or the energy-saving option is selected.

- Slider Type
- Mini
- Standard
- Controllers Integrated
- Rod Type
- Mini
- Standard
- Controllers Integrated
- Table/Arm/Flat Type
- Mini
- Standard
- Gripper/Rotary Type
- Linear Servo Type
- Cleanroom Type
- Splash-Proof
- Controllers
- PMEC/AMEC
- PSEP/ASEP
- ROBO NET
- ERC2
- PCON
- ACON
- SCON
- PSEL
- ASEL
- SSEL
- XSEL
- Pulse Motor
- Servo Motor (24V)
- Servo Motor (200V)
- Linear Servo Motor

RCA-SA6R

ROBO Cylinder Slider Type 58mm Width 24V Servo Motor Side-Mounted Motor

■ Configuration: **RCA** — **SA6R** — — **30** — — — —

Series — Type — Encoder — Motor — Lead — Stroke — Compatible Controllers — Cable Length — Option

I: Incremental 30: 30W Servo motor
 A: Absolute
* Absolute encoder models can only use ASEL.
 When the actuator is used with the simple absolute encoder, the model is considered an incremental model.

12: 12mm 50: 50mm
 6: 6mm
 3: 3mm 600: 600mm (50mm pitch increments)

A1: ACON
 RACON
 ASEL
 A3: AMEC
 ASEP

N : None
 P : 1m
 S : 3m
 M : 5m
 X : Custom Length
 R : Robot Cable

See Options below
 * Be sure to specify which side the motor is to be mounted (ML/MR).

* See page Pre-35 for explanation of each code that makes up the configuration name.

Power-saving

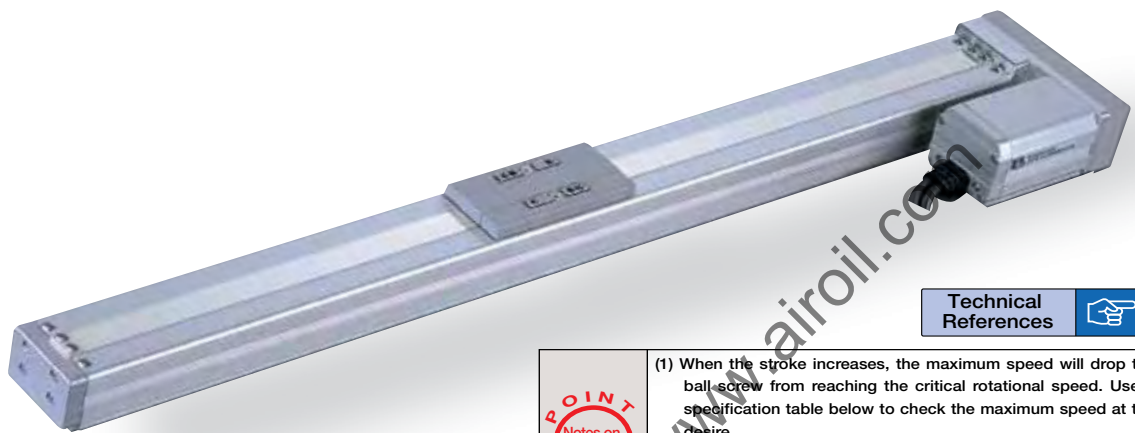

Technical References P. A-5

POINT
Notes on Selection

(1) When the stroke increases, the maximum speed will drop to prevent the ball screw from reaching the critical rotational speed. Use the actuator specification table below to check the maximum speed at the stroke you desire.

(2) The load capacity is based on operation at an acceleration of 0.3G (0.2G for the 3mm-lead model). These values are the upper limits for the acceleration.

Pictured: Left-mounted motor model (ML).

Actuator Specifications					
■ Lead and Load Capacity					
Model	Motor Output (W)	Lead (mm)	Max. Load Capacity Horizontal (kg)/Vertical (kg)	Rated Thrust (N)	Stroke (mm)
RCA-SA6R-①-30-12-②-③-④-⑤	30	12	6 / 1.5	24.2	50 ~ 600 (50mm increments)
RCA-SA6R-①-30-6-②-③-④-⑤		6	12 / 3	48.4	
RCA-SA6R-①-30-3-②-③-④-⑤		3	18 / 6	96.8	

■ Stroke and Maximum Speed					
Stroke Lead	50 ~ 450 (50mm increments)	500 (mm)	550 (mm)	600 (mm)	
12	800	760	640	540	
6	400	380	320	270	
3	200	190	160	135	

Legend ① Encoder ② Stroke ③ Compatible controller ④ Cable length ⑤ Options (Unit: mm/s)

Encoder & Stroke List		
② Stroke (mm)	Standard Price	
	① Encoder Type	
	Incremental	Absolute
	I	A
50	-	-
100	-	-
150	-	-
200	-	-
250	-	-
300	-	-
350	-	-
400	-	-
450	-	-
500	-	-
550	-	-
600	-	-

④ Cable List		
Type	Cable Symbol	Standard Price
Standard	P (1m)	—
	S (3m)	—
	M (5m)	—
Special Lengths	X06 (6m) ~ X10 (10m)	—
	X11 (11m) ~ X15 (15m)	—
	X16 (16m) ~ X20 (20m)	—
	R01 (1m) ~ R03 (3m)	—
Robot Cable	R04 (4m) ~ R05 (5m)	—
	R06 (6m) ~ R10 (10m)	—
	R11 (11m) ~ R15 (15m)	—
	R16 (16m) ~ R20 (20m)	—

* See page A-39 for cables for maintenance.

⑤ Option List			
Name	Option Code	See Page	Standard Price
Brake	B	→ A-25	—
Home sensor	HS	→ A-32	—
Power-saving	LA	→ A-32	—
Reversed-home	NM	→ A-33	—
Left-Mounted Motor (Standard)	ML	→ A-33	—
Right-Mounted Motor	MR	→ A-33	—
Slider Roller	SR	→ A-36	—

Actuator Specifications	
Item	Description
Drive System	Ball screw ø10mm C10 grade
Positioning Repeatability	±0.02mm
Lost Motion	0.1mm or less
Base	Material: Aluminum (white alumite treated)
Allowable Static Moment	Ma: 38.3N·m Mb: 54.7N·m Mc: 81.0N·m
Allowable Dynamic Moment (*)	Ma: 8.9 N·m Mb: 12.7 N·m Mc: 18.6 N·m
Overhang Load Length	Ma direction: 220mm or less Mb-Mc direction: 220mm or less
Ambient Operating Temp./Humidity	0~40°C, 85%RH or less (Non-condensing)

(*) Based on 5,000km travel life.

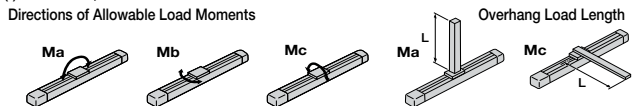

Dimensions

CAD drawings can be downloaded from IAI website. www.intelligentactuator.com

For Special Orders P. A-9

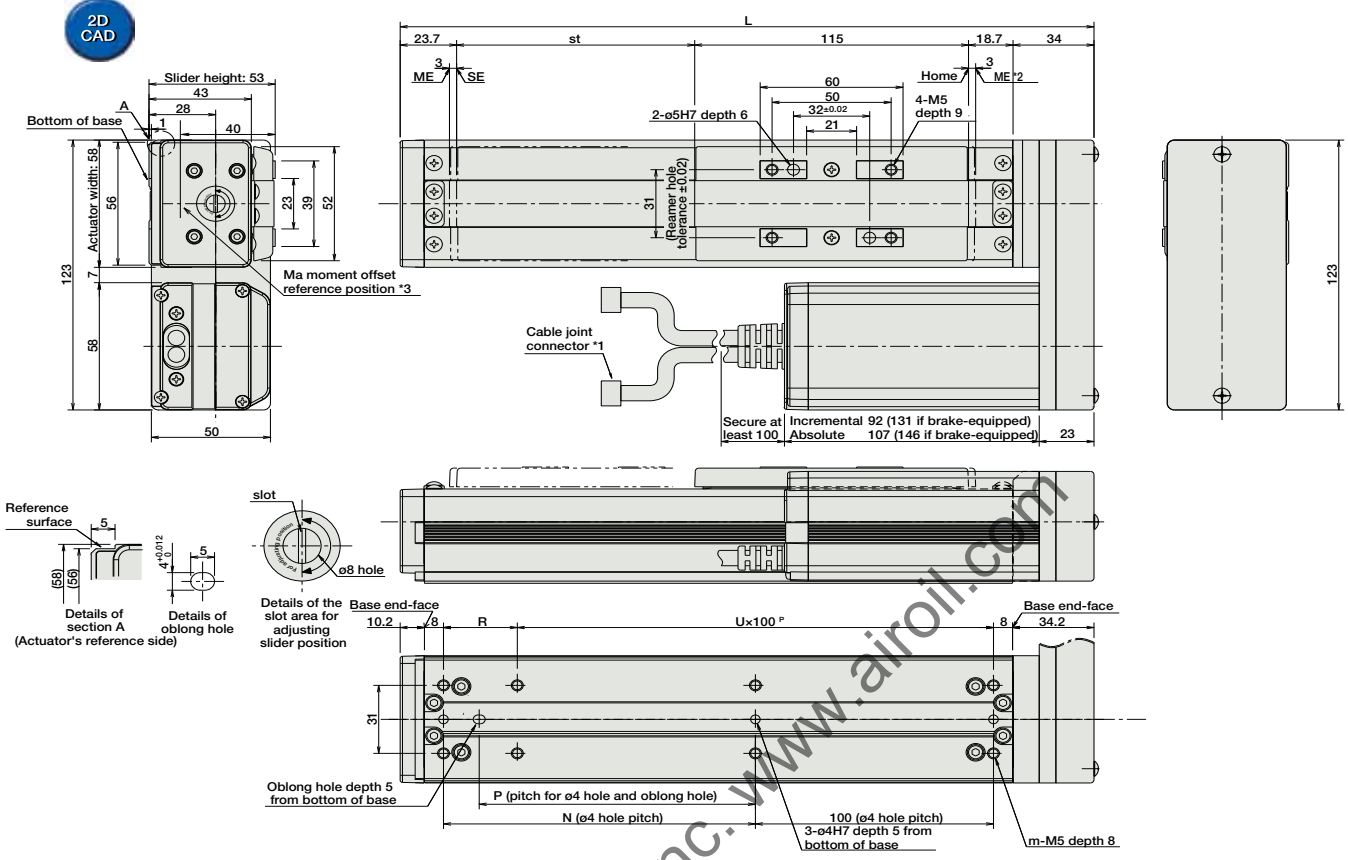

■ Dimensions/Weight by Stroke * Brake-equipped models are heavier by 0.3kg.

Stroke	50	100	150	200	250	300	350	400	450	500	550	600
L	241.4	291.4	341.4	391.4	441.4	491.4	541.4	591.4	641.4	691.4	741.4	791.4
N	81	131	181	231	281	331	381	431	481	531	581	631
P	66	116	166	216	266	316	366	416	466	516	566	616
R	81	31	81	31	81	31	81	31	81	31	81	31
U	1	2	2	3	3	4	4	5	5	6	6	7
m	6	8	8	10	10	12	12	14	14	16	16	18
Weight (kg)	1.7	1.9	2.1	2.3	2.5	2.7	2.9	3.1	3.3	3.5	3.7	3.9

*1 A motor-encoder cable is connected here. See page A-39 for details on cables.
 *2 When homing, the slider moves to the ME; therefore, please watch for any interference with the surrounding objects.
 ME: Mechanical end SE: Stroke end
 *3 Reference position for calculating the moment Ma.

③ Compatible Controllers

The RCA series actuators can operate with the controllers below. Select the controller according to your usage.

Name	External View	Model	Description	Max. Positioning Points	Input Voltage	Power Supply Capacity	Standard Price	See Page
Solenoid Valve Type		AMEC-C-30I②-NP-2-1	Easy-to-use controller, even for beginners	3 points	AC100V	2.4A rated	-	→ P477
		ASEP-C-30I②-NP-2-0	Operable with same signal as solenoid valve. Supports both single and double solenoid types. No homing necessary with simple absolute type.					
Splash-Proof Solenoid Valve Type		ASEP-CW-30I②-NP-2-0						→ P487
Positioner Type		ACON-C-30I②-NP-2-0	Positioning is possible for up to 512 points	512 points	DC24V	(Standard) 1.3A rated 4.4A max.	-	
Safety-Compliant Positioner Type		ACON-CG-30I②-NP-2-0						
Pulse Train Input Type (Differential Line Driver)		ACON-PL-30I②-NP-2-0	Pulse train input type with differential line driver support	(-)	DC24V	(Power-saving) 1.3A rated 2.2A max.	-	→ P535
Pulse Train Input Type (Open Collector)		ACON-PO-30I②-NP-2-0	Pulse train input type with open collector support					
Serial Communication Type		ACON-SE-30I②-N-0-0	Dedicated to serial communication	64 points				
Field Network Type		RACON-30②	Dedicated to field network	768 points				→ P503
Program Control Type		ASEL-C-1-30①②-NP-2-0	Programmed operation is possible Can operate up to 2 axes	1500 points				→ P567

* This is for the single-axis ASEL.
 * ① is a placeholder for the encoder type (I: incremental, A: absolute).
 * ② is a placeholder for the code "HA" or "LA", when the high-acceleration/deceleration option or the energy-saving option is selected.

RCS2-SA4C

ROBO Cylinder Slider Type 40mm Width 200V Servo Motor Side-Mounted Motor

■ Configuration: **RCS2** — **SA4C** — — **20** — — — — —

Series — Type — Encoder — Motor — Lead — Stroke — Compatible Controllers — Cable Length — Option

I : Incremental A:Absolute 20: 20W Servo motor 10:10mm 5: 5mm 2.5:2.5mm 50: 50mm 400:400mm (50mm pitch increments) T1: XSEL-J/K T2: SCON SSEL XSEL-P/Q N : None P : 1m S : 3m M : 5m X : Custom Length R : Robot Cable See Options below

* See page Pre-35 for explanation of each code that makes up the configuration name.

For High Acceleration/Deceleration

(excluding the 2.5-mm lead model)

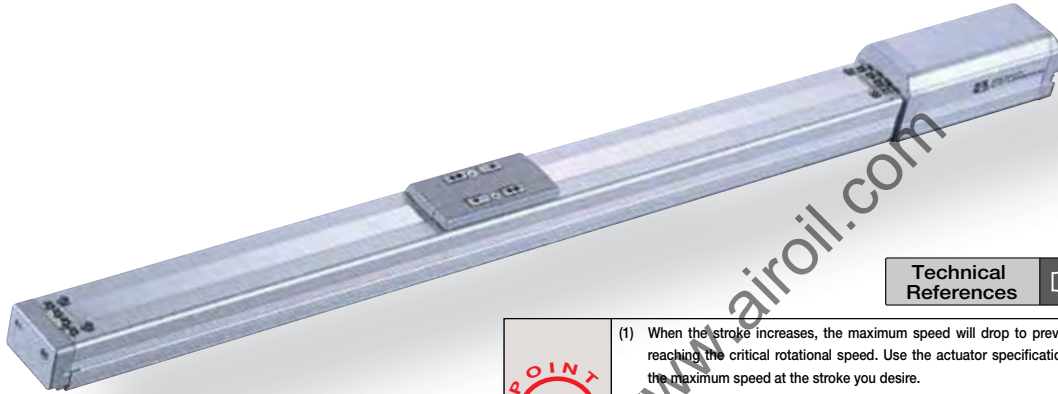

Technical References P. A-5

- POINT**
Notes on Selection
- (1) When the stroke increases, the maximum speed will drop to prevent the ball screw from reaching the critical rotational speed. Use the actuator specification table below to check the maximum speed at the stroke you desire.
 - (2) The load capacity is based on operation of the standard model at 0.3G (0.2G for 2.5mm-lead), and the high acceleration/deceleration model at 1G (excluding the 2.5mm-lead model). (Even when the acceleration/deceleration is dropped, the maximum load capacity values shown in the table below are the upper limits.)

Actuator Specifications

■ Lead and Load Capacity

Model	Motor Output (W)	Lead (mm)	Max. Load Capacity Horizontal (kg)	Max. Load Capacity Vertical (kg)	Rated Thrust (N)	Stroke (mm)
RCS2-SA4C-①-20-10-②-③-④-⑤	20	10	4	1	19.6	50~400 (50mm increments)
RCS2-SA4C-①-20-5-②-③-④-⑤		5	6	2.5	39.2	
RCS2-SA4C-①-20-2.5-②-③-④-⑤		2.5	8	4.5	78.4	

■ Stroke and Maximum Speed

Stroke Lead	50 ~ 400 (50mm increments)
10	665
5	330
2.5	165

Legend ① Encoder ② Stroke ③ Compatible controller ④ Cable length ⑤ Options (Unit: mm/s)

Encoder & Stroke List

② Stroke (mm)	Standard Price	
	① Encoder Type	
	Incremental	Absolute
50	I	A
100	-	-
150	-	-
200	-	-
250	-	-
300	-	-
350	-	-
400	-	-

④ Cable List

Type	Cable Symbol	Standard Price
Standard	P (1m)	—
	S (3m)	—
	M (5m)	—
Special Lengths	X06 (6m) ~ X10 (10m)	—
	X11 (11m) ~ X15 (15m)	—
	X16 (16m) ~ X20 (20m)	—
	R01 (1m) ~ R03 (3m)	—
Robot Cable	R04 (4m) ~ R05 (5m)	—
	R06 (6m) ~ R10 (10m)	—
	R11 (11m) ~ R15 (15m)	—
	R16 (16m) ~ R20 (20m)	—

* For cables for maintenance, see page A-39.

⑤ Option List

Name	Option Code	See Page	Standard Price
Brake	B	→ A-25	—
Foot bracket	FT	→ A-29	—
For High Acceleration/Deceleration	HA	→ A-32	—
Home sensor	HS	→ A-32	—
Reversed-home	NM	→ A-33	—
Slider Roller	SR	→ A-36	—
Slider spacer	SS	→ A-36	—

* The high-acceleration/deceleration option and the slider roller option cannot be used together.
* The 2.5mm-lead model cannot be used with the high-acceleration/deceleration option.

Actuator Specifications

Item	Description
Drive System	Ball screw Ø8mm C10 grade
Positioning Repeatability	±0.02mm
Lost Motion	0.1mm or less
Base	Material: Aluminum (white alumite treated)
Allowable Static Moment	Ma: 6.9N·m Mb: 9.9N·m Mc: 17.0N·m
Allowable Dynamic Moment (*)	Ma: 2.7N·m Mb: 3.9N·m Mc: 6.8N·m
Overhang Load Length	Ma direction: 120mm or less Mb-Mc direction: 120mm or less
Ambient Operating Temp./Humidity	0~40°C, 85% RH or less (Non-condensing)

(*) Based on 5,000km travel life.

Directions of Allowable Load Moments

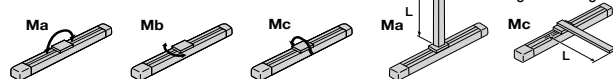

Dimensions

CAD drawings can be downloaded from IAI website. www.intelligentactuator.com

For Special Orders P. A-9



- *1 A motor-encoder cable is connected here. See page A-39 for details on cables.
- *2 When homing, the slider moves to the ME; therefore, please watch for any interference with the surrounding objects.
ME: Mechanical end SE: Stroke end
- *3 Reference position for calculating the moment Ma.
- *4 If the actuator is secured using only the mounting holes provided on the top surface of the base, the base may twist to cause abnormal sliding of the slider, or may produce abnormal noise. Therefore, when using the mounting holes on the top surface of the base, keep the stroke at 200mm or less.

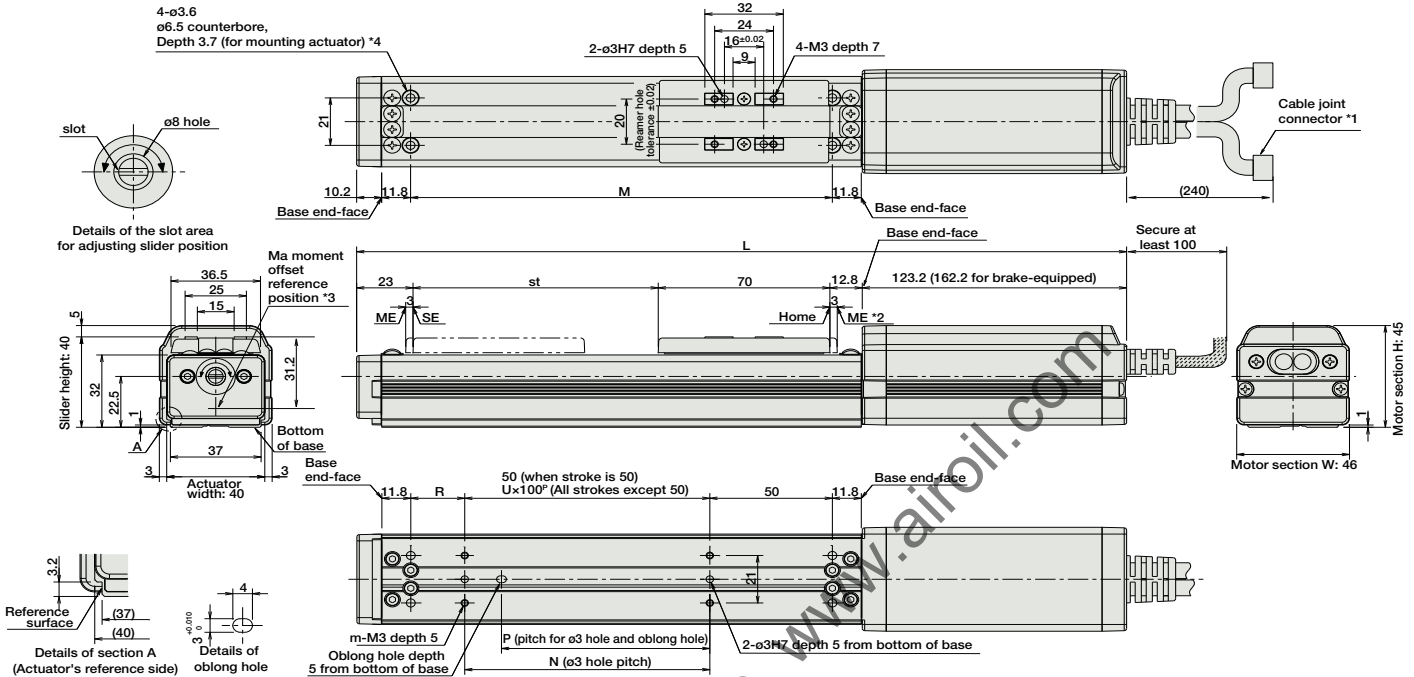

Dimensions/Weight by Stroke * Brake-equipped models are heavier by 0.3kg.

Stroke	50	100	150	200	250	300	350	400
L	No Brake	279	329	379	429	479	529	579
	With Brake	318	368	418	468	518	568	618
M	122	172	222	272	322	372	422	472
N	50	100	100	200	200	300	300	400
P	35	85	85	185	185	285	285	385
R	22	22	72	22	72	22	72	22
U	-	1	1	2	2	3	3	4
m	4	4	4	6	6	8	8	10
Weight (kg)	0.7	0.8	0.9	1	1.1	1.2	1.3	1.4

3 Compatible Controllers

The RCS2 series actuators can operate with the controllers below. Select the controller according to your usage.

Name	External View	Model	Description	Max. Positioning Points	Input Voltage	Power Supply Capacity	Standard Price	See Page
Positioner Mode		SCON-C-20①②-NP-2-③	Positioning is possible for up to 512 points	512 points	Single-Phase AC 100V Single-Phase AC 200V 3-Phase AC 200V (XSEL-P/Q only)	360VA max. * When operating a 150W single-axis model	-	→ P547
Solenoid Valve Mode			Operable with same controls as solenoid valve.	7 points				
Serial Communication Type			Dedicated to serial communication	64 points				
Pulse Train Input Control Type			Dedicated to Pulse Train Input	(-)				
Program Control 1-2 Axis Type		SSEL-C-1-20 ①②-NP-2-③	Programmed operation is possible Can operate up to 2 axes	20000 points			-	→ P577
Program Control 1-6 Axis Type		XSEL-④-1-20①②-N1-EEE-2-⑤	Programmed operation is possible Can operate up to 6 axes	20000 points			-	→ P587

* For SSEL and XSEL, only applicable to the single-axis model.
 * ① is a placeholder for the encoder type (I: incremental, A: absolute).
 * ② is a placeholder for the code "HA" when the high acceleration/deceleration option is specified.
 * ③ is a placeholder for the power supply voltage (1: single-phase 100V, 2: single phase 200V).
 * ④ is a placeholder for the XSEL type name (J, K, P, Q).
 * ⑤ is a placeholder for the power supply voltage type (1: 100V, 2: single-phase 200V, 3: 3-phase 200V).

- Slider Type
- Mini
- Standard
- Controllers Integrated
- Rod Type
- Mini
- Standard
- Controllers Integrated
- Table/Arm/Flat Type
- Mini
- Standard
- Gripper/Rotary Type
- Linear Servo Type
- Cleanroom Type
- Splash-Proof
- Controllers
- PMEC/AMEC
- PSEP/ASEP
- ROBO NET
- ERC2
- PCON
- ACON
- SCON
- PSEL
- ASEL
- SSEL
- XSEL
- Pulse Motor
- Servo Motor (24V)
- Servo Motor (200V)
- Linear Servo Motor

RCS2-SA5C

ROBO Cylinder Slider Type 52mm Width 200V Servo Motor Coupled

■ Configuration: **RCS2** — **SA5C** — — **20** — — — — —

Series — Type — Encoder — Motor — Lead — Stroke — Compatible Controllers — Cable Length — Option

I : Incremental
A : Absolute

20: 20W Servo motor

12: 12mm
6: 6mm
3: 3mm

50: 50mm
500: 500mm (50mm pitch increments)

T1: XSEL-J/K
T2: SCON
SSEL
XSEL-P/Q

N : None
P : 1m
S : 3m
M : 5m
X : Custom Length
R : Robot Cable

See Options below

* See page Pre-35 for explanation of each code that makes up the configuration name.

For High Acceleration/Deceleration

(excluding the 3-mm lead model)

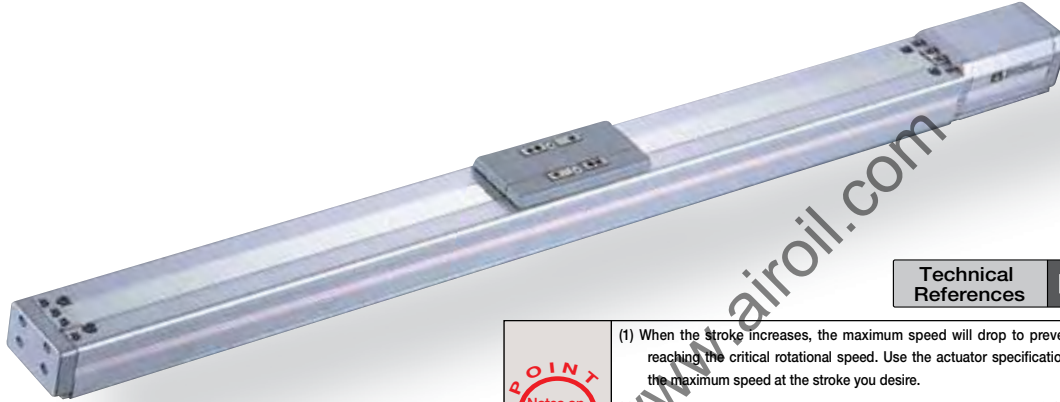

Technical References P. A-5

- POINT**
Notes on Selection
- (1) When the stroke increases, the maximum speed will drop to prevent the ball screw from reaching the critical rotational speed. Use the actuator specification table below to check the maximum speed at the stroke you desire.
 - (2) The lead capacity is based on operation of standard model at 0.3G (0.2G for 3mm-lead), and operation of the high acceleration/deceleration model at 0.8G (excluding the 3mm-lead model). (Even when the acceleration/deceleration is dropped, the maximum load capacity values shown in the table below are the upper limits.)

Actuator Specifications

■ Lead and Load Capacity

Model	Motor Output (W)	Lead (mm)	Max. Load Capacity		Rated Thrust (N)	Stroke (mm)
			Horizontal (kg)	Vertical (kg)		
RCS2-SA5C-①-20-12-②-③-④-⑤	20	12	4	1	16.7	50 ~ 500 (50mm increments)
RCS2-SA5C-①-20-6-②-③-④-⑤		6	8	2	33.3	
RCS2-SA5C-①-20-3-②-③-④-⑤		3	12	4	65.7	

■ Stroke and Maximum Speed

Stroke Lead	50 ~ 450 (50mm increments)	500 (mm)
	12	800
6	400	380
3	200	190

Legend ① Encoder ② Stroke ③ Compatible controller ④ Cable length ⑤ Options (Unit: mm/s)

Encoder & Stroke List

② Stroke (mm)	Standard Price	
	① Encoder Type	
	Incremental	Absolute
50	I	A
100	-	-
150	-	-
200	-	-
250	-	-
300	-	-
350	-	-
400	-	-
450	-	-
500	-	-

④ Cable List

Type	Cable Symbol	Standard Price
Standard	P (1m)	—
	S (3m)	—
	M (5m)	—
Special Lengths	X06 (6m) ~ X10 (10m)	—
	X11 (11m) ~ X15 (15m)	—
	X16 (16m) ~ X20 (20m)	—
	R01 (1m) ~ R03 (3m)	—
Robot Cable	R04 (4m) ~ R05 (5m)	—
	R06 (6m) ~ R10 (10m)	—
	R11 (11m) ~ R15 (15m)	—
	R16 (16m) ~ R20 (20m)	—

* For cables for maintenance, see page A-39.

⑤ Option List

Name	Option Code	See Page	Standard Price
Brake	B	→ A-25	—
Foot bracket	FT	→ A-29	—
For High Acceleration/Deceleration	HA	→ A-32	—
Home sensor	HS	→ A-32	—
Reversed-home	NM	→ A-33	—
Slider Roller	SR	→ A-36	—

* The high-acceleration/deceleration option and the slider roller option cannot be used together.
* The high acceleration/deceleration option cannot be used on the 3mm-lead model.

Actuator Specifications

Item	Description
Drive System	Ball screw Ø10mm C10 grade
Positioning Repeatability	±0.02mm
Lost Motion	0.1mm or less
Base	Material: Aluminum (white alumite treated)
Allowable Static Moment	Ma: 18.6N·m Mb: 26.6N·m Mc: 47.5N·m
Allowable Dynamic Moment (*)	Ma: 4.9N·m Mb: 6.8N·m Mc: 11.7N·m
Overhang Load Length	Ma direction: 150mm or less Mb-Mc direction: 150mm or less
Ambient Operating Temp./Humidity	0~40°C, 85% RH or less (Non-condensing)

(*) Based on 5,000km travel life.
Directions of Allowable Load Moments

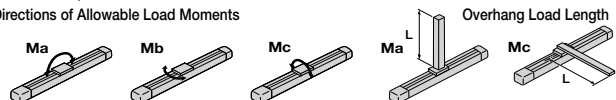

Dimensions

CAD drawings can be downloaded from IAI website. www.intelligentactuator.com

For Special Orders P. A-9



- *1 A motor-encoder cable is connected here. See page A-39 for details on cables.
- *2 When homing, the slider moves to the ME; therefore, please watch for any interference with the surrounding objects.
ME: Mechanical end SE: Stroke end
- *3 Reference position for calculating the moment Ma.

- *4 If the actuator is secured using only the mounting holes provided on the top surface of the base, the base may twist to cause abnormal sliding of the slider, or may produce abnormal noise. Therefore, when using the mounting holes on the top surface of the base, keep the stroke at 300mm or less.

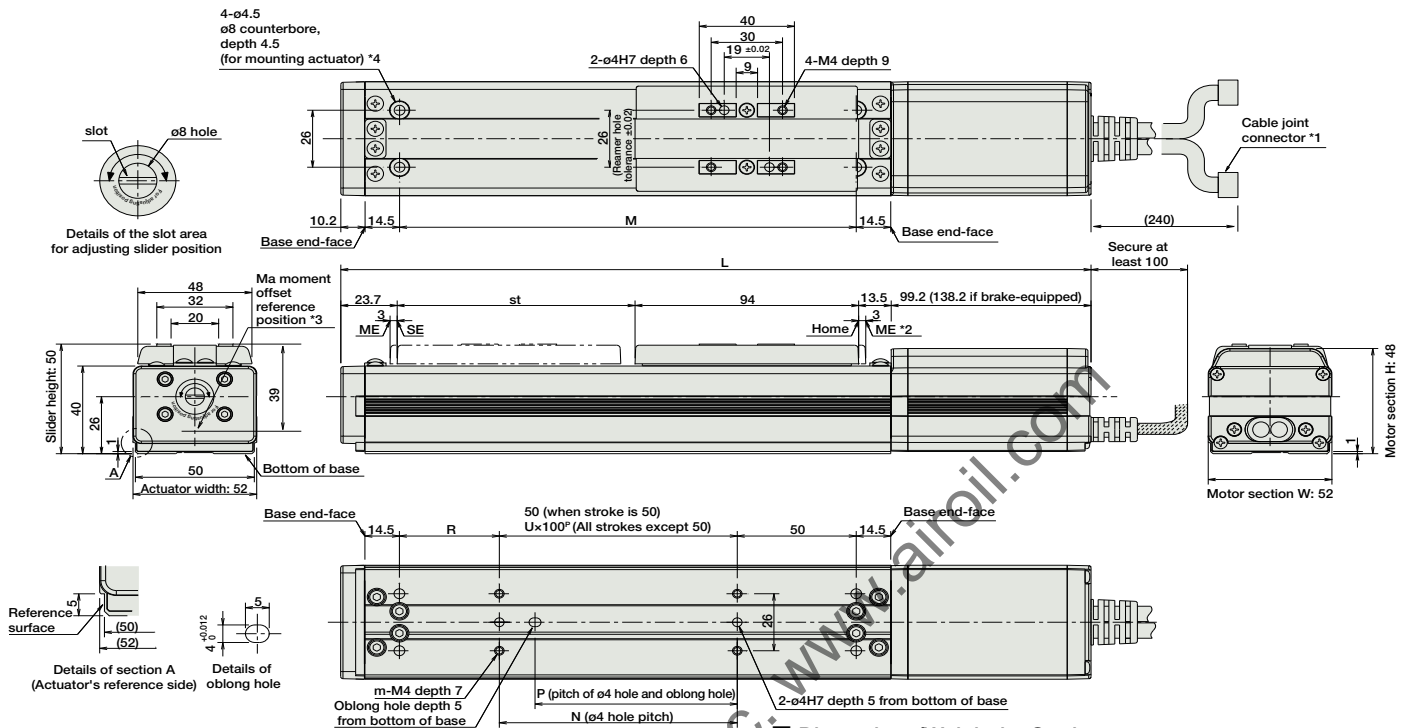

■ Dimensions/Weight by Stroke

* Brake-equipped models are heavier by 0.3kg.

Stroke	50	100	150	200	250	300	350	400	450	500	
L	No Brake	280.4	330.4	380.4	430.4	480.4	530.4	580.4	630.4	680.4	730.4
	With Brake	319.4	369.4	419.4	469.4	519.4	569.4	619.4	669.4	719.4	769.4
M	142	192	242	292	342	392	442	492	542	592	
N	50	100	100	200	200	300	300	400	400	500	
P	35	85	85	185	185	285	285	385	385	485	
R	42	42	92	42	92	42	92	42	92	42	
U	-	1	1	2	2	3	3	4	4	5	
m	4	4	4	6	6	8	8	10	10	12	
Weight (kg)	1.3	1.4	1.5	1.6	1.7	1.8	1.9	2	2.1	2.2	

③ Compatible Controllers

The RCS2 series actuators can operate with the controllers below. Select the controller according to your usage.

Name	External View	Model	Description	Max. Positioning Points	Input Voltage	Power Supply Capacity	Standard Price	See Page
Positioner Mode		SCON-C-20①②-NP-2-③	Positioning is possible for up to 512 points	512 points	Single-Phase AC 100V Single-Phase AC 200V 3-Phase AC 200V (XSEL-P/Q only)	360VA max. * When operating a 150W single-axis model	-	→ P547
Solenoid Valve Mode			Operable with same controls as solenoid valve.	7 points				
Serial Communication Type			Dedicated to serial communication	64 points				
Pulse Train Input Control Type			Dedicated to Pulse Train Input	(-)				
Program Control 1-2 Axis Type		SSEL-C-1-20①②-NP-2-③	Programmed operation is possible Can operate up to 2 axes	20000 points			-	→ P577
Program Control 1-6 Axis Type		XSEL-④-1-20①②-N1-EEE-2-⑤	Programmed operation is possible Can operate up to 6 axes	20000 points			-	→ P587

- * For SSEL and XSEL, only applicable to the single-axis model.
- * ① is a placeholder for the encoder type (I: incremental, A: absolute).
- * ② is a placeholder for the code "HA" when the high acceleration/deceleration option is specified.
- * ③ is a placeholder for the power supply voltage (1: single-phase 100V, 2: single phase 200V).
- * ④ is a placeholder for the XSEL type name (J, K, P, Q).
- * ⑤ is a placeholder for the power supply voltage type (1: 100V, 2: single-phase 200V, 3: 3-phase 200V).

- Slider Type
- Mini
- Standard
- Controllers Integrated
- Rod Type
- Mini
- Standard
- Controllers Integrated
- Table/Arm/Flat Type
- Mini
- Standard
- Gripper/Rotary Type
- Linear Servo Type
- Cleanroom Type
- Splash-Proof
- Controllers
- PMEC /AMEC
- PSEP /ASEP
- ROBO NET
- ERC2
- PCON
- ACON
- SCON
- PSEL
- ASEL
- SSEL
- XSEL
- Pulse Motor
- Servo Motor (24V)
- Servo Motor (200V)
- Linear Servo Motor

RCS2-SA6C ROBO Cylinder Slider Type 58mm Width 200V Servo Motor Coupled

■ Configuration: **RCS2** — **SA6C** — — **30** — — — — — —

Series — Type — Encoder — Motor — Lead — Stroke — Compatible Controllers — Cable Length — Option

I : Incremental
A : Absolute

30: 30W Servo motor

12: 12mm
6: 6mm
3: 3mm

50: 50mm
600: 600mm (50mm pitch increments)

T1: XSEL-J/K
T2: SCON
SSEL
XSEL-P/Q

N : None
P : 1m
S : 3m
M : 5m
X : Custom Length
R : Robot Cable

See Options below

* See page Pre-35 for explanation of each code that makes up the configuration name.

For High Acceleration/Deceleration

(excluding the 3-mm lead model)

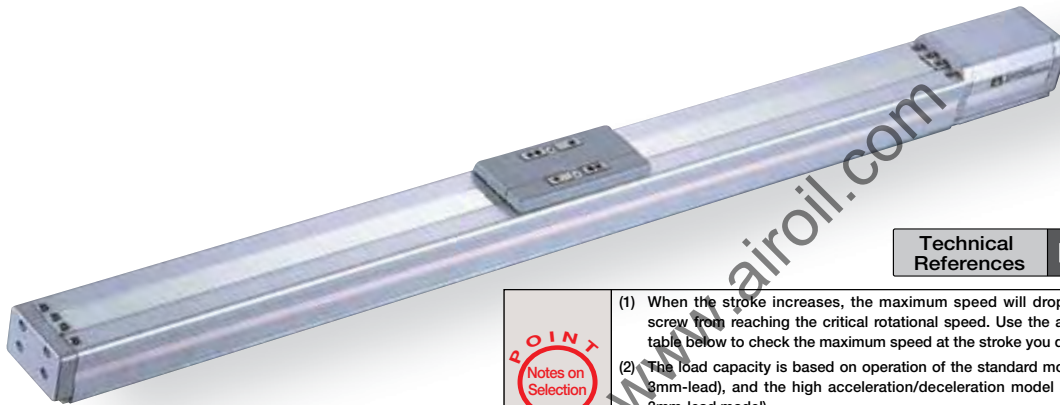

Technical References P. A-5

- POINT**
Notes on Selection
- When the stroke increases, the maximum speed will drop to prevent the ball screw from reaching the critical rotational speed. Use the actuator specification table below to check the maximum speed at the stroke you desire.
 - The load capacity is based on operation of the standard model at 0.3G (0.2G for 3mm-lead), and the high acceleration/deceleration model at 1G (excluding the 3mm-lead model).
(Even when the acceleration/deceleration is dropped, the maximum load capacity values shown in the table below are the upper limits.)

Actuator Specifications

■ Lead and Load Capacity

Model	Motor Output (W)	Lead (mm)	Max. Load Capacity		Rated Thrust (N)	Stroke (mm)
			Horizontal (kg)	Vertical (kg)		
RCS2-SA6C-①-30-12-②-③-④-⑤	30	12	6	1.5	24.2	50 ~ 600 (50mm increments)
RCS2-SA6C-①-30-6-②-③-④-⑤		6	12	3	48.4	
RCS2-SA6C-①-30-3-②-③-④-⑤		3	18	6	96.8	

■ Stroke and Maximum Speed

Stroke / Lead	50 ~ 450 (50mm increments)	500 (mm)	550 (mm)	600 (mm)
	12	800	760	640
6	400	380	320	270
3	200	190	160	135

Legend ① Encoder ② Stroke ③ Compatible controller ④ Cable length ⑤ Options (Unit: mm/s)

Encoder & Stroke List

② Stroke (mm)	Standard Price	
	① Encoder Type	
	Incremental	Absolute
50	-	-
100	-	-
150	-	-
200	-	-
250	-	-
300	-	-
350	-	-
400	-	-
450	-	-
500	-	-
550	-	-
600	-	-

④ Cable List

Type	Cable Symbol	Standard Price
Standard	P (1m)	—
	S (3m)	—
	M (5m)	—
Special Lengths	X06 (6m) ~ X10 (10m)	—
	X11 (11m) ~ X15 (15m)	—
	X16 (16m) ~ X20 (20m)	—
	R01 (1m) ~ R03 (3m)	—
Robot Cable	R04 (4m) ~ R05 (5m)	—
	R06 (6m) ~ R10 (10m)	—
	R11 (11m) ~ R15 (15m)	—
	R16 (16m) ~ R20 (20m)	—

* For cables for maintenance, see page A-39.

⑤ Option List

Name	Option Code	See Page	Standard Price
Brake	B	→ A-25	—
Foot bracket	FT	→ A-29	—
For High Acceleration/Deceleration	HA	→ A-32	—
Home sensor	HS	→ A-33	—
Reversed-home	NM	→ A-33	—
Slider Roller	SR	→ A-36	—

* The high-acceleration/deceleration option and the slider roller option cannot be used together.
* The high acceleration/deceleration option cannot be used on the 3mm-lead model.

Actuator Specifications

Item	Description
Drive System	Ball screw Ø10mm C10 grade
Positioning Repeatability	±0.02mm
Lost Motion	0.1mm or less
Base	Material: Aluminum (white alumite treated)
Allowable Static Moment	Ma: 38.3N·m Mb: 54.7N·m Mc: 81.0N·m
Allowable Dynamic Moment (*)	Ma: 8.9 N·m Mb: 12.7 N·m Mc: 18.6 N·m
Overhang Load Length	Ma direction: 220mm or less Mb-Mc direction: 220mm or less
Ambient Operating Temp./Humidity	0~40°C, 85% RH or less (Non-condensing)

(*) Based on 5,000km travel life.

Directions of Allowable Load Moments

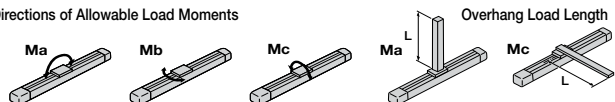

Dimensions

CAD drawings can be downloaded from IAI website. www.intelligentactuator.com

For Special Orders P. A-9



- *1 A motor-encoder cable is connected here. See page A-39 for details on cables.
- *2 When homing, the slider moves to the ME; therefore, please watch for any interference with the surrounding objects.
ME: Mechanical end SE: Stroke end
- *3 Reference position for calculating the moment M_a .

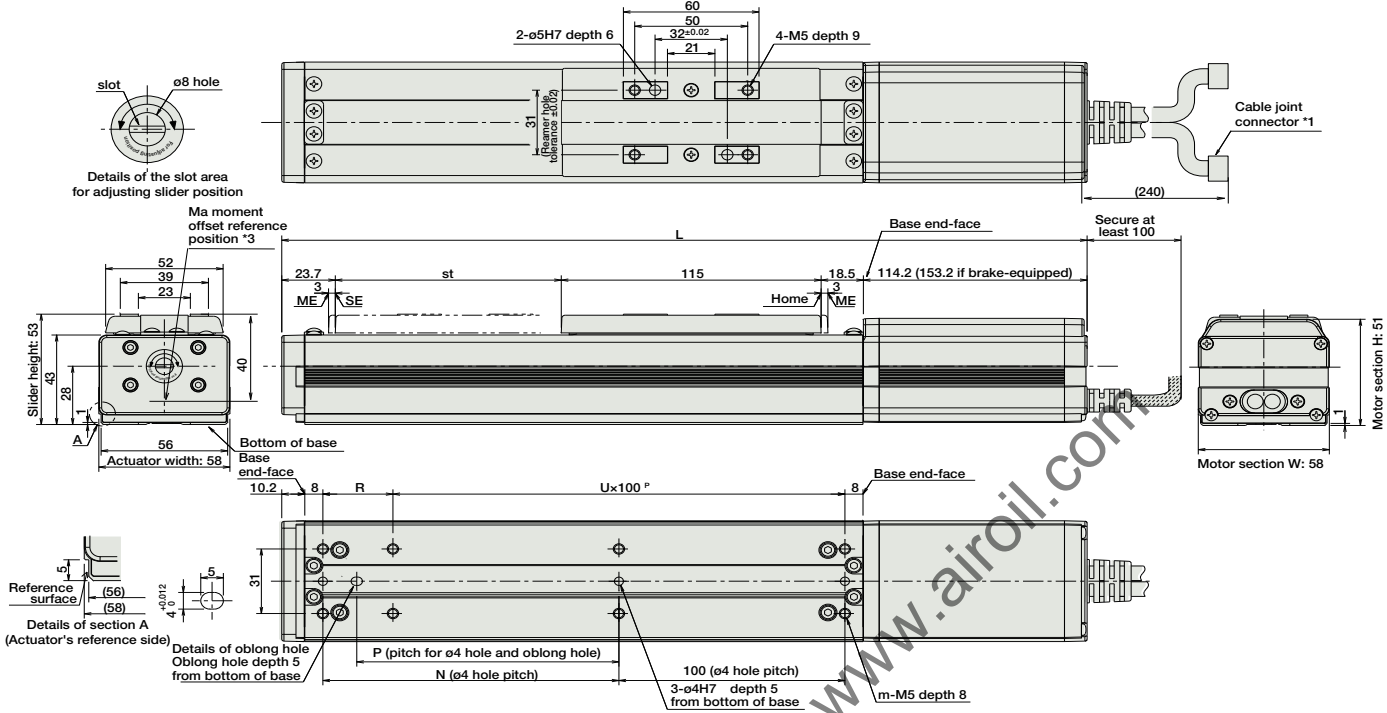

Dimensions/Weight by Stroke

* Brake-equipped models are heavier by 0.3kg.

Stroke	50	100	150	200	250	300	350	400	450	500	550	600
No Brake	321.4	371.4	421.4	471.4	521.4	571.4	621.4	671.4	721.4	771.4	821.4	871.4
With Brake	360.4	410.4	460.4	510.4	560.4	610.4	660.4	710.4	760.4	810.4	860.4	910.4
N	81	131	181	231	281	331	381	431	481	531	581	631
P	66	116	166	216	266	316	366	416	466	516	566	616
R	81	31	81	31	81	31	81	31	81	31	81	31
U	1	2	2	3	3	4	4	5	5	6	6	7
m	6	8	8	10	10	12	12	14	14	16	16	18
Weight (kg)	1.4	1.6	1.8	2	2.2	2.4	2.6	2.8	3	3.2	3.4	3.6

Compatible Controllers

The RCS2 series actuators can operate with the controllers below. Select the controller according to your usage.

Name	External View	Model	Description	Max. Positioning Points	Input Voltage	Power Supply Capacity	Standard Price	See Page
Positioner Mode		SCON-C-30D ①②-NP-2-③	Positioning is possible for up to 512 points	512 points	Single-Phase AC 100V Single-Phase AC 200V 3-Phase AC 200V (XSEL-P/Q only)	360VA max. * When operating a 150W single-axis model	—	→ P547
Solenoid Valve Mode			Operable with same controls as solenoid valve.	7 points				
Serial Communication Type			Dedicated to serial communication	64 points				
Pulse Train Input Control Type			Dedicated to Pulse Train Input	(-)				
Program Control 1-2 Axis Type		SSEL-C-1-30D ①②-NP-2-③	Programmed operation is possible Can operate up to 2 axes	20000 points			—	→ P577
Program Control 1-6 Axis Type		XSEL-④-1-30D ①②-N1-EEE-2-⑤	Programmed operation is possible Can operate up to 6 axes	20000 points			—	→ P587

* For SSEL and XSEL, only applicable to the single-axis model.
 * ① is a placeholder for the encoder type (I: incremental, A: absolute).
 * ② is a placeholder for the code "HA" when the high acceleration/deceleration option is specified.
 * ③ is a placeholder for the power supply voltage (1: single-phase 100V, 2: single phase 200V).
 * ④ is a placeholder for the XSEL type name (J, K, P, Q).
 * ⑤ is a placeholder for the power supply voltage type (1: 100V, 2: single-phase 200V, 3: 3-phase 200V).

- Slider Type
- Mini
- Standard
- Controllers Integrated
- Rod Type
- Mini
- Standard
- Controllers Integrated
- Table/Arm/Flat Type
- Mini
- Standard
- Controllers Integrated
- Gripper/Rotary Type
- Linear Servo Type
- Cleanroom Type
- Splash-Proof
- Controllers
- PMEC/AMEC
- PSEP/ASEP
- ROBO NET
- ERC2
- PCON
- ACON
- SCON
- PSEL
- ASEL
- SSEL
- XSEL
- Pulse Motor
- Servo Motor (24V)
- Servo Motor (200V)
- Linear Servo Motor

RCS2-SA7C ROBO Cylinder Slider Type 73mm Width 200V Servo Motor Coupled

■ Configuration: **RCS2** — **SA7C** — — **60** — — — — — — —

Series	Type	Encoder	Motor	Lead	Stroke	Compatible Controllers	Cable Length	Option
I : Incremental A : Absolute	60: 60W Servo motor	12: 12mm 6: 6mm 3: 3mm	50: 50mm 800: 800mm (50mm pitch increments)	T1: XSEL-J/K T2: SCON SSEL XSEL-P/Q	N : None P : 1m S : 3m M : 5m X <input type="checkbox"/> : Custom Length R <input type="checkbox"/> : Robot Cable	See Options below		

* See page Pre-35 for explanation of each code that makes up the configuration name.

For High Acceleration/Deceleration

(excluding the 4-mm lead model)

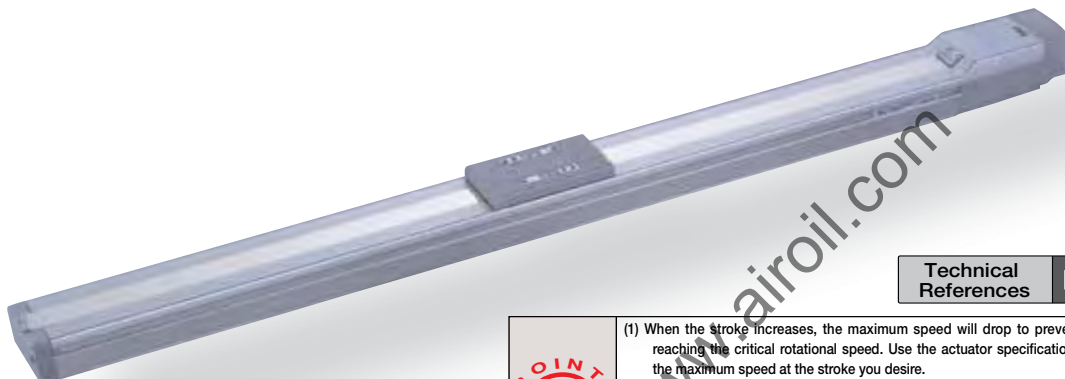

Technical References P. A-5

- POINT Notes on Selection**
- (1) When the stroke increases, the maximum speed will drop to prevent the ball screw from reaching the critical rotational speed. Use the actuator specification table below to check the maximum speed at the stroke you desire.
 - (2) The load capacity is based on operation of standard model at 0.3G (0.2G for 4mm-lead), and of the high acceleration/deceleration model at 1G (0.8G for the 8-mm lead, and excluding the 4mm-lead model). (Even when the acceleration/deceleration is dropped, the maximum load capacity values shown in the table below are the upper limits.)

Actuator Specifications

■ Lead and Load Capacity

Model	Motor Output (W)	Lead (mm)	Max. Load Capacity		Rated Thrust (N)	Stroke (mm)
			Horizontal (kg)	Vertical (kg)		
RCS2-SA7C-①-60-16-②-③-④-⑤	60	16	12	3	63.8	50 ~ 800 (50mm increments)
RCS2-SA7C-①-60-8-②-③-④-⑤		8	25	6	127.5	
RCS2-SA7C-①-60-4-②-③-④-⑤		4	40	12	255.0	

■ Stroke and Maximum Speed

Stroke Lead	50 ~ 600 (50mm increments)	~ 700 (mm)	~ 800 (mm)
16	800	640	480
8	400	320	240
4	200	160	120

(Unit: mm/s)

Legend ① Encoder ② Stroke ③ Compatible controller ④ Cable length ⑤ Options

Encoder & Stroke List

② Stroke (mm)	Standard Price	
	① Encoder Type	
	Incremental	Absolute
50/100	I	A
150/200	-	-
250/300	-	-
350/400	-	-
450/500	-	-
550/600	-	-
650/700	-	-
750/800	-	-

④ Cable List

Type	Cable Symbol	Standard Price
Standard	P (1m)	—
	S (3m)	—
	M (5m)	—
Special Lengths	X06 (6m) ~ X10 (10m)	—
	X11 (11m) ~ X15 (15m)	—
	X16 (16m) ~ X20 (20m)	—
	R01 (1m) ~ R03 (3m)	—
Robot Cable	R04 (4m) ~ R05 (5m)	—
	R06 (6m) ~ R10 (10m)	—
	R11 (11m) ~ R15 (15m)	—
	R16 (16m) ~ R20 (20m)	—

* For cables for maintenance, see page A-39.

⑤ Option List

Name	Option Code	See Page	Standard Price
Brake (Cable exiting end)	BE	→ A-25	—
Brake (Cable exiting left)	BL	→ A-25	—
Brake (Cable exiting right)	BR	→ A-25	—
For High Acceleration/Deceleration	HA	→ A-32	—
Reversed-home	NM	→ A-33	—
Slider Roller	SR	→ A-36	—

* The high-acceleration/deceleration option and the slider roller option cannot be used together.
* The high acceleration/deceleration option cannot be used on the 4mm-lead model.

Actuator Specifications

Item	Description
Drive System	Ball screw ø12mm C10 grade
Positioning Repeatability	±0.02mm
Lost Motion	0.1mm or less
Base	Material: Aluminum (white alumite treated)
Allowable Static Moment	Ma: 50.4 N·m Mb: 71.9 N·m Mc: 138.0 N·m
Allowable Dynamic Moment (*)	Ma: 13.9 N·m Mb: 19.9 N·m Mc: 38.3 N·m
Overhang Load Length	Ma direction: 230mm or less Mb-Mc direction: 230mm or less
Ambient Operating Temp./Humidity	0~40°C, 85% RH or less (Non-condensing)

(*) Based on 5,000km travel life.

Directions of Allowable Load Moments

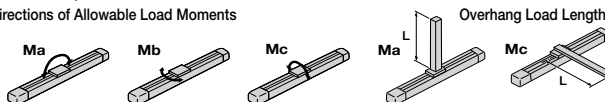

Dimensions

CAD drawings can be downloaded from IAI website. www.intelligentactuator.com

For Special Orders P. A-9



- *1 A motor-encoder cable is connected here. See page A-39 for details on cables.
- *2 When homing, the slider moves to the ME; therefore, please watch for any interference with the surrounding objects.
ME: Mechanical end SE: Stroke end
- *3 Reference position for calculating the moment Ma.

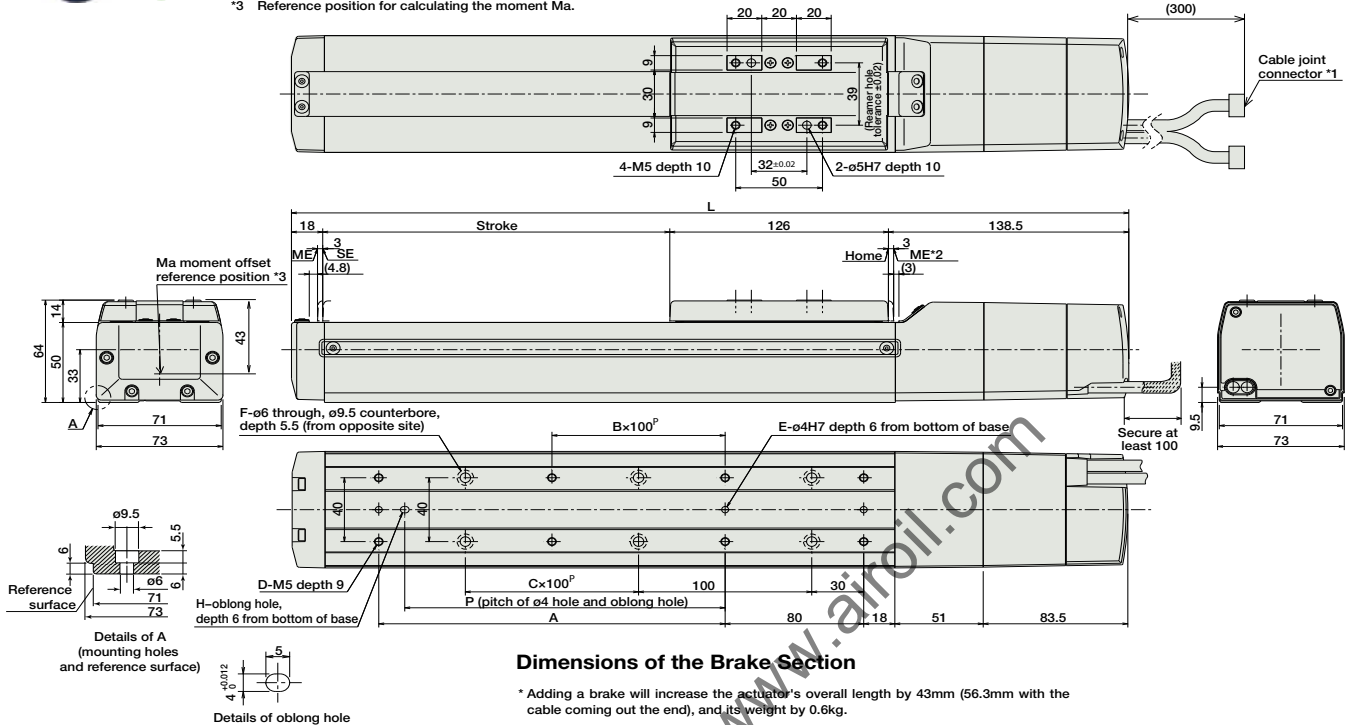

■ Dimensions/Weight by Stroke

Stroke	50	100	150	200	250	300	350	400	450	500	550	600	650	700	750	800
L	332.5	382.5	432.5	482.5	532.5	582.5	632.5	682.5	732.5	782.5	832.5	882.5	932.5	982.5	1032.5	1082.5
A	0	100	100	200	200	300	300	400	400	500	500	600	600	700	700	800
B	0	0	0	1	1	2	2	3	3	4	4	5	5	6	6	7
C	0	0	1	1	2	2	3	3	4	4	5	5	6	6	7	7
D	4	6	6	8	8	10	10	12	12	14	14	16	16	18	18	20
E	2	3	3	3	3	3	3	3	3	3	3	3	3	3	3	3
F	4	6	6	8	8	10	10	12	12	14	14	16	16	18	18	18
H	0	1	1	1	1	1	1	1	1	1	1	1	1	1	1	1
P	0	85	85	185	185	285	285	385	385	485	485	585	585	685	685	785
Weight (kg)	2.4	2.6	2.8	3.0	3.3	3.5	3.7	3.9	4.2	4.4	4.6	4.8	5.1	5.3	5.5	5.7

③ Compatible Controllers

The RCS2 series actuators can operate with the controllers below. Select the controller according to your usage.

Name	External View	Model	Description	Max. Positioning Points	Input Voltage	Power Supply Capacity	Standard Price	See Page
Positioner Mode		SCON-C-60①②-NP-2-③	Positioning is possible for up to 512 points	512 points	Single-Phase AC 100V Single-Phase AC 200V 3-Phase AC 200V (XSEL-P/Q only)	360VA max. * When operating a 150W single-axis model	—	→ P547
Solenoid Valve Mode			Operable with same controls as solenoid valve.	7 points				
Serial Communication Type			Dedicated to serial communication	64 points				
Pulse Train Input Control Type		SSEL-C-1-60①②-NP-2-③	Dedicated to Pulse Train Input	(-)	3-Phase AC 200V (XSEL-P/Q only)	360VA max. * When operating a 150W single-axis model	—	→ P577
Program Control 1-2 Axis Type			Programmed operation is possible. Can operate up to 2 axes	20000 points				
Program Control 1-6 Axis Type			Programmed operation is possible. Can operate up to 6 axes	20000 points				

* For SSEL and XSEL, only applicable to the single-axis model.
 * ① is a placeholder for the encoder type (I: incremental, A: absolute).
 * ② is a placeholder for the code "HA" when the high acceleration/deceleration option is specified.
 * ③ is a placeholder for the power supply voltage (1: single-phase 100V, 2: single phase 200V).
 * ④ is a placeholder for the XSEL type name (J, K, P, Q).
 * ⑤ is a placeholder for the power supply voltage type (1: 100V, 2: single-phase 200V, 3: 3-phase 200V).

- Slider Type
- Mini
- Standard
- Controllers Integrated
- Rod Type
- Mini
- Standard
- Controllers Integrated
- Table/Arm/Flat Type
- Mini
- Standard
- Gripper/Rotary Type
- Linear Servo Type
- Cleanroom Type
- Splash-Proof
- Controllers
- PMEC /AMEC
- PSEP /ASEP
- ROBO NET
- ERC2
- PCON
- ACON
- SCON
- PSEL
- ASEL
- SSEL
- XSEL
- Pulse Motor
- Servo Motor (24V)
- Servo Motor (200V)
- Linear Servo Motor

RCS2-SS7C

ROBO Cylinder Slider Type 60mm Width 200V Servo Motor Coupled Steel Base

■ Configuration: **RCS2** — **SS7C** — — **60** — — — —

Series — Type — Encoder — Motor — Lead — Stroke — Compatible Controllers — Cable Length — Option

I : Incremental
A : Absolute

60: 60W Servo motor

12: 12mm
6: 6mm

50: 50mm
600: 600mm (50mm pitch increments)

T1: XSEL-J/K
T2: SCON
SSEL
XSEL-P/Q

N : None
P : 1m
S : 3m
M : 5m
X : Custom Length
R : Robot Cable

See Options below
NM: Reversed-home
SR : Slider Roller

* See page Pre-35 for explanation of each code that makes up the configuration name.

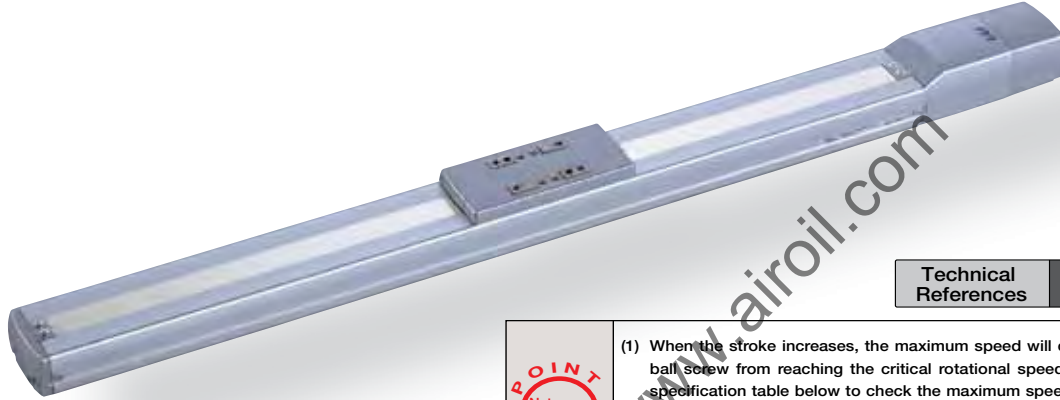

Technical References P. A-5

POINT
Notes on Selection

(1) When the stroke increases, the maximum speed will drop to prevent the ball screw from reaching the critical rotational speed. Use the actuator specification table below to check the maximum speed at the stroke you desire.

(2) The load capacity is based on operation at an acceleration of 0.3G. These values are the upper limits for the acceleration.

Actuator Specifications

Lead and Load Capacity

Model	Motor Output (W)	Lead (mm)	Max. Load Capacity		Rated Thrust (N)	Stroke (mm)
			Horizontal (kg)	Vertical (kg)		
RCS2-SS7C-①-60-12-②-③-④-⑤	60	12	15	4	85	50 ~ 600 (50mm increments)
RCS2-SS7C-①-60-6-②-③-④-⑤		6	30	8	170	

Legend ① Encoder ② Stroke ③ Compatible controller ④ Cable length ⑤ Options

Stroke and Maximum Speed

Stroke Lead	50 ~ 500 (50mm increments)	~ 600 (mm)
	12	600
6	300	230

(Unit: mm/s)

Encoder & Stroke List

② Stroke (mm)	Standard Price	
	① Encoder Type	
	Incremental	Absolute
50/100	I	A
150/200	-	-
250/300	-	-
350/400	-	-
450/500	-	-
550/600	-	-

④ Cable List

Type	Cable Symbol	Standard Price
Standard	P (1m)	—
	S (3m)	—
	M (5m)	—
Special Lengths	X06 (6m) ~ X10 (10m)	—
	X11 (11m) ~ X15 (15m)	—
	X16 (16m) ~ X20 (20m)	—
	R01 (1m) ~ R03 (3m)	—
Robot Cable	R04 (4m) ~ R05 (5m)	—
	R06 (6m) ~ R10 (10m)	—
	R11 (11m) ~ R15 (15m)	—
	R16 (16m) ~ R20 (20m)	—

* For cables for maintenance, see page A-39.

⑤ Option List

Name	Option Code	See Page	Standard Price
Brake	B	→ A-25	—
Reversed-home	NM	→ A-33	—
Slider Roller	SR	→ A-36	—

Actuator Specifications

Item	Description
Drive System	Ball screw Ø10mm C10 grade
Positioning Repeatability	±0.02mm
Lost Motion	0.1mm or less
Base	Material: Special alloy steel
Allowable Static Moment	Ma: 79.4 N-m Mb: 79.4 N-m Mc: 172.9 N-m
Allowable Dynamic Moment (*)	Ma: 14.7 N-m Mb: 14.7 N-m Mc: 33.3 N-m
Overhang Load Length	Ma direction: 300mm or less Mb-Mc direction: 300mm or less
Ambient Operating Temp./Humidity	0~40°C, 85% RH or less (Non-condensing)

(*) Based on 10,000km travel life.

Directions of Allowable Load Moments

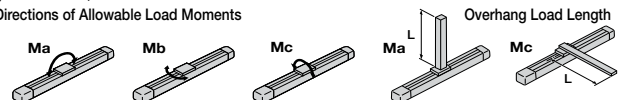

Dimensions

CAD drawings can be downloaded from IAI website. www.intelligentactuator.com

For Special Orders P. A-9



- *1 A motor-encoder cable is connected here. See page A-39 for details on cables.
- *2 When homing, the slider moves to the ME; therefore, please watch for any interference with the surrounding objects.
ME: Mechanical end SE: Stroke end
- *3 Reference position for calculating the moment Ma.

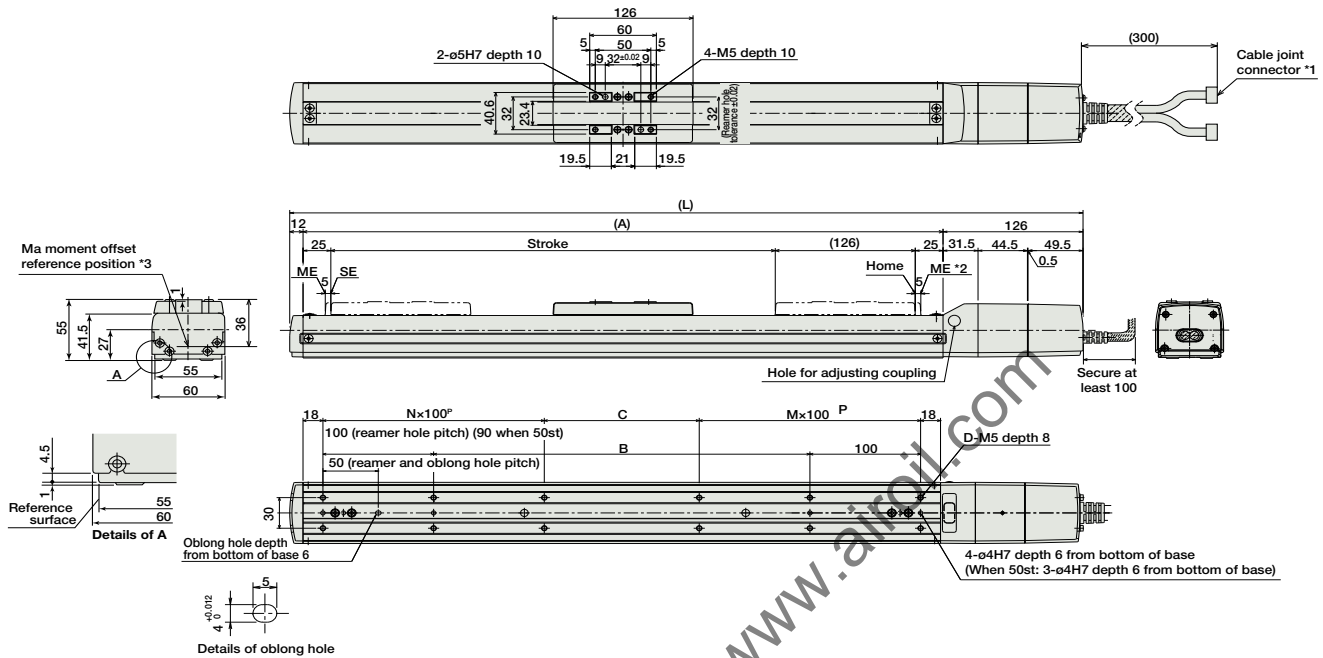

Dimensions of the Brake Section

* Adding a brake increases the actuator's overall length by 24.5mm and its weight by 0.3kg.

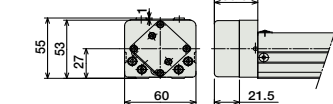

Dimensions/Weight by Stroke

Stroke	50	100	150	200	250	300	350	400	450	500	550	600
L	364	414	464	514	564	614	664	714	764	814	864	914
A	226	276	326	376	426	476	526	576	626	676	726	776
B	0	40	90	140	190	240	290	340	390	440	490	540
C	90	40	90	140	190	40	90	140	190	40	90	140
D	6	8	8	8	8	12	12	12	12	16	16	16
M	1	1	1	1	1	2	2	2	2	3	3	3
N	0	1	1	1	1	2	2	2	2	3	3	3
Weight (kg)	4.9	3.2	3.5	3.8	4.2	4.5	4.8	5.1	5.5	5.8	6.1	6.4

3 Compatible Controllers

The RCS2 series actuators can operate with the controllers below. Select the controller according to your usage.

Name	External View	Model	Description	Max. Positioning Points	Input Voltage	Power Supply Capacity	Standard Price	See Page
Positioner Mode		SCON-C-60①-NP-2-②	Positioning is possible for up to 512 points	512 points	Single-Phase AC 100V Single-Phase AC 200V 3-Phase AC 200V (XSEL-P/Q only)	360VA max. * When operating a 150W single-axis model	—	→ P547
Solenoid Valve Mode			Operable with same controls as solenoid valve.	7 points				
Serial Communication Type			Dedicated to serial communication	64 points				
Pulse Train Input Control Type			Dedicated to Pulse Train Input	(-)				
Program Control 1-2 Axis Type		SSEL-C-1-60①-NP-2-②	Programmed operation is possible Can operate up to 2 axes	20000 points			—	→ P577
Program Control 1-6 Axis Type		XSEL-③-1-60①-N1-EEE-2-④	Programmed operation is possible Can operate up to 6 axes	20000 points			—	→ P587

* For SSEL and XSEL, only applicable to the single-axis model.
 * ① is a placeholder for the encoder type (I: incremental, A: absolute).
 * ② is a placeholder for the power supply voltage (1: 100V, 2: single-phase 200V, 3: 3-phase 200V).
 * ③ is a placeholder for the XSEL type name (J, K, P, or Q).
 * ④ is a placeholder for the power supply voltage (1: 100V, 2: single-phase 200V, 3: 3-phase 200V).

- Slider Type
- Mini
- Standard
- Controllers Integrated
- Rod Type
- Mini
- Standard
- Controllers Integrated
- Table/Arm/Flat Type
- Mini
- Standard
- Gripper/Rotary Type
- Linear Servo Type
- Cleanroom Type
- Splash-Proof
- Controllers
- PMEC /AMEC
- PSEP /ASEP
- ROBO NET
- ERC2
- PCON
- ACON
- SCON
- PSEL
- ASEL
- SSEL
- XSEL
- Pulse Motor
- Servo Motor (24V)
- Servo Motor (200V)
- Linear Servo Motor

RCS2-SS8C

ROBO Cylinder Slider Type 80mm Width 200V Servo Motor Coupled Steel Base

■ Configuration: **RCS2** — **SS8C** — [] — [] — [] — [] — [] — [] — []

Series — Type — Encoder — Motor — Lead — Stroke — Compatible Controllers — Cable Length — Option

I : Incremental
A: Absolute

100: 100W Servo motor
150: 150W Servo motor

20: 20mm
10: 10mm

50: 50mm
1000: 1000mm (50mm pitch increments)

T1: XSEL-J/K
T2: SCON
SSEL
XSEL-P/Q

N : None
P : 1m
S : 3m
M : 5m
X [] : Custom Length
R [] : Robot Cable

B : Brake
NM : Reversed-home
SR : Slider Roller

* See page Pre-35 for explanation of each code that makes up the configuration name.

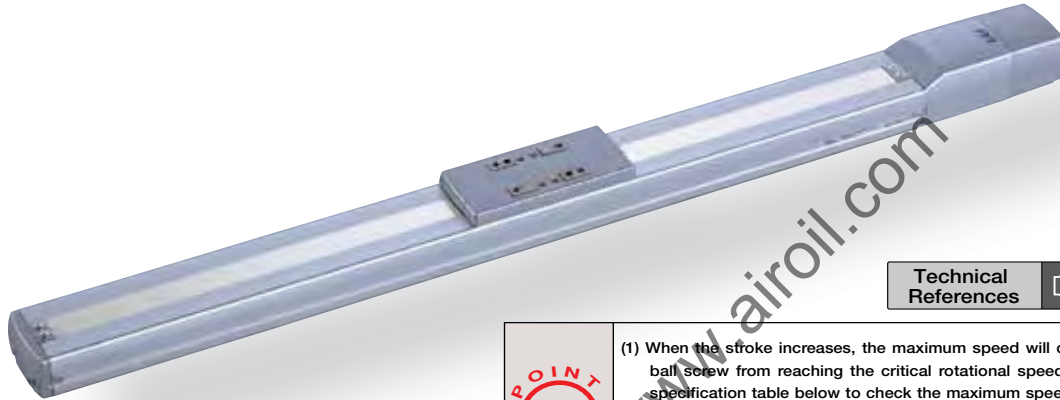

Technical References P. A-5

POINT
Notes on Selection

(1) When the stroke increases, the maximum speed will drop to prevent the ball screw from reaching the critical rotational speed. Use the actuator specification table below to check the maximum speed at the stroke you desire.

(2) The load capacity is based on operation at an acceleration of 0.3G. These values are the upper limits for the acceleration.

Actuator Specifications

Lead and Load Capacity

Model	Motor Output (W)	Lead (mm)	Max. Load Capacity Horizontal (kg) / Vertical (kg)	Rated Thrust (N)	Stroke (mm)
RCS2-SS8C-①-100-20-②-③-④-⑤	100	20	20 / 4	84.9	50 ~ 1000 (50mm increments)
RCS2-SS8C-①-100-10-②-③-④-⑤		10	40 / 8	169	
RCS2-SS8C-①-150-20-②-③-④-⑤	150	20	30 / 6	128	
RCS2-SS8C-①-150-10-②-③-④-⑤		10	60 / 12	256	

Stroke and Maximum Speed

Stroke Lead	50 ~ 600 (50mm increments)	~ 700 (mm)	~ 800 (mm)	~ 900 (mm)	~ 1000 (mm)
20	1000	960	765	625	515
10	500	480	380	310	255

(Unit: mm/s)

Legend ① Encoder ② Stroke ③ Compatible controller ④ Cable length ⑤ Options

Encoder & Stroke List

② Stroke (mm)	Standard Price			
	① Encoder Type			
	Incremental		Absolute	
	Motor power output		Motor power output	
	100W	150W	100W	150W
50/100	-	-	-	-
150/200	-	-	-	-
250/300	-	-	-	-
350/400	-	-	-	-
450/500	-	-	-	-
550/600	-	-	-	-
650/700	-	-	-	-
750/800	-	-	-	-
850/900	-	-	-	-
950/1000	-	-	-	-

④ Cable List

Type	Cable Symbol	Standard Price
Standard	P (1m)	—
	S (3m)	—
	M (5m)	—
Special Lengths	X06 (6m) ~ X10 (10m)	—
	X11 (11m) ~ X15 (15m)	—
	X16 (16m) ~ X20 (20m)	—
	R01 (1m) ~ R03 (3m)	—
Robot Cable	R04 (4m) ~ R05 (5m)	—
	R06 (6m) ~ R10 (10m)	—
	R11 (11m) ~ R15 (15m)	—
	R16 (16m) ~ R20 (20m)	—

* For cables for maintenance, see page A-39.

⑤ Option List

Name	Option Code	See Page	Standard Price
Brake	B	→ A-25	—
Reversed-home	NM	→ A-33	—
Slider Roller	SR	→ A-36	—

Actuator Specifications

Item	Description
Drive System	Ball screw ø16mm C10 grade
Positioning Repeatability	±0.02mm
Lost Motion	0.1mm or less
Base	Material: Special alloy steel
Allowable Static Moment	Ma: 198.9 N·m Mb: 198.9 N·m Mc: 416.7 N·m
Allowable Dynamic Moment (*)	Ma: 36.3 N·m Mb: 36.3 N·m Mc: 77.4 N·m
Overhang Load Length	Ma direction: 450mm or less Mb-Mc direction: 450mm or less
Ambient Operating Temp./Humidity	0 ~ 40°C, 85% RH or less (Non-condensing)

(*) Based on 10,000km travel life.

Directions of Allowable Load Moments

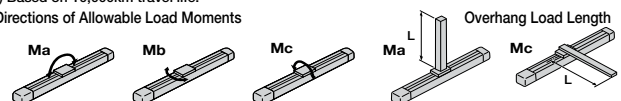

Dimensions

CAD drawings can be downloaded from IAI website. www.intelligentactuator.com

For Special Orders P. A-9



- *1 A motor-encoder cable is connected here. See page A-39 for details on cables.
- *2 When homing, the slider moves to the ME; therefore, please watch for any interference with the surrounding objects.
ME: Mechanical end SE: Stroke end
- *3 Reference position for calculating the moment Ma.

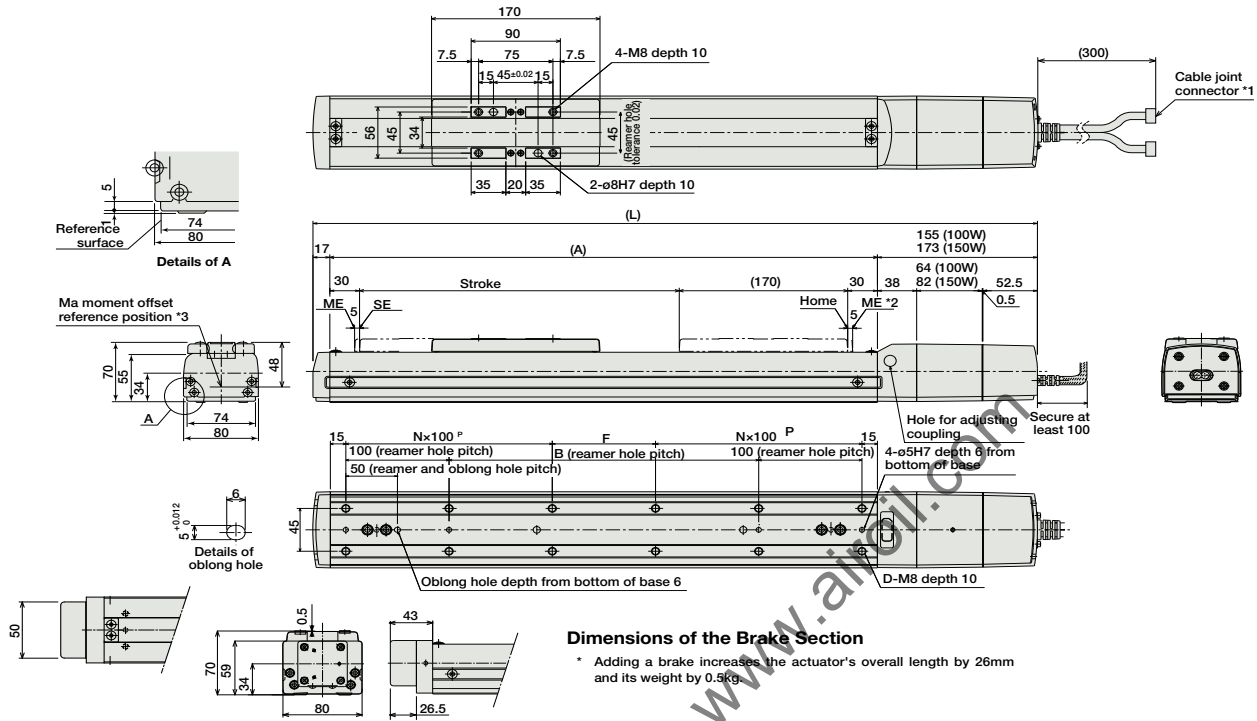

Dimensions of the Brake Section

* Adding a brake increases the actuator's overall length by 26mm and its weight by 0.9kg.

■ Dimensions/Weight by Stroke

Stroke	50	100	150	200	250	300	350	400	450	500	550	600	650	700	750	800	850	900	950	1000
L (100W)	452	502	552	602	652	702	752	802	852	902	952	1002	1052	1102	1152	1202	1252	1302	1352	1402
L (150W)	470	520	570	620	670	720	770	820	870	920	970	1020	1070	1120	1170	1220	1270	1320	1370	1420
A	280	330	380	430	480	530	580	630	680	730	780	830	880	930	980	1030	1080	1130	1180	1230
B	50	100	150	200	250	300	350	400	450	500	550	600	650	700	750	800	850	900	950	1000
D	8	8	8	10	12	12	12	14	16	16	16	18	20	20	20	22	24	24	24	26
F	50	100	150	0	50	100	150	0	50	100	150	0	50	100	150	0	50	100	150	0
N	1	1	1	2	2	2	2	3	3	3	3	4	4	4	4	5	5	5	5	6
Weight (kg)	6.0	6.5	7.1	7.6	8.2	8.7	9.3	9.8	10.4	10.9	11.5	12.0	12.6	13.1	13.7	14.2	14.8	15.3	15.9	16.4

③ Compatible Controllers

The RCS2 series actuators can operate with the controllers below. Select the controller according to your usage.

Name	External View	Model	Description	Max. Positioning Points	Input Voltage	Power Supply Capacity	Standard Price	See Page
Positioner Mode		SCON-C-100①-NP-2-② SCON-C-150①-NP-2-②	Positioning is possible for up to 512 points	512 points	Single-Phase AC 100V Single-Phase AC 200V 3-Phase AC 200V (XSEL-P/Q only)	360VA max. * When operating a 150W single-axis model	—	→ P547
Solenoid Valve Mode			Operable with same controls as solenoid valve.	7 points				
Serial Communication Type			Dedicated to serial communication	64 points				
Pulse Train Input Control Type			Dedicated to Pulse Train Input	(-)				
Program Control 1-2 Axis Type		SSEL-C-1-100①-NP-2-② SSEL-C-1-150①-NP-2-②	Programmed operation is possible Can operate up to 2 axes	20000 points			—	→ P577
Program Control 1-6 Axis Type		XSEL-③-1-100①-N1-EEE-2-④ XSEL-③-1-150①-N1-EEE-2-④	Programmed operation is possible Can operate up to 6 axes	20000 points			—	→ P587

* For SSEL and XSEL, only applicable to the single-axis model.
 * ① is a placeholder for the encoder type (I: incremental, A: absolute).
 * ② is a placeholder for the power supply voltage (1: 100V, 2: single-phase 200V)
 * ③ is a placeholder for the XSEL type name (J, K, P, or Q).
 * ④ is a placeholder for the power supply voltage (1: 100V, 2: single-phase 200V, 3: 3-phase 200V).

- Slider Type
- Mini
- Standard
- Controllers Integrated
- Rod Type
- Mini
- Standard
- Controllers Integrated
- Table/Arm/Flat Type
- Mini
- Standard
- Gripper/Rotary Type
- Linear Servo Type
- Cleanroom Type
- Splash-Proof
- Controllers
- PMEC/AMEC
- PSEP/ASEP
- ROBO NET
- ERC2
- PCON
- ACON
- SCON
- PSEL
- ASEL
- SSEL
- XSEL
- Pulse Motor
- Servo Motor (24V)
- Servo Motor (200V)
- Linear Servo Motor

Dimensions

CAD drawings can be downloaded from IAI website. www.intelligentactuator.com

For Special Orders P. A-9

2D CAD

- *1 A motor-encoder cable is connected here. See page A-39 for details on cables.
- *2 When homing, the slider moves to the ME; therefore, please watch for any interference with the surrounding objects.
ME: Mechanical end SE: Stroke end
- *3 Reference position for calculating the moment Ma.
- *4 If the actuator is secured using only the mounting holes provided on the top surface of the base, the base may twist to cause abnormal sliding of the slider, or may produce abnormal noise. Therefore, when using the mounting holes on the top surface of the base, keep the stroke at 200mm or less.

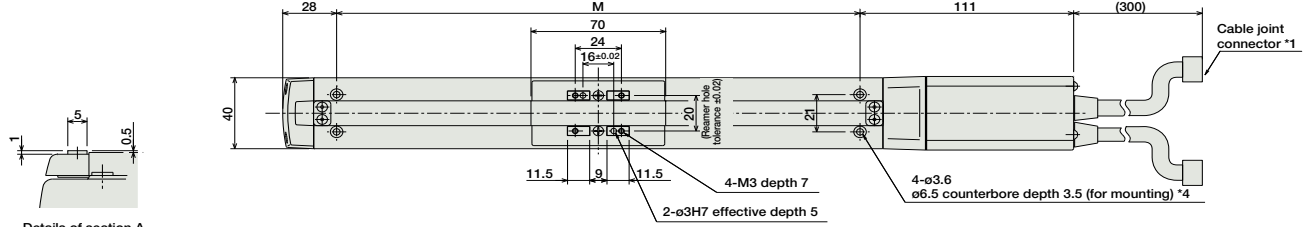

Details of section A

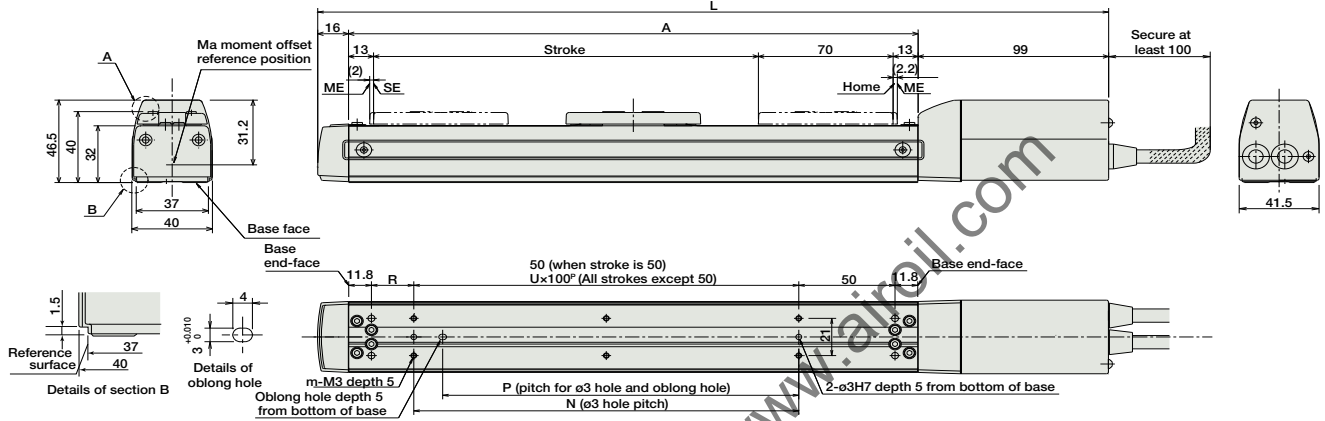

Dimensions of the Brake Section

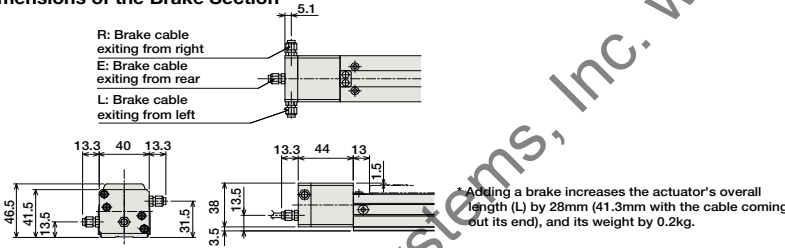

■ Dimensions/Weight by Stroke

Stroke	50	100	150	200	250	300
L	261	311	361	411	461	511
A	146	196	246	296	346	396
M	122	172	222	272	322	372
N	50	100	100	200	200	300
P	35	85	85	185	185	285
R	22	22	72	22	72	22
U	-	1	1	2	2	3
m	4	4	4	6	6	8
Weight (kg)	0.8	0.9	1.0	1.1	1.2	1.3

③ Compatible Controllers

The RCS2 series actuators can operate with the controllers below. Select the controller according to your usage.

Name	External View	Model	Description	Max. Positioning Points	Input Voltage	Power Supply Capacity	Standard Price	See Page
Positioner Mode		SCON-C-20①-NP-2-②	Positioning is possible for up to 512 points	512 points	Single-Phase AC 100V Single-Phase AC 200V 3-Phase AC 200V (XSEL-P/Q only)	360VA max. * When operating a 150W single-axis model	-	→ P547
Solenoid Valve Mode			Operable with same controls as solenoid valve.	7 points				
Serial Communication Type			Dedicated to serial communication	64 points				
Pulse Train Input Control Type			Dedicated to Pulse Train Input	(-)				
Program Control 1-2 Axis Type		SSEL-C-1-20①-NP-2-②	Programmed operation is possible Can operate up to 2 axes	20000 points			-	→ P577
Program Control 1-6 Axis Type		XSEL-③-1-20①-N1-EEE-2-④	Programmed operation is possible Can operate up to 6 axes	20000 points			-	→ P587

* For SSEL and XSEL, only applicable to the single-axis model.
 * ① is a placeholder for the encoder type (I: incremental, A: absolute).
 * ② is a placeholder for the power supply voltage (1: 100V, 2: single-phase 200V, 3: 3-phase 200V).
 * ③ is a placeholder for the XSEL type name (J, K, P, or Q).
 * ④ is a placeholder for the power supply voltage (1: 100V, 2: single-phase 200V, 3: 3-phase 200V).

- Slider Type
- Mini
- Standard
- Controllers Integrated
- Rod Type
- Mini
- Standard
- Controllers Integrated
- Table/Arm/Flat Type
- Mini
- Standard
- Gripper/Rotary Type
- Linear Servo Type
- Cleanroom Type
- Splash-Proof
- Controllers
- PMEC/AMEC
- PSEP/ASEP
- ROBO NET
- ERC2
- PCON
- ACON
- SCON
- PSEL
- ASEL
- SSEL
- XSEL
- Pulse Motor
- Servo Motor (24V)
- Servo Motor (200V)
- Linear Servo Motor

RCS2-SA5D

ROBO Cylinder Slider Type 52mm Width 200V Servo Motor
Motor Built-In (Direct Coupled)

■ Configuration: **RCS2** — **SA5D** — — **20** — — — — —

Series — Type — Encoder — Motor — Lead — Stroke — Compatible Controllers — Cable Length — Option

I : Incremental A: Absolute 20: 20W Servo motor 12: 12mm 6: 6mm 3: 3mm 50: 50mm 500: 500mm (50mm pitch increments) T1: XSEL-J/K T2: SCON SSEL XSEL-P/Q N : None P : 1m S : 3m M : 5m X : Custom Length SR : Slider Roller R : Robot Cable BE : Brake (Cable exiting end) BL : Brake (Cable exiting left) BR : Brake (Cable exiting right) NM: Reversed-home

* See page Pre-35 for explanation of each code that makes up the configuration name.

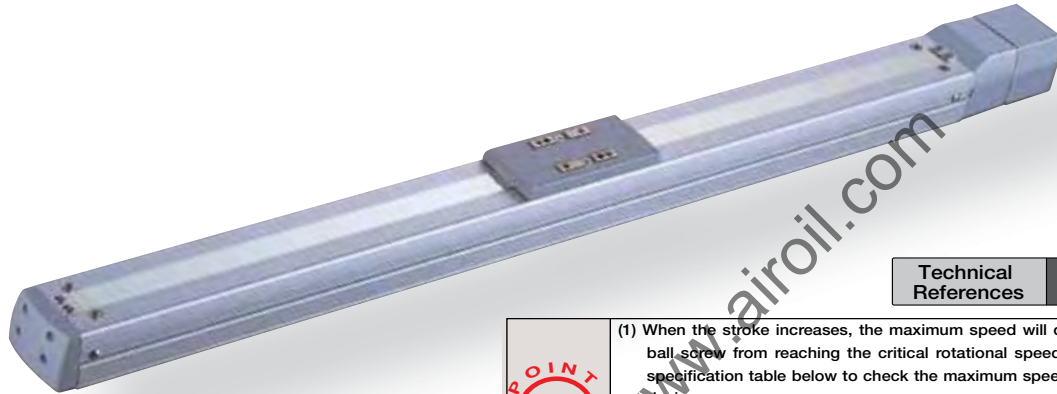

Technical References P. A-5

POINT Notes on Selection

(1) When the stroke increases, the maximum speed will drop to prevent the ball screw from reaching the critical rotational speed. Use the actuator specification table below to check the maximum speed at the stroke you desire.

(2) The load capacity is based on operation at an acceleration of 0.3G (0.2G for the 3mm-lead model). These values are the upper limits for the acceleration.

Actuator Specifications							
■ Lead and Load Capacity							
Model	Motor Output (W)	Lead (mm)	Max. Load Capacity		Rated Thrust (N)	Stroke (mm)	
RCS2-SA5D-①-20-12-②-③-④-⑤	20	12	Horizontal (kg)	Vertical (kg)	16.7	50 ~ 500 (50mm increments)	
RCS2-SA5D-①-20-6-②-③-④-⑤		6	8	2			33.3
RCS2-SA5D-①-20-3-②-③-④-⑤		3	12	4			65.7

■ Stroke and Maximum Speed			
Stroke Lead	50 ~ 450 (50mm increments)	500 (mm)	
12	800	760	
6	400	380	
3	200	190	

Legend ① Encoder ② Stroke ③ Compatible controller ④ Cable length ⑤ Options (Unit: mm/s)

Encoder & Stroke List		
② Stroke (mm)	Standard Price	
	① Encoder Type	
	Incremental	Absolute
	I	A
50	-	-
100	-	-
150	-	-
200	-	-
250	-	-
300	-	-
350	-	-
400	-	-
450	-	-
500	-	-

④ Cable List		
Type	Cable Symbol	Standard Price
Standard	P (1m)	—
	S (3m)	—
	M (5m)	—
Special Lengths	X06 (6m) ~ X10 (10m)	—
	X11 (11m) ~ X15 (15m)	—
	X16 (16m) ~ X20 (20m)	—
	R01 (1m) ~ R03 (3m)	—
Robot Cable	R04 (4m) ~ R05 (5m)	—
	R06 (6m) ~ R10 (10m)	—
	R11 (11m) ~ R15 (15m)	—
	R16 (16m) ~ R20 (20m)	—

* For cables for maintenance, see page A-39.

⑤ Option List			
Name	Option Code	See Page	Standard Price
Brake (Cable exiting end)	BE	→ A-25	—
Brake (Cable exiting left)	BL	→ A-25	—
Brake (Cable exiting right)	BR	→ A-25	—
Reversed-home	NM	→ A-33	—
Slider Roller	SR	→ A-36	—

Actuator Specifications	
Item	Description
Drive System	Ball screw Ø10mm C10 grade
Positioning Repeatability	±0.02mm
Lost Motion	0.1mm or less
Base	Material: Aluminum (white alumite treated)
Allowable Static Moment	Ma: 18.6N·m Mb: 26.6N·m Mc: 47.5N·m
Allowable Dynamic Moment (*)	Ma: 4.9N·m Mb: 6.8N·m Mc: 11.7N·m
Overhang Load Length	Ma direction: 150mm or less Mb-Mc direction: 150mm or less
Ambient Operating Temp./Humidity	0~40°C, 85% RH or less (Non-condensing)

(*) Based on 5,000km travel life.

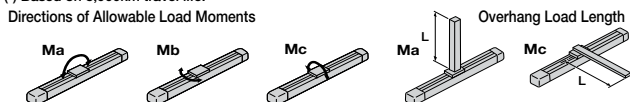

Dimensions

CAD drawings can be downloaded from IAI website. www.intelligentactuator.com

For Special Orders P. A-9

2D CAD

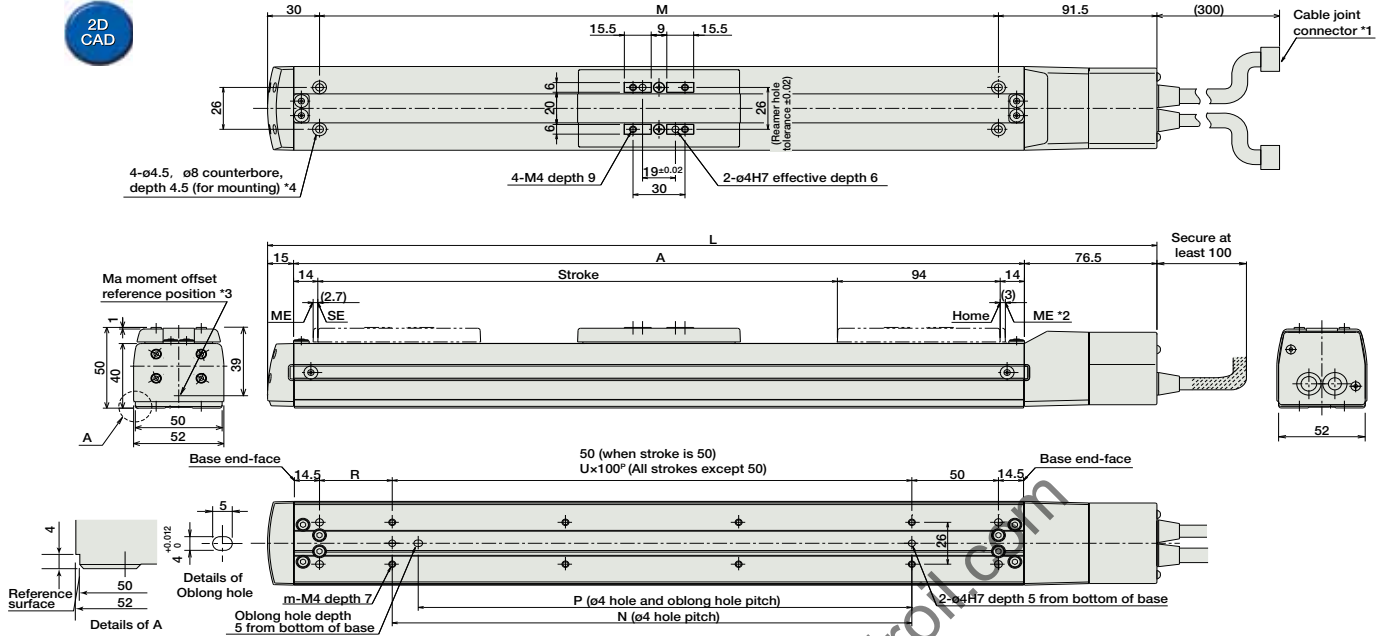

Dimensions of the Brake Section

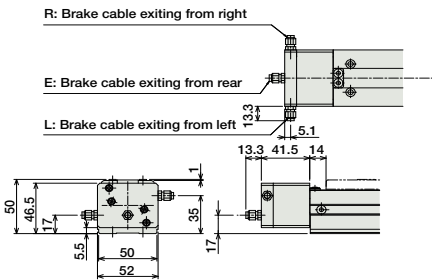

* Adding a brake increases the actuator's overall length (L) by 26.5mm (39.8mm with the cable coming out its end), and its weight by 0.3kg.

- *1 The motor-encoder cable is connected here. See page A-39 for details on cables.
- *2 When homing, the slider moves to the ME; therefore, please watch for any interference with the surrounding objects. ME: Mechanical end SE: Stroke end
- *3 Reference position for calculating the moment Ma.
- *4 If the actuator is secured using only the mounting holes provided on the top surface of the base, the base may twist to cause abnormal sliding of the slider, or may produce abnormal noise. Therefore, when using the mounting holes on the top surface of the base, keep the stroke at 300mm or less.

■ Dimensions/Weight by Stroke

Stroke	50	100	150	200	250	300	350	400	450	500
L	263.5	313.5	363.5	413.5	463.5	513.5	563.5	613.5	663.5	713.5
A	172	222	272	322	372	422	472	522	572	622
M	142	192	242	292	342	392	442	492	542	592
N	50	100	100	200	200	300	300	400	400	500
P	35	85	85	185	185	285	285	385	385	485
R	42	42	92	42	92	42	92	42	92	42
U	-	1	1	2	2	3	3	4	4	5
m	4	4	4	6	6	8	8	10	10	12
Weight (kg)	1.4	1.5	1.6	1.7	1.8	1.9	2.0	2.1	2.2	2.3

③ Compatible Controllers

The RCS2 series actuators can operate with the controllers below. Select the controller according to your usage.

Name	External View	Model	Description	Max. Positioning Points	Input Voltage	Power Supply Capacity	Standard Price	See Page
Positioner Mode		SCON-C-20①-NP-2-②	Positioning is possible for up to 512 points	512 points	Single-Phase AC 100V Single-Phase AC 200V 3-Phase AC 200V (XSEL-P/Q only)	360VA max. * When operating a 150W single-axis model	-	→ P547
Solenoid Valve Mode			Operable with same controls as solenoid valve.	7 points				
Serial Communication Type			Dedicated to serial communication	64 points				
Pulse Train Input Control Type			Dedicated to Pulse Train Input	(-)				
Program Control 1-2 Axis Type		SSEL-C-1-20①-NP-2-②	Programmed operation is possible Can operate up to 2 axes	20000 points			-	→ P577
Program Control 1-6 Axis Type		XSEL-③-1-20①-N1-EEE-2-④	Programmed operation is possible Can operate up to 6 axes	20000 points			-	→ P587

- * For SSEL and XSEL, only applicable to the single-axis model.
- * ① is a placeholder for the encoder type (I: incremental, A: absolute).
- * ② is a placeholder for the power supply voltage (1: 100V, 2: single-phase 200V, 3: 3-phase 200V).
- * ③ is a placeholder for the XSEL type name (J, K, P, or Q).
- * ④ is a placeholder for the power supply voltage (1: 100V, 2: single-phase 200V, 3: 3-phase 200V).

RCS2-SA6D

ROBO Cylinder Slider Type 58mm Width 200V Servo Motor
Motor Built-In (Direct Coupled)

■ Configuration: **RCS2** — **SA6D** — [] — **30** — [] — [] — [] — [] — []
Series — Type — Encoder — Motor — Lead — Stroke — Compatible Controllers — Cable Length — Option

I : Incremental
A : Absolute
30: 30W Servo motor
12: 12mm
6: 6mm
3: 3mm
50: 50mm
600: 600mm (50mm pitch increments)
T1: XSEL-J/K
T2: SCON
SSEL
XSEL-P/Q
N : None
P : 1m
S : 3m
M : 5m
X [] : Custom Length
R [] : Robot Cable
BE : Brake (Cable exiting end)
BL : Brake (Cable exiting left)
BR : Brake (Cable exiting right)
NM: Reversed-home
SR : Slider Roller

* See page Pre-35 for explanation of each code that makes up the configuration name.

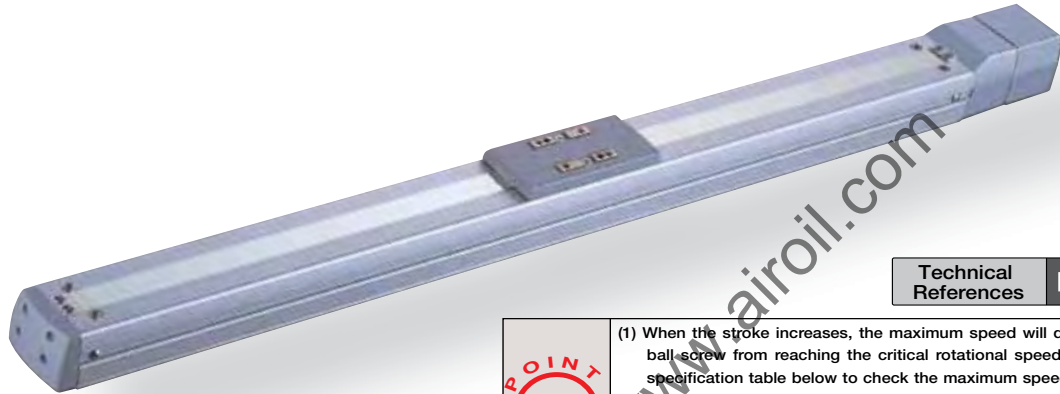

Technical References P. A-5

POINT
Notes on Selection

(1) When the stroke increases, the maximum speed will drop to prevent the ball screw from reaching the critical rotational speed. Use the actuator specification table below to check the maximum speed at the stroke you desire.
(2) The load capacity is based on operation at an acceleration of 0.3G (0.2G for the 3mm-lead model).
These values are the upper limits for the acceleration.

Actuator Specifications

■ Lead and Load Capacity

Model	Motor Output (W)	Lead (mm)	Max. Load Capacity	Rated Thrust (N)	Stroke (mm)
			Horizontal (kg) Vertical (kg)		
RCS2-SA6D-①-30-12-②-③-④-⑤	30	12	6 1.5	24.2	50 ~ 600 (50mm increments)
RCS2-SA6D-①-30-6-②-③-④-⑤		6	12 3	48.4	
RCS2-SA6D-①-30-3-②-③-④-⑤		3	18 6	96.8	

Legend ① Encoder ② Stroke ③ Compatible controller ④ Cable length ⑤ Options

■ Stroke and Maximum Speed

Stroke / Lead	50 ~ 450 (50mm increments)	500 (mm)	550 (mm)	600 (mm)
12	800	760	640	540
6	400	380	320	270
3	200	190	160	135

(Unit: mm/s)

Encoder & Stroke List

② Stroke (mm)	Standard Price	
	① Encoder Type	
	Incremental	Absolute
50	I	A
100	-	-
150	-	-
200	-	-
250	-	-
300	-	-
350	-	-
400	-	-
450	-	-
500	-	-
550	-	-
600	-	-

⑤ Option List

Name	Option Code	See Page	Standard Price
Brake (Cable exiting end)	BE	→ A-25	—
Brake (Cable exiting left)	BL	→ A-25	—
Brake (Cable exiting right)	BR	→ A-25	—
Reversed-home	NM	→ A-33	—
Slider Roller	SR	→ A-36	—

④ Cable List

Type	Cable Symbol	Standard Price
Standard	P (1m)	—
	S (3m)	—
	M (5m)	—
Special Lengths	X06 (6m) ~ X10 (10m)	—
	X11 (11m) ~ X15 (15m)	—
	X16 (16m) ~ X20 (20m)	—
	R01 (1m) ~ R03 (3m)	—
Robot Cable	R04 (4m) ~ R05 (5m)	—
	R06 (6m) ~ R10 (10m)	—
	R11 (11m) ~ R15 (15m)	—
	R16 (16m) ~ R20 (20m)	—

* For cables for maintenance, see page A-39.

Actuator Specifications

Item	Description
Drive System	Ball screw Ø10mm C10 grade
Positioning Repeatability	±0.02mm
Lost Motion	0.1mm or less
Base	Material: Aluminum (white alumite treated)
Allowable Static Moment	Ma: 38.3N·m Mb: 54.7N·m Mc: 81.0N·m
Allowable Dynamic Moment (*)	Ma: 8.9 N·m Mb: 12.7 N·m Mc: 18.6 N·m
Overhang Load Length	Ma direction: 220mm or less Mb-Mc direction: 220mm or less
Ambient Operating Temp./Humidity	0 ~ 40°C, 85% RH or less (Non-condensing)

(*) Based on 5,000km travel life.

Directions of Allowable Load Moments

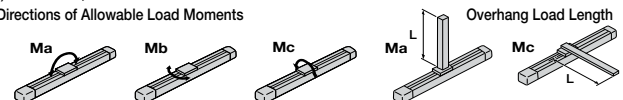

Dimensions

CAD drawings can be downloaded from IAI website. www.intelligentactuator.com

For Special Orders P. A-9

2D CAD

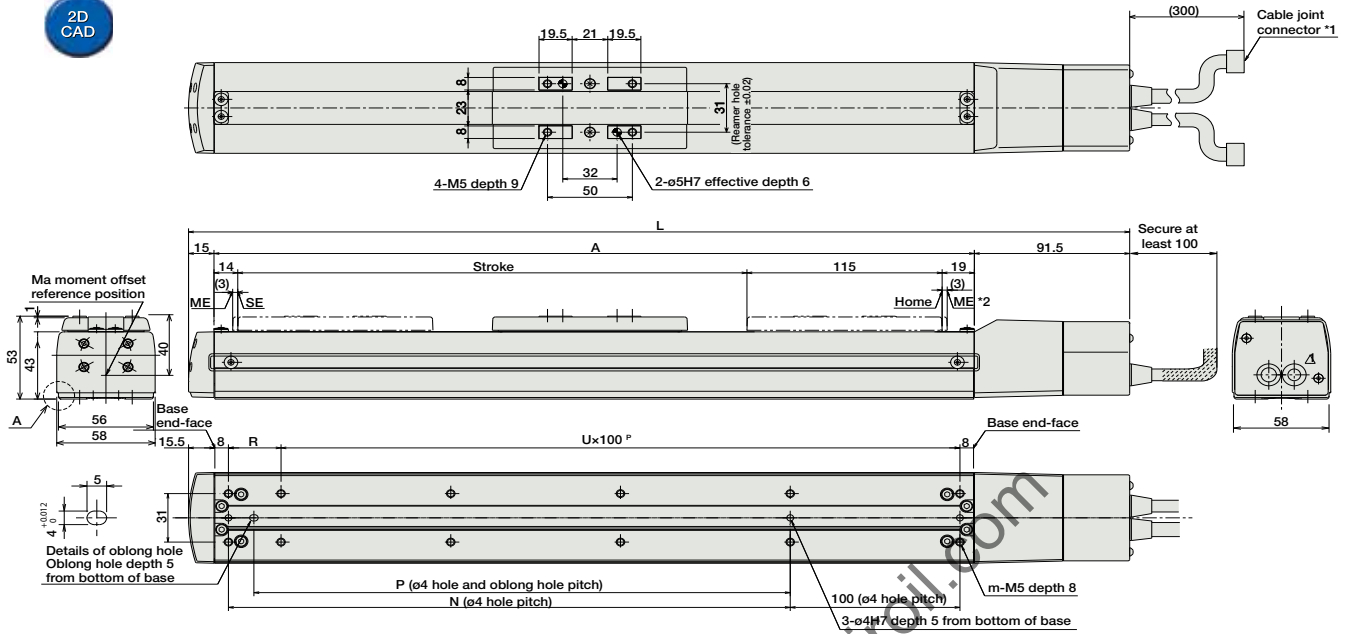

Dimensions of the Brake Section

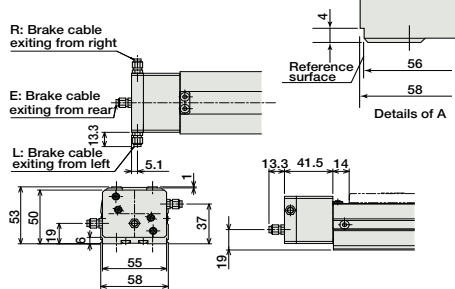

* Adding a brake increases the actuator's overall length (L) by 26.5mm (39.8mm with the cable coming out its end), and its weight by 0.3kg.

- *1 A motor-encoder cable is connected here. See page A-39 for details on cables.
 - *2 When homing, the slider moves to the ME; therefore, please watch for any interference with the surrounding objects.
 - *3 Reference position for calculating the moment Ma.
- ME: Mechanical end SE: Stroke end

Dimensions/Weight by Stroke

Stroke	50	100	150	200	250	300	350	400	450	500	550	600
L	304.5	354.5	404.5	454.5	504.5	554.5	604.5	654.5	704.5	754.5	804.5	854.5
A	198	248	298	348	398	448	498	548	598	648	698	748
N	81	131	181	231	281	331	381	431	481	531	581	631
P	66	116	166	216	266	316	366	416	466	516	566	616
R	81	31	81	31	81	31	81	31	81	31	81	31
U	1	2	2	3	3	4	4	5	5	6	6	7
m	6	8	8	10	10	12	12	14	14	16	16	18
Weight (kg)	1.3	1.5	1.7	1.9	2.1	2.3	2.5	2.7	2.9	3.1	3.3	3.5

3 Compatible Controllers

The RCS2 series actuators can operate with the controllers below. Select the controller according to your usage.

Name	External View	Model	Description	Max. Positioning Points	Input Voltage	Power Supply Capacity	Standard Price	See Page
Positioner Mode		SCON-C-30D①-NP-2-②	Positioning is possible for up to 512 points	512 points	Single-Phase AC 100V Single-Phase AC 200V 3-Phase AC 200V (XSEL-P/Q only)	360VA max. * When operating a 150W single-axis model	-	→ P547
Solenoid Valve Mode			Operable with same controls as solenoid valve.	7 points				
Serial Communication Type			Dedicated to serial communication	64 points				
Pulse Train Input Control Type			Dedicated to Pulse Train Input	(-)				
Program Control 1-2 Axis Type		SSEL-C-1-30D①-NP-2-②	Programmed operation is possible Can operate up to 2 axes	20000 points			-	→ P577
Program Control 1-6 Axis Type		XSEL-③-1-30D①-N1-EEE-2-④	Programmed operation is possible Can operate up to 6 axes	20000 points			-	→ P587

- * For SSEL and XSEL, only applicable to the single-axis model.
- * ① is a placeholder for the encoder type (I: incremental, A: absolute).
- * ② is a placeholder for the power supply voltage (1: 100V, 2: single-phase 200V, 3: 3-phase 200V).
- * ③ is a placeholder for the XSEL type name (J, K, P, or Q).
- * ④ is a placeholder for the power supply voltage (1: 100V, 2: single-phase 200V, 3: 3-phase 200V).

RCS2-SA4R

ROBO Cylinder Slider Type 40mm Width 200V Servo Motor Side Mounted Motor

■ Configuration: **RCS2** — **SA4R** — — **20** — — — — —

Series — Type — Encoder — Motor — Lead — Stroke — Compatible Controllers — Cable Length — Option

I : Incremental
A : Absolute

20: 20W Servo motor

10: 10mm
5: 5mm
2.5: 2.5mm

50: 50mm
400: 400mm (50mm pitch increments)

T1: XSEL-J/K
T2: SCON
SSEL
XSEL-P/Q

N : None
P : 1m
S : 3m
M : 5m
X : Custom Length
R : Robot Cable

See Options below
* Be sure to specify which side the motor is to be mounted (ML/MR).

* See page Pre-35 for explanation of each code that makes up the configuration name.



Technical References P. A-5

POINT
Notes on Selection

(1) When the stroke increases, the maximum speed will drop to prevent the ball screw from reaching the critical rotational speed. Use the actuator specification table below to check the maximum speed at the stroke you desire.

(2) The load capacity is based on operation at an acceleration of 0.3G (0.2G for the 2.5mm-lead model, or when used vertically). These values are the upper limits for the acceleration.

Pictured: Left-mounted motor model (ML).

Actuator Specifications

Lead and Load Capacity

Model	Motor Output (W)	Lead (mm)	Max. Load Capacity		Rated Thrust (N)	Stroke (mm)
			Horizontal (kg)	Vertical (kg)		
RCS2-SA4R-①-20-10-②-③-④-⑤	20	10	4	1	19.6	50 ~ 400 (50mm increments)
RCS2-SA4R-①-20-5-②-③-④-⑤		5	6	2.5	39.2	
RCS2-SA4R-①-20-2.5-②-③-④-⑤		2.5	8	4.5	78.4	

Stroke and Maximum Speed

Stroke Lead	50 ~ 400 (50mm increments)	
	Stroke	50 ~ 400 (50mm increments)
10	665	
5	330	
2.5	165	

Legend ① Encoder ② Stroke ③ Compatible controller ④ Cable length ⑤ Options (Unit: mm/s)

Encoder & Stroke List

② Stroke (mm)	Standard Price	
	① Encoder Type	
	Incremental	Absolute
50	I	A
100	-	-
150	-	-
200	-	-
250	-	-
300	-	-
350	-	-
400	-	-

④ Cable List

Type	Cable Symbol	Standard Price
Standard	P (1m)	—
	S (3m)	—
	M (5m)	—
Special Lengths	X06 (6m) ~ X10 (10m)	—
	X11 (11m) ~ X15 (15m)	—
	X16 (16m) ~ X20 (20m)	—
	R01 (1m) ~ R03 (3m)	—
Robot Cable	R04 (4m) ~ R05 (5m)	—
	R06 (6m) ~ R10 (10m)	—
	R11 (11m) ~ R15 (15m)	—
	R16 (16m) ~ R20 (20m)	—

* For cables for maintenance, see page A-39.

⑤ Option List

Name	Option Code	See Page	Standard Price
Brake	B	→ A-25	—
Home sensor	HS	→ A-32	—
Reversed-home	NM	→ A-33	—
Left-Mounted Motor (Standard)	ML	→ A-33	—
Right-Mounted Motor	MR	→ A-33	—
Slider Roller	SR	→ A-36	—
Slider spacer	SS	→ A-36	—

Actuator Specifications

Item	Description
Drive System	Ball screw Ø8mm C10 grade
Positioning Repeatability	±0.02mm
Lost Motion	0.1mm or less
Base	Material: Aluminum (white alumite treated)
Allowable Static Moment	Ma: 6.9N·m Mb: 9.9N·m Mc: 17.0N·m
Allowable Dynamic Moment (*)	Ma: 2.7N·m Mb: 3.9N·m Mc: 6.8N·m
Overhang Load Length	Ma direction: 120mm or less Mb-Mc direction: 120mm or less
Ambient Operating Temp./Humidity	0~40°C, 85% RH or less (Non-condensing)

(*) Based on 5,000km travel life.

Directions of Allowable Load Moments

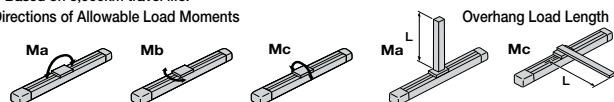

Dimensions

CAD drawings can be downloaded from IAI website. www.intelligentactuator.com

For Special Orders P. A-9

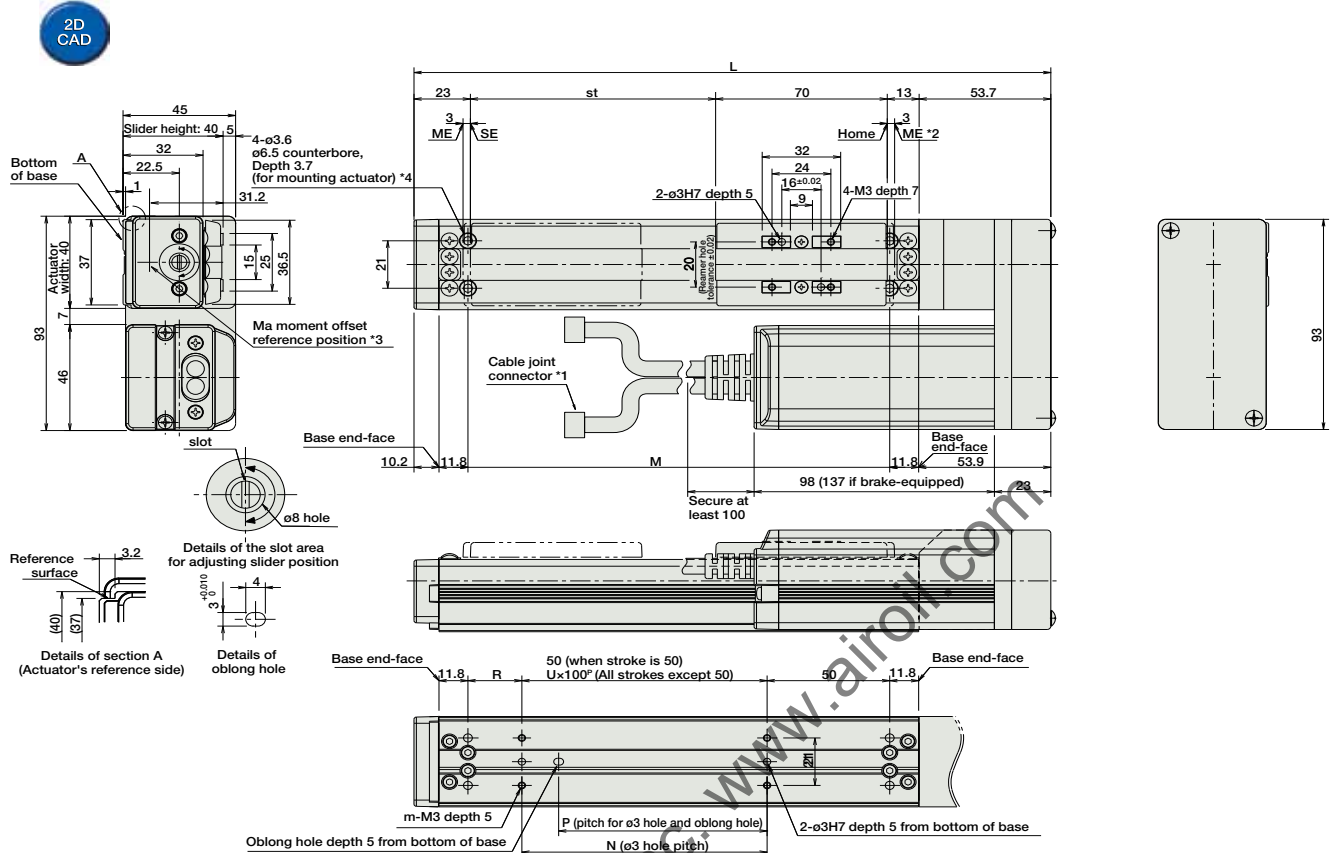

■ Dimensions/Weight by Stroke * Brake-equipped models are heavier by 0.3kg.

Stroke	50	100	150	200	250	300	350	400
L	209.7	259.7	309.7	359.7	409.7	459.7	509.7	559.7
M	122	172	222	272	322	372	422	472
N	50	100	100	200	200	300	300	400
P	35	85	85	185	185	285	285	385
R	22	22	72	22	72	22	72	22
U	-	1	1	2	2	3	3	4
m	4	4	4	6	6	8	8	10
Weight (kg)	0.8	0.9	1.0	1.1	1.2	1.3	1.4	1.5

- *1 The motor-encoder cable is connected here. See page A-39 for details on cables.
- *2 When homing, the slider moves to the ME; therefore, please watch for any interference with the surrounding objects.
ME: Mechanical end SE: Stroke end
- *3 Reference position for calculating the moment Ma.
- *4 If the actuator is secured using only the mounting holes provided on the top surface of the base, the base may twist to cause abnormal sliding of the slider, or may produce abnormal noise. Therefore, when using the mounting holes on the top surface of the base, keep the stroke at 200mm or less.

③ Compatible Controllers

The RCS2 series actuators can operate with the controllers below. Select the controller according to your usage.

Name	External View	Model	Description	Max. Positioning Points	Input Voltage	Power Supply Capacity	Standard Price	See Page
Positioner Mode		SCON-C-20①-NP-2-②	Positioning is possible for up to 512 points	512 points	Single-Phase AC 100V Single-Phase AC 200V 3-Phase AC 200V (XSEL-P/Q only)	360VA max. * When operating a 150W single-axis model	-	→ P547
Solenoid Valve Mode			Operable with same controls as solenoid valve.	7 points				
Serial Communication Type			Dedicated to serial communication	64 points				
Pulse Train Input Control Type			Dedicated to Pulse Train Input	(-)				
Program Control 1-2 Axis Type		SSEL-C-1-20①-NP-2-②	Programmed operation is possible. Can operate up to 2 axes	20000 points			-	→ P577
Program Control 1-6 Axis Type		XSEL-③-1-20①-N1-EEE-2-④	Programmed operation is possible. Can operate up to 6 axes	20000 points			-	→ P587

- * For SSEL and XSEL, only applicable to the single-axis model.
- * ① is a placeholder for the encoder type (I: incremental, A: absolute).
- * ② is a placeholder for the power supply voltage (1: 100V, 2: single-phase 200V, 3: 3-phase 200V).
- * ③ is a placeholder for the XSEL type name (J, K, F, or Q).
- * ④ is a placeholder for the power supply voltage (1: 100V, 2: single-phase 200V, 3: 3-phase 200V).

RCS2-SA5R

ROBO Cylinder Slider Type 52mm Width 200V Servo Motor Side Mounted Motor

■ Configuration: **RCS2** — **SA5R** — — **20** — — — — —

Series — Type — Encoder — Motor — Lead — Stroke — Compatible Controllers — Cable Length — Option

I : Incremental
A : Absolute

20: 20W Servo motor

12: 12mm
6: 6mm
3: 3mm

50: 50mm
500: 500mm (50mm pitch increments)

T1: XSEL-J/K
T2: SCON
SSEL
XSEL-P/Q

N : None
P : 1m
S : 3m
M : 5m
X : Custom Length
R : Robot Cable

See Options below
* Be sure to specify which side the motor is to be mounted (ML/MR).

* See page Pre-35 for explanation of each code that makes up the configuration name.

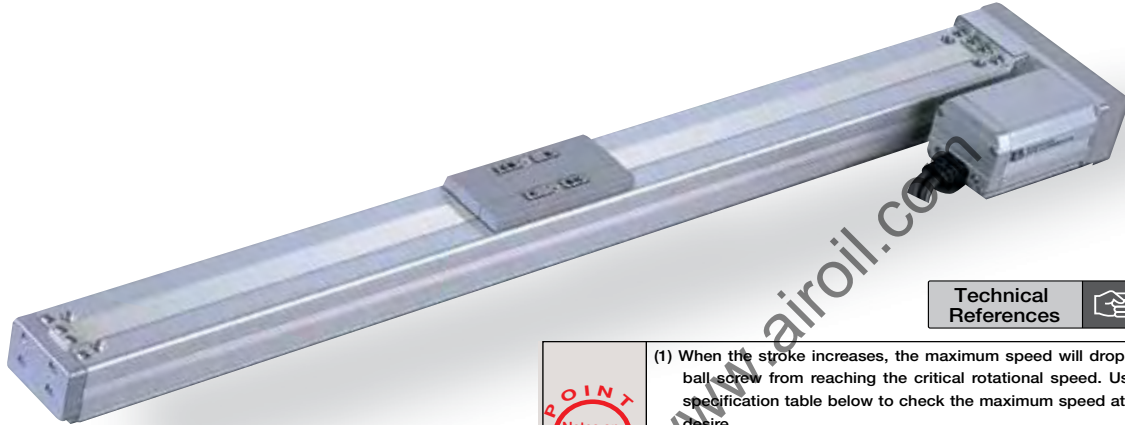

Technical References P. A-5

POINT
Notes on Selection

(1) When the stroke increases, the maximum speed will drop to prevent the ball screw from reaching the critical rotational speed. Use the actuator specification table below to check the maximum speed at the stroke you desire.

(2) The load capacity is based on operation at an acceleration of 0.3G (0.2G for the 3mm-lead model). These values are the upper limits for the acceleration.

Pictured: Left-mounted motor model (ML).

Actuator Specifications

Lead and Load Capacity

Model	Motor Output (W)	Lead (mm)	Max. Load Capacity		Rated Thrust (N)	Stroke (mm)
			Horizontal (kg)	Vertical (kg)		
RCS2-SA5R-①-20-12-②-③-④-⑤	20	12	4	1	16.7	50 ~ 500 (50mm increments)
RCS2-SA5R-①-20-6-②-③-④-⑤		6	8	2	33.3	
RCS2-SA5R-①-20-3-②-③-④-⑤		3	12	4	65.7	

Legend ① Encoder ② Stroke ③ Compatible controller ④ Cable length ⑤ Options

Stroke and Maximum Speed

Stroke Lead	50 ~ 450 (50mm increments)	500 (mm)
	12	800
6	400	380
3	200	190

(Unit: mm/s)

Encoder & Stroke List

② Stroke (mm)	Standard Price	
	① Encoder Type	
	Incremental	Absolute
50	I	A
100	-	-
150	-	-
200	-	-
250	-	-
300	-	-
350	-	-
400	-	-
450	-	-
500	-	-

④ Cable List

Type	Cable Symbol	Standard Price
Standard	P (1m)	—
	S (3m)	—
	M (5m)	—
Special Lengths	X06 (6m) ~ X10 (10m)	—
	X11 (11m) ~ X15 (15m)	—
	X16 (16m) ~ X20 (20m)	—
	R01 (1m) ~ R03 (3m)	—
Robot Cable	R04 (4m) ~ R05 (5m)	—
	R06 (6m) ~ R10 (10m)	—
	R11 (11m) ~ R15 (15m)	—
	R16 (16m) ~ R20 (20m)	—

* For cables for maintenance, see page A-39.

⑤ Option List

Name	Option Code	See Page	Standard Price
Brake	B	→ A-25	—
Home sensor	HS	→ A-32	—
Reversed-home	NM	→ A-33	—
Left-Mounted Motor (Standard)	ML	→ A-33	—
Right-Mounted Motor	MR	→ A-33	—
Slider Roller	SR	→ A-36	—

Actuator Specifications

Item	Description
Drive System	Ball screw Ø10mm C10 grade
Positioning Repeatability	±0.02mm
Lost Motion	0.1mm or less
Base	Material: Aluminum (white alumite treated)
Allowable Static Moment	Ma: 18.6N·m Mb: 26.6N·m Mc: 47.5N·m
Allowable Dynamic Moment (*)	Ma: 4.9N·m Mb: 6.8N·m Mc: 11.7N·m
Overhang Load Length	Ma direction: 150mm or less Mb-Mc direction: 150mm or less
Ambient Operating Temp./Humidity	0~40°C, 85% RH or less (Non-condensing)

(*) Based on 5,000km travel life.

Directions of Allowable Load Moments

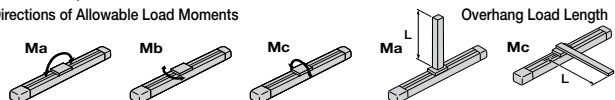

Dimensions

CAD drawings can be downloaded from IAI website. www.intelligentactuator.com

For Special Orders P. A-9

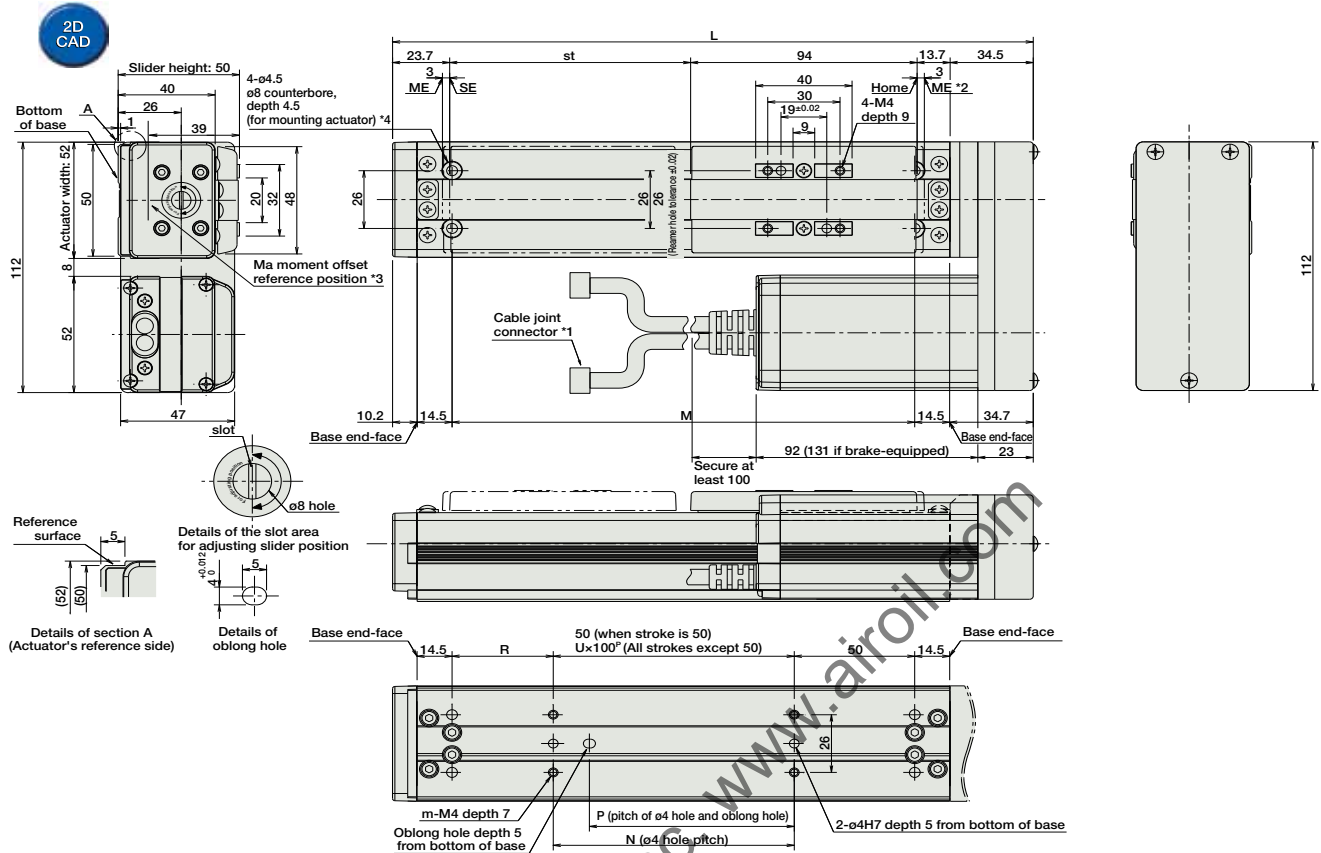

Dimensions/Weight by Stroke

* Brake-equipped models are heavier by 0.3kg.

Stroke	50	100	150	200	250	300	350	400	450	500
L	215.9	265.9	315.9	365.9	415.9	465.9	515.9	565.9	615.9	665.9
M	142	192	242	292	342	392	442	492	542	592
N	50	100	100	200	200	300	300	400	400	500
P	35	85	85	185	185	285	285	385	385	485
R	42	42	92	42	92	42	92	42	92	42
U	-	1	1	2	2	3	3	4	4	5
m	4	4	4	6	6	8	8	10	10	12
Weight (kg)	1.5	1.6	1.7	1.8	1.9	2.0	2.1	2.2	2.3	2.4

- *1 The motor-encoder cable is connected here. See page A-39 for details on cables.
- *2 When homing, the slider moves to the ME; therefore, please watch for any interference with the surrounding objects.
ME: Mechanical end SE: Stroke end
- *3 Reference position for calculating the moment Ma.
- *4 If the actuator is secured using only the mounting holes provided on the top surface of the base, the base may twist to cause abnormal sliding of the slider, or may produce abnormal noise. Therefore, when using the mounting holes on the top surface of the base, keep the stroke at 300mm or less.

3 Compatible Controllers

The RCS2 series actuators can operate with the controllers below. Select the controller according to your usage.

Name	External View	Model	Description	Max. Positioning Points	Input Voltage	Power Supply Capacity	Standard Price	See Page
Positioner Mode		SCON-C-20①-NP-2-②	Positioning is possible for up to 512 points	512 points	Single-Phase AC 100V Single-Phase AC 200V 3-Phase AC 200V (XSEL-P/Q only)	360VA max. * When operating a 150W single-axis model	-	→ P547
Solenoid Valve Mode			Operable with same controls as solenoid valve.	7 points				
Serial Communication Type			Dedicated to serial communication	64 points				
Pulse Train Input Control Type		SSEL-C-1-20①-NP-2-②	Dedicated to Pulse Train Input	(-)				
Program Control 1-2 Axis Type			Programmed operation is possible. Can operate up to 2 axes	20000 points				
Program Control 1-6 Axis Type		XSEL-③-1-20①-N1-EEE-2-④	Programmed operation is possible. Can operate up to 6 axes	20000 points				

- * For SSEL and XSEL, only applicable to the single-axis model.
- * ① is a placeholder for the encoder type (I: incremental, A: absolute).
- * ② is a placeholder for the power supply voltage (1: 100V, 2: single-phase 200V, 3: 3-phase 200V).
- * ③ is a placeholder for the XSEL type name (J, K, F, or Q).
- * ④ is a placeholder for the power supply voltage (1: 100V, 2: single-phase 200V, 3: 3-phase 200V).

RCS2-SA6R

ROBO Cylinder Slider Type 58mm Width 200V Servo Motor Side Mounted Motor

■ Configuration: **RCS2** — **SA6R** — — **30** — — — — —

Series — Type — Encoder — Motor — Lead — Stroke — Compatible Controllers — Cable Length — Option

I : Incremental
A : Absolute

30: 30W Servo motor

12: 12mm
6: 6mm
3: 3mm

50: 50mm
600: 600mm (50mm pitch increments)

T1: XSEL-J/K
T2: SCON
SSEL
XSEL-P/Q

N : None
P : 1m
S : 3m
M : 5m
X : Custom Length
R : Robot Cable

See Options below
* Be sure to specify which side the motor is to be mounted (ML/MR).

* See page Pre-35 for explanation of each code that makes up the configuration name.

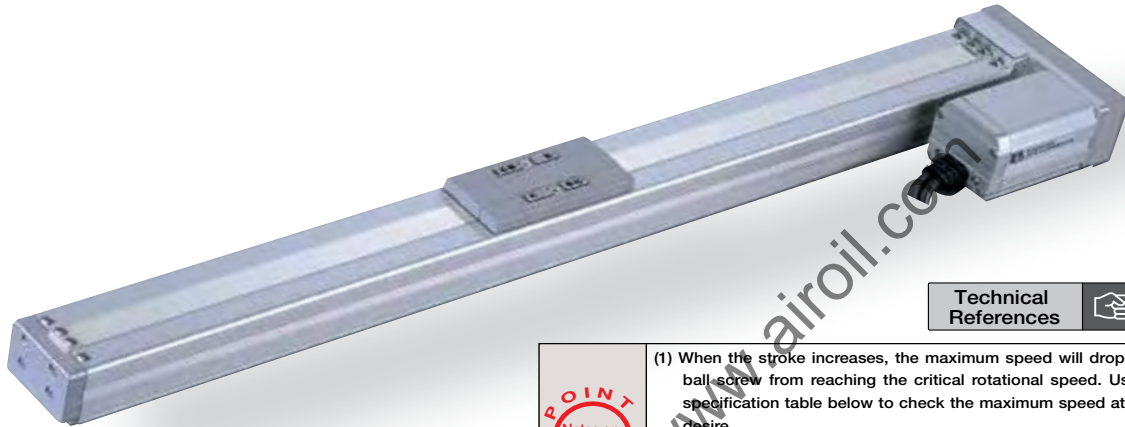

Technical References P. A-5

POINT
Notes on Selection

(1) When the stroke increases, the maximum speed will drop to prevent the ball screw from reaching the critical rotational speed. Use the actuator specification table below to check the maximum speed at the stroke you desire.

(2) The load capacity is based on operation at an acceleration of 0.3G (0.2G for the 3mm-lead model). These values are the upper limits for the acceleration.

Pictured: Left-mounted motor model (ML).

Actuator Specifications

Lead and Load Capacity

Model	Motor Output (W)	Lead (mm)	Max. Load Capacity		Rated Thrust (N)	Stroke (mm)
			Horizontal (kg)	Vertical (kg)		
RCS2-SA6R-①-30-12-②-③-④-⑤		12	6	1.5	24.2	50 ~ 600 (50mm increments)
RCS2-SA6R-①-30-6-②-③-④-⑤	30	6	12	3	48.4	
RCS2-SA6R-①-30-3-②-③-④-⑤		3	18	6	96.8	

Legend ① Encoder ② Stroke ③ Compatible controller ④ Cable length ⑤ Options

Stroke and Maximum Speed

Stroke Lead	Maximum Speed (mm/s)				
	50 ~ 450 (50mm increments)	500 (mm)	550 (mm)	600 (mm)	650 (mm)
12	800	760	640	540	
6	400	380	320	270	
3	200	190	160	135	

(Unit: mm/s)

Encoder & Stroke List

② Stroke (mm)	Standard Price	
	① Encoder Type	
	Incremental	Absolute
50	-	-
100	-	-
150	-	-
200	-	-
250	-	-
300	-	-
350	-	-
400	-	-
450	-	-
500	-	-
550	-	-
600	-	-

④ Cable List

Type	Cable Symbol	Standard Price
Standard	P (1m)	—
	S (3m)	—
	M (5m)	—
Special Lengths	X06 (6m) ~ X10 (10m)	—
	X11 (11m) ~ X15 (15m)	—
	X16 (16m) ~ X20 (20m)	—
	R01 (1m) ~ R03 (3m)	—
Robot Cable	R04 (4m) ~ R05 (5m)	—
	R06 (6m) ~ R10 (10m)	—
	R11 (11m) ~ R15 (15m)	—
	R16 (16m) ~ R20 (20m)	—

* For cables for maintenance, see page A-39.

⑤ Option List

Name	Option Code	See Page	Standard Price
Brake	B	→ A-25	—
Home sensor	HS	→ A-32	—
Reversed-home	NM	→ A-33	—
Left-Mounted Motor (Standard)	ML	→ A-33	—
Right-Mounted Motor	MR	→ A-33	—
Slider Roller	SR	→ A-36	—

Actuator Specifications

Item	Description
Drive System	Ball screw Ø10mm C10 grade
Positioning Repeatability	±0.02mm
Lost Motion	0.1mm or less
Base	Material: Aluminum (white alumite treated)
Allowable Static Moment	Ma: 38.3N·m Mb: 54.7N·m Mc: 81.0N·m
Allowable Dynamic Moment (*)	Ma: 8.9 N·m Mb: 12.7 N·m Mc: 18.6 N·m
Overhang Load Length	Ma direction: 220mm or less Mb-Mc direction: 220mm or less
Ambient Operating Temp./Humidity	0~40°C, 85% RH or less (Non-condensing)

(*) Based on 5,000km travel life.

Directions of Allowable Load Moments

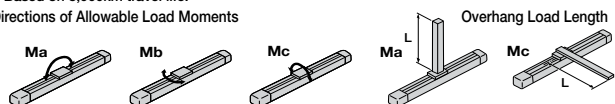

Dimensions

CAD drawings can be downloaded from IAI website. www.intelligentactuator.com

For Special Orders P. A-9

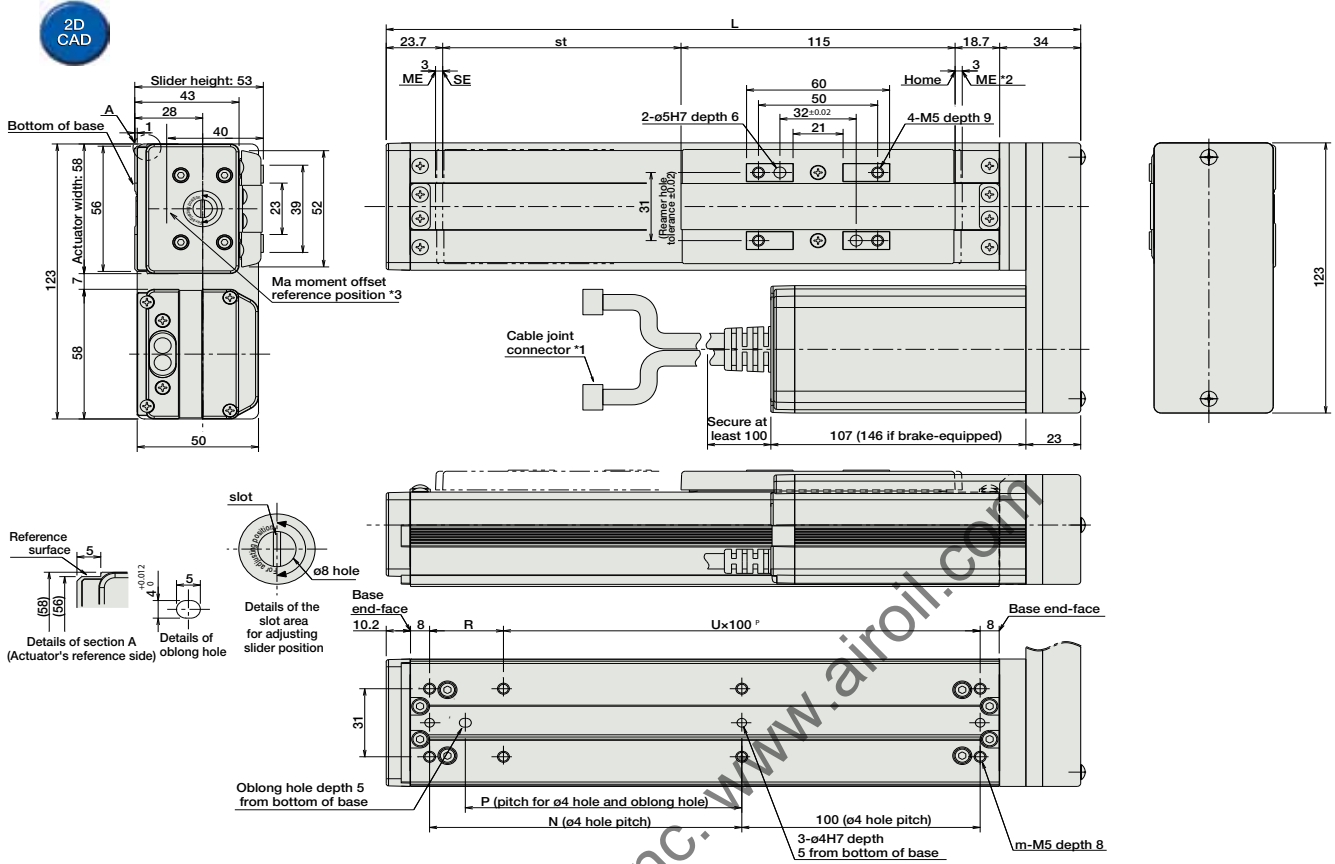

Dimensions/Weight by Stroke

* Brake-equipped models are heavier by 0.3kg.

Stroke	50	100	150	200	250	300	350	400	450	500	550	600
L	241.4	291.4	341.4	391.4	441.4	491.4	541.4	591.4	641.4	691.4	741.4	791.4
N	81	131	181	231	281	331	381	431	481	531	581	631
P	66	116	166	216	266	316	366	416	466	516	566	616
R	81	31	81	31	81	31	81	31	81	31	81	31
U	1	2	2	3	3	4	4	5	5	6	6	7
m	6	8	8	10	10	12	12	14	14	16	16	18
Weight (kg)	1.7	1.9	2.1	2.3	2.5	2.7	2.9	3.1	3.3	3.5	3.7	3.9

- *1 The motor-encoder cable is connected here. See page A-39 for details on cables.
- *2 When homing, the slider moves to the ME; therefore, please watch for any interference with the surrounding objects.
ME: Mechanical end SE: Stroke end
- *3 Reference position for calculating the moment Ma.

3 Compatible Controllers

The RCS2 series actuators can operate with the controllers below. Select the controller according to your usage.

Name	External View	Model	Description	Max. Positioning Points	Input Voltage	Power Supply Capacity	Standard Price	See Page
Positioner Mode		SCON-C-30D①-NP-2-②	Positioning is possible for up to 512 points	512 points	Single-Phase AC 100V Single-Phase AC 200V 3-Phase AC 200V (XSEL-P/Q only)	360VA max. * When operating a 150W single-axis model	-	→ P547
Solenoid Valve Mode			Operable with same controls as solenoid valve.	7 points				
Serial Communication Type			Dedicated to serial communication	64 points				
Pulse Train Input Control Type			Dedicated to Pulse Train Input	(-)				
Program Control 1-2 Axis Type		SSEL-C-1-30D①-NP-2-②	Programmed operation is possible Can operate up to 2 axes	20000 points			-	→ P577
Program Control 1-6 Axis Type		XSEL-③-1-30D①-N1-EEE-2-④	Programmed operation is possible Can operate up to 6 axes	20000 points			-	→ P587

- * For SSEL and XSEL, only applicable to the single-axis model.
- * ① is a placeholder for the encoder type (I: incremental, A: absolute).
- * ② is a placeholder for the power supply voltage (1: 100V, 2: single-phase 200V, 3: 3-phase 200V).
- * ③ is a placeholder for the XSEL type name (J, K, F, or Q).
- * ④ is a placeholder for the power supply voltage (1: 100V, 2: single-phase 200V, 3: 3-phase 200V).

RCS2-SA7R

ROBO Cylinder Slider Type 73mm Width 200V Servo Motor Side Mounted Motor

■ Configuration: **RCS2** — **SA7R** — — **60** — — — — —

Series — Type — Encoder — Motor — Lead — Stroke — Compatible Controllers — Cable Length — Option

I : Incremental
A : Absolute

60: 60W Servo motor

16: 16mm
8: 8mm
4: 4mm

50: 50mm
800: 800mm (50mm pitch increments)

T1: XSEL-J/K
T2: SCON
SSEL
XSEL-P/Q

N : None
P : 1m
S : 3m
M : 5m
X : Custom Length
R : Robot Cable

See Options below
* Be sure to specify which side the motor is to be mounted (ML/MR).

* See page Pre-35 for explanation of each code that makes up the configuration name.

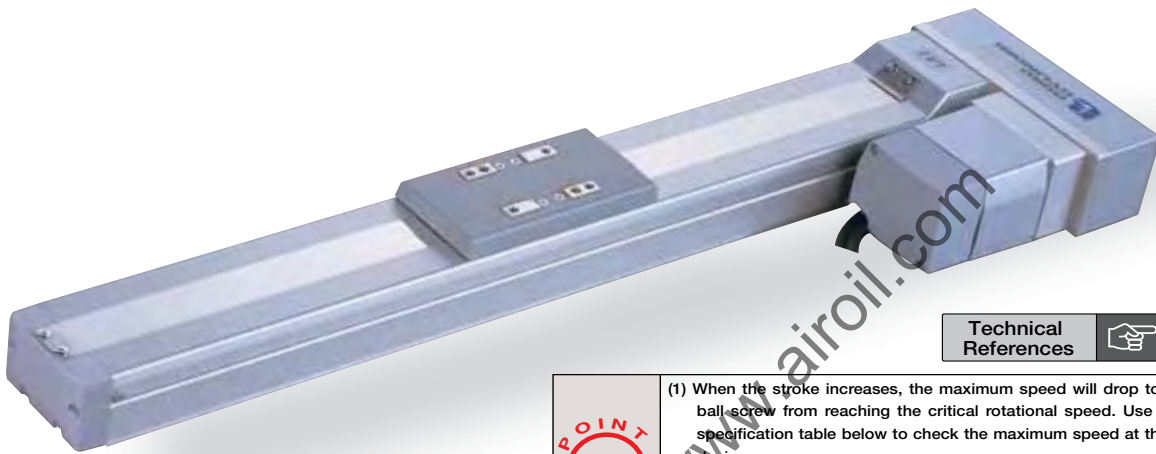

Technical References P. A-5

POINT
Notes on Selection

(1) When the stroke increases, the maximum speed will drop to prevent the ball screw from reaching the critical rotational speed. Use the actuator specification table below to check the maximum speed at the stroke you desire.

(2) The load capacity is based on operation at an acceleration of 0.3G (0.2G for 4mm-lead). These values are the upper limits for the acceleration.

Pictured: Left-mounted motor model (ML).

Actuator Specifications

Lead and Load Capacity

Model	Motor Output (W)	Lead (mm)	Max. Load Capacity		Rated Thrust (N)	Stroke (mm)
			Horizontal (kg)	Vertical (kg)		
RCS2-SA7R-①-60-16-②-③-④-⑤	60	16	12	3	63.8	50 ~ 800 (50mm increments)
RCS2-SA7R-①-60-8-②-③-④-⑤		8	25	6	127.5	
RCS2-SA7R-①-60-4-②-③-④-⑤		4	40	12	255.0	

Stroke and Maximum Speed

Stroke Lead	50 ~ 600 (50mm increments)	~ 700 (mm)	~ 800 (mm)
	16	800	640
8	400	320	240
4	200	160	120

(Unit: mm/s)

Legend ① Encoder ② Stroke ③ Compatible controller ④ Cable length ⑤ Options

Encoder & Stroke List

② Stroke (mm)	Standard Price	
	① Encoder Type	
	Incremental	Absolute
50/100	I	A
150/200	-	-
250/300	-	-
350/400	-	-
450/500	-	-
550/600	-	-
650/700	-	-
750/800	-	-

④ Cable List

Type	Cable Symbol	Standard Price
Standard	P (1m)	—
	S (3m)	—
	M (5m)	—
Special Lengths	X06 (6m) ~ X10 (10m)	—
	X11 (11m) ~ X15 (15m)	—
	X16 (16m) ~ X20 (20m)	—
	R01 (1m) ~ R03 (3m)	—
Robot Cable	R04 (4m) ~ R05 (5m)	—
	R06 (6m) ~ R10 (10m)	—
	R11 (11m) ~ R15 (15m)	—
	R16 (16m) ~ R20 (20m)	—

* For cables for maintenance, see page A-39.

⑤ Option List

Name	Option Code	See Page	Standard Price
Brake	B	→ A-25	—
Reversed-home	NM	→ A-33	—
Left-Mounted Motor (Standard)	ML	→ A-33	—
Right-Mounted Motor	MR	→ A-33	—
Slider Roller	SR	→ A-36	—

Actuator Specifications

Item	Description
Drive System	Ball screw ϕ 12mm C10 grade
Positioning Repeatability	\pm 0.02mm
Lost Motion	0.1mm or less
Base	Material: Aluminum (white alumite treated)
Allowable Static Moment	Ma: 50.4N·m Mb: 71.9N·m Mc: 138.0N·m
Allowable Dynamic Moment (*)	Ma: 13.9N·m Mb: 19.9N·m Mc: 38.3N·m
Overhang Load Length	Ma direction: 230mm or less Mb-Mc direction: 230mm or less
Ambient Operating Temp./Humidity	0~40°C, 85% RH or less (Non-condensing)

(*) Based on 5,000km travel life.

Directions of Allowable Load Moments

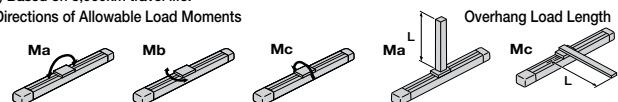

Dimensions

CAD drawings can be downloaded from IAI website. www.intelligentactuator.com

For Special Orders P. A-9



* The reference surface is the same as the SA7C type. (See P106)
 * The offset reference position for the moment Ma is the same as the SA7C type. (See P106)

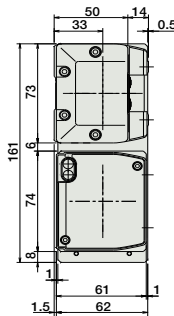

Dimensions of the Brake Section

* Adding a brake will increase the actuator's overall length by 43mm, and its weight by 0.6kg.

Mounting direction: symmetrically opposite

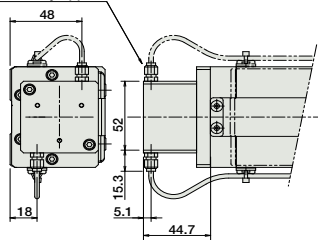

* For brake cable exiting from the side, it can only exit from the motor side.

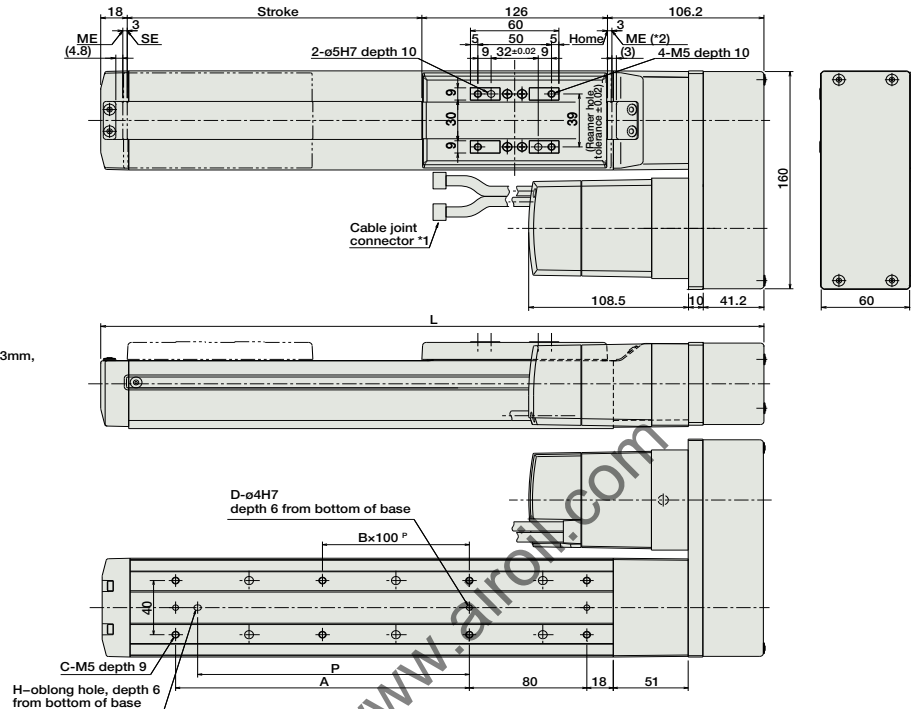
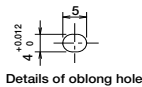

Memo:
 ME: Mechanical end, SE: Stroke end

■ Dimensions/Weight by Stroke

Stroke	50	100	150	200	250	300	350	400	450	500	550	600	650	700	750	800
L	300.2	350.2	400.2	450.2	500.2	550.2	600.2	650.2	700.2	750.2	800.2	850.2	900.2	950.2	1000.2	1050.2
A	0	100	100	200	200	300	300	400	400	500	500	600	600	700	700	800
B	0	0	0	1	1	2	2	3	3	4	4	5	5	6	6	7
C	4	6	6	8	8	10	10	12	12	14	14	16	16	18	18	20
D	2	3	3	3	3	3	3	3	3	3	3	3	3	3	3	3
H	0	1	1	1	1	1	1	1	1	1	1	1	1	1	1	1
P	0	85	85	185	185	285	285	385	385	485	485	585	585	685	685	785
Weight (kg)	4.0	4.2	4.4	4.6	4.9	5.1	5.3	5.5	5.8	6.0	6.2	6.4	6.7	6.9	7.1	7.3

*1 A motor-encoder cable is connected here. See page A-39 for details on cables.
 *2 When homing, the slider moves to the ME; therefore, please watch for any interference with the surrounding objects.
 ME: Mechanical end SE: Stroke end

③ Compatible Controllers

The RCS2 series actuators can operate with the controllers below. Select the controller according to your usage.

Name	External View	Model	Description	Max. Positioning Points	Input Voltage	Power Supply Capacity	Standard Price	See Page
Positioner Mode		SCON-C-60①-NP-2-②	Positioning is possible for up to 512 points	512 points	Single-Phase AC 100V Single-Phase AC 200V 3-Phase AC 200V (XSEL-P/Q only)	360VA max. * When operating a 150W single-axis model	-	→ P547
Solenoid Valve Mode			Operable with same controls as solenoid valve.	7 points				
Serial Communication Type			Dedicated to serial communication	64 points				
Pulse Train Input Control Type			Dedicated to Pulse Train Input	(-)				
Program Control 1-2 Axis Type		SSEL-C-1-60①-NP-2-①	Programmed operation is possible Can operate up to 2 axes	20000 points			-	→ P577
Program Control 1-6 Axis Type		XSEL-③-1-60①-N1-EEE-2-④	Programmed operation is possible Can operate up to 6 axes	20000 points			-	→ P587

* For SSEL and XSEL, only applicable to the single-axis model.
 * ① is a placeholder for the encoder type (I: incremental, A: absolute).
 * ② is a placeholder for the power supply voltage (1: 100V, 2: single-phase 200V, 3: 3-phase 200V).
 * ③ is a placeholder for the XSEL type name (J, K, P, or Q).
 * ④ is a placeholder for the power supply voltage (1: 100V, 2: single-phase 200V, 3: 3-phase 200V).

- Slider Type
- Mini
- Standard
- Controllers Integrated
- Rod Type
- Mini
- Standard
- Controllers Integrated
- Table/Arm/Flat Type
- Mini
- Standard
- Gripper/Rotary Type
- Linear Servo Type
- Cleanroom Type
- Splash-Proof
- Controllers
- PMEC /AMEC
- PSEP /ASEP
- ROBO NET
- ERC2
- PCON
- ACON
- SCON
- PSEL
- ASEL
- SSEL
- XSEL
- Pulse Motor
- Servo Motor (24V)
- Servo Motor (200V)
- Linear Servo Motor

RCS2-SS7R

ROBO Cylinder Slider Type 60mm Width 200V Servo Motor
Side Mounted Motor Steel Base

■ Configuration: **RCS2** — **SS7R** — — **60** — — — —

Series	Type	Encoder	Motor	Lead	Stroke	Compatible Controllers	Cable Length	Option
I : Incremental A : Absolute	60: 60W Servo motor	12: 12mm 6: 6mm	50: 50mm 600: 600mm (50mm pitch increments)	T1: XSEL-J/K T2: SCON SSEL XSEL-P/Q	N : None P : 1m S : 3m M : 5m X <input type="checkbox"/> : Custom Length R <input type="checkbox"/> : Robot Cable	See Options below * Be sure to specify which side the motor is to be mounted (ML/MR).		

* See page Pre-35 for explanation of each code that makes up the configuration name.

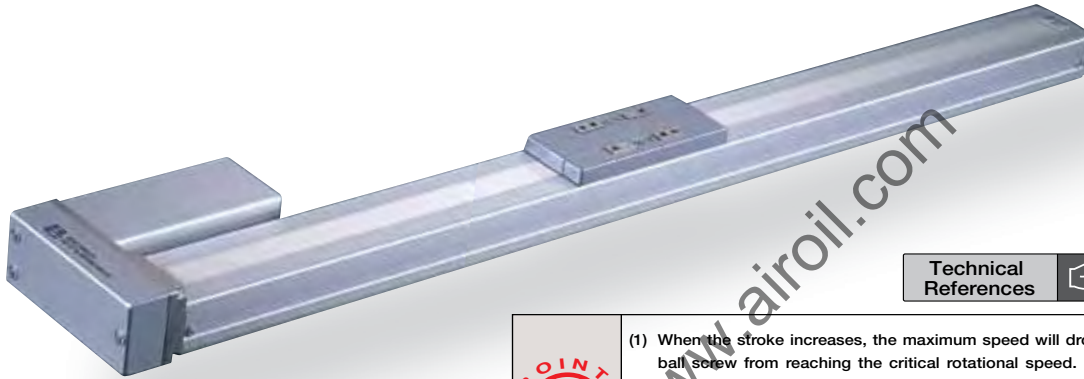

Pictured: Left-mounted motor model (ML).

Technical References P. A-5

POINT Notes on Selection

(1) When the stroke increases, the maximum speed will drop to prevent the ball screw from reaching the critical rotational speed. Use the actuator specification table below to check the maximum speed at the stroke you desire.

(2) The load capacity is based on operation at an acceleration of 0.3G. These values are the upper limits for the acceleration.

Actuator Specifications

■ Lead and Load Capacity

Model	Motor Output (W)	Lead (mm)	Max. Load Capacity		Rated Thrust (N)	Stroke (mm)
			Horizontal (kg)	Vertical (kg)		
RCS2-SS7R-①-60-12-②-③-④-⑤	60	12	15	4	85	50 ~ 600 (50mm increments)
RCS2-SS7R-①-60-6-②-③-④-⑤		6	30	8	170	

■ Stroke and Maximum Speed

Stroke Lead	50 ~ 500 (50mm increments)	~ 600 (mm)
	12	600
6	300	230

Legend ① Encoder ② Stroke ③ Compatible controller ④ Cable length ⑤ Options (Unit: mm/s)

Encoder & Stroke List

② Stroke (mm)	Standard Price	
	① Encoder Type	
	Incremental	Absolute
50/100	I	A
150/200	-	-
250/300	-	-
350/400	-	-
450/500	-	-
550/600	-	-

④ Cable List

Type	Cable Symbol	Standard Price
Standard	P (1m)	—
	S (3m)	—
	M (5m)	—
Special Lengths	X06 (6m) ~ X10 (10m)	—
	X11 (11m) ~ X15 (15m)	—
	X16 (16m) ~ X20 (20m)	—
	X21 (21m) ~ X25 (25m)	—
Robot Cable	R01 (1m) ~ R03 (3m)	—
	R04 (4m) ~ R05 (5m)	—
	R06 (6m) ~ R10 (10m)	—
	R11 (11m) ~ R15 (15m)	—
	R16 (16m) ~ R20 (20m)	—

* For cables for maintenance, see page A-39.

⑤ Option List

Name	Option Code	See Page	Standard Price
Brake	B	→ A-25	—
Reversed-home	NM	→ A-33	—
Left-Mounted Motor (Standard)	ML	→ A-33	—
Right-Mounted Motor	MR	→ A-33	—
Slider Roller	SR	→ A-36	—

Actuator Specifications

Item	Description
Drive System	Ball screw Ø10mm C10 grade
Positioning Repeatability	±0.02mm
Lost Motion	0.1mm or less
Base	Material: Special alloy steel
Allowable Static Moment	Ma: 79.4N·m Mb: 79.4N·m Mc: 172.9N·m
Allowable Dynamic Moment (*)	Ma: 14.7N·m Mb: 14.7N·m Mc: 33.3N·m
Overhang Load Length	Ma direction: 300mm or less Mb-Mc direction: 300mm or less
Ambient Operating Temp./Humidity	0~40°C, 85% RH or less (Non-condensing)

(*) Based on 10,000km travel life.

Directions of Allowable Load Moments

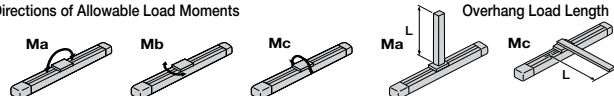

Dimensions

CAD drawings can be downloaded from IAI website. www.intelligentactuator.com

For Special Orders P. A-9



*The reference surface is the same as the SS7C type. (See P108)
 *The offset reference position for the moment Ma is the same as the SS7C type. (See P108)

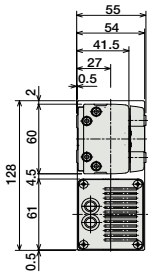

* Note that in order to change the home orientation, arrangements must be made to send in the product to IAI.
 * For the reversed-home model, the dimensions (distance from the ME to home) on the motor-side and that on the opposite side are flipped.

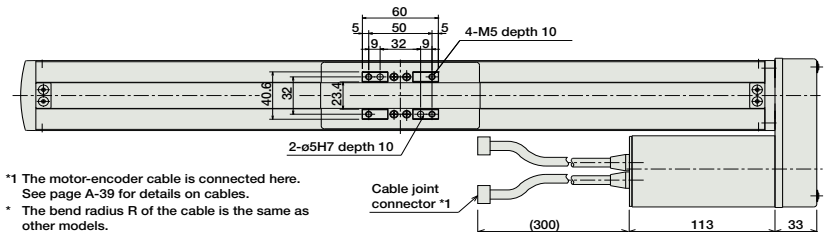

*1 The motor-encoder cable is connected here. See page A-39 for details on cables.
 * The bend radius R of the cable is the same as other models.

*2 When homing, the slider moves to the ME; therefore, please watch for any interference with the surrounding objects. SE: Stroke end ME: Mechanical end

* Adding a brake increases the actuator's overall length by 24.5mm and its weight by 0.3kg.

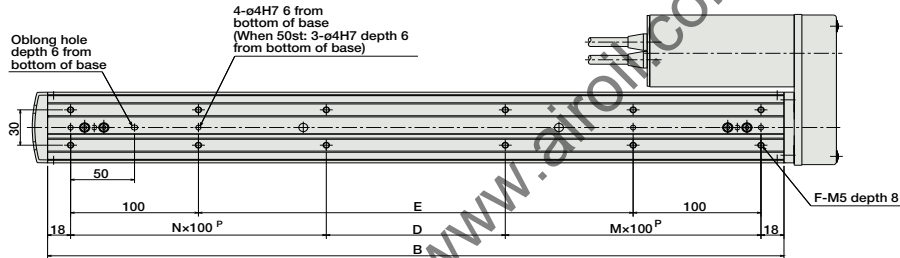
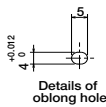

Dimensions of the Brake Section

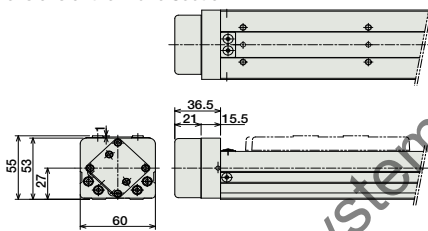

Dimensions/Weight by Stroke

Stroke	50	100	150	200	250	300	350	400	450	500	550	600
A	279	329	379	429	479	529	579	629	679	729	779	829
B	226	276	326	376	426	476	526	576	626	676	726	776
C	50	100	150	200	250	300	350	400	450	500	550	600
D	90	40	90	140	190	40	90	140	190	40	90	140
E	0	40	90	140	190	240	290	340	390	440	490	540
F	6	8	8	8	8	12	12	12	12	16	16	16
M	1	1	1	1	1	2	2	2	2	3	3	3
N	0	1	1	1	1	2	2	2	2	3	3	3
Weight (kg)	3.7	4.0	4.3	4.6	4.9	5.2	5.5	5.8	6.1	6.4	6.7	7.0

③ Compatible Controllers

The RCS2 series actuators can operate with the controllers below. Select the controller according to your usage.

Name	External View	Model	Description	Max. Positioning Points	Input Voltage	Power Supply Capacity	Standard Price	See Page
Positioner Mode		SCON-C-60①-NP-2-②	Positioning is possible for up to 512 points	512 points	Single-Phase AC 100V Single-Phase AC 200V 3-Phase AC 200V (XSEL-P/Q only)	360VA max. * When operating a 150W single-axis model	-	→P547
Solenoid Valve Mode			Operable with same controls as solenoid valve.	7 points				
Serial Communication Type			Dedicated to serial communication	64 points				
Pulse Train Input Control Type			Dedicated to Pulse Train Input	(-)				
Program Control 1-2 Axis Type		SSEL-C-1-60①-NP-2-②	Programmed operation is possible Can operate up to 2 axes	20000 points			-	→P577
Program Control 1-6 Axis Type		XSEL-③-1-60①-N1-EEE-2-④	Programmed operation is possible Can operate up to 6 axes	20000 points			-	→P587

* For SSEL and XSEL, only applicable to the single-axis model.
 * ① is a placeholder for the encoder type (I: incremental, A: absolute).
 * ② is a placeholder for the power supply voltage (1: 100V, 2: single-phase 200V, 3: 3-phase 200V).
 * ③ is a placeholder for the XSEL type name (J, K, P, or Q).
 * ④ is a placeholder for the power supply voltage (1: 100V, 2: single-phase 200V, 3: 3-phase 200V).

RCS2-SS8R

ROBO Cylinder Slider Type 80mm Width 200V Servo Motor
Side Mounted Motor Steel Base

■ Configuration: **RCS2** — **SS8R** — — — — — — — — —

Series — Type — Encoder — Motor — Lead — Stroke — Compatible Controllers — Cable Length — Option

I : Incremental
A : Absolute

100: 100W Servo motor
150: 150W Servo motor

20: 20mm
10: 10mm

50: 50mm
1000: 1000mm (50mm pitch increments)

T1: XSEL-J/K
T2: SCON
SSEL
XSEL-P/Q

N : None
P : 1m
S : 3m
M : 5m
X : Custom Length
R : Robot Cable

See Options below
* Be sure to specify which side the motor is to be mounted (ML/MR).

* See page Pre-35 for explanation of each code that makes up the configuration name.

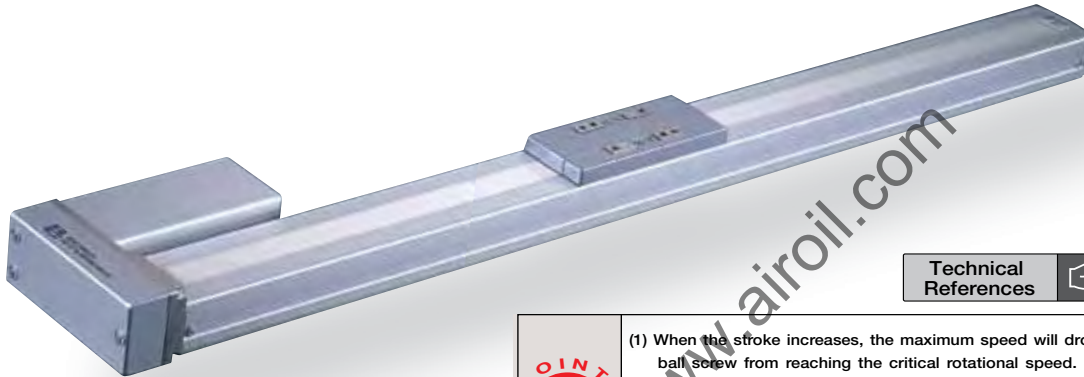

Technical References P. A-5

POINT
Notes on Selection

(1) When the stroke increases, the maximum speed will drop to prevent the ball screw from reaching the critical rotational speed. Use the actuator specification table below to check the maximum speed at the stroke you desire.

(2) The load capacity is based on operation at an acceleration of 0.3G. These values are the upper limits for the acceleration.

Pictured: Left-mounted motor model (ML).

Actuator Specifications

Lead and Load Capacity

Model	Motor Output	Lead (mm)	Max. Load Capacity Horizontal (kg) / Vertical (kg)	Rated Thrust (N)	Stroke (mm)
RCS2-SS8R-①-100-20-②-③-④-⑤	100	20	20 / 4	84.9	50 ~ 1000 (50mm increments)
RCS2-SS8R-①-100-10-②-③-④-⑤		10	40 / 8	169	
RCS2-SS8R-①-150-20-②-③-④-⑤	150	20	30 / 6	128	
RCS2-SS8R-①-150-10-②-③-④-⑥		10	60 / 12	256	

Legend ① Encoder ② Stroke ③ Compatible controller ④ Cable length ⑤ Options

Stroke and Maximum Speed

Stroke / Lead	50 ~ 600 (50mm increments)	~ 700 (mm)	~ 800 (mm)	~ 900 (mm)	~ 1000 (mm)
20	1000	960	765	625	515
10	500	480	380	310	255

(Unit: mm/s)

Encoder & Stroke List

② Stroke (mm)	Standard Price			
	① Encoder Type			
	Incremental		Absolute	
	Motor power output		Motor power output	
	100W	150W	100W	150W
50/100	-	-	-	-
150/200	-	-	-	-
250/300	-	-	-	-
350/400	-	-	-	-
450/500	-	-	-	-
550/600	-	-	-	-
650/700	-	-	-	-
750/800	-	-	-	-
850/900	-	-	-	-
950/1000	-	-	-	-

④ Cable List

Type	Cable Symbol	Standard Price
Standard	P (1m)	—
	S (3m)	—
	M (5m)	—
Special Lengths	X06 (6m) ~ X10 (10m)	—
	X11 (11m) ~ X15 (15m)	—
	X16 (16m) ~ X20 (20m)	—
	R01 (1m) ~ R03 (3m)	—
Robot Cable	R04 (4m) ~ R05 (5m)	—
	R06 (6m) ~ R10 (10m)	—
	R11 (11m) ~ R15 (15m)	—
	R16 (16m) ~ R20 (20m)	—

* For cables for maintenance, see page A-39.

⑤ Option List

Name	Option Code	See Page	Standard Price
Brake	B	→A-25	—
Reversed-home	NM	→A-33	—
Left-Mounted Motor (Standard)	ML	→A-33	—
Right-Mounted Motor	MR	→A-33	—
Slider Roller	SR	→A-36	—

Actuator Specifications

Item	Description
Drive System	Ball screw ø16mm C10 grade
Positioning Repeatability	±0.02mm
Lost Motion	0.1mm or less
Base	Material: Special alloy steel
Allowable Static Moment	Ma: 198.9N·m Mb: 198.9N·m Mc: 416.7N·m
Allowable Dynamic Moment (*)	Ma: 36.3N·m Mb: 36.3N·m Mc: 77.4N·m
Overhang Load Length	Ma direction: 450mm or less Mb-Mc direction: 450mm or less
Ambient Operating Temp./Humidity	0~40°C, 85% RH or less (Non-condensing)

(*) Based on 5,000km travel life.
Directions of Allowable Load Moments

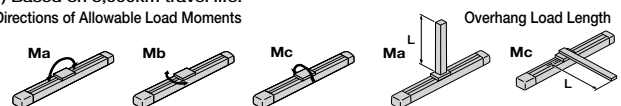

Dimensions

CAD drawings can be downloaded from IAI website. www.intelligentactuator.com

For Special Orders P. A-9

2D CAD

*The reference surface is the same as the SS8C type. (See P110)

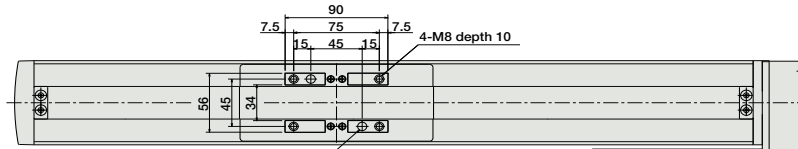
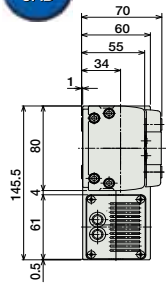

*1 The motor-encoder cable is connected here. See page A-39 for details on cables.
* The bend radius R of the cable is the same as other models.



*2 When homing, the slider moves to the ME; therefore, please watch for any interference with the surrounding objects. SE: Stroke end ME: Mechanical end

Dimensions of the Brake Section

* Adding a brake increases the actuator's overall length by 26mm and its weight by 0.5kg.

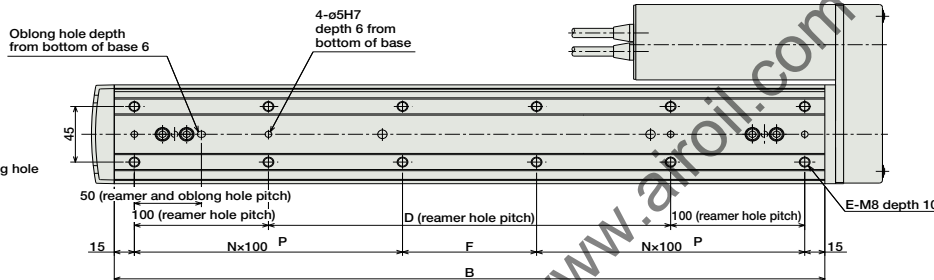
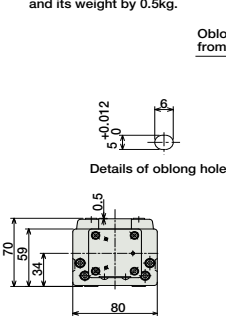

* The offset reference position for the moment Ma is the same as the SS8C type. (See P110)
* Note that in order to change the home orientation, arrangements must be made to send in the product to IAI.
* For the reversed-home model, the dimensions (distance from the ME to home) on the motor-side and that on the opposite side are flipped.

■ Dimensions/Weight by Stroke

Stroke	50	100	150	200	250	300	350	400	450	500	550	600	650	700	750	800	850	900	950	1000	
A	340	390	440	490	540	590	640	690	740	790	840	890	940	990	1040	1090	1140	1190	1240	1290	
B	280	330	380	430	480	530	580	630	680	730	780	830	880	930	980	1030	1080	1130	1180	1230	
C	50	100	150	200	250	300	350	400	450	500	550	600	650	700	750	800	850	900	950	1000	
D	50	100	150	200	250	300	350	400	450	500	550	600	650	700	750	800	850	900	950	1000	
E	8	8	8	10	12	12	12	14	16	16	16	18	20	20	20	22	24	24	24	26	26
F	50	100	150	0	50	100	150	0	50	100	150	0	50	100	150	0	50	100	150	0	
N	1	1	1	2	2	2	2	3	3	3	3	4	4	4	4	5	5	5	5	6	
Weight (kg)	6.7	7.2	7.7	8.2	8.7	9.2	9.7	10.2	10.7	11.2	11.7	12.2	12.7	13.2	13.7	14.2	14.7	15.2	15.7	16.2	

③ Compatible Controllers

The RCS2 series actuators can operate with the controllers below. Select the controller according to your usage.

Name	External View	Model	Description	Max. Positioning Points	Input Voltage	Power Supply Capacity	Standard Price	See Page
Positioner Mode		SCON-C-100①-NP-2-② SCON-C-150①-NP-2-②	Positioning is possible for up to 512 points	512 points	Single-Phase AC 100V Single-Phase AC 200V 3-Phase AC 200V (XSEL-P/Q only)	360VA max. * When operating a 150W single-axis model	-	→P547
Solenoid Valve Mode			Operable with same controls as solenoid valve.	7 points				
Serial Communication Type			Dedicated to serial communication	64 points				
Pulse Train Input Control Type			Dedicated to Pulse Train Input	(-)				
Program Control 1-2 Axis Type		SSEL-C-1-100①-NP-2-② SSEL-C-1-150-NP①-2-②	Programmed operation is possible Can operate up to 2 axes	20000 points			-	→P577
Program Control 1-6 Axis Type		XSEL-③-1-100①-N1-EEE-2-④ XSEL-③-1-150①-N1-EEE-2-④	Programmed operation is possible Can operate up to 6 axes	20000 points			-	→P587

* For SSEL and XSEL, only applicable to the single-axis model.
* ① is a placeholder for the encoder type (I: incremental, A: absolute).
* ② is a placeholder for the power supply voltage (1: 100V, 2: single-phase 200V, 3: 3-phase 200V).
* ③ is a placeholder for the XSEL type name (J, K, P, or Q).
* ④ is a placeholder for the power supply voltage (1: 100V, 2: single-phase 200V, 3: 3-phase 200V).