

**ROBO Cylinder**  
Motor-reversing Specification

# RCP3/RCA2

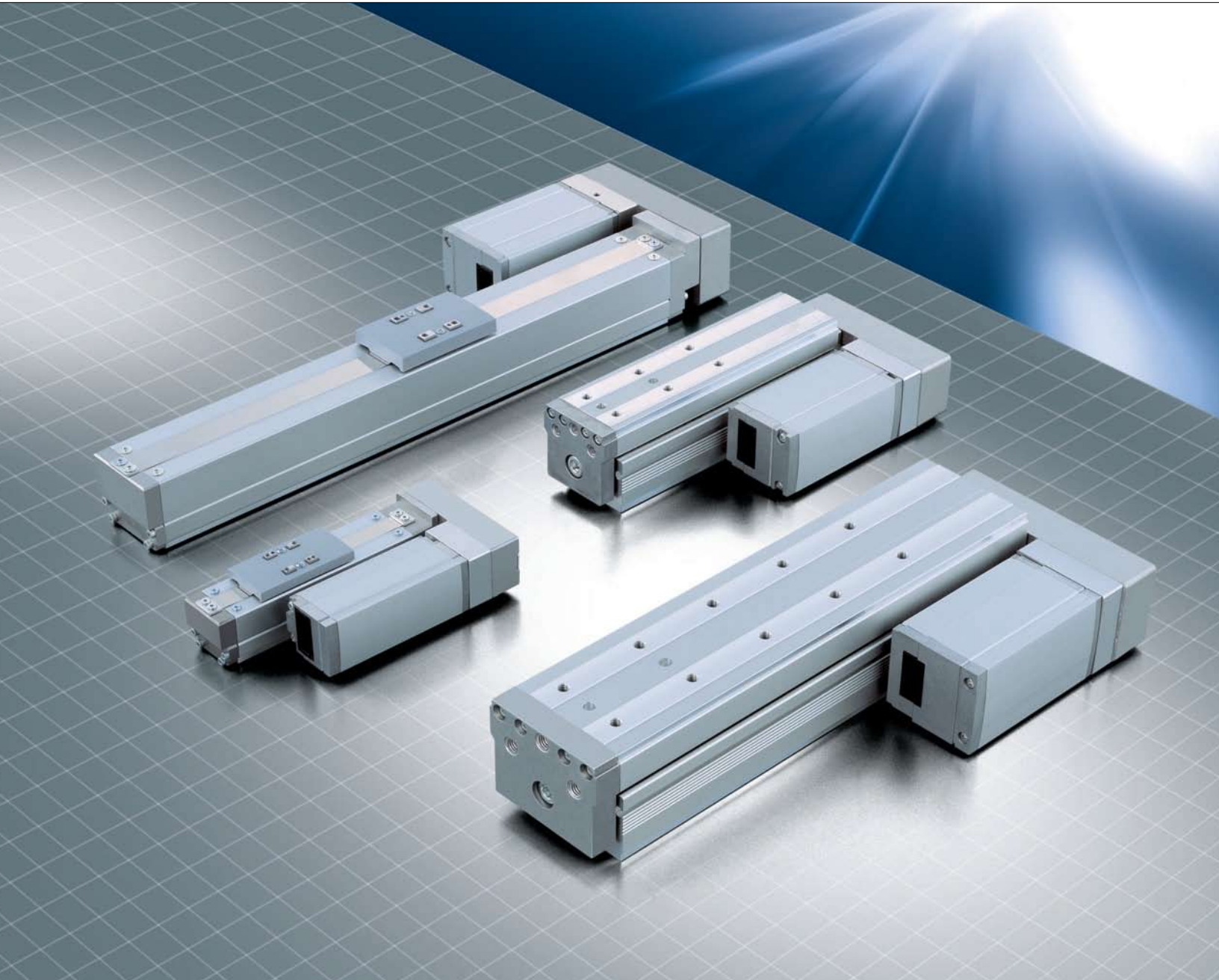

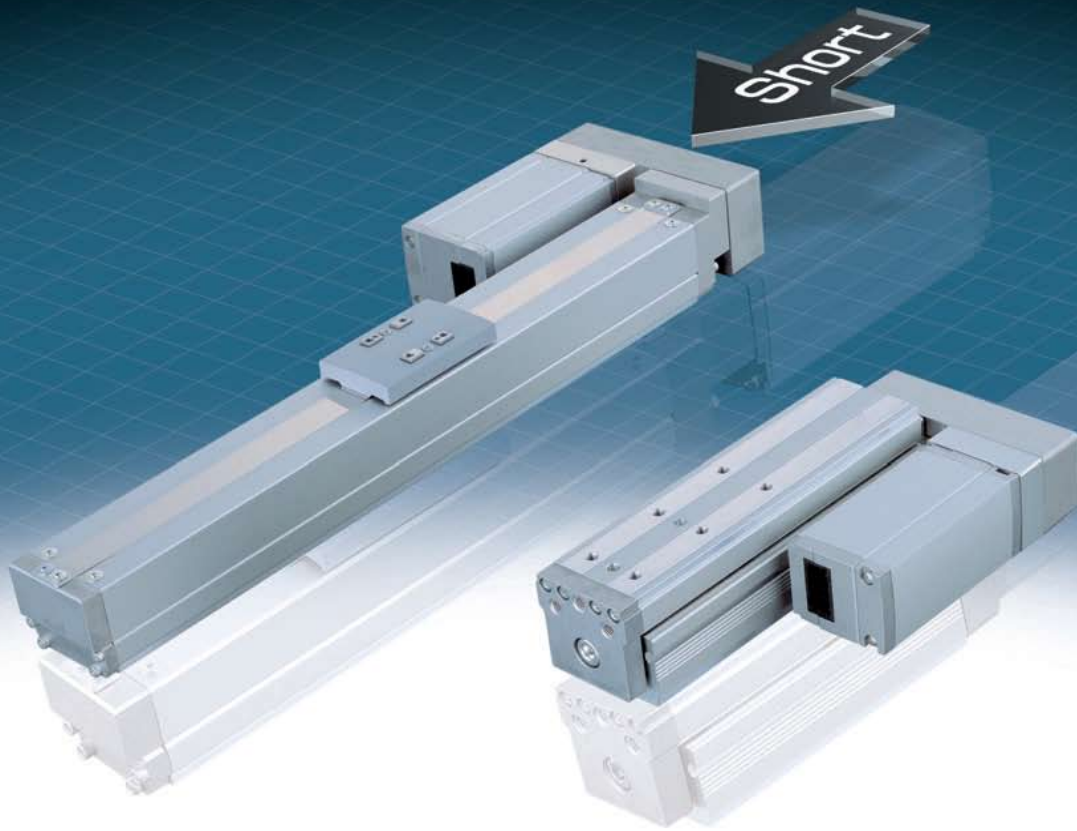

# Significantly Shorter Overall Length by Reversing the Motor Space-saving, Affordably Priced ROBO Cylinder RCP3/RCA2 Series

**Space-saving** The motor-reversing structure shortens the overall length by up to 85.5 mm.

1

The motor-reversing structure shortens the overall length by up to 85.5 mm and thereby reduces the actuator footprint. The motor-reversing direction can be selected from among the three options: right, left and downward\*

\*The downward-reversing specification is available as a customer order.

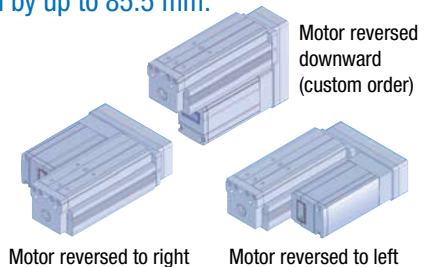
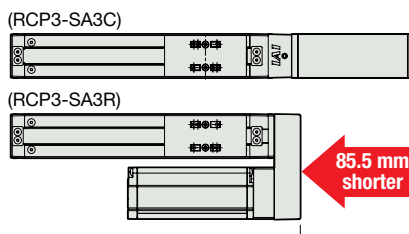

**Affordably Priced** The motor-reversing structure helps realize an affordable price.

2

The RCP3/RCA2 series, complete with the guide, ball screw, servo motor, and motor-reversing structure, is available at an affordable price. The slider type is also available without cover to further reduce the cost as an option.



Slider type/table type

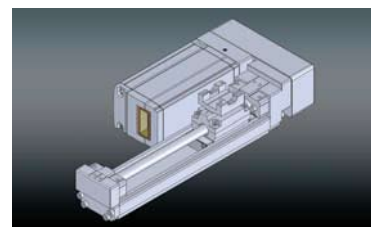

No cover type

**Easy to Use** The unitized motor design increases maintainability.

3

The unitized motor is easy to replace, which leads to significant improvement in maintainability.

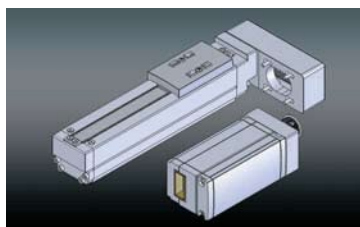

1

# Model Name Specifications

The model names of RCP3/RCA3 actuators consist of the items specified below.

For the details of each item, refer to the applicable explanation provided below. Although these items are common to all models, the selection ranges may vary depending on the model. For details, check the page explaining each actuator type.

## Slider Type

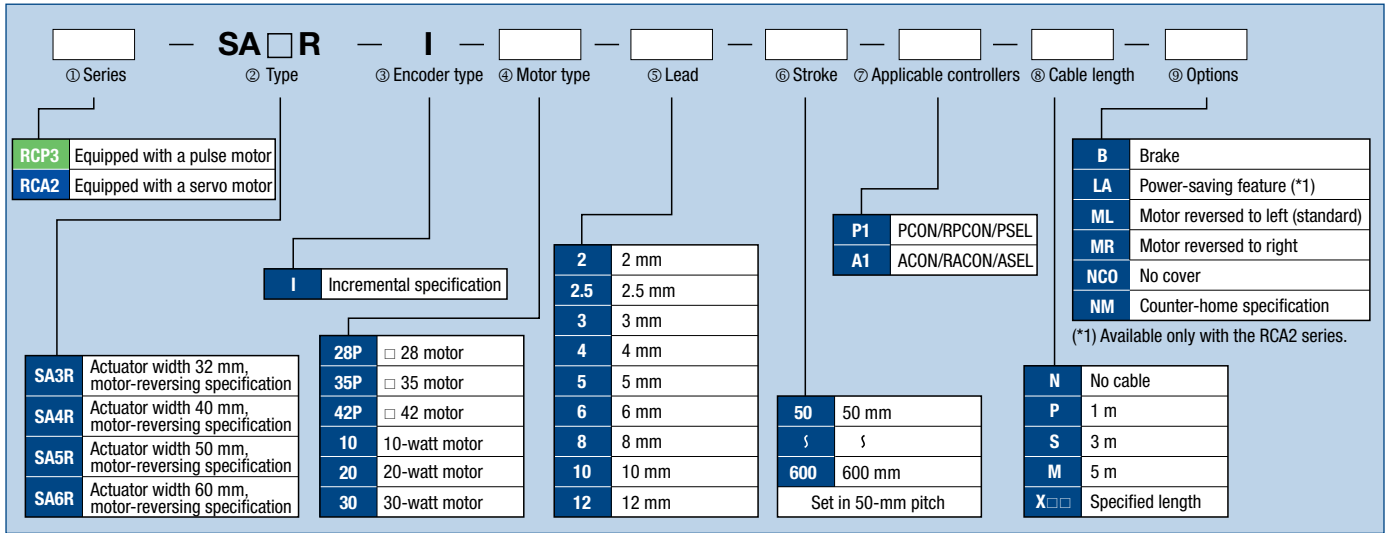

## Table Type

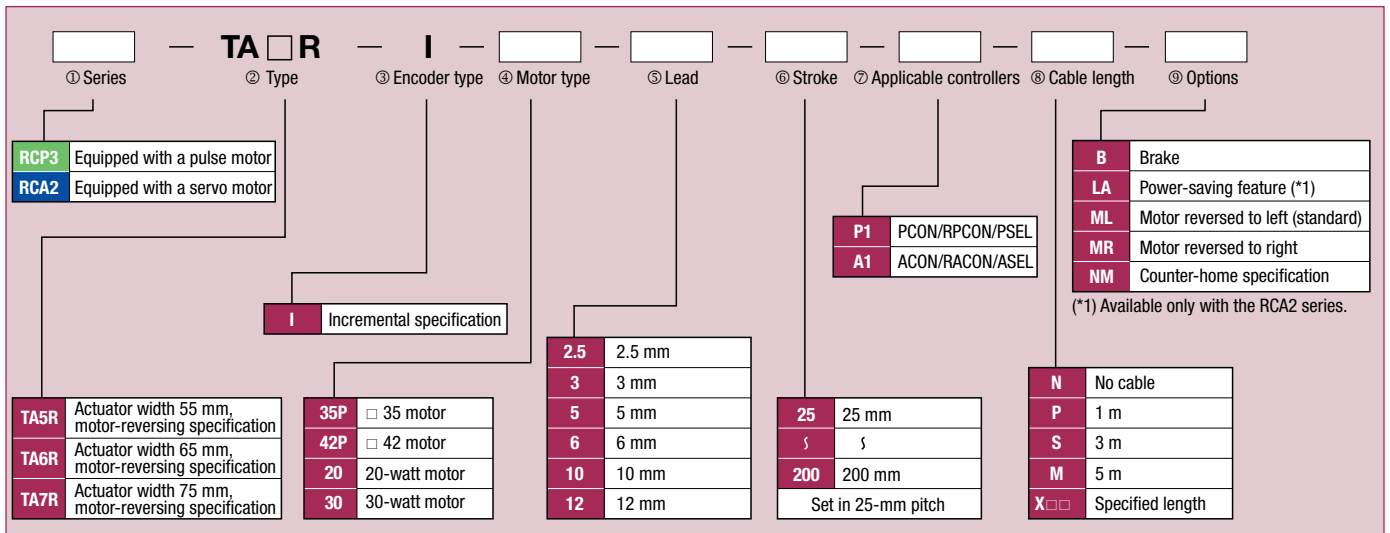

① Series

The name of each series is indicated.

② Type

The shape (slider, table, etc.), material (aluminum, steel, etc.), size (actuator width) and motor coupling method are indicated.

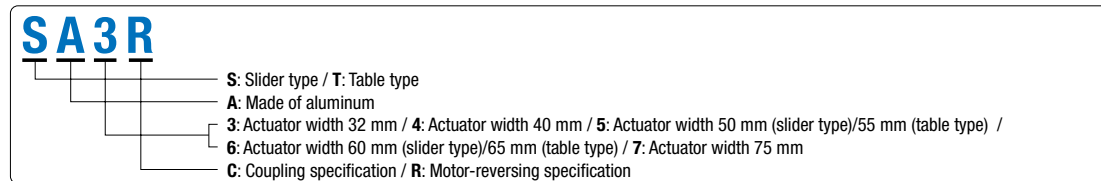

③ Encoder type

Whether the encoder installed in the actuator is of "A: Absolute specification" or "I: Incremental specification" is specified.

All RCP3/RCA2 models come with an incremental encoder.

④ Motor type

The type of the motor installed in the actuator is indicated.

To be specific, the size of the pulse motor is indicated for the RCP3 series, while the motor wattage is indicated for the RCA2 series.

⑤ Lead

The ball screw lead (distance traveled by the slider per each revolution of the ball screw) is indicated.

⑥ Stroke

The operating range of the actuator is indicated.

⑦ Applicable controllers

The settable controller type is indicated.

⑧ Cable length

The length of the (integrated) motor/encoder cable connecting the actuator and controller is indicated.

The standard motor/encoder cable for RCP2/RCA2 is a robot cable.

⑨ Options

Each option to be installed in the actuator is indicated.

The energy-saving feature is available only with the RCA2 series.

The standard motor-reversing direction is left (ML), but the actuator can also be designed so that the motor reverses to right (MR).

(Specify "ML" even when the standard reversing direction (left) need not be changed.)

If you are selecting two or more options, specify them in an alphabetical order.



# RCP3-SA3R ROBO Cylinder, Slider Type, Actuator Width 32 mm, Pulse Motor, Motor-reversing Specification

Model Name	<b>RCP3-SA3R</b>	<b>I</b>	<b>28P</b>	<input type="checkbox"/>	<input type="checkbox"/>	<b>P1</b>	<input type="checkbox"/>	<input type="checkbox"/>	
Specifications	Series	Type	Encoder type	Motor type	Lead	Stroke	Applicable controllers	Cable length	Options
			I: Incremental specification	28P: Pulse motor <input type="checkbox"/> 28 size	6:6 mm 4:4 mm 2:2 mm	50:50 mm 300:300 mm (Set in 50-mm pitch)	P1: PCON PSEL	N: None P: 1 m S: 3 m M: 5 m X <input type="checkbox"/> <input type="checkbox"/> : Specified length	B: With brake ML: Motor reversed to left (standard) MR: Motor reversed to right NCO: No cover NM: Counter-home specification

\*For details on the items comprising the model name, refer to P. 2.

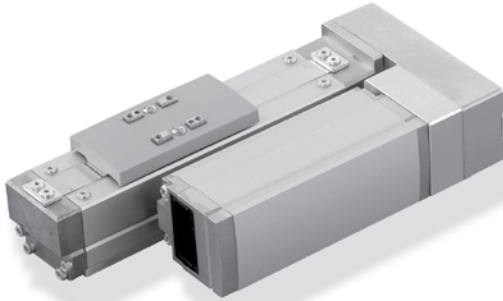

- Since the RCP3 series uses a pulse motor, its load capacity drops as the speed increases. Use the correlation diagrams of speed and load capacity provided on the right to check the load capacity achieved at the desired speed.
- The load capacities are based on operation at an acceleration of 0.3 G (or 0.2 G when the lead is 2 or the actuator is used vertically). The acceleration cannot be increased beyond this level.

**Correlation Diagrams of Speed and Load Capacity**  
Due to the characteristics of the pulse motor installed inside, the RCP3 series allows the load capacity to drop as the speed increases. Use the graphs below to check if the desired speed and load capacity can be satisfied.

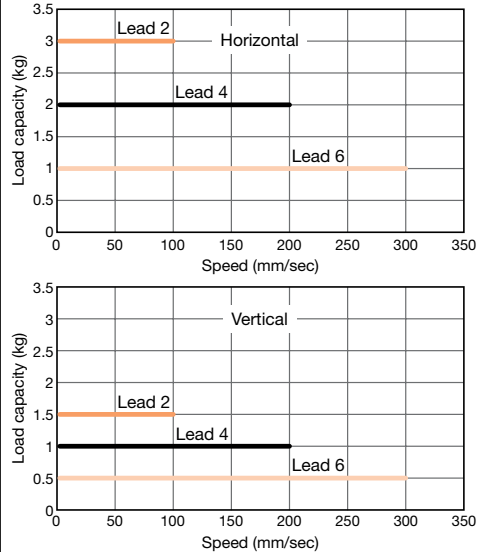

### Actuator Specifications

#### Strokes and Maximum Speeds

Model	Lead (mm)	Maximum load capacity		Maximum push force (N)	Stroke (mm)
		Horizontal (kg)	Vertical (kg)		
RCP3-SA3R-I-28P-6-①-P1-②-③	6	1	0.5	15	50 ~ 300 (Set in 50-mm pitch)
RCP3-SA3R-I-28P-4-①-P1-②-③	4	2	1	22	
RCP3-SA3R-I-28P-2-①-P1-②-③	2	3	1.5	44	

Explanation of codes: ① Stroke ② Cable length ③ Options

#### Strokes and Maximum Speeds

Stroke (mm)	Lead (mm)	50 ~ 300
		(Set in 50-mm pitch)
6	6	300
4	4	200
2	2	100

(Unit: mm/sec)

#### ① Price List by Stroke (Standard Prices)

① Stroke (mm)	Type code	
	SA3R	
	Encoder type	
	Incremental	
	Actuator cover	
	With cover (standard)	No cover (optional)
50	—	—
100	—	—
150	—	—
200	—	—
250	—	—
300	—	—

#### ② Price List by Cable Length (Standard Prices)

Type	Model	Standard price
Standard type (robot cable)	P (1m)	—
	S (3m)	—
	M (5m)	—
Special length	X06 (6m) ~ X10 (10m)	—
	X11 (11m) ~ X15 (15m)	—
	X16 (16m) ~ X20 (20m)	—
	—	—

\*The standard cable is an integrated motor/encoder cable, which is also a robot cable.  
\*Refer to P. 34 for the cables sold separately for maintenance purposes.

#### ③ Price List of Options (Standard Prices)

Name	Option code	Reference page	Standard price
With brake	B	—	—
Motor reversed to left (standard)	ML	—	Free of charge
Motor reversed to right	MR	—	Free of charge
No cover	NCO	—	See above.
Counter-home specification	NM	—	Free of charge

#### Actuator Specifications

Item	Description
Drive method	Ball screw, φ6 mm, rolled C10
Positioning repeatability	±0.05mm
Lost motion	0.1 mm or less
Base	Material: Aluminum with dedicated alumite treatment
Dynamic allowable load moment (*1)	Ma: 1.96N·m Mb: 2.84N·m Mc: 3.14N·m
Overhang load length	100 mm or less
Surrounding air temperature/humidity	0 to 40°C, 85%RH or below (non-condensing)
Traveling life	5000km

(\*1) Refer to the RCP3/RCA2 Coupling Specification catalog for the moment load calculation.

Directions of allowable load moments

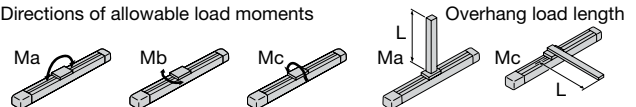

## Dimensions

CAD drawings can be downloaded from our website. [www.intelligentactuator.com](http://www.intelligentactuator.com)

2D CAD

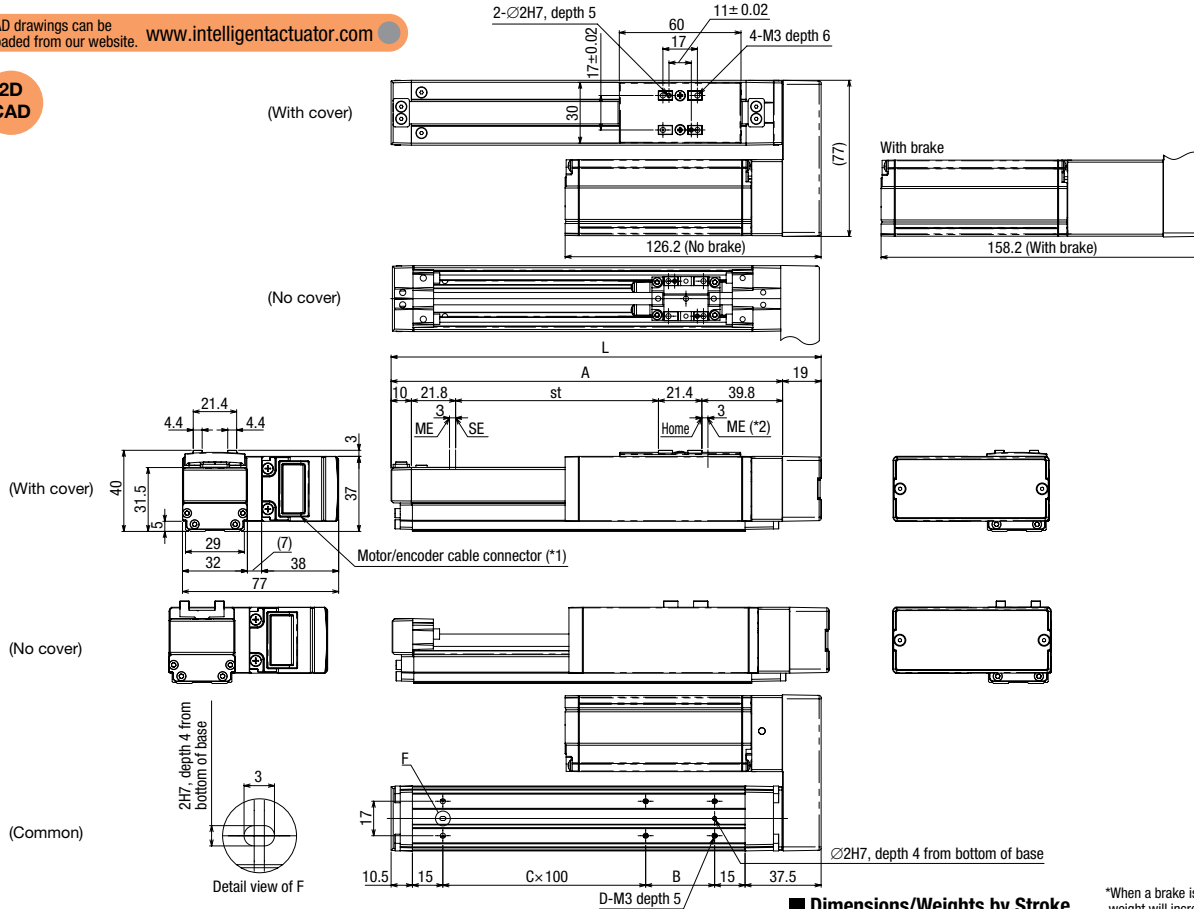

\*When a brake is equipped, the weight will increase by 0.2 kg

### Dimensions/Weights by Stroke

Stroke (mm)	50	100	150	200	250	300
L	162	212	262	312	362	412
A	143	193	243	293	343	393
B	84	34	84	34	84	34
C	0	1	1	2	2	3
D	4	6	6	8	8	10
Weight (kg)	With cover	0.8	0.8	0.9	1.0	1.1
	No cover	0.7	0.8	0.8	0.9	1.0

- (\*1) An integrated motor/encoder cable is provided. (Refer to P. 34.)  
 (\*2) The slider will move to the ME after home return, so pay attention to possible contact with surrounding structures/parts.  
 ME: Mechanical end  
 SE: Stroke end

## Controllers

### Applicable Controllers

RCP3-series actuators can be operated with any of the following controllers. Select a controller type appropriate for your specific application.

Name	Appearance	Model	Feature	Maximum number of positioning points	Power-supply voltage	Power-supply capacity	Standard price	Reference page
Positioner type		PCON-C-28PI-NP-2-0	Up to 512 positioning points are supported	512	DC24V	2 A max.	—	→P31
Positioner type conforming to safety category		PCON-CG-28PI-NP-2-0						
Solenoid valve type		PCON-CY-28PI-NP-2-0	Operable with the same control you use when operating a solenoid valve	3				
Pulse-train input type (differential line driver specification)		PCON-PL-28PI-NP-2-0	Pulse-train input type supporting differential line driver	(-)				
Pulse-train input type (open collector specification)		PCON-PO-28PI-NP-2-0	Pulse-train input type supporting open collector					
Serial communication type		PCON-SE-28PI-N-0-0	Dedicated serial communication type	64				
Field network type		RPCON-28P	Dedicated field network type	768				
Program control type		PSEL-C-1-28PI-NP-2-0	Up to 2 axes can be operated using programs	1500				

\*With PSEL controllers, the above information applies to the 1-axis specification.



## Dimensions

CAD drawings can be downloaded from our website. [www.intelligentactuator.com](http://www.intelligentactuator.com)

2D CAD

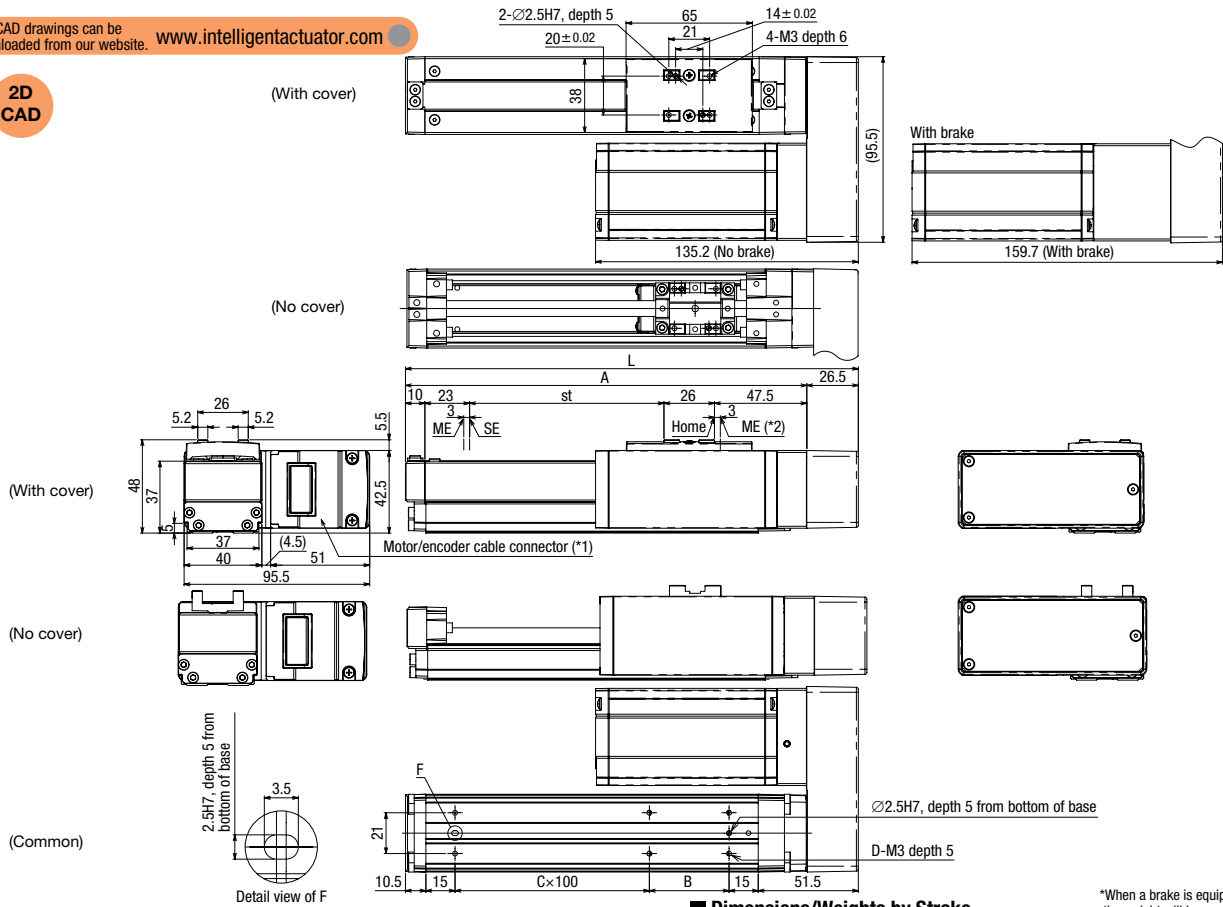

### Dimensions/Weights by Stroke

\*When a brake is equipped, the weight will increase by 0.3 kg

Stroke (mm)	50	100	150	200	250	300	350	400	
L	183	233	283	333	383	433	483	533	
A	156.5	206.5	256.5	306.5	356.5	406.5	456.5	506.5	
B	91	41	91	41	91	41	91	41	
C	0	1	1	2	2	3	3	4	
D	4	6	6	8	8	10	10	12	
Weight (kg)	With cover	1.1	1.2	1.3	1.4	1.5	1.6	1.7	1.8
	No cover	1.1	1.1	1.2	1.3	1.4	1.4	1.5	1.6

(\*1) An integrated motor/encoder cable is provided. (Refer to P. 34.)

(\*2) The slider will move to the ME after home return, so pay attention to possible contact with surrounding structures/parts.

ME: Mechanical end  
SE: Stroke end

## Controllers

### Applicable Controllers

RCP3-series actuators can be operated with any of the following controllers. Select a controller type appropriate for your specific application.

Name	Appearance	Model	Feature	Maximum number of positioning points	Power-supply voltage	Power-supply capacity	Standard price	Reference page
Positioner type		PCON-C-35PI-NP-2-0	Up to 512 positioning points are supported	512	DC24V	2 A max.	—	→P31
Positioner type conforming to safety category		PCON-CG-35PI-NP-2-0						
Solenoid valve type		PCON-CY-35PI-NP-2-0	Operable with the same control you use when operating a solenoid valve	3				
Pulse-train input type (differential line driver specification)		PCON-PL-35PI-NP-2-0	Pulse-train input type supporting differential line driver	(-)				
Pulse-train input type (open collector specification)		PCON-PO-35PI-NP-2-0	Pulse-train input type supporting open collector					
Serial communication type		PCON-SE-35PI-N-0-0	Dedicated serial communication type	64				
Field network type		RPCON-35P	Dedicated field network type	768				
Program control type		PSEL-C-1-35PI-NP-2-0	Up to 2 axes can be operated using programs	1500				

\*With PSEL controllers, the above information applies to the 1-axis specification.





## Dimensions

CAD drawings can be downloaded from our website. [www.intelligentactuator.com](http://www.intelligentactuator.com)

2D  
CAD

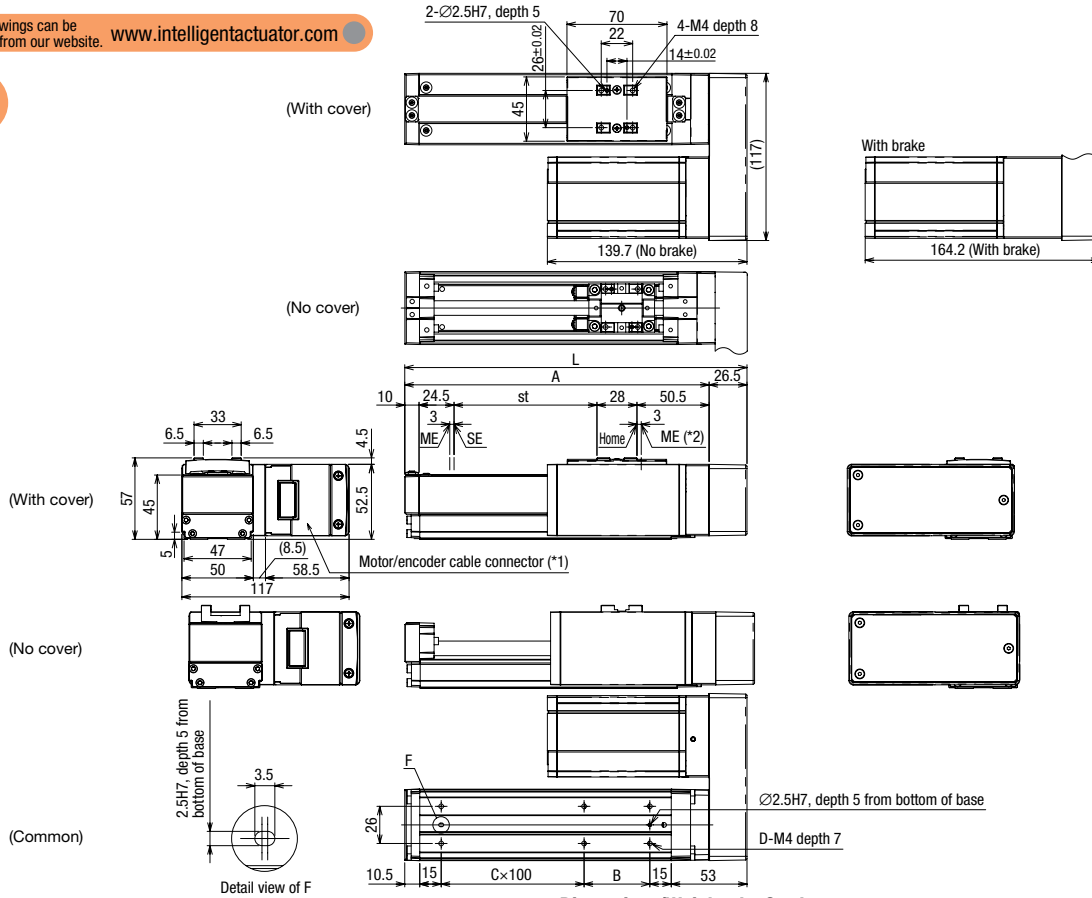

### ■ Dimensions/Weights by Stroke

\*When a brake is equipped, the weight will increase by 0.4 kg

Stroke (mm)	50	100	150	200	250	300	350	400	450	500
L	189.5	239.5	289.5	339.5	389.5	439.5	489.5	539.5	589.5	639.5
A	163	213	263	313	363	413	463	513	563	613
B	96	46	96	46	96	46	96	46	96	46
C	0	1	1	2	2	3	3	4	4	5
D	4	6	6	8	8	10	10	12	12	14
Weight (kg)	With cover	1.7	1.8	1.9	2.1	2.2	2.3	2.5	2.6	2.8
	No cover	1.6	1.7	1.8	1.9	2.0	2.1	2.3	2.4	2.5

(\*1) An integrated motor/encoder cable is provided. (Refer to P. 34.)

(\*2) The slider will move to the ME after home return, so pay attention to possible contact with surrounding structures/parts.

ME: Mechanical end  
SE: Stroke end

## Controllers

### Applicable Controllers

RCP3-series actuators can be operated with any of the following controllers. Select a controller type appropriate for your specific application.

Name	Appearance	Model	Feature	Maximum number of positioning points	Power-supply voltage	Power-supply capacity	Standard price	Reference page
Positioner type		PCON-C-42PI-NP-2-0	Up to 512 positioning points are supported	512	DC24V	2 A max.	—	→P31
Positioner type conforming to safety category		PCON-CG-42PI-NP-2-0						
Solenoid valve type		PCON-CY-42PI-NP-2-0	Operable with the same control you use when operating a solenoid valve	3				
Pulse-train input type (differential line driver specification)		PCON-PL-42PI-NP-2-0	Pulse-train input type supporting differential line driver	(-)				
Pulse-train input type (open collector specification)		PCON-PO-42PI-NP-2-0	Pulse-train input type supporting open collector					
Serial communication type		PCON-SE-42PI-N-0-0	Dedicated serial communication type	64				
Field network type		RPCON-42P	Dedicated field network type	768				
Program control type		PSEL-C-1-42PI-NP-2-0	Up to 2 axes can be operated using programs	1500				

\*With PSEL controllers, the above information applies to the 1-axis specification.



## Dimensions

CAD drawings can be downloaded from our website. [www.intelligentactuator.com](http://www.intelligentactuator.com)

2D  
CAD

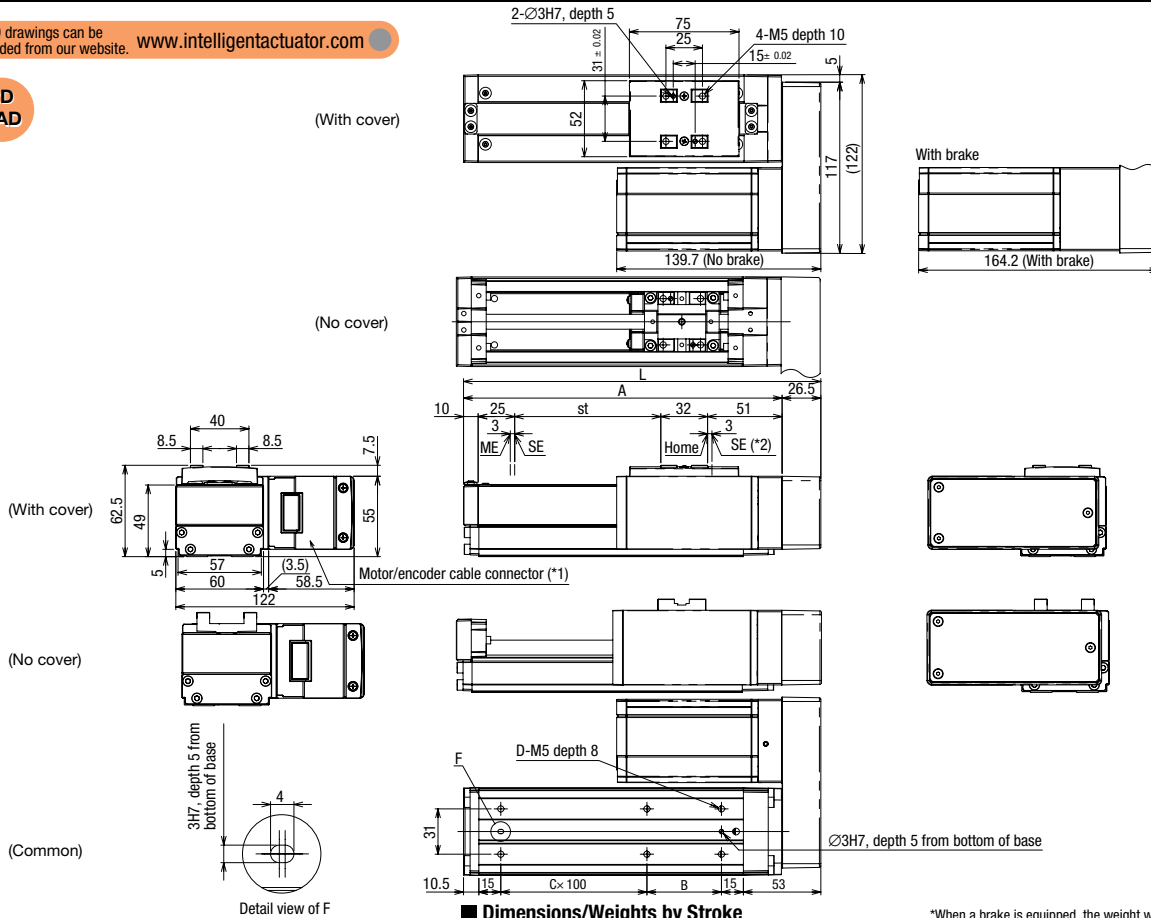

### Dimensions/Weights by Stroke

Stroke (mm)	50	100	150	200	250	300	350	400	450	500	550	600
L	194.5	244.5	294.5	344.5	394.5	444.5	494.5	544.5	594.5	644.5	694.5	744.5
A	168	218	268	318	368	418	468	518	568	618	668	718
B	101	51	101	51	101	51	101	51	101	51	101	51
C	0	1	1	2	2	3	3	4	4	5	5	6
D	4	6	6	8	8	10	10	12	12	14	14	16
Weight (kg)	With cover	1.9	2.1	2.3	2.4	2.6	2.8	3.0	3.1	3.3	3.5	3.6
	No cover	1.8	2.0	2.1	2.3	2.4	2.6	2.7	2.9	3.0	3.1	3.3

(\*1) An integrated motor/encoder cable is provided. (Refer to P. 34.)

(\*2) The slider will move to the ME after home return, so pay attention to possible contact with surrounding structures/parts.

ME: Mechanical end  
SE: Stroke end

## Controllers

### Applicable Controllers

RCP3-series actuators can be operated with any of the following controllers. Select a controller type appropriate for your specific application.

Name	Appearance	Model	Feature	Maximum number of positioning points	Power-supply voltage	Power-supply capacity	Standard price	Reference page
Positioner type		PCON-C-42PI-NP-2-0	Up to 512 positioning points are supported	512	DC24V	2 A max.	—	→P31
Positioner type conforming to safety category		PCON-CG-42PI-NP-2-0						
Solenoid valve type		PCON-CY-42PI-NP-2-0	Operable with the same control you use when operating a solenoid valve	3				
Pulse-train input type (differential line driver specification)		PCON-PL-42PI-NP-2-0	Pulse-train input type supporting differential line driver	(-)				
Pulse-train input type (open collector specification)		PCON-PO-42PI-NP-2-0	Pulse-train input type supporting open collector					
Serial communication type		PCON-SE-42PI-N-0-0	Dedicated serial communication type	64				
Field network type		RPCON-42P	Dedicated field network type	768				
Program control type		PSEL-C-1-42PI-NP-2-0	Up to 2 axes can be operated using programs	1500				

\*With PSEL controllers, the above information applies to the 1-axis specification.





## Dimensions

CAD drawings can be downloaded from our website. [www.intelligentactuator.com](http://www.intelligentactuator.com)

2D CAD

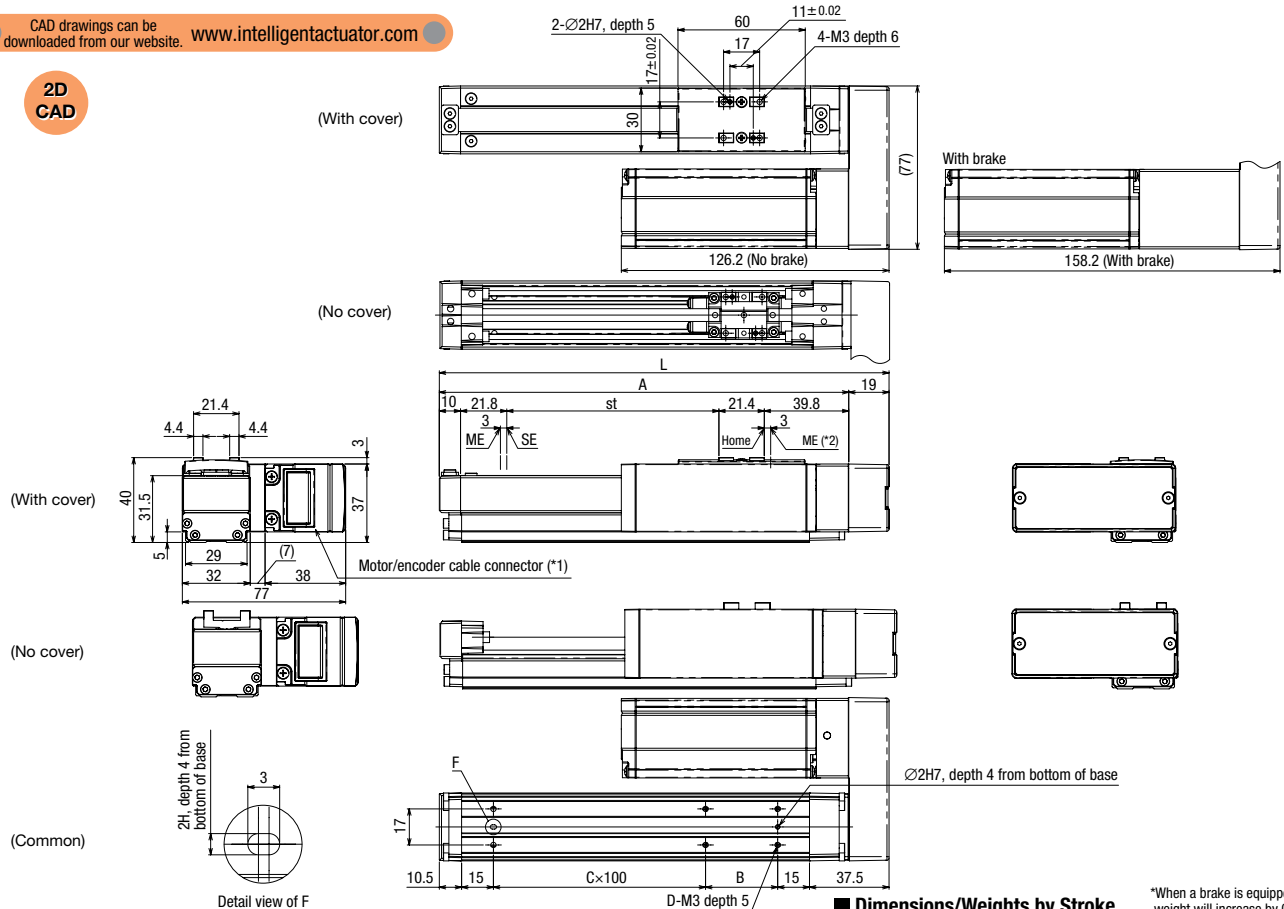

\*When a brake is equipped, the weight will increase by 0.2 kg

### Dimensions/Weights by Stroke

Stroke (mm)	50	100	150	200	250	300
L	162	212	262	312	362	412
A	143	193	243	293	343	393
B	84	34	84	34	84	34
C	0	1	1	2	2	3
D	4	6	6	8	8	10
Weight (kg)	With cover	0.7	0.7	0.8	0.9	1.0
	No cover	0.6	0.7	0.7	0.8	0.9

(\*1) An integrated motor/encoder cable is provided. (Refer to P. 34.)

(\*2) The slider will move to the ME after home return, so pay attention to possible contact with surrounding structures/parts.

ME: Mechanical end  
SE: Stroke end

## Controllers

### Applicable Controllers

RCA2-series actuators can be operated with any of the following controllers. Select a controller type appropriate for your specific application.

Name	Appearance	Model	Feature	Maximum number of positioning points	Power-supply voltage	Power-supply capacity	Standard price	Reference page
Positioner type		ACON-C-10I-NP-2-0	Up to 512 positioning points are supported	512	DC24V	5.1 A max. (The specific capacity varies depending on the actuator.)	—	→P31
Positioner type conforming to safety category		ACON-CG-10I-NP-2-0						
Solenoid valve type		ACON-CY-10I-NP-2-0	Operable with the same control you use when operating a solenoid valve	3				
Pulse-train input type (differential line driver specification)		ACON-PL-10I-NP-2-0	Pulse-train input type supporting differential line driver	(-)				
Pulse-train input type (open collector specification)		ACON-PO-10I-NP-2-0	Pulse-train input type supporting open collector					
Serial communication type		ACON-SE-10I-N-0-0	Dedicated serial communication type	64				
Field network type		RACON-10	Dedicated field network type	768				
Program control type		ASEL-C-1-10I-NP-2-0	Up to 2 axes can be operated using programs	1500				

\*With ASEL controllers, the above information applies to the 1-axis specification.

# RCA2-SA4R

ROBO Cylinder, Slider Type, Actuator Width 40 mm, Servo Motor, Motor-reversing Specification

Model Name Specifications	<b>RCA2-SA4R</b>	<b>I</b>	<b>20</b>			<b>A1</b>			
	Series	Type	Encoder type	Motor type	Lead	Stroke	Applicable controllers	Cable length	Options
	I: Incremental specification	20: Servo motor 20 W	10: 10 mm 5: 5 mm 2.5: 2.5 mm	50:50 mm 400:400 mm (Set in 50-mm pitch)	A1: ACON ASEL	N: None P: 1 m S: 3 m M: 5 m X□□: Specified length	B: With brake LA: Power-saving feature ML: Motor reversed to left (standard) MR: Motor reversed to right NCO: No cover NM: Counter-home specification		

\*Refer to P. 34 for the cables sold separately for maintenance purposes.

Power-saving feature

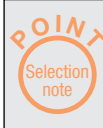
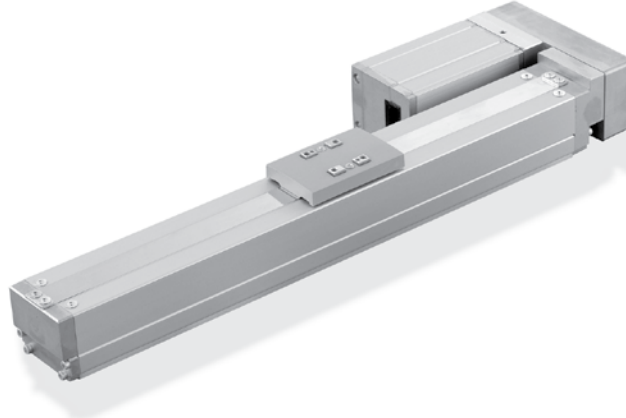

(1) The load capacities are based on operation at an acceleration of 0.3 G (or 0.2 G when the lead is 2.5 or the actuator is used vertically). The acceleration cannot be increased beyond this level.

### Actuator Specifications

#### Strokes and Maximum Speeds

Model	Motor output (W)	Lead (mm)	Maximum load capacity		Maximum push force (N)	Stroke (mm)
			Horizontal (kg)	Vertical (kg)		
RCA2-SA4R-I-20-10-①-A1-②-③	20	10	2	1	34	50 ~ 400 (Set in 50-mm pitch)
RCA2-SA4R-I-20-5-①-A1-②-③		5	4	1.5	68	
RCA2-SA4R-I-20-2.5-①-A1-②-③		2.5	6	3	136	

#### Strokes and Maximum Speeds

Stroke (mm)	50 ~ 400 (Set in 50-mm pitch)	
	Lead (mm)	Stroke (mm)
10	10	500
5	5	250
2.5	2.5	125

Explanation of codes: ① Stroke ② Cable length ③ Options

(Unit: mm/sec)

#### ① Price List by Stroke (Standard Prices)

① Stroke (mm)	Type code	
	SA4R	
	Encoder type	
	Incremental	
	Actuator cover	
	With cover (Standard)	No cover (optional)
50	—	—
100	—	—
150	—	—
200	—	—
250	—	—
300	—	—
350	—	—
400	—	—

#### ② Price List by Cable Length (Standard Prices)

Type	Model	Standard price
Standard type (robot cable)	P (1m)	—
	S (3m)	—
	M (5m)	—
Special length	X06 (6m) ~ X10 (10m)	—
	X11 (11m) ~ X15 (15m)	—
	X16 (16m) ~ X20 (20m)	—
		—

\*Refer to P. 34 for the cables sold separately for maintenance purposes.

#### ③ Price List of Options (Standard Prices)

Name	Option code	Reference page	Standard price
With brake	B	—	—
Power-saving feature	LA	—	Free of charge
Motor reversed to left (standard)	ML	—	Free of charge
Motor reversed to right	MR	—	Free of charge
No cover	NCO	—	See above.
Counter-home specification	NM	—	Free of charge

#### Actuator Specifications

Item	Description
Drive method	Ball screw, $\phi 8$ mm, rolled C10
Positioning repeatability	$\pm 0.05$ mm
Lost motion	0.1 mm or less
Base	Material: Aluminum with dedicated alumite treatment
Dynamic allowable load moment (*1)	Ma: 3.04N·m Mb: 4.31N·m Mc: 5.00N·m
Overhang load length	120 mm or less
Surrounding air temperature/humidity	0 to 40°C, 85%RH or below (non-condensing)
Traveling life	5000km

(\*1) Refer to the RCP3/RCA2 Coupling Specification catalog for the moment load calculation.

Directions of allowable load moments



## Dimensions

CAD drawings can be downloaded from our website. [www.intelligentactuator.com](http://www.intelligentactuator.com)

2D CAD

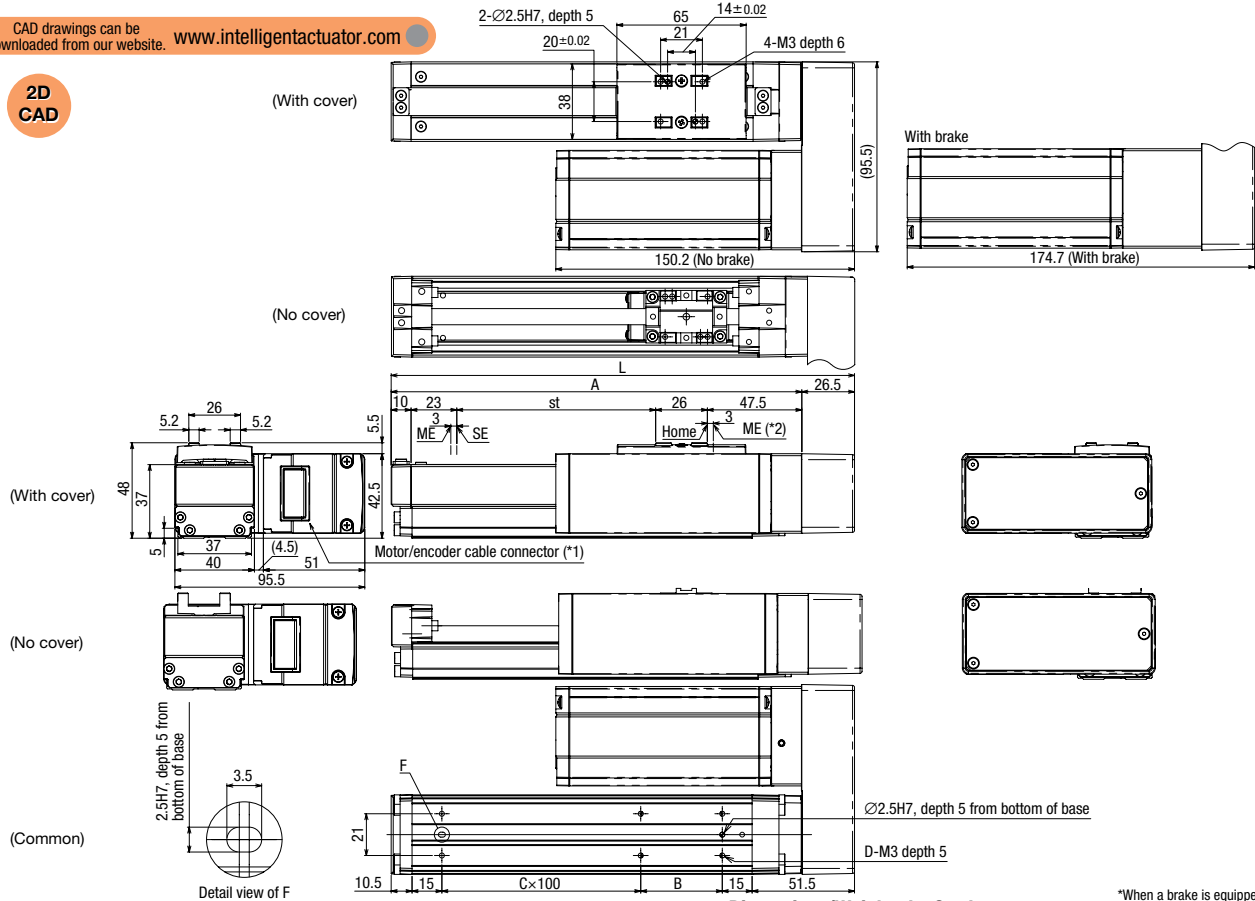

### Dimensions/Weights by Stroke

\*When a brake is equipped, the weight will increase by 0.3 kg

Stroke (mm)	50	100	150	200	250	300	350	400	
L	183	233	283	333	383	433	483	533	
A	156.5	206.5	256.5	306.5	356.5	406.5	456.5	506.5	
B	91	41	91	41	91	41	91	41	
C	0	1	1	2	2	3	3	4	
D	4	6	6	8	8	10	10	12	
Weight (kg)	With cover	1.1	1.2	1.3	1.3	1.4	1.5	1.6	1.7
	No cover	1.0	1.1	1.2	1.2	1.3	1.4	1.5	1.5

- (\*1) An integrated motor/encoder cable is provided. (Refer to P. 34.)  
 (\*2) The slider will move to the ME after home return, so pay attention to possible contact with surrounding structures/parts.  
 ME: Mechanical end  
 SE: Stroke end

## Controllers

### Applicable Controllers

RCA2-series actuators can be operated with any of the following controllers. Select a controller type appropriate for your specific application.

Name	Appearance	Model	Feature	Maximum number of positioning points	Power-supply voltage	Power-supply capacity	Standard price	Reference page
Positioner type		ACON-C-20SI-NP-2-0	Up to 512 positioning points are supported	512	DC24V	5.1 A max. (The specific capacity varies depending on the actuator.)	—	→P31
Positioner type conforming to safety category		ACON-CG-20SI-NP-2-0						
Solenoid valve type		ACON-CY-20SI-NP-2-0	Operable with the same control you use when operating a solenoid valve	3				
Pulse-train input type (differential line driver specification)		ACON-PL-20SI-NP-2-0	Pulse-train input type supporting differential line driver	(-)				
Pulse-train input type (open collector specification)		ACON-PO-20SI-NP-2-0	Pulse-train input type supporting open collector					
Serial communication type		ACON-SE-20SI-N-0-0	Dedicated serial communication type	64				
Field network type		RACON-20S	Dedicated field network type	768				
Program control type		ASEL-C-1-20SI-NP-2-0	Up to 2 axes can be operated using programs	1500				

\*With ASEL controllers, the above information applies to the 1-axis specification.

# RCA2-SA5R

ROBO Cylinder, Slider Type, Actuator Width 50 mm, Servo Motor, Motor-reversing Specification

Model Name Specifications: **RCA2** - **SA5R** - **I** - **20** -  -  - **A1** -  -

Series - Type - Encoder type - Motor type - Lead - Stroke - Applicable controllers - Cable length - Options

I: Incremental specification    20: Servo motor 20 W    12: 12 mm    50: 50 mm    A1: ACON    N: None    B: With brake  
 6: 6 mm    3: 3 mm    ASEL    P: 1 m    LA: Power-saving feature  
 500: 500 mm (Set in 50-mm pitch)    M: 5 m    ML: Motor reversed to left (standard)  
 MR: Motor reversed to right  
 NCO: No cover  
 NM: Counter-home specification

\*Refer to P. 34 for the cables sold separately for maintenance purposes.

Power-saving feature

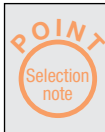
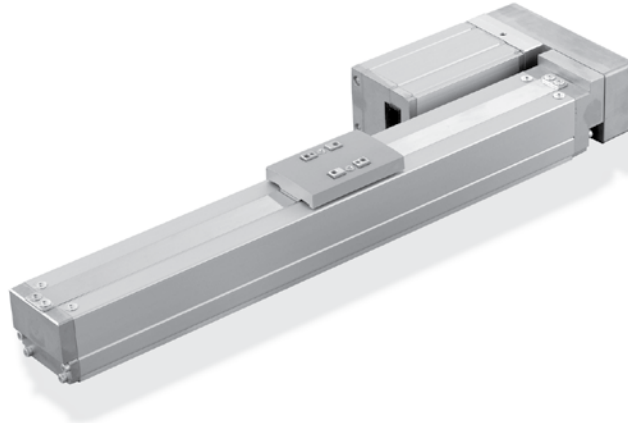

(1) The load capacities are based on operation at an acceleration of 0.3 G (or 0.2 G when the lead is 3 or the actuator is used vertically). The acceleration cannot be increased beyond this level.

**Actuator Specifications**

**Strokes and Maximum Speeds**

Model	Motor output (W)	Lead (mm)	Maximum load capacity		Maximum push force (N)	Stroke (mm)
			Horizontal (kg)	Vertical (kg)		
RCA2-SA5R-I-20-12-①-A1-②-③	20	12	3	1	17	50 ~ 500 (Set in 50-mm pitch)
RCA2-SA5R-I-20-6-①-A1-②-③		6	6	1.5	34	
RCA2-SA5R-I-20-3-①-A1-②-③		3	9	3	68	

**Strokes and Maximum Speeds**

Stroke (mm) Lead (mm)	50 ~ 500 (Set in 50-mm pitch)	
	12	600
6	300	
3	150	

Explanation of codes: ① Stroke ② Cable length ③ Options

(Unit: mm/sec)

**① Price List by Stroke (Standard Prices)**

① Stroke (mm)	Type code	
	SA5R	
	Encoder type	
	Incremental	
	Actuator cover	
	With cover (Standard)	No cover (optional)
50	—	—
100	—	—
150	—	—
200	—	—
250	—	—
300	—	—
350	—	—
400	—	—
450	—	—
500	—	—

**② Price List by Cable Length (Standard Prices)**

Type	Model	Standard price
Standard type (robot cable)	P (1m)	—
	S (3m)	—
	M (5m)	—
Special length	X06 (6m) ~ X10 (10m)	—
	X11 (11m) ~ X15 (15m)	—
	X16 (16m) ~ X20 (20m)	—

\*Refer to P. 34 for the cables sold separately for maintenance purposes.

**③ Price List of Options (Standard Prices)**

Name	Option code	Reference page	Standard price
With brake	B	—	—
Power-saving feature	LA	—	Free of charge
Motor reversed to left (standard)	ML	—	Free of charge
Motor reversed to right	MR	—	Free of charge
No cover	NCO	—	See above.
Counter-home specification	NM	—	Free of charge

**Actuator Specifications**

Item	Description
Drive method	Ball screw, φ10 mm, rolled C10
Positioning repeatability	±0.05mm
Lost motion	0.1 mm or less
Base	Material: Aluminum with dedicated alumite treatment
Dynamic allowable load moment (*1)	Ma: 3.92N·m Mb: 5.58N·m Mc: 8.53N·m
Overhang load length	130 mm or less
Surrounding air temperature/humidity	0 to 40°C, 85%RH or below (non-condensing)
Traveling life	5000km

(\*1) Refer to the RCP3/RCA2 Coupling Specification catalog for the moment load calculation.

Directions of allowable load moments

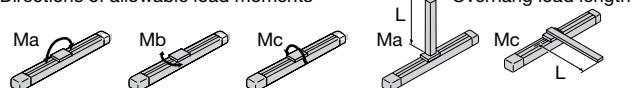



## Dimensions

CAD drawings can be downloaded from our website. [www.intelligentactuator.com](http://www.intelligentactuator.com)

2D  
CAD

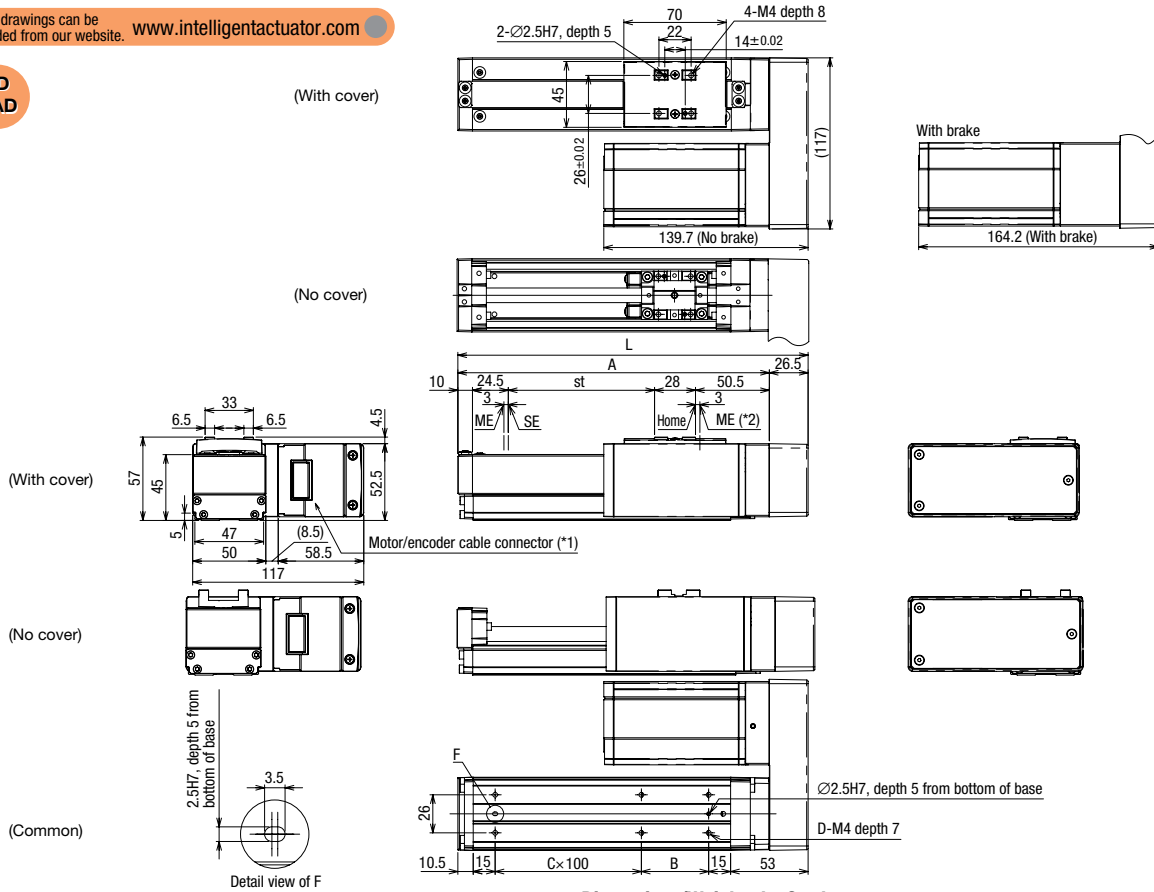

### Dimensions/Weights by Stroke

\*When a brake is equipped, the weight will increase by 0.4 kg

Stroke (mm)	50	100	150	200	250	300	350	400	450	500
L	189.5	239.5	289.5	339.5	389.5	439.5	489.5	539.5	589.5	639.5
A	163	213	263	313	363	413	463	513	563	613
B	96	46	96	46	96	46	96	46	96	46
C	0	1	1	2	2	3	3	4	4	5
D	4	6	6	8	8	10	10	12	12	14
Weight (kg)	With cover	1.5	1.7	1.8	1.9	2.1	2.2	2.3	2.5	2.6
	No cover	1.4	1.6	1.7	1.8	1.9	2.0	2.1	2.2	2.3

(\*1) An integrated motor/encoder cable is provided. (Refer to P. 34.)  
 (\*2) The slider will move to the ME after home return, so pay attention to possible contact with surrounding structures/parts.

ME: Mechanical end  
SE: Stroke end

## Controllers

### Applicable Controllers

RCA2-series actuators can be operated with any of the following controllers. Select a controller type appropriate for your specific application.

Name	Appearance	Model	Feature	Maximum number of positioning points	Power-supply voltage	Power-supply capacity	Standard price	Reference page
Positioner type		ACON-C-20I-NP-2-0	Up to 512 positioning points are supported	512	DC24V	5.1 A max. (The specific capacity varies depending on the actuator.)	—	→P31
Positioner type conforming to safety category		ACON-CG-20I-NP-2-0						
Solenoid valve type		ACON-CY-20I-NP-2-0	Operable with the same control you use when operating a solenoid valve	3				
Pulse-train input type (differential line driver specification)		ACON-PL-20I-NP-2-0	Pulse-train input type supporting differential line driver	(-)				
Pulse-train input type (open collector specification)		ACON-PO-20I-NP-2-0	Pulse-train input type supporting open collector					
Serial communication type		ACON-SE-20I-N-0-0	Dedicated serial communication type	64				
Field network type		RACON-20	Dedicated field network type	768				
Program control type		ASEL-C-1-20I-NP-2-0	Up to 2 axes can be operated using programs	1500				

\*With ASEL controllers, the above information applies to the 1-axis specification.



## Dimensions

CAD drawings can be downloaded from our website. [www.intelligentactuator.com](http://www.intelligentactuator.com)

2D  
CAD

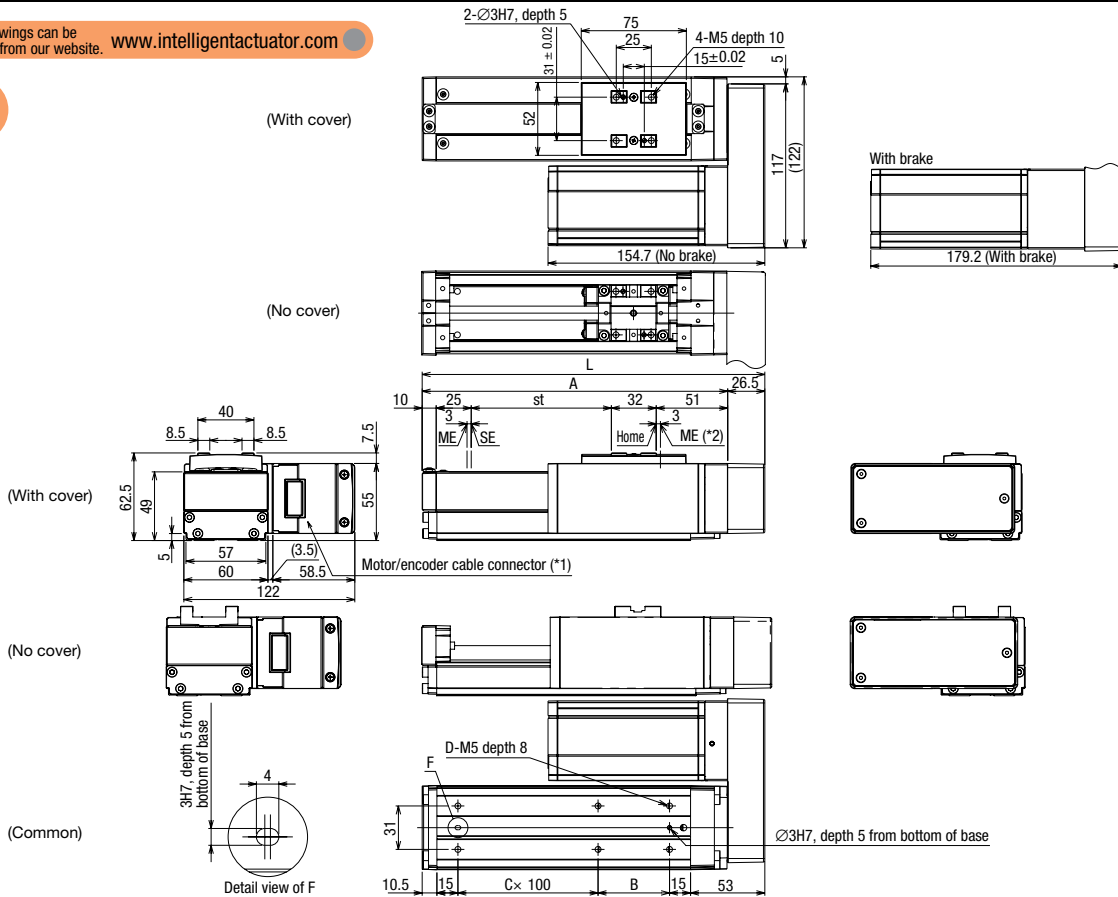

### Dimensions/Weights by Stroke

\*When a brake is equipped, the weight will increase by 0.4 kg

Stroke (mm)	50	100	150	200	250	300	350	400	450	500	550	600	
L	194.5	244.5	294.5	344.5	394.5	444.5	494.5	544.5	594.5	644.5	694.5	744.5	
A	168	218	268	318	368	418	468	518	568	618	668	718	
B	101	51	101	51	101	51	101	51	101	51	101	51	
C	0	1	1	2	2	3	3	4	4	5	5	6	
D	4	6	6	8	8	10	10	12	12	14	14	16	
Weight (kg)	With cover	1.9	2.0	2.2	2.4	2.6	2.7	2.9	3.1	3.2	3.4	3.6	3.8
	No cover	1.8	1.9	2.1	2.2	2.4	2.5	2.6	2.8	2.9	3.1	3.2	3.4

(\*1) An integrated motor/encoder cable is provided. (Refer to P. 34.)

(\*2) The slider will move to the ME after home return, so pay attention to possible contact with surrounding structures/parts.

ME: Mechanical end  
SE: Stroke end

## Controllers

### Applicable Controllers

RCA2-series actuators can be operated with any of the following controllers. Select a controller type appropriate for your specific application.

Name	Appearance	Model	Feature	Maximum number of positioning points	Power-supply voltage	Power-supply capacity	Standard price	Reference page
Positioner type		ACON-C-30I-NP-2-0	Up to 512 positioning points are supported	512	DC24V	5.1 A max. (The specific capacity varies depending on the actuator.)	—	→P31
Positioner type conforming to safety category		ACON-CG-30I-NP-2-0						
Solenoid valve type		ACON-CY-30I-NP-2-0	Operable with the same control you use when operating a solenoid valve	3				
Pulse-train input type (differential line driver specification)		ACON-PL-30I-NP-2-0	Pulse-train input type supporting differential line driver	(-)				
Pulse-train input type (open collector specification)		ACON-PO-30I-NP-2-0	Pulse-train input type supporting open collector					
Serial communication type		ACON-SE-30I-N-0-0	Dedicated serial communication type	64				
Field network type		RACON-30	Dedicated field network type	768				
Program control type		ASEL-C-1-30I-NP-2-0	Up to 2 axes can be operated using programs	1500				

\*With ASEL controllers, the above information applies to the 1-axis specification.





## Dimensions

CAD drawings can be downloaded from our website. [www.intelligentactuator.com](http://www.intelligentactuator.com)

2D  
CAD

\* Take note that with a 25-stroke model with brake, the motor unit extends from the end face of the table.

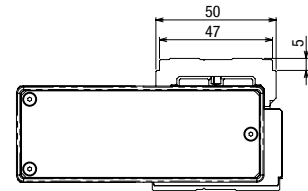
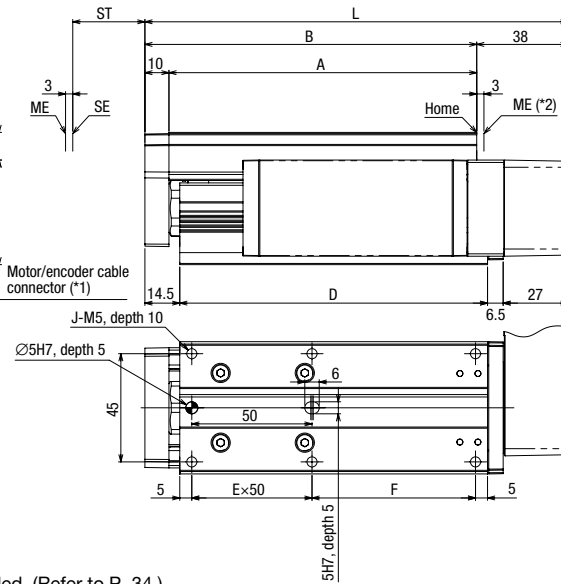
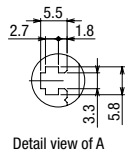
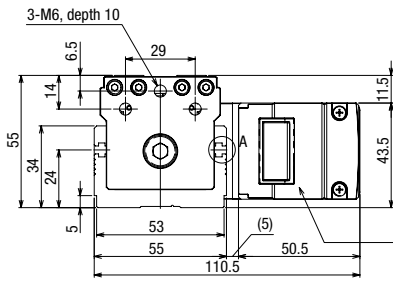
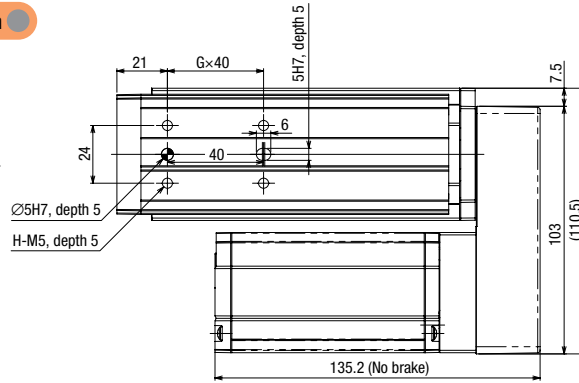
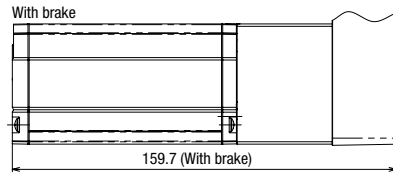

### Dimensions/Weights by Stroke

\*When a brake is equipped, the weight will increase by 0.3 kg

Stroke (mm)	25	50	75	100
L	151	176	201	226
A	103	128	153	178
B	113	138	163	188
D	103	128	153	178
E	1	1	2	2
F	43	68	43	68
G	1	1	2	2
H	4	4	6	6
J	6	6	8	8
Weight (kg)	1.4	1.6	1.7	1.9

(\*1) An integrated motor/encoder cable is provided. (Refer to P. 34.)  
 (\*2) The slider will move to the ME after home return, so pay attention to possible contact with surrounding structures/parts.  
 ME: Mechanical end  
 SE: Stroke end

## Controllers

### Applicable Controllers

RCP3-series actuators can be operated with any of the following controllers. Select a controller type appropriate for your specific application.

Name	Appearance	Model	Feature	Maximum number of positioning points	Power-supply voltage	Power-supply capacity	Standard price	Reference page
Positioner type		PCON-C-35PI-NP-2-0	Up to 512 positioning points are supported	512	DC24V	2 A max.	—	→P31
Positioner type conforming to safety category		PCON-CG-35PI-NP-2-0						
Solenoid valve type		PCON-CY-35PI-NP-2-0	Operable with the same control you use when operating a solenoid valve	3				
Pulse-train input type (differential line driver specification)		PCON-PL-35PI-NP-2-0	Pulse-train input type supporting differential line driver	(-)				
Pulse-train input type (open collector specification)		PCON-PO-35PI-NP-2-0	Pulse-train input type supporting open collector					
Serial communication type		PCON-SE-35PI-N-0-0	Dedicated serial communication type	64				
Field network type		RPCON-35P	Dedicated field network type	768				
Program control type		PSEL-C-1-35PI-NP-2-0	Up to 2 axes can be operated using programs	1500				

\*With PSEL controllers, the above information applies to the 1-axis specification.



## Dimensions

CAD drawings can be downloaded from our website. [www.intelligentactuator.com](http://www.intelligentactuator.com)

2D CAD

\* Take note that with a 25-stroke model with brake, the motor unit extends from the end face of the table.

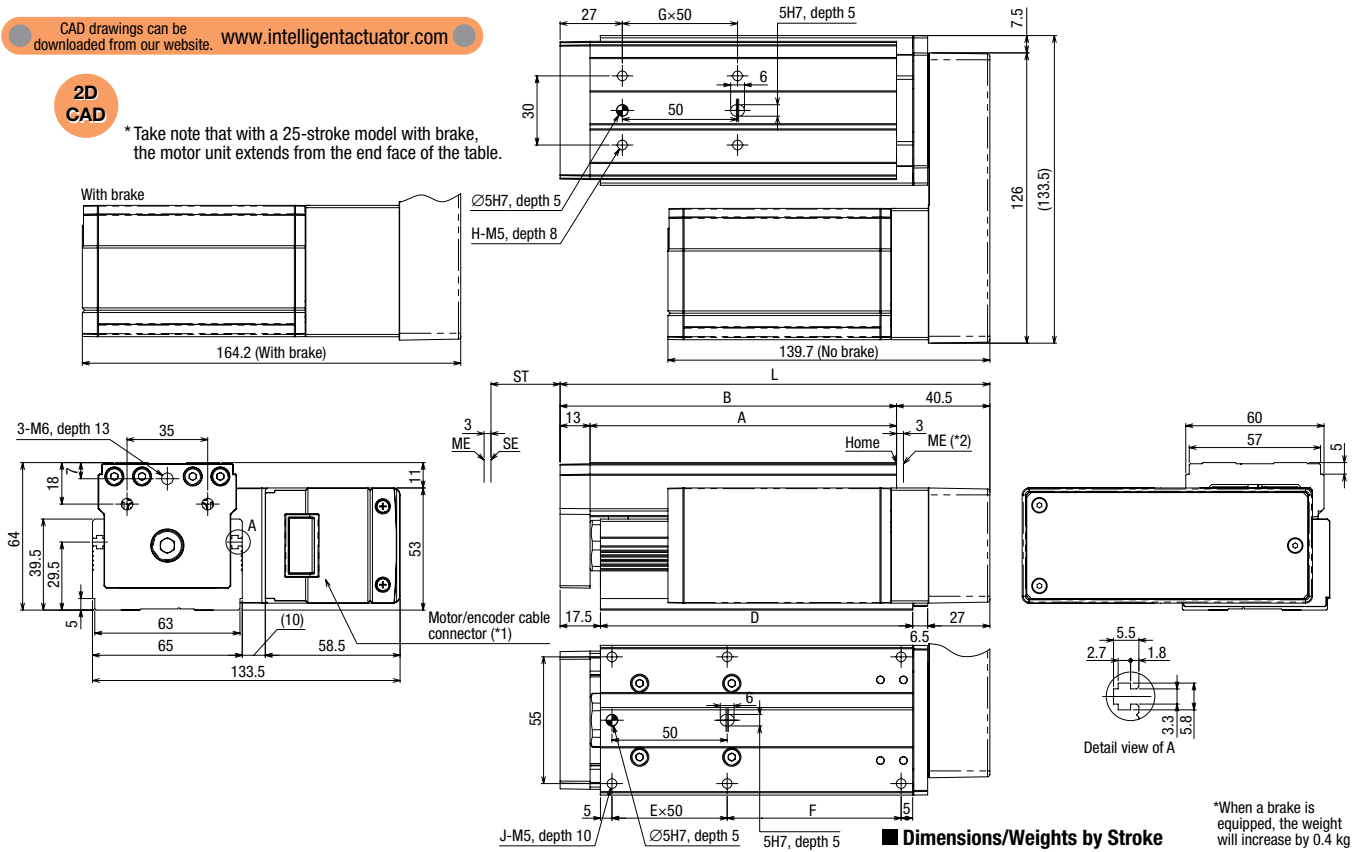

\*When a brake is equipped, the weight will increase by 0.4 kg

### Dimensions/Weights by Stroke

Stroke (mm)	25	50	75	100	125	150
L	161.5	186.5	211.5	236.5	261.5	286.5
A	108	133	158	183	208	233
B	121	146	171	196	221	246
D	110.5	135.5	160.5	185.5	210.5	235.5
E	1	1	2	2	3	3
F	50.5	75.5	50.5	75.5	50.5	75.5
G	1	1	2	2	3	3
H	4	4	6	6	8	8
J	6	6	8	8	10	10
Weight (kg)	2.1	2.3	2.5	2.7	2.9	3.1

(\*1) An integrated motor/encoder cable is provided. (Refer to P. 34.)  
 (\*2) The slider will move to the ME after home return, so pay attention to possible contact with surrounding structures/parts.  
 ME: Mechanical end  
 SE: Stroke end

## Controllers

### Applicable Controllers

RCP3-series actuators can be operated with any of the following controllers. Select a controller type appropriate for your specific application.

Name	Appearance	Model	Feature	Maximum number of positioning points	Power-supply voltage	Power-supply capacity	Standard price	Reference page
Positioner type		PCON-C-42PI-NP-2-0	Up to 512 positioning points are supported	512	DC24V	2 A max.	—	→P31
Positioner type conforming to safety category		PCON-CG-42PI-NP-2-0						
Solenoid valve type		PCON-CY-42PI-NP-2-0	Operable with the same control you use when operating a solenoid valve	3				
Pulse-train input type (differential line driver specification)		PCON-PL-42PI-NP-2-0	Pulse-train input type supporting differential line driver	(-)				
Pulse-train input type (open collector specification)		PCON-PO-42PI-NP-2-0	Pulse-train input type supporting open collector					
Serial communication type		PCON-SE-42PI-N-0-0	Dedicated serial communication type	64				
Field network type		RPCON-42P	Dedicated field network type	768				
Program control type		PSEL-C-1-42PI-NP-2-0	Up to 2 axes can be operated using programs	1500				

\*With PSEL controllers, the above information applies to the 1-axis specification.

# RCP3-TA7R

ROBO Cylinder, Table Type, Actuator Width 75 mm, Pulse Motor, Motor-reversing Specification

**Model Name Specifications** **RCP3** - **TA7R** - **I** - **42P** -  -  - **P1** -  -

Series - Type - Encoder type - Motor type - Lead - Stroke - Applicable controllers - Cable length - Options

I: Incremental specification    42P: Pulse motor □ 42 size    12: 12 mm 6: 6 mm 3: 3 mm    25: 25 mm 200: 200 mm (Set in 25-mm pitch)    P1: PCON PSEL    N: None P: 1 m S: 3 m M: 5 m    B: With brake ML: Motor reversed to left (standard) MR: Motor reversed to right NM: Counter-home specification

\*For details on the items comprising the model name, refer to P. 2.    X□□: Specified length

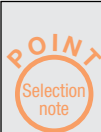
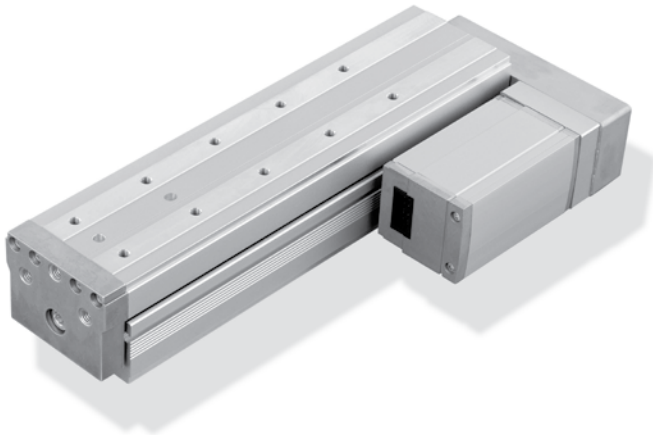

- Since the RCP3 series uses a pulse motor, its load capacity drops as the speed increases. Use the correlation diagrams of speed and load capacity provided on the right to check the load capacity achieved at the desired speed.
- Take note that the maximum speed varies depending on whether the actuator is used horizontally or vertically.
- The load capacities are based on operation at an acceleration of 0.3 G (or 0.2 G when the lead is 3 or the actuator is used vertically). The acceleration cannot be increased beyond this level.

**Correlation Diagrams of Speed and Load Capacity**  
 Due to the characteristics of the pulse motor installed inside, the RCP3 series allows the load capacity to drop as the speed increases. Use the graphs below to check if the desired speed and load capacity can be satisfied.

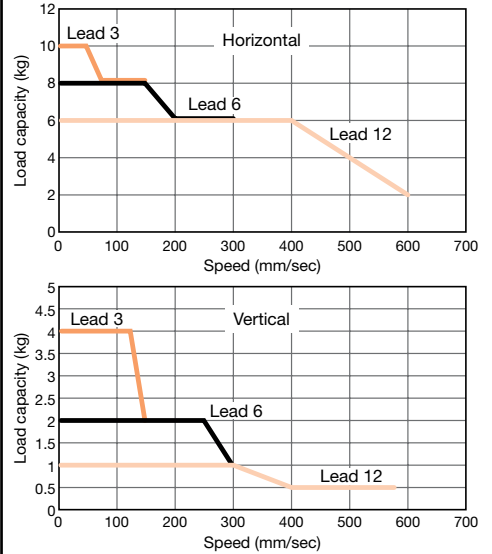

### Actuator Specifications

#### Strokes and Maximum Speeds

Model	Lead (mm)	Maximum load capacity		Maximum push force (N)	Stroke (mm)
		Horizontal (kg)	Vertical (kg)		
RCP3-TA7R-I-42P-12-①-P1-②-③	12	~6	~1	47	25 ~ 200 (Set in 25-mm pitch)
RCP3-TA7R-I-42P-6-①-P1-②-③	6	~8	~2	95	
RCP3-TA7R-I-42P-3-①-P1-②-③	3	~10	~4	189	

Explanation of codes: ① Stroke ② Cable length ③ Options

#### Strokes and Maximum Speeds

Stroke (mm) Lead (mm)	25 ~ 200 (Set in 25-mm pitch)	
	12	600 <580>
6	300	
3	150	

\*The value in <> applies when the actuator is used vertically. (Unit: mm/sec)

#### ① Price List by Stroke (Standard Prices)

① Stroke (mm)	Type code
	Encoder type
25	TA7R Incremental
50	—
75	—
100	—
125	—
150	—
175	—
200	—

#### ② Price List by Cable Length (Standard Prices)

Type	Model	Standard price
Standard type (robot cable)	P (1m)	—
	S (3m)	—
	M (5m)	—
Special length	X06 (6m) ~ X10 (10m)	—
	X11 (11m) ~ X15 (15m)	—
	X16 (16m) ~ X20 (20m)	—
	—	—

\*Refer to P. 34 for the cables sold separately for maintenance purposes.

#### ③ Price List of Options (Standard Prices)

Name	Option code	Reference page	Standard price
With brake	B	—	—
Motor reversed to left (standard)	ML	—	Free of charge
Motor reversed to right	MR	—	Free of charge
Counter-home specification	NM	—	Free of charge

#### Actuator Specifications

Item	Description
Drive method	Ball screw, φ10 mm, rolled C10
Positioning repeatability	±0.05mm
Lost motion	0.1 mm or less
Base	Material: Aluminum with dedicated alumite treatment
Dynamic allowable load moment (*1)	Ma: 9.91N·m Mb: 14.13N·m Mc: 28.65N·m
Overhang load length	Within the range of the applicable load moment
Surrounding air temperature/humidity	0 to 40°C, 85%RH or below (non-condensing)
Traveling life	5000km

(\*1) Refer to the RCP3/RCA2 Coupling Specification catalog for the moment load calculation.

Directions of allowable load moments



## Dimensions

CAD drawings can be downloaded from our website. [www.intelligentactuator.com](http://www.intelligentactuator.com)

2D CAD

\*Take note that with a 25-stroke model with brake, the motor unit extends from the end face of the table.

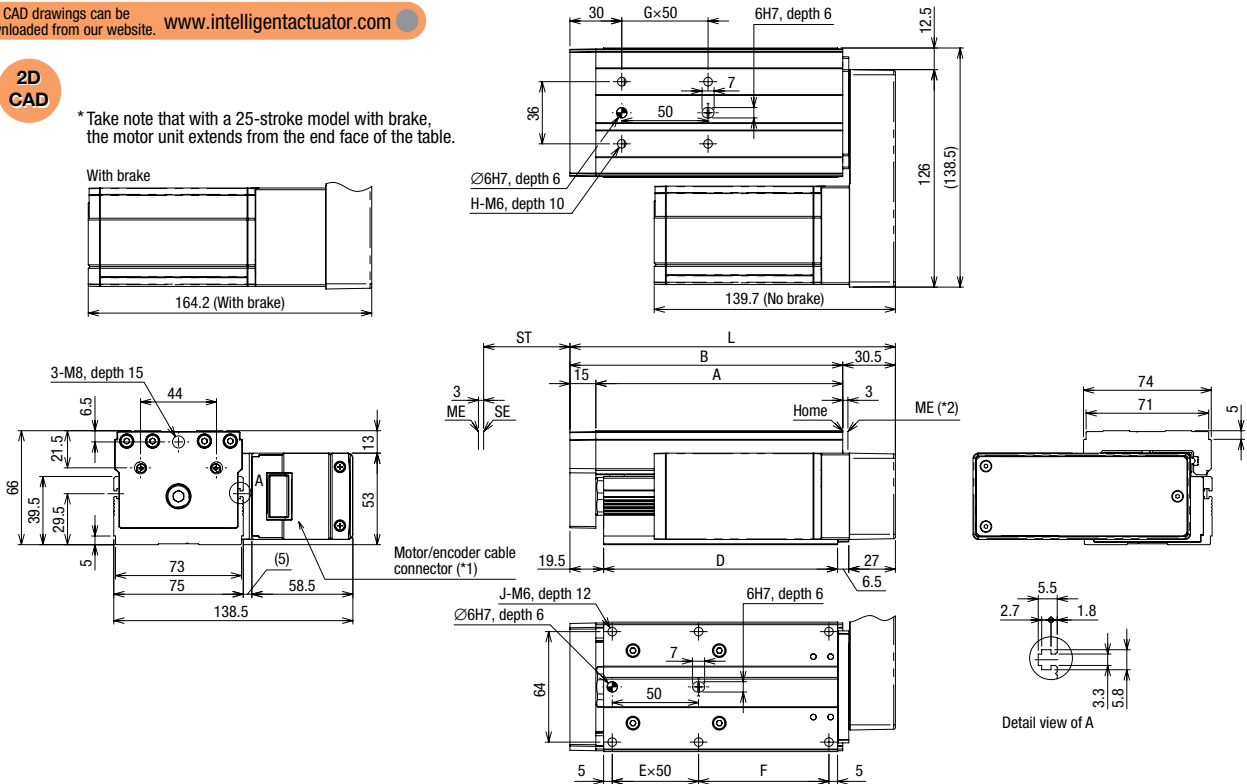

### ■ Dimensions/Weights by Stroke

\*When a brake is equipped, the weight will increase by 0.4 kg

Stroke (mm)	25	50	75	100	125	150	175	200
L	163.5	188.5	213.5	238.5	263.5	288.5	313.5	338.5
A	118	143	168	193	218	243	268	293
B	133	158	183	208	233	258	283	308
D	110.5	135.5	160.5	185.5	210.5	235.5	260.5	285.5
E	1	1	2	2	3	3	4	4
F	50.5	75.5	50.5	75.5	50.5	75.5	50.5	75.5
G	1	1	2	2	3	3	4	4
H	4	4	6	6	8	8	10	10
J	6	6	8	8	10	10	12	12
Weight (kg)	2.4	2.6	2.8	3.1	3.3	3.5	3.7	3.9

(\*1) An integrated motor/encoder cable is provided. (Refer to P. 34.)  
 (\*2) The slider will move to the ME after home return, so pay attention to possible contact with surrounding structures/parts.  
 ME: Mechanical end  
 SE: Stroke end

## Controllers

### Applicable Controllers

RCP3-series actuators can be operated with any of the following controllers. Select a controller type appropriate for your specific application.

Name	Appearance	Model	Feature	Maximum number of positioning points	Power-supply voltage	Power-supply capacity	Standard price	Reference page
Positioner type		PCON-C-42PI-NP-2-0	Up to 512 positioning points are supported	512	DC24V	2 A max.	—	→P31
Positioner type conforming to safety category		PCON-CG-42PI-NP-2-0						
Solenoid valve type		PCON-CY-42PI-NP-2-0	Operable with the same control you use when operating a solenoid valve	3				
Pulse-train input type (differential line driver specification)		PCON-PL-42PI-NP-2-0	Pulse-train input type supporting differential line driver	(-)				
Pulse-train input type (open collector specification)		PCON-PO-42PI-NP-2-0	Pulse-train input type supporting open collector					
Serial communication type		PCON-SE-42PI-N-0-0	Dedicated serial communication type	64				
Field network type		RPCON-42P	Dedicated field network type	768				
Program control type		PSEL-C-1-42PI-NP-2-0	Up to 2 axes can be operated using programs	1500				

\*With PSEL controllers, the above information applies to the 1-axis specification.

# RCA2-TA5R

ROBO Cylinder, Table Type, Actuator Width 55 mm, Servo Motor, Motor-reversing Specification

Model Name	<b>RCA2</b>	—	<b>TA5R</b>	—	<b>I</b>	—	<b>20</b>	—	<input type="checkbox"/>	—	<input type="checkbox"/>	—	<b>A1</b>	—	<input type="checkbox"/>	—	<input type="checkbox"/>
Specifications	Series	—	Type	—	Encoder type	—	Motor type	—	Lead	—	Stroke	—	Applicable controllers	—	Cable length	—	Options
	I: Incremental specification		20: Servo motor 20 W		10: 10 mm 5: 5 mm 2.5: 2.5 mm		25:25 mm s 100:100 mm (Set in 25-mm pitch)		A1: ACON ASEL		N: None P: 1 m S: 3 m M: 5 m		X <input type="checkbox"/> : Specified length		B: With brake LA: Power-saving feature ML: Motor reversed to left (standard) MR: Motor reversed to right NM: Counter-home specification		

\*Refer to P. 34 for the cables sold separately for maintenance purposes.

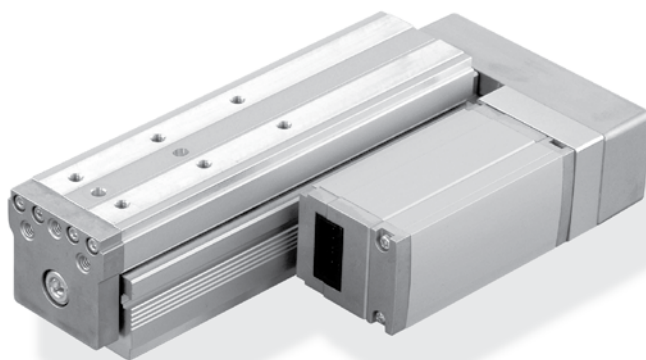

Power-saving feature

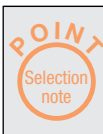

- (1) Take note that the maximum speed varies depending on whether the actuator is used horizontally or vertically.
- (2) The load capacities are based on operation at an acceleration of 0.3 G (or 0.2 G when the lead is 2.5 or the actuator is used vertically). The acceleration cannot be increased beyond this level.

### Actuator Specifications

#### Strokes and Maximum Speeds

Model	Motor output (W)	Lead (mm)	Maximum load capacity		Maximum push force (N)	Stroke (mm)
			Horizontal (kg)	Vertical (kg)		
RCA2-TA5R-I-20-10-①-A1-②-③	20	10	2	1	34	25 ~ 100 (Set in 25-mm pitch)
RCA2-TA5R-I-20-5-①-A1-②-③		5	3.5	2	68	
RCA2-TA5R-I-20-2.5-①-A1-②-③		2.5	5	3	137	

Explanation of codes: ① Stroke ② Cable length ③ Options

#### Strokes and Maximum Speeds

Stroke (mm)	25 ~ 100 (Set in 25-mm pitch)	
	Lead (mm)	Speed (mm/sec)
10	10	465 <400>
5	5	250
2.5	2.5	125

\*The value in < > applies when the actuator is used vertically. (Unit: mm/sec)

#### ① Price List by Stroke (Standard Prices)

① Stroke (mm)	Type code
	Encoder type
	Incremental
25	—
50	—
75	—
100	—

#### ② Price List by Cable Length (Standard Prices)

Type	Model	Standard price
Standard type (robot cable)	<b>P</b> (1m)	—
	<b>S</b> (3m)	—
	<b>M</b> (5m)	—
Special length	<b>X06</b> (6m) ~ <b>X10</b> (10m)	—
	<b>X11</b> (11m) ~ <b>X15</b> (15m)	—
	<b>X16</b> (16m) ~ <b>X20</b> (20m)	—
		—

\*Refer to P. 34 for the cables sold separately for maintenance purposes.

#### ③ Price List of Options (Standard Prices)

Name	Option code	Reference page	Standard price
With brake	<b>B</b>	—	—
Power-saving feature	<b>LA</b>	—	Free of charge
Motor reversed to left (standard)	<b>ML</b>	—	Free of charge
Motor reversed to right	<b>MR</b>	—	Free of charge
Counter-home specification	<b>NM</b>	—	Free of charge

#### Actuator Specifications

Item	Description
Drive method	Ball screw, $\phi 8$ mm, rolled C10
Positioning repeatability	$\pm 0.05$ mm
Lost motion	0.1 mm or less
Base	Material: Aluminum with dedicated alumite treatment
Dynamic allowable load moment (*1)	Ma: 6.57N·m Mb: 9.32N·m Mc: 14.32N·m
Overhang load length	Within the range of the applicable load moment
Surrounding air temperature/humidity	0 to 40°C, 85%RH or below (non-condensing)
Traveling life	5000km

(\*1) Refer to the RCP3/RCA2 Coupling Specification catalog for the moment load calculation.

Directions of allowable load moments

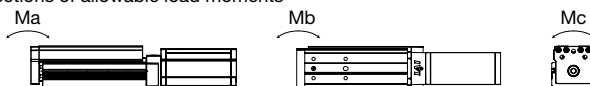



## Dimensions

CAD drawings can be downloaded from our website. [www.intelligentactuator.com](http://www.intelligentactuator.com)

2D CAD

\* Take note that with a 25-stroke model with brake, the motor unit extends from the end face of the table.

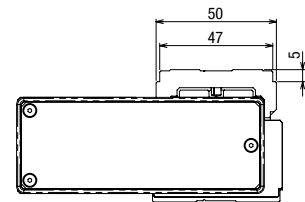
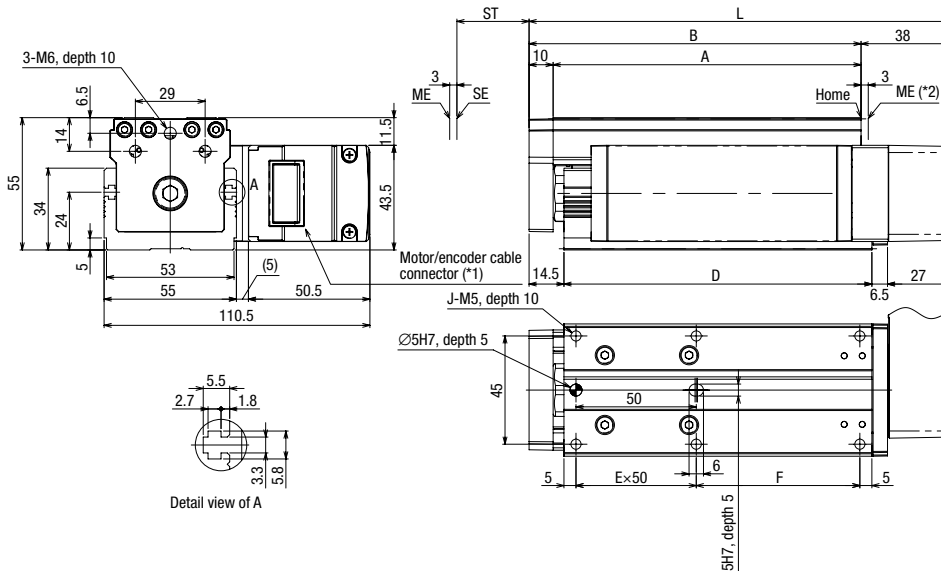
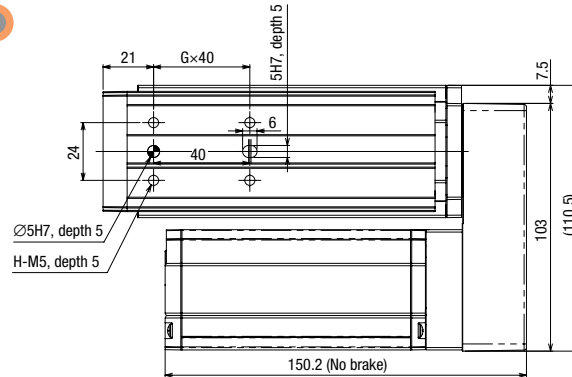
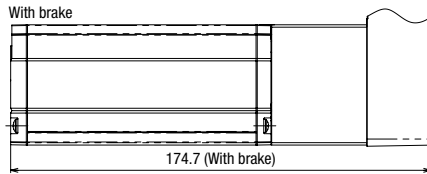

### Dimensions/Weights by Stroke

\*When a brake is equipped, the weight will increase by 0.3 kg

Stroke (mm)	25	50	75	100
L	151	176	201	226
A	103	128	153	178
B	113	138	163	188
D	103	128	153	178
E	1	1	2	2
F	43	68	43	68
G	1	1	2	2
H	4	4	6	6
J	6	6	8	8
Weight (kg)	1.4	1.6	1.7	1.9

(\*1) An integrated motor/encoder cable is provided. (Refer to P. 34.)

(\*2) The slider will move to the ME after home return, so pay attention to possible contact with surrounding structures/parts.

ME: Mechanical end  
SE: Stroke end

## Controllers

### Applicable Controllers

RCA2-series actuators can be operated with any of the following controllers. Select a controller type appropriate for your specific application.

Name	Appearance	Model	Feature	Maximum number of positioning points	Power-supply voltage	Power-supply capacity	Standard price	Reference page
Positioner type		ACON-C-20SI-NP-2-0	Up to 512 positioning points are supported	512	DC24V	5.1 A max. (The specific capacity varies depending on the actuator.)	—	→P31
Positioner type conforming to safety category		ACON-CG-20SI-NP-2-0						
Solenoid valve type		ACON-CY-20SI-NP-2-0	Operable with the same control you use when operating a solenoid valve	3				
Pulse-train input type (differential line driver specification)		ACON-PL-20SI-NP-2-0	Pulse-train input type supporting differential line driver	(-)				
Pulse-train input type (open collector specification)		ACON-PO-20SI-NP-2-0	Pulse-train input type supporting open collector					
Serial communication type		ACON-SE-20SI-N-0-0	Dedicated serial communication type	64				
Field network type		RACON-20S	Dedicated field network type	768				
Program control type		ASEL-C-1-20SI-NP-2-0	Up to 2 axes can be operated using programs	1500				

\*With ASEL controllers, the above information applies to the 1-axis specification.



## Dimensions

CAD drawings can be downloaded from our website. [www.intelligentactuator.com](http://www.intelligentactuator.com)

2D CAD

\* Take note that with a 25-stroke model with brake, the motor unit extends from the end face of the table.

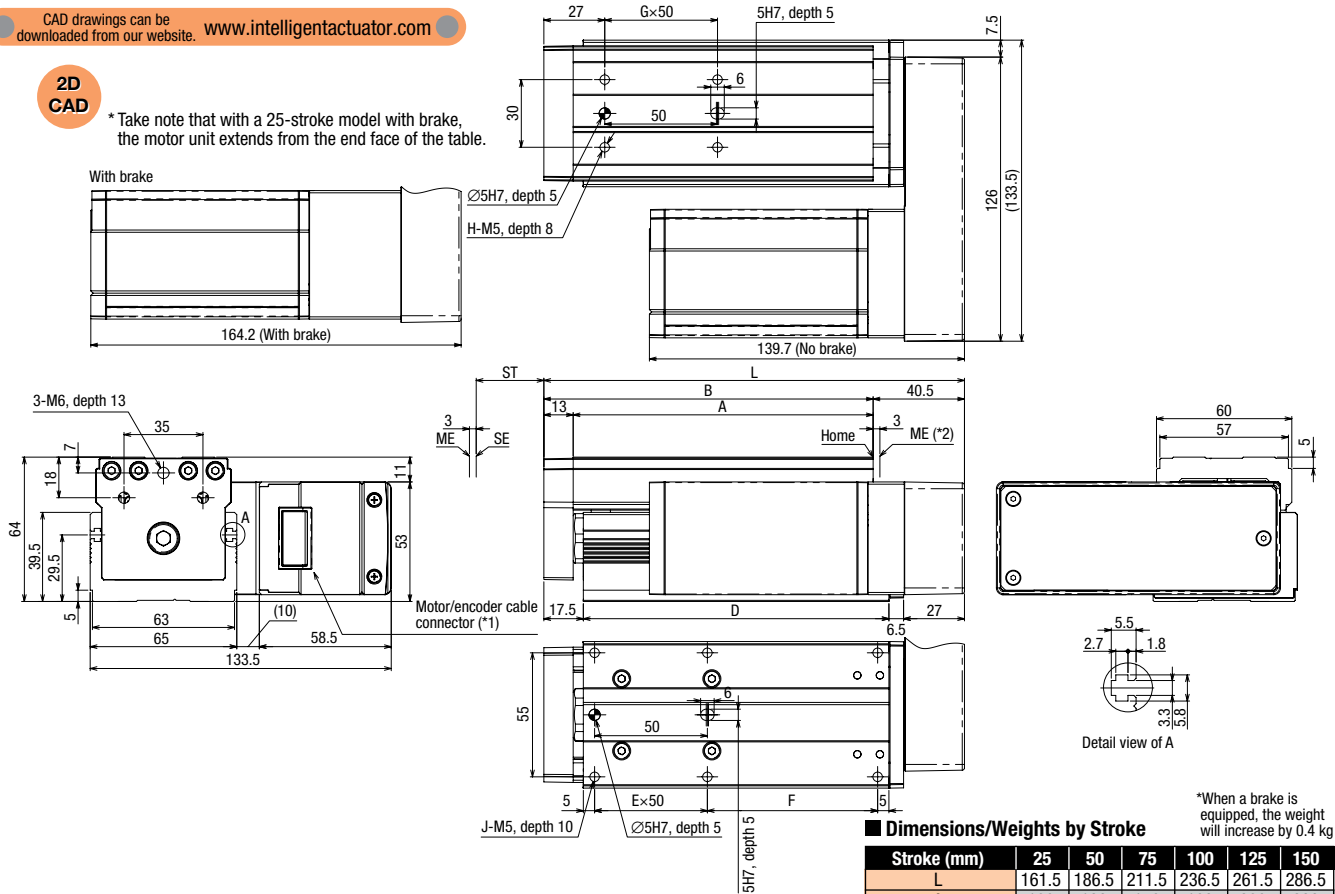

\*When a brake is equipped, the weight will increase by 0.4 kg

### Dimensions/Weights by Stroke

Stroke (mm)	25	50	75	100	125	150
L	161.5	186.5	211.5	236.5	261.5	286.5
A	108	133	158	183	208	233
B	121	146	171	196	221	246
D	110.5	135.5	160.5	185.5	210.5	235.5
E	1	1	2	2	3	3
F	50.5	75.5	50.5	75.5	50.5	75.5
G	1	1	2	2	3	3
H	4	4	6	6	8	8
J	6	6	8	8	10	10
Weight (kg)	2.1	2.3	2.5	2.7	2.9	3.1

(\*1) An integrated motor/encoder cable is provided. (Refer to P. 34.)  
 (\*2) The slider will move to the ME after home return, so pay attention to possible contact with surrounding structures/parts.  
 ME: Mechanical end  
 SE: Stroke end

## Controllers

### Applicable Controllers

RCA2-series actuators can be operated with any of the following controllers. Select a controller type appropriate for your specific application.

Name	Appearance	Model	Feature	Maximum number of positioning points	Power-supply voltage	Power-supply capacity	Standard price	Reference page
Positioner type		ACON-C-20I-NP-2-0	Up to 512 positioning points are supported	512	DC24V	5.1 A max. (The specific capacity varies depending on the actuator.)	—	→P31
Positioner type conforming to safety category		ACON-CG-20I-NP-2-0						
Solenoid valve type		ACON-CY-20I-NP-2-0	Operable with the same control you use when operating a solenoid valve	3				
Pulse-train input type (differential line driver specification)		ACON-PL-20I-NP-2-0	Pulse-train input type supporting differential line driver	(-)				
Pulse-train input type (open collector specification)		ACON-PO-20I-NP-2-0	Pulse-train input type supporting open collector					
Serial communication type		ACON-SE-20I-N-0-0	Dedicated serial communication type	64				
Field network type		RACON-20	Dedicated field network type	768				
Program control type		ASEL-C-1-20I-NP-2-0	Up to 2 axes can be operated using programs	1500				

\*With ASEL controllers, the above information applies to the 1-axis specification.



## Dimensions

CAD drawings can be downloaded from our website. [www.intelligentactuator.com](http://www.intelligentactuator.com)

2D CAD

\* Take note that with a 25-stroke model with brake, the motor unit extends from the end face of the table.

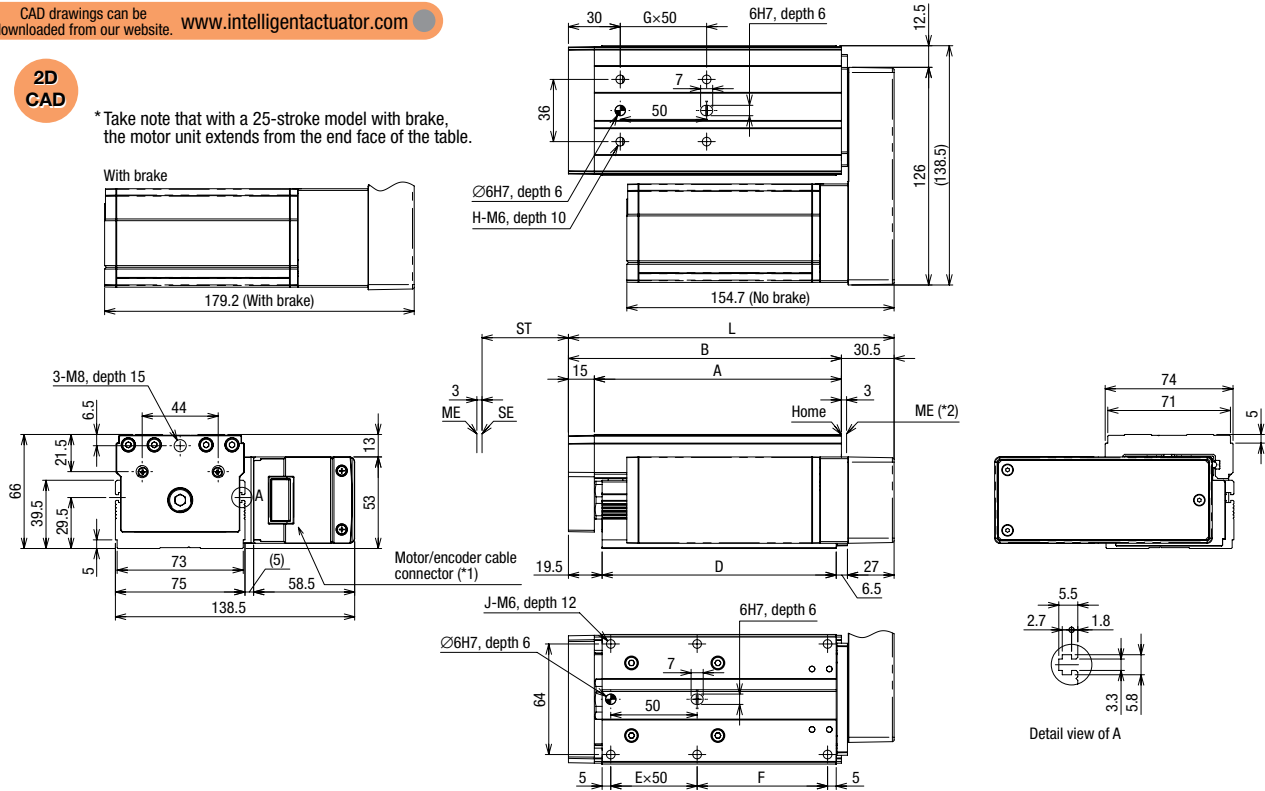

### Dimensions/Weights by Stroke

\*When a brake is equipped, the weight will increase by 0.4 kg

Stroke (mm)	25	50	75	100	125	150	175	200
L	163.5	188.5	213.5	238.5	263.5	288.5	313.5	338.5
A	118	143	168	193	218	243	268	293
B	133	158	183	208	233	258	283	308
D	110.5	135.5	160.5	185.5	210.5	235.5	260.5	285.5
E	1	1	2	2	3	3	4	4
F	50.5	75.5	50.5	75.5	50.5	75.5	50.5	75.5
G	1	1	2	2	3	3	4	4
H	4	4	6	6	8	8	10	10
J	6	6	8	8	10	10	12	12
Weight (kg)	2.4	2.6	2.8	3.1	3.3	3.5	3.7	3.9

(\*1) An integrated motor/encoder cable is provided. (Refer to P. 34.)  
 (\*2) The slider will move to the ME after home return, so pay attention to possible contact with surrounding structures/parts.  
 ME: Mechanical end  
 SE: Stroke end

## Controllers

### Applicable Controllers

RCA2-series actuators can be operated with any of the following controllers. Select a controller type appropriate for your specific application.

Name	Appearance	Model	Feature	Maximum number of positioning points	Power-supply voltage	Power-supply capacity	Standard price	Reference page
Positioner type		ACON-C-30I-NP-2-0	Up to 512 positioning points are supported	512	DC24V	5.1 A max. (The specific capacity varies depending on the actuator.)	—	→P31
Positioner type conforming to safety category		ACON-CG-30I-NP-2-0						
Solenoid valve type		ACON-CY-30I-NP-2-0	Operable with the same control you use when operating a solenoid valve	3				
Pulse-train input type (differential line driver specification)		ACON-PL-30I-NP-2-0	Pulse-train input type supporting differential line driver	(-)				
Pulse-train input type (open collector specification)		ACON-PO-30I-NP-2-0	Pulse-train input type supporting open collector					
Serial communication type		ACON-SE-30I-N-0-0	Dedicated serial communication type	64				
Field network type		RACON-30	Dedicated field network type	768				
Program control type		ASEL-C-1-30I-NP-2-0	Up to 2 axes can be operated using programs	1500				

\*With ASEL controllers, the above information applies to the 1-axis specification.

## RCP3/RCA2 Controllers

Model List/Prices							
Model	PCON/ACON					RPCON PACON (ROBONET)	PSEL/ASEL
	C	CG	CY	PL/PO	SE		
Name	Positioner type	Safety category type	Solenoid valve type	Pulse-train control type	Serial communication type	Field network type	Program type
Appearance							
Feature	Positioner controller supporting up to 512 positioning points	Specification conforming to safety category	Operable with the same control you use when operating an air cylinder	Freely controllable using pulse trains	Dedicated controller for serial communication	Operable via DeviceNet, CC-Link or Profibus	Capable of operating an actuator via programs using the built-in sequence function
Price	-	-	-	-	-	- (*1)	- (*2)

(\*1) A gateway unit (sold separately) is required for RPCON/ACON controllers. (\*2) 1-axis specification.

### Model

#### [PCON/ACON Controllers]

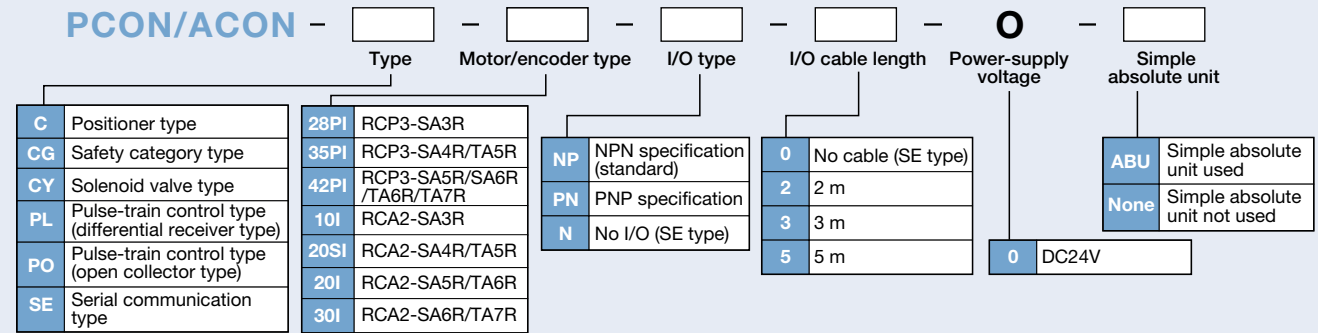

#### [RPCON Controllers]

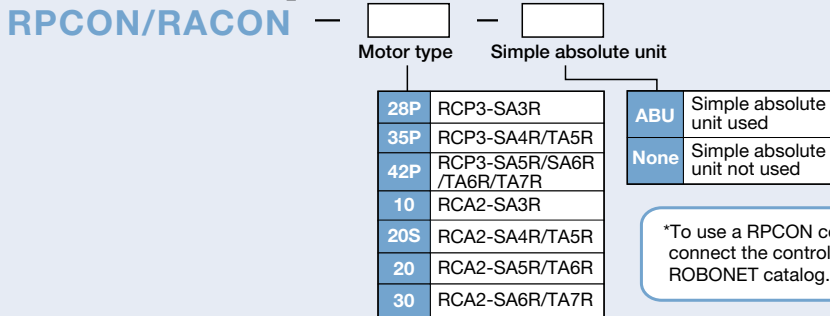

#### [PSEL Controllers]

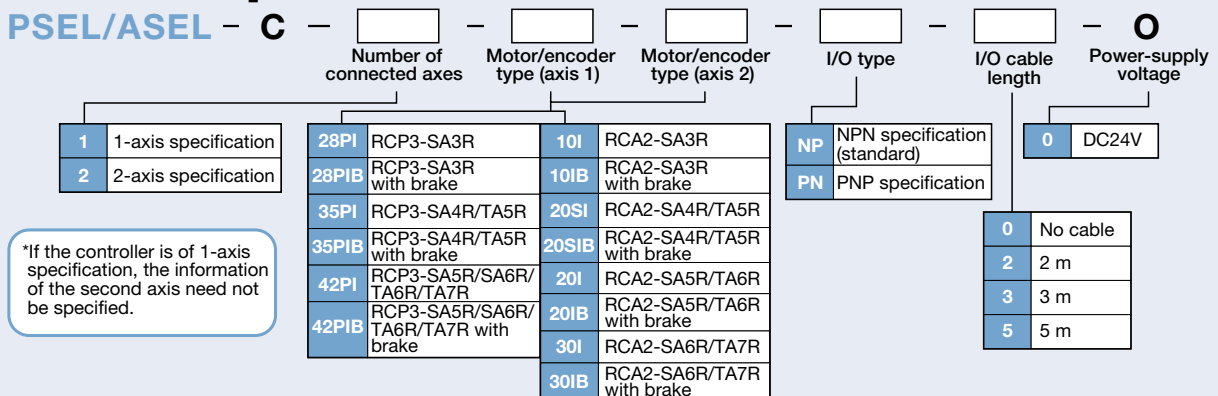



## Specification Table

Item	Specification						
	PCON/ACON					RPCON/RACON (ROBONET)	PSEL/ASEL
Controller type	C	CG	CY	PL	PO	SE	
Maximum number of controlled axes	1 axis					Up to 16 axes can be linked and operated	2 axes
Operation method	Positioner type		Solenoid valve	Pulse-train input type		Serial communication type	Field network
Number of positioning points	512		3	-		64	768
I/O connector	40-pin connector		12-pin connector	14-pin connector		-	34-pin connector
Number of I/O points	16 input points/ 16 output points		4 input points/ 6 output points	4 input points/4 output points		-	24 input points/ 8 output points
Serial communication	RS485 (Modbus RTU)						RS232
Peripheral communication cable	CB-PAC-PIO□□□□		CB-PACY-PIO□□□□	CB-PACPU-PIO□□□□		CB-RCB-CTL002	-
Command-pulse input method	-			Differential line driver	Open collector	-	
Maximum input pulse frequency	-			200 kpps	60 kpps	-	
Position detection method	Incremental encoder						
Motor/encoder cable	CB-PCS-MPA□□□□(PCON)/CB-ACS-MPA□□□□(ACON) (up to 20 m)						
Input power supply	DC24V±10%						
Power-supply capacity	RCP3 (all models)		2 A max.			2 A max. (*1)	5.5 A max.
	RCA2	SA5 TA6 (20W)	1.3 A rated / 4.4 A max. (standard specification) 1.3 A rated / 2.5 A max. (power-saving specification)		(*)2	(*)3	
		SA3, SA6 TA7 (30W)	1.3 A rated / 4.0 A max. (standard specification) 1.3 A rated / 2.2 A max. (power-saving specification)		(*)2	(*)3	
		SA4, TA5 (20W)	1.3 A rated / 5.1 A max. (standard specification) 1.3 A rated / 3.4 A max. (power-saving specification)		(*)2	(*)3	
Withstand voltage	DC500V 1 MΩ						500 VDC, 10 MΩ or more
Surrounding air temperature/ humidity and environment	0 to 40°C, 10 to 95% (non-condensing); not subject to corrosive gasses						
Protection degree	IP20						
Weight	Approx. 300 g		Approx. 130 g			Approx. 200 g	Approx. 450 g

(\*1) The current consumed during operation is the sum of (2 A x Number of controllers used) and the current consumption of the gateway unit (approx. 0.6 A).

(\*2) The required power-supply capacity of a RACON controller is the sum of (Power-supply capacity of ACON x Number of controllers used) and the current consumption of the gateway unit (approx. 0.6 A).

(\*3) The required power-supply capacity of an ASEL controller is the sum of (Power-supply capacity of ACON x Number of controllers used) and the control power-supply current (approx. 1.2 A).

## External Dimensions

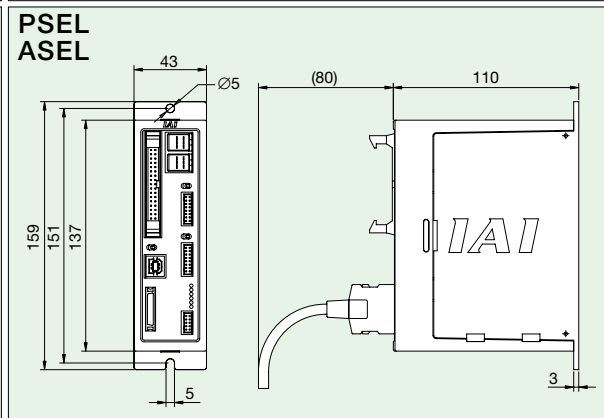
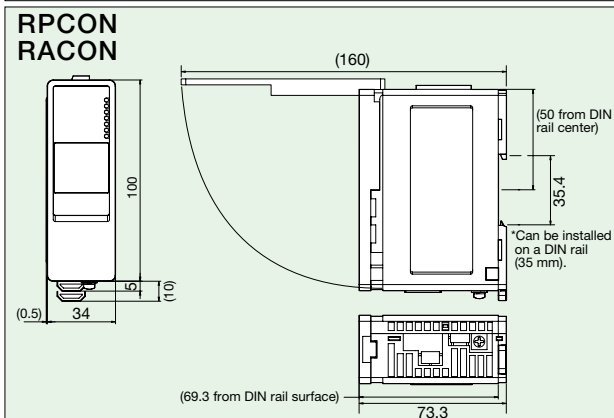
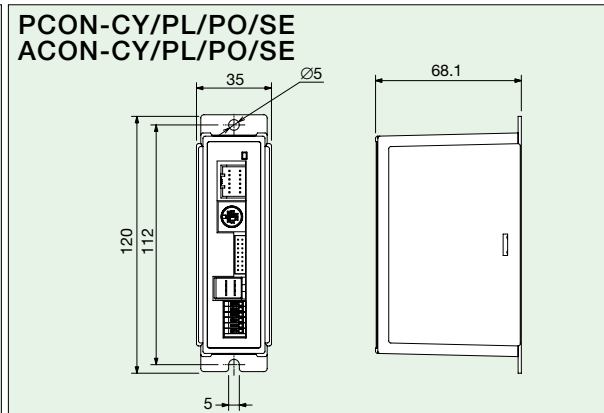
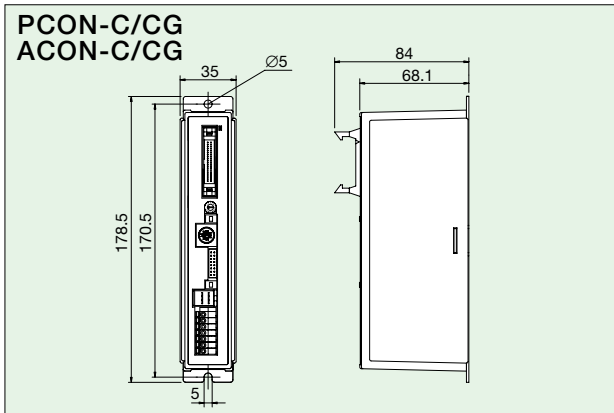

## Controller Options

**[Teaching Pendants]** These teaching devices offer functions to input positions, conduct test operation, perform monitoring, and more.

Item	RCM-E	RCM-P	CON-T	SEL-T-J	SEL-TD-J
External dimensions					
Applicable controllers	PCON/ACON/RPCON/RACON			PSEL/ASEL	
Position input	○	○	○	○	○
Program input	×	×	×	○	○
Actuator operation	○	×	○	○	○
Display	LCD display of 16 characters x 2 lines			LCD display of 20 characters x 4 lines	
3-position enable switch	×	×	×	×	○
ANSI compliance	×	×	×	×	○
CE Mark compliance	×	×	○	○	○
UL compliance	×	×	×	×	○
Cable length	5m				
Surrounding air temperature/humidity	Temperature: 0 to 40°C / Humidity: 85%RH or below				
Protection degree	—			IP54	
Weight	Approx. 400 g	Approx. 360 g	Approx. 400 g	Approx. 400 g	Approx. 400 g
Standard price	—	—	—	—	—

**[PC Software (for Windows)]** Features Offering functions to input programs/positions, conduct test operation, perform monitoring, and more, these software programs assist you in the startup of your system. The debugging function has been enhanced to shorten the startup time further.

### [PCON/ACON/RPCON/RACON PC Software (RS232 Connection Type)]

- Model RCM-101-MW (with external device communication cable + RS232 conversion unit)
- Configuration

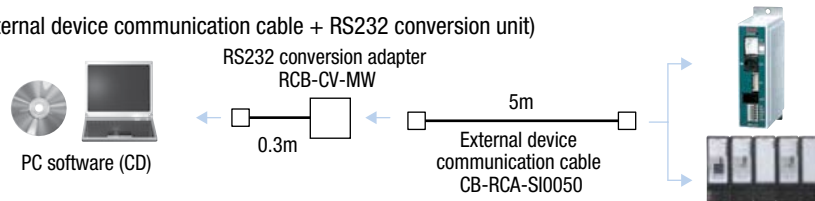

### [PCON/ACON/RPCON/RACON PC Software (USB Connection Type)]

- Model RCM-101-USB (with external device communication cable + USB conversion adapter + USB cable)
- Configuration

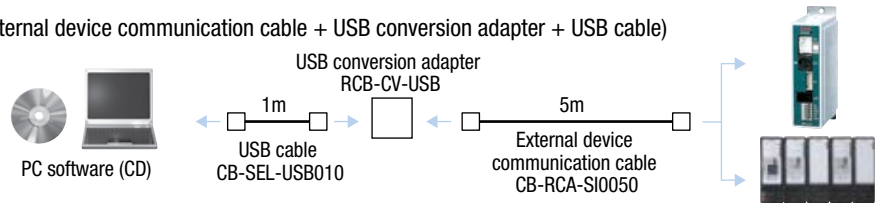

### [PSEL/ASEL PC Software (RS232 Connection Type)]

- Model IA-101-X-MW-J (with RS232C cable + connector conversion cable)
- Configuration

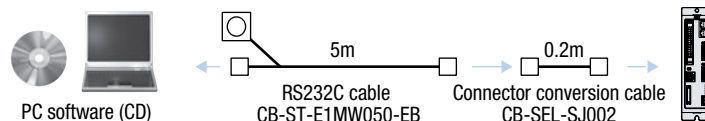

### [PSEL/ASEL PC Software (USB Connection Type)]

- Model IA-101-X-USB (with USB cable)
- Configuration

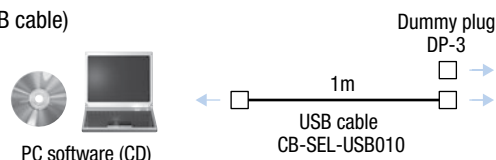

Maintenance Parts

[Motor/Encoder Cables]

RCP3 Motor/Encoder Cables

Model **CB-PCS-MPA**

\*Indicate a desired cable length (L) up to 20 m in     
Example) 080 = 8 m

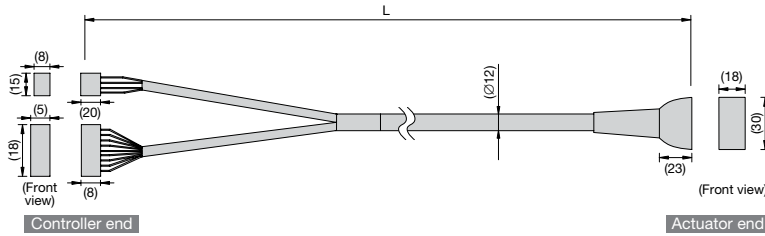

Signal	Pin number	(Cable color)	Pin number	Signal
A	B1	Black	A1	A
VMM	A2	White	B1	VMM
/A	A1	Red	A2	/A
B	B3	Green	B2	B
VMM	B2	Yellow	A3	VMM
/B	A3	Brown	B3	/B
			A4	NC
			B4	NC
			A5	BK+
			B5	BK-
			A6	LS+
			B6	LS-
			A7	A+
			B7	A-
			A8	B+
			B8	B-
			A9	NC
			B9	VPS
			A10	VCC
			B10	GND
			A11	NC
			B11	FG
BK+	14	Pink (red dot)		
BK-	13	Pink (blue dot)		
LS+	16	White (red dot)		
LS-	15	White (blue dot)		
A+	12	Orange (red dot)		
A-	11	Orange (blue dot)		
B+	10	Gray (red dot)		
B-	9	Gray (blue dot)		
NC	8			
VPS	7	Orange (continuous blue dots)		
VCC	6	Gray (continuous red dots)		
GND	5	Gray (continuous blue dots)		
NC	4			
FG	1	Shield		

RCA2 Motor/Encoder Cables

Model **CB-ACS-MPA**

\*Indicate a desired cable length (L) up to 20 m in     
Example) 080 = 8 m

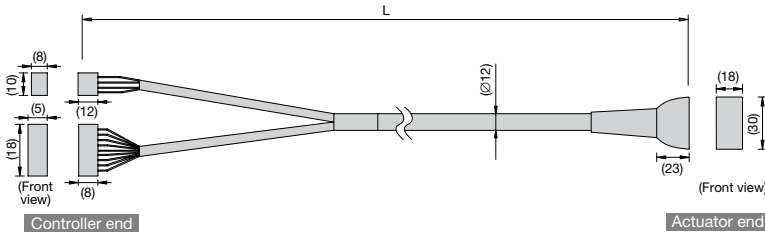

Signal	Pin number	(Cable color)	Pin number	Signal
U	1	Red	A1	U
V	2	Yellow	B1	V
W	3	Black	A2	W
			B2	NC
			A3	NC
			B3	NC
			A4	BK+
			B4	BK-
			A5	LS+
			B5	LS-
			A6	A+
			B6	A-
			A7	B+
			B7	B-
			A8	Z+
			B8	Z-
			A9	-
			B9	/PS
			A10	VCC
			B10	GND
			A11	NC
			B11	FG
BK+	16	Yellow (red dot)		
BK-	15	Yellow (blue dot)		
LS+	18	Pink (red dot)		
LS-	17	Pink (blue dot)		
A+	14	White (red dot)		
A-	13	White (blue dot)		
B+	12	Orange (red dot)		
B-	11	Orange (blue dot)		
Z+	10	Gray (red dot)		
Z-	9	Gray (blue dot)		
-	8	Orange (continuous red dots)		
/PS	7	Orange (continuous blue dots)		
VCC	6	Gray (continuous red dots)		
GND	5	Gray (continuous blue dots)		
NC				
FG	1	Shield		

[Motor Units]

Axis type		Motor Units				
		No brake		With brake		
		Model	Standard price	Model	Standard price	
RCP3	Slider type	SA3R	RCP3-MU1B	-	RCP3-MU1B-B	-
		SA4R	RCP3-MU2B	-	RCP3-MU2B-B	-
		SA5R	RCP3-MU3B	-	RCP3-MU3B-B	-
	Table type	SA6R	RCP3-MU3B	-	RCP3-MU3B-B	-
		TA5R	RCP3-MU2B	-	RCP3-MU2B-B	-
		TA6R	RCP3-MU3B	-	RCP3-MU3B-B	-
RCA2	Slider type	SA3R	RCA2-MU1B	-	RCA2-MU1B-B	-
		SA4R	RCA2-MU2B	-	RCA2-MU2B-B	-
		SA5R	RCA2-MU3B	-	RCA2-MU3B-B	-
	Table type	SA6R	RCA2-MU4B	-	RCA2-MU4B-B	-
		TA5R	RCA2-MU2B	-	RCA2-MU2B-B	-
		TA6R	RCA2-MU3B	-	RCA2-MU3B-B	-
		TA7R	RCA2-MU4B	-	RCA2-MU4B-B	-



**IAI America, Inc.**

Head Office: 2690W 237th Street, Torrance, CA 90505 (800) 736-1712  
Chicago Office: 1261 Hamilton Parkway, Itasca, IL 60143 (800) 944-0333  
Atlanta Office: 1220 Kennestone Circle, Suite E, Marietta, GA 30066 (888) 354-9470

**IAI Industrieroboter GmbH**

Ober der Röth 4, D-65824 Schwalbach am Taunus, Germany

**IAI (Shanghai) Co., Ltd.**

SHANGHAI JIAHUA BUSINESS CENTER A8404.808  
Hongqiao Rd. Shanghai 20030, China

[www.intelligentactuator.com](http://www.intelligentactuator.com)

Due to product improvement, specifications subject to change without notice.

