

IMA

INTEGRATED MOTOR
ROD-STYLE ACTUATOR

ENDURANCE TECHNOLOGY™



LINEAR MOTION MADE EASY

What is the IMA?

The IMA is a compact, durable, high force rod-style actuator. The IMA integrates a servo motor with a proven mechanical design to provide efficient high force in a compact lightweight design envelope. Our patent-pending design allows for easy re-lubrication without disassembly for extremely long service life.

Tolomatic has over 50 years of experience manufacturing rodless and rod-style electric and pneumatic actuators. The IMA combines this experience and the power of servo motor technology into one actuator. The result: reliable, affordable power in a compact package.



Features:

- Compact, lightweight design
- Long life
- High force
- High positional accuracy
- High efficiency
- Proven performance
- Flexibility
- Compatibility
- Low inertia

Eliminates:

- Couplers
- Adapters
- Belts
- Gears
- Unneeded assembly labor
- Forced air or water cooling
- Hydraulic systems
- Pneumatic systems
- Need for multiple vendors

**PATENT
PENDING
SCREW
LUBRICATION
SYSTEM**



Look For:

ENDURANCE TECHNOLOGYSM

Endurance Technology features are designed for maximum durability to provide extended service life. This endurance technology symbol indicates our durability design features.

CONTENTS

What is the IMA?.....	2	IMA Specs & Performance	6-8	Selection Guidelines	14
IMA Applications.....	3	IMA Dimensions	9-12	Ordering	15
IMA Features	4	Application Data Worksheet ...	13		

IMA - Integrated Motor Actuator

IMA Applications

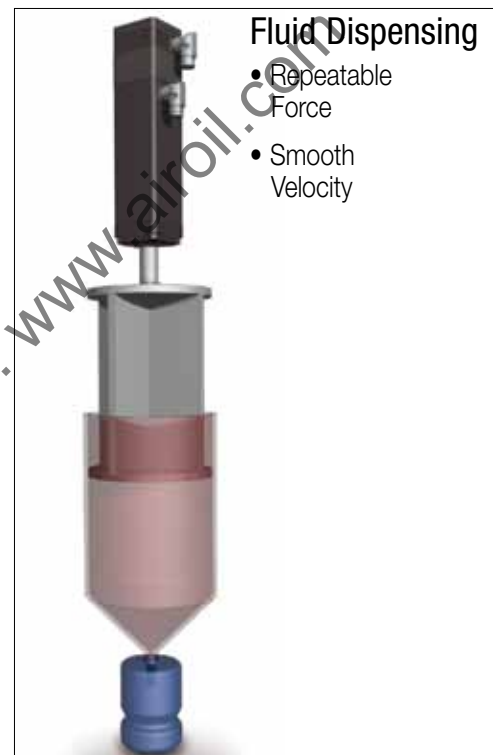
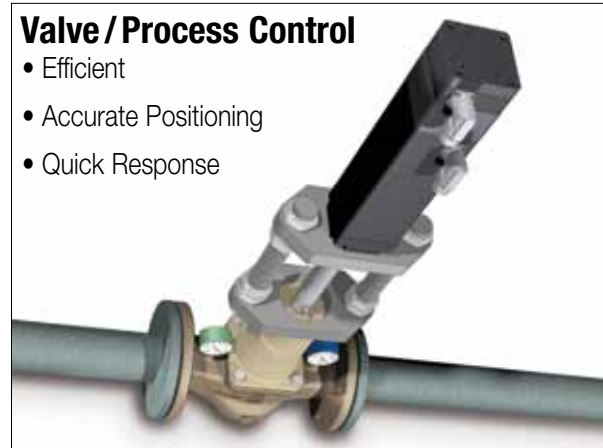

Other Applications:

- Animation
- Assembly
- Automated assembly
- Automatic tool changers
- Automotive
- Clamping
- Converting
- Conveyors
- Cycle testing
- Fillers
- Formers
- Hydraulic replacement
- Laser positioning
- Machine tools
- Material handling systems
- Medical equipment
- Molding
- Motion simulators
- Open / close doors
- Packaging equipment
- Parts clamping
- Patient lifts
- Pick & place
- Pneumatic replacement
- Precision grinders
- Product test simulations
- Riveting / fastening / joining
- Robot manipulator arms
- Sawmill equipment
- Semiconductor
- Stage motion control
- Stamping
- Table positioning
- Tension control
- Test stands
- Tube bending
- Volumetric pumps
- Water jet control
- Wave generation
- Web guidance
- Welding
- Wire winding

IMA INTEGRATED MOTOR ACTUATOR

ENDURANCE TECHNOLOGYSM

Endurance Technology features are designed for maximum durability to provide extended service life.

MULTIPLE SCREW TECHNOLOGIES

YOU CAN CHOOSE:

- Ball nuts offer positioning accuracy and repeatability
- Roller nuts (coming soon) provide the highest thrust and life ratings available



REPLACEABLE

BEARING CARTRIDGE

- Doubles as a locating pilot for positioning actuator

INTERNAL BUMPERS

- Bumpers protect the screw and nut assembly from damage at end of stroke

ROD WIPER

- Prevents contaminants from entering the actuator for extended life

GREASE PORT

- Patent pending screw relubrication system provides extended screw service life
- Convenient lubrication without disassembly

INTEGRAL MOUNTING

- Four threaded holes on front face are available for direct mounting or addition of customized options

THREADED ROD END

- Zinc plated alloy steel construction for corrosion resistance
- Provides a common interface to multiple rod end options

SALT BATH NITRIDE TREATED THRUST TUBE

- Steel thrust tube supports extremely high force capabilities
- Salt bath nitride treatment provides excellent corrosion resistance, surface hardness and is very resistant to adherence of weld slag, water and other potential contaminants

LIGHTWEIGHT ALUMINUM DESIGN

- Black anodized extrusion design is optimized for rigidity and strength

IMA

SPECIFICATIONS: pg. 6
SIZES

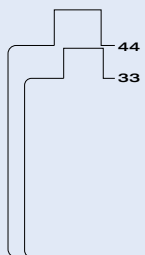

MAXIMUM

STROKE: 18"

THRUST: 2,000 lbf

SPEED: 23 in/sec

COMPLETE INFORMATION:

www.tolomatic.com

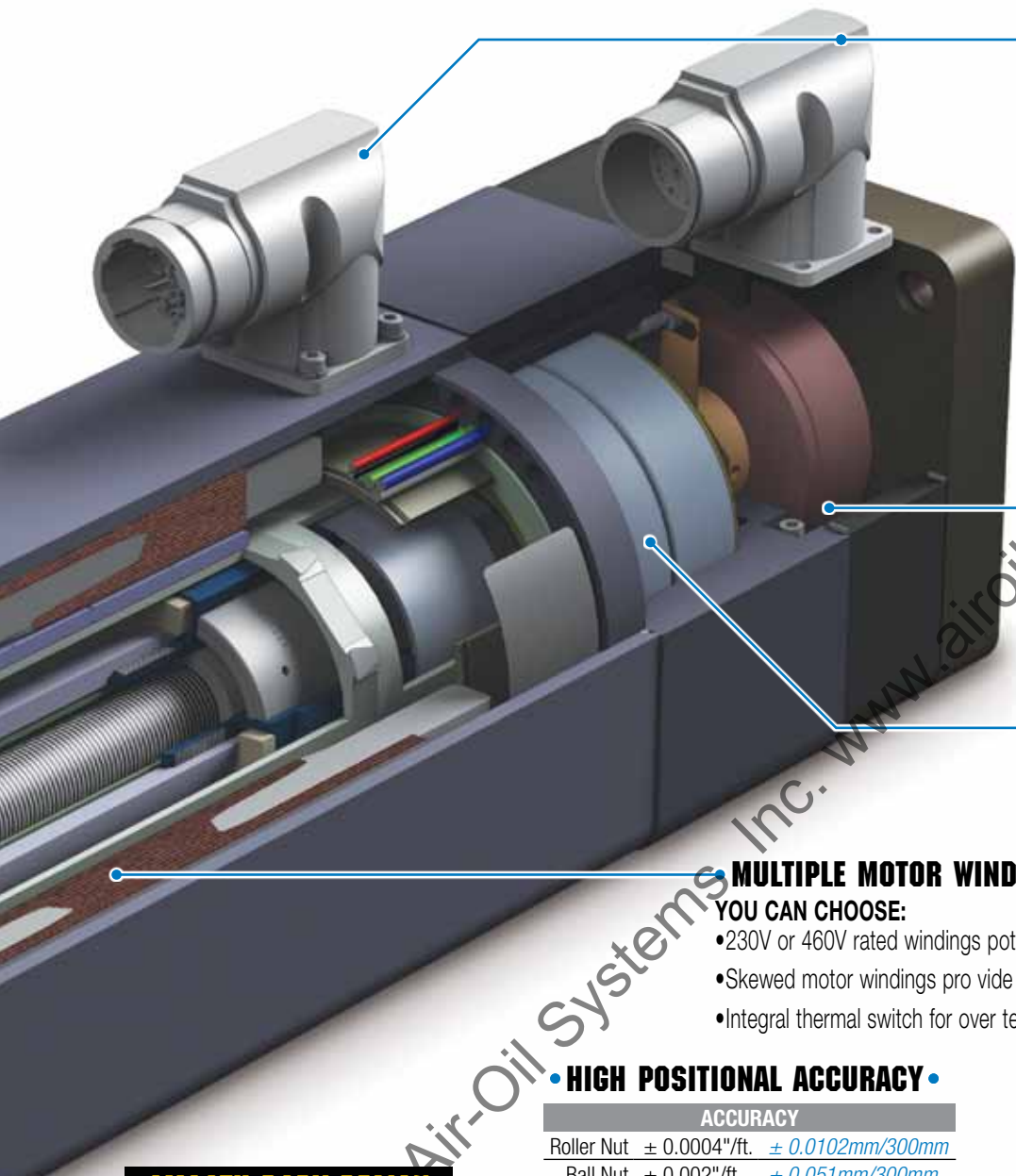

CONNECTORS YOU CAN CHOOSE FROM:

- Connector choice and wiring emulates popular motor manufacturers for compatibility:
 - Tolomatic Standard
 - Bosch Rexroth MSK Series
 - Emerson FM & NT Series
 - Lenze MCA Series
 - more to come...

- STAGGERED CONNECTORS for more convenient installation

- 270° Rotatable & Box mount options available

HIGH RESOLUTION FEEDBACK

YOU CAN CHOOSE:

- Digital encoder
- Multi-turn absolute encoder
- Resolver

HIGH THRUST BEARING

- Provides complete support of screw and protects the feedback device from linear forces

MULTIPLE MOTOR WINDINGS

YOU CAN CHOOSE:

- 230V or 460V rated windings potted directly into actuator housing
- Skewed motor windings provide minimal torque ripple for smooth linear motion
- Integral thermal switch for over temperature protection

HIGH POSITIONAL ACCURACY

ACCURACY

Roller Nut	± 0.0004"/ft.	± 0.0102mm/300mm
Ball Nut	± 0.002"/ft.	± 0.051mm/300mm

SMOOTH BODY DESIGN

- Eliminates potential contaminant collection points



Modifications:

- Contact Tolomatic for Stainless Steel, Food Grade or Mil-Spec versions of the IMA

OPTIONS

MOUNTING

- Front Face - Standard
- Side Mounting Holes, 2 sides & bottom (no photo)
- Mounting Plates
- Rear Clevis
- Front Flange
- Trunnion, Rear or Front

ROD END

- Internal Thread - Standard
- External Threads
- Clevis
- Spherical Eye
- Alignment Coupler

BRAKE

- 24V Spring held / electronically released

- IP67 • For protection against water and dust ingress

CABLES

- Signal Cable (6m)
- Power Cable (6m)

- ARO • Anti-Rotate

IMA - Integrated Motor Actuator

Performance & Mechanical Specifications:

SERIES		IMA33	IMA44		
SIZE	in	3.3	4.4		
	mm	83.0	110.0		
STROKE	in	6.0 to 18.0			
	mm	152.4 to 457.2			
NUT/SCREW		BN05	BN10	BN05	BN10
SCREW LEAD	in	0.197	0.394	0.197	0.394
	mm	5.0	10.0	5.0	10.0
DYNAMIC LOAD RATING (1 mil revs)	lbf	1709	1214	3395	3372
	N	7602	5400	15100	15000
LEAD ACCURACY	in/ft	0.002			
	mm/300	0.051			
BACKLASH	in	0.004	0.004	0.005	0.005
	mm	0.10	0.10	0.13	0.13
CONT. THRUST	lbf	850	425	1650	825
	N	3781	1891	7340	3670
PEAK THRUST	lbf	1000	850	2000	1650
	N	4448	3781	8896	7340
MAX. VELOCITY	in/sec	11	22	11	22
	mm/sec	279	559	279	559
TEMP RANGE	°F	50 to 122			
	°C	10 to 50			
IP RATING	Standard IP65, Optional IP67				
**BASE WEIGHT	lb	14.1	28.6		
	kg	6.4	13.0		
WEIGHT PER UNIT OF STROKE	lb/in	0.6603	1.1035		
	kg/mm	0.0118	0.0197		
**BASE INERTIA	lb-in ²	1.649	1.653	3.311	3.321
	kg-cm ²	4.826	4.837	9.689	9.719
INERTIA PER UNIT OF STROKE	lb-in ² /in	0.003	0.003	0.018	0.019
	kg-cm ² /mm	0.0003	0.0004	0.0021	0.0022
BREAKAWAY TORQUE	in-lb	2.4	2.3	4.3	3.6
	N-m	0.271	0.260	0.486	0.407
BACK DRIVE FORCE*	lbf	60	28	100	44
	N	267	126	445	196

*In vertical applications an unpowered IMA will require a brake to maintain position if the load on the actuator exceeds this value

**Value given is for a zero stroke actuator

MAKE THE RIGHT CHOICE!

Tolomatic's sizing software is a great tool to help choose the right IMA. OR Contact Tolomatic for assistance in choosing the correct IMA actuator and options required for your application.

Motor Specifications:

SERIES		IMA33	IMA44		
VOLTAGE		MV23	MV43	MV23	MV43
TORQUE CONSTANT (K _t)	in-lb/A Peak	5.5	10.7	5.4	10.6
	N-m/A Peak	0.62	1.21	0.61	1.20
VOLTAGE CONSTANT (K _e)	V/Krpm Peak	79.8	154	78.1	153.1
CONTINUOUS STALL TORQUE	in-lb	35	34	67	67
	N-m	4.0	3.8	7.6	7.6
CONTINUOUS STALL CURRENT	Arms	4.5	2.25	8.8	4.5
PEAK TORQUE	in-lb	70	68	134	
	N-m	7.9	7.7	15.2	
PEAK CURRENT	Arms	9	4.5	17.6	9.0
RESISTANCE	Ohms	2.07	8.3	0.58	2.32
INDUCTANCE	mH	3.8	15	2.75	11.5
NO. OF POLES	8				
BUS VOLTAGE	Vrms	230	460	230	460
SPEED @ RATED V	RPM	3500			

 RoHS Compliant Components, **UL** **CE** Approval Pending

 NOTE: Both IMA33 and IMA44 actuators were characterized using an aluminum face mount plate (8.25" x 7.0" x 0.7")

Brake Specifications:

SERIES		IMA33	IMA44
ROTOR INERTIA	oz-in ²	0.112	0.656
	gm-cm ²	20.5	120.0
CURRENT	Amp	0.516	0.67
HOLDING TORQUE	in-lb	35	80
	N-m	4.0	9.0
ENGAGE TIME	mSec	20	50
DISENGAGE TIME	mSec	70	40
VOLTAGE	Vdc	24	24



FREE - Windows® compatible software, download at www.tolomatic.com

Or Call 1-800-328-2174 for Excellent Customer Service & Technical Support

IMA - Integrated Motor Actuator

SPEED vs THRUST IMA33

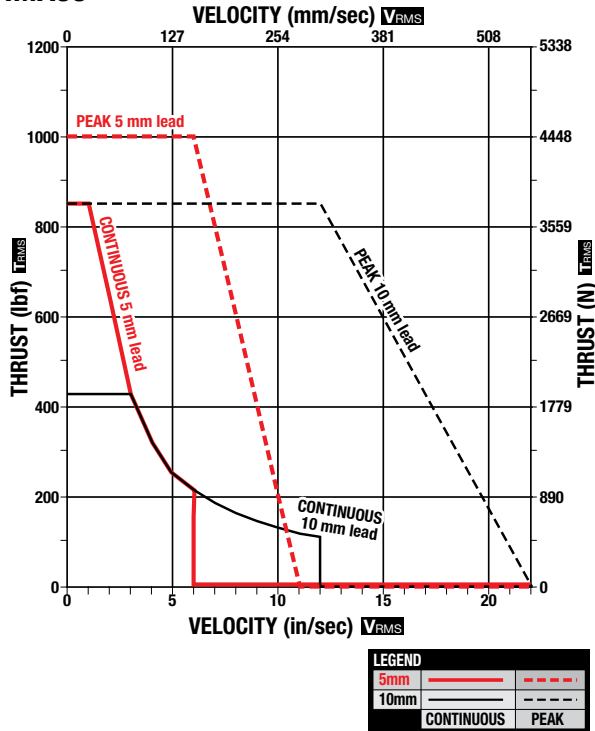

IMA44

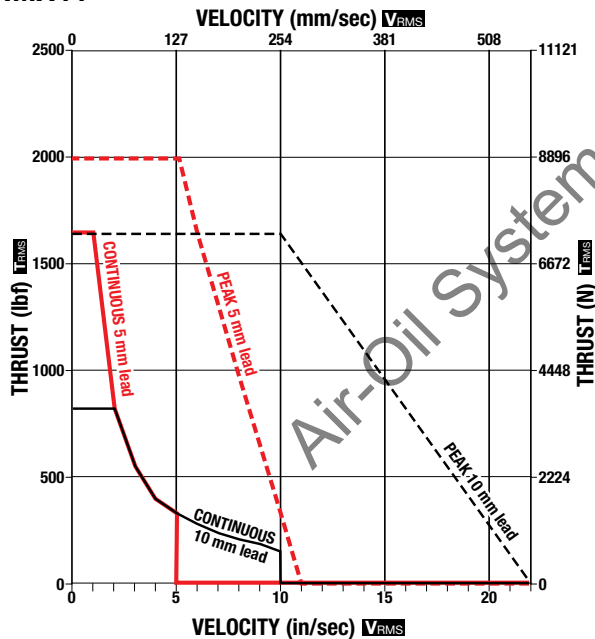

CALCULATING RMS THRUST AND VELOCITY

Servo motor actuator systems have two speed/thrust curves: one for continuous duty operation and another for intermittent (peak) duty. A servo system can be selected according to the total thrust and maximum velocity indicated by the continuous duty curve. However, by calculating the root mean square (RMS) thrust based on the application duty cycle, you may be able to take advantage of the higher peak thrust available in the intermittent duty range. The RMS thrust must fall within the continuous duty region of the motor/drive and the application maximum thrust must fall under the peak thrust of the actuator. Use the following formulae when calculating the RMS thrust and velocity. When selecting an integrated servo actuator system, it is necessary to add a margin of safety to the thrust and velocity required to move the load. The recommended margin for servo motors is 15%.

$$T_{RMS} = \sqrt{\frac{\sum (T_i^2 \times t_i)}{\sum (t_i)}}$$

$$V_{RMS} = \sqrt{\frac{\sum (V_i^2 \times t_i)}{\sum (t_i)}}$$

Where:

T_{RMS} = RMS Thrust

V_{RMS} = RMS Velocity

T_i = Thrust during interval i

V_i = Velocity during interval i

t_i = Time interval i

BRAKE CONSIDERATIONS

An unpowered IMA will require a brake to maintain its position if the force on the actuator exceeds Back Drive Force listed in the table on page 6.

A brake can be used with the actuator to keep it from back-driving, typically in vertical applications. A brake may be used for safety reasons or for energy savings allowing the actuator to hold position when unpowered. See page 15 for ordering information.

NOTE: The optional Spring-Applied/Electronically-Released Brake requires 24V power. Input current rating: IMA33 - 0.516 Amps; IMA44 - 0.67 Amps.

QUESTIONS?

Contact Tolomatic for assistance in choosing the correct IMA actuator and options required for your application.

IMA - Integrated Motor Actuator

CRITICAL SPEED

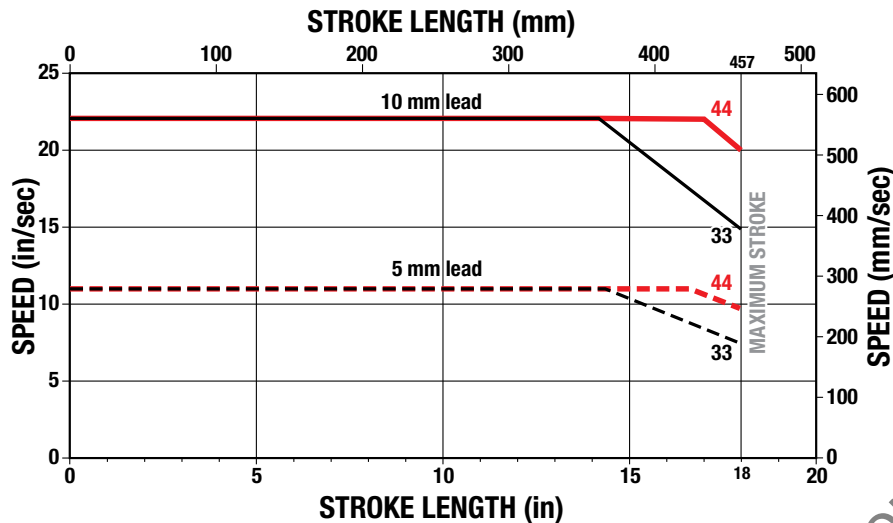

NOTE: The L_{10} expected life of a ball screw linear actuator is expressed as the linear travel distance that 90% of properly maintained ball screws manufactured are expected to meet or exceed. This is not a guarantee and this graph should be used for estimation purposes only.

BALL SCREW LIFE

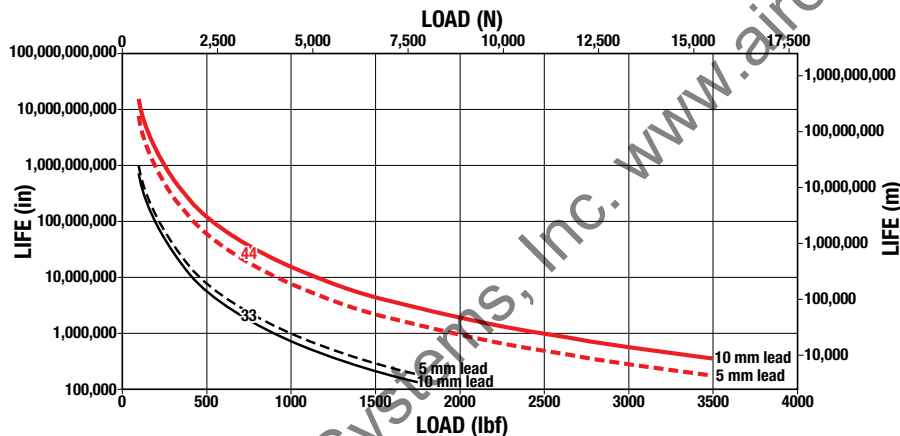

The underlying formula that defines this value is:

$$L_{10} = \left(\frac{C}{F} \right)^3 =$$

Travel life in millions of inches, where:

C = Dynamic load rating (lbf)
F = Cubic mean applied load (lbf)

All curves represent properly lubricated and maintained actuators.

SIDE LOAD CONSIDERATIONS

The IMA integrated motor actuator is not meant to be used in applications where side loading occurs.

Loads must be guided and supported. Loads should be aligned with the line of motion of the thrust rod.

Side loading will affect the life of the actuator.

LUBRICATION: DO NOT FILL WITH GREASE!

IMA actuators have been lubricated at the factory and are ready for installation. For many applications the unit is greased for life.

- For light to moderate use, no additional lubrication is required.
- For severe duty use, periodic re-lubrication will be necessary to maintain optimum performance. Grease should be added every 1,000 hours of operation.
- Re-lubricate with Mobilith SHC220 (IMA33: 3.0 g; IMA44 5.0 g) in the grease zerk provided.

Overfilling will cause a reduction in performance, excessive heat build up and potential premature failure.

QUESTIONS?

Contact Tolomatic for assistance in choosing the correct IMA actuator and options required for your application.



FREE - Windows® compatible software, download at www.tolomatic.com

Or Call 1-800-328-2174 for Excellent Customer Service & Technical Support

IMA - Integrated Motor Actuator

Dimensions: IMA33

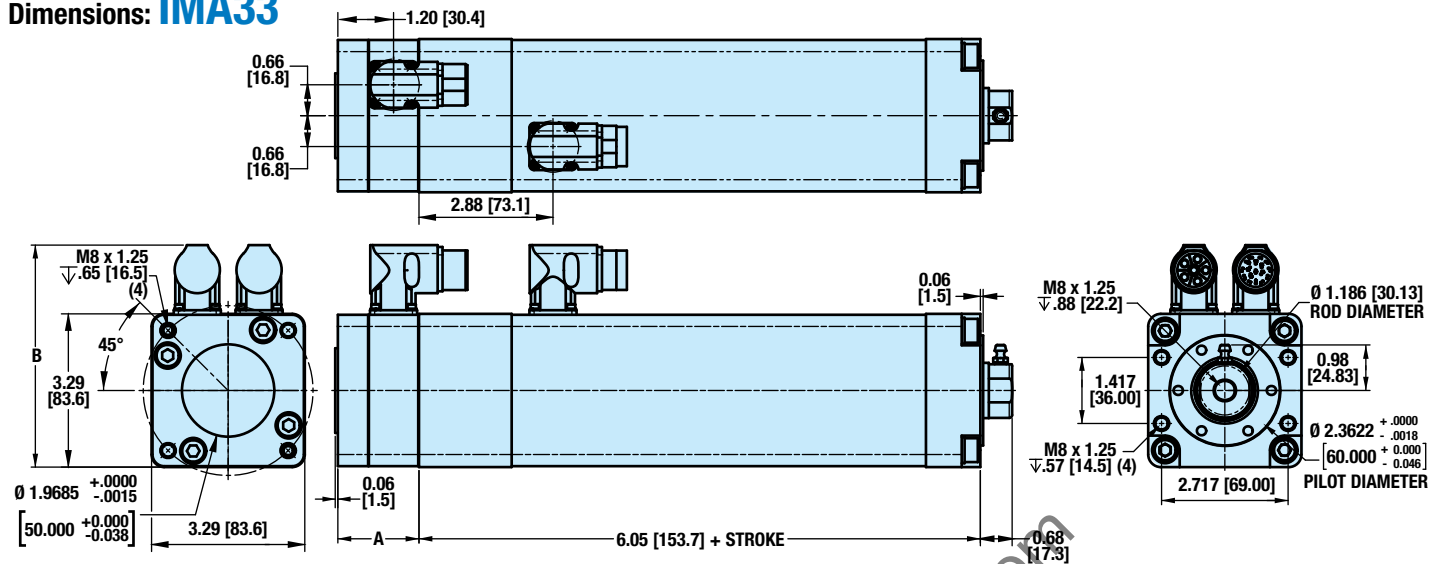

FEEDBACK	DIM "A"	
	in	mm
Digital Encoder	1.74	44.2
Digital Encoder with Brake	3.18	80.8
Digital Encoder (Emerson NT)	1.98	50.3
Digital Encoder with Brake (Emerson NT)	3.68	93.5
Resolver	1.74	44.2
Resolver with Brake	3.18	80.8
Absolute Encoder	TBD*	TBD*
Absolute Encoder w/ Brake	TBD*	TBD*

CONNECTORS	DIM "B"	
	in	mm
Tolomatic Standard		
Bosch MSK Motor Series	4.81	122.2
Emerson FM Series		
Lenze MCS Motor Series		
Emerson NT Series**	4.81	122.2

**Uses Box Mount Connectors (IP67 not available)

*TBD = To Be Determined

EXTERNAL THREADED ROD END (MET)

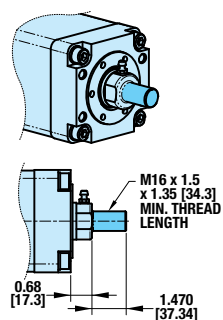

CLEVIS ROD END (RCL)

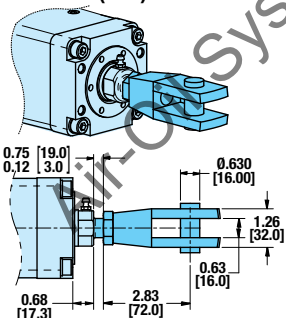

SPHERICAL ROD EYE (SRE)

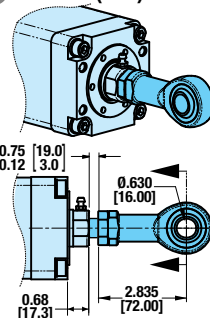

ALIGNMENT COUPLER (ALC + MET)

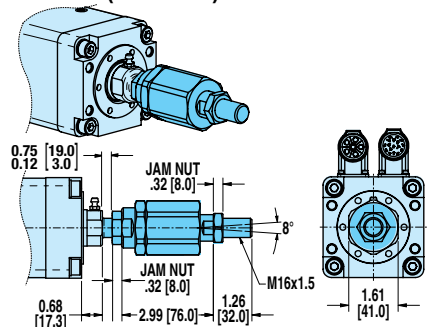

- Go to www.tolomatic.com
- Click on this icon
- Configure stroke length and download
- Place the solid model in your application assembly

IMA - Integrated Motor Actuator

Dimensions: **IMA33**

REAR CLEVIS MOUNT (PCD)

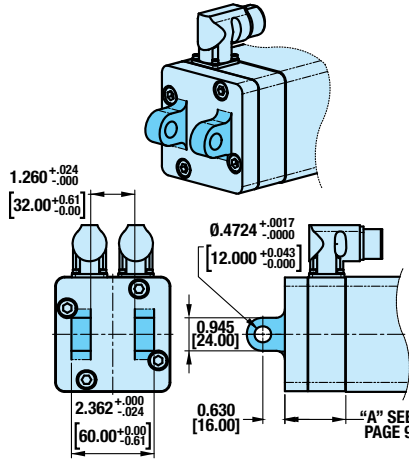

FRONT FLANGE MOUNT (FFG)

May be mounted horizontally (as shown) or vertically

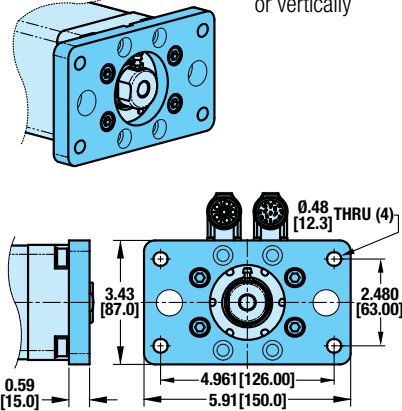

FRONT TRUNNION MOUNT (TRF)

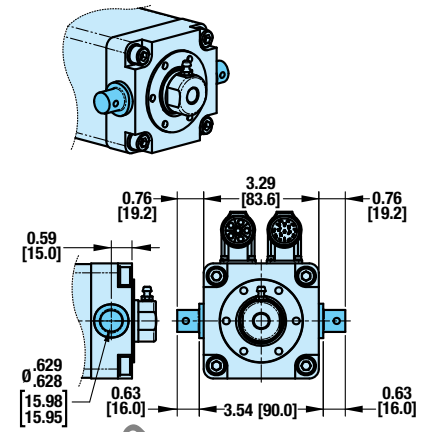

SIDE MOUNTING (MST)

NOTE: THREADED HOLES ON 3 SIDES (2 SIDES AND BOTTOM)

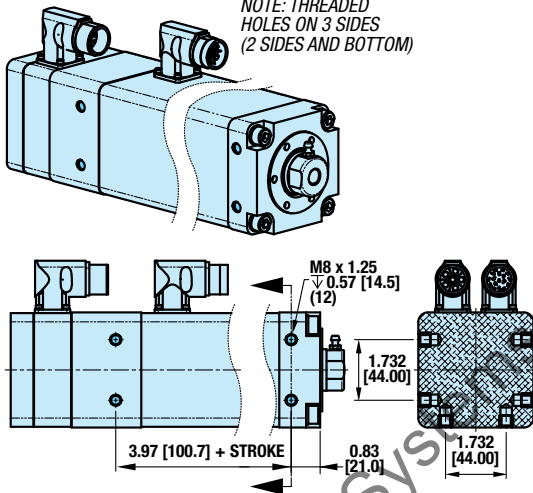

MOUNTING PLATES (MP2)

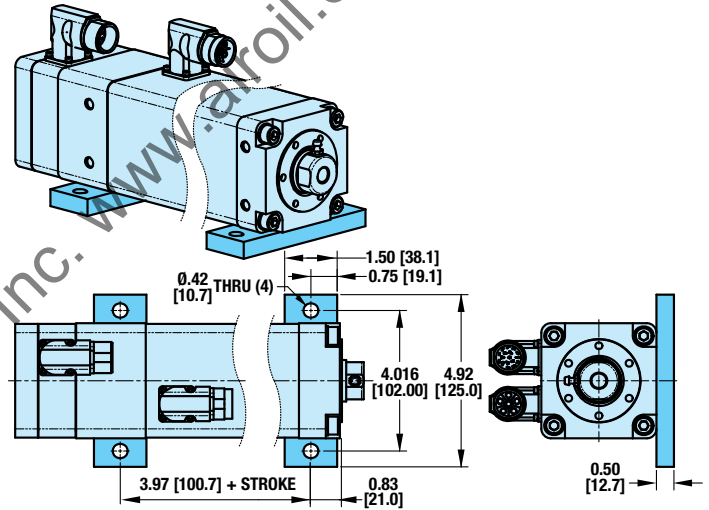

REAR TRUNNION MOUNT (TRR)

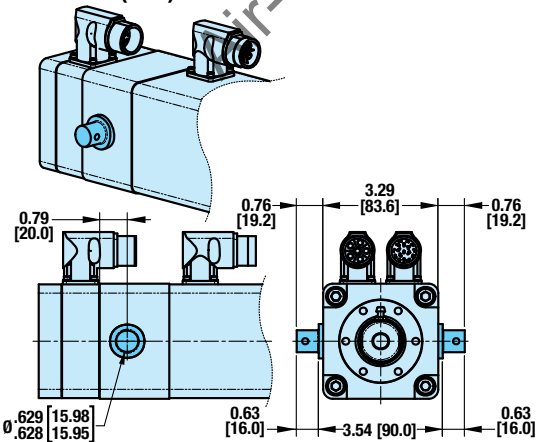

ANTI ROTATE (ARO)

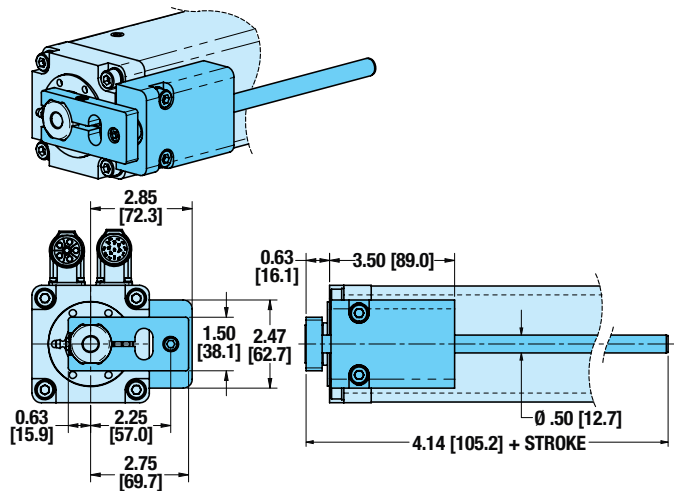

NOTE: When ARO is used together with FFG stroke is reduced by 0.45" [11.4 mm]



IMA - Integrated Motor Actuator

Dimensions: IMA44

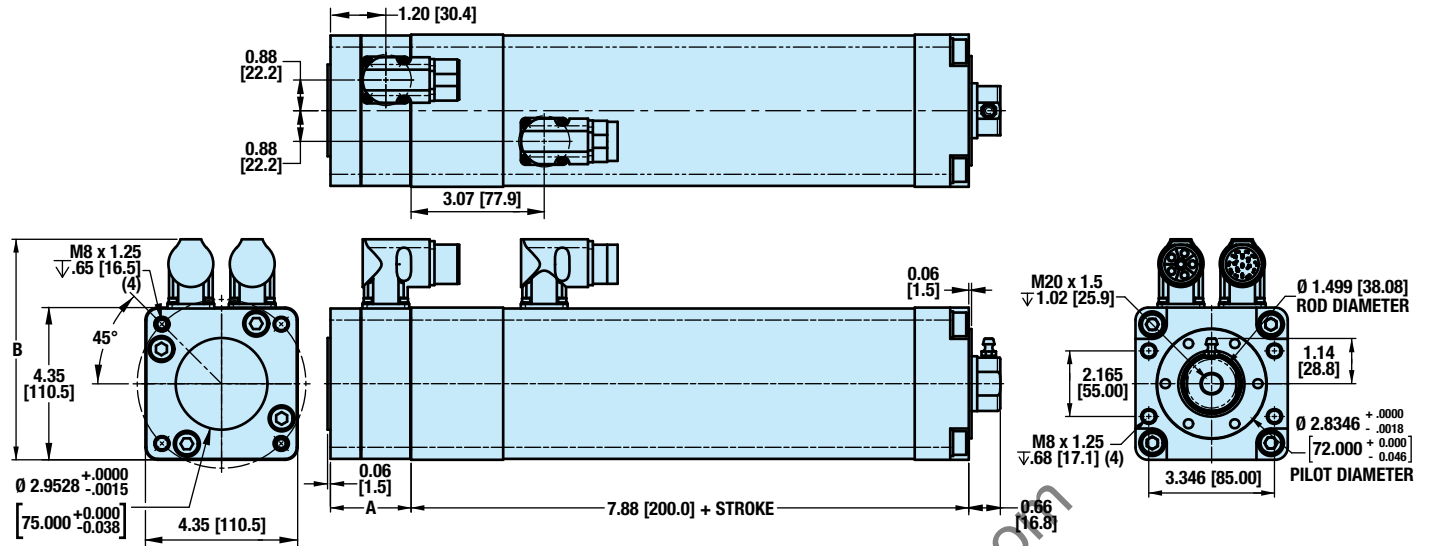

FEEDBACK	DIM "A"	
	in	mm
Digital Encoder	1.74	44.2
Digital Encoder with Brake	3.15	80.0
Digital Encoder (Emerson NT)	1.98	50.3
Digital Encoder with Brake (Emerson NT)	3.50	89.0
Resolver	1.74	44.2
Resolver with Brake	3.15	80.0
Absolute Encoder	TBD	TBD
Absolute Encoder with Brake	TBD	TBD

CONNECTORS	DIM "B"	
	in	mm
Tolomatic Standard		
Emerson FM Series	5.89	149.6
Lenze MCS Motor Series		
Bosch MSK Motor Series	5.89	149.6
Emerson NT Series**	5.50	139.7

**Uses Box Mount Connectors (IP67 not available)

*TBD = To Be Determined

EXTERNAL THREADED ROD END (MET)

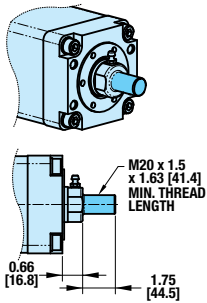

CLEVIS ROD END (RCL)

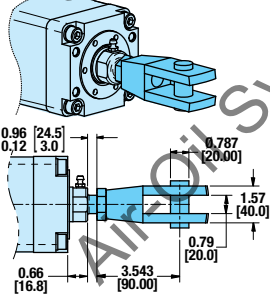

SPHERICAL ROD EYE (SRE)

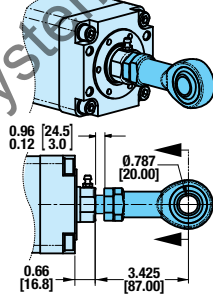

ALIGNMENT COUPLER FEMALE (ALC)

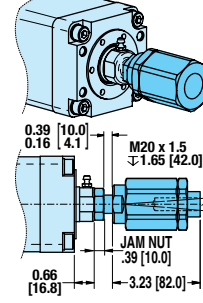

ALIGNMENT COUPLER MALE (ALC + MET)

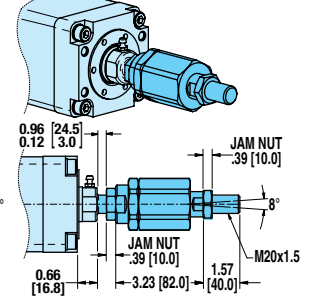

- Go to www.tolomatic.com
- Click on this icon
- Configure stroke length and download
- Place the solid model in your application assembly

IMA - Integrated Motor Actuator

Dimensions: **IMA44**

REAR CLEVIS MOUNT (PCD)

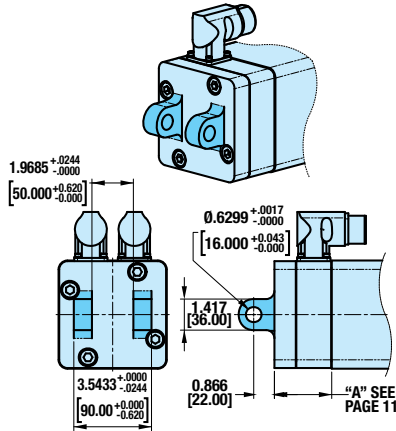

FRONT FLANGE MOUNT (FFG)

May be mounted horizontally (as shown) or vertically

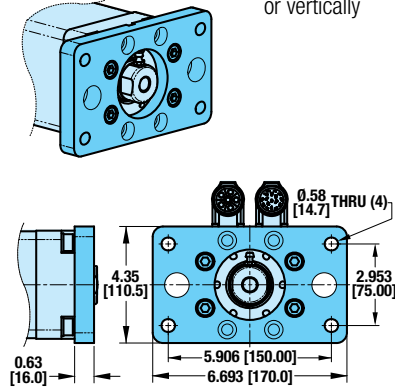

FRONT TRUNNION MOUNT (TRF)

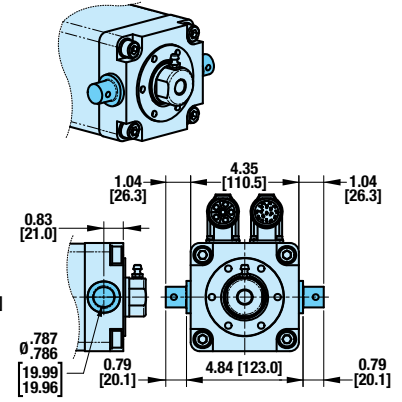

SIDE MOUNTING (MST)

NOTE: THREADED HOLES ON 3 SIDES (2 SIDES AND BOTTOM)

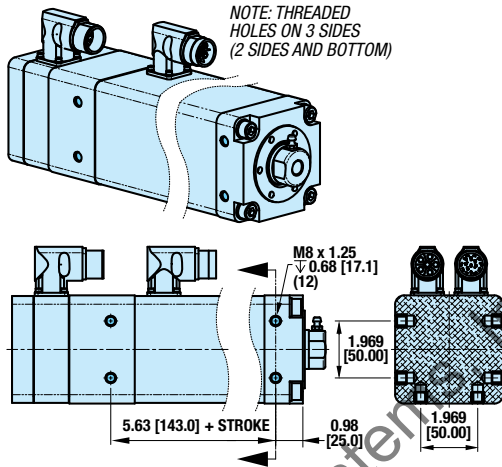

MOUNTING PLATES (MP2)

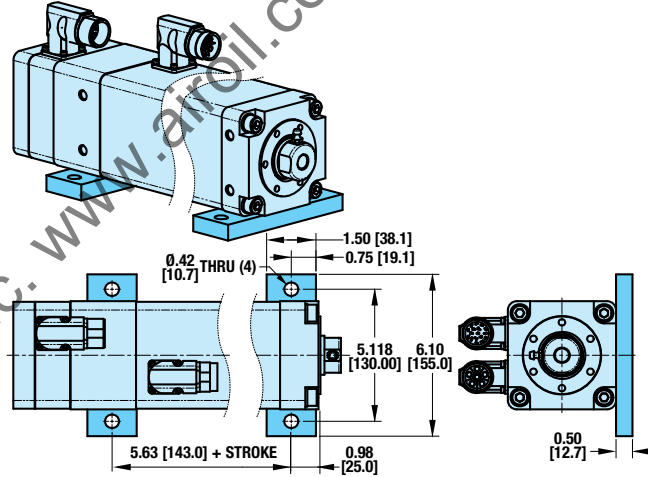

REAR TRUNNION MOUNT (TRR)

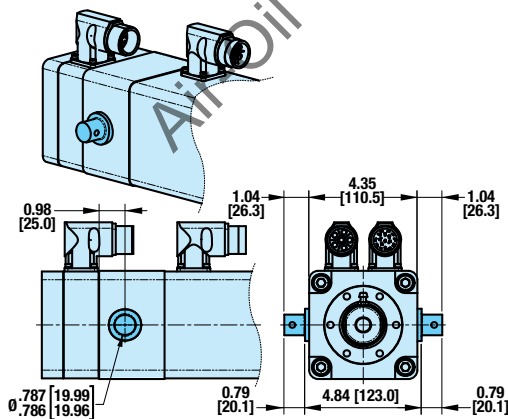

ANTI ROTATE (ARO)

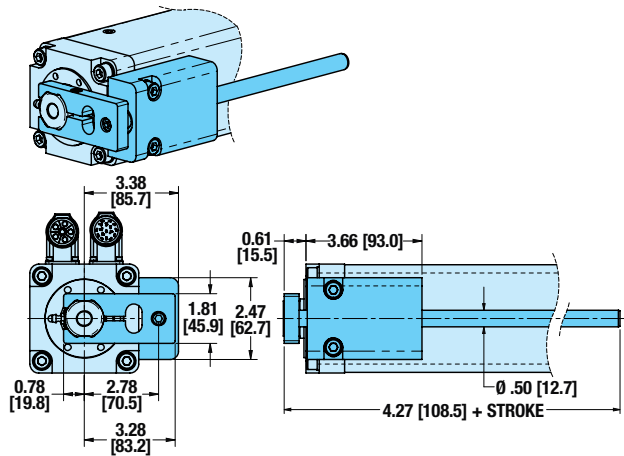

NOTE: When ARO is used together with FFG stroke is reduced by 0.51" [13.0 mm]



APPLICATION DATA WORKSHEET Fill in known data. Not all information is required for all applications

ORIENTATION

Horizontal Vertical Incline ° α

SIZING SOFTWARE

FREE - Windows® compatible software, download at www.tolomatic.com

Or Call 1-800-328-2174 for Excellent Customer Service & Technical Support

Load supported by actuator OR Load supported by other mechanism

MOVE PROFILE

EXTEND

Move Distance _____
 inch millimeters

Move Time _____ sec

Max. Speed _____
 in/sec mm/sec

Dwell Time After Move _____ sec

RETRACT

Move Distance _____
 inch millimeters

Move Time _____ sec

Max. Speed _____
 in/sec mm/sec

Dwell Time After Move _____ sec

STROKE LENGTH

inch (S/K) (U.S. Standard) millimeters (S/M) (Metric)

NOTE: If load or force changes during cycle use the highest numbers for calculations

EXTEND	RETRACT
LOAD	LOAD
<input type="checkbox"/> lb. (U.S. Standard) <input type="checkbox"/> kg. (Metric)	<input type="checkbox"/> lb. (U.S. Standard) <input type="checkbox"/> kg. (Metric)
FORCE	FORCE
<input type="checkbox"/> lb. (U.S. Standard) <input type="checkbox"/> kg. (Metric)	<input type="checkbox"/> lb. (U.S. Standard) <input type="checkbox"/> kg. (Metric)

PRECISION

Repeatability _____
 inch millimeters

OPERATING ENVIRONMENT

Temperature, Contamination, etc.

NO. OF CYCLES

per minute per hour

HOLD POSITION?

Required Not Required
 After Move During Power Loss

MOTION PROFILE

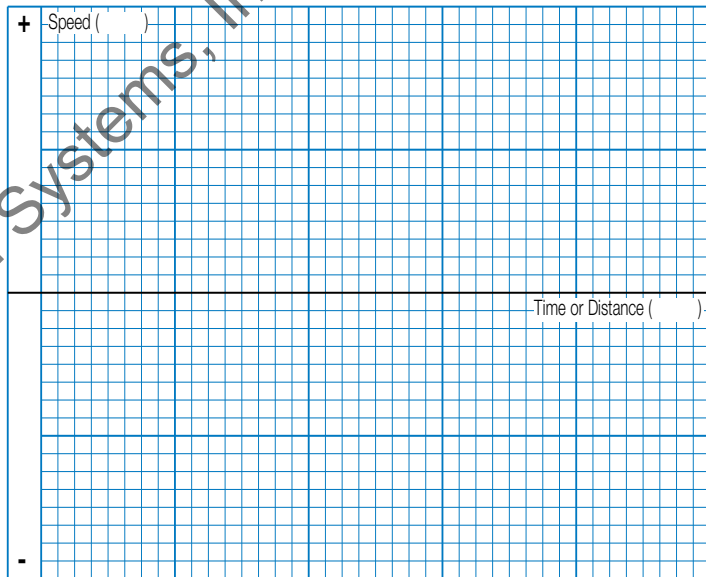

Graph your most demanding cycle, including accel/decel, velocity and dwell times. You may also want to indicate load variations and I/O changes during the cycle. Label axes with proper scale and units.

CONTACT INFORMATION

Name, Phone, Email _____

Co. Name, Etc. _____

STOP USE THE TOLOMATIC SIZING AND SELECTION SOFTWARE AVAILABLE ON-LINE AT www.tolomatic.com OR... CALL TOLOMATIC AT 1-800-328-2174. We will provide any assistance needed to determine the proper actuator for the job.

FAX 1-763-478-8080

EMAIL help@tolomatic.com

IMA - Integrated Motor Actuator

Selection Guidelines

1 ESTABLISH MOTION PROFILE

Using the application stroke length, desired cycle time and loads establish the motion profile details.

the actuator's body can approach 180°F (82°C) in aggressive applications. Adequate clearance to ensure actuator's ambient conditions do not rise drastically should be allowed.

2 COMPARE PEAK THRUST AND SPEED TO PEAK CAPACITIES

Calculate the application required peak thrust and speed and compare to graphs on page 7. (repeated below) Select an actuator that achieves the necessary peak thrust and speed.

SPEED vs THRUST IMA33

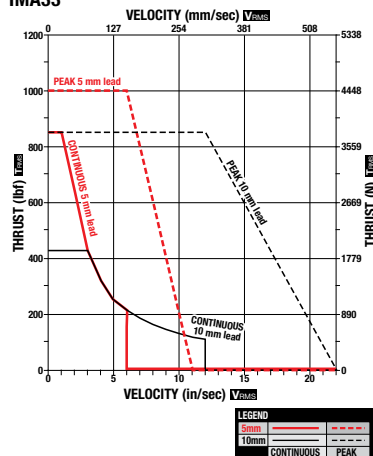

IMA44

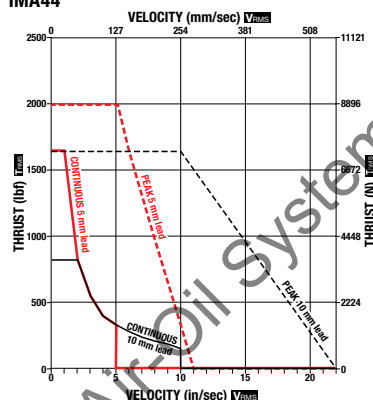

3 COMPARE CONTINUOUS THRUST AND SPEED TO CONTINUOUS CAPACITIES

Calculate the Continuous or RMS thrust and speed required and compare to graphs on page 7. (repeated above) Select an actuator that achieves the necessary thrust and speed for continuous operation. See complete instructions on page 7 for help calculating continuous force.

$$T_{RMS} = \sqrt{\frac{\sum (T_i^2 \times t_i)}{\sum (t_i)}} \quad v_{RMS} = \sqrt{\frac{\sum (V_i^2 \times t_i)}{\sum (t_i)}}$$

4 TEMPERATURE

The IMA is intended to operate in an environment with an ambient temperature between 50-122° F, (10-50° C). Performance should be de-rated if the ambient temperature is above 77° F (25° C). Contact the factory if the ambient temperature does not fit within this range. NOTE: Temperature of

5 BRAKE CONSIDERATIONS

An unpowered IMA will require a brake to maintain its position if the force on the actuator exceeds Back Drive Force listed in the table on page 6.

A brake can be used with the actuator to keep it from back-driving, typically in vertical applications. A brake may be used for safety reasons or for energy savings allowing the actuator to hold position when unpowered. See page 15 for ordering information.

NOTE: The optional Spring-Applied/Electronically-Released Brake requires 24V power. Input current rating: IMA33 - 0.516 Amps; IMA44 - 0.67 Amps.

6 CHOOSE MOTOR CONNECTORS & FEEDBACK DEVICE

Connector choice and wiring emulates popular motor manufacturers for compatibility.

Current connector choices include:

- Bosch Rexroth MSK Series
- Emerson FM & NT Series
- Lenze MCA Series

Current feedback choices include:

- Digital Encoder
- Absolute Encoder
- Resolver

Contact Tolomatic for additional motor connectors and feedback combinations

7 CONSIDER MOUNTING & ROD END OPTIONS

Examine mounting options dimensional drawings on page 9 to 12. Standard mounting on the IMA are 4 tapped holes on the front rod end face of the actuator. The Side Mount option (MST) includes 12 tapped holes, 4 on each side and 4 on the bottom of the actuator. Other fixed mounting options are the Front Flange Mount (FFG) and Mounting Plates (MP2). Pivoting mount options are Front Trunnion (TRF), Rear Trunnion (TRR) and Rear Clevis Mount (PCD).

Rod End Options include: External Threaded Rod End (MET), Clevis Rod End (RCL), Spherical Rod Eye (SRE) and Alignment Coupler (ALC).

NOTE: Regardless of the mounting option chosen, care must be taken to ensure that the load is guided and in-line with the thrust rod's line of motion. Misalignment of the thrust rod's line of motion will cause degradation in the actuator's expected life.

8 CONSIDER ENVIRONMENTAL RATING AND ANTI-ROTATE OPTIONS

The environmental rating for a standard IMA is IP65, choose IP67 for protection against water and dust ingress. Choose the Anti-Rotate Option (ARO) if required. Call Tolomatic at 1-800-328-2174 for help in determining the best actuator for your application.

IMA - Integrated Motor Actuator

Ordering

MODEL SELECTION (MUST BE IN THIS ORDER)

OPTIONS (IN ANY ORDER)

IMA **44** **BN05** **SM304-8** **MV23** **DT1D1N** **ALC** **MP2** **IP67** **CR6**

MODEL
IMA Integrated Motor Actuator

SIZE
33 33 Series Actuator
44 44 Series Actuator

NUT / SCREW
BN05 Ball Nut, 5 mm lead
BN10 Ball Nut, 10 mm lead

STROKE LENGTH
SM Stroke, (152.4 to 457.2) enter stroke length in millimeters

MOTOR VOLTAGE
MV23 230 Vac, Motor Voltage, 3 Stack Winding
MV43 460 Vac, Motor Voltage, 3 Stack Winding

! Not all codes listed are compatible with all options.

VISIT www.tolomatic.com FOR COMPLETE, UP-TO-DATE INFORMATION

MOTOR CONNECTORS / ENCODER / BRAKE	
DT1 D1B	Tolomatic Standard Motor, Digital Quadrature 2000 Line Encoder, Brake
DT1 D1N	Tolomatic Standard Motor, Digital Quadrature 2000 Line Encoder, NO Brake
DT1 R1B	Tolomatic Standard Motor, Resolver, BRX, Brake
DT1 R1N	Tolomatic Standard Motor, Resolver, BRX, NO Brake
DT1 A1B	Tolomatic Standard Motor, Stegmann Hiperface® Multi-turn ABS MT, Brake
DT1 A1N	Tolomatic Standard Motor, Stegmann Hiperface® Multi-turn ABS MT, NO Brake
DB1 A1B	Bosch Rexroth MSK Motor, Stegmann Hiperface® Multi-turn ABS MT, Brake
DB1 A1N	Bosch Rexroth MSK Motor, Stegmann Hiperface® Multi-turn ABS MT, NO Brake
DE1 D1B	Emerson FM Motor series, Digital Quadrature 2000 Line Encoder, Brake
DE1 D1N	Emerson FM Motor series, Digital Quadrature 2000 Line Encoder, NO Brake
DE1 R1B	Emerson FM Motor series, Resolver, BRX, Brake
DE1 R1N	Emerson FM Motor series, Resolver, BRX, NO Brake
DE1 A1B	Emerson FM Motor series, Stegmann Hiperface® Multi-turn ABS MT, Brake
DE1 A1N	Emerson FM Motor series, Stegmann Hiperface® Multi-turn ABS MT, NO Brake
DE2*D1B	Emerson NT Motor series, Digital Quadrature 2000 Line Encoder, Brake
DE2*D1N	Emerson NT Motor series, Digital Quadrature 2000 Line Encoder, NO Brake
DL1 D1B	Lenze MCS Motor series, Digital Quadrature 2000 Line Encoder, NO Brake
DL1 D1N	Lenze MCS Motor series, Digital Quadrature 2000 Line Encoder, Brake
DL1 R1B	Lenze MCS Motor series, Resolver BRX, Brake
DL1 R1N	Lenze MCS Motor series, Resolver BRX, NO Brake
DL1 A1B	Lenze MCS Motor series, Stegmann Hiperface® Multi-turn ABS, Brake
DL1 A1N	Lenze MCS Motor series, Stegmann Hiperface® Multi-turn ABS, NO Brake

Contact Tolomatic for additional motor connectors & feedback combinations

*NOTE: IP67 is not available with DE2 (Emerson NT connectors)

ROD END OPTIONS
— Standard, female, internally threaded rod end
MET Male Externally Threaded Rod End
SRE Spherical Eye Rod End
RCL Clevis Rod End
ALC Alignment Coupler

MOUNTING OPTIONS
Standard Face Mount
MP2 Mounting Plates - 2 req.
FFG Front Flange Mount
TRF Trunnion Mount, Front
TRR Trunnion Mount, Rear
PCD Clevis Mount, Rear
MST Side Mount (tapped holes on 3 sides)

OTHER OPTIONS
IP67 Ingress Protection Rating
ARO Anti Rotate

CABLES
Tolomatic standard 6m flying lead cables, power and feedback. For custom cable lengths please contact Tolomatic. Lead times will vary. *NOTE: use cables from drive manufacturer for all others*
CR6

Call Tolomatic 1-800-328-2174 to determine available options and accessories based on your application requirements.

Replacement Option Parts Ordering

PART NO.	DESCRIPTION
2733-9014	Spherical Rod Eye Kit, IMA33
2744-9014	Spherical Rod Eye Kit, IMA44
2733-9015	Clevis Rod End Kit, IMA33
2744-9015	Clevis Rod End Kit, IMA44
2132-1060	Alignment Coupler Kit, IMA33
2150-1060	Alignment Coupler Kit, IMA44
2733-9010	Mounting Plate Kit, IMA33
2744-9010	Mounting Plate Kit, IMA44
2733-9018	Front Flange Mount Kit, IMA33
2744-9018	Front Flange Mount Kit, IMA44
2733-1045	Rear Clevis Mount, IMA33
2744-1045	Rear Clevis Mount, IMA44
2733-9075	Anti Rotate, Bearing Assy, IMA33 & IMA 44

PART NO.	DESCRIPTION
2733-9074	Anti Rotate, Shaft Clamp, IMA33
2733-1211	Anti Rotate, Shaft, IMA33 - Indicate Stroke
2744-9074	Anti Rotate, Shaft Clamp, IMA44
2744-1211	Anti Rotate, Shaft, IMA44 - Indicate Stroke
2733-1221	Motor Power Cable, IMA33 NO Brake
2733-1222	Motor Power Cable, IMA33 with Brake
2744-1221	Motor Power Cable, IMA44 NO Brake
2744-1222	Motor Power Cable, IMA44 with Brake
2733-1223	Feedback Cable, 12 pin (Resolver & Stegmann)
2733-1224	Feedback Cable, 17 pin (Digital Encoder)

All parts are listed for REPLACEMENT ONLY. If not ordered on original unit the IMA may require additional tapped holes or replacement rod end. Contact Tolomatic.

THE TOLOMATIC DIFFERENCE What you expect from the industry leader:



EXCELLENT CUSTOMER SERVICE & TECHNICAL SUPPORT

Our people make the difference! Expect prompt, courteous replies to all of your application and product questions.



INDUSTRY LEADING DELIVERIES

Standard catalog products are built to order and ready-to-ship in 5 days or less. Modified and custom products ship weeks ahead of the competition.

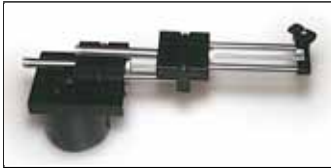

INNOVATIVE PRODUCTS

From standard catalog products... to modified products... to completely unique custom products, Tolomatic designs and builds the best solutions for your challenging applications.



SIZING & SELECTION SOFTWARE

Windows® compatible, downloadable from our website – FREE – the best tool of its kind on the market! Product selection has never been easier.



3D MODELS & 2D DRAWINGS AVAILABLE ON THE WEB

Easy to access CAD files are available in many popular formats.

ALSO CONSIDER THESE OTHER TOLOMATIC PRODUCTS:

PNEUMATIC PRODUCTS



RODLESS CYLINDERS: *Band Cylinders, Cable Cylinders, MAGNETICALLY COUPLED CYLINDERS/SLIDES; GUIDED ROD CYLINDER SLIDES; ROTARY ACTUATORS*
 "FOLDOUT" BROCHURE #9900-9075 PRODUCTS BROCHURE #9900-4028 www.tolomatic.com/pneumatic

ELECTRIC PRODUCTS



ROD & GUIDED ROD STYLE ACTUATORS, HIGH THRUST ACTUATORS, SCREW & BELT DRIVE RODLESS ACTUATORS, MOTORS, AXIOM DRIVES/CONTROLLERS
 "FOLDOUT" BROCHURE #9900-9074 PRODUCTS BROCHURE #9900-4016 www.tolomatic.com/electric

POWER TRANSMISSION PRODUCTS



GEARBOXES: *Float-A-Shaft®, Slide-Rite®, DISC CONE CLUTCH; CALIPER DISC BRAKE*
 "FOLDOUT" BROCHURE #9900-9076 PRODUCTS BROCHURE #9900-4029 www.tolomatic.com/pt



3800 County Road 116 • Hamel, MN 55340 U.S.A.
 Phone: (763) 478-8000 • Fax: (763) 478-8080

Toll-Free: **1-800-328-2174**

Email: help@tolomatic.com • <http://www.tolomatic.com>

All brand and product names are trademarks or registered trademarks of their respective owners. Information in this document is believed accurate at time of printing. However, Tolomatic assumes no responsibility for its use or for any errors that may appear in this document. Tolomatic reserves the right to change the design or operation of the equipment described herein and any associated motion products without notice. Information in this document is subject to change without notice.

Visit www.tolomatic.com for the most up-to-date technical information

