

ISO SERIES

THE PATENTED SPOOL AND SLEEVE ASSEMBLY THE HEART OF EVERY NUMATICS AIR VALVE

The Numatics famous lapped spool and floating sleeve assembly is a matched set, machined from stainless steel to millionths of an inch precision. Its patented*, balanced construction relies on an air bearing principle, eliminating always troublesome dynamic o-ring seals. The sleeve remains stationary in the valve housing, "floating" on six static seals. The sliding spool is "sealed" simply by virtue of the close finish tolerances.

With the spool floating on a film of air molecules, there is no metal-to-metal contact. Heat treating of the spools and sleeves gives a hardness necessary to combat pipe scale and other air line contaminants. The spool is "balanced" with respect to air pressure, and

offers extreme versatility of valve application. It supplies true multipurpose construction. The floating sleeve insures freedom from any mechanical distortion imposed on the valve body. Lubricated or properly filtered dry air will insure longer life; however, the spool and sleeve's unique design, and its inherent resistance to contaminants and sticking, will provide years and years of troublefree service, exceeding industrial standards of design and performance.

All these factors give the Numatics spool and sleeve a reliability and long service life which have been field proven in maintenance-free operation, typically outlasting the life of the machine on which it was installed. Its rugged versatility is unmatched. It has been envied and maligned, copied and imitatedbut never duplicated.

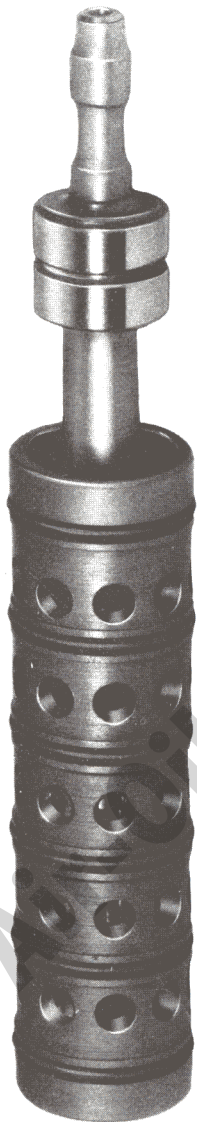

FEATURE

**No Dynamic
Rubber Packings**

**Balanced
Spool Design**

Longest Service Life

**Floating Spool and
Sleeve Construction**

ADVANTAGE

Both spool and sleeve are stainless steel, precision machined to close tolerances. They are a matched set and spools are not interchangeable.

Air enters the sleeve, and the matched fit allows minute leakage across the spool. This centers the spool in the sleeve and acts as an air bearing. There is no metal-to-metal contact.

Sealing is accomplished by the closely maintained fit between the spool and sleeve.

Air bearing principle allows all valves to operate dry without any lubrication.

Vacuum to 300 PSIG independent of pilot pressure. Full back pressure at any port does not affect operation. There is no blow-by to exhaust during spool shift.

Consistent valving action independent of pressure or vacuum.

Constant shifting forces thus making direct solenoid operation possible.

Provides multipurpose valve versatility.

Razor sharp edges on the spool are a perfect shear against the holes in the sleeve to fight air line contaminants.

2 micro inch surface finish on O.D. (outside diameter) of spool and I.D. (inside diameter) of sleeve make it difficult for air line contaminants to adhere.

Static o-ring seals float the sleeve in the body, eliminating binding caused by temperature changes or uneven torquing of mounting bolts and pipe fittings.

VALVE FEATURES AND CONSTRUCTION

NUMATICS® ISO SERIES

Numatics ISO Series valves are high speed, heavy duty valves, designed for general service on all types of automation. All valves comply with ISO standard 5599/1 for valve unit to base interchangeability. They are true multi-purpose valves and employ the patented spool and sleeve assembly described on page 2. They are completely balanced which means any port may be pressurized without affecting valve operation.

All direct solenoid actuated and air pilot actuated valves may be used as normally open or closed 2- or 3-way valves, single or dual pressure 4-ways, or as selector or diverter valves, dependent only on how they are piped plugged.

All solenoid-pilot actuated valves are shipped with internal pilot supply from port No. 1. These can be used as a single pressure 4-way, or 2-way or 3-way, normally open or normally closed. By converting to external pilot, it can be used as a dual pressure 4-way, pressure selector, or pressure diverter. To specify external pilot supply, add "14X" to the model number. See Page 14.

In addition to the multi-purpose feature all ISO valves offer, Numatics makes each size available with four different valve functions and three different methods of actuation.

VALVE FUNCTIONS

Single Solenoid (Pilot), Spring Return. These valves are actuated by a maintained signal. When the signal is removed, the spring returns the spool to the normal position.

Double Solenoid (Pilot), 2-position, detented. These valves are actuated by either a momentary or a maintained signal, applied alternately. When the signal is removed, the spool remains in the shifted position until the alternate signal is applied. The detent assembly prevents inadvertent spool shift due to machine vibration, shock, or signal failure.

Double Solenoid (Pilot) 3-position, spring centered. 3-position valves are multi-purpose 4-way valves with a third center position. Valve actuation is produced by applying a maintained signal alternately. When both signals are removed, the spring's center the spool and provide the third position. Refer to the model selection chart on page 5.

VALVE ACTUATION

DIRECT SOLENOID ACTUATED

Direct solenoid actuated valves offer the simplest valve construction on the market today. There are only two moving parts because the solenoid plunger acts directly in the spool to shift it. When using double solenoid

actuated valves, electrical interlocks should be provided to prevent energizing both solenoids simultaneously.

SOLENOID-PILOT ACTUATED

Solenoid-piloted valves provide a smaller solenoid that actuates a pilot plunger. Energizing the solenoid lifts the plunger and allows pilot air to shift the main spool. When the solenoid is de-energized, pilot air is exhausted. This type of actuation offers the advantage of lower power consumption and in the event of double energization, electrical interlocks are not required to prevent solenoid burnout.

AIR-PILOT ACTUATED

Air piloted valves are actuated directly by applying an air signal directly to the pilot ports provided in the mounting. The pilot pressure requirements are given on page 4.

MOUNTINGS

ISO Series valves are sub-base mounted valves that may be mounted in any position. They are available with individual base mountings or manifold block mountings that may be joined in any number of stations up to a recommended maximum of twelve stations. Refer to the model selection chart on Page 5 for specific mountings.

SOLENOID CONNECTION: All ISO Series valves have a plug-in, grounded solenoid that accepts plugs complying with Din Spec. No. 43650. These are available in grey, black or translucent with built-in indicator light. Cable diameter .310 to .410 inches.

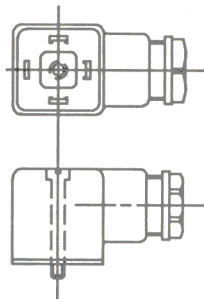

PART NO.

230-369A
230-370A
230-371A
230-372A
230-373A

DESCRIPTION

Grey (14) Plug Assy.
Black (12) Plug Assy.
Plug with 24VDC Light
Plug with 110VAC Light
Plug with 220VAC Light

CONSTRUCTION MATERIALS

- Body, mountings, end caps, override assemblies:
These parts are either die cast or sand cast aluminum alloy, anodized for protection from corrosion. In addition, all parts except mountings are painted.
- Spool and Sleeve: Stainless Steel
- Seals and Gaskets: Oil Resistant Rubber
- Other Parts: Stainless Steel, Aluminum alloy, or inert plastic.

numatics®

ISO SERIES

OPERATING DATA

SOLENOIDS: All solenoids are continuous duty rated for dual Hz. operation. Standard voltages are as follows:

DIRECT SOLENOID: 100-115/50; 110-120/60 or 200-230/50; 220-240/60. 24 VDC is standard for ISO 1

and ISO 2. D.C. is not available for ISO 3 direct acting. SOLENOID-PILOT: 24/50-50, 100-115/50; 110-120/60, or 200-230/50; 220-240/60. 24 VDC is standard for all series.

DIRECT SOLENOID ACTUATED		SINGLE SOLENOID			DOUBLE SOLENOID		
		ISO 1	ISO 2	ISO 3	ISO 1	ISO 2	ISO 3
INRUSH CURRENT (AMPS.)	24/60	2.50	2.50	12.9	2.50	2.50	12.4
	120/60	.50	.50	2.5	.50	.50	2.1
	230/60	.26	.26	1.3	.26	.26	1.0
	24 VDC	.25	.25	N/A	.25	.25	N/A
HOLDING CURRENT (AMPS.)	24/60	.40	.40	1.8	.40	.40	1.2
	120/60	.08	.08	.28	.08	.08	.24
	230/60	.04	.04	.15	.04	.04	.10
	24 VDC	.25	.25	N/A	.25	.25	N/A
TIME TO ENERGIZE (SEC.) A.C./D.C.		.012/.038	.012/.038	.015 A.C.	.012/.012	.012/.012	.018 A.C.
TIME TO DE-ENERGIZE (SEC.) A.C./D.C. (SINGLE SOLENOID AND 3-POSITION)		.012/.012	.012/.012	.030 A.C.	.012/.012	.012/.012	.030 A.C.

SOLENOID-PILOT ACTUATED	24/60	120/60	230/60	24 VDC
INRUSH CURRENT (AMPS.)	1.00	.19	.11	---
HOLDING CURRENT (AMPS.)	.73	.14	.08	.31
D.C. WATTS, INRUSH AND HOLDING, ALL VOLTAGES (MAX.)	---	---	---	7.5*
TIME TO ENERGIZE AT 80 PSIG (SEC.)	.015	.015	.015	.020
TIME TO DE-ENERGIZE AT 80 PSIG (SEC.) (SINGLE SOLENOID-PILOT AND 3- POSITION)	.036	.036	.036	.032

* A 4.0 watt D.C. solenoid is available on special order. Add "017G" to the model number.

Pressure Range:

Direct Solenoid: 28" Hg. Vacuum to 16 BAR (232 PSIG)

Solenoid-Pilot:

Internal Pilot: 1-16 BAR (14.5 to 232 PSIG)

External Pilot:

Main Valve: 28" Hg vacuum to 16 BAR (232 PSIG)

Pilot Supply: 1-16 BAR (14.5 to 232 PSIG)

Air-Pilot:

Main Valve: 28" Hg Vacuum to 16 BAR (232 PSIG)

Pilot Supply: 1-16 BAR (14.5 to 232 PSIG)

Temperature Range: -23.3° C to + 46.1° C Ambient

(-10° F to + 115° F)

Service: Valves can be used on the following properly filtered media:

Lubricated air, dry (oil free) air, vacuum, and non-corrosive, non-toxic, non-flammable dry gases. See Numatics Engineering and Technical Data for a list of recommended lubricants and filtration requirements for unlubricated service.

Flow Capacity: ISO Series valve have a Cv as listed below. See Numatics Engineering and Technical Data for complete flow chart.

ISO 1: Cv=1.2
 ISO 2: Cv=1.7
 ISO 3: Cv=4.4

HOW TO ORDER AND MODEL SELECTION CHART

HOW TO ORDER

Order any standard ISO valve from the model selection chart below. Be certain to check your model selection with the port size and types available.

All solenoid-pilot actuated valves are furnished with

internal pilot supply from port number 1. If external pilot supply is required, add "014X" to the model number. See page 14 for complete details. For pressure regulators, refer to page 10.

MODEL SELECTION CHART

SERIES IDENTIFIER & TAP SIZE	"14" ACTUATOR	"12" ACTUATOR	FUNCTION	MOUNTING	WIRING OPTION	TAP TYPE
* I12 = ISO 1 1/4" I13 = ISO 1 3/8" * I22 = ISO 2 1/4" I23 = ISO 2 3/8" * I34 = ISO 3 1/2" S = Direct Solenoid B = Solenoid Pilot P = Air Pilot J = Air Pilot with Flush Non-Locking Override	S = Direct Solenoid B = Solenoid Pilot P = Air Pilot J = Air Pilot with Flush Non-Locking Override	S = Direct Solenoid B = Solenoid Pilot P = Air Pilot J = Air Pilot with Flush Non-Locking Override A = Spring Return W = Differential Air Return For Solenoid Pilot Only	4 = 2-Position, 4-Way 5 = 3-Position, 4-Way 6 = 3-Position, 4-Way		0 = Air Piloted Valves **2 = Standard A.C. Volts + Hertz **4 = Standard D.C. Volts	* O = Valve Unit Only N = NPTF G = G
* Use these numbers for valve units only. (Mtg. "00") ** NOTE: Order Plug-In Socket Assembly Separately.	230-369A Grey (14 Sol.) 230-370A Black (12 Sol.) 230-371A w/24 Volt Light 230-372A w/110 Volt Light 230-373A w/220 Volt Light		* 00 = Valve Unit Only 15 = Manifold Block, Side & Bottom Cylinder Ports 25 = Block No. 15 with Speed Control 41 = Side Port Base, Individual Exhaust 46 = Base No. 41 with Speed Control 56 = Bottom Port Base, Individual Exhaust 58 = Base No. 56 with Speed Control NOTE: The Following Manifolds Comply With VDMA Specifications. 11 = Manifold Block, Side Ports, Form C + E 21 = Block No. 11 With Speed Control 1A = Manifold Block, Bottom Ports, Form C 1C = Block No. 1A with Speed Control			

IMPORTANT: Check your model number selection with the port sizes and types available.

SERIES	SIDE PORT BASE	BOTTOM PORT BASE	SIDE & BOTTOM PORT MANIFOLD	BOTTOM PORT MANIFOLD (VDMA)
ISO 1	G 1/4" 1/4 NPTF 3/8 NPTF	G 1/4"	1/4 NPTF G 1/4"	1/4 NPTF G 1/4"
ISO 2	G 3/8" 1/4 NPTF 3/8 NPTF	G 3/8"	3/8 NPTF G 3/8"	3/8 NPTF G 3/8"
ISO 3	G 1/2" 1/2 NPTF	G 1/2" 1/2 NPTF	1/2 NPTF G 1/2"	1/2 NPTF G 1/2"

ISO SYMBOLS

DIRECT SOLENOID ACTUATED		SOLENOID PILOT ACTUATED		AIR PILOT ACTUATED	
14	I12, I22, I34 SA4 	12	I12, I22, I34 BA4 	12	I12, I22, I34 JA4
14	I12, I22, I34, SS4 	12	I12, I22, I34, BB4 	12	I12, I22, I34, JJ4
14	I12, I22, I34, SS5 	12	I12, I22, I34, BB5 	12	I12, I22, I34, JJ5
14	I12, I22, I34, SS6 	12	I12, I22, I34, BB6 	12	I12, I22, I34, JJ6

DIRECT SOLENOID ACTUATED

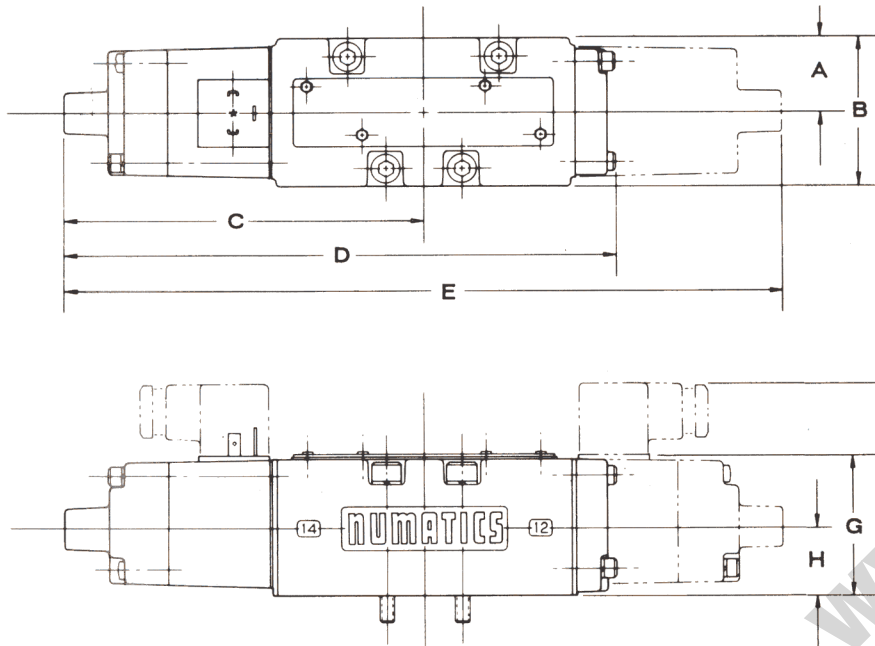

	ISO 1	ISO 2	ISO 3
A	20.8 (.82)	24.9 (.98)	31.8 (1.25)
B	41.9 (1.65)	50.0 (1.97)	63.5 (2.50)
C	120.1 (4.73)	122.4 (4.82)	151.9 (5.98)
D	178.3 (7.02)	183.4 (7.22)	232.9 (9.17)
E	240.3 (9.46)	244.8 (9.64)	303.5 (11.95)
F	74.4 (2.93)	74.9 (2.95)	87.4 (3.44)
G	46.5 (1.83)	47.0 (1.85)	59.4 (2.34)
H	22.4 (.88)	22.9 (.90)	28.4 (1.12)

SOLENOID-PILOT AND AIR-PILOT ACTUATED

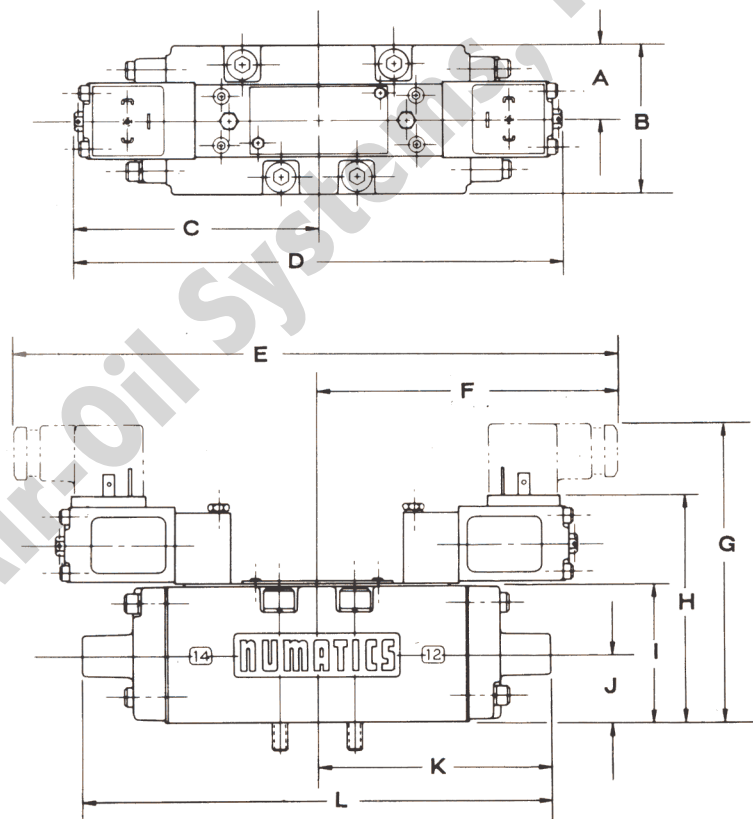

	ISO 1	ISO 2	ISO 3
A	20.8 (.82)	24.9 (.98)	31.8 (1.25)
B	41.9 (1.65)	50.0 (1.97)	63.5 (2.50)
C	97.2 (3.83)	102.9 (4.05)	103.1 (4.06)
D	194.8 (7.67)	205.5 (8.09)	206.2 (8.12)
E	219.5 (8.64)	230.1 (9.06)	230.9 (9.09)
F	109.7 (4.32)	115.1 (4.53)	115.3 (4.54)
G	109.7 (4.32)	112.5 (4.43)	124.2 (4.89)
H	81.8 (3.22)	84.6 (3.33)	96.3 (3.79)
I	46.2 (1.82)	49.3 (1.94)	59.4 (2.34)
J	22.4 (.88)	22.9 (.90)	28.4 (1.12)
K	68.1 (2.68)	72.1 (2.84)	99.1 (3.90)
L	136.1 (5.36)	144.3 (5.68)	197.9 (7.79)

Top Dimension = Millimeters
 Bottom Dimension
 (In Parenthesis) = Inches

INDIVIDUAL BASE DIMENSIONS AND PARTS

NUMATICS® ISO SERIES

SIDE PORTED BASE

SERIES	PORT SIZE	PART NUMBER
ISO 1	G 1/4"	103-544C
	1/4 NPTF	103-546C
	3/8 NPTF	103-548C
ISO 2	G 3/8"	103-549C
	3/8 NPTF	103-554C
ISO 3	G 1/2"	103-545C
	1/2 NPTF	103-547C

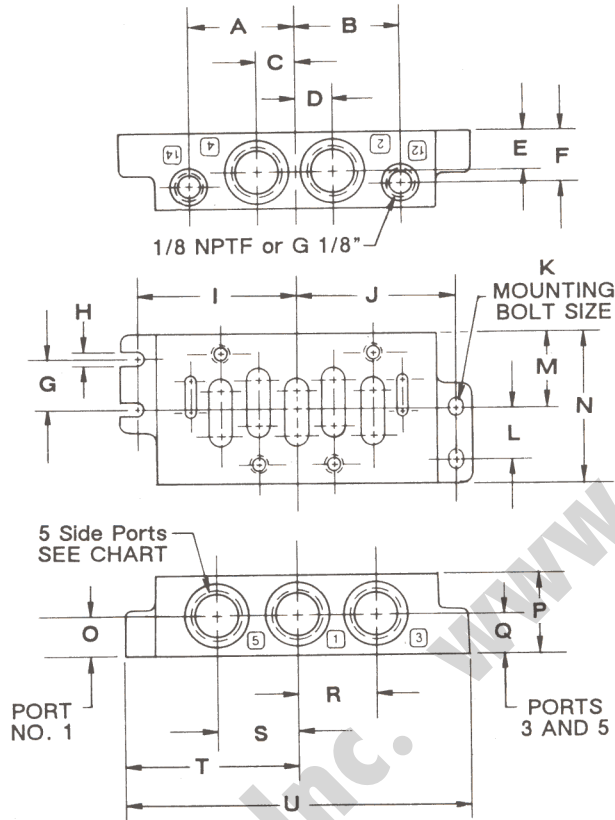

	ISO 1	ISO 2	ISO 3
A	32 (1.260)	36.5 (1.437)	45 (1.772)
B	32 (1.260)	36.5 (1.437)	45 (1.772)
C	12.5 (.492)	14 (.551)	16 (.630)
D	12.5 (.492)	14 (.551)	16 (.630)
E	11 (.433)	15 (.591)	16 (.630)
F	22 (.866)	31 (1.220)	22 (.866)
G	15 (.591)	15 (.591)	22 (.866)
H	5.5 (.217)	6.6 (.260)	6.3 (.248)
I	49 (1.930)	56 (2.20)	68 (2.677)
J	49 (1.930)	56 (2.20)	68 (2.677)
K	5mm (10)	6mm (1/4)	6mm (1/4)
L	15 (.591)	15 (.591)	22 (.866)
M	24 (.94)	28 (1.102)	32 (1.260)
N	48 (1.890)	56 (2.20)	64 (2.520)
O	11 (.433)	24 (.94)	16 (.630)
P	32 (1.260)	40 (1.575)	33 (1.30)
Q	19 (.748)	27 (1.063)	16 (.630)
R	24 (.945)	28 (1.102)	34 (1.339)
S	24 (.945)	28 (1.102)	34 (1.339)
T	55 (2.165)	62 (2.44)	74.5 (2.933)
U	110 (4.33)	124 (4.88)	149 (5.87)

BOTTOM PORTED BASE

SERIES	PORT SIZE	PART NUMBER
ISO 1	G 1/4"	103-542C
ISO 2	G 3/8"	103-557C
ISO 3	G 1/2"	103-543C
	1/2 NPTF	103-556C

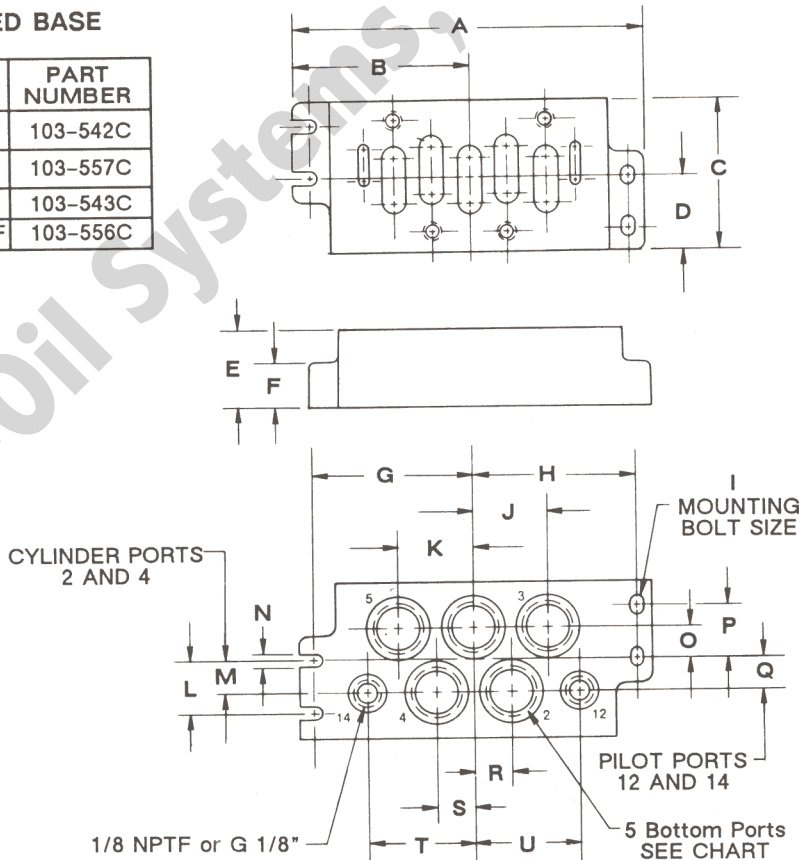

	ISO 1	ISO 2	ISO 3
A	110 (4.33)	124 (4.88)	149 (5.87)
B	55 (2.17)	112 (4.41)	74.5 (2.93)
C	46 (1.81)	56 (2.21)	64 (2.52)
D	23 (.906)	28 (1.102)	32 (1.26)
E	30 (1.18)	35 (1.38)	32 (1.26)
F	10 (.39)	13 (.51)	18 (.71)
G	49 (1.93)	56 (2.21)	68 (2.68)
H	49 (1.93)	56 (2.21)	68 (2.68)
I	5mm (10)	6mm (1/4)	6mm (1/4)
J	23 (.906)	28 (1.102)	32 (1.26)
K	23 (.906)	28 (1.102)	32 (1.26)
L	15 (.591)	15 (.591)	22 (.866)
M	11.5 (.453)	13.5 (.531)	13.5 (.531)
N	5.5 (.217)	6.5 (.226)	6.6 (.260)
O	11.5 (.453)	10 (.394)	13.5 (.53)
P	15 (.591)	15 (.591)	22 (.866)
Q	11.5 (.453)	10 (.394)	13.5 (.531)
R	11.5 (.453)	13 (.512)	16 (.630)
S	11.5 (.453)	13 (.512)	16 (.630)
T	31 (1.220)	37 (1.457)	45 (1.772)
U	31 (1.220)	37 (1.457)	45 (1.772)

numatics® ISO SERIES

MANIFOLD DIMENSIONS AND PARTS SIDE AND BOTTOM CYLINDER PORTS

NOTE: To Order Factory
Assembled Manifolds,
See Page 12.

Top Dimension = Millimeters
Bottom Dimension
(In Parenthesis) = Inches

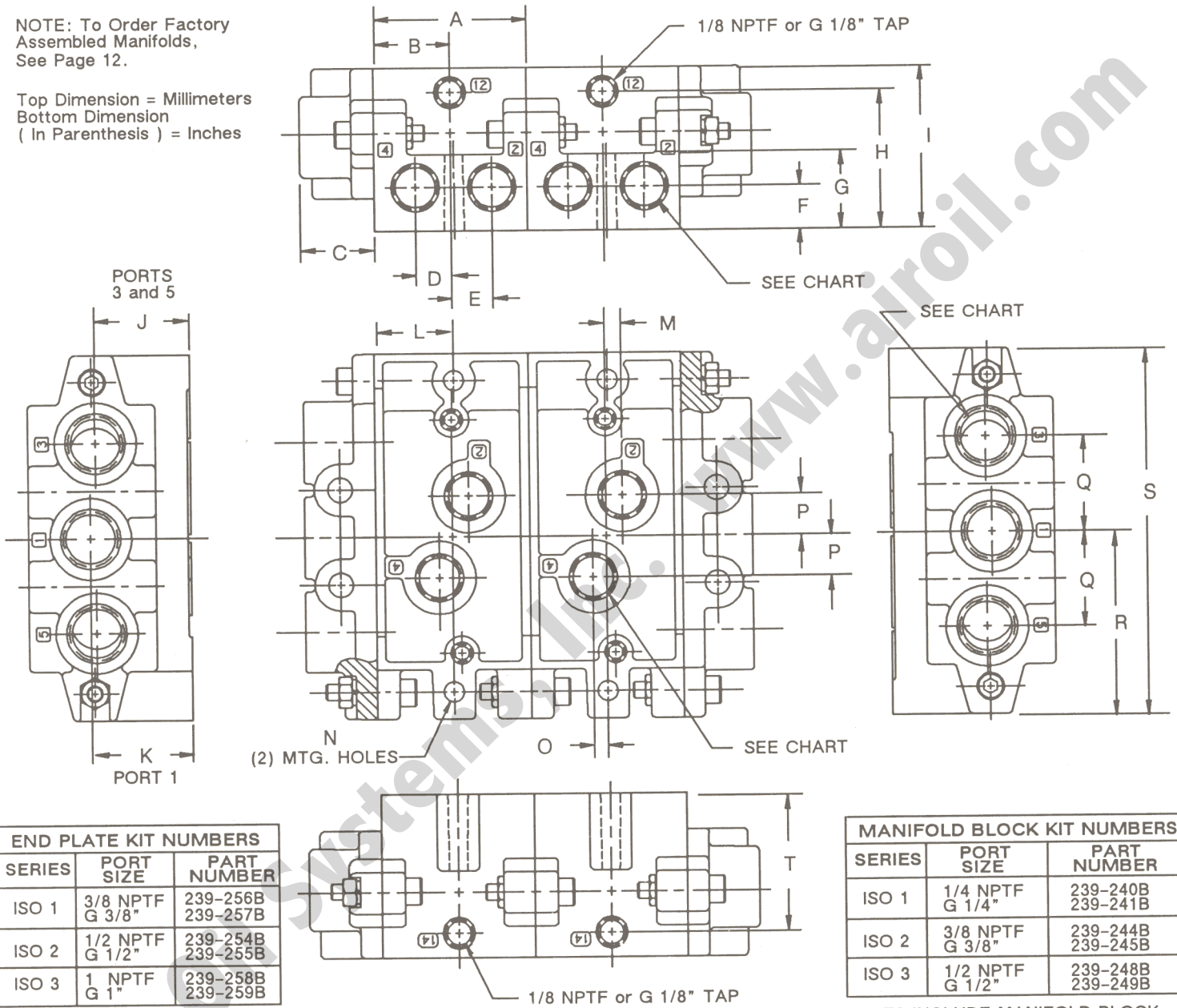

END PLATE KIT NUMBERS		
SERIES	PORT SIZE	PART NUMBER
ISO 1	3/8 NPTF G 3/8"	239-256B 239-257B
ISO 2	1/2 NPTF G 1/2"	239-254B 239-255B
ISO 3	1 NPTF G 1"	239-258B 239-259B

KIT INCLUDES BOTH END PLATES,
SOCKET HEAD SCREWS,
NUTS AND SEALS

MANIFOLD BLOCK KIT NUMBERS		
SERIES	PORT SIZE	PART NUMBER
ISO 1	1/4 NPTF G 1/4"	239-240B 239-241B
ISO 2	3/8 NPTF G 3/8"	239-244B 239-245B
ISO 3	1/2 NPTF G 1/2"	239-248B 239-249B

KITS INCLUDE MANIFOLD BLOCK,
SOCKET HEAD SCREWS,
NUTS, SEALS AND PIPE PLUGS

DIMENSIONS																				
SERIES	A	B	C	D	E	F	G	H	I	J	K	L	M	N	O	P	Q	R	S	T
ISO 1	43 (1.69)	21.5 (.85)	22 (.87)	9.6 (.38)	11.9 (.47)	13 (.51)	22.9 (.90)	40 (1.57)	50 (1.97)	25 (.98)	28 (1.10)	23 (.89)	7.5 (.29)	5.3 (.21)	1.5 (.06)	13 (.51)	28 (1.10)	55 (2.17)	110 (4.33)	40 (1.57)
ISO 2	56 (2.20)	28 (1.10)	26 (1.02)	13 (.51)	15 (.59)	16 (.63)	28.0 (1.1)	51 (2.0)	60 (2.36)	35 (1.38)	37 (1.46)	29 (1.14)	6.0 (.24)	6.6 (.26)	5.0 (.20)	15 (.59)	35 (1.38)	67.5 (2.66)	135 (5.31)	51 (2.0)
ISO 3	71 (2.79)	35.5 (1.40)	30 (1.18)	16.5 (.65)	19 (.75)	18 (.71)	31.8 (1.25)	56.5 (2.22)	66 (2.60)	41 (1.61)	44 (1.73)	36 (1.44)	8.0 (.31)	8.6 (.34)	6.0 (.24)	19 (.75)	52 (2.05)	95 (3.74)	190 (7.48)	56.5 (2.22)

MANIFOLD DIMENSIONS AND PARTS BOTTOM CYLINDER PORTS (VDMA SPECIFICATION NO. 24 345)



NOTE: To Order Factory Assembled Manifolds, See Page 12.

Top Dimension = Millimeters
Bottom Dimension (In Parenthesis) = Inches

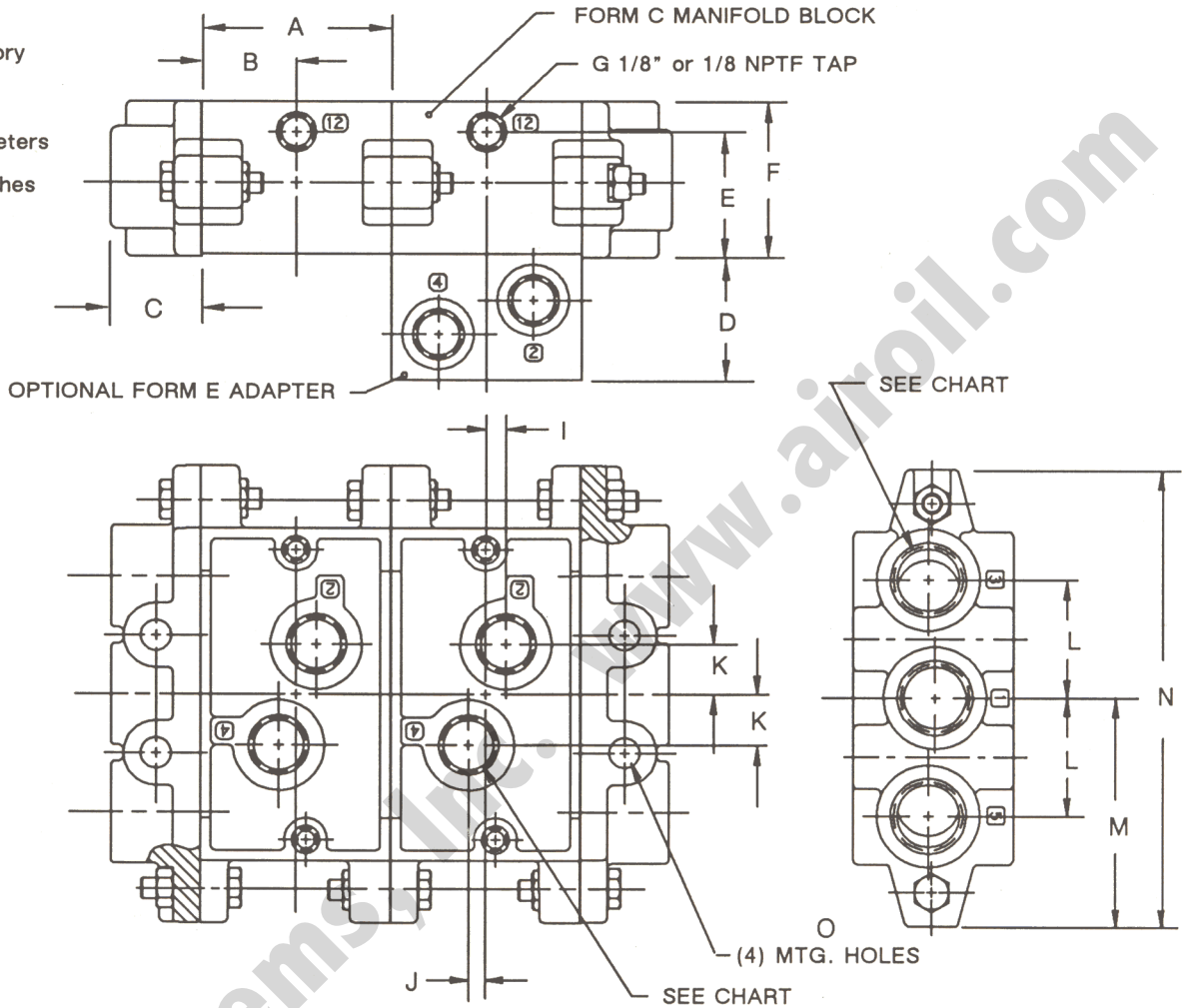

END PLATE KIT NUMBERS		
SERIES	PORT SIZE	PART NUMBER
ISO 1	3/8 NPTF G 3/8"	239-289B 239-290B
ISO 2	1/2 NPTF G 1/2"	239-291B 239-292B
ISO 3	1 NPTF G 1"	239-293B 239-294B

KIT INCLUDES BOTH END PLATES,
HEX HEAD SCREWS,
NUTS AND SEALS

MANIFOLD BLOCK KIT NUMBERS		
SERIES	PORT SIZE	PART NUMBER
ISO 1	1/4 NPTF G 1/4"	239-238B 239-239B
ISO 2	3/8 NPTF G 3/8"	239-242B 239-243B
ISO 3	1/2 NPTF G 1/2"	239-246B 239-247B

KITS INCLUDE MANIFOLD BLOCK,
HEX HEAD SCREWS, NUTS AND SEALS

DIMENSIONS															
SERIES	A	B	C	D	E	F	G	H	I	J	K	L	M	N	O
ISO 1	43 (1.69)	21.5 (.85)	22 (.87)	37 (1.46)	36 (1.42)	46 (1.81)	21 (.83)	24 (.94)	7.5 (.30)	1.50 (.06)	13 (.51)	28 (1.10)	55.1 (2.17)	110 (4.33)	6.3 (.25)
ISO 2	56 (2.20)	28 (1.10)	26 (1.02)	40 (1.57)	38 (1.50)	47 (1.85)	22 (.87)	24 (.94)	6.0 (.24)	5.0 (.20)	15 (.59)	35 (1.38)	67.5 (2.66)	135 (5.31)	9 (.35)
ISO 3	71 (2.79)	35.5 (1.40)	30 (1.18)	45 (1.77)	46 (1.83)	56 (2.20)	31 (1.22)	34 (1.34)	8.0 (.31)	6.0 (.24)	19 (.75)	52 (2.05)	95 (3.74)	190 (7.48)	12 (.47)

numatics®

ISO SERIES

PRESSURE REGULATORS

Numatics makes two different pressure control valves for regulating the pressure to valve units. The regulators are sandwich style and mount between the valve unit and any base of manifold mounting.

I. SINGLE PRESSURE (Type RS)

This assembly has a single regulator in the supply flow path. It receives line pressure from the (1) port of the base and supplies regulated pressure to the (1) port of the valve unit. Cylinder ports 2 and 4 and exhaust ports 3 and 5 are connected through the regulator back to the respective ports in the base or manifold, and function as in a standard valve.

II. DUAL PRESSURE (Type RD)

This assembly has two regulators for dual pressure applications. It takes line pressure from the (1) port of the base, and supplies it to the input of two regulators. The regulator outputs are supplied to ports 3 and 5 of the valve unit. Cylinder ports 2 and 4 are connected through the regulator back to ports 2 and 4 in the base. Common exhaust, now port 1 in the valve unit, is connected to port 3 in the base or manifold.

All regulators are available in four different pressure ranges as shown in the model selection chart below. Gages are included.

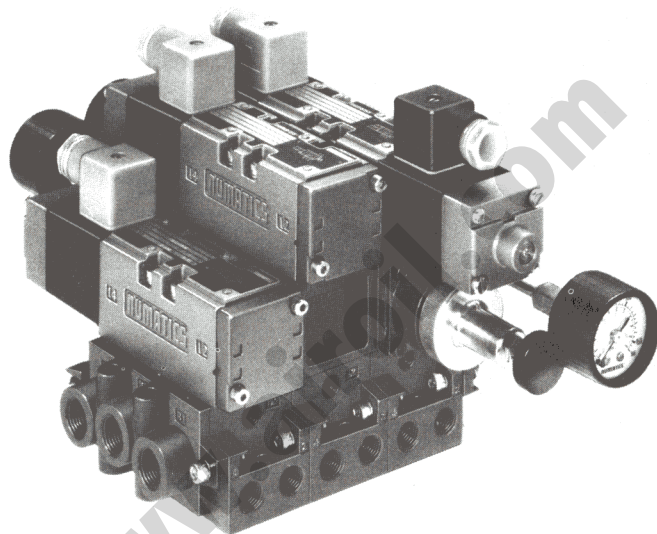

HOW TO ORDER

To order valves and regulators factory assembled, specify any valve from the model selection chart on page 5 and the regulator unit from the chart below.

NOTE: Dual regulators should not be used on valves with speed control units.

EXAMPLES:

I12BA4464N 24 VDC

I34SS4152G 120/60

I12RS10000

I34RD10000

Assembled

Assembled

OPERATING DATA

PRIMARY PRESSURE: 20.7 Bar (300 PSIG)

TEMPERATURE AND SERVICE: Same as valves.

REGULATOR SELECTION CHART

VALVE SERIES	REGULATOR TYPE	BASIC NUMBER	PRESSURE RANGE (Add to Basic Number)	SPECIAL OPTIONS (Add to Pressure Range)
ISO 1	SINGLE	I12RS	10000 = 0.7 - 9 Bar (10 - 130 PSIG) 30000 = 0.2 - 2 Bar (3 - 30 PSIG) 40000 = 0.35 - 4 Bar (5 - 60 PSIG) 60000 = 1.4 - 17 Bar (20 - 250 PSIG)	12H = Less Gage 16N = Jumper Plate on "14" End 16P = Jumper Plate on "12" End
	DUAL	I12RD		
ISO 2	SINGLE	I22RS		
	DUAL	I22RD		
ISO 3	SINGLE	I34RS		
	DUAL	I34RD		
EXAMPLE: ISO 1 Single Regulator, 0.2 - 2 Bar Secondary Pressure, Less the Standard Gage : I12RS3000012H NOTE: Regulators Include Gage, Fittings, Mounting Studs and Gasket.				

NUMATICS® ISO SERIES

PRESSURE REGULATORS

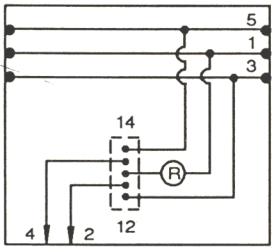
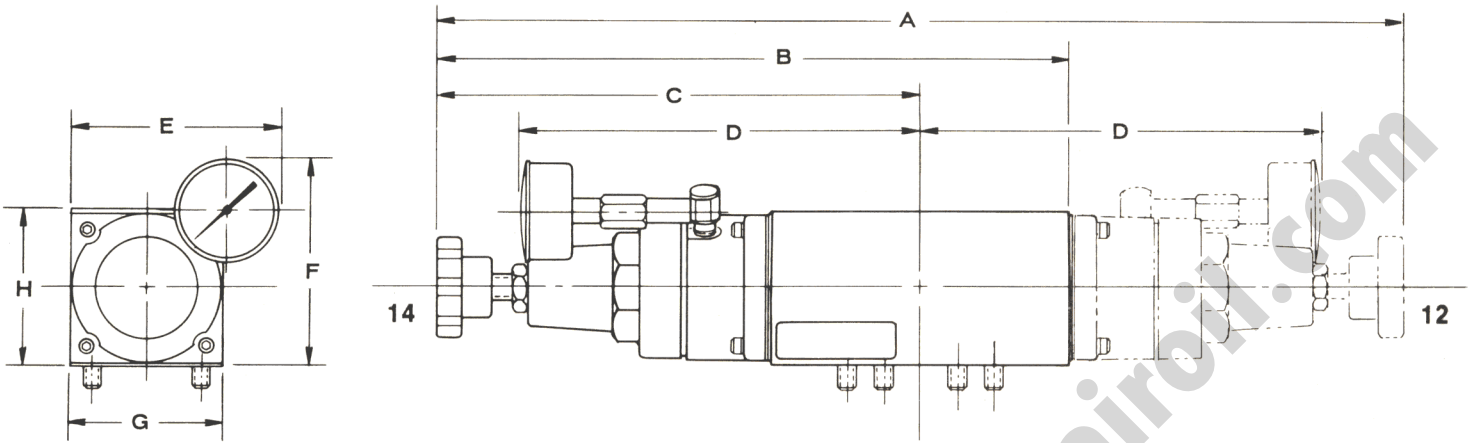

SINGLE REGULATOR

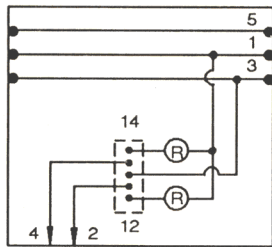

DUAL PRESSURE
REGULATOR

DIMENSIONS								
SERIES	A	B	C	D	E	F	G	H
ISO 1	267.5 (10.53)	180.1 (7.09)	133.8 (5.27)	161.0 (6.34)	58.4 (2.30)	59.2 (2.33)	41.9 (1.65)	43.2 (1.70)
ISO 2	2.75 (0.1085)	188.2 (7.41)	137.9 (5.43)	165.1 (6.50)	62.5 (2.46)	59.2 (2.33)	50.0 (1.97)	43.2 (1.70)
ISO 3	425.4 (16.75)	279.9 (11.02)	211.8 (8.38)	178.0 (7.01)	80.5 (3.17)	81.8 (3.22)	64.0 (2.52)	66.5 (2.62)

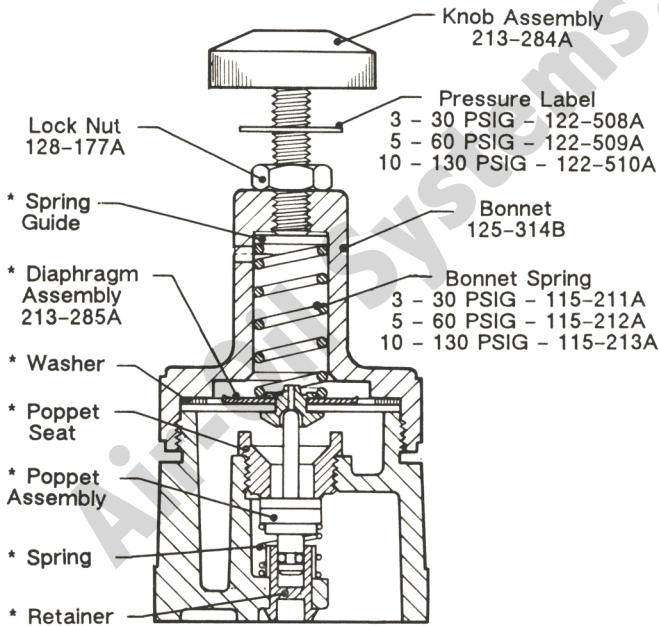

ISO 1 AND 2 REGULATOR UNIT
REPAIR KIT NO. 229-640A
INCLUDES ALL PARTS
MARKED WITH AN ASTERISK

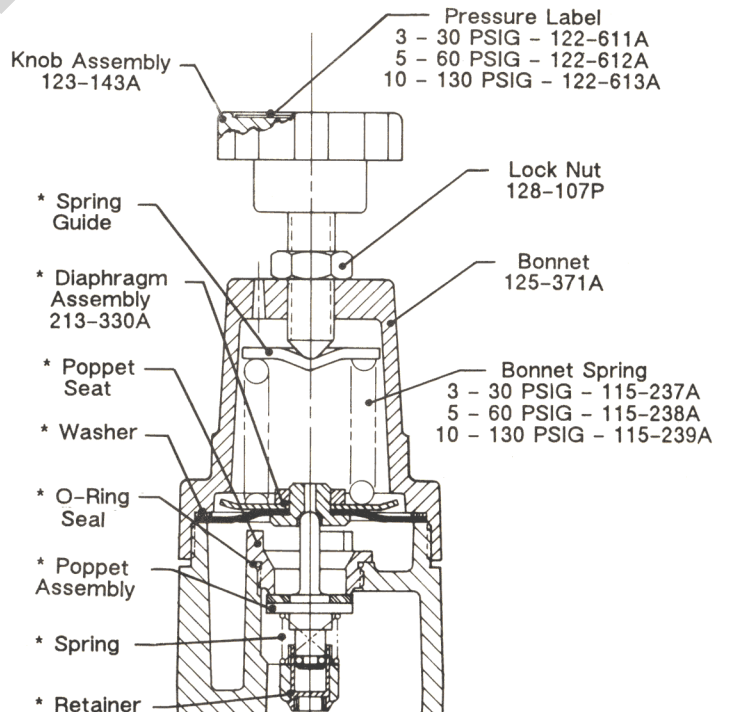

ISO 3 REGULATOR UNIT
REPAIR KIT NO. 229-907A
INCLUDES ALL PARTS
MARKED WITH AN ASTERISK

numatics® ISO SERIES

HOW TO ORDER FACTORY ASSEMBLED MANIFOLDS AND MANIFOLD ACCESSORIES

HOW TO ORDER FACTORY ASSEMBLED MANIFOLDS

All standard manifolds offer side and bottom cylinder ports. These ports and end plates are available tapped either NPTF or G. To order a factory assembled manifold, it is necessary to order the assembly kit and the valve or regulator required at each station. The assembly kit includes the end plates plus assembly and testing. All kits are prefixed "AK", followed by the valve

series, a dash, The number or stations, and either "N" for NPTF or "G" for G tapped ports. Select assembly kits from the following chart. A maximum of 12 stations is recommended.

All VDMA manifolds have bottom tapped cylinder ports only. These manifolds are also available with either NPTF or G tapped Ports.

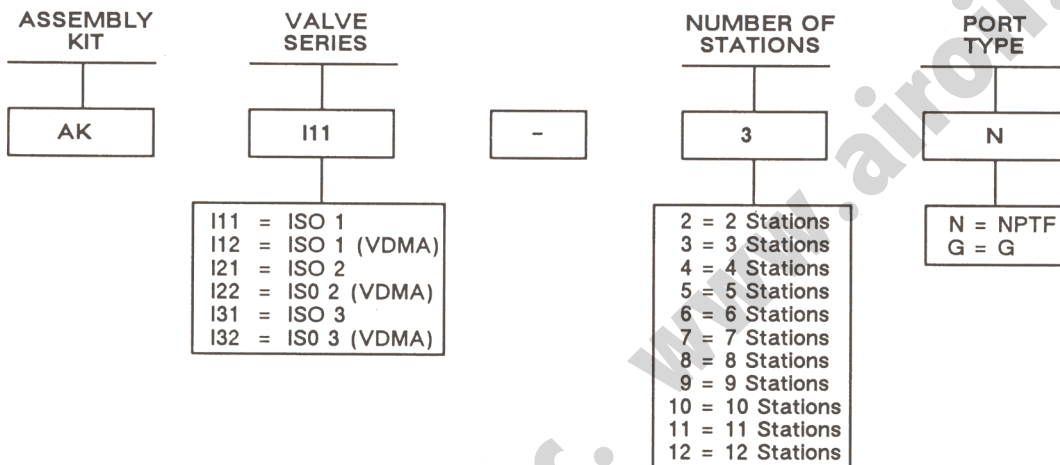

EXAMPLE:

ISO 1 Manifold with Side and Bottom Ports

- (1) AKI11-3N Assembly Kit
- Station 1: (1) I12BA4154N 24 VDC
- Station 2: (1) I12BB4154N 24 VDC
- Station 3: (1) I12BA4154N 24 VDC
- (1) I12RS1000O Assembled

EXAMPLE:

ISO 3 Manifold, Type VDMA

- (1) AKI32-3G Assembly Kit
- Station 1: (1) I34BA41A4G 24 VDC
- Station 2: (1) I34BB41A4G 24 VDC
- Station 3: (1) I34BA41A4G 24 VDC
- (1) I34RS1000O Assembled

MANIFOLD ACCESSORIES

GALLERY BLOCKING DISC KITS

May be used to block any gallery in a manifold system.

DISC KIT NUMBERS	
SERIES	PART NUMBER
ISO 1	239-251A
ISO 2	239-252A
ISO 3	239-253A



BLANK STATION PLATE KIT

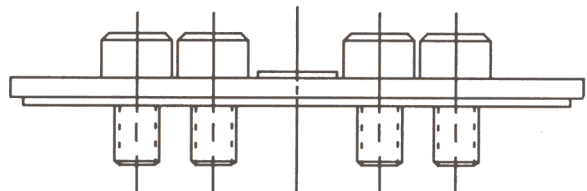

PLATE KIT NUMBERS	
SERIES	PART NUMBER
ISO 1	239-150A
ISO 2	239-178B
ISO 3	239-153B

**SERVICE KITS
SLEEVE ASSEMBLIES**

**numatics®
ISO SERIES**

SERVICE KITS – Kits include all internal parts except solenoid and sleeve assemblies

VALVE SERIES			VALVE DESCRIPTION
ISO 1	ISO 2	ISO 3	
I1S-K1	I2S-K1	I3S-K1	Direct acting, single solenoid, spring return
I1S-K2	I2S-K2	I3S-K2	Direct acting, double solenoid, detented
I1S-K3	I2S-K3	I3S-K3	Direct acting, double solenoid, 3-position
I1B-K1	I2B-K1	I3B-K1	Solenoid-pilot and air pilot actuated, single solenoid, spring return
I1B-K2	I2B-K2	I3B-K2	Solenoid-pilot and air pilot actuated, double solenoid, detented
I1B-K3	I2B-K3	I3B-K3	Solenoid-pilot and air pilot actuated, all double solenoid, 3-position
I1B-K4	I2B-K4	I3B-K4	Solenoid-pilot actuated, differential air return

SLEEVE ASSEMBLIES – Includes seals

SERIES	DIRECT SOLENOID ACTUATED	SOL.-PILOT AND AIR PILOT ACTUATED	FUNCTION
ISO 1	209-313A	209-314A	Single solenoid, spring return
	209-315A	209-314A	Double solenoid, detented
	209-344A	209-347A	Double solenoid, 3-position, 5 function
	209-345A	209-348A	Double solenoid, 3-position, 6 function
	----	209-316A	Single solenoid, differential air return
ISO 2	209-365B	209-364B	Single solenoid, spring return
	209-366B	209-364B	Double solenoid, detented
	209-367B	209-370B	Double solenoid, 3-position, 5 function
	209-368B	209-371B	Double solenoid, 3-position, 6 function
	----	209-363B	Single solenoid, differential air return
ISO 3	209-321A	209-320A	Single solenoid, spring return
	209-319A	209-320A	Double solenoid, detented
	209-337A	209-340A	Double solenoid, 3-position, 5 function
	209-338A	209-341A	Double solenoid, 3-position, 6 function
	----	209-318A	Single solenoid, differential air return

numatics® ISO SERIES

SOLENOID ASSEMBLIES AND PILOT PLUGGING ARRANGEMENTS

DIRECT ACTING SOLENOID ASSEMBLIES – Solenoid only, no override assembly

VOLTAGES	SERIES			
	ISO 1	ISO 2	ISO 3	
			SINGLE	DOUBLE
110-120/60; 100-115/50	228-726B	228-726B	228-720C	228-723C
220-240/60; 200-230/50	228-725B	228-725B	228-719C	228-722C
24/50-60	228-727B	228-727B	228-721C	228-724C
12 VDC	225-366B	225-366B	----	----
24 VDC	225-367B	225-367B	----	----

SOLENOID-PILOT CAPSULE ASSEMBLIES (For all valve series)

VOLTAGES	PART NUMBER
110-120/60; 100-115/50	237-587B
220-240/60; 200-230/50	237-588B
24/50-60	237-586B
24 VDC (7.5 Watt)	226-718B
24 VDC (4.0 Watt)	226-734B

PILOT PLUGGING ARRANGEMENTS

All air piloted valves are shipped with external pilot supply to ports 12 and 14 in the mounting.

All solenoid-piloted valves are shipped with internal pilot supply from port 1 in the mounting. If supply air is piped to ports 3 or 5, or if external pilot supply is required, the valve must be converted.

Conversion is made very easily by removing the end caps and positioning the gasket so the tab points toward the appropriate port number.

Refer to the chart at the right and drawing below.

PILOT SUPPLY OPTION	GASKET TAB LOCATION	
	"14" END	"12" END
I. All Air Piloted Valves External Pilot to Ports 12 and 14	14	12
II. Solenoid Piloted Valves		
a. Internal from Port 1	1	1
b. Internal from Port 3	0	3
c. Internal from Port 5	5	0
d. External from Port 14 In the mounting	14	0
e. External from either pilot port in the pilot adapter	0	0

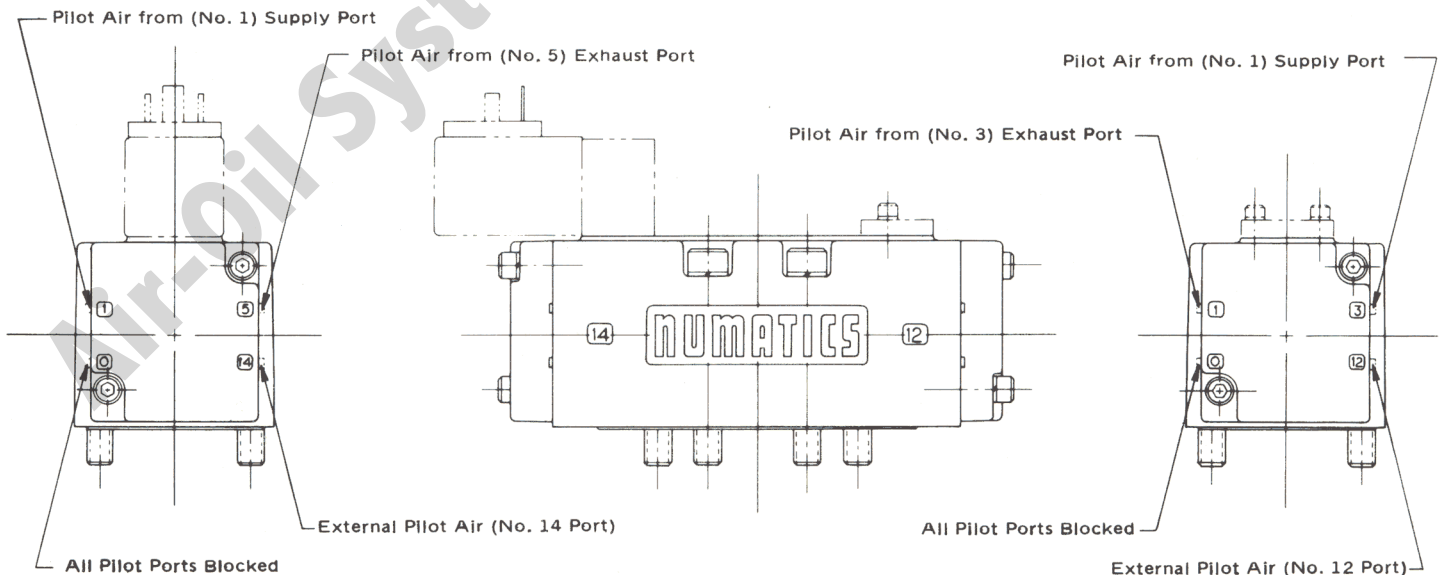

NOTE: Direct solenoid actuated valves are not affected by the gasket position.

FLOW CONTROL ACCESSORIES

numatics® ISO SERIES

SPEED CONTROL KITS

The ISO speed control kits mount between the valve unit and the base or manifold mounting. The 3 and 5 ports of the unit contain needle valves which can be adjusted to throttle the flow of exhaust air out of the valve unit. Thus, the speeds of the two strokes of a cylinder piston can be adjusted independently. Locknuts prevent the needles from moving.

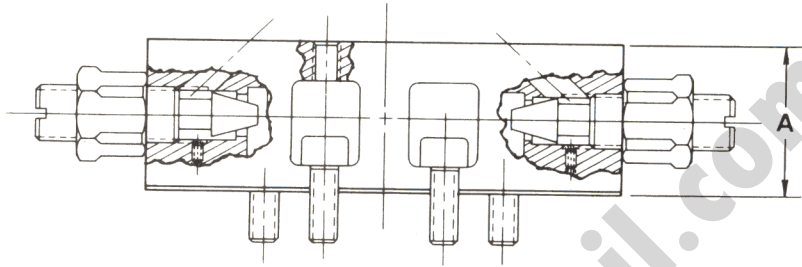

SPEED CONTROL KIT NUMBERS		
SERIES	PART NUMBERS	DIMENSION "A"
ISO 1	239-127A	35.5 mm (1.40")
ISO 2	239-123C	37.0 mm (1.46")
ISO 3	239-126A	40.6 mm (1.60")

METERING VALVES

MODEL SELECTION AND ENVELOPE DIMENSIONS

MODEL NUMBER	A.N.S.I. SYMBOL	PORT SIZE	FLOW CAPACITY	DIMENSIONS		
				A	B	C
MV-25		1/4 NPTF	Cv = 1.80	35 (1.37)	38 (1.50)	17.5 (.69)
MV-37		3/8 NPTF	Cv = 1.80	33 (1.31)	38 (1.50)	17.5 (.69)
MV-50		1/2 NPTF	Cv = 3.38	41 (1.62)	51 (2.00)	22.1 (.87)

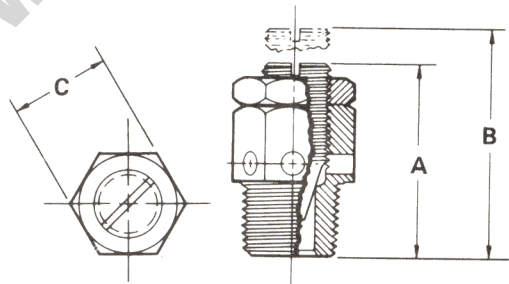

IN-LINE FLOW CONTROL VALVES

MODEL SELECTION AND ENVELOPE DIMENSIONS

MODEL NUMBER	A.N.S.I. SYMBOL	PORT SIZE	FLOW CAPACITY		DIMENSIONS		
			Free	Controlled	Length	Width	Height
2FC2		1/4 NPTF	Cv = 2.3	Cv = 2.0	59 (2.34)	27 (1.06)	56 (2.21)
3FC2		3/8 NPTF	Cv = 2.7	Cv = 2.4	59 (2.34)	27 (1.06)	56 (2.21)
4FC3		1/2 NPTF	Cv = 6.0	Cv = 5.5	83 (3.28)	38 (1.50)	81 (3.17)

Model numbers shown have NPTF ports. Add "G" if ports are to be tapped "G".

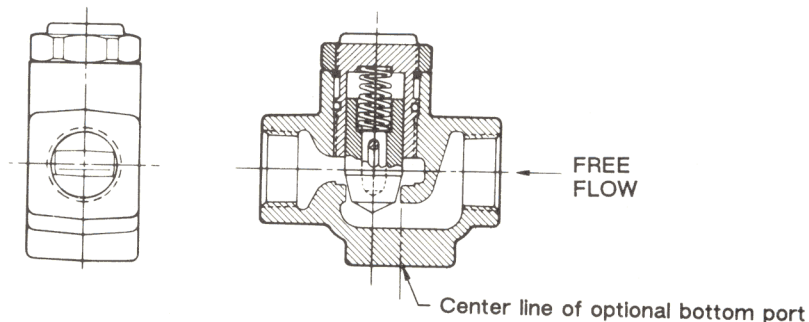

ADD "B" FOR OPTIOAL BOTTOM PORT