

actuators

R Series

Rack and Pinion Style Rotary Actuator Line



numatics®

Table of Contents

NUMATICS®

R Series	3-18
Features and Benefits	3
How to Order	4
Standard Specifications	5
Options	6
Cushions	6
Bumpers	6
Shock Absorbers	6
Mounting Options	7
Shaft Seal Cover and Pilot Ring	7
Shaft Options	7
Kinetic Energy Basic Formula	8
Size and Selection Example	9
Specifications	10
Port and Cushion Locations	10
Multi-Position Rotary Actuators	11-13
Switch Information	14
R series Global Switches	15-16
R series World Switches	17-18

Air-Oil Systems, Inc. www.airoil.com



The **R Series** is a heavy-duty rack and pinion style rotary actuator that is designed to excel in the most rigid applications. The R Series includes a high torque-to-size ratio as well as accurate positioning.

Rack and Pinion

The **rack** and **pinion** is made from high strength alloy steel. It is induction hardened for long life. The geometry factors of the rack and pinion have been balanced to ensure equal wear, which provides maximum gear life. The pinion shaft includes a male key as standard offering.

Ball Bearings

The **ball bearings** are sealed and pre-lubed in an effort to prevent contamination from negatively affecting the operation. They are sized to except high loads and still retain smooth maintenance free operation.

Rack Bushing

The **rack bushing** is made from bearing bronze. The durability of the bushing enables it to support nearly the full length of the rack. Furthermore, we have included a small gap to allow grease/lubrication to be added.

Tube

The profile **tube** is hard coat anodized. The hard coating is an electro-chemical process, which produces a very dense surface of aluminum oxide. This surface has extreme hardness (60 RC.), excellent wear and corrosion resistance, and low coefficient of friction.

End Caps

The **end caps** are accurately machined from (6061-T6) solid aluminum bar stock. They are anodized for corrosion resistance. Additionally, port positioning is extremely flexible.

Piston

The solid aluminum alloy **piston** is strong and durable. A magnet groove is standard allowing for easy field conversation.

Piston Seal

The **piston seal** is a carboxylated nitrile with Teflon® compound for self-lubricating. The U-cup type seal construction is proven and durable.

Wear Band

The **wear band** is a stable, lubricating strip located on the piston.

Grease Opening

A 1/4-28 tapped hole (which is plugged) is provided for future installation of an optional grease fitting. Note that the unit is pre-lubed.

Teflon® is a registered trademark of DuPont™. For detailed information regarding the properties of Teflon®.



Standard Specifications:

- Bore sizes from 1" through 3-1/4"
- Nominal pressure rating is 150 psi air
- Standard rotations are: 45°, 90°, 180°, 270°, and 360°
- Minimum breakaway pressure: 5 psi non-cushioned, 10 psi cushioned
- Standard temperature -10°F to 165°F (-23°C to 74°C)
- NPTF ports
- Flexible port locating

The keyway at position 12:00, is always the mid-rotation of the actuator unless otherwise specified.



R Series Rotary Actuator

NUMATICS®

How to Order

S AR K-180 1 C-C AA 0

Mounting

- F = Front Flange
- R = Rear Flange
- P = Pilot Ring
- B = Bottom Flange
- S = Standard Mount

Type

- AR = Single Rack
- BR = Double Rack
- CR = 3 Position Single Rack
- DR* = 4 Position Single Rack
- ER** = 5 Position Single Rack
- * Must specify X dimension.
- ** Must specify X and Y dimensions.

Size

- E = 1" Bore
- K = 1-1/2" Bore
- L = 2" Bore
- M = 2-1/2" Bore
- P = 3-1/4" Bore

Degrees Rotation

- 045 = 45°
- 090 = 90°
- 180 = 180°
- 270 = 270°
- 360 = 360°
- Any degree of rotation can be specified.

Consult factory for rotations of or greater than 1000°.

Rod End Code

- 1 = Single Male Keyed (Std)
- 2 = Single Female Keyed
- 3 = Double Male Keyed
- 4 = Preloaded Keyway

Magnetic Piston

- 0 = No Magnet
- 2 = Magnet

Options

- AA = No Options
- BA = Bumpers Both Directions
- BC = Bumpers Counterclockwise
- BH = Bumpers Clockwise
- KA* = Angle Adjustment Both Directions
- KC* = Angle Adjustment Counterclockwise
- KH = Angle Adjustment Clockwise
- PP = Polypak Piston Seals
- SA = Shock Absorbers Both Directions
- SC = Shock Absorbers Counterclockwise
- SH = Shock Absorbers Clockwise
- SS = Shaft Seal Covers
- VA = High Temperature Seals
- * N/A with the SA, SC, and SH options

Cushions

Position	Standard	1	2	3	4
No Cushions	A	A	A	A	A
CW and CCW	B	C	D	E	E
CW	F	G	H	J	J
CCW	K	L	M	N	N

CW = Clockwise
CCW = Counter-clockwise

Ports

Position	Size Code			
	1/8	1/4	3/8	1/2
1	B	C	D	E
2	H	I	J	K
3	N	O	P	Q
4	T	U	V	W

Cushion and Port Positions

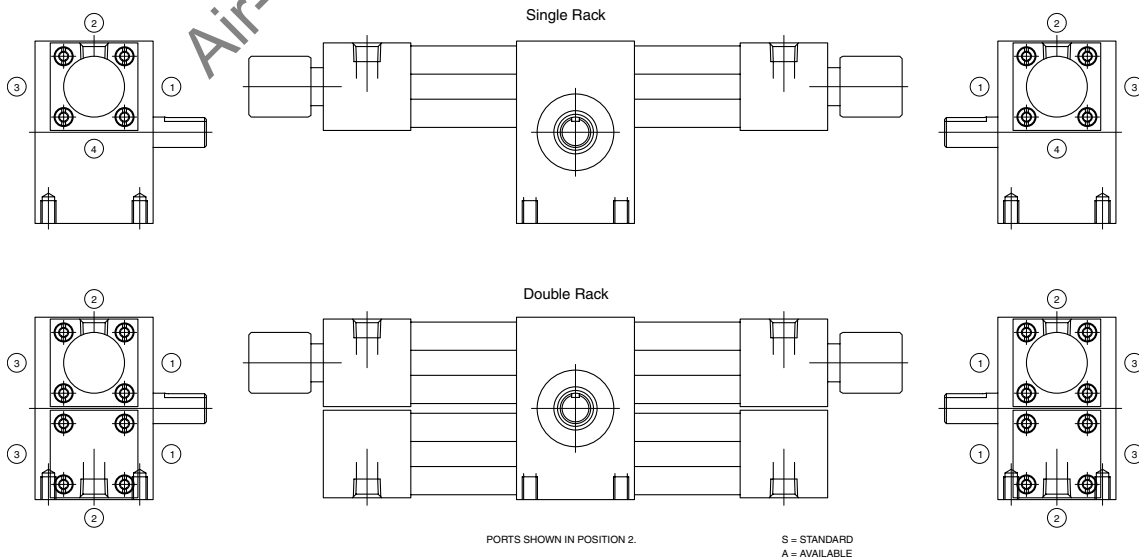

NOTE: Consult factory for repair kit information.



Standard Specifications

Maximum operating pressure: 150 psi pneumatic

Standard rotations: 45°, 90°, 180°, 270°, 360° and other rotations optional

Maximum breakaway pressure: 5 psi non-cushion, 10 psi cushioned

Operating temperature: 0° F to 180° F (standard seals)
-20° F to 400° F (viton seals)

BORE	NUMBER OF RACKS	MODEL	THEORETICAL TORQUE OUTPUT (in-lbs)			DISPLACEMENT CU. IN./DEG. OF ROTATION	"MAX. ANGULAR BACKLASH, MINUTES"	MAX. ROTATIONAL TOTAL (DEGREES)
			50 psi	100 psi	150 psi			
1"	1	SARE	19	39	59	0.007	50	10
1"	2	SBRE	39	79	118	0.014	50	10
1 1/2"	1	SARK	59	118	177	0.021	40	8
1 1/2"	2	SBRK	118	236	353	0.042	40	8
2"	1	SARL	141	282	424	0.049	30	6
2"	2	SBRL	282	565	848	0.099	30	6
2 1/2"	1	SARM	276	552	828	0.096	30	6
2 1/2"	2	SBRM	552	1104	1656	0.193	30	6
3 1/4"	1	SARP	570	1141	1711	0.199	15	4
3 1/4"	2	SBRP	1141	2281	3422	0.398	15	4

Allow 10% for friction loss.

Standard Mount

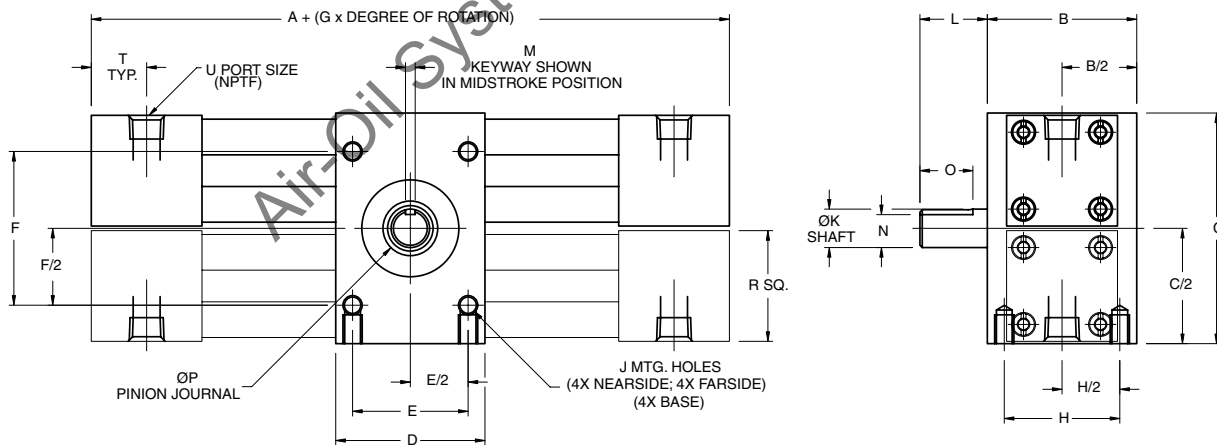

Dimensions

BORE	A	B	C	D	E	F	G	H	J	K	L	M	N	O	P	R	T	U	V
1"	7.50	2.00	3.00	2.00	1.50	2.00	0.01746	1.50	1/4-20 X 3/8 DEEP	.500/.499	0.88	.125/.127	.430/.425	.625	0.59	1.44	0.75	1/8	0.75
1-1/2"	8.50	3.00	4.25	3.00	2.00	3.00	0.02328	2.00	5/16-18 X 1/2 DEEP	.875/.874	1.88	.188/.190	.771/.761	1.50	0.98	2.00	0.75	1/4	1.13
2"	9.50	3.00	5.00	4.00	2.50	3.50	0.03124	2.00	3/8-16 X 1/2 DEEP	1.125/1.124	1.88	.250/.252	.986/.976	1.50	1.18	2.44	0.75	1/4	1.25
2-1/2"	9.75	3.50	6.00	4.00	2.50	4.50	0.03926	2.00	1/2-13 X 3/4 DEEP	1.375/1.374	2.25	.313/.315	1.201/1.191	1.75	1.57	2.94	0.75	1/4	1.50
3-1/4"	11.25	5.00	8.00	5.00	3.00	5.00	0.04800	2.50	3/4-10 X 1 DEEP	1.750/1.749	3.50	.375/.377	1.542/1.532	3.00	1.77	3.75	0.88	3/8	1.94



R Series Rotary Actuator

NUMATICS®

Options

Rotation Adjust

Rotation adjusting knobs can be added to control rotation more precisely. They can be used on both ends or on either end individually. Rotation adjusters can be used in conjunction with cushions. Their "high tech" style makes rotation adjustment easy to do without tools. The metric set screw in the side of knob securely locks the rotation setting. Thus, the rotation is very easy to adjust, but cannot be changed without a metric allen wrench. When used with cushions, maximum rotation adjustment will still allow at least 20° of rotation to be in cushion.

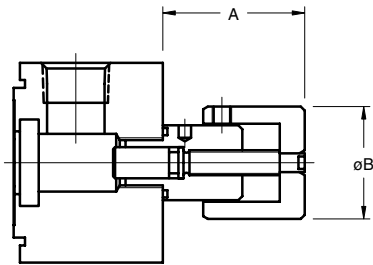

BORE	A	B	DEGREE OF ROTATION PER END
1"	1.43	1.13	43
1 1/2"	1.43	1.13	32
2"	2.22	1.75	40
2 1/2"	2.22	1.75	32
3 1/4"	2.67	2.35	32

Cushions

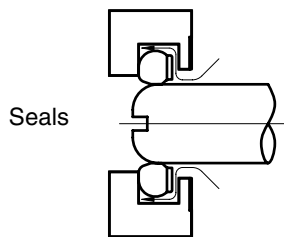

Into Cushion

Our cushion seal has a built-in function. It seals in one direction and permits full flow in the opposite direction.

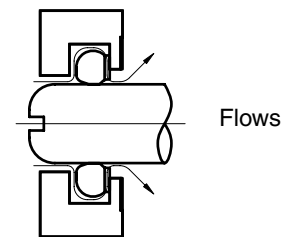

Out of Cushion

Cushions can be added to meter deceleration. Cushion adjustment needles can be put in any quadrant. Normally, cushions will be added to only one half of the double rack unit. The cushion and its operation is very similar to our current A series design. Rotation adjust can be used in conjunction with cushions. Cushions and Shock absorbers together are not available.

Bumpers

Bumper seals can be added to reduce impact. The bumper and seal are one piece. Bumpers can be used in conjunction with cushions if necessary.

NOTE: Cannot be used with rotation adjustment.

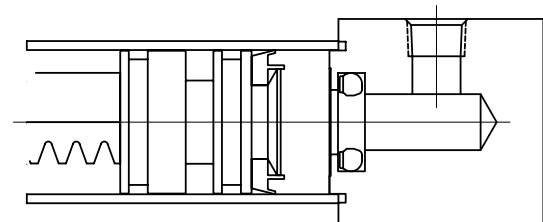

Shock Absorbers

Hydraulic shock absorbers can be added to reduce noise and large impacts. Shocks are fixed orifice self-compensating type. The 3 1/4" bore rotary actuator will not have this option. Cushions and shock absorbers together are not available.

NOTE: Shock cannot be adjusted.

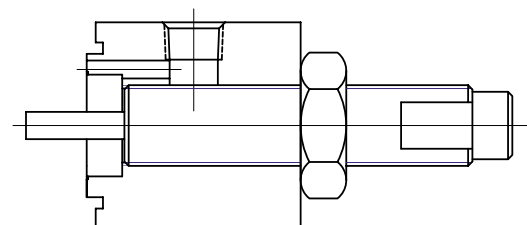



Mounting Options Flanges

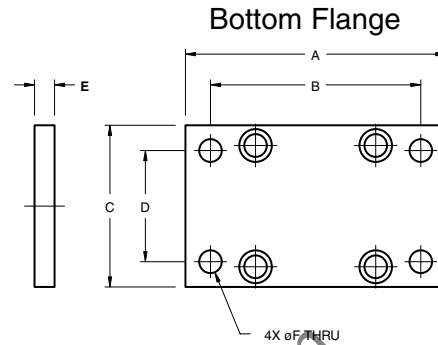
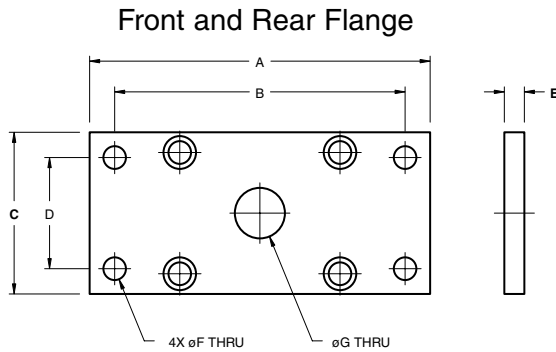

BORE	A	B	C	D	E	F	G
1"	4.25	3.63	2	1.38	0.25	9/32	5/8
1 1/2"	5.75	5.13	3	2.13	0.44	13/32	1
2"	6.50	5.88	4	3.38	0.44	13/32	1 1/4
2 1/2"	8.25	7.25	4	3.00	0.44	17/32	1 5/8
3 1/4"	12.00	10.00	5	3.00	0.75	25/32	2

BORE	A	B	C	D	E	F
1"	3.25	2.63	2	1.38	0.25	9/32
1 1/2"	4.50	3.88	3	2.13	0.44	13/32
2"	4.50	3.88	4	3.38	0.44	13/32
2 1/2"	5.50	4.50	4	3.00	0.44	17/32
3 1/4"	8.00	6.50	5	3.50	0.75	25/32

Shaft Seal Cover and Pilot Ring

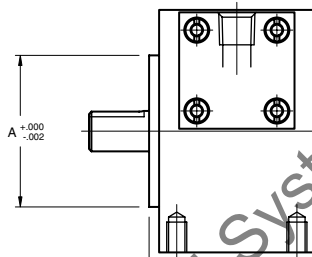

BORE	A	B
1"	1.875	0.125
1 1/2"	3.000	0.250
2"	3.250	0.250
2 1/2"	3.625	0.250
3 1/4"	4.480	0.250

The pilot ring and the shaft seal cover are dimensionally the same. Pilot rings are used to help center the shaft to the work piece. Shaft seal covers are used to prevent contamination to the ball bearings. They can only be used on single and double male shafts.

Shaft Options

Double Male Keyed

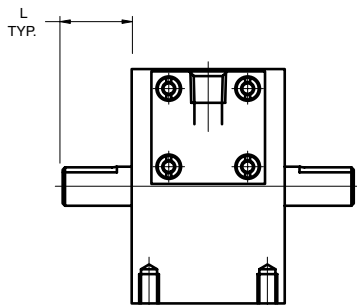

BORE	L
1"	0.875
1 1/2"	1.875
2"	1.875
2 1/2"	2.250
3 1/4"	3.500

BORE	A	B	C	D	E
1"	1.81	0.59	0.250	N/A	N/A
1 1/2"	2.69	0.98	0.500	0.125	0.560
2"	2.72	1.18	0.688	0.187	0.780
2 1/2"	3.13	1.57	0.813	0.250	0.901
3 1/4"	4.56	1.77	1.125	0.250	1.247

Single Female Keyed

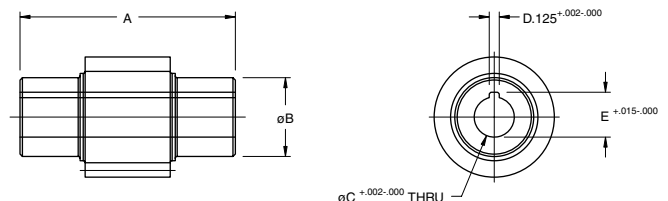



R Series Rotary Actuator

NUMATICS®

Kinetic Energy Basic Formula

$$KE = 1/2 J\omega^2$$

$$\omega = 0.035 \times \frac{\text{Angle traveled (degrees)}}{\text{Rotation time (seconds)}}$$

Where:

KE	=	Kinetic Energy (in-lb)
J	=	Rotational mass moment of inertia (in-lb-sec ²) (Dependent on physical size of object and weight)
ω	=	Peak Velocity (rad/sec) (Assuming twice average velocity)
W	=	Weight of load (lb)
g	=	Gravitational constant = 386.4 in/sec ²
r	=	Radius of gyration (in)

Moments of Inertia

Maximum Kinetic Energy Rating for Models Based on Configuration (in-lb)

BORE	STANDARD	ROTATION ADJUSTERS	CUSHIONS	SHOCK ABSORBERS (PER CYCLE/PER HOUR)
1"	0.50	0.50	5	150/300,000
1 1/2"	2.00	2.00	20	225/400,000
2"	4.00	4.00	40	600/600,000
2 1/2"	7.00	7.00	70	600/600,000
3 1/4"	15.00	15.00	150	N/A

<p>Thin Disk-End mounted on center</p> $J = \frac{W}{g} \times \frac{r^2}{4}$	<p>Thin Disk Mounted on center</p> $J = \frac{W}{g} \times \frac{r^2}{2}$	<p>Point Load</p> $J = \frac{W}{g} \times r^2$
<p>Thin Rectangular Plate Mounted on center</p> $J = \frac{W}{g} \times \frac{a^2}{12}$	<p>Thin Rectangular Plate</p> $J = \frac{W1}{g} \times \frac{4a^2 + c^2}{12} + \frac{W2}{g} \times \frac{4b^2 + c^2}{12}$	<p>Slender Rod</p> $J = \frac{W1}{g} \times \frac{a^2}{3} + \frac{W2}{g} \times \frac{b^2}{3}$



Size and Selection Example

Point load application

W=5 lb. load

r=12 inch arm length

Want to use 1 1/2 bore rotary actuator

Need to rotate 180 degrees in 2 seconds

Should I use bumpers, cushions, shocks, or none of these?

From Catalog:

$$\omega = 0.035 \times \frac{\text{Angle traveled (DEG)}}{\text{Rotation time (SEC)}}$$

$$\omega = 0.035 \times \frac{180 \text{ DEG}}{2 \text{ SEC}}$$

$$\omega = \frac{3.15}{\text{SEC}}$$

$$J = \frac{W}{g} \times r^2$$

$$J = 5 \text{ LB} \frac{\text{SEC}^2}{386.4 \text{ IN}} \times \text{IN}^2$$

$$J = 1.86 \text{ IN-LB-SEC}^2$$

$$\text{KE} = 1/2 J\omega^2$$

$$\text{KE} = \frac{1}{2} \times 1.86 \text{ IN-LB-SEC}^2 \times \left(\frac{3.15}{\text{SEC}}\right)^2$$

$$\text{KE} = 9.23 \text{ IN-LB}$$

Looking at Kinetic Energy Rating Chart:

Maximum KE=20 IN-LBS for a 1 1/2" bore rotary with cushions

Therefore, application requires cushions.

Point Load

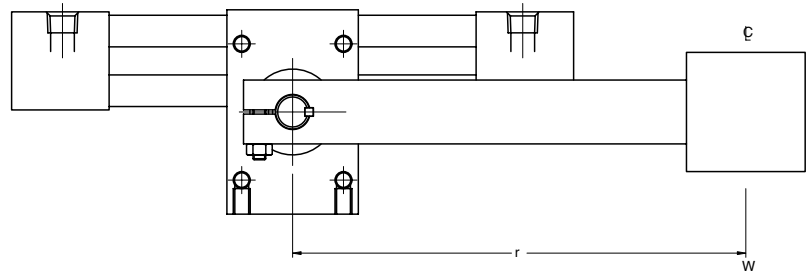

$$J = \frac{W}{g} \times r^2$$

Air-Oil Systems, Inc. www.airoil.com

Maximum Kinetic Energy Rating
for Models Based on Configuration (in-lb)

BORE	STANDARD	STROKE ADJUSTERS	CUSHIONS	SHOCK ABSORBERS (PER CYCLE/PER HR.)
1"	0.50	0.50	5	150/300,000
1 1/2"	2.00	2.00	20	225/400,000
2"	4.00	4.00	40	600/600,000
2 1/2"	7.00	7.00	70	600/600,000
3 1/4"	15.00	15.00	150	N/A



R Series Rotary Actuator

NUMATICS®

Specifications

Unit Weights (lbs)

MODEL	ROTATION (DEGREES)			
	90	180	270	360
SARE	3	3	3	3
SBRE	4	4	4	5
SARK	9	9	10	10
SBRK	12	13	14	15
SARL	14	15	16	17
SBRL	20	22	24	27
SARM	22	23	25	27
SBRM	31	34	38	41
SARP	45	47	49	52
SBRP	62	67	72	77

Bearing Load Capacities

BORE	RADIAL LOAD (lb)	THRUST LOAD (lb)	DISTANCE BETWEEN BEARINGS (in)
1"	100	75	1.40
1 1/2"	300	200	2.15
2"	500	350	2.15
2 1/2"	900	600	2.50
3 1/4"	1300	900	3.75

Port and Cushion Locations

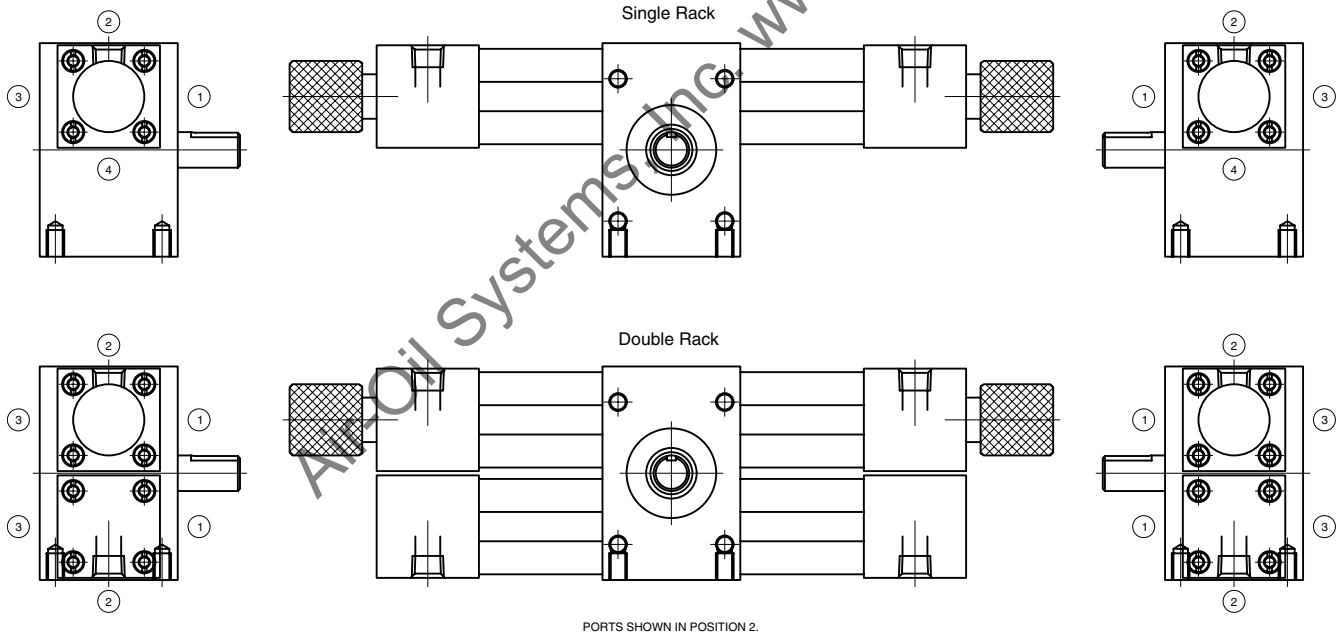

Standard port location is position 1. Standard cushion location is position 2. Ports and/or cushions in position 4 are only available on single rack rotary actuators.

BORE SIZE	PORT SIZE			
	1/8	1/4	3/8	1/2
1"	S	A	-	-
1 1/2"	A	S	A	-
2"	A	S	A	-
2 1/2"	A	S	A	-
3 1/4"	A	A	S	A

S=Standard
A=Available



Multi-position Rotary Actuator 3 Position

Our rotary actuators are available in various multi-position configurations. The following shows 3, 4 and 5 position types. Consult factory.

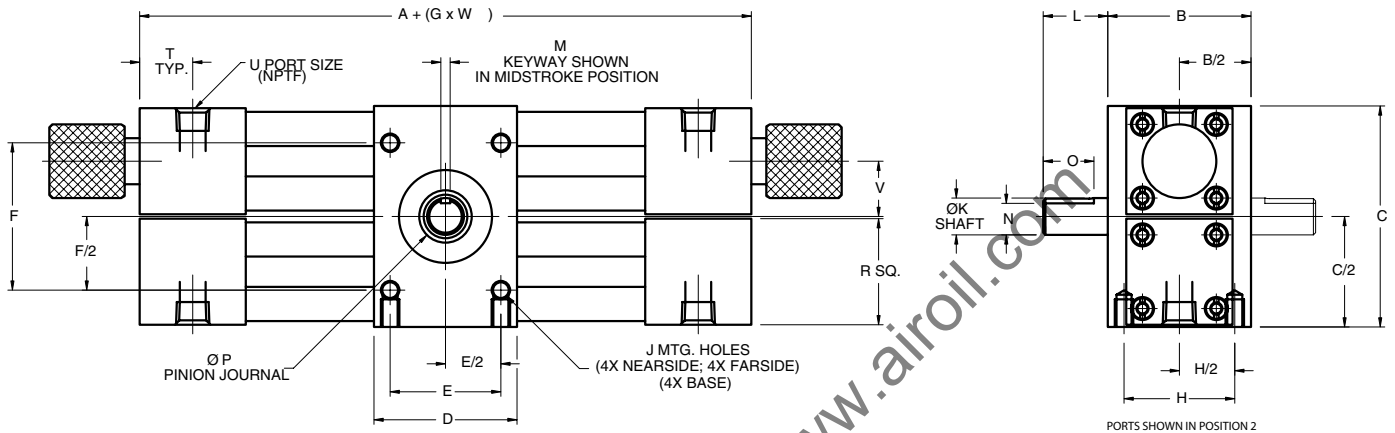

Dimensions

BORE	A	B	C	D	E	F	G	H	J	K	L	M	N	O	P	R	T	U	V
1"	7.50	2.00	3.00	2.00	1.50	2.00	0.01746	1.50	1/4-20 X 3/8 DEEP	.500/.499	0.88	.125/.127	.430/.425	0.63	0.59	1.44	0.75	1/8	0.75
1 1/2"	8.50	3.00	4.25	3.00	2.00	3.00	0.02328	2.00	5/16-18 X 1/2 DEEP	.875/.874	1.88	.188/.190	.771/.761	1.50	0.98	2.00	0.75	1/4	1.13
2"	9.50	3.00	5.00	4.00	2.50	3.50	0.03144	2.00	3/8-16 X 1/2 DEEP	1.125/1.124	1.88	.250/.252	.986/.976	1.50	1.18	2.44	0.75	1/4	1.25
2 1/2"	9.75	3.50	6.00	4.00	2.50	4.50	0.03926	2.00	1/2-13 X 3/4 DEEP	1.375/1.374	2.25	.313/.315	1.201/1.191	1.75	1.57	2.94	0.75	1/4	1.5
3 1/4"	11.25	5.00	8.00	5.00	3.00	5.00	0.04800	2.50	3/4-10 X 1 DEEP	1.750/1.749	3.50	.375/.377	1.542/1.532	3.00	1.77	3.75	0.88	3/8	1.94

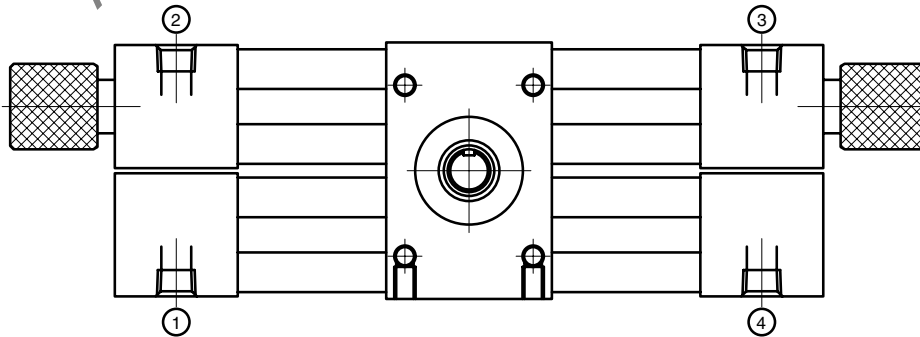

A three position rotary actuator provides one intermediate stopping position between the full counterclockwise and full clockwise position. The full counterclockwise position is achieved by pressurizing port 1. The intermediate position is achieved by pressurizing both ports 2 and 3. The final clockwise position is achieved by pressurizing port 4. Rotation adjustment for the full counterclockwise and full clockwise positions only are standard.



R Series Rotary Actuator

NUMATICS®

4 Position

W° = Full Rotation

X° = First Intermediate Rotation

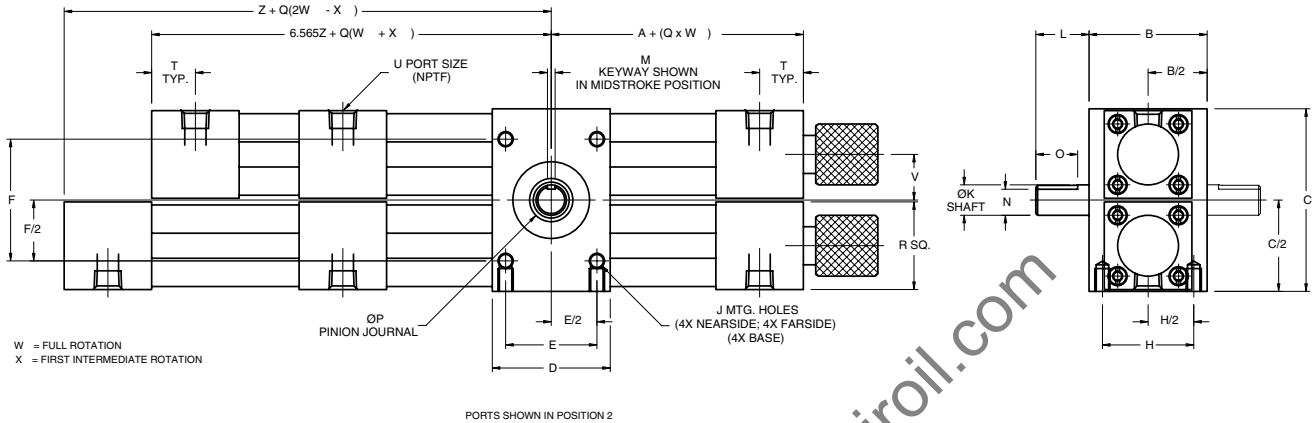

Dimensions

BORE	A	B	C	D	E	F	H	J	K	L
1"	3.75	2.00	3.00	2.00	1.50	2.00	1.50	1/4-20 X 3/8 DEEP	.500/.499	0.88
1 1/2"	4.25	3.00	4.25	3.00	2.00	3.00	2.00	5/16-18 X 1/2 DEEP	.875/.874	1.88
2"	4.75	3.00	5.00	4.00	2.50	3.50	2.00	3/8-16 X 1/2 DEEP	1.125/1.124	1.88
2 1/2"	4.88	3.50	6.00	4.00	2.50	4.50	2.00	1/2-13 X 3/4 DEEP	1.375/1.374	2.25
3 1/4"	5.63	5.00	8.00	5.00	3.00	5.00	2.50	3/4-10 X 1 DEEP	1.750/1.749	3.50

M	N	O	P	Q	R	T	U	V	Z
.125/.127	.430/.425	0.63	0.59	0.00872	1.44	0.75	1/8	0.75	6.405
.188/.190	.771/.761	1.50	0.98	0.01164	2.00	0.75	1/4	1.13	6.904
.250/.252	.986/.976	1.50	1.18	0.01571	2.44	0.75	1/4	1.25	7.407
.313/.315	1.201/1.191	1.75	1.57	0.01963	2.94	0.75	1/4	1.50	7.655
.375/.377	1.542/1.532	3.00	1.77	0.02400	3.75	0.88	3/8	1.94	8.660

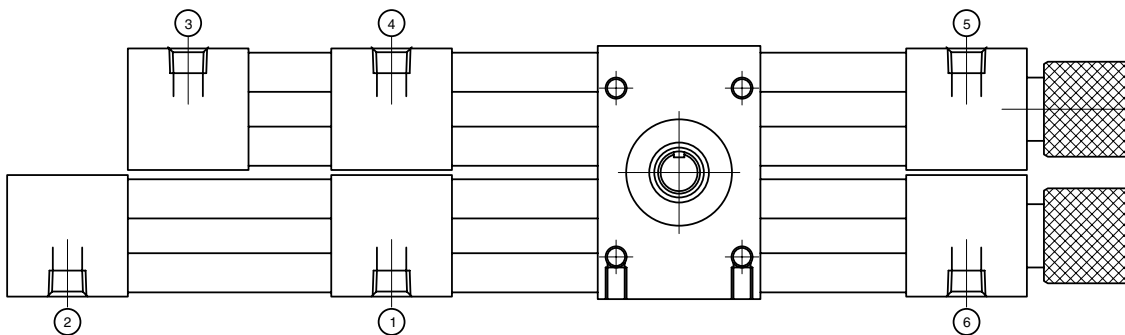

A four position rotary actuator provides two intermediate stopping positions between the full counterclockwise and full clockwise positions. The full counterclockwise position is achieved by pressurizing port 1. The first intermediate position is achieved by pressurizing both ports 2 and 3. The second intermediate position is achieved by pressurizing both ports 4 and 5. The final position is achieved by pressurizing port 6. Rotation adjustment for the full counterclockwise and full clockwise positions only are standard.



5 Position

W° = Full Rotation

X° = First Intermediate Rotation

Y° = Third Intermediate Rotation

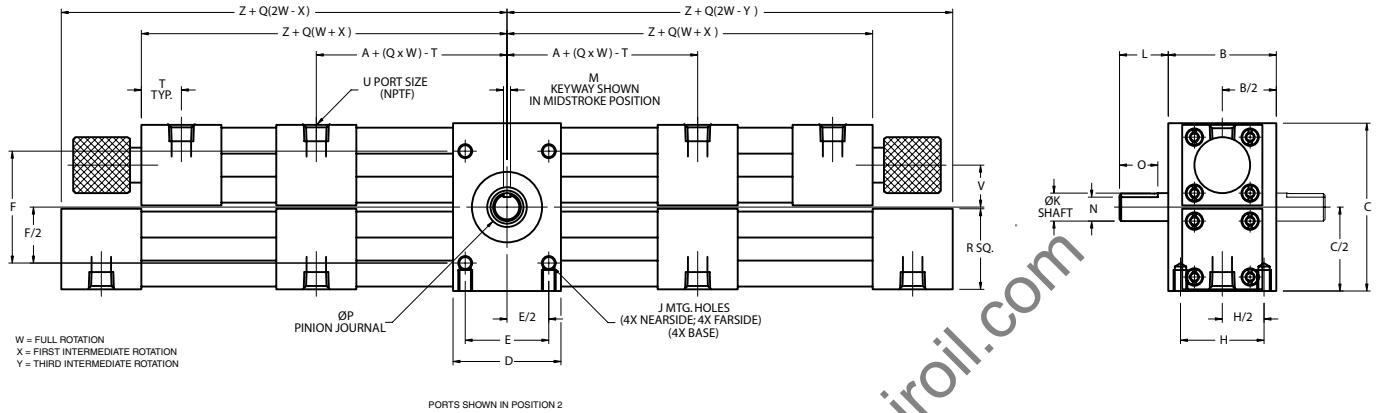

Dimensions

Bore	A	B	C	D	E	F	H	J	K	L
1"	3.75	2.00	3.00	2.00	1.50	2.00	1.50	1/4-20 X 3/8 DEEP	.500/.499	0.88
1 1/2"	4.25	3.00	4.25	3.00	2.00	3.00	2.00	5/16-18 X 1/2 DEEP	.875/.874	1.88
2"	4.75	3.00	5.00	4.00	2.50	3.50	2.00	3/8-16 X 1/2 DEEP	1.125/1.124	1.88
2 1/2"	4.88	3.50	6.00	4.00	2.50	4.50	2.00	1/2-13 X 3/4 DEEP	1.375/1.374	2.25
3 1/4"	5.63	5.00	8.00	5.00	3.00	5.00	2.50	3/4-10 X 1 DEEP	1.750/1.749	3.50

M	N	O	P	Q	R	T	U	V	Z
.125/.127	.430/.425	0.63	0.59	0.00872	1.44	0.75	1/8	0.75	6.405
.188/.190	.771/.761	1.50	0.98	0.01164	2.00	0.75	1/4	1.13	6.904
.250/.252	.986/.976	1.50	1.18	0.01571	2.44	0.75	1/4	1.25	7.407
.313/.315	1.201/1.191	1.75	1.57	0.01963	2.94	0.75	1/4	1.50	7.655
.375/.377	1.542/1.532	3.00	1.77	0.02400	3.75	0.88	3/8	1.94	8.660

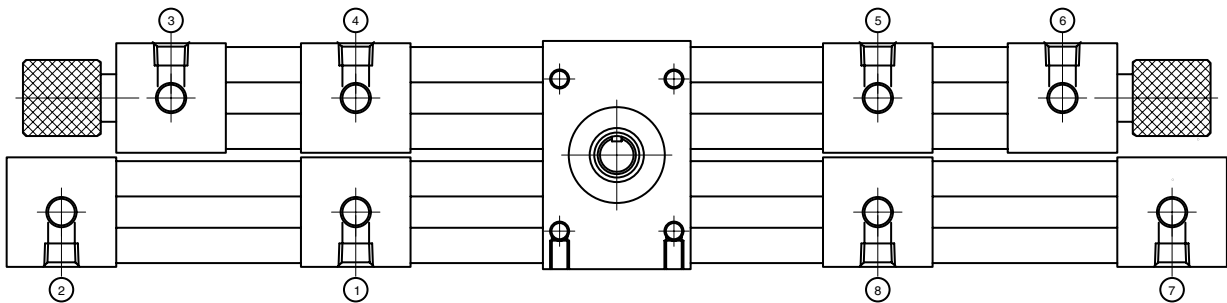

A five position rotary actuator provides three intermediate stopping positions between the full counterclockwise and full clockwise positions. The full counterclockwise position is achieved by pressurizing port 1. The first intermediate position is achieved by pressurizing both ports 2 and 3. The second intermediate position is achieved by pressurizing both ports 4 and 5. The third intermediate position is achieved by pressurizing both ports 6 and 7. The final clockwise position is achieved by pressurizing port 8. Rotation adjustment for the full counterclockwise and full clockwise positions only are standard.



R Series Rotary Actuator

NUMATICS®

R series Switches

R series Global Switch

			Switches					
Cylinders	Bore		RSS02	RSQ02	HPNPS31	HPNPQ31	HNPNS32	HNPNQ32
R series	All	Bracket	Direct Fit w/included adapter	Direct Fit w/included adapter	Direct Fit w/included adapter	Direct Fit w/included adapter	Direct Fit w/included adapter	Direct Fit w/included adapter

R series World Switch

			Switches					
Cylinders	Bore		SR6-002	SR6-022	SH6-021	SH6-031	SH6-022	SH6-032
R series	All	Bracket	Direct Fit	Direct Fit	Direct Fit	Direct Fit	Direct Fit	Direct Fit

NOTE: See page 17 for dimensional and technical data

Air-Oil Systems, Inc. www.airoil.com



R series Global Switches

Reed Switch (AC/DC NO), flying lead - RSS02, 8mm connector - RSQ02

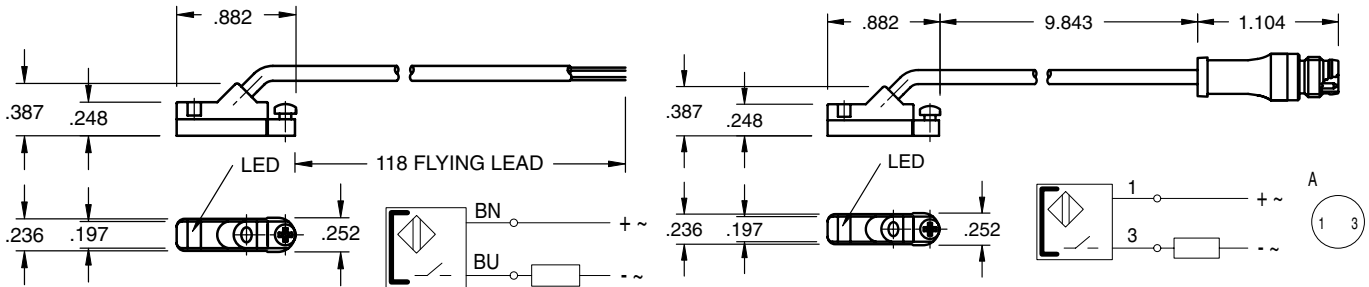

Sensing Data

Ambient temperature range T_a	(°F/°C)	-4 to 176 (-20 to 80)
Frequency of operating cycles f at U_e	(kHz)	0.5
Turn on time t	(ms)	≤ 0.25
Turn off time t	(ms)	0.03
LED function indication		yes

Electrical Data

Rated operational voltage U_e	(V)	3...130 AC/DC
Supply voltage U_B	(V)	3...130 AC/DC
Voltage drop U_d at I_e Stat./dyn.	(V)	3.5
Rated insulation voltage U_i	(V)	2750 DC (EN 60335-1)
Rated supply frequency	(Hz)	AC/DC
Rated operational current I_e	(mA)	50 (10W max.)
No-load supply current I_o at U_e d./und.	(mA)	0

Observe polarity for correct LED function

Mechanical Data

Housing material	Polyamide
Material of sensing face	Polyamide
Connection	PVC cable
Degree of Protection	IP 67
Rated shock: half-sinus	50g, 11 ms
Rated vibration environment	10g, 10...2000 Hz, 90 min



Electronic Switch (PNP NO), flying lead - HPNPS31, 8mm connector - HPNPQ31

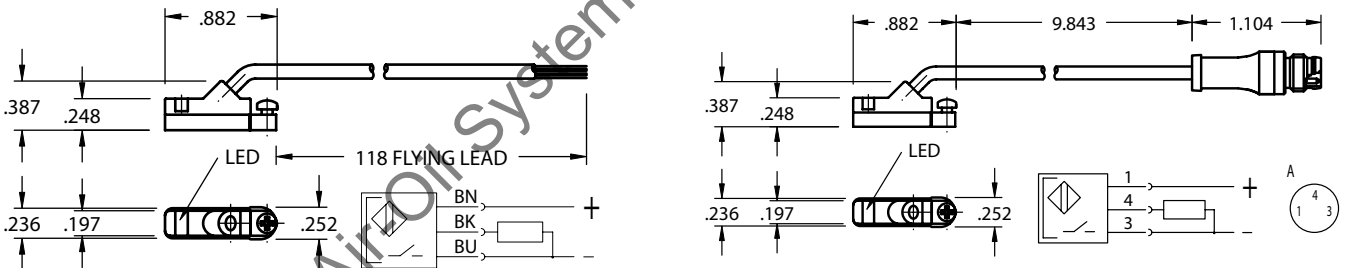

Sensing Data

Ambient temperature range Δ	(°F/°C)	-13 to +158 (-25 to +70)
Temperature drift	(% of)	$\leq 0.3\%/^{\circ}\text{C}$
Frequency of operating cycles f at U_e	(kHz)	10
Turn on time t	(ms)	.05
Turn off time t	(ms)	.05
Utilization categories		DC13
Function-/supply voltage indication		YES

Electrical Data

Rated operational voltage U_e	(V)	24 DC
Supply voltage U_B	(V)	10...30 DC
incl. ripple	(% of U_e)	15
Voltage drop U_d at I_e Stat./dyn.	(V)	1/-
Rated insulation voltage U_i	(V)	75 AC
Rated supply frequency	(Hz)	DC
Rated operational current I_e	(mA)	200
No-load supply current I_o at U_e d./und.	(mA)	25/13
Protected against polarity reversal		YES

Mechanical Data

Housing material	Polyamide
Material of sensing face	Polyamide
Connection	PVC cable
Degree of Protection	IP 67
Rated shock: half-sinus	30 g, 11 ms
Rated vibration environment	55 Hz, 1mm amplitude, 3 x 30





R Series Rotary Actuator

NUMATICS®

Electronic Switch (NPN NO), flying lead - HNPNS32, 8mm connector - HNPNQ32

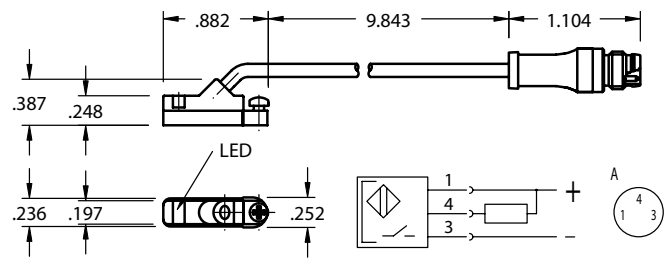
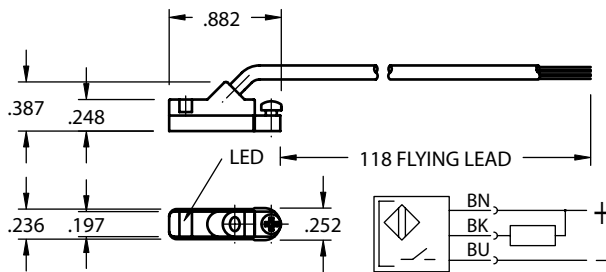

Sensing Data

Ambient temperature range Δ	(°F/°C)	-13 to +158 (-25 to +70)
Temperature drift	(% of S_r)	$\leq 0.3\%/^{\circ}\text{C}$
Frequency of operating cycles f at U_e	(kHz)	10
Turn on time t	(ms)	.05
Turn off time t	(ms)	.05
Utilization categories		DC13
Function-/supply voltage indication		YES

Electrical Data

Rated operational voltage U_e	(V)	24 DC
Supply voltage U_B	(V)	10...30 DC
incl. ripple	(% of U_e)	15
Voltage drop U_d at I_e Stat./dyn.	(V)	1/-
Rated insulation voltage U_i	(V)	75 AC
Rated supply frequency	(Hz)	DC
Rated operational current I_e	(mA)	200
No-load supply current I_o at U_e d./und.	(mA)	25/13
Protected against polarity reversal		YES

Mechanical Data

Housing material	Polyamide
Material of sensing face	Polyamide
Connection	PVC cable
Degree of Protection	IP 67
Rated shock: half-sinus, 30 g, 11 ms	
Rated vibration environment: 55 Hz, 1mm amplitude, 3 x 30	



R series Global application Detail

Profile Tube Detail

1. Global Switch
2. Included Dovetail adapter
3. Dove Tail extrusion

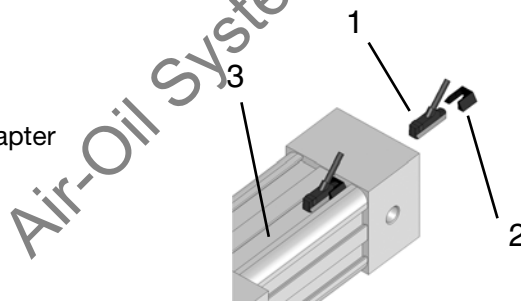



R Series World Switches

Reed Switch - Normally Open Type SR6

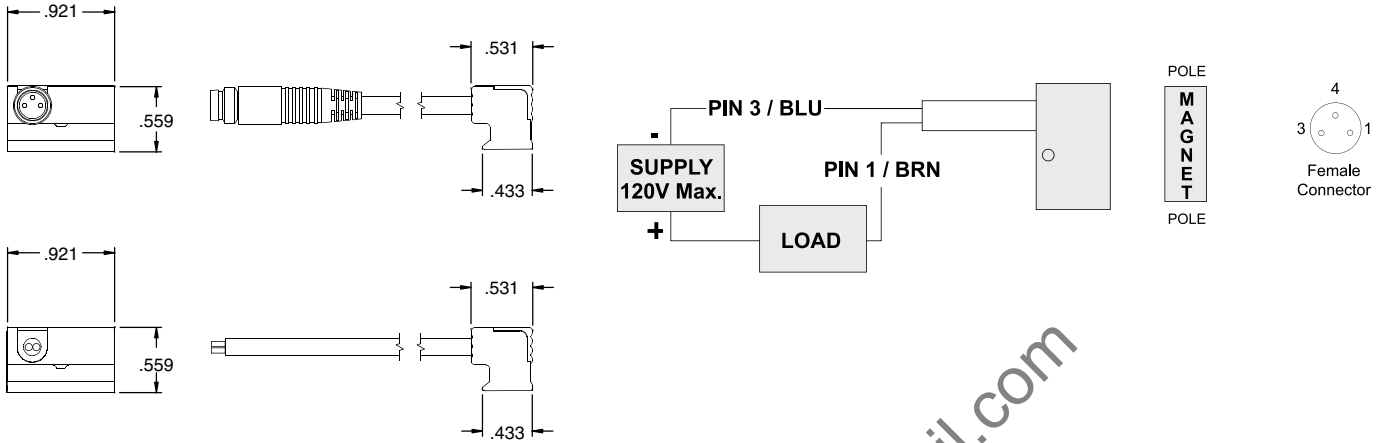

P/N	Switch Style	Switch Type	Function	Switching Voltage	Switching Current	Switching Power	Voltage Drop
SR6-002	3m Wire Version	Reed Switch, LED	SPST Normally Open	5 -120V AC/DC	0.025 Amps Max. 0.001 Amps Min.	3 Watts Max.	3.5 Volts
SR6-004	3m Wire Version	Reed Switch, LED & MOV	SPST Normally Open	5 -120V AC/DC	0.5 Amps Max. 0.005 Amps Min.	10 Watts Max.	3.0 Volts
SR6-021	8mm Pigtail	Reed Switch	SPST Normally Open	0 -120V AC/DC	0.5 Amps Max.	10 Watts Max.	0 Volts
SR6-022	8mm Pigtail	Reed Switch, LED	SPST Normally Open	5 -120V AC/DC	0.025 Amps Max. 0.001 Amps Min.	3 Watts Max.	3.5 Volts
SR6-024	8mm Pigtail	Reed Switch, LED & MOV	SPST Normally Open	5 -120V AC/DC	0.5 Amps Max. 0.005 Amps Min.	10 Watts Max.	3.0 Volts

Hall Effect Switch - Sourcing Type SH6

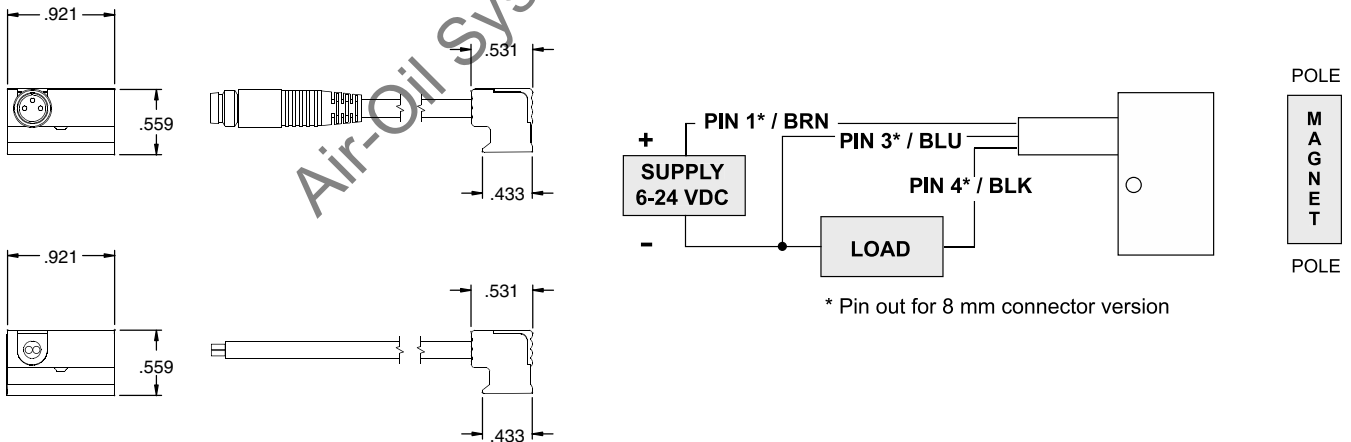

P/N	Switch Style	Switch Type	Function	Switching Voltage	Switching Current	Switching Power	Voltage Drop
SH6-031	3m Wire Version	Hall Effect for Reed Magnet & Light Sourcing	Normally Open Sourcing (PNP)	6 -24 VDC	0.3 Amps Max.	7.2 Watts Max.	0.5 Volts
SH6-021	8m Connector Pigtail	Hall Effect for Reed Magnet & Light Sourcing	Normally Open Sourcing (PNP)	6 -24 VDC	0.3 Amps Max.	7.2 Watts Max.	0.5 Volts



R Series Rotary Actuator

NUMATICS®

Hall Effect Switch - Sinking Type SH6

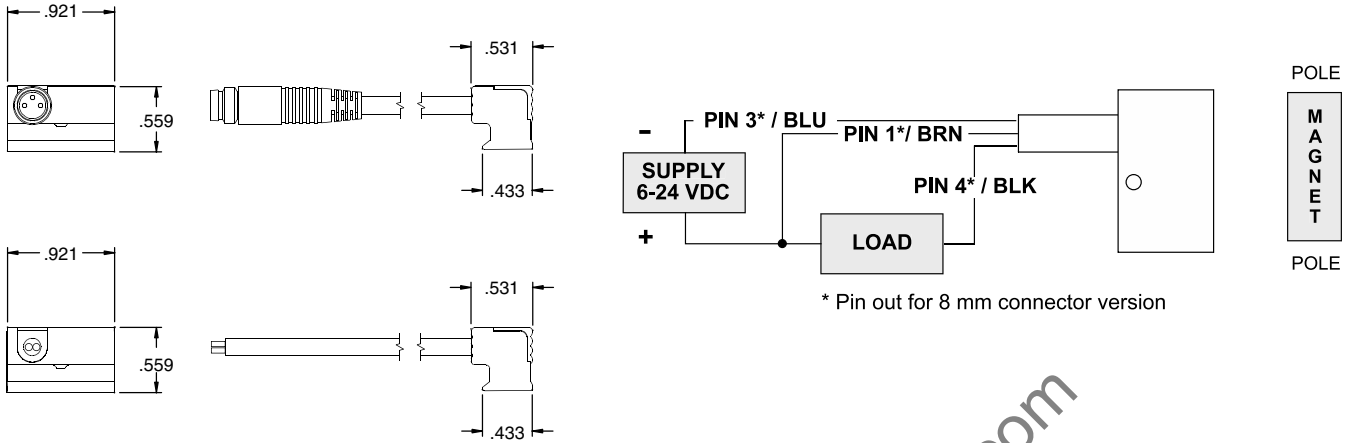

P/N	Switch Style	Switch Type	Function	Switching Voltage	Switching Current	Switching Power	Voltage Drop
SH6-032	3m Wire Version	Hall Effect for Reed Magnet & Light Sourcing	Normally Open Sourcing (NPN)	6 -24 VDC	0.3 Amps Max.	7.2 Watts Max.	0.5 Volts
SH6-022	8m Connector Pigtail	Hall Effect for Reed Magnet & Light Sourcing	Normally Open Sourcing (NPN)	6 -24 VDC	0.3 Amps Max.	7.2 Watts Max.	0.5 Volts

R series World application Detail

Profile Tube Detail

1. World Switch
2. Dove Tail extrusion

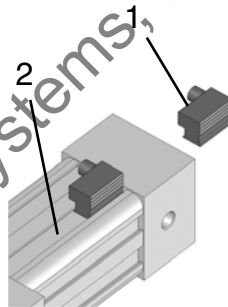

NUMATICS®

World Class Supplier
of Pneumatic Components



World Headquarters

Numatics Incorporated

Phone: 248-887-4111
Fax: 248-887-9190

UNITED STATES

Numatics – Air Preparation

Phone: 810-667-3900
Fax: 810-667-3902

Numatics – Valves

Phone: 248-887-4111
Fax: 248-887-9190

Numatics – Miniature Valves

Phone: 248-960-1400
Fax: 248-960-2160

Numatics – Cylinders

Phone: 615-771-1200
Fax: 615-771-1201

Numatics – Rodless Cylinders

Phone: 519-452-1777
Fax: 519-452-3995

Numatics – Automation

Phone: 440-934-3200
Fax: 440-934-2288

CANADA

Ontario

Numatics, Ltd.
Phone: 519-452-1777
Fax: 519-452-3995

Quebec

Numatics, Ltd.
Phone: 514-332-6444
Fax: 514-332-9273

British Columbia

Numatics, Ltd.
Phone: 604-574-0401
Fax: 604-574-3713

EUROPE

Germany – European Headquarters

Numatics GmbH
Phone: 011-49-22 41-31 60-0
Fax: 011-49-22 41-31 60 40

Hungary

Numatics Kft.
Phone: 011-36-13 82 21 35
Fax: 011-36-12 04 39 47

EUROPE

England

Numatics Limited
Phone: 011-44-1525-37 07 35
Fax: 011-44-1525-38 25 67

France

Numatics s.a.r.l.
Phone: 011-33-1 41 21 48 88
Fax: 011-33-1 41 21 48 89

Italy

Numatics srl
Phone: 011-39-030-373 19 99
Fax: 011-39-030-373 19 81

Netherlands

Numatics B.V.
Phone: 011-31-418-65 29 50
Fax: 011-31-418-65 29 43

Spain

Numatics Spain S.L.
Phone: 011-34-93-221 21 96
Fax: 011-34-93-221 35 14

AFRICA

South Africa

Numatics SA (Pty) Ltd.
Phone: 011-27-11-8 65 44 52
Fax: 011-27-11-8 65 42 90

LATIN & SOUTH AMERICA

Mexico

Numatics de Mexico S.A. de C.V.
Phone: 011-52-222-284 6176
Fax: 011-52-222-284 6179

Brazil

Valvair Comercial Ltda.
Phone: 011-55-12-351 2874
Fax: 011-55-12-351 1958

ASIA & PACIFIC

Australia

Numatics Australia Pty. Ltd.
Phone: 011-61-3-95 63 86 00
Fax: 011-61-3-95 63 85 11

Taiwan – Asian Headquarters

Numatics Co, Ltd. Asia
Phone: 011-886-2-29 15 16 05
Fax: 011-886-2-29 14 18 97

For a comprehensive listing of all Numatics production and distribution facilities worldwide, visit www.numatics.com