

# How to select the best linear actuator type for valve automation in process industries

## *A comparison of conventional and emerging technologies for valve actuation and automation*

By Ryan Klemetson, Target Markets Manager  
Tolomatic, Inc.

### About the Author



Ryan Klemetson is a Target Markets Manager at Tolomatic. Ryan has worked on multiple custom actuator design projects in a wide variety of industries from Oil & Gas, Medical, Commercial, and Industrial Printing applications. Prior to joining Tolomatic, Ryan spent 5 years in the mobile hydraulics industry. He obtained an AAS Degree in Manufacturing Engineering from Alexandria Technical College, Alexandria, MN.

Tolomatic is a leading supplier of linear actuators, both electric and pneumatically driven. Tolomatic's expertise includes linear actuators, servo-driven high-thrust actuators, servo and stepper motors, drives, and configured linear systems. Standard products are built to order and shipped with industry leading delivery schedules. Tolomatic also manufactures right-angle gear drives, caliper disc brakes, and clutches.

### Introduction

With the ongoing need to improve productivity, increase efficiency and minimize down time in the process control industry, some valve automation applications require increasingly sophisticated motion control solutions. To meet these needs, engineers can select from a variety of valve automation options, depending on the valve type, industry and required function. This paper compares an emerging technology in valve actuation—brushless servo motor-driven valve actuators—with traditional methods, including pneumatic-actuated systems, hydraulic-actuated systems and electric valve actuators driven by conventional brush motors.

Broadly speaking, control valves operate in two different ways: linear motion (rising stem) or rotary motion (half turn or quarter turn). Each method is designed for specific functions and applications. This paper focuses on rising stem valves—typically used in mission critical areas of a process where reliability, repeatability, accuracy and responsiveness are all desired characteristics—and explores how brushless servo motion control can provide performance improvements beyond traditional actuation methods.

### Pneumatic actuation

Pneumatic-actuated systems have been a primary technology for valve operation for many years. They are simple, low-cost and easy to maintain. By design, pneumatic operation does not create a spark and is often specified for hazardous applications. Compressed air is also readily available in many manufacturing and process control environments.

Pneumatic-actuated systems, however, have some limitations. Generally, a valve requires more shift force in a static state than when it is in motion. This trait is commonly referred to as “stick slip.” To overcome stick slip,

pneumatic-actuated systems build up excess pressure, which can create a rapid movement once the valve is in motion. The resulting overshoot can delay settling on the specified set point or make it difficult to achieve set point at all.

A valve requires more shift force in a static state than when it is in motion. This trait is commonly referred to as stick slip.

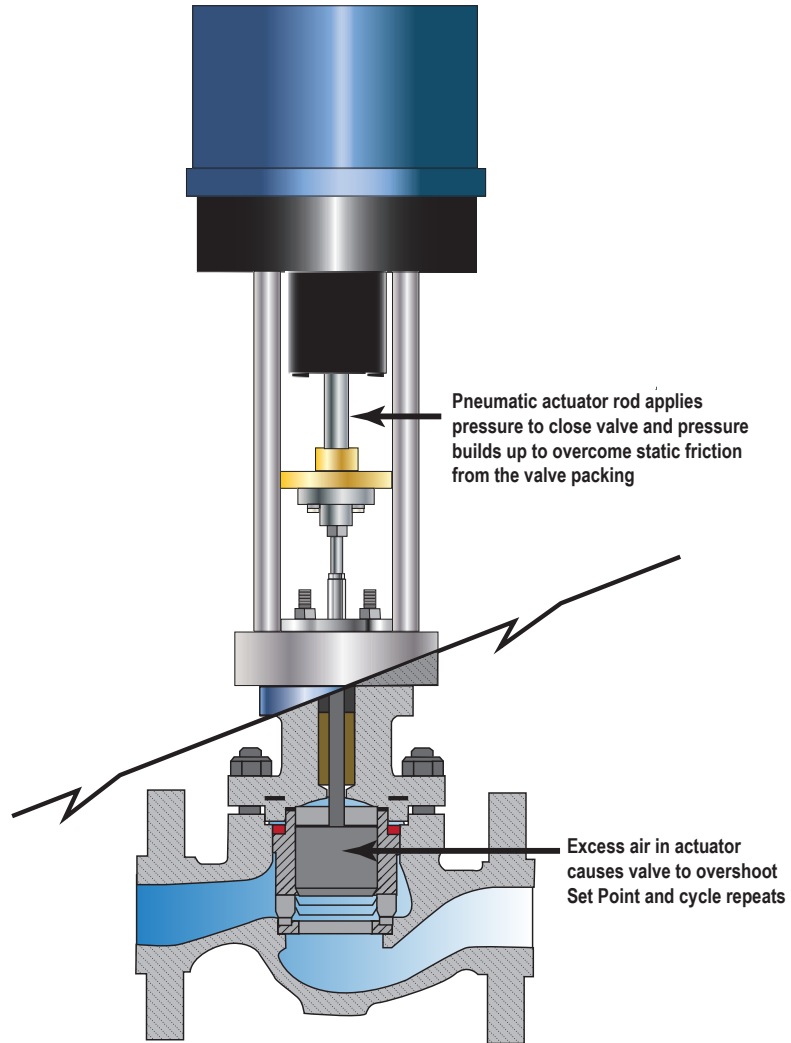
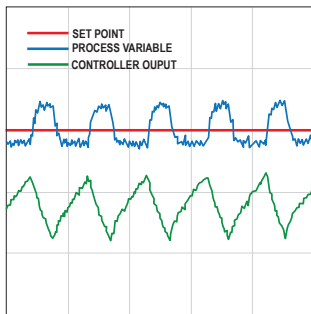

***Pneumatic slip stick is caused from excess air build up in the actuator to compensate for encountered static friction from valve packing materials and components and causes the valve to overshoot the set point resulting in fluctuating valve performance.***

In addition to stick slip, other common problems that can negatively affect pneumatic actuated systems include:

- **System demand**—Where there are large numbers of control valves or varying degrees of system demand, the available air pressure and air flow may be limited, reducing speed and response time.
- **Air quality**—Conditioning and air quality can cause components such as cylinders to operate below their peak performance and efficiency, which can lead to premature component failure.
- **Ambient air temperature**—Where climate temperatures are not

controlled, freezing temperatures can cause control valves, actuators, air lines and controllers to seize. The presence of ice due to freezing moisture in the system in some or all of these components could incapacitate an entire control system. Poor air quality and system demand will still affect overall performance regardless of the climate.

These conditions, in conjunction with operating in an outdoor environment, can further impact system performance due to extreme cold temperatures.

### Cost of operation

Another challenge with pneumatic actuation is the recent shift in some industries to focus on the cost of operating a pneumatic-actuated system compared to buying and installing the system (cost of ownership vs. cost of acquisition). It is widely accepted that pneumatic-actuated systems have operating efficiencies between 10 and 30 percent. Leaks and pressure losses through hoses, fittings, poorly maintained valves and air preparation components, as well as improper settings, all contribute to the overall inefficiencies of pneumatic-actuated systems.

*High operating costs associated with keeping pneumatic systems operating at their peak efficiency has led some engineers to weigh cost of operation as more important than the cost of acquisition for some processes.*

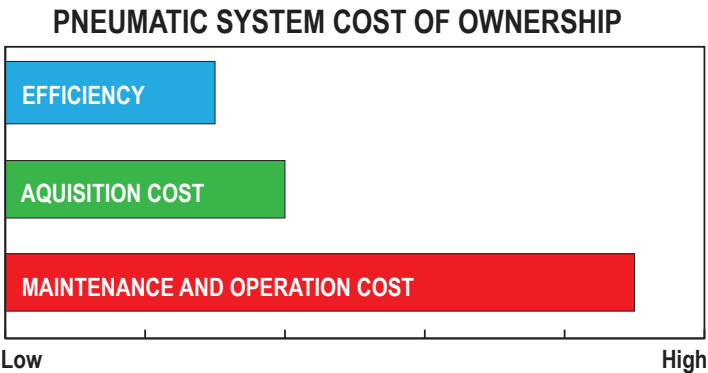

*Pneumatic systems can have a low cost of acquisition but to keep them running at their peak efficiency requires constant maintenance checks, repairs and replacement components. All these factors combine to deliver a total cost of system ownership.*

Sustaining even these low operating efficiencies can require continual maintenance, which also adds to the total cost of operation. This high operating cost, coupled with the need for increased precision and reliability in valve operation, has led some engineers to weigh cost of operation as more important than the cost of acquisition for some processes.

### Hydraulic actuation

By comparison, some research suggests that hydraulic-actuated systems are in fact the most expensive to operate because they require continuous power to maintain pressure. However, there are compelling reasons why hydraulic-

actuated systems continue to be deployed for valve automation processes:

- Hydraulic-actuated systems can be designed as self-contained systems, allowing them to be deployed in remote locations.
- The cost of acquisition can be low to moderate, depending on the size and sophistication of the system.
- As with pneumatic-actuated systems, hydraulic-actuated systems do not require significant technical ability to install, configure and deploy.
- Hydraulic cylinders have a very high power density.
- The oil used in these systems is nearly incompressible, so overall stiffness, positional repeatability and accuracy are improved over pneumatic-actuated systems.

***In hydraulic applications, fluctuations in temperatures can reduce system efficiency due to variations in oil viscosity.***

At the same time, environmental and system contamination can still negatively affect overall performance in many of the same ways a pneumatic-actuated system would be affected. Oil leaking from a system will also diminish performance over time. If the level gets low enough, a leak can create a risk of component damage. Substantial leaks can be considered an environmental hazard. As with pneumatic-actuated systems, hydraulic-actuated systems also require a high degree of maintenance to ensure proper performance.

Another notable difference between hydraulic- and pneumatic-actuated systems is the effect of ambient air temperature on efficiency due to variations in hydraulic oil viscosity. In the case of AW32 hydraulic oil, viscosity increases or decreases with extremes in air temperature. At -20°F (-29°C) its viscosity is very high which makes the oil harder to push. As temperatures increase beyond room temperature, oil will start to lose viscosity and become very thin. As a result, oil can flow through smaller openings, requiring more flow and thus more power. Oil heaters or heat exchangers are used to regulate oil temperatures based on where the system is deployed, but can increase component cost, system complexity and cost of operation.

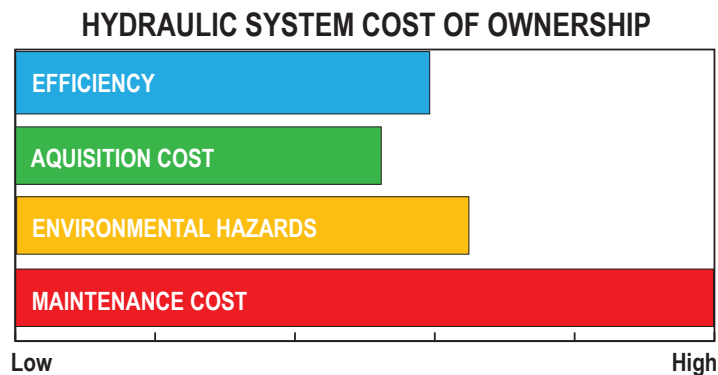

***Hydraulic systems can be higher to operate because of the continual power required to maintain pressure. They also require high levels of maintenance and are subject to performance issues when fluctuating temperatures affect oil viscosity.***

*In hydraulic and pneumatic valve control, latency due to actuators and control circuits operating below their peak designed efficiency can decrease overall performance in a process control environment.*

In both hydraulic and pneumatic valve control, latency due to actuators and control circuits operating below their peak designed efficiency can decrease overall performance in a process control environment. Both pneumatic- and hydraulic-actuated systems require continual maintenance to assure optimal performance and efficiency, and to avoid unexpected component failures. The costs associated with maintaining these systems should always be considered when evaluating true system cost. Systems installed in remote locations or in hazardous environments may receive little or no maintenance until a component fails, which can often cause a shutdown. The cost of unexpected down time due to component failure can be exponential compared to the cost of replacement components or deploying an alternate technology in the same application.

### **Electric actuation with conventional brush motors**

*Electric valve systems with brush motors can offer a significant improvement over traditional fluid driven systems.*

Electric valve actuators, which use a conventional brush motor to power the actuator, offer a cost-effective alternative to pneumatic- or hydraulic-actuated systems for valve actuation. Because they require fewer components—there is no need for a filter, regulator, air lines, flow controls, control valves, and other associated components such as hoses, fittings and gages—all-electric systems require minimal maintenance. Overall, brush motors offer an inexpensive means of achieving the increased performance, reliability and safety required in many process environments. As a result, they are widely used on valve actuators in the process industry. Electric actuation with brush motor technology has been time-tested in the field and considered by some to be the de facto standard. Electric-actuated valves can have very good resolution (<0.1% of span) when used with mechanical gear reducers to increase force. However, the resulting high reduction ratios caused by these devices also limit the actuator's ability to close a valve quickly.

Even with these limitations, electric valve systems with brush motors can offer a significant improvement over traditional fluid driven systems. What makes conventional brush motors in electric actuators a cost-effective solution is also the source of their limitations. As the name implies, these motors have physical brushes which contact a commutator and armature. Frequent cycling of power to start motion (for instance, in a modulating application) exposes the brushes to inrush current repeatedly and can cause the motor to wear out quickly. Because of this, typical duty-cycle ratings for actuators that use brush motors are measured in starts and stops per hour. It is not uncommon to see these actuators with a duty cycle limited to a given number of starts and stops per hour, whereas a servo can be operated continuously with no restrictions when appropriately sized for the given application.

In addition to worn or damaged brushes, this style of motor is also susceptible to poor performance due to:

- Arcing between the brushes and commutator
- Brush holders not being equally spaced
- Brushes too far from commutator surface
- Current overloads and underloads
- Improper spring pressure on the brushes
- Foreign material on commutator surface

### ELECTRIC WITH BRUSH MOTORS COST OF OWNERSHIP

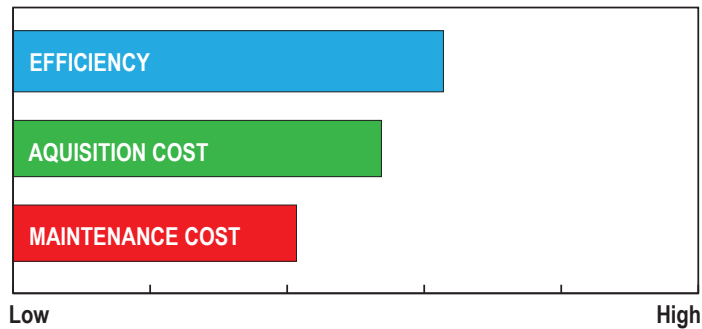

*Brush wear in brush motors requires them to be used in low duty-cycle applications and also requires frequent replacement of brushes. They are however a low-cost electric solution with less components than pneumatic or hydraulic and are relatively simple to integrate into electrical systems.*

*Servo valve actuation costs more than conventional brush motors but they are becoming more prominent in the process control industries because of their proven reliability and increased performance capabilities.*

These systems are relatively simple to integrate into most control schemes. Field bus communication protocols such as HART are available as a standard feature or option. Bluetooth, along with infrared capabilities, are also available on some systems to allow for wireless set-up and communication. This is beneficial to actuators operating in remote or harsh environments. Diagnostics, programmability, safety limits and data logging capabilities have also become available as part of an electric system.

### Electric actuation with brushless servo motors

Many of the challenges and limitations using brush motors are typically not found when using brushless servo technology. Brushless servo motors have long been used for industrial automation processes and have proven to be a very reliable and robust means of controlling linear actuators. They cost more than conventional brush motors typically used with electric valve actuators, but brushless servo motors are becoming more prominent in process control industries because of their proven reliability and increased performance capabilities.

As the name implies, brushless servo motors do not operate in the same manner as brush motors. Unlike brush motors that pass current through an

armature, brushless servo motors use a permanent magnetic rotor and a wound stator. Power is passed through the wound stator which creates an electric field in the phases of the motor. The magnetic poles of the rotor react to this electric field which creates rotary motion. Since no physical brushes come into contact within the motor, mechanical or electrical breakdowns are rare. Instead, external elements or damage from impact or improper use are more likely to cause this type of motor to fail.

Brushless servo motors must have some form of continuous position feedback from the rotor to maintain proper phasing and function. This is typically provided by virtue of an integrated feedback device such as a digital incremental encoder, multi-turn absolute encoder, or resolver. Although this form of feedback adds complexity, it is also the component that communicates position to the controller, which in turn achieves high resolution, accuracy and repeatability.

***Using a rotary servo motor to create linear movements with a ball or roller screw driven actuator provide motion system efficiencies of approximately 75 to 80 percent—much higher than pneumatic-actuated or hydraulic-actuated systems.***

This increased complexity also requires a more sophisticated means of control. However, this more sophisticated control, in conjunction with the feedback device, provides increased performance over conventional brush motors. Position, speed and torque can be precisely controlled and continuously monitored. These abilities allow brushless servo motors to automatically compensate for varying conditions exerted upon the mechanical end-effector attached to the stem. Using a rotary servo to create this linear movement with mechanical components such as a rack and pinion, planetary gear sets or more complex assemblies like a linear ball or roller screw driven actuator provides motion system efficiencies of approximately 75 to 80 percent—much higher than pneumatic-actuated or hydraulic-actuated systems.

Some of the more notable performance benefits of brushless servo motors are:

- 100% duty-cycle rated
- Significant increase in efficiency
- Designs available to operate in extreme temperatures and environments
- Improved positional repeatability and accuracy over brush motors
- Ability to compensate for increased resistance or changes in external forces
- Dynamic performance/quick response
- Reduced or no maintenance
- Condensed installation times

## ELECTRIC WITH SERVO MOTORS COST OF OWNERSHIP

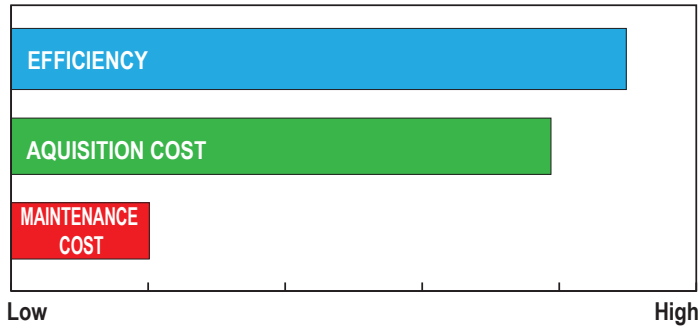

*The only real downside to servo systems is that they have a higher purchase price than electric valve actuators with conventional brush motors.*

*Unlike brush motors, servo motors have no brushes to wear and can operate at 100% duty cycle with little to no maintenance. They offer closed loop feedback with high resolution, accuracy, repeatability and precise control. Although they have a higher acquisition cost, they provide the best performance and quick response times, crucial in many valve applications.*

Brushless servo motors can operate more smoothly and at greater speeds (6,000+ RPM) than other motor types used on valve actuators. Monitoring speed and torque through the controller enables brushless servo motors to compensate for increased force requirements (stick slip, pressure surge, contamination or blockage in a valve) and complete a move without sacrificing speed. This capability enables servo systems to execute push-to-force moves (full seat), or maintain a position within a dynamic circuit (burps or pressure spikes). The only real down side to servo systems is that they have a higher purchase price than electric valve actuators with conventional brush motors.

### Summary

Electric linear valve actuators (both brush motor and brushless servo motor types) provide superior control in valve applications. Electric actuator technology has evolved, bringing costs down, reducing the number of components, making set-up user friendly, and dramatically improving overall system efficiencies when compared to pneumatic- and hydraulic-actuated systems. Brushless servos are reliable and maintain a high level of performance in extreme temperatures and harsh environments. Though still highly effective and widely used, hydraulic- and pneumatic-actuated systems may have difficulties maintaining optimum performance levels in these same environments.

Cost, Maintenance and Performance Comparisons of Valve Actuator Technologies				
Actuator Technology	Acquisition Cost	Maintenance	System Rigidity	Repeatability
Electric / Servo motor	High	Low	Very high	Very high
Electric / Brush motor	Moderate to high	Low to moderate	Moderate to high	Moderate to high
Hydraulic	Moderate to high	Moderate to high	Moderate to high	Moderate
Pneumatic	Low	High	Low	Low



Even with all the benefits and advantages that brushless servo technology offers, pneumatic-actuated systems, hydraulic-actuated systems and electric-actuated systems utilizing conventional brush motor technology are still the appropriate solution for many valve applications. With the cost going down and reliability going up for brushless servo systems, there are now more choices than ever for optimizing existing processes, choices that can improve performance and reduce maintenance while lowering the cost of operation and improving overall system performance.