

# STC Valves & Pneumatic Components

Push-In Fittings

Filter-Regulator-Lubricator

Solenoid & Air Pilot Valves

Process Valves

Manual Air Valves

Air Cylinders



Fine Quality

Precision Engineered

Advanced Design

Excellent Prices

STC™



connects fluid power to industrial automation™

Website: StcValve.com

# Table of Contents

<p><b>Section A</b></p>	<p><b>Composite Push-in Air Fittings</b></p> <p><b>Stainless Steel &amp; Brass Push-in Fittings</b></p>	
<p><b>Section B</b></p>	<p><b>Air Filter-Regulator-Lubricator</b></p>	
<p><b>Section C</b></p>	<p><b>Directional Air Solenoid &amp; Air Valves</b></p>	<p><b>Pilot</b></p>
<p><b>Section D</b></p>	<p><b>Process Solenoid Valves</b></p>	
<p><b>Section E</b></p>	<p><b>Manual Air Valves</b></p>	
<p><b>Section F</b></p>	<p><b>Air Cylinders</b></p>	

# Push-In Fittings



Fine Quality



Excellent Prices

Precision Engineered

Advanced Design



## Contents

STC Fittings Numbering System.....	A2
STC Composite Push-In Air Fittings List Price.....	A3-5
STC Miniature Composite Push-In Air Fittings List Price.....	A6
STC Polyurethane Air Tubing List Price.....	A6
STC Stainless Steel Push-In Fittings List Price.....	A7
STC Nickel-Plated Brass Push-In Fittings List Price.....	A8
Composite, Stainless Steel, & Nickel-Plated Brass Push-In Fittings Specifications.....	A9
STC Push-In Fittings Dimensions.....	A10-17
STC Composite Angle Flow Control Air Valves Flow Rate.....	A18

## STC Fittings Numbering System

Ordering Part No. =  
(eg. BC 1/8 10-32)

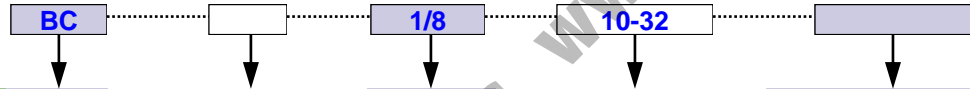







Fitting Name	Model	Material/Type	Tube OD	Thread Size / Stem/Tube	Options
AIR INLINE FLOW CONTROL	AS				
AIR FLOW CONTROL (panel mount)	ASC				
BRANCH TEE	BT				
BRASS MUFFLER	BSL				
BRASS SPEED CONTROL MUFFLER	BESL				
BULKHEAD CONNECTOR	BC				
BULKHEAD UNION	BU				
CHECK VALVE	KV				
COMPACT MALE CONNECTOR	CC				
CONTROL VALVE (meter-in)	CI				
CONTROL VALVE (meter-out)	CV				
CROSS UNION	CU				
ELBOW REDUCER	ER				
ELBOW UNION	EU				
EXTENDED ELBOW	EE				
FEMALE CONNECTOR	FC				
FEMALE ELBOW	FE				
FLOW CONTROL VALVE (inline)	FV				
MALE ANGLE	MA				
MALE CONNECTOR	MC	Blank = Composite			
MALE ELBOW	ME				
MALE MANIFOLD	MM	B = Nickel Plated Brass			
MANIFOLD UNION	MU	M = Miniature Composite Fittings			
PLUG	PG	S = 316 Stainless Steel			
PLUG-IN ELBOW	PE				
QUICK EXHAUST VALVE	QE				
REDUCED BRANCH	RB				
REDUCED ELBOW	RE				
REDUCED UNION	RU				
RUN TEE	RT				
STACK ELBOW	SE				
SHUTTLE VALVE	ST				
STEM COUPLING	SC				
STEM REDUCER	SR				
STRAIGHT UNION	SU				
TEE UNION	TU				
TEE UNION REDUCER	TU				
TUBE ADAPTOR	TA				
TUBE REDUCER	TR				
UNION VALVE	UV				
UNIVERSAL ELBOW	UE				
Y CONNECTOR	YC				
Y REDUCER	YR				
Y UNION	YU				

www.airoil.com

15 percent off list prices







# Composite Push-In Air Fittings List Price



Composite Fittings													
Model		Male Connector with Internal Hex		Compact Male Connector with Internal Hex		Male Elbow		Branch Tee		Run Tee		Y Connector	
Tube OD	Pipe Size	MC		CC		ME		BT		RT		YC	
1/8	10-32UNF	MC 1/8 10-32	\$1.11	CC 1/8 10-32	\$1.11	ME 1/8 10-32	\$1.61	BT 1/8 10-32	\$2.49	RT 1/8 10-32	\$2.27	YC 1/8 10-32	\$2.27
1/8	NPT1/8	MC 1/8 N1/8	\$1.11	CC 1/8 N1/8	\$1.11	ME 1/8 N1/8	\$1.61	BT 1/8 N1/8	\$2.49	RT 1/8 N1/8	\$2.27	YC 1/8 N1/8	\$2.27
1/8	NPT1/4	MC 1/8 N1/4	\$1.11	CC 1/8 N1/4	\$1.11	ME 1/8 N1/4	\$1.61	BT 1/8 N1/4					
5/32	10-32UNF	MC 5/32 10-32	\$1.11	CC 5/32 10-32	\$1.11	ME 5/32 10-32	\$1.61	BT 5/32 10-32	\$2.49	RT 5/32 10-32	\$2.27	YC 5/32 10-32	\$2.27
5/32	NPT1/8	MC 5/32 N1/8	\$1.11	CC 5/32 N1/8	\$1.11	ME 5/32 N1/8	\$1.61	BT 5/32 N1/8	\$2.49	RT 5/32 N1/8	\$2.27	YC 5/32 N1/8	\$2.27
5/32	NPT1/4	MC 5/32 N1/4	\$1.11	CC 5/32 N1/4	\$1.11	ME 5/32 N1/4	\$1.61	BT 5/32 N1/4	\$2.49	RT 5/32 N1/4	\$2.51	YC 5/32 N1/4	\$2.27
3/16	10-32UNF	MC 3/16 10-32	\$1.11			ME 3/16 10-32	\$1.61	BT 3/16 10-32	\$2.49	RT 3/16 10-32	\$2.51	YC 3/16 10-32	\$2.51
3/16	NPT1/8	MC 3/16 N1/8	\$1.11			ME 3/16 N1/8	\$1.61	BT 3/16 N1/8	\$2.49	RT 3/16 N1/8	\$2.51	YC 3/16 N1/8	\$2.51
3/16	NPT1/4	MC 3/16 N1/4	\$1.11			ME 3/16 N1/4	\$1.61	BT 3/16 N1/4	\$2.49	RT 3/16 N1/4	\$2.51	YC 3/16 N1/4	\$2.51
3/16	NPT3/8	MC 3/16 N3/8	\$1.11			ME 3/16 N3/8	\$1.61	BT 3/16 N3/8	\$2.49	RT 3/16 N3/8	\$2.51	YC 3/16 N3/8	\$2.51
1/4	10-32UNF	MC 1/4 10-32	\$1.11	CC 1/4 10-32	\$1.11	ME 1/4 10-32	\$1.61	BT 1/4 10-32	\$2.51	RT 1/4 10-32	\$3.00	YC 1/4 10-32	\$2.51
1/4	NPT1/8	MC 1/4 N1/8	\$1.11	CC 1/4 N1/8	\$1.11	ME 1/4 N1/8	\$1.61	BT 1/4 N1/8	\$2.51	RT 1/4 N1/8	\$3.00	YC 1/4 N1/8	\$2.51
1/4	NPT1/4	MC 1/4 N1/4	\$1.11	CC 1/4 N1/4	\$1.11	ME 1/4 N1/4	\$1.61	BT 1/4 N1/4	\$2.71	RT 1/4 N1/4	\$3.42	YC 1/4 N1/4	\$2.71
1/4	NPT3/8	MC 1/4 N3/8	\$1.61	CC 1/4 N3/8	\$1.61	ME 1/4 N3/8	\$1.91	BT 1/4 N3/8	\$3.00	RT 1/4 N3/8	\$3.73	YC 1/4 N3/8	\$3.00
5/16	NPT1/8	MC 5/16 N1/8	\$1.11	CC 5/16 N1/8	\$1.11	ME 5/16 N1/8	\$1.78	BT 5/16 N1/8	\$2.82	RT 5/16 N1/8	\$3.12	YC 5/16 N1/8	\$2.82
5/16	NPT1/4	MC 5/16 N1/4	\$1.11	CC 5/16 N1/4	\$1.11	ME 5/16 N1/4	\$1.78	BT 5/16 N1/4	\$2.82	RT 5/16 N1/4	\$3.42	YC 5/16 N1/4	\$2.82
5/16	NPT3/8	MC 5/16 N3/8	\$1.61	CC 5/16 N3/8	\$1.61	ME 5/16 N3/8	\$2.02	BT 5/16 N3/8	\$3.12	RT 5/16 N3/8	\$3.73	YC 5/16 N3/8	\$3.12
3/8	NPT1/8	MC 3/8 N1/8	\$1.66	CC 3/8 N1/8	\$1.66	ME 3/8 N1/8	\$2.02	BT 3/8 N1/8	\$3.00	RT 3/8 N1/8	\$3.73	YC 3/8 N1/8	\$3.12
3/8	NPT1/4	MC 3/8 N1/4	\$1.66	CC 3/8 N1/4	\$1.66	ME 3/8 N1/4	\$2.02	BT 3/8 N1/4	\$3.12	RT 3/8 N1/4	\$3.73	YC 3/8 N1/4	\$3.12
3/8	NPT3/8	MC 3/8 N3/8	\$2.38	CC 3/8 N3/8	\$2.38	ME 3/8 N3/8	\$2.54	BT 3/8 N3/8	\$3.36	RT 3/8 N3/8	\$4.03	YC 3/8 N3/8	\$3.31
3/8	NPT1/2	MC 3/8 N1/2	\$2.38			ME 3/8 N1/2	\$3.70	BT 3/8 N1/2	\$4.36	RT 3/8 N1/2	\$4.36	YC 3/8 N1/2	\$4.03
1/2	NPT1/4	MC 1/2 N1/4	\$2.38	CC 1/2 N1/4	\$3.22	ME 1/2 N1/4	\$3.70	BT 1/2 N1/4	\$4.03	RT 1/2 N1/4	\$4.03	YC 1/2 N1/4	\$4.03
1/2	NPT3/8	MC 1/2 N3/8	\$2.38	CC 1/2 N3/8	\$2.38	ME 1/2 N3/8	\$3.70	BT 1/2 N3/8	\$4.03	RT 1/2 N3/8	\$4.36	YC 1/2 N3/8	\$4.03
1/2	NPT1/2	MC 1/2 N1/2	\$2.38	CC 1/2 N1/2	\$2.38	ME 1/2 N1/2	\$3.70	BT 1/2 N1/2	\$4.36	RT 1/2 N1/2	\$4.65	YC 1/2 N1/2	\$4.36
4 mm	M5X0.8	MC 4 M5	\$1.11			ME 4 M5	\$1.61	BT 4 M5	\$2.27	RT 4 M5	\$2.27	YC 4 M5	\$2.27
4 mm	M6X1	MC 4 M6	\$1.11			ME 4 M6	\$1.61	BT 4 M6	\$2.27	RT 4 M6	\$2.27	YC 4 M6	\$2.27
4 mm	R1/8	MC 4 R1/8	\$1.11			ME 4 R1/8	\$1.61	BT 4 R1/8	\$2.49	RT 4 R1/8	\$2.27	YC 4 R1/8	\$2.27
4 mm	R1/4	MC 4 R1/4	\$1.11			ME 4 R1/4	\$1.61	BT 4 R1/4	\$2.49	RT 4 R1/4	\$2.49	YC 4 R1/4	\$2.49
6 mm	M5X0.8	MC 6 M5	\$1.11			ME 6 M5	\$1.61	BT 6 M5	\$2.51	RT 6 M5	\$3.00	YC 6 M5	\$2.51
6 mm	M6X1	MC 6 M6	\$1.11			ME 6 M6	\$1.61	BT 6 M6	\$2.51	RT 6 M6	\$3.00	YC 6 M6	\$2.51
6 mm	R1/8	MC 6 R1/8	\$1.11			ME 6 R1/8	\$1.61	BT 6 R1/8	\$2.49	RT 6 R1/8	\$3.00	YC 6 R1/8	\$2.51
6 mm	R1/4	MC 6 R1/4	\$1.11			ME 6 R1/4	\$1.61	BT 6 R1/4	\$2.71	RT 6 R1/4	\$3.42	YC 6 R1/4	\$2.71
6 mm	R3/8	MC 6 R3/8	\$1.61			ME 6 R3/8	\$1.91	BT 6 R3/8	\$3.00	RT 6 R3/8	\$3.73	YC 6 R3/8	\$3.00
6 mm	R1/2	MC 6 R1/2	\$2.21			ME 6 R1/2	\$3.15	BT 6 R1/2	\$4.03	RT 6 R1/2	\$4.36	YC 6 R1/2	\$4.03
8 mm	R1/8	MC 8 R1/8	\$1.11			ME 8 R1/8	\$1.78	BT 8 R1/8	\$2.82	RT 8 R1/8	\$3.12	YC 8 R1/8	\$2.82
8 mm	R1/4	MC 8 R1/4	\$1.11			ME 8 R1/4	\$1.78	BT 8 R1/4	\$2.82	RT 8 R1/4	\$3.42	YC 8 R1/4	\$2.82
8 mm	R3/8	MC 8 R3/8	\$1.11			ME 8 R3/8	\$1.78	BT 8 R3/8	\$3.12	RT 8 R3/8	\$3.73	YC 8 R3/8	\$3.12
8 mm	R1/2	MC 8 R1/2	\$1.61			ME 8 R1/2	\$2.02	BT 8 R1/2	\$3.12	RT 8 R1/2	\$4.36	YC 8 R1/2	\$3.99
10 mm	R1/8	MC 10 R1/8	\$1.66			ME 10 R1/8	\$2.02	BT 10 R1/8	\$3.00	RT 10 R1/8	\$3.73	YC 10 R1/8	\$3.12
10 mm	R1/4	MC 10 R1/4	\$1.66			ME 10 R1/4	\$2.02	BT 10 R1/4	\$3.12	RT 10 R1/4	\$3.73	YC 10 R1/4	\$3.12
10 mm	R3/8	MC 10 R3/8	\$2.38			ME 10 R3/8	\$2.26	BT 10 R3/8	\$3.36	RT 10 R3/8	\$3.99	YC 10 R3/8	\$3.31
10 mm	R1/2	MC 10 R1/2	\$2.38			ME 10 R1/2	\$3.70	BT 10 R1/2	\$4.36	RT 10 R1/2	\$4.36	YC 10 R1/2	\$4.03
12 mm	R1/4	MC 12 R1/4	\$2.38			ME 12 R1/4	\$3.70	BT 12 R1/4	\$4.03	RT 12 R1/4	\$4.03	YC 12 R1/4	\$4.03
12 mm	R3/8	MC 12 R3/8	\$2.38			ME 12 R3/8	\$3.70	BT 12 R3/8	\$4.03	RT 12 R3/8	\$4.36	YC 12 R3/8	\$4.03
12 mm	R1/2	MC 12 R1/2	\$2.38			ME 12 R1/2	\$3.70	BT 12 R1/2	\$4.36	RT 12 R1/2	\$4.65	YC 12 R1/2	\$4.36



# Composite Push-In Air Fittings List Price

Composite Fittings													
Model		Universal Elbow		Extended Elbow		Female Connector		Female Elbow		Bulkhead Connector		Control Valve CV=meter-out; CI= meter-in	
Tube OD	Pipe Size	UE		EE		FC		FE		BC		CV or CI	
1/8	10-32UNF	UE 1/8 10-32	\$2.51			FC 1/8 10-32	\$1.41	FE 1/8 10-32	\$2.00			CV 1/8 10-32	\$6.17
1/8	NPT1/8	UE 1/8 N1/8	\$2.51			FC 1/8 N1/8	\$1.41	FE 1/8 N1/8	\$2.00	BC 1/8 N1/8	\$2.65	CV 1/8 N1/8	\$6.17
5/32	10-32UNF	UE 5/32 10-32	\$2.51	EE 5/32 10-32	\$2.00	FC 5/32 10-32	\$1.41	FE 5/32 10-32	\$2.00			CV 5/32 10-32	\$6.17
5/32	NPT1/8	UE 5/32 N1/8	\$2.51	EE 5/32 N1/8	\$2.00	FC 5/32 N1/8	\$1.41	FE 5/32 N1/8	\$2.00	BC 5/32 N1/8	\$2.65	CV 5/32 N1/8	\$6.17
5/32	NPT1/4					FC 5/32 N1/4	\$1.41	FE 5/32 N1/4	\$2.00	BC 5/32 N1/4	\$2.65	CV 5/32 N1/4	\$6.17
3/16	10-32UNF	UE 3/16 10-32	\$3.00					FE 3/16 10-32	\$2.00				
3/16	NPT1/8	UE 3/16 N1/8	\$3.00	EE 3/16 N1/8	\$2.00			FE 3/16 N1/8	\$2.00	BC 3/16 N1/8	\$2.65	CV 3/16 N1/8	\$6.17
3/16	NPT1/4	UE 3/16 N1/4	\$3.00	EE 3/16 N1/4	\$2.00			FE 3/16 N1/4	\$2.00	BC 3/16 N1/4	\$2.65		
3/16	NPT3/8			EE 3/16 N3/8	\$2.53								
1/4	10-32UNF	UE 1/4 10-32	\$3.00					FE 1/4 10-32	\$2.00			CV 1/4 10-32	\$6.17
1/4	NPT1/8	UE 1/4 N1/8	\$3.00	EE 1/4 N1/8	\$2.00	FC 1/4 N1/8	\$1.41	FE 1/4 N1/8	\$2.00	BC 1/4 N1/8	\$3.17	CV 1/4 N1/8	\$6.67
1/4	NPT1/4	UE 1/4 N1/4	\$3.42	EE 1/4 N1/4	\$2.00	FC 1/4 N1/4	\$1.60	FE 1/4 N1/4	\$2.00	BC 1/4 N1/4	\$3.62	CV 1/4 N1/4	\$6.67
1/4	NPT3/8			EE 1/4 N3/8	\$2.53			FE 1/4 N3/8	\$2.53			CV 1/4 N3/8	\$8.50
5/16	NPT1/8	UE 5/16 N1/8	\$3.12	EE 5/16 N1/8	\$2.16	FC 5/16 N1/8	\$1.61	FE 5/16 N1/8	\$2.16	BC 5/16 N1/8	\$3.30	CV 5/16 N1/8	\$6.67
5/16	NPT1/4	UE 5/16 N1/4	\$3.12	EE 5/16 N1/4	\$2.16	FC 5/16 N1/4	\$1.61	FE 5/16 N1/4	\$2.16	BC 5/16 N1/4	\$3.62	CV 5/16 N1/4	\$6.67
5/16	NPT3/8	UE 5/16 N3/8	\$3.73	EE 5/16 N3/8	\$2.38	FC 5/16 N3/8	\$1.90	FE 5/16 N3/8	\$2.38			CV 5/16 N3/8	\$8.50
3/8	NPT1/8	UE 3/8 N1/8	\$3.73										
3/8	NPT1/4	UE 3/8 N1/4	\$3.73	EE 3/8 N1/4	\$2.98	FC 3/8 N1/4	\$2.15	FE 3/8 N1/4	\$2.98	BC 3/8 N1/4	\$3.62	CV 3/8 N1/4	\$7.28
3/8	NPT3/8	UE 3/8 N3/8	\$4.03	EE 3/8 N3/8	\$2.98	FC 3/8 N3/8	\$2.15	FE 3/8 N3/8	\$2.98	BC 3/8 N3/8	\$4.27	CV 3/8 N3/8	\$8.50
3/8	NPT1/2			EE 3/8 N1/2	\$4.47	FC 3/8 N1/2	\$3.25	FE 3/8 N1/2	\$4.47			CV 3/8 N1/2	\$10.15
1/2	NPT1/4			EE 1/2 N1/4	\$4.47	FC 1/2 N1/4	\$3.25						
1/2	NPT3/8	UE 1/2 N3/8	\$4.36	EE 1/2 N3/8	\$4.47	FC 1/2 N3/8	\$3.25			BC 1/2 N3/8	\$4.58	CV 1/2 N3/8	\$9.72
1/2	NPT1/2	UE 1/2 N1/2	\$4.65	EE 1/2 N1/2	\$4.47					BC 1/2 N1/2	\$4.91	CV 1/2 N1/2	\$10.15
4 mm	M5X0.8	UE 4 M5	\$2.51	EE 4 M5	\$2.00			FE 4 M5	\$2.00			CV 4 M5	\$6.17
4 mm	M6X1	UE 4 M6	\$2.51	EE 4 M6	\$2.00			FE 4 M6	\$2.00			CV 4 M6	\$6.17
4 mm	R1/8	UE 4 R1/8	\$2.51	EE 4 R1/8	\$2.00	FC 4 R1/8	\$1.41	FE 4 R1/8	\$2.00	BC 4 R1/8	\$2.65	CV 4 R1/8	\$6.17
4 mm	R1/4	UE 4 R1/4	\$3.00	EE 4 R1/4	\$2.00	FC 4 R1/4	\$1.41	FE 4 R1/4	\$2.00	BC 4 R1/4	\$2.65	CV 4 R1/4	\$6.67
6 mm	M5X0.8	UE 6 M5	\$3.00	EE 6 M5	\$2.00			FE 6 M5	\$2.00			CV 6 M5	\$6.17
6 mm	M6X1	UE 6 M6	\$3.00	EE 6 M6	\$2.00			FE 6 M6	\$2.00			CV 6 M6	\$6.17
6 mm	R1/8	UE 6 R1/8	\$3.00	EE 6 R1/8	\$2.00	FC 6 R1/8	\$1.41	FE 6 R1/8	\$2.00	BC 6 R1/8	\$3.17	CV 6 R1/8	\$6.67
6 mm	R1/4	UE 6 R1/4	\$3.42	EE 6 R1/4	\$2.00	FC 6 R1/4	\$1.60	FE 6 R1/4	\$2.00	BC 6 R1/4	\$3.62	CV 6 R1/4	\$6.67
6 mm	R3/8	UE 6 R3/8	\$3.73	EE 6 R3/8	\$2.53	FC 6 R3/8	\$1.90	FE 6 R3/8	\$2.53	BC 6 R3/8	\$3.95	CV 6 R3/8	\$8.50
6 mm	R1/2			EE 6 R1/2	\$3.95								
8 mm	R1/8	UE 8 R1/8	\$3.12	EE 8 R1/8	\$2.16	FC 8 R1/8	\$1.61	FE 8 R1/8	\$2.16	BC 8 R1/8	\$3.30	CV 8 R1/8	\$6.67
8 mm	R1/4	UE 8 R1/4	\$3.12	EE 8 R1/4	\$2.16	FC 8 R1/4	\$1.61	FE 8 R1/4	\$2.16	BC 8 R1/4	\$3.62	CV 8 R1/4	\$6.67
8 mm	R3/8	UE 8 R3/8	\$3.73	EE 8 R3/8	\$2.38	FC 8 R3/8	\$1.90	FE 8 R3/8	\$2.38	BC 8 R3/8	\$3.95	CV 8 R3/8	\$6.67
8 mm	R1/2	UE 8 R1/2	\$4.36	EE 8 R1/2	\$3.95	FC 8 R1/2	\$3.12			BC 8 R1/2	\$4.58	CV 8 R1/2	\$8.50
10 mm	R1/8			EE 10 R1/8	\$2.98	FC 10 R1/8	\$2.15	FE 10 R1/8	\$2.98	BC 10 R1/8	\$3.62		
10 mm	R1/4	UE 10 R1/4	\$3.73	EE 10 R1/4	\$2.98	FC 10 R1/4	\$2.15	FE 10 R1/4	\$2.98	BC 10 R1/4	\$3.95	CV 10 R1/4	\$7.28
10 mm	R3/8	UE 10 R3/8	\$4.03	EE 10 R3/8	\$2.98	FC 10 R3/8	\$2.15	FE 10 R3/8	\$2.98	BC 10 R3/8	\$4.27	CV 10 R3/8	\$8.50
10 mm	R1/2	UE 10 R1/2	\$4.36	EE 10 R1/2	\$4.47	FC 10 R1/2	\$3.25	FE 10 R1/2	\$4.47	BC 10 R1/2	\$4.58	CV 10 R1/2	\$10.15
12 mm	R1/4	UE 12 R1/4	\$4.36	EE 12 R1/4	\$4.47	FC 12 R1/4	\$3.25	FE 12 R1/4	\$4.47	BC 12 R1/4	\$4.27	CV 12 R1/4	\$9.72
12 mm	R3/8	UE 12 R3/8	\$4.36	EE 12 R3/8	\$4.47	FC 12 R3/8	\$3.25	FE 12 R3/8	\$4.47	BC 12 R3/8	\$4.58	CV 12 R3/8	\$9.72
12 mm	R1/2	UE 12 R1/2	\$4.65	EE 12 R1/2	\$4.47	FC 12 R1/2	\$3.25	FE 12 R1/2	\$4.47	BC 12 R1/2	\$4.91	CV 12 R1/2	\$10.15

# Composite Push-In Air Fittings List Price



Composite Fittings														
Model	Flow Valve		Bulkhead Union		Cross Union		Elbow Union		Straight Union		Tee Union		Y Union	
Tube OD	FV		BU		CU		EU		SU		TU		YU	
1/8	FV 1/8	\$7.15	BU 1/8	\$2.60	CU 1/8	\$3.08	EU 1/8	\$1.32	SU 1/8	\$1.32	TU 1/8	\$1.96	YU 1/8	\$1.96
5/32	FV 5/32	\$7.15	BU 5/32	\$2.60	CU 5/32	\$3.08	EU 5/32	\$1.32	SU 5/32	\$1.32	TU 5/32	\$1.96	YU 5/32	\$1.96
3/16	FV 3/16	\$7.15	BU 3/16	\$2.60	CU 3/16	\$3.08	EU 3/16	\$1.32	SU 3/16	\$1.32	TU 3/16	\$1.96	YU 3/16	\$1.96
1/4	FV 1/4	\$7.37	BU 1/4	\$2.60	CU 1/4	\$3.08	EU 1/4	\$1.39	SU 1/4	\$1.39	TU 1/4	\$1.96	YU 1/4	\$1.96
5/16	FV 5/16	\$7.37	BU 5/16	\$3.15	CU 5/16	\$3.08	EU 5/16	\$1.62	SU 5/16	\$1.60	TU 5/16	\$1.96	YU 5/16	\$1.96
3/8	FV 3/8	\$7.48	BU 3/8	\$3.81	CU 3/8	\$3.85	EU 3/8	\$1.84	SU 3/8	\$1.84	TU 3/8	\$2.44	YU 3/8	\$2.44
1/2	FV 1/2	\$9.68	BU 1/2	\$3.92	CU 1/2	\$4.76	EU 1/2	\$2.15	SU 1/2	\$2.15	TU 1/2	\$3.06	YU 1/2	\$3.06
4 mm	FV 04	\$7.37	BU 4	\$2.60	CU 4	\$3.08	EU 4	\$1.32	SU 4	\$1.32	TU 4	\$1.96	YU 4	\$1.96
6 mm	FV 06	\$7.37	BU 6	\$2.60	CU 6	\$3.08	EU 6	\$1.39	SU 6	\$1.39	TU 6	\$1.96	YU 6	\$1.96
8 mm	FV 08	\$7.48	BU 8	\$3.15	CU 8	\$3.85	EU 8	\$1.60	SU 8	\$1.60	TU 8	\$1.96	YU 8	\$1.96
10 mm	FV 10	\$10.78	BU 10	\$3.81	CU 10	\$4.54	EU 10	\$1.84	SU 10	\$1.84	TU 10	\$2.44	YU 10	\$2.44
12 mm	FV 12	\$11.99	BU 12	\$3.92	CU 12	\$4.76	EU 12	\$2.15	SU 12	\$2.15	TU 12	\$3.06	YU 12	\$3.06
Composite Fittings														
Model	Elbow Reducer (Tube-Stem)		Plug In Elbow		Male Manifold		Manifold Union		Reduced Branch		Reduced Union		Tee Union Reducer	
Tube OD	ER		PE		MM		MU		RB		RU		TU	
1/8	ER 1/8-5/32	\$2.56	PE 1/8	\$2.56	MM 1/4-5/32-N1/8	\$4.40	MU 5/32X1/8	\$3.96	RB 5/32-1/8	\$2.56	RU 5/32-1/8	\$1.60	TU 5/32-1/8	\$2.56
5/32	ER 5/32-1/4	\$2.56	PE 5/32	\$2.56	MM 5/16-5/32-N1/4	\$4.51	MU 1/4X5/32	\$3.96	RB 3/16-5/32	\$2.56	RU 3/16-5/32	\$1.60		
3/16			PE 3/16		MM 5/16-1/4-N1/4	\$4.51	MU 5/16X5/32	\$3.96	RB 1/4-5/32	\$2.56	RU 1/4-5/32	\$1.60	TU 1/4-5/32	\$2.56
1/4	ER 1/4-5/16	\$2.56	PE 1/4	\$2.56			MU 5/16X1/4	\$3.96	RB 1/4-3/16	\$2.56	RU 1/4-3/16	\$1.84	TU 1/4-3/16	
5/16	ER 5/16-3/8	\$2.56	PE 5/16	\$2.56			MU 3/8X1/4	\$5.50	RB 5/16-1/4	\$2.56	RU 5/16-1/4	\$1.84	TU 5/16-1/4	\$2.56
3/8	ER 3/8-1/2	\$3.66	PE 3/8	\$3.06					RB 3/8-1/4	\$3.06	RU 3/8-1/4	\$2.15	TU 3/8-1/4	\$3.06
1/2			PE 1/2	\$3.06					RB 3/8-5/16	\$3.06	RU 3/8-5/16	\$2.15	TU 3/8-5/16	\$3.06
4 mm					MM 06-04-R1/8	\$4.51	MU 6-4	\$3.96	RB 1/2-3/8	\$3.66	RU 1/2-3/8	\$2.44	TU 1/2-3/8	\$3.66
6 mm	ER 4-6	\$2.56	PE 4		MM 08-04-R1/4	\$4.51	MU 8-4	\$3.96	RB 6-4	\$2.56	RU 6-4	\$1.60	TU 6-4	\$2.56
8 mm	ER 6-8	\$2.56	PE 6		MM 08-06-R3/8	\$5.83	MU 8-6	\$4.51	RB 8-6	\$2.56	RU 8-6	\$1.84	TU 8-6	\$2.56
10 mm	ER 8-10	\$3.06	PE 8		MM 10-08-R3/8	\$6.16	MU 10-6	\$5.17	RB 10-8	\$3.06	RU 10-8	\$2.15	TU 10-8	\$3.06
12 mm	ER 10-12	\$3.66	PE 10				MU 10-8	\$5.17	RB 12-10	\$3.66	RU 12-10	\$2.44	TU 12-10	\$3.66
Composite Fittings														
Model	Plug		Stem Coupler		Stem Reducer		Tube Reducer (Tube-Stem)		Model		Stack Elbow		Male Angle	
Tube OD	PG		SC		SR		TR		Tube OD	Pipe Size	SE		MA	
1/8	PG 1/8	\$0.55	SC 1/8	\$0.66					5/32	10-32	SE 5/32 10-32	\$2.51	MA 5/32 10-32	\$2.51
5/32	PG 5/32	\$0.55	SC 5/32	\$0.66	SR 1/8-5/32	\$0.88	TR 1/8-5/32	\$1.68	5/32	NPT1/8	SE 5/32 N1/8	\$2.51	MA 5/32 N1/8	\$2.51
3/16									1/4	10-32	SE 1/4 10-32	\$3.00	MA 1/4 10-32	\$3.00
1/4	PG 1/4	\$0.55	SC 1/4	\$0.66	SR 5/32-1/4	\$0.88	TR 5/32-1/4	\$1.68	1/4	NPT1/8	SE 1/4 N1/8	\$3.00	MA 1/4 N1/8	\$3.00
5/16	PG 5/16	\$0.66	SC 5/16	\$0.88	SR 1/4-5/16	\$1.10	TR 1/4-5/16	\$1.98	1/4	NPT1/4	SE 1/4 N1/4	\$3.42	MA 1/4 N1/4	\$3.42
3/8	PG 3/8	\$0.66	SC 3/8	\$0.88	SR 1/4-3/8	\$1.10	TR 1/4-3/8	\$1.98	5/16	NPT1/4	SE 5/16 N1/4	\$3.12	MA 5/16 N1/4	\$3.12
1/2	PG 1/2	\$0.66	SC 1/2	\$0.88	SR 3/8-1/2	\$1.10	TR 3/8-1/2	\$2.68	5/16	NPT3/8	SE 5/16 N3/8	\$3.73	MA 5/16 N3/8	\$3.73
4 mm	PG 4	\$0.55	SC 4	\$0.66					3/8	NPT1/4	SE 3/8 N1/4	\$3.73	MA 3/8 N1/4	\$3.73
6 mm	PG 6	\$0.55	SC 6	\$0.66	SR 4-6	\$0.88	TR 4-6	\$1.68	3/8	NPT3/8	SE 3/8 N3/8	\$4.03	MA 3/8 N3/8	\$4.03
8 mm	PG 8	\$0.66	SC 8	\$0.88	SR 6-8	\$0.88	TR 6-8	\$1.98						
10 mm	PG10	\$0.66	SC10	\$0.88	SR 8-10	\$1.10	TR 8-10	\$1.98	1/2	NPT3/8	SE 1/2 N3/8	\$4.36	MA 1/2 N3/8	\$4.36
12 mm	PG 12	\$0.66	SC 12	\$0.88	SR 10-12	\$1.10	TR 10-12	\$2.68	1/2	NPT1/2	SE 1/2 N1/2	\$4.65	MA 1/2 N1/2	\$4.65

# Miniature Composite Push-In Air Fittings List Price

## STC Polyurethane Air Tubing List Price

Model		Male Connector		Compact Male Connector With Internal Hex			Male Elbow		Branch Tee		Run Tee		Female Connector	
Tube OD	Pipe Size	MCM		CCM			MEM		BTM		RTM		FCM	
1/8	10-32UNF	MCM 1/8 10-32	\$1.70	CCM 1/8 10-32	\$1.85	MEM 1/8 10-32	\$2.50	BTM 1/8 10-32	\$4.00	RTM 1/8 10-32	\$2.27	FCM 1/8 10-32	\$2.20	
1/8	NPT1/8	MCM 1/8 N1/8	\$1.70	CCM 1/8 N1/8	\$1.85	MEM 1/8 N1/8	\$2.50	BTM 1/8 N1/8	\$4.00	RTM 1/8 N1/8	\$2.27	FCM 1/8 N1/8	\$2.20	
5/32	10-32UNF	MCM 5/32 10-32	\$1.70	CCM 5/32 10-32	\$1.85	MEM 5/32 10-32	\$2.50	BTM 5/32 10-32	\$4.00	RTM 5/32 10-32	\$2.27	FCM 5/32 10-32	\$2.20	
5/32	NPT1/8	MCM 5/32 N1/8	\$1.70	CCM 5/32 N1/8	\$1.85	MEM 5/32 N1/8	\$2.50	BTM 5/32 N1/8	\$4.00	RTM 5/32 N1/8	\$2.27	FCM 5/32 N1/8	\$2.20	
1/4	10-32UNF	MCM 1/4 10-32	\$1.70	CCM 1/4 10-32	\$1.85	MEM 1/4 10-32	\$2.50	BTM 1/4 10-32	\$4.00	RTM 1/4 10-32	\$3.00	FCM 1/4 10-32	\$2.20	
1/4	NPT1/8	MCM 1/4 N1/8	\$1.70	CCM 1/4 N1/8	\$1.85	MEM 1/4 N1/8	\$2.50	BTM 1/4 N1/8	\$4.00	RTM 1/4 N1/8	\$3.00	FCM 1/4 N1/8	\$2.20	

Model		Cross Union		Elbow Union		Straight Union		Straight Union	
Tube OD		CUM		EUM		SUM		TUM	
1/8		CUM 1/8	\$4.00	EUM 1/8	\$2.30	SUM 1/8	\$2.30	TUM 1/8	\$3.20
5/32		CUM 5/32	\$4.00	EUM 5/32	\$2.30	SUM 5/32	\$2.30	TUM 5/32	\$3.20
1/4		CUM 1/4	\$4.00	EUM 1/4	\$2.30	SUM 1/4	\$2.30	TUM 1/4	\$3.20

### STC Polyurethane Tubing Numbering System

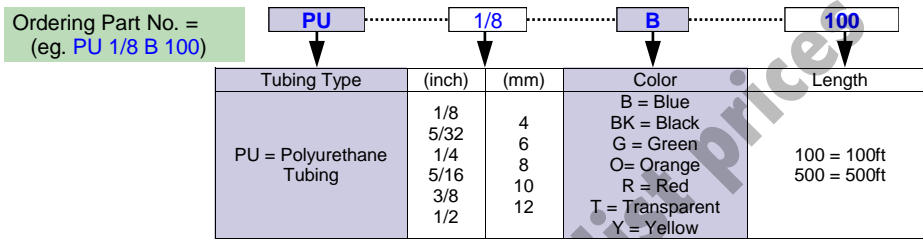

Specifications	
Temperature	-40 to 176°F, (-40 to 80°C)
Durometer	Shore A: 90
Size Tolerance	+/- 0.004" (+/- 0.1mm)

STC Polyurethane Tubing	
Tubing Size	1/8", 5/32", 1/4", 5/16", 3/8", 1/2"; 4 mm, 6 mm, 8 mm, 10 mm, 12 mm
Length	100 ft or 500 ft (roll in a spool)
Color	Black Blue Clear Green Orange Red Yellow

Tubing Size		Part No.									Color Tubing Price
OD	ID	Max Pressure PSI @ 75° F	Transparent	Black	Blue	Green	Orange	Red	Yellow		
1/8"	0.078"	200	PU 1/8 T-100	PU 1/8 BK-100	PU 1/8 B-100	PU 1/8 G-100	PU 1/8 O-100	PU 1/8 R-100	PU 1/8 Y-100	\$12.80/100 ft	
5/32"	0.098"	200	PU 5/32 T-100	PU 5/32 BK-100	PU 5/32 B-100	PU 5/32 G-100	PU 5/32 O-100	PU 5/32 R-100	PU 5/32 Y-100	\$15.30/100 ft	
1/4"	0.16"	180	PU 1/4 T-100	PU 1/4 BK-100	PU 1/4 B-100	PU 1/4 G-100	PU 1/4 O-100	PU 1/4 R-100	PU 1/4 Y-100	\$24.00/100 ft	
5/16"	0.20"	180	PU 5/16 T-100	PU 5/16 BK-100	PU 5/16 B-100	PU 5/16 G-100	PU 5/16 O-100	PU 5/16 R-100	PU 5/16 Y-100	\$33.00/100 ft	
3/8"	0.26"	150	PU 3/8 T-100	PU 3/8 BK-100	PU 3/8 B-100	PU 3/8 G-100	PU 3/8 O-100	PU 3/8 R-100	PU 3/8 Y-100	\$45.80/100 ft	
1/2"	3/8"	150	PU 1/2 T-100	PU 1/2 BK-100	PU 1/2 B-100	PU 1/2 G-100	PU 1/2 O-100	PU 1/2 R-100	PU 1/2 Y-100	\$73.42/100 ft	
4mm	2mm	200	PU 4 T-100	PU 4 BK-100	PU 4 B-100	PU 4 G-100	PU 4 O-100	PU 4 R-100	PU 4 Y-100	\$15.30/100 ft	
6mm	4mm	180	PU 6 T-100	PU 6 BK-100	PU 6 B-100	PU 6 G-100	PU 6 O-100	PU 6 R-100	PU 6 Y-100	\$22.00/100 ft	
8mm	5mm	180	PU 8 T-100	PU 8 BK-100	PU 8 B-100	PU 8 G-100	PU 8 O-100	PU 8 R-100	PU 8 Y-100	\$35.00/100 ft	
10mm	6.5mm	150	PU 10 T-100	PU 10 BK-100	PU 10 B-100	PU 10 G-100	PU 10 O-100	PU 10 R-100	PU 10 Y-100	\$55.00/100 ft	
12mm	8mm	150	PU 12 T-100	PU 12 BK-100	PU 12 B-100	PU 12 G-100	PU 12 O-100	PU 12 R-100	PU 12 Y-100	\$73.00/100 ft	

1/8"	0.078"	200	PU 1/8 T-500	PU 1/8 BK-500	PU 1/8 B-500	PU 1/8 G-500	PU 1/8 O-500	PU 1/8 R-500	PU 1/8 Y-500	\$64.00/500 ft
5/32"	0.098"	200	PU 5/32 T-500	PU 5/32 BK-500	PU 5/32 B-500	PU 5/32 G-500	PU 5/32 O-500	PU 5/32 R-500	PU 5/32 Y-500	\$76.50/500 ft
1/4"	0.16"	180	PU 1/4 T-500	PU 1/4 BK-500	PU 1/4 B-500	PU 1/4 G-500	PU 1/4 O-500	PU 1/4 R-500	PU 1/4 Y-500	\$120.00/500 ft
5/16"	0.20"	180	PU 5/16 T-500	PU 5/16 BK-500	PU 5/16 B-500	PU 5/16 G-500	PU 5/16 O-500	PU 5/16 R-500	PU 5/16 Y-500	\$165.00/500 ft
3/8"	0.26"	150	PU 3/8 T-500	PU 3/8 BK-500	PU 3/8 B-500	PU 3/8 G-500	PU 3/8 O-500	PU 3/8 R-500	PU 3/8 Y-500	\$229.00/500 ft
1/2"	3/8"	150	PU 1/2 T-500	PU 1/2 BK-500	PU 1/2 B-500	PU 1/2 G-500	PU 1/2 O-500	PU 1/2 R-500	PU 1/2 Y-500	\$367.10/500 ft
5/32"	2mm	200	PU 4 T-500	PU 4 BK-500	PU 4 B-500	PU 4 G-500	PU 4 O-500	PU 4 R-500	PU 4 Y-500	\$76.00/500 ft
6mm	4mm	180	PU 6 T-500	PU 6 BK-500	PU 6 B-500	PU 6 G-500	PU 6 O-500	PU 6 R-500	PU 6 Y-500	\$110.00/500 ft
8mm	5mm	180	PU 8 T-500	PU 8 BK-500	PU 8 B-500	PU 8 G-500	PU 8 O-500	PU 8 R-500	PU 8 Y-500	\$175.00/500 ft
10mm	6.5mm	150	PU 10 T-500	PU 10 BK-500	PU 10 B-500	PU 10 G-500	PU 10 O-500	PU 10 R-500	PU 10 Y-500	\$275.00/500 ft
12mm	8mm	150	PU 12 T-500	PU 12 BK-500	PU 12 B-500	PU 12 G-500	PU 12 O-500	PU 12 R-500	PU 12 Y-500	\$365.00/500 ft
1/4"	0.16"	180	PU 1/4 B-10	10 ft Polyurethane Tubing Coil						\$2.60/each
3/8"	0.26"	150	PU 3/8 B-10	10 ft Polyurethane Tubing Coil						\$5.70/each



# Stainless Steel Push-In Fittings List Price







Stainless Steel Fittings										
	Name	Bulkhead Union	Elbow Union		Straight Union		Tee Union		Tube Reducer	
Tube OD	Part No.	Unit Price	Part No.	Unit Price	Part No.	Unit Price	Part No.	Unit Price	Part No.	Unit Price
1/8"	BUS 1/8	\$12.61	EUS 1/8	\$15.11	SUS 1/8	\$9.50	TUS 1/8	\$18.55	TRS 1/8	\$9.50
5/32"	BUS 5/32	\$12.61	EUS 5/32	\$15.11	SUS 5/32	\$9.50	TUS 5/32	\$18.55	TRS 5/32	\$9.50
1/4"	BUS 1/4	\$14.85	EUS 1/4	\$17.36	SUS 1/4	\$9.50	TUS 1/4	\$21.32	TRS 1/4	\$9.50
5/16"	BUS 5/16	\$18.98	EUS 5/16	\$18.15	SUS 5/16	\$10.36	TUS 5/16	\$24.09	TRS 5/16	\$10.36
3/8"	BUS 3/8	\$20.20	EUS 3/8	\$19.80	SUS 3/8	\$11.22	TUS 3/8	\$26.80	TRS 3/8	\$11.22
1/2"	BUS 1/2	\$26.07	EUS 1/2	\$22.77	SUS 1/2	\$13.60	TUS 1/2	\$31.35	TRS 1/2	\$13.60

4 mm	BUS 4	\$12.61	EUS 4	\$15.11	SUS 4	\$8.51	TUS 4	\$18.55	TRS 4	\$8.51
6 mm	BUS 6	\$14.85	EUS 6	\$17.36	SUS 6	\$9.50	TUS 6	\$21.32	TRS 6	\$9.50
8 mm	BUS 8	\$18.98	EUS 8	\$18.15	SUS 8	\$10.36	TUS 8	\$24.09	TRS 8	\$10.36
10 mm	BUS 10	\$20.20	EUS 10	\$19.80	SUS 10	\$11.22	TUS 10	\$26.80	TRS 10	\$11.22
12 mm	BUS 12	\$26.07	EUS 12	\$22.77	SUS 12	\$13.60	TUS 12	\$31.35	TRS 12	\$13.60





Stainless Steel Fittings													
	Name	Branch Tee		Female Connector		Male Connector		Male Elbow, Swivel		Y Connector, Swivel			
Tube OD	Thread	Part No.	Unit Price	Part No.	Unit Price	Part No.	Unit Price	Part No.	Unit Price	Part No.	Unit Price	Part No.	Unit Price
1/8"	10-32	BTS 1/8 10-32	\$18.55	FCS 1/8 10-32	\$7.70	MCS 1/8 10-32	\$6.60	MES 1/8 10-32	\$13.13	RTS 1/8 10-32	\$18.55	TAS 1/8 10-32	\$4.60
1/8"	1/8" NPT	BTS 1/8 N1/8	\$18.55	FCS 1/8 N1/8	\$7.70	MCS 1/8 N1/8	\$6.60	MES 1/8 N1/8	\$13.13	RTS 1/8 N1/8	\$18.55	TAS 1/8 N1/8	\$4.60
5/32"	10-32	BTS 5/32 10-32	\$18.55	FCS 5/32 10-32	\$7.70	MCS 5/32 10-32	\$6.60	MES 5/32 10-32	\$13.13	RTS 5/32 10-32	\$18.55	TAS 5/32 10-32	\$4.60
5/32"	1/8" NPT	BTS 5/32 N1/8	\$18.55	FCS 5/32 N1/8	\$7.70	MCS 5/32 N1/8	\$6.60	MES 5/32 N1/8	\$13.13	RTS 5/32 N1/8	\$18.55	TAS 5/32 N1/8	\$4.60
1/4"	1/8" NPT	BTS 1/4 N1/8	\$18.55	FCS 1/4 N1/8	\$7.70	MCS 1/4 N1/8	\$6.60	MES 1/4 N1/8	\$13.98	RTS 1/4 N1/8	\$18.55	TAS 1/4 N1/8	\$4.60
1/4"	1/4" NPT	BTS 1/4 N1/4	\$21.32	FCS 1/4 N1/4	\$7.70	MCS 1/4 N1/4	\$6.60	MES 1/4 N1/4	\$15.11	RTS 1/4 N1/4	\$21.32	TAS 1/4 N1/4	\$4.60
1/4"	3/8" NPT	BTS 1/4 N3/8	\$24.32	FCS 1/4 N3/8	\$8.29	MCS 1/4 N3/8	\$7.19	MES 1/4 N3/8	\$15.71	RTS 1/4 N3/8	\$24.32	TAS 1/4 N3/8	\$5.19
5/16"	1/4" NPT	BTS 5/16 N1/4	\$23.32	FCS 5/16 N1/4	\$9.88	MCS 5/16 N1/4	\$8.78	MES 5/16 N1/4	\$16.50	RTS 5/16 N1/4	\$23.32	TAS 5/16 N1/4	\$6.78
5/16"	3/8" NPT	BTS 5/16 N3/8	\$25.32	FCS 5/16 N3/8	\$10.88	MCS 5/16 N3/8	\$9.28	MES 5/16 N3/8	\$16.88	RTS 5/16 N3/8	\$25.32	TAS 3/8 N1/8	\$6.78
3/8"	1/4" NPT	BTS 3/8 N1/4	\$26.80	FCS 3/8 N1/4	\$11.88	MCS 3/8 N1/4	\$8.78	MES 3/8 N1/4	\$17.49	RTS 3/8 N1/4	\$26.80	TAS 3/8 N1/4	\$6.78
3/8"	3/8" NPT	BTS 3/8 N3/8	\$26.80	FCS 3/8 N3/8	\$12.68	MCS 3/8 N3/8	\$8.91	MES 3/8 N3/8	\$18.15	RTS 3/8 N3/8	\$26.80	TAS 3/8 N3/8	\$6.91
3/8"	1/2" NPT	BTS 3/8 N1/2	\$29.80	FCS 3/8 N1/2	\$12.98	MCS 3/8 N1/2	\$10.00	MES 3/8 N1/2	\$20.79	RTS 3/8 N1/2	\$29.80	TAS 3/8 N1/2	\$8.00
1/2"	1/4" NPT	BTS 1/2 N1/4	\$28.35	FCS 1/2 N1/4	\$12.86	MCS 1/2 N1/4	\$10.76	MES 1/2 N1/4	\$22.31	RTS 1/2 N1/4	\$28.35	TAS 1/2 N1/4	\$8.76
1/2"	3/8" NPT	BTS 1/2 N3/8	\$29.35	FCS 1/2 N3/8	\$13.29	MCS 1/2 N3/8	\$10.76	MES 1/2 N3/8	\$22.31	RTS 1/2 N3/8	\$29.35	TAS 1/2 N3/8	\$8.76
1/2"	1/2" NPT	BTS 1/2 N1/2	\$31.35	FCS 1/2 N1/2	\$15.29	MCS 1/2 N1/2	\$14.19	MES 1/2 N1/2	\$25.41	RTS 1/2 N1/2	\$31.35	TAS 1/2 N1/2	\$12.19

4 mm	M5	BTS 4 M5	\$18.55	FCS 4 M5	\$7.70	MCS 4 M5	\$6.60	MES 4 M5	\$13.13	RTS 4 M5	\$18.55
4 mm	R1/8	BTS 4 R1/8	\$18.55	FCS 4 N1/8	\$7.70	MCS 4 R1/8	\$6.60	MES 4 R1/8	\$13.13	RTS 4 R1/8	\$18.55
4 mm	R1/4	BTS 4 R1/4	\$18.55	FCS 4 R1/4	\$7.70	MCS 4 R1/4	\$6.60	MES 4 R1/4	\$13.13	RTS 4 R1/4	\$18.55
6mm	M5	BTS 6 M5	\$18.55	FCS 6 M5	\$7.70	MCS 6 M5	\$6.60	MES 6 M5	\$13.13	RTS 6 M5	\$18.55
6mm	R1/8	BTS 6 R1/8	\$18.55	FCS 6 R1/8	\$7.70	MCS 6 R1/8	\$6.60	MES 6 R1/8	\$13.13	RTS 6 R1/8	\$18.55
6mm	R1/4	BTS 6 R1/4	\$21.32	FCS 6 R1/4	\$7.70	MCS 6 R1/4	\$6.60	MES 6 R1/4	\$15.11	RTS 6 R1/4	\$21.32
8 mm	R1/4	BTS 8 R1/4	\$23.32	FCS 8 N1/4	\$9.88	MCS 8 R1/4	\$8.78	MES 8 R1/4	\$16.50	RTS 8 R1/4	\$23.32
8 mm	R3/8	BTS 8 R3/8	\$25.32	FCS 8 N3/8	\$10.88	MCS 8 R3/8	\$9.28	MES 8 R3/8	\$16.88	RTS 8 R3/8	\$25.32
10mm	R1/4	BTS 10 R1/4	\$26.80	FCS 10 R1/4	\$11.88	MCS 10 R1/4	\$8.78	MES 10 R1/4	\$17.49	RTS 10 R1/4	\$26.80
10mm	R3/8	BTS 10 R3/8	\$26.80	FCS 10 R3/8	\$12.68	MCS 10 R3/8	\$8.91	MES 10 R3/8	\$18.15	RTS 10 R3/8	\$26.80
12mm	R3/8	BTS 12 R3/8	\$29.35	FCS 12 R3/8	\$13.29	MCS 12 R3/8	\$10.76	MES 12 R3/8	\$22.31	RTS 12 R3/8	\$29.35
12mm	R1/2	BTS 12 R1/2	\$31.35	FCS 12 R1/2	\$15.29	MCS 12 R1/2	\$14.19	MES 12 R1/2	\$25.41	RTS 12 R1/2	\$31.35







# Nickel-Plated Brass Push-In Fittings List Price

Brass Fittings								
Model	Bulkhead Union		Elbow Union		Straight Union		Tee Union	
Tube OD	BUB		EUB		SUB		TUB	
1/8"	BUB 1/8	\$2.31	EUB 1/8	\$2.77	SUB 1/8	\$1.65	TUB 1/8	\$3.43
5/32"	BUB 5/32	\$2.31	EUB 5/32	\$2.77	SUB 5/32	\$1.65	TUB 5/32	\$3.43
1/4"	BUB 1/4	\$2.71	EUB 1/4	\$3.17	SUB 1/4	\$1.85	TUB 1/4	\$3.89
5/16"	BUB 5/16	\$2.77	EUB 5/16	\$3.17	SUB 5/16	\$1.85	TUB 5/16	\$4.55
3/8"	BUB 3/8	\$4.29	EUB 3/8	\$4.16	SUB 3/8	\$2.57	TUB 3/8	\$5.21
1/2"	BUB 1/2	\$4.75	EUB 1/2	\$4.49	SUB 1/2	\$3.17	TUB 1/2	\$6.07
4 mm	BUB 4	\$2.31	EUB 4	\$2.77	SUB 4	\$1.65	TUB 4	\$3.43
6 mm	BUB 6	\$2.71	EUB 6	\$3.17	SUB 6	\$1.85	TUB 6	\$3.89
8 mm	BUB 8	\$2.77	EUB 8	\$3.17	SUB 8	\$1.85	TUB 8	\$4.55

  

Brass Fittings										
Model	Branch Tee		Female Connector		Male Connector		Male Elbow, Swivel		Y Connector, Swivel	
Tube OD X Thread	BTB		FCB		MCB		MEB		YCB	
1/8" X 10-32	BTB 1/8 10-32	\$3.30	FCB 1/8 10-32	\$1.39	MCB 1/8 10-32	\$1.39	MEB 1/8 10-32	\$2.71	YCB 1/8 10-32	\$3.70
1/8" X 1/8" NPT	BTB 1/8 N1/8	\$3.30	FCB 1/8 N1/8	\$1.39	MCB 1/8 N1/8	\$1.39	MEB 1/8 N1/8	\$2.77	YCB 1/8 N1/8	\$3.70
5/32" X 10-32	BTB 5/32 10-32	\$3.30	FCB 5/32 10-32	\$1.39	MCB 5/32 10-32	\$1.39	MEB 5/32 10-32	\$2.71	YCB 5/32 10-32	\$3.70
5/32" X 1/8" NPT	BTB 5/32 N1/8	\$3.30	FCB 5/32 N1/8	\$1.39	MCB 5/32 N1/8	\$1.39	MEB 5/32 N1/8	\$2.77	YCB 5/32 N1/8	\$3.70
1/4" X 1/8" NPT	BTB 1/4 N1/8	\$3.83	FCB 1/4 N1/8	\$1.39	MCB 1/4 N1/8	\$1.39	MEB 1/4 N1/8	\$3.04	YCB 1/4 N1/8	\$4.29
1/4" X 1/4" NPT	BTB 1/4 N1/4	\$3.83	FCB 1/4 N1/4	\$1.58	MCB 1/4 N1/4	\$1.58	MEB 1/4 N1/4	\$3.30	YCB 1/4 N1/4	\$4.29
1/4" X 3/8" NPT	BTB 1/4 N3/8	\$3.83	FCB 1/4 N3/8	\$1.85	MCB 1/4 N3/8	\$1.85	MEB 1/4 N3/8	\$3.63	YCB 1/4 N3/8	\$4.49
5/16" X 1/4" NPT	BTB 5/16 N1/4	\$3.83	FCB 5/16 N1/4	\$1.78	MCB 5/16 N1/4	\$1.78	MEB 5/16 N1/4	\$4.10	YCB 5/16 N1/4	
5/16" X 3/8" NPT	BTB 5/16 N3/8	\$4.95	FCB 5/16 N3/8	\$1.91	MCB 5/16 N3/8	\$1.91	MEB 5/16 N3/8	\$4.16	YCB 5/16 N3/8	
3/8" X 1/4" NPT	BTB 3/8 N1/4	\$4.95	FCB 3/8 N1/4	\$2.05	MCB 3/8 N1/4	\$2.05	MEB 3/8 N1/4	\$4.49	YCB 3/8 N1/4	\$5.61
3/8" X 3/8" NPT	BTB 3/8 N3/8	\$4.95	FCB 3/8 N3/8	\$2.18	MCB 3/8 N3/8	\$2.18	MEB 3/8 N3/8	\$4.62	YCB 3/8 N3/8	\$5.68
3/8" X 1/2" NPT	BTB 3/8 N1/2	\$5.15	FCB 3/8 N1/2	\$2.90	MCB 3/8 N1/2	\$2.90	MEB 3/8 N1/2	\$5.15	YCB 3/8 N1/2	\$5.94
1/2" X 3/8" NPT	BTB 1/2 N3/8	\$5.02	FCB 1/2 N3/8	\$2.31	MCB 1/2 N3/8	\$2.31	MEB 1/2 N3/8	\$5.02	YCB 1/2 N3/8	
1/2" X 1/2" NPT	BTB 1/2 N1/2	\$5.41	FCB 1/2 N1/2	\$3.17	MCB 1/2 N1/2	\$3.17	MEB 1/2 N1/2	\$5.41	YCB 1/2 N1/2	
4 mm X M5	BTB 4 M5	\$3.30	FCB 4 M5	\$1.19	MCB 4 M5	\$1.19	MEB 4 M5	\$2.71	YCB 4 M5	\$3.70
4 X 1/8" NPT	BTB 4 N1/8	\$3.30	FCB 4 N1/8	\$1.19	MCB 4 N1/8	\$1.19	MEB 4 N1/8	\$2.77	YCB 4 N1/8	\$3.70
8 mm X 1/4" NPT	BTB 8 N1/4	\$3.83	FCB 8 N1/4	\$1.78	MCB 8 N1/4	\$1.78	MEB 8 N1/4	\$4.10	YCB 8 N1/4	
8 mm X 3/8" NPT	BTB 8 N3/8	\$4.95	FCB 8 N3/8	\$1.91	MCB 8 N3/8	\$1.91	MEB 8 N3/8	\$4.16	YCB 8 N3/8	

Metal Fittings														
Model	Quick Exhaust		Shuttle Valve		In-line Flow Control		In-line Flow Control		Speed Control Muffler		Muffler		Union Valve	
Port	QE		ST		ASC		AS		BESL		BSL		UV	
10-32					ASC 10-32	\$12.87			BESL 10-32	\$2.51	BSL 10-32	\$0.65		
1/8	QE N1/8	\$13.66	ST N1/8	\$13.66	ASC N1/8	\$12.87	AS N1/8	\$8.27	BESL N1/8	\$3.50	BSL N1/8	\$0.95	UV 1/4-1/4	\$11.66
1/4	QE N1/4	\$15.44	ST N1/4	\$15.44	ASC N1/4	\$12.87	AS N1/4	\$8.27	BESL N1/4	\$4.95	BSL N1/4	\$0.1.85	UV 6-6	\$11.66
3/8	QE N3/8	\$15.44	ST N3/8	\$15.44	ASC N3/8	\$14.85	AS N3/8	\$9.90	BESL N3/8	\$7.60	BSL N3/8	\$2.80		
1/2	QE N1/2	\$17.60	ST N1/2	\$17.60	ASC N1/2	\$17.82	AS N1/2	\$15.50	BESL N1/2	\$10.45	BSL N1/2	\$4.30		
3/4	QE N3/4	\$41.80	ST N3/4	\$41.80										

# Composite, Stainless Steel, & Nickel-Plated Brass Push-In Fittings Specifications

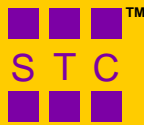

## A. Installation of Pipe Fittings:

1. Tighten fitting by hand, then turn it 2-3 turns with a wrench until it reaches the desire torque listed. If the fitting is not pre-coated with sealant, or is used and the sealant is not in good condition, apply Teflon sealant tape to the threads.

Recommendation of Torque for Tightening Fittings		
Fitting Thread Size	Torque, lb-ft	Torque, kgf/cm
10-32, M5 -M6	1.0 -1.5	14 -21
NPT1/8, R1/8	5 -6.5	70 -90
NPT1/4, R1/4	8.5 -10	120 -140
NPT3/8, R3/8	16 -17.5	220 -240
NPT1/2, R1/2	20 -21.5	280 -300

## B. Installation of Tubing into Fitting:

1. Slowly push a clean and perpendicularly cut tubing into the fitting until it comes to a dead stop.
2. Pull the tubing back gently until the Grip Ring or Collet of the fitting grips onto the tubing and has a good seal.
3. Use Polyethylene, Polypropylene, Polyurethane or Nylon Tubing designed for instant fittings.
4. Hard metal tubing can be used for all metal Stainless Steel and all Brass fittings if the tubing is pre-grooved.

## C. Removal of Tubing from Fitting:

1. Push in evenly on the two long oval sides of the Release Button.
2. Pull out the tube while depressing the Release Button.
3. To reuse the tubing, cut off the lodged portion of the previously used tubing in an even and perpendicular fashion.

## D. Recommended Tubing Material, Size and Hardness Requirements:

Tubing Material	Specified Size	Hardness (Durometer)
Polyurethane	+/- 0.006" (+/-0.15 mm)	Shore A 85 or higher
Polyethylene	+/- 0.004" (+/-0.1 mm)	Shore D 44 or higher
Polypropylene	+/- 0.004" (+/-0.1 mm)	Shore D 44 or higher
Nylon	+/- 0.004" (+/-0.1 mm)	Shore D 44 or higher
Pre-grooved Metal Tubing	+/- 0.004" (+/-0.1 mm)	

## E. Specifications, Materials of Construction and Schematic of Typical Construction:

	Composite Fittings		Stainless Steel Fittings	Nickel-Plated Brass Fittings
	(Standard-Purple Button)	(K Series-Black Button)		
Operating Pressure Range	0 - 150 PSI (0 - 990 kpa)	0 - 180 PSI (0 - 1200 kpa)	0 - 250 PSI (0 - 1650 kpa)	0 - 250 PSI (0 - 1650 kpa)
Vacuum	0 - 29.5 in Hg (750 mm Hg)		0 - 30 in Hg (760 mm) Hg	0 - 30 in Hg (760 mm) Hg
Operating Temperature	32 - 140 °F (0 - 60 °C)		5 - 230 °F (-15 to 110 °C)	5 - 230 °F (-15 to 110 °C)
Recommended Tubing Material	Polyurethane, Nylon, Polyethylene, Polypropylene		Polyurethane, Nylon, Polyethylene, Polypropylene, and Hard metal tubing (tubing must be pre-grooved)	
Metal Body	Brass, Nickel Plated		T316 Stainless Steel	Nickel-Plated Brass
Plastic Body	PBT (Polybutylene terephthalate)		None	None
Release Button	POM (Poly oxy methylene copolymer)		300 series Stainless Steel	Nickel-Plated Brass
Grip Ring or Collet	300 series Stainless Steel		300 series Stainless Steel	300 series Stainless Steel
O-ring	NBR (Buna-N)		VITON	NBR/VITON/EPDM
Thread Sealant	Teflon		None	Teflon
Service	FOR AIR ONLY		Air, Liquid	Air, Liquid

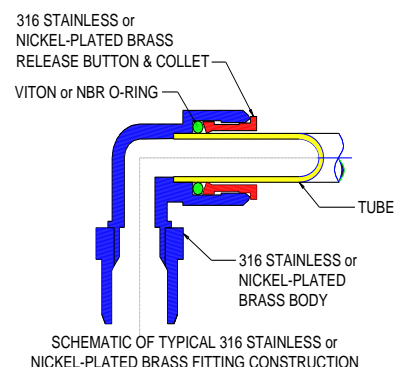
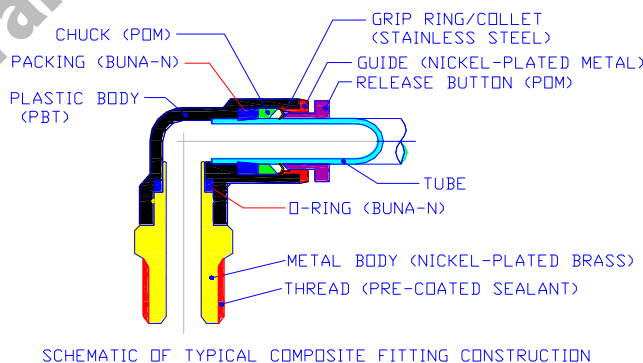

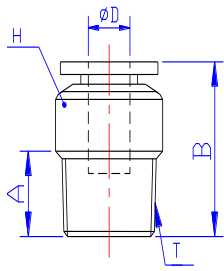

Compact Male Connector, CC

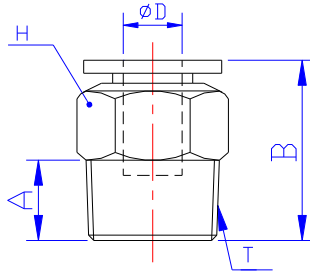

Male Connector, MC

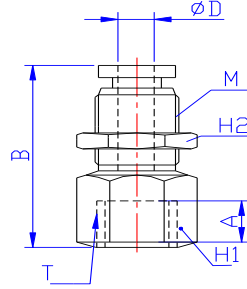

Bulkhead Connector, BC

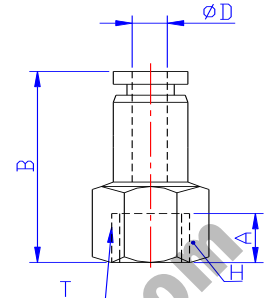

Female Connector, FC

ØD	T	Model	A	B	H	Model	A	B	H	Model	M	A	H1	H2	B	Model	A	B	H
5/32	10-32UNF	CC 5/32 10-32	3.8	20.3	Ø10.0	MC 5/32 10-32	3.8	20.3	11.1										
5/32	NPT1/8	CC 5/32 N1/8	7.5	19.8	Ø10.0	MC 5/32 N1/8	7.5	19.8	11.1	BC 5/32 N1/8	M12	7.5	14.3	14.3	23.8	FC 5/32 N1/8	7.5	23.8	14.3
5/32	NPT1/4	CC 5/32 N1/4				MC 5/32 N1/4	10.5	18.9	14.3							FC 5/32 N1/4	10.5	26.8	17.4
3/16	10-32UNF	CC 3/16 10-32				MC 3/16 10-32	3.8	20.9	11.1										
3/16	NPT1/8	CC 3/16 N1/8				MC 3/16 N1/8	7.5	20.6	11.1	BC 3/16 N1/8	M14	7.5	14.3	17.4	24.7	FC 3/16 N1/8	7.5	24.4	14.3
3/16	NPT1/4	CC 3/16 N1/4				MC 3/16 N1/4	10.5	23.7	14.3	BC 3/16 N1/4	M14	10.5	17.4	17.4	30.4	FC 3/16 N1/4	10.5	27.4	17.4
3/16	NPT3/8	CC 3/16 N3/8				MC 3/16 N3/8	11	21.2	17.4										
1/4	10-32UNF	CC 1/4 10-32	3.8	21.2	Ø12.0	MC 1/4 10-32	3.8	21.2	12.7										
1/4	NPT1/8	CC 1/4 N1/8	7.5	20.9	Ø12.0	MC 1/4 N1/8	7.5	20.9	12.7	BC 1/4 N1/8	M14	7.5	17.4	17.4	24.7	FC 1/4 N1/8	7.5	24.9	14.3
1/4	NPT1/4	CC 1/4 N1/4	10.5	23.7	Ø14.0	MC 1/4 N1/4	10.5	23.7	14.3	BC 1/4 N1/4	M14	10.5	17.4	17.4	30.4	FC 1/4 N1/4	10.5	27.9	17.4
1/4	NPT3/8	CC 1/4 N3/8				MC 1/4 N3/8	11	21.2	17.4										
5/16	NPT1/8	CC 5/16 N1/8	7.5	25.9	Ø14.0	MC 5/16 N1/8	7.5	25.9	14.3	BC 5/16 N1/8	M16	7.5	19	19	27.9	FC 5/16 N1/8	7.5	26.4	14.3
5/16	NPT1/4	CC 5/16 N1/4	10.5	25.9	Ø14.0	MC 5/16 N1/4	10.5	25.9	14.3	BC 5/16 N1/4	M16	10.5	19	19	35.9	FC 5/16 N1/4	10.5	29.4	17.4
5/16	NPT3/8	CC 5/16 N3/8	11	22.4	Ø17.0	MC 5/16 N3/8	11	22.4	17.4	BC 5/16 N3/8	M16	11	19	19	35.4	FC 5/16 N3/8	11	29.9	22.2
3/8	NPT1/8	CC 3/8 N1/8				MC 3/8 N1/8	7.5	28.2	17.4										
3/8	NPT1/4	CC 3/8 N1/4	10.5	30.5	Ø17.0	MC 3/8 N1/4	10.5	30.5	17.4	BC 3/8 N1/4	M20	10.5	22.2	22.2	31.9	FC 3/8 N1/4			
3/8	NPT3/8	CC 3/8 N3/8	11	27.5	Ø17.0	MC 3/8 N3/8	11	27.5	17.4	BC 3/8 N3/8	M20	11	22.2	22.2	34.7	FC 3/8 N3/8			
3/8	NPT1/2	CC 3/8 N1/2	14	25.8	Ø21.0	MC 3/8 N1/2	14	25.8	22.2										
1/2	NPT1/4	CC 1/2 N1/4	10.5	33.9	Ø21.0	MC 1/2 N1/4	10.5	33.9	22.2							FC 1/2 N1/4			
1/2	NPT3/8	CC 1/2 N3/8	11	30.4	Ø21.0	MC 1/2 N3/8	11	30.4	22.2	BC 1/2 N3/8	M22	11	25.4	25.4	35.4	FC 1/2 N3/8			
1/2	NPT1/2	CC 1/2 N1/2	14	33.4	Ø21.0	MC 1/2 N1/2	14	33.4	22.2	BC 1/2 N1/2	M22	14	25.4	25.4	41.4				

Tube OD	T	Model	B	H	Model	B	H	Model	H1	H2	B	Model	B	H
4	M5	CC 4 M5	22.8	10	MC 4 M5	22.8	10							
4	M6	CC 4 M6	24.3	10	MC 4 M6	24.3	10							
4	R1/8	CC 4 R1/8	20.9	10	MC 4 R1/8	20.9	10	BC 4 R1/8	14	14	27.5	FC 4 1/8	27.5	12
4	R1/4	CC 4 R1/4	23.6	14	MC 4 R1/4	23.6	14	BC 4 R1/4	19	14	30.1	FC 4 R1/4	30.1	17
6	M5	CC 6 M5	24.1	12	MC 6 M5	24.1	12							
6	M6	CC 6 M6	25.8	12	MC 6 M6	25.8	12							
6	R1/8	CC 6 R1/8	22.3	12	MC 6 R1/8	22.3	12	BC 6 R1/8	17	17	28.8	FC 6 R1/8	28.8	14
6	R1/4	CC 6 R1/4	22.2	14	MC 6 R1/4	22.2	14	BC 6 R1/4	17	17	29.2	FC 6 R1/4	29.2	17
6	R3/8	CC 6 R3/8	24.1	17	MC 6 R3/8	24.1	17	BC 6 R3/8	19	17	31.2	FC 6 R3/8	31.2	19
6	R1/2	CC 6 R1/2	28.4	21	MC 6 R1/2	28.4	21							
8	R1/8	CC 8 R1/8	26.2	14	MC 8 R1/8	26.2	14	BC 8 R1/8	17	19	29.6	FC 8 R1/8	29.6	10
8	R1/4	CC 8 R1/4	25.7	14	MC 8 R1/4	25.7	14	BC 8 R1/4	17	19	30.5	FC 8 R1/4	30.5	17
8	R3/8	CC 8 R3/8	28.1	17	MC 8 R3/8	28.1	17	BC 8 R3/8	19	19	31.7	FC 8 R3/8	31.7	19
8	R1/2	CC 8 R1/2	28.0	21	MC 8 R1/2	28.0	21	BC 8 R1/2	24	19	36.8	FC 8 R1/2	36.8	24
10	R1/8	CC 10 R1/8	28.5	17	MC 10 R1/8	28.5	17	BC 10 R1/8	21	24	31.5	FC 10 R1/8	31.5	19
10	R1/4	CC 10 R1/4	30.0	17	MC 10 R1/4	30.0	17	BC 10 R1/4	21	24	32.7	FC 10 R1/4	32.7	19
10	R3/8	CC 10 R3/8	30.8	17	MC 10 R3/8	30.8	17	BC 10 R3/8	21	24	38.4	FC 10 R3/8	38.4	19
10	R1/2	CC 10 R1/2	29.6	21	MC 10 R1/2	29.6	21	BC 10 R1/2	24	24	38.4	FC 10 R1/2	38.4	24
12	R1/4	CC 12 R1/4	34.7	19	MC 12 R1/4	34.7	19	BC 12 R1/4	24	26	33.2	FC 12 R1/4	33.2	21
12	R3/8	CC 12 R3/8	30.5	19	MC 12 R3/8	30.5	19	BC 12 R3/8	24	26	37.0	FC 12 R3/8	37.0	21
12	R1/2	CC 12 R1/2	29.9	21	MC 12 R1/2	29.9	21	BC 12 R1/2	24	26	37.7	FC 12 R1/2	37.7	24

Units in mm

# Composite Push-In Air Fittings Dimensions

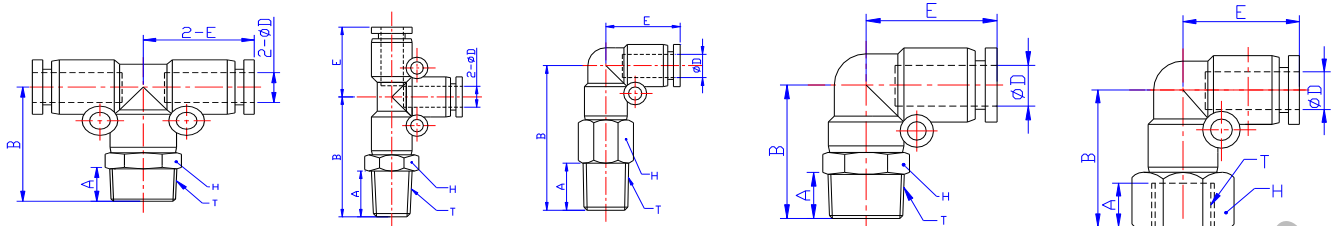

Branch Tee, BT

Run Tee, RT

Extended Elbow, EE

Male Elbow, ME

Female Elbow, FE

ΦD	T	A	H	Model	Model	B	E	Model	B	E	Model	B	E	Model	B	E	H
5/32	10-32UNF	3.8	11.1	BT 5/32 10-32	RT 5/32 10-32	23	18.5	EE5/32 10-32	33.5	17.5	ME 5/32 10-32	22	17.5	FE 5/32 10-32			
5/32	NPT1/8	7.5	11.1	BT 5/32 N1/8	RT 5/32 N1/8	25	18.5	EE 5/32 N1/8	36	17.5	ME 5/32 N1/8	24	17.5	FE 5/32 N1/8	23.5	17.5	14.3
5/32	NPT1/4	10.5	14.3	BT 5/32 N1/4	RT 5/32 N1/4	29	18.5				ME 5/32 N1/4	28	17.5	FE 5/32 N1/4			
3/16	10-32UNF	3.8	11.1	BT 3/16 10-32	RT 3/16 10-32	23	18.8				ME 3/16 10-32	22	17.8	FE 3/16 10-32			
3/16	NPT1/8	7.5	11.1	BT 3/16 N1/8	RT 3/16 N1/8	25.5	18.8	EE 3/16 N1/8	36	17.8	ME 3/16 N1/8	24.5	17.8	FE 3/16 N1/8	23.8	17.8	14.3
3/16	NPT1/4	10.5	14.3	BT 3/16 N1/4	RT 3/16 N1/4	29	18.8	EE 3/16 N1/4	39.5	17.8	ME 3/16 N1/4	28	17.8	FE 3/16 N1/4	26.5	17.8	17.4
3/16	NPT3/8	11	17.4	BT 3/16 N3/8	RT 3/16 N3/8	30	18.8	EE 3/16 N3/8	40.5	17.8	ME 3/16 N3/8	29	17.8				
1/4	10-32UNF	3.8	12.7	BT 1/4 10-32	RT 1/4 10-32	24.7	19.3				ME 1/4 10-32	24.4	19	FE 1/4 10-32			
1/4	NPT1/8	7.5	12.7	BT 1/4 N1/8	RT 1/4 N1/8	26	19.3	EE 1/4 N1/8	39.7	19	ME 1/4 N1/8	25.7	19	FE 1/4 N1/8	24.9	19	14.3
1/4	NPT1/4	10.5	14.3	BT 1/4 N1/4	RT 1/4 N1/4	29.5	19.3	EE 1/4 N1/4	43.2	19	ME 1/4 N1/4	29.2	19	FE 1/4 N1/4	27.9	19	17.4
1/4	NPT3/8	11	17.4	BT 1/4 N3/8	RT 1/4 N3/8	30.5	19.3	EE 1/4 N3/8	44.2	19	ME 1/4 N3/8	30.2	19	FE 1/4 N3/8			
5/16	NPT1/8	7.5	14.3	BT 5/16 N1/8	RT 5/16 N1/8	29.45	22.75	EE 5/16 N1/8	44.8	22.8	ME 5/16 N1/8	29.5	22.8	FE 5/16 N1/8	27.5	22.8	14.3
5/16	NPT1/4	10.5	14.3	BT 5/16 N1/4	RT 5/16 N1/4	32.45	22.75	EE 5/16 N1/4	47.8	22.8	ME 5/16 N1/4	32.5	22.8	FE 5/16 N1/4	31	22.8	17.4
5/16	NPT3/8	11	17.4	BT 5/16 N3/8	RT 5/16 N3/8	33.45	22.75	EE 5/16 N3/8	48.8	22.8	ME 5/16 N3/8	33.5	22.8	FE 5/16 N3/8	32	22.8	22.2
3/8	NPT1/8	7.5	17.4	BT 3/8 N1/8	RT 3/8 N1/8	35	27				ME 3/8 N1/8	34.3	26.3				
3/8	NPT1/4	10.5	17.4	BT 3/8 N1/4	RT 3/8 N1/4	38	27	EE 3/8 N1/4	56.3	26.3	ME 3/8 N1/4	37.3	26.3	FE 3/8 N1/4	35.3	26.3	17.4
3/8	NPT3/8	11	17.4	BT 3/8 N3/8	RT 3/8 N3/8	38.5	27	EE 3/8 N3/8	57.8	26.3	ME 3/8 N3/8	37.8	26.3	FE 3/8 N3/8	35.8	26.3	22.2
3/8	NPT1/2	14	22.2	BT 3/8 N1/2	RT 3/8 N1/2	42	27	EE 3/8 N1/2	61.3	26.3	ME 3/8 N1/2	41.3	26.3	FE 3/8 N1/2			
1/2	NPT1/4	10.5	22.2	BT 1/2 N1/4	RT 1/2 N1/4	39.5	29.6	EE 1/2 N1/4	62.5	29.6	ME 1/2 N1/4	39.5	29.6				
1/2	NPT3/8	11	22.2	BT 1/2 N3/8	RT 1/2 N3/8	40	29.6	EE 1/2 N3/8	63	29.6	ME 1/2 N3/8	40	29.6	FE 1/2-N3/8	37.5	29.6	22.2
1/2	NPT1/2	14	22.2	BT 1/2 N1/2	RT 1/2 N1/2	43	29.6	EE 1/2 N1/2	66	29.6	ME 1/2 N1/2	43	29.6	FE 1/2-N1/2	40.5	29.6	25.4

ΦD	Pipe Size	E	Model	Model	B	H	Model	B1	H	Model	B	H	Model	B2	H2
4	M5	18.1	BT 4 M5	RT 4 M5	23.0	10	EE 4 M5	36.1	10	ME 4 M5	23.0	10	FE 4 M5	20.9	10
4	M6	18.1	BT 4 M6	RT 4 M6	22.4	10	EE 4 M6	35.2	10	ME 4 M6	22.4	10	FE 4 M6	20.7	10
4	R1/8	18.1	BT 4 R1/8	RT 4 R1/8	26.1	10	EE 4 R1/8	36.8	10	ME 4 R1/8	26.1	10	FE 4 R1/8	22.3	12
4	R1/4	18.1	BT 4 R1/4	RT 4 R1/4	27.7	14	EE 4 R1/4	36.4	14	ME 4 R1/4	27.7	14	FE 4 R1/4	28.1	17
6	M5	21.1	BT 6 M5	RT 6 M5	25.8	12	EE 6 M5	39.0	12	ME 6 M5	25.8	12	FE 6 M5	23.0	12
6	M6	21.1	BT 6 M6	RT 6 M6	26.4	12	EE 6 M6	39.6	12	ME 6 M6	26.4	12	FE 6 M6	23.1	12
6	R1/8	21.1	BT 6 R1/8	RT 6 R1/8	28.1	12	EE 6 R1/8	38.8	12	ME 6 R1/8	28.1	12	FE 6 R1/8	26.0	14
6	R1/4	21.1	BT 6 R1/4	RT 6 R1/4	29.2	14	EE 6 R1/4	45.0	14	ME 6 R1/4	29.2	14	FE 6 R1/4	28.5	17
6	R3/8	21.1	BT 6 R3/8	RT 6 R3/8	31.7	17	EE 6 R3/8	44.9	17	ME 6 R3/8	31.7	17	FE 6 R3/8	33.4	19
6	R1/2	21.1	BT 6 R1/2	RT 6 R1/2	34.9	21	EE 6 R1/2	48.1	21	ME 6 R1/2	34.9	21			
8	R1/8	23.1	BT 8 R1/8	RT 8 R1/8	30.1	14	EE 8 R1/8	42.2	14	ME 8 R1/8	30.1	14			
8	R1/4	23.1	BT 8 R1/4	RT 8 R1/4	30.8	14	EE 8 R1/4	46.7	14	ME 8 R1/4	30.8	14	FE 8 R1/8	28.6	14
8	R3/8	23.1	BT 8 R3/8	RT 8 R3/8	33.6	17	EE 8 R3/8	46.5	17	ME 8 R3/8	33.6	17	FE 8 R1/4	30.0	17
8	R1/2	23.1	BT 8 R1/2	RT 8 R1/2	35.2	21	EE 8 R1/2	52.7	21	ME 8 R1/2	35.2	21	FE 10 R1/8	30.7	17
10	R1/8	27.9	BT 10 R1/8	RT 10 R1/8	32.6	17	EE 10 R1/8	53.1	17	ME 10 R1/8	32.6	17			
10	R1/4	27.9	BT 10 R1/4	RT 10 R1/4	35.1	17	EE 10 R1/4	56.3	17	ME 10 R1/4	35.1	17	FE 10 R1/4	31.1	17
10	R3/8	27.9	BT 10 R3/8	RT 10 R3/8	36.6	17	EE 10 R3/8	57.0	17	ME 10 R3/8	36.6	17	FE 10 R3/8	34.4	19
10	R1/2	27.9	BT 10 R1/2	RT 10 R1/2	38.6	21	EE 10 R1/2		21	ME 10 R1/2	38.6	21	FE 10 R1/2	37.8	24
12	R1/4	28.3	BT 12 R1/4	RT 12 R1/4	35.2	19	EE 12 R1/4	62.6	19	ME 12 R1/4	35.2	19	FE 12 R1/4	36.4	19
12	R3/8	28.3	BT 12 R3/8	RT 12 R3/8	37.5	19	EE 12 R3/8	62.9	19	ME 12 R3/8	37.5	19	FE 12 R3/8	39.0	19
12	R1/2	28.3	BT 12 R1/2	RT 12 R1/2	39.8	21	EE 12 R1/2		21	ME 12 R1/2	39.8	21	FE 12 R1/2	42.8	24

Units in mm



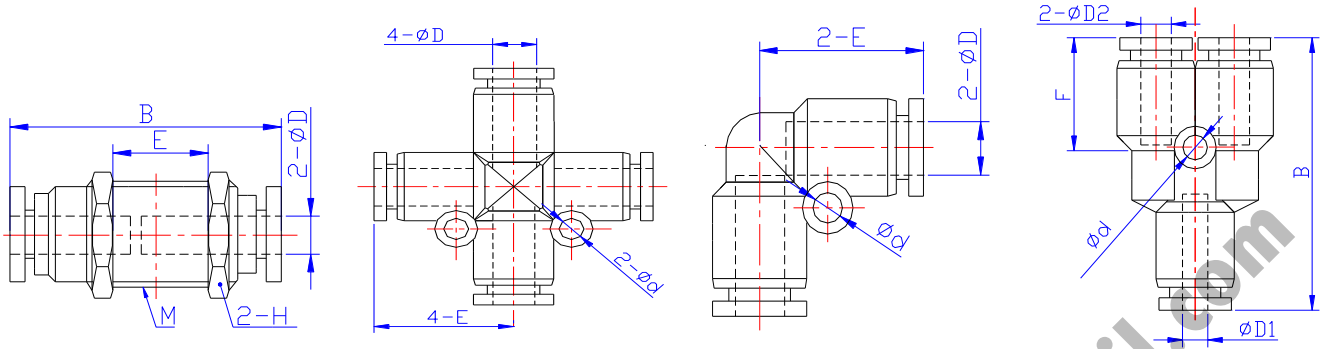

Bulkhead Union, BU

Cross Union, CU

Elbow Union, EU

Reduced Branch, RB

∅D	Model	B	E	H	M	Model	∅d	E	Model	E	∅d	Model	∅D1	∅D2	∅d	B	F
5/32	BU 5/32	30.1	9.7	14.3	M12	CU 5/32	3.2	17.5	EU 5/32	17.5	3.2	RB 3/16-5/32	3/16	5/32	3.2	35.8	14.0
3/16	BU 3/16	31.8	7.5	17.4	M14	CU 3/16	3.2	17.8	EU 3/16	17.8	3.2	RB 1/4-5/32	1/4	5/32	3.2	36.8	14.5
1/4	BU 1/4	31.8	7.5	17.4	M14	CU 1/4	3.2	19.3	EU 1/4	19	3.2	RB 1/4-3/16	1/4	3/16	3.2	37.1	14.8
5/16	BU 5/16	35.3	6.8	19.0	M16	CU 5/16	3.2	22.75	EU 5/16	22.8	3.2	RB 5/16-1/4	5/16	1/4	3.2	39.9	17.7
3/8	BU 3/8	36.4	8.9	22.2	M20	CU 3/8	4.2	27	EU 3/8	26.3	4.2	RB 3/8-1/4					
1/2	BU 1/2	45.3	12.8	25.4	M22	CU 1/2	4.3	29.6	EU 1/2	29.6	4.3	RB 3/8-5/16	3/8	5/16	4.2	47.9	20.3
												RB 1/2-3/8	1/2	3/8	4.2	51.6	20.0
4	BU 4	35.2	13.4	14.0	12.0	CU 4	2.0	18.2	EU 4	18.2	3.0						
6	BU 6	35.4	14.3	17.0	14.0	CU 6	3.0	21.0	EU 6	21.0	3.0	RB 6-4		10.5	2.0	36.7	14.5
8	BU 8	41.1	16.2	19.0	16.0	CU 8	3.0	23.0	EU 8	23.0	3.0	RB 8-6		13.2	3.0	42.4	17.2
10	BU 10	44.7	16.6	24.0	20.0	CU 10	3.0	27.4	EU 10	27.4	3.0	RB 10-8		14.8	4.0	50.2	20.1
12	BU 12	45.3	16.6	26.0	22.0	CU 12	2.5	27.4	EU 12	27.4	3.0	RB 12-10		18.4	4.0	54.6	22.4

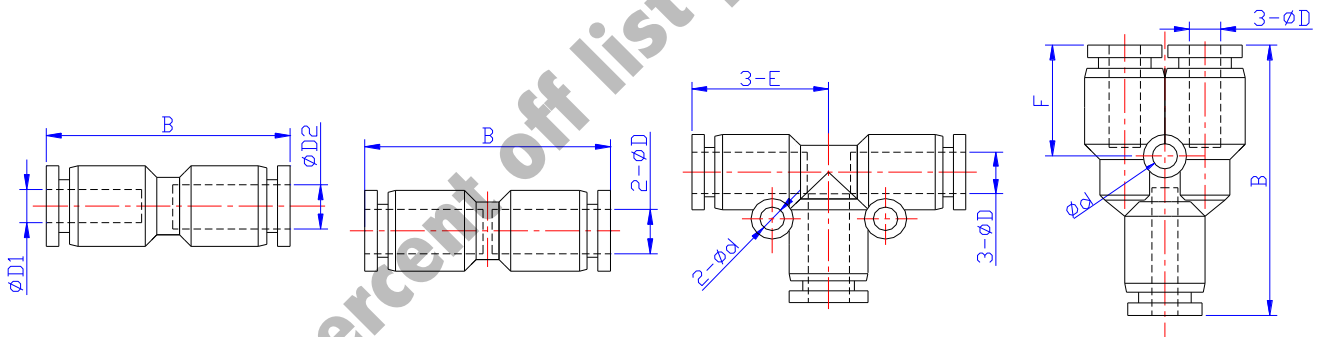

Reduced Union, RU

Straight Union, SU

Tee Union, TU

Y Union, YU

Part No.	∅D1	∅D2	B	Part No.	∅D	B	Part No.	∅D	∅d	E	Part No.	∅D	∅d	B	F
RU 3/16-5/32	3/16	5/32	33.3	SU 5/32	5/32	33	TU 5/32	5/32	3.2	18.5	YU 5/32	5/32	3.2	35.5	14.0
RU 1/4-5/32	1/4	5/32	34.9	SU 3/16	3/16	33.6	TU 3/16	3/16	3.2	18.8	YU 3/16	3/16	3.2	36.1	14.3
RU 1/4-3/16	1/4	3/16	35.2	SU 1/4	1/4	35.2	TU 1/4	1/4	3.2	19.3	YU 1/4	1/4	3.2	37.1	14.8
RU 5/16-1/4	5/16	1/4	38.6	SU 5/16	5/16	39.1	TU 5/16	5/16	3.2	22.75	YU 5/16	5/16	3.2	40.4	18.2
RU 3/8-1/4				SU 3/8	3/8	45.2	TU 3/8	3/8	4.2	27	YU 3/8	3/8	4.2	47.1	19.5
RU 3/8-5/16	3/8	5/16	47.3	SU 1/2	1/2	49.2	TU 1/2	1/2	4.3	29.6	YU 1/2	1/2	4.2	53.2	21.6
RU 1/2-3/8	1/2	3/8	48.9												
RU 6-4	4	6	33.9	SU 4		30.8	TU 4		3	18.2	YU 4		3	33.5	14.9
RU 8-6	6	8	38.7	SU 6		37.6	TU 6		3	21	YU 6		3	37	15.8
RU 10-8	8	10	42.5	SU 8		39.5	TU 8		3	23	YU 8		3	38.4	16
RU 12-10	10	12	47.4	SU 10		47.1	TU 10		3	27.4	YU 10		4	52.1	19.1
				SU 12		50.3	TU 12		3	27.4	YU 12		4	54.8	21.6

Units in mm

# Composite Push-In Air Fittings Dimensions

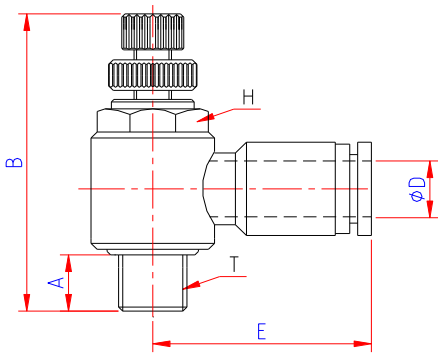

CV = Air Control Valve (meter-out)  
CI = Air Control Valve (meter-in)

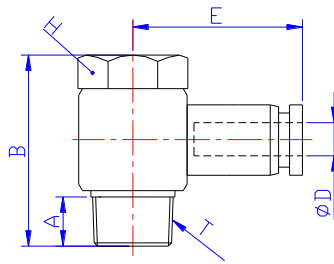

Universal Elbow, UE

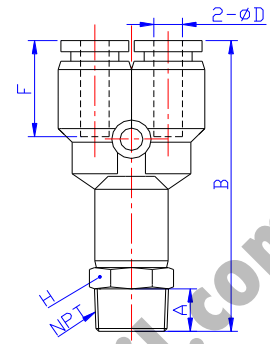

Y Connector, YC

ØD	T	A	H	Model (CV/CI)	B	E	Model	B	E	Part No.	A	B	F	H
5/32	10-32	3.8	8	CV 5/32 10-32	29.3	20	UE 5/32 10-32	17	20	YC 5/32 10-32	3.8	40	14	11.1
5/32	NPT1/8	7.5	11.1	CV 5/32 N1/8	40.1	22.6	UE 5/32 N1/8	23.5	22.3	YC 5/32 N1/8	7.5	42	14	11.1
5/32	NPT1/4									YC 5/32 N1/4	10.5	46	14	14.3
3/16	10-32	3.8	8				UE 3/16 10-32	17	20.3	YC 3/16 10-32	3.8	40.3	14.3	11.1
3/16	NPT1/8	7.5	11.1				UE 3/16 N1/8	23.5	22.6	YC 3/16 N1/8	7.5	42.8	14.3	11.1
3/16	NPT1/4	10.5	14.3				UE 3/16 N1/4	27.3	24.3	YC 3/16 N1/4	10.5	46.3	14.3	14.3
3/16	NPT3/8									YC 3/16 N3/8	11	47.3	14.3	17.4
1/4	10-32	3.8	8	CV 1/4 10-32	29.3	22				YC 1/4 10-32	3.8	42.5	14.8	12.7
1/4	NPT1/8	7.5	11.1	CV 1/4 N1/8	40.1	23.1	UE 1/4 N1/8	23.5	23.1	YC 1/4 N1/8	7.5	43.8	14.8	12.7
1/4	NPT1/4	10.5	14.3	CV 1/4 N1/4	47.2	25.1	UE 1/4 N1/4	27.3	25.1	YC 1/4 N1/4	10.5	47.3	14.8	14.3
1/4	NPT3/8	11	19	CV 1/4 N3/8	53.9	26.8				YC 1/4 N3/8	11	48.3	14.8	17.4
5/16	NPT1/8	7.5	11.1	CV 5/16 N1/8	40.1	25.6	UE 5/16 N1/8	23.5	25.6	YC 5/16 N1/8	7.5	47.1	18.2	14.3
5/16	NPT1/4	10.5	14.3	CV 5/16 N1/4	47.2	28.6	UE 5/16 N1/4	27.3	28.6	YC 5/16 N1/4	10.5	50.1	18.2	14.3
5/16	NPT3/8	11	19	CV 5/16 N3/8	53.9	29.6	UE 5/16 N3/8	32.4	29.6	YC 5/16 N3/8	11	51.1	18.2	17.4
3/8	NPT1/8									YC 3/8 N1/8	7.5	55.1	19.5	17.4
3/8	NPT1/4	10.5	14.3	CV 3/8 N1/4	47.2	31	UE 3/8 N1/4	27.3	31	YC 3/8 N1/4	10.5	58.1	19.5	17.4
3/8	NPT3/8	11	19	CV 3/8 N3/8	53.9	31.6	UE 3/8 N3/8	32.4	31.6	YC 3/8 N3/8	11	58.6	19.5	17.4
3/8	NPT1/2	14	25.4	CV 3/8 N1/2	58.4	34.6				YC 3/8 N1/2	14	62.1	19.5	22.2
1/2	NPT1/4									YC 1/2 N1/4	10.5	63.1	21.6	22.2
1/2	NPT3/8	11	19	CV 1/2 N3/8	53.9	35.6	UE 1/2 N3/8	32.4	35.6	YC 1/2 N3/8	11	63.6	21.6	22.2
1/2	NPT1/2	14	25.4	CV 1/2 N1/2	58.4	36.6	UE 1/2 N1/2	39.1	36.6	YC 1/2 N1/2	14	66.6	21.6	22.2

ØD	T	H	Model (CV/CI)	E	Model	Model	B	F	H
4	M5	8	CV 4 M5	20.7	UE 4 M5	YC 4 M5	38.8	13.8	10
4	M6	8	CV 4 M6	20.6	UE 4 M6	YC 4 M6	38.5	13.9	10
4	R1/8	10	CV 4 R1/8	22.2	UE 4 R1/8	YC 4 R1/8	40.1	14.3	10
4	R1/4	14	CV 4 R1/4	27.3	UE 4 R1/4	YC 4 R1/4	42.5	13.9	14
6	M5	8	CV 6 M5	23.1	UE 6 M5	YC 6 M5	41.6	15.5	12
6	M6	8	CV 6 M6	23.8	UE 6 M6	YC 6 M6	42.8	15.3	12
6	R1/8	10	CV 6 R1/8	23.6	UE 6 R1/8	YC 6 R1/8	44.3	15.5	12
6	R1/4	14	CV 6 R1/4	25.5	UE 6 R1/4	YC 6 R1/4	44.8	15.3	14
6	R3/8	19	CV 6 R3/8	27.8	UE 6 R3/8	YC 6 R3/8	47.6	15.4	17
6	R1/2					YC 6 R1/2	50.6	15.1	21
8	R1/8	10	CV 8 R1/8	26.5	UE 8 R1/8	YC 8 R1/8	45.4	16.9	14
8	R1/4	14	CV 8 R1/4	27.8	UE 8 R1/4	YC 8 R1/4	46.4	16.9	14
8	R3/8	19	CV 8 R3/8	31.4	UE 8 R3/8	YC 8 R3/8	48.3	15.7	17
8	R1/2	24	CV 8 R1/2	30.3	UE 8 R1/2	YC 8 R1/2	50.5	17.1	21
10	R1/8					YC 10 R1/8	57.0	21.0	17
10	R1/4	14	CV 10 R1/4	34.0	UE 10 R1/4	YC 10 R1/4	59.3	21.2	17
10	R3/8	19	CV 10 R3/8	33.4	UE 10 R3/8	YC 10 R3/8	60.5	20.0	17
10	R1/2	24	CV 10 R1/2	35.2	UE 10 R1/2	YC 10 R1/2	62.9	21.4	21
12	R1/4	14	CV 12 R1/4	34.2	UE 12 R1/4	YC 12 R1/4	61.4	21.9	19
12	R3/8	19	CV 12 R3/8	34.2	UE 12 R3/8	YC 12 R3/8	63.4	21.8	19
12	R1/2	24	CV 12 R1/2	37.2	UE 12 R1/2	YC 12 R1/2	65.5	21.8	21

Units in mm

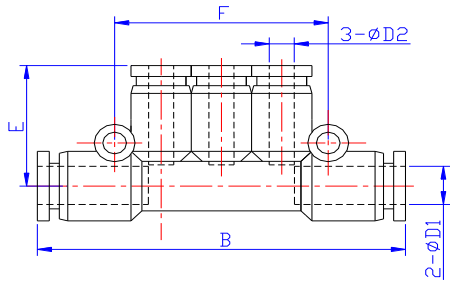

Manifold Union, MU

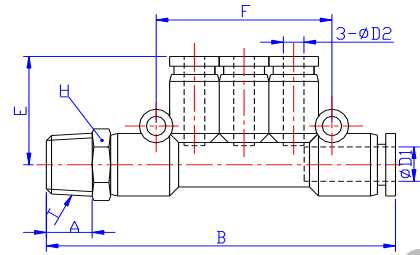

Male Manifold, MM

Part No.	ØD	B	E	F	Model	ØD1	ØD2	B	E	F	Part No.	ØD1	ØD2	T	A	B	E	F	H	
MU 5/32	5/32	57	19	36	MU 3/16-5/32	3/16	5/32	57.6	19	36	MM 3/16-5/32-N1/8	3/16	5/32	NPT 1/8	7.5	64.3	19	36	11.1	
MU 3/16	3/16	57.6	19.3	36	MU 1/4-5/32	1/4	5/32	57.6	19	36	MM 1/4-5/32-N1/8	1/4	5/32	NPT 1/8	7.5	64.3	19	36	12.7	
MU 1/4	1/4	61.6	20.3	42	MU 5/16-5/32	5/16	5/32	62.6	20	42	MM 5/16-5/32-N1/4	5/16	5/32	NPT 1/4	10.5	72.3	20	42	14.3	
MU 5/16	5/16	81.6	24.3	48	MU 5/16-3/16	5/16	3/16	62.6	20.3	42	MM 5/16-3/16-N1/4	5/16	3/16	NPT 1/4	10.5	72.3	20.3	42	14.3	
					MU 5/16-1/4	5/16	1/4	62.6	20.3	42	MM 5/16-1/4-N1/4	5/16	1/4	NPT 1/4	10.5	72.3	20.3	42	14.3	
					MU 3/8-1/4	3/8	1/4	80	23.8	48	MM 3/8-5/16-N3/8	3/8	5/16	NPT 3/8	11	91.5	24.3	48	17.4	
					MU 3/8-5/16	3/8	5/16	80	24.3	48										
					MU-6-04	6.0	4.0	61.3		40.4		MM06-04-R1/8	6.0	4.0	R1/8		68.5		40.4	12
					MU-8-04	8.0	4.0	61.7		40.9		MM08-6-R1/4	8.0	6.0	R1/4		69.9		40.9	14
					MU-8-06	8.0	6.0	62.7		40.9		MM10-8-R3/8	10.0	8.0	R3/8		91.6		47.9	17
					MU-10-06	10.0	6.0	82.9		47.1										
					MU-10-08	10.0	8.0	83.0		47.9										

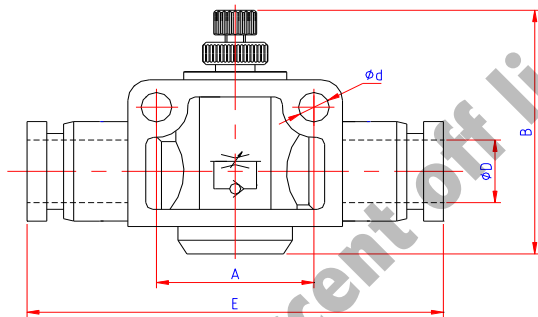

Air Flow Control Valve,

Part No.	ØD	Ød	A	B	E
FV 5/32	5/32	3.2	14	28.8	39.5
FV 3/16	3/16	3.2	14	28.8	40.1
FV 1/4	1/4	4.3	20	42.6	47.6
FV 5/16	5/16	4.3	22	44.3	52.6
FV 3/8	3/8	4.3	26	53.4	60.5
FV 1/2	1/2	4.3	32	55.6	74.2
FV-4	4	3.0			39.9
FV-6	6	4.0			49.6
FV-8	8	4.0			55.2
FV-10	10	4.0			64.9
FV-12	12	4.0			75.7

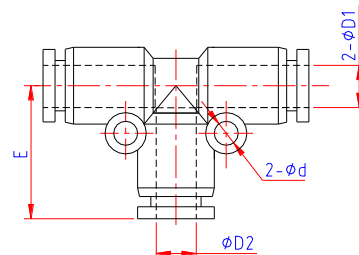

Tee Union Reducer, TU

TU				
Model	ØD1	ØD2	Ød	E
TU 1/4-5/32	1/4	5/32	3.2	19.0
TU 5/16-1/4	5/16	1/4	3.2	22.3
TU 3/8-5/16	3/8	5/16	3.2	27.8
TU 1/2-3/8	1/2	3/8	4.2	29.3

Units in mm

# Composite Push-In Air Fittings Dimensions

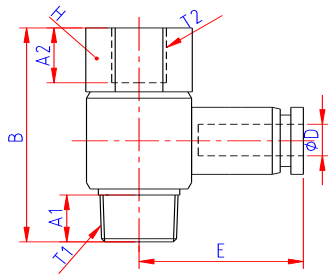

Stack Elbow, SE

SE								
ØD	T1	T2	Model	A1	A2	H	B	E
5/32	10-32UNF	10-32UNF	SE 5/32 10-32	3.8	5.5	11.1	19.5	20
	NPT1/8	NPT1/8	SE 5/32 N1/8	7.5	7.5	14.3	30	22.3
3/16	10-32UNF	10-32UNF	SE 3/16 10-32	3.8	5.5	11.1	19.5	20.3
	NPT1/8	NPT1/8	SE 3/16 N1/8	7.5	7.5	14.3	30	22.6
1/4	NPT1/4	NPT1/4	SE 3/16 N1/4	10.5	10.5	17.4	35.8	24.3
	NPT1/8	NPT1/8	SE 1/4 N1/8	7.5	7.5	14.3	30	23.1
5/16	NPT1/4	NPT1/4	SE 1/4 N1/4	10.5	10.5	17.4	35.8	25.1
	NPT1/8	NPT1/8	SE 5/16 N1/8	7.5	7.5	14.3	30	25.6
3/8	NPT1/4	NPT1/4	SE 5/16 N1/4	10.5	10.5	17.4	35.8	28.6
	NPT3/8	NPT3/8	SE 5/16 N3/8	11	11	22.2	40.9	29.6
1/2	NPT1/4	NPT1/4	SE 3/8 N1/4	10.5	10.5	17.4	35.8	31
	NPT3/8	NPT3/8	SE 3/8 N3/8	11	11	22.2	40.9	31.6
1/2	NPT3/8	NPT3/8	SE 1/2 N3/8	11	11	22.2	40.9	35.6
	NPT1/2	NPT1/2	SE 1/2 N1/2	14	14	25.4	49	36.6

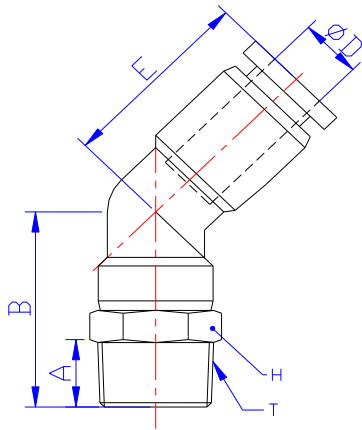

Male Angle, MA

MA						
ØD	NPT	Model	A	B	E	H
5/32	10-32UNF	MA 5/32 10-32	3.8	20.7	16.2	11.1
	NPT1/8	MA 5/32 N1/8	7.5	22.7		
	NPT1/4	MA 5/32 N1/4	10.5	26.7		
3/16	10-32UNF	MA 3/16 10-32	3.8	20.7	16.5	11.1
	NPT1/8	MA 3/16 N1/8	7.5	23.2		
	NPT3/8	MA 3/16 N3/8	11	27.7		
1/4	10-32UNF	MA 1/4 10-32	3.8	23.1	17.7	12.7
	NPT1/8	MA 1/4 N1/8	7.5	24.4		
	NPT1/4	MA 1/4 N1/4	10.5	27.9		
5/16	NPT3/8	MA 1/4 N3/8	11	28.9	20.9	14.3
	NPT1/8	MA 5/16 N1/8	7.5	27.6		
	NPT3/8	MA 5/16 N3/8	11	31.6		
3/8	NPT1/8	MA 3/8 N1/8	7.5	30.2	22.2	17.4
	NPT1/4	MA 3/8 N1/4	10.5	33.2		
	NPT3/8	MA 3/8 N3/8	11	33.7		
1/2	NPT1/2	MA 3/8 N1/2	14	37.2	26.3	22.2
	NPT1/4	MA 1/2 N1/4	10.5	36.2		
	NPT3/8	MA 1/2 N3/8	11	36.7		
	NPT1/2	MA 1/2 N1/2	14	39.7		22.2

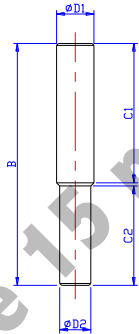

Stem Reducer, SR

SR					
Model	ØD1	ØD2	C1	C2	B
SR 3/16-5/32	3/16	5/32	18	17	36
SR 1/4-5/32	1/4	5/32	18	17	36
SR 1/4-3/16	1/4	3/16	18	17	36
SR 5/16-1/4	3/16	1/4	20	18	39
SR 3/8-5/16	3/8	5/16	25	20	46
SR 1/2-3/8	1/2	3/8	27	26	54

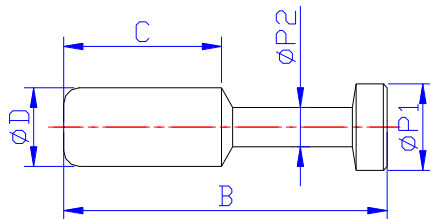

Plug, PG

PG					
Model	ØD	B	ØP1	ØP2	C
PG 5/32	5/32	28	5	3	15
PG 3/16	3/16	28	5	3	15
PG 1/4	1/4	33	7	3	17
PG 5/16	5/16	37	9	4	18
PG 3/8	3/8	42	11	5	20.5
PG 1/2	1/2	44	13	6	23

Units in mm

**Elbow Reducer, ER**

ER				
Model	ØD1	ØD2	B	E
ER 1/8-5/32	5/32	1/8	33	17.5
ER 5/32-1/4	1/4	5/32	35	17.5
ER 1/4-3/8	3/8	1/4	42.5	22.8
ER 1/4-5/16	5/16	1/4	39.2	19
ER 5/16-3/8	3/8	5/16	42.5	22.8
ER 3/8-1/2	1/2	3/8	52.8	26.3

**Tube Reducer, TR**

TR (Tube Reducer)				
Model	ØD1	ØD2	B	C
TR 5/32-1/4	1/4	5/32	39.5	16
TR 5/32-5/16	5/16	5/32	41.5	18.6
TR 1/4-5/16	5/16	1/4	41.8	18.6
TR 1/4-3/8	3/8	1/4	46.5	20
TR 5/16-3/8	3/8	5/16	46.5	20
TR 1/4-1/2	1/2	1/4	51.8	23.5
TR 5/16-1/2	1/2	5/16	52.3	23.5
TR 3/8-1/2	1/2	3/8	51.5	23.5

**Plug-In Elbow, PE**

PE			
Model	ØD	B	E
PE 5/32	5/32	33	17.5
PE 3/16	3/16	33	17.8
PE 1/4	1/4	36.2	19
PE 5/16	5/16	42.5	22.8
PE 3/8	3/8	50.8	26.3
PE 1/2	1/2	54.5	29.6

**Stem Coupling, SC**

SC		
Model	ØD	B
SC 5/32	5/32	35
SC 3/16	3/16	35
SC 1/4	1/4	37
SC 5/16	5/16	41
SC 3/8	3/8	51
SC 1/2	1/2	54

## Stainless Steel & Nickel Plated Brass Push-In Fittings Dimensions

**Bulkhead Union, BU**

Part No.	Part No.	ΦD	B	M	H
BUB 1/8	BUS 1/8	1/8	30.7	M10X1	S12
BUB 5/32	BUS 5/32	5/32	30.7	M10X1	S12
BUB 1/4	BUS 1/4	1/4	35.5	M12X1	S17
BUB 5/16	BUS 5/16	5/16	37	M17X1	S19
BUB 3/8	BUS 3/8	3/8	39	M17X1	S19
BUB 1/2	BUS 1/2	1/2	44	M21X1	S23

BUB 4	BUS 4	4	30.7	M10X1	S12
BUB 6	BUS 6	6	35.5	M12X1	S17
BUB 8	BUS 8	8	37	M17X1	S19
BUB 10	BUS 10	10			
BUB 12	BUS 12	12			

**Female Connector, FC**

Part No.	Part No.	ΦD	T, Thread	A	B	H
FCB 1/8 10-32	FCS 1/8 10-32	1/8	10-32	5.4	21	S12
FCB 1/8 N1/8	FCS 1/8 N1/8	1/8	1/8 NPT	9	22	S14
FCB 5/32 10-32	FCS 5/32 10-32	5/32	10-32	5.4	21	S12
FCB 5/32 N1/8	FCS 5/32 N1/8	5/32	1/8 NPT	9	22	S14
FCB 1/4 N1/8	FCS 1/4 N1/8	1/4	1/8 NPT	9	25.7	S14
FCB 1/4 N1/4	FCS 1/4 N1/4	1/4	1/4 NPT	12	28.7	S17
FCB 1/4 N3/8	FCS 1/4 N3/8	1/4	3/8 NPT	12.5	29.2	S19
FCB 5/16 N1/4	FCS 5/16 N1/4	5/16	1/4 NPT	12	31.5	S17
FCB 3/8 N1/4	FCS 3/8 N1/4	3/8	1/4 NPT	12	31	S17
FCB 3/8 N3/8	FCS 3/8 N3/8	3/8	3/8 NPT	12.5	33	S19
FCB 3/8 N1/2	FCS 3/8 N1/2	3/8	1/2 NPT	14.7	35.5	S24
FCB 1/2 N1/4	FCS 1/2 N1/4	1/2	1/4 NPT	12	33.2	S19
FCB 1/2 N3/8	FCS 1/2 N3/8	1/2	3/8 NPT	12.5	33.7	S19
FCB 1/2 N1/2	FCS 1/2 N1/2	1/2	1/2 NPT	15.8	37	S24

FCB 4 M5	FCS 4 M5	4	M5	5.4	21	S12
FCB 4 N1/8	FCS 4 N1/8	4	1/8 NPT	9	22	S14
FCB 8 N1/4	FCS 8 N1/4	8	1/4 NPT	12	31.5	S17
FCB 8 N3/8	FCS 8 N3/8	8	3/8 NPT	12.5	32.5	S19

Units in mm



# Stainless Steel & Nickel-Plated Brass Push-In Fittings Dimensions

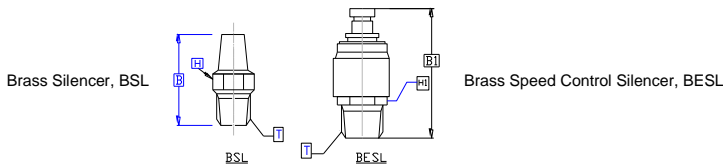
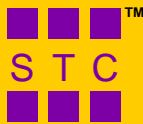

Part No.	Part No.	Port NPT	A	B	H	B1	H1
BSL-N1/8	BESL-N1/8	1/8	0.39	0.99	0.47	1.37	0.47
BSL-N1/4	BESL-N1/4	1/4	0.47	1.28	0.59	1.56	0.55
BSL-N3/8	BESL-N3/8	3/8	0.53	1.60	0.75	1.77	0.66
BSL-N1/2	BESL-N1/2	1/2	0.59	1.85	0.86	2.31	0.94

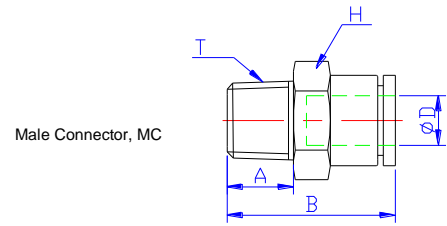

Part No.	Part No.	ΦD	Pipe Size	A	B	H
MCB 1/8 10-32	MCS 1/8 10-32	1/8	10-32	5	20	S11
MCB 1/8 N1/8	MCS 1/8 N1/8	1/8	1/8 NPT	8	17	S11
MCB 1/8 N1/4	MCS 1/8 N1/4	1/8	1/4 NPT	11	21	S14
MCB 5/32 10-32	MCS 5/32 10-32	5/32	10-32	5	20	S10
MCB 5/32 N1/8	MCS 5/32 N1/8	5/32	1/8 NPT	8	17	S11
MCB 1/4 N1/8	MCS 1/4 N1/8	1/4	1/8 NPT	8	21	S12
MCB 1/4 N1/4	MCS 1/4 N1/4	1/4	1/4 NPT	11	21	S14
MCB 1/4 N3/8	MCS 1/4 N3/8	1/4	3/8 NPT	12.5	22.5	S17
MCB 1/4 10-32	MCS 1/4 10-32	1/4	10-32	5	23	S12
MCB 5/16 N1/4	MCS 5/16 N1/4	5/16	1/4 NPT	11	25.5	S14
MCB 5/16 N3/8	MCS 5/16 N3/8	5/16	3/8 NPT	12.5	24	S17
MCB 3/8 N1/8	MCS 3/8 N1/8	3/8	1/8 NPT	9	29	S17
MCB 3/8 N1/4	MCS 3/8 N1/4	3/8	1/4 NPT	11	27	S17
MCB 3/8 N3/8	MCS 3/8 N3/8	3/8	3/8 NPT	12.5	26	S17
MCB 3/8 N1/2	MCS 3/8 N1/2	3/8	1/2 NPT	15	28	S22
MCB 1/2 N1/4	MCS 1/2 N1/4	1/2	1/4 NPT	11	33	S19
MCB 1/2 N3/8	MCS 1/2 N3/8	1/2	3/8 NPT	12.5	29.8	S19
MCB 1/2 N1/2	MCS 1/2 N1/2	1/2	1/2 NPT	15	30.4	S22
MCB 4 M5	MCS 4 M5	4mm	M5	5	20	S10
MCB 4 N1/8	MCS 4 N1/8	4mm	1/8 NPT	8	17	S10
MCS 8 N1/4	MCS 8 N1/4	8mm	1/4 NPT	11	25.5	S14
MCS 8 N3/8	MCS 8 N3/8	8mm	3/8 NPT	12.5	24	S17

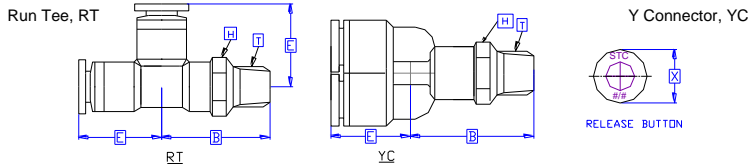

Part No.	Part No.	Part No.	Part No.	Tube OD	T, Thread	A	B	H	E	X
RTB 5/32 10-32	RTS 5/32 10-32	YCB 5/32 10-32	YCS 5/32 10-32	5/32	10-32	0.24	0.99	0.31	0.81	0.39
RTB 5/32 N1/8	RTS 5/32 N1/8	YCB 5/32 N1/8	YCS 5/32 N1/8	5/32	1/8 NPT	0.39	0.86	0.47	0.81	0.39
RTB 1/4 N1/8	RTS 1/4 N1/8	YCB 1/4 N1/8	YCS 1/4 N1/8	1/4	1/8 NPT	0.37	0.85	0.47	0.97	0.47
RTB 1/4 N1/4	RTS 1/4 N1/4	YCB 1/4 N1/4	YCS 1/4 N1/4	1/4	1/4 NPT	0.51	1.02	0.55	0.97	0.47
RTB 1/4 N3/8	RTS 1/4 N3/8	YCB 1/4 N3/8	YCS 1/4 N3/8	1/4	3/8 NPT	0.53	1.14	0.67	0.97	0.47
RTB 5/16 N1/4	RTS 5/16 N1/4	YCB 5/16 N1/4	YCS 5/16 N1/4	5/16	1/4 NPT	0.50	1.09	0.55	1.18	0.67
RTB 5/16 N3/8	RTS 5/16 N3/8	YCB 5/16 N3/8	YCS 5/16 N3/8	5/16	3/8 NPT	0.53	1.09	0.67	1.18	0.67
RTB 3/8 N1/4	RTS 3/8 N1/4	YCB 3/8 N1/4	YCS 3/8 N1/4	3/8	1/4 NPT	0.50	1.09	0.55	1.18	0.67
RTB 3/8 N3/8	RTS 3/8 N3/8	YCB 3/8 N3/8	YCS 3/8 N3/8	3/8	3/8 NPT	0.53	1.09	0.67	1.18	0.67
RTB 3/8 N1/2	RTS 3/8 N1/2	YCB 3/8 N1/2	YCS 3/8 N1/2	3/8	1/2 NPT	0.60	1.18	0.87	1.18	0.67
RTB 1/2 N3/8	RTS 1/2 N3/8	YCB 1/2 N3/8	YCS 1/2 N3/8	1/2	3/8 NPT	0.53	1.17	0.67	1.28	0.75
RTB 1/2 N1/2	RTS 1/2 N1/2	YCB 1/2 N1/2	YCS 1/2 N1/2	1/2	1/2 NPT	0.60	1.26	0.86	1.28	0.75

RTB 4 M5	RTS 4 M5	YCB 4 M5	YCS 4 M5	4mm	M5	0.24	0.99	0.31	0.81	0.39
RTB 4 N1/8	RTS 4 N1/8	YCB 4 N1/8	YCS 4 N1/8	4mm	1/8 NPT	0.39	0.86	0.47	0.81	0.39
RTB 8 N1/4	RTS 8 N1/4	YCB 8 N1/4	YCS 8 N1/4	8mm	1/4 NPT	0.50	1.09	0.55	1.18	0.67
RTB 8 N3/8	RTS 8 N3/8	YCB 8 N3/8	YCS 8 N3/8	8mm	3/8 NPT	0.53	1.09	0.67	1.18	0.67

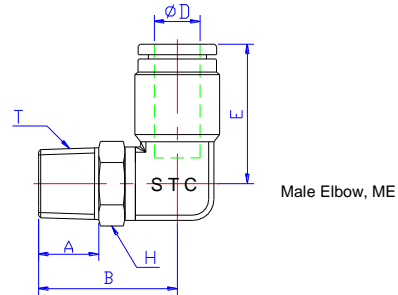
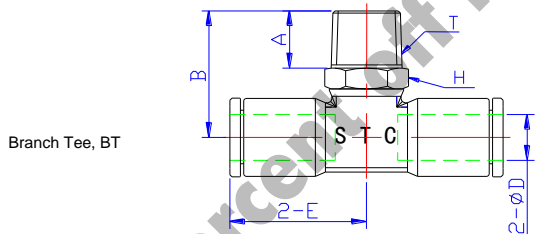

ΦD	T, Thread	H	Part No.	Part No.	A	B	E	Part No.	Part No.	A	B	E
1/8	10-32	S11	BTB 1/8 10-32	BTS 1/8 10-32	5.4	19.4	16.2	MEB 1/8 10-32	MES 1/8 10-32	5.4	19.4	16.2
1/8	1/8 NPT	S11	BTB 1/8 N1/8	BTS 1/8 N1/8	8.2	22.4	16.2	MEB 1/8 N1/8	MES 1/8 N1/8	8.1	18.8	16.2
5/32"	10-32	S11	BTB 5/32 10-32	BTS 5/32 10-32	5.4	19.4	16.2	MEB 5/32 10-32	MES 5/32 10-32	5.4	19.5	16.2
5/32"	1/8 NPT	S11	BTB 5/32 N1/8	BTS 5/32 N1/8	8.2	19.4	16.2	MEB 5/32 N1/8	MES 5/32 N1/8	8.1	19.1	16.2
1/4"	1/8 NPT	S11	BTB 1/4 N1/8	BTS 1/4 N1/8	8.2	21	20	MEB 1/4 N1/8	MES 1/4 N1/8	8.1	21	17.5
1/4"	1/4 NPT	S14	BTB 1/4 N1/4	BTS 1/4 N1/4	11.5	24.7	20	MEB 1/4 N1/4	MES 1/4 N1/4	11.5	25.3	17.5
1/4"	3/8 NPT	S17	BTB 1/4 N3/8	BTS 1/4 N3/8	12	25.2	20	MEB 1/4 N3/8	MES 1/4 N3/8	12	25.8	17.5
5/16"	1/4 NPT	S14	BTB 5/16 N1/4	BTS 5/16 N1/4	11.5	25.9	21.5	MEB 5/16 N1/4	MES 5/16 N1/4	11.5	26.6	22.5
5/16"	3/8 NPT	S17	BTB 5/16 N3/8	BTS 5/16 N3/8	12	26.4	21.5					
3/8"	1/4 NPT	S14	BTB 3/8 N1/4	BTS 3/8 N1/4	11.5	27.5	25.5	MEB 3/8 N1/4	MES 3/8 N1/4	11.5	26.5	25.8
3/8"	3/8 NPT	S17	BTB 3/8 N3/8	BTS 3/8 N3/8	12	28	25.5	MEB 3/8 N3/8	MES 3/8 N3/8	12	27	25.8
3/8"	1/2 NPT	S22	BTB 3/8 N1/2	BTS 3/8 N1/2	15	31	25.5	MEB 3/8 N1/2	MES 3/8 N1/2	15	30	25.8
1/2"	1/4 NPT	S14	BTB 1/2 N1/4	BTS 1/2 N1/4	15	28.8	27.5	MEB 1/2 N1/4	MES 1/2 N1/4	11.5	27.8	27.4
1/2"	3/8 NPT	S17	BTB 1/2 N3/8	BTS 1/2 N3/8	12	29.3	27.5	MEB 1/2 N3/8	MES 1/2 N3/8	12	28.3	27.4
1/2"	1/2 NPT	S22	BTB 1/2 N1/2	BTS 1/2 N1/2	15	32.3	27.5	MEB 1/2 N1/2	MES 1/2 N1/2	15	31.3	27.4

4	M5	S11	BTB 4 M5	BTS 4 M5	5.4	19.4	16.2	MEB 4 M5	MES 4 M5	5.4	19.5	16.2
4	1/8 NPT	S11	BTB 4 N1/8	BTS 4 N1/8	8.2			MEB 4 N1/8	MES 4 N1/8	8.2	11.8	16.2
8	1/4 NPT	S14	BTB 8 N1/4	BTS 8 N1/4	11.5	25.9	21.5	MEB 8 N1/4	MES 8 N1/4	11.5	26.6	22.5
8	3/8 NPT	S17	BTB 8 N3/8	BTS 8 N3/8	12	26.4	21.5	MEB 8 N3/8	MES 8 N3/8	12	27.1	22.5

Units in mm

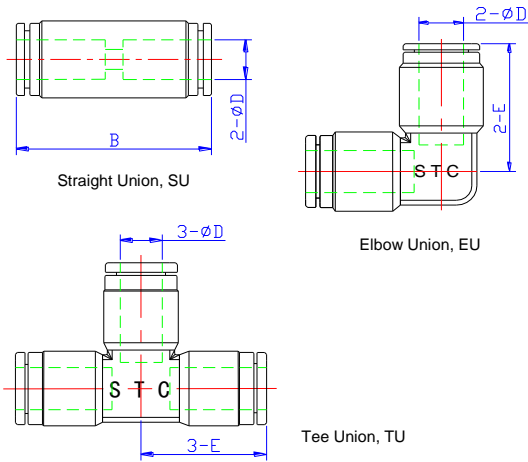

∅D	Part No.	Part No.	E	Part No.	Part No.	B	Part No.	Part No.	E
1/8	EUB 1/8	EUS 1/8	16.2	SUB 1/8	SUS 1/8	35.5	TUB 1/8	TUS 1/8	16.25
5/32	EUB 5/32	EUS 5/32	16.2	SUB 5/32	SUS 5/32	35.5	TUB 5/32	TUS 5/32	16.25
1/4	EUB 1/4	EUS 1/4	17.5	SUB 1/4	SUS 1/4	35.5	TUB 1/4	TUS 1/4	20
5/16	EUB 5/16	EUS 5/16	22.5	SUB 5/16	SUS 5/16	37	TUB 5/16	TUS 5/16	22.6
3/8	EUB 3/8	EUS 3/8	25.8	SUB 3/8	SUS 3/8	44	TUB 3/8	TUS 3/8	25.5
1/2	EUB 1/2	EUS 1/2	27.4	SUB 1/2	SUS 1/2	42.4	TUB 1/2	TUS 1/2	27.5

4mm	EUB 4	EUS 4	16.2	SUB 4	SUS 4		TUB 4	TUS 4	16.25
6mm	EUB 6	EUS 6		SUB 6	SUS 6	35.5	TUB 6	TUS 6	
8mm	EUB 8	EUS 8	22.5	SUB 8	SUS 8	37	TUB 8	TUS 8	22.6
10mm	EUB 10	EUS 10		SUB 10	SUS 10		TUB 10	TUS 10	
12mm	EUB 12	EUS 12		SUB 12	SUS 12		TUB 12	TUS 12	

### STC FLOW CONTROL VALVES AIR FLOW CHARACTERISTICS

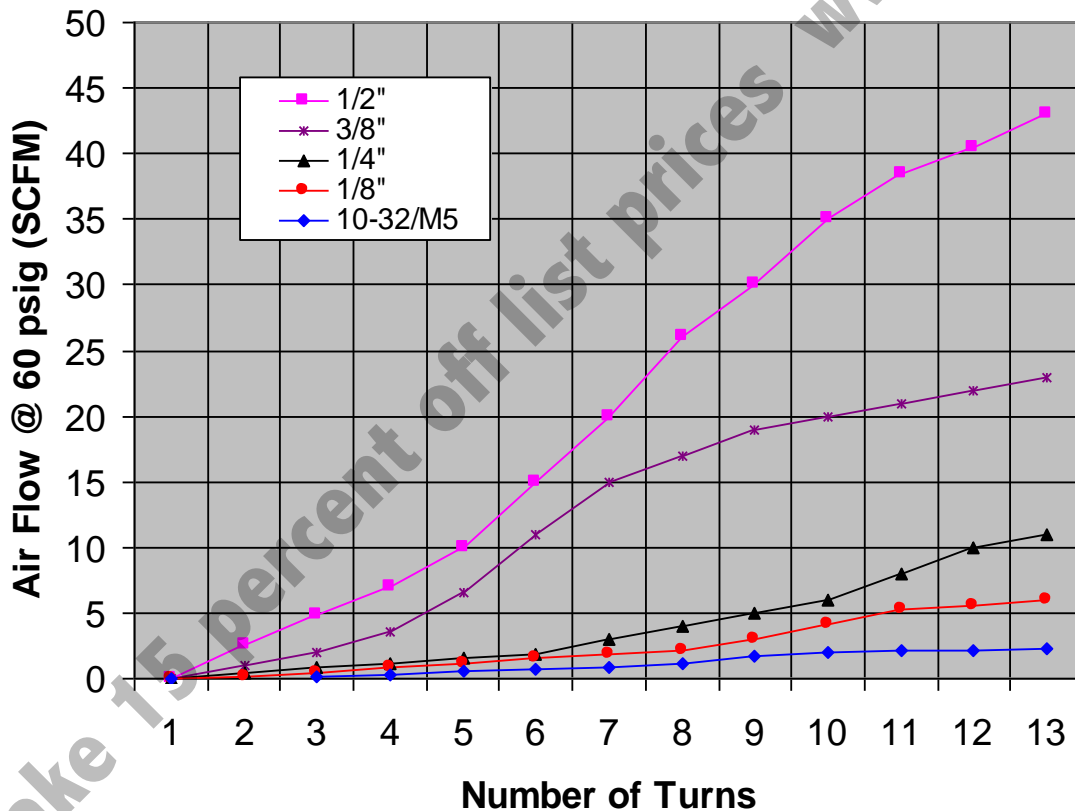

#### Special Features:

- Complete rotation of the valve body around the bolt allows for optimum positioning of tubing
- Compact in size provide space saving installations
- Special adjustment needle design allows large adjustment ranges with high precision
- Adjustment needles and banjo bodies are retained, preventing accidental loss of needle or lock nut



# Air Filter-Regulator-Lubricator



Precision Engineered

Fine Quality



Advanced Design

Excellent Prices



## Contents

Filter Regulator Lubricator Numbering System.....	B2
Filter Regulator Lubricator List Price.....	B3-5
FRL Accessories List Price.....	B6
Filter Regulator Lubricator Flow Charts.....	B7-11
Filter Regulator Lubricator Dimensions.....	B12-15
Filter Regulator Lubricator Specifications.....	B16

## Filter Regulator Lubricator Numbering System

Ordering Part No. =  
(eg. AC 1000-00-D)

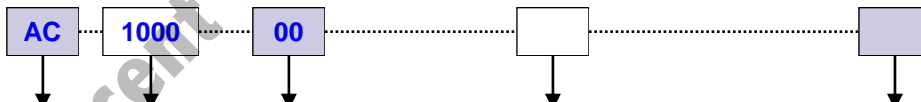

Model	Body Size	Port Size	Standard Features	Options
AC = Filter-Regulator-Lubricator AF = Filter AL = Lubricator AR = Regulator AW = Stacking Filter-Regulator VHS = Relieving Shut-off/Lockout Valve	1000 2000 3000 4000 5000	00 = 10-32 (M5) 01 = 1/8 NPT 02 = 1/4 NPT 03 = 3/8 NPT 04 = 1/2 NPT 06 = 3/4 NPT 10 = 1 NPT	Blank = Following Features:  Polycarbonate Bowl (3000-5000 Series with Steel Bowl Shield)  125 PSI Regulating Range  Semi-auto Differential Drain  25 Micron Sintered Brass Filter	D = Automatic Drain  DC = Drain Cock (with manual shut off valve)  M = Metal Bowl (with sight glass)  P30 = 30PSI Regulating Range  P60 = 60 PSI Regulating Range  F5 = 5 Micron Filter  N = Without B = Bracket G = Pressure Gauge
AC = Stacking Filter-Regulator-Lubricator	1010 2010 3010 4010 5010			

# Air Filter-Regulator-Lubricator List Price

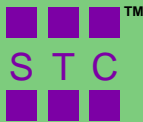



	Part No.	Description (*includes Bracket & Gauge)	List Price
 <p>Includes Bracket &amp; Gauge</p>	AC 1000-M5	M5/10-32 Filter- Regulator- Lubricator* (3 SCFM)	\$46.83*
	AC 2000-01	1/8" NPT Filter- Regulator- Lubricator* (18 SCFM)	\$49.16*
	AC 2000-01D	1/8" NPT Filter- Regulator- Lubricator* with Auto Drain (18 SCFM)	\$65.98*
	AC 2000-01M	1/8" NPT Filter- Regulator- Lubricator* Metal Bowl (18 SCFM)	\$57.96*
	AC 2000-01DM	1/8" NPT Filter- Regulator- Lubricator* with Auto Drain & Metal Bowl (18 SCFM)	\$68.00*
	AC 2000-02	1/4" NPT Filter- Regulator- Lubricator* (18 SCFM)	\$49.16*
	AC 2000-02D	1/4" NPT Filter- Regulator- Lubricator* with Auto Drain (18 SCFM)	\$65.98*
	AC 2000-02M	1/4" NPT Filter- Regulator- Lubricator* Metal Bowl (18 SCFM)	\$57.96*
	AC 2000-02DM	1/4" NPT Filter- Regulator- Lubricator* with Auto Drain & Metal Bowl (18 SCFM)	\$68.00*
 <p>Includes Bracket &amp; Gauge</p>	AC 3000-02	1/4" NPT Filter- Regulator- Lubricator* (70 SCFM)	\$75.60*
	AC 3000-02D	1/4" NPT Filter- Regulator- Lubricator* with Auto Drain (70 SCFM)	\$97.59*
	AC 3000-02M	1/4" NPT Filter- Regulator- Lubricator* with Metal Bowl (70 SCFM)	\$88.79*
	AC 3000-02DM	1/4" NPT Filter- Regulator- Lubricator* with Auto Drain & Metal Bowl (70 SCFM)	\$110.79*
	AC 3000-03	3/8" NPT Filter- Regulator- Lubricator* (70 SCFM)	\$75.60*
	AC 3000-03D	3/8" NPT Filter- Regulator- Lubricator* with Auto Drain (70 SCFM)	\$97.59*
	AC 3000-03M	3/8" NPT Filter- Regulator- Lubricator* with Metal Bowl (70 SCFM)	\$88.79*
	AC 3000-03DM	3/8" NPT Filter- Regulator- Lubricator* with Auto Drain & Metal Bowl (70 SCFM)	\$110.79*
	AC 4000-03	3/8" NPT Filter- Regulator- Lubricator* (140 SCFM)	\$101.97*
	AC 4000-03D	3/8" NPT Filter- Regulator- Lubricator* with Auto Drain (140 SCFM)	\$129.38*
	AC 4000-03M	3/8" NPT Filter- Regulator- Lubricator* with Metal Bowl (140 SCFM)	\$128.37*
	AC 4000-03DM	3/8" NPT Filter- Regulator- Lubricator* with Auto Drain & Metal Bowl (140 SCFM)	\$143.77*
	AC 4000-04	1/2" NPT Filter- Regulator- Lubricator* (140 SCFM)	\$101.97*
	AC 4000-04D	1/2" NPT Filter- Regulator- Lubricator* with Auto Drain (140 SCFM)	\$129.38*
	AC 4000-04M	1/2" NPT Filter- Regulator- Lubricator* with Metal Bowl (140 SCFM)	\$128.37*
	AC 4000-04DM	1/2" NPT Filter- Regulator- Lubricator* with Auto Drain & Metal Bowl (140 SCFM)	\$143.77*
	AC 4000-06	3/4" NPT Filter- Regulator- Lubricator* (160 SCFM)	\$111.53*
	AC 4000-06D	3/4" NPT Filter- Regulator- Lubricator* with Auto Drain (160 SCFM)	\$138.94*
	AC 4000-06M	3/4" NPT Filter- Regulator- Lubricator* with Metal Bowl (160 SCFM)	\$137.93*
	AC 4000-06DM	3/4" NPT Filter- Regulator- Lubricator* with Auto Drain & Metal Bowl (160 SCFM)	\$153.33*
	AC 5000-10	1" NPT Filter- Regulator- Lubricator* (180 SCFM)	\$140.58*
AC 5000-10D	1" NPT Filter- Regulator- Lubricator* with Auto Drain (180 SCFM)	\$176.87*	
AC 5000-10M	1" NPT Filter- Regulator- Lubricator* with Metal Bowl (180 SCFM)	\$166.98*	
AC 5000-10DM	1" NPT Filter- Regulator- Lubricator* with Auto Drain & Metal Bowl (180 SCFM)	\$182.38*	
 <p>Includes Bracket &amp; Gauge</p>	AC 1010-M5	M5/10-32 Stacking Filter- Regulator- Lubricator* (3 SCFM)	\$41.88*
	AC 2010-01	1/8" NPT Stacking Filter- Regulator- Lubricator* (18 SCFM)	\$44.55*
	AC 2010-01D	1/8" NPT Stacking Filter- Regulator- Lubricator* with Auto Drain (18 SCFM)	\$61.41*
	AC 2010-01M	1/8" NPT Stacking Filter- Regulator- Lubricator* with Metal Bowl (18 SCFM)	\$53.35*
	AC 2010-01DM	1/8" NPT Stacking Filter- Regulator- Lubricator* with Auto Drain & Metal Bowl (18 SCFM)	\$68.00*
	AC 2010-02	1/4" NPT Stacking Filter- Regulator- Lubricator* (18 SCFM)	\$44.55*
	AC 2010-02D	1/4" NPT Stacking Filter- Regulator- Lubricator* with Auto Drain (18 SCFM)	\$61.41*
	AC 2010-02M	1/4" NPT Stacking Filter- Regulator- Lubricator* with Metal Bowl (18 SCFM)	\$53.35*
	AC 2010-02DM	1/4" NPT Stacking Filter- Regulator- Lubricator* with Auto Drain & Metal Bowl (18 SCFM)	\$68.00*
 <p>Includes Bracket &amp; Gauge</p>	AC 3010-02	1/4" NPT Stacking Filter- Regulator- Lubricator* (60 SCFM)	\$62.37*
	AC 3010-02D	1/4" NPT Stacking Filter- Regulator- Lubricator* with Auto Drain (60 SCFM)	\$84.37*
	AC 3010-02M	1/4" NPT Stacking Filter- Regulator- Lubricator* with Metal Bowl (60 SCFM)	\$75.57*
	AC 3010-02DM	1/4" NPT Stacking Filter- Regulator- Lubricator* with Auto Drain & Metal Bowl (60 SCFM)	\$88.77*
	AC 3010-03	3/8" NPT Stacking Filter- Regulator- Lubricator* (60 SCFM)	\$62.37*
	AC 3010-03D	3/8" NPT Stacking Filter- Regulator- Lubricator* with Auto Drain (60 SCFM)	\$84.37*
	AC 3010-03M	3/8" NPT Stacking Filter- Regulator- Lubricator* with Metal Bowl (60 SCFM)	\$75.57*
	AC 3010-03DM	3/8" NPT Stacking Filter- Regulator- Lubricator* with Auto Drain & Metal Bowl (60 SCFM)	\$88.77*
	AC 4010-03	3/8" NPT Stacking Filter- Regulator- Lubricator* (105 SCFM)	\$90.09*
	AC 4010-03D	3/8" NPT Stacking Filter- Regulator- Lubricator* with Auto Drain (105 SCFM)	\$117.50*
	AC 4010-03M	3/8" NPT Stacking Filter- Regulator- Lubricator* with Metal Bowl (105 SCFM)	\$116.49*
	AC 4010-03DM	3/8" NPT Stacking Filter- Regulator- Lubricator* with Auto Drain & Metal Bowl (105 SCFM)	\$131.89*
	AC 4010-04	1/2" NPT Stacking Filter- Regulator- Lubricator* (105 SCFM)	\$90.09*
	AC 4010-04D	1/2" NPT Stacking Filter- Regulator- Lubricator* with Auto Drain (105 SCFM)	\$117.50*
	AC 4010-04M	1/2" NPT Stacking Filter- Regulator- Lubricator* with Metal Bowl (105 SCFM)	\$116.49*
	AC 4010-04DM	1/2" NPT Stacking Filter- Regulator- Lubricator* with Auto Drain & Metal Bowl (105 SCFM)	\$131.89*
	AC 4010-06	3/4" NPT Stacking Filter- Regulator- Lubricator* (105 SCFM)	\$102.96*
	AC 4010-06D	3/4" NPT Stacking Filter- Regulator- Lubricator* with Auto Drain (105 SCFM)	\$130.37*
	AC 4010-06M	3/4" NPT Stacking Filter- Regulator- Lubricator* with Metal Bowl (105 SCFM)	\$129.36*
	AC 4010-06DM	3/4" NPT Stacking Filter- Regulator- Lubricator* with Auto Drain & Metal Bowl (105 SCFM)	\$144.76*
	AC 5010-10	1" NPT Stacking Filter- Regulator- Lubricator* (140 SCFM)	\$128.70*
AC 5010-10D	1" NPT Stacking Filter- Regulator- Lubricator* with Auto Drain (140 SCFM)	\$156.11*	
AC 5010-10M	1" NPT Stacking Filter- Regulator- Lubricator* with Metal Bowl (140 SCFM)	\$155.10*	
AC 5010-10DM	1" NPT Stacking Filter- Regulator- Lubricator* with Auto Drain & Metal Bowl (140 SCFM)	\$170.50*	





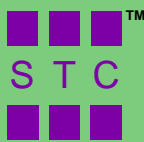



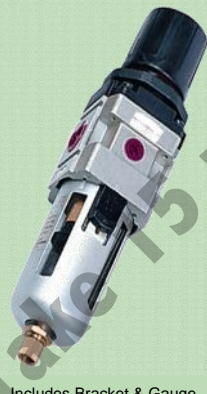



	Part No.	Description (* Includes Bracket & Gauge)	List Price
 <p>Includes Bracket &amp; Gauge</p>	AR1000-M5	M5/10-32 Regulator* (4 SCFM)	\$19.76*
	AR2000-01	1/8" NPT Regulator* (19 SCFM)	\$20.45*
	AR2000-02	1/4" NPT Regulator* (19 SCFM)	\$20.45*
	AR2500-02	1/4" NPT Regulator* (50 SCFM)	\$29.21*
	AR3000-02	1/4" NPT Regulator* (88 SCFM)	\$31.68*
	AR3000-03	3/8" NPT Regulator* (88 SCFM)	\$31.68*
	AR4000-03	3/8" NPT Regulator* (210 SCFM)	\$42.23*
	AR4000-04	1/2" NPT Regulator* (210 SCFM)	\$42.23*
	AR4000-06	3/4" NPT Regulator* (210 SCFM)	\$48.84*
	AR5000-10	1" NPT Regulator* (280 SCFM)	\$52.82*
	AF1000-M5	M5 Filter (4 SCFM)	\$11.88
	AF2000-01	1/8" NPT Filter (26 SCFM)	\$12.23
	AF2000-01D	1/8" NPT Filter with Auto Drain (26 SCFM)	\$29.10
	AF2000-01M	1/8" NPT Filter with Metal Bowl (26 SCFM)	\$18.21
	AF2000-01DM	1/8" NPT Filter with Auto Drain & Metal Bowl (26 SCFM)	\$30.69
	AF2000-02	1/4" NPT Filter (26 SCFM)	\$12.23
	AF2000-02D	1/4" NPT Filter with Auto Drain (26 SCFM)	\$29.10
	AF2000-02M	1/4" NPT Filter with Metal Bowl (26 SCFM)	\$18.21
AF2000-02DM	1/4" NPT Filter Auto Drain & Metal Bowl (26 SCFM)	\$30.69	
 <p>With Metal Bowl</p>  <p>Polycarbonate Bowl with Metal Shield</p>	AF3000-02	1/4" NPT Filter (70 SCFM)	\$18.47
	AF3000-02D	1/4" NPT Filter with Auto Drain (70 SCFM)	\$40.48
	AF3000-02M	1/4" NPT Filter with Metal Bowl (70 SCFM)	\$25.07
	AF3000-02DM	1/4" NPT Filter Auto Drain & Metal Bowl (70 SCFM)	\$44.00
	AF3000-03	3/8" NPT Filter (70 SCFM)	\$18.47
	AF3000-03D	3/8" NPT Filter with Auto Drain (70 SCFM)	\$40.48
	AF3000-03M	3/8" NPT Filter with Metal Bowl (70 SCFM)	\$25.07
	AF3000-03DM	3/8" NPT Filter Auto Drain & Metal Bowl (70 SCFM)	\$44.00
	AF4000-03	3/8" NPT Filter (140 SCFM)	\$25.74
	AF4000-03D	3/8" NPT Filter with Auto Drain (140 SCFM)	\$47.74
	AF4000-03M	3/8" NPT Filter with Metal Bowl (140 SCFM)	\$32.34
	AF4000-03DM	3/8" NPT Filter Auto Drain & Metal Bowl (140 SCFM)	\$54.34
	AF4000-04	1/2" NPT Filter (140 SCFM)	\$25.74
	AF4000-04D	1/2" NPT Filter with Auto Drain (140 SCFM)	\$47.74
	AF4000-04M	1/2" NPT Filter with Metal Bowl (140 SCFM)	\$32.34
	AF4000-04DM	1/2" NPT Filter Auto Drain & Metal Bowl (140 SCFM)	\$54.34
	AF4000-06	3/4" NPT Filter (210 SCFM)	\$28.71
	AF4000-06D	3/4" NPT Filter with Auto Drain (210 SCFM)	\$56.12
	AF4000-06M	3/4" NPT Filter with Metal Bowl (210 SCFM)	\$35.31
	AF4000-06DM	3/4" NPT Filter Auto Drain & Metal Bowl (210 SCFM)	\$57.31
AF5000-10	1" NPT Filter (245 SCFM)	\$38.27	
AF5000-10D	1" NPT Filter with Auto Drain (245 SCFM)	\$65.73	
AF5000-10M	1" NPT Filter with Metal Bowl (245 SCFM)	\$44.87	
AF5000-10DM	1" NPT Filter with Auto Drain & Metal Bowl (245 SCFM)	\$66.87	

# Air Filter-Regulator-Lubricator List Price



	Part No.	Description (* Includes Bracket & Gauge)	List Price
	AL1000-M5	M5 Lubricator (3 SCFM)	\$11.88
	AL2000-01	1/8" NPT Lubricator (28 SCFM)	\$12.23
	AL2000-01M	1/8" NPT Lubricator with Metal Bowl (28 SCFM)	\$16.63
	AL2000-02	1/4" NPT Lubricator (28 SCFM)	\$12.23
	AL2000-02M	1/4" NPT Lubricator with Metal Bowl (28 SCFM)	\$16.63
	AL3000-02	1/4" NPT Lubricator (60 SCFM)	\$18.47
	AL3000-02M	1/4" NPT Lubricator with Metal Bowl (60 SCFM)	\$25.07
	AL3000-03	3/8" NPT Lubricator (60 SCFM)	\$18.47
	AL3000-03M	3/8" NPT Lubricator with Metal Bowl (60 SCFM)	\$25.07
	AL4000-03	3/8" NPT Lubricator (180 SCFM)	\$25.74
	AL4000-03M	3/8" NPT Lubricator with Metal Bowl (180 SCFM)	\$38.94
	AL4000-04	1/2" NPT Lubricator (180 SCFM)	\$25.74
	AL4000-04M	1/2" NPT Lubricator with Metal Bowl (180 SCFM)	\$38.94
	AL4000-06	3/4" NPT Lubricator (220 SCFM)	\$28.71
	AL4000-06M	3/4" NPT Lubricator with Metal Bowl (220 SCFM)	\$41.91
	AL5000-10	1" NPT Lubricator (245 SCFM)	\$40.59
	AL5000-10M	1" NPT Lubricator with Metal Bowl (245 SCFM)	\$53.79
 <p>Includes Bracket &amp; Gauge</p>	AW1000-M5	M5 Filter- Regulator* (3 SCFM)	\$29.30*
	AW2000-01	1/8" NPT Filter- Regulator* (19 SCFM)	\$29.36*
	AW2000-01D	1/8" NPT Filter- Regulator* with Auto Drain (19 SCFM)	\$44.76*
	AW2000-01M	1/8" NPT Filter- Regulator* with Metal Bowl (19 SCFM)	\$33.76*
	AW2000-01DM	1/8" NPT Filter- Regulator* Auto Drain & Metal Bowl (19 SCFM)	\$49.16*
	AW2000-02	1/4" NPT Filter- Regulator* (19 SCFM)	\$29.36*
	AW2000-02D	1/4" NPT Filter- Regulator* with Auto Drain (19 SCFM)	\$44.76*
	AW2000-02M	1/4" NPT Filter- Regulator* with Metal Bowl (19 SCFM)	\$33.76*
AW2000-02DM	1/4" NPT Filter- Regulator* Auto Drain & Metal Bowl (19 SCFM)	\$49.16*	
 <p>Includes Bracket &amp; Gauge</p>	AW3000-02	1/4" NPT Filter- Regulator* (70 SCFM)	\$39.6*
	AW3000-02D	1/4" NPT Filter- Regulator* with Auto Drain (70 SCFM)	\$61.60*
	AW3000-02M	1/4" NPT Filter- Regulator* with Metal Bowl (70 SCFM)	\$46.20*
	AW3000-02DM	1/4" NPT Filter- Regulator* Auto Drain & Metal Bowl (70 SCFM)	\$68.20*
	AW3000-03	3/8" NPT Filter- Regulator* (70 SCFM)	\$39.6*
	AW3000-03D	3/8" NPT Filter- Regulator* with Auto Drain (70 SCFM)	\$61.60*
	AW3000-03M	3/8" NPT Filter- Regulator* with Metal Bowl (70 SCFM)	\$46.20*
	AW3000-03DM	3/8" NPT Filter- Regulator* Auto Drain & Metal Bowl (70 SCFM)	\$68.20*
	AW4000-03	3/8" NPT Filter- Regulator* (140 SCFM)	\$59.40*
	AW4000-03D	3/8" NPT Filter- Regulator* with Auto Drain (140 SCFM)	\$86.81*
	AW4000-03M	3/8" NPT Filter- Regulator* with Metal Bowl (140 SCFM)	\$72.60*
	AW4000-03DM	3/8" NPT Filter- Regulator* Auto Drain & Metal Bowl (140 SCFM)	\$100.00*
	AW4000-04	1/2" NPT Filter- Regulator* (140 SCFM)	\$59.40*
	AW4000-04D	1/2" NPT Filter- Regulator* with Auto Drain (140 SCFM)	\$86.81*
	AW4000-04M	1/2" NPT Filter- Regulator* with Metal Bowl (140 SCFM)	\$72.60*
	AW4000-04DM	1/2" NPT Filter- Regulator* Auto Drain & Metal Bowl (140 SCFM)	\$100.00*
	AW4000-06	3/4" NPT Filter- Regulator* (160 SCFM)	\$69.30*
	AW4000-06D	3/4" NPT Filter- Regulator* with Auto Drain (160 SCFM)	\$96.71*
	AW4000-06M	3/4" NPT Filter- Regulator* with Metal Bowl (160 SCFM)	\$82.50*
	AW4000-06DM	3/4" NPT Filter- Regulator* Auto Drain & Metal Bowl (160 SCFM)	\$109.91*
AW5000-10	1" NPT Filter- Regulator* (195 SCFM)	\$82.52*	
AW5000-10D	1" NPT Filter- Regulator* with Auto Drain (195 SCFM)	\$109.93*	
AW5000-10M	1" NPT Filter- Regulator* with Metal Bowl (195 SCFM)	\$95.72*	
AW5000-10DM	1" NPT Filter- Regulator* Auto Drain & Metal Bowl (195 SCFM)	\$123.13*	

	Part No.	Description	List Price
	Y20	Spacer for AC2000	\$3.84
	Y30	Spacer for AC3000	\$6.39
	Y40	Spacer for AC4000-04	\$7.67
	Y50	Spacer for AC4000-06	\$7.67
	Y60	Spacer for AC5000	\$7.99
	Y20L	L-Type Spacer Bracket for AC2000	\$3.84
	Y30L	L-Type Spacer Bracket for AC3000	\$6.39
	Y40L	L-Type Spacer Bracket for AC4000-04	\$7.67
	Y50L	L-Type Spacer Bracket for AC4000-06	\$7.67
	Y60L	L-Type Spacer Bracket for AC5000	\$7.99
	Y20T	T-Type Spacer Bracket for AC2010	\$4.48
	Y30T	T-Type Spacer Bracket for AC3010	\$7.03
	Y40T	T-Type Spacer Bracket for AC4010-04	\$8.31
	Y50T	T-Type Spacer Bracket for AC4010-06	\$8.95
	Y60T	T-Type Spacer Bracket for AC5010	\$10.23
		Y21-N01	T-Type Spacer with 1/8 NPT Port for AC2000
Y21-N02		T-Type Spacer with 1/4 NPT Port for AC2000	\$6.39
Y31-N01		T-Type Spacer with 1/8 NPT Port for AC3000	\$9.59
Y31-N02		T-Type Spacer with 1/4 NPT Port for AC3000	\$9.59
Y41-N02		T-Type Spacer with 1/4 NPT Port for AC4000	\$11.51
Y41-N03		T-Type Spacer with 3/8 NPT Port for AC4000	\$11.51
Y61-N03		T-Type Spacer with 3/8 NPT Port for AC5000	\$15.98
	B110L	L-Bracket for AC1000	\$3.30
	B210L	L-Bracket for AC2000	\$3.85
	B310L	L-Bracket for AC3000	\$4.40
	B410L	L-Bracket for AC4000	\$4.95
	B510L	L-Bracket for AC4000-06	\$6.05
	B110T	T-Bracket for AC1010	\$3.85
	B210T	T-Bracket for AC2010	\$4.40
	B310T	T-Bracket for AC3010	\$4.95
	B410T	T-Bracket for AC4010	\$5.50
	B510T	L-Bracket for AC4010-06	\$6.60
	B120	Bracket for AR/AW1000	\$1.91
	B220	Bracket for AR/AW2000	\$1.91
	B320	Bracket for AR/AW3000	\$2.55
	B420	Bracket for AR/AW4000-5000	\$3.20
	B240	Bracket for AF/AL2000	\$1.91
	B340	Bracket for AF/AL3000	\$2.55
	B440	Bracket for AF/AL4000-04	\$3.20
	B540	Bracket for AF/AL4000-06	\$3.84
	B640	Bracket for AF/AL5000	\$5.12
	GE-1-160-00	1" Dia. 1/16" R 0-160 PSI back mount pressure gauge	\$6.16
	GE-1 1/2-30-01	1 1/2" Dia. 1/8" NPT 0-30 PSI back mount pressure gauge	\$6.16
	GE-1 1/2-60-01	1 1/2" Dia. 1/8" NPT 0-60 PSI back mount pressure gauge	\$6.16
	GE-1 1/2-160-01	1 1/2" Dia. 1/8" NPT 0-160 PSI back mount pressure gauge	\$6.16
	GP-1 1/2-160-01	1 1/2" Dia. 1/8" NPT 0-160 PSI panel mount pressure gauge	\$7.16
	GE-2-30-02	2" Dia. 1/4" NPT 0-30 PSI back mount pressure gauge	\$6.60
	GE-2-60-02	2" Dia. 1/4" NPT 0-60 PSI back mount pressure gauge	\$6.60
	GE-2-160-02	2" Dia. 1/4" NPT 0-160 PSI back mount pressure gauge	\$6.60
	GP-2-160-02	2" Dia. 1/4" NPT 0-160 PSI panel mount pressure gauge	\$7.60
	GA-1 1/2-60-01	1.5" Dia. 1/8" NPT 0-60 PSI SS housing back mount glycerin filled	\$10.56
GA-1 1/2-160-01	1.5" Dia. 1/8" NPT 0-160 PSI SS housing back mount glycerin filled	\$10.56	
	VHS2000-01	1/8" NPT Relieving Shut-off /Lockout Valve for 2000-01 Series FRL	\$22.26
	VHS2000-02	1/4" NPT Relieving Shut-off /Lockout Valve for 2000-02 Series FRL	\$22.26
	VHS3000-02	1/4" NPT Relieving Shut-off /Lockout Valve for 3000-02 Series FRL	\$28.36
	VHS3000-03	3/8" NPT Relieving Shut-off /Lockout Valve for 3000-03 Series FRL	\$28.36
	VHS4000-03	3/8" NPT Relieving Shut-off /Lockout Valve for 4000-03 Series FRL	\$42.26
	VHS4000-04	1/2" NPT Relieving Shut-off /Lockout Valve for 4000-04 Series FRL	\$42.26
	VHS4000-06	1/2" NPT Relieving Shut-off /Lockout Valve for 4000-06 Series FRL	
	VHS5000-10	1/2" NPT Relieving Shut-off /Lockout Valve for 5000 Series FRL	

# Filter-Regulator-Lubricator Air Flow Charts

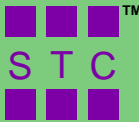

## Filter Regulator Lubricator Selection:

1. Determine flow rate requirements.
2. Determine required set point pressure and allowable pressure drop.
3. Locate the FRL graph with set point pressure that provides the flow rate with acceptable pressure drop.

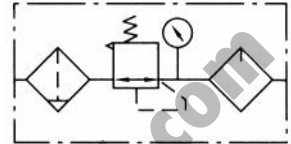

AC1000 Series Filter Regulator Lubricator  
Flow Rate VS Set Point Pressure  
Supply Pressure 100 PSI

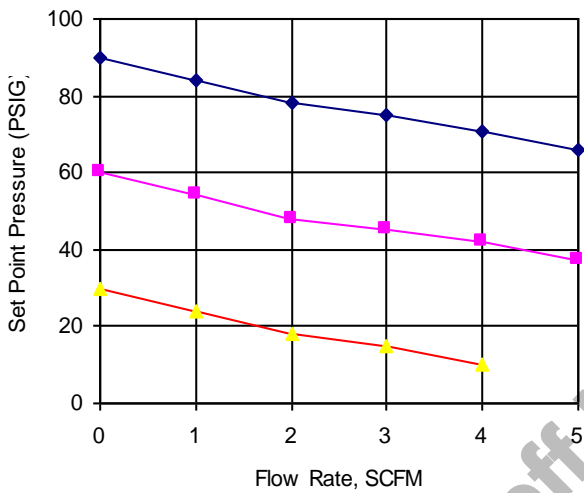

AC2000 Series Filter Regulator Lubricator  
Flow Rate VS Set Point Pressure  
Supply Pressure 100 PSI

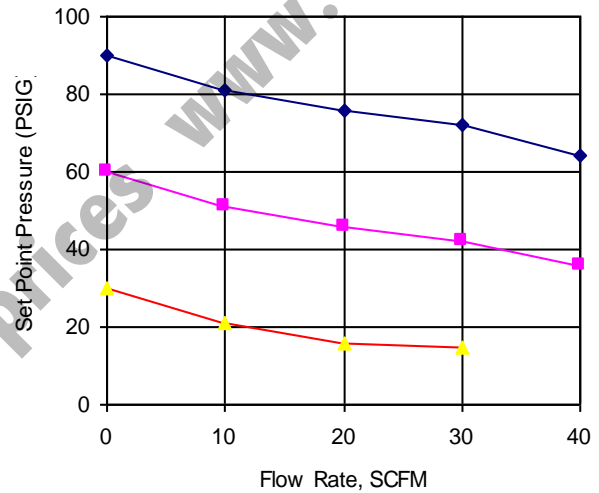

AC3000 Series Filter Regulator Lubricator  
Flow Rate VS Set Point Pressure  
Supply Pressure 100 PSI

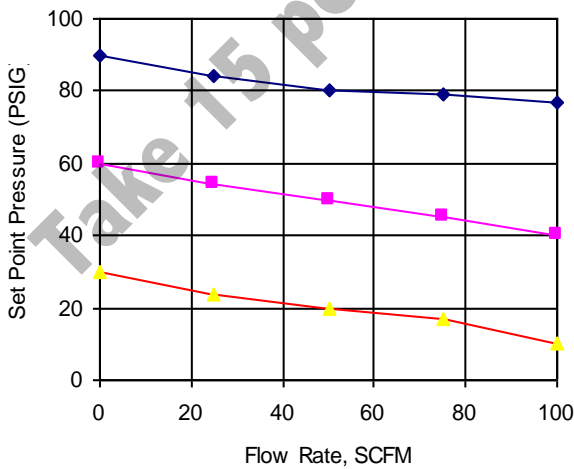

AC4000 Series Filter Regulator Lubricator  
Flow Rate VS Set Point Pressure  
Supply Pressure 100 PSI

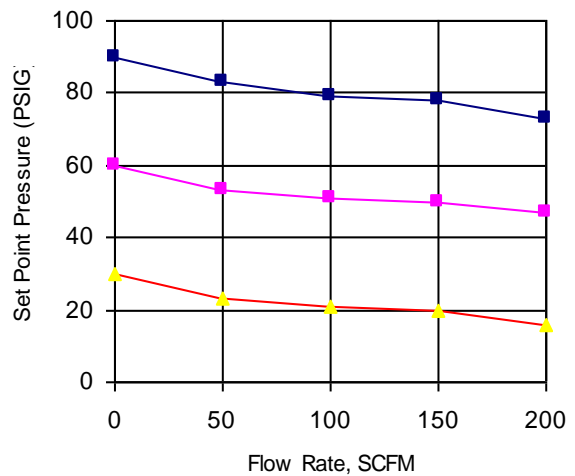



### Filter Selection:

1. Determine flow rate requirements.
2. Determine required set point pressure and allowable pressure drop.
3. Locate the FRL graph with set point pressure that provides the flow rate with acceptable pressure drop.

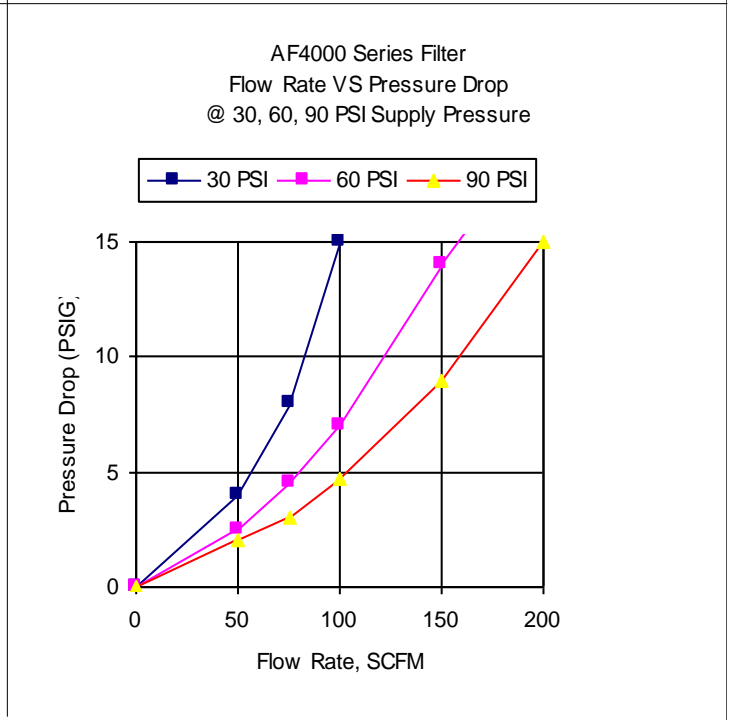
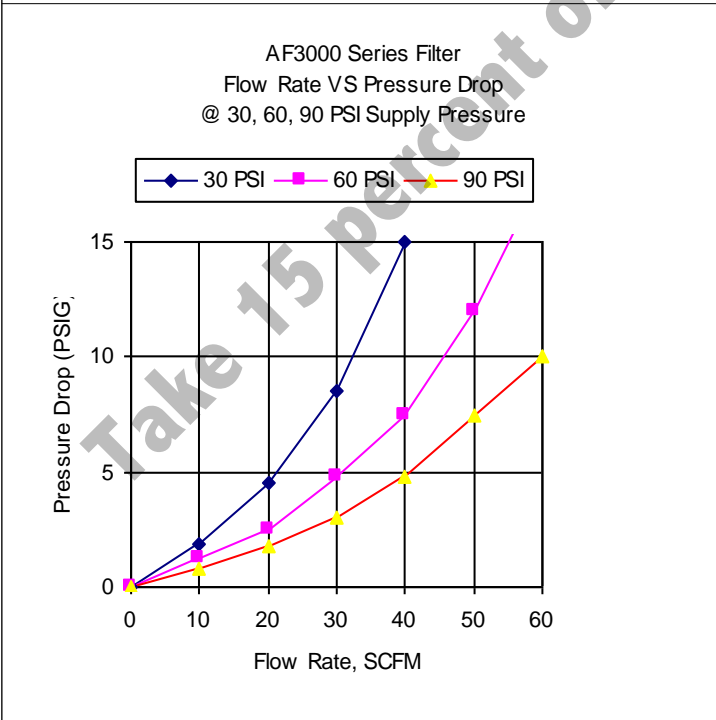
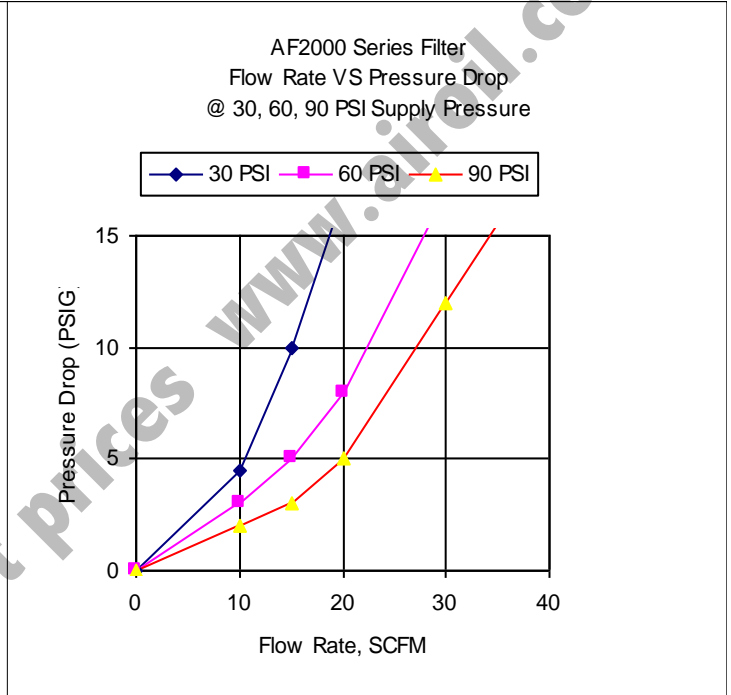
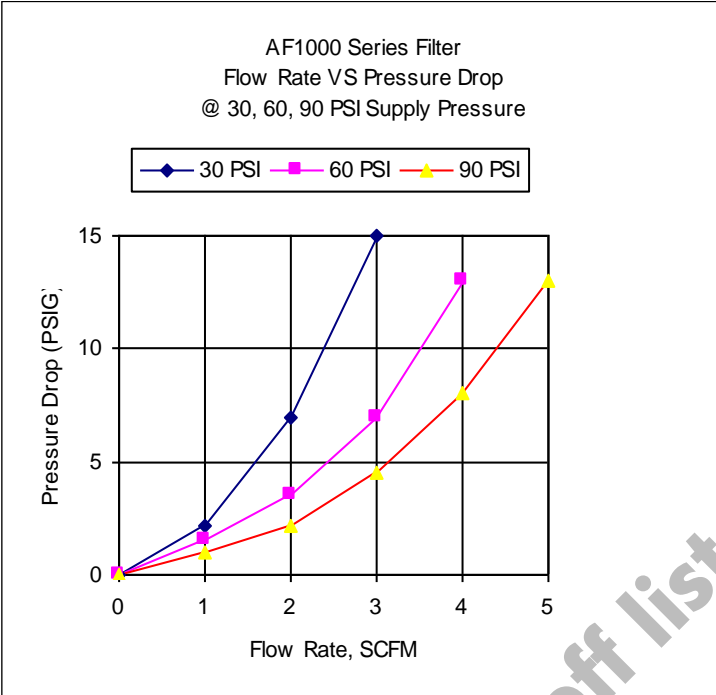
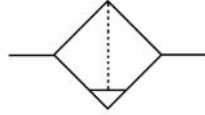



# Air Regulator Flow Charts

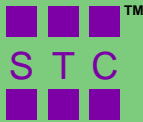

## Regulator Selection:

1. Determine flow rate requirements.
2. Determine required set point pressure and allowable pressure drop.
3. Locate the FRL graph with set point pressure that provides the flow rate with acceptable pressure drop.

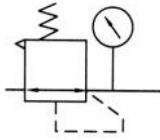

AR1000 Series Pressure Regulator  
Flow Rate VS Set Point Pressure  
Supply Pressure 100 PSI

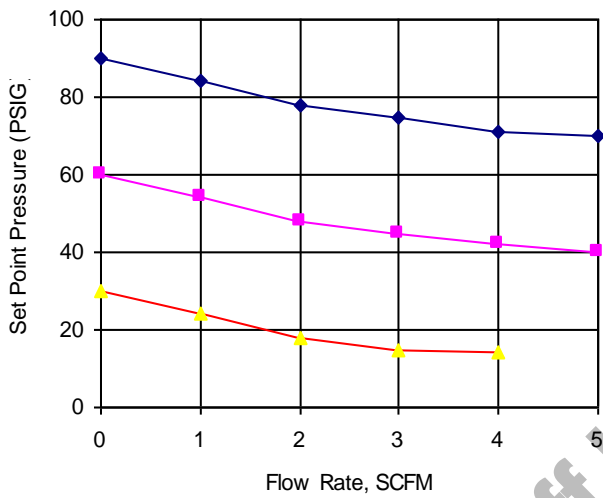

AR2000 Series Pressure Regulator  
Flow Rate VS Set Point Pressure  
Supply Pressure 100 PSI

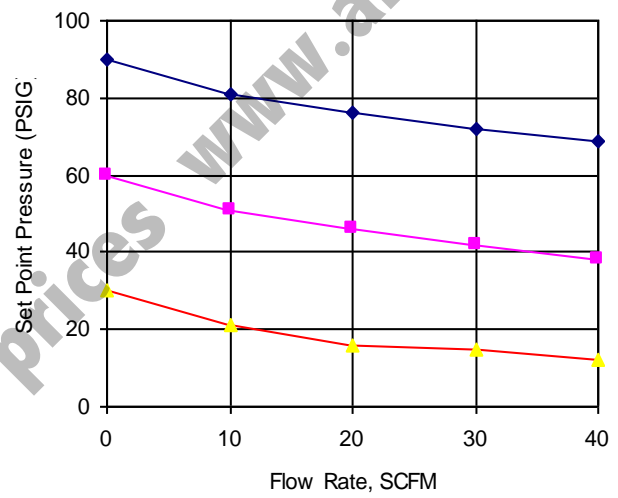

AR3000 Series Pressure Regulator  
Flow Rate VS Set Point Pressure  
Supply Pressure 100 PSI

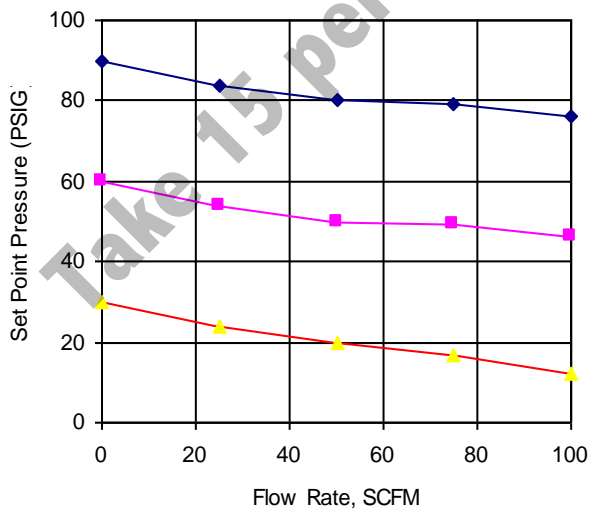

AR4000 Series Pressure Regulator  
Flow Rate VS Set Point Pressure  
Supply Pressure 100 PSI

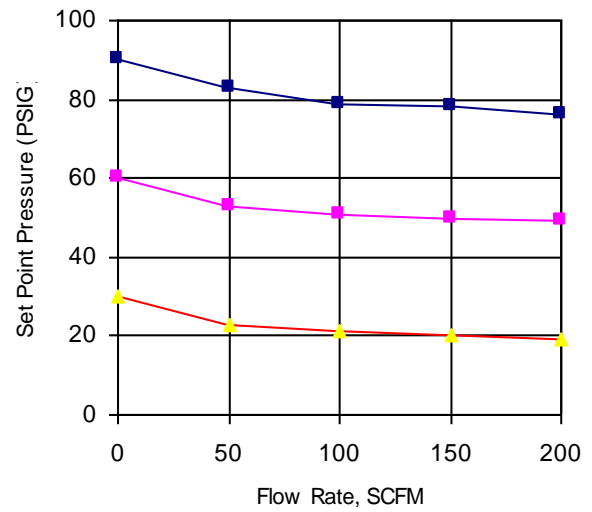

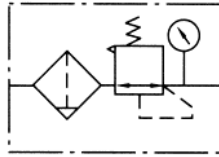

### Filter Regulator Selection:

1. Determine flow rate requirements.
2. Determine required set point pressure and allowable pressure drop.
3. Locate the FRL graph with set point pressure that provides the flow rate with acceptable pressure drop.

A W1000 Series Filter Regulator  
Flow Rate VS Set Point Pressure  
Supply Pressure 100 PSI

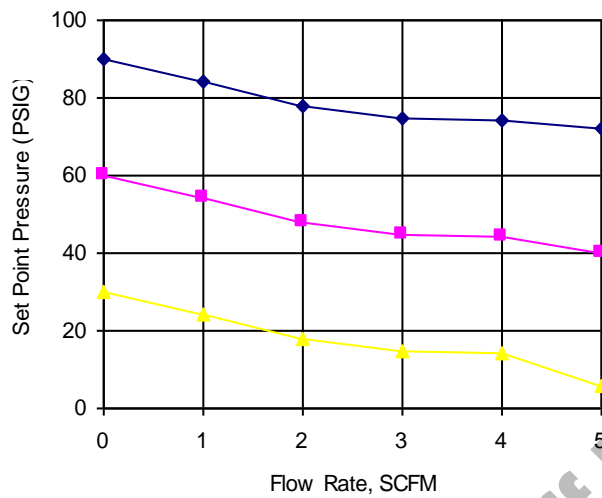

AW2000 Series Filter Regulator  
Flow Rate VS Set Point Pressure  
Supply Pressure 100 PSI

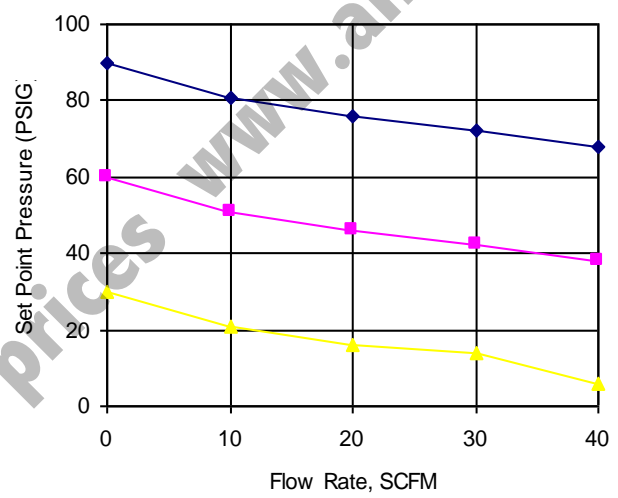

AW3000 Series Filter Regulator  
Flow Rate VS Set Point Pressure  
Supply Pressure 100 PSI

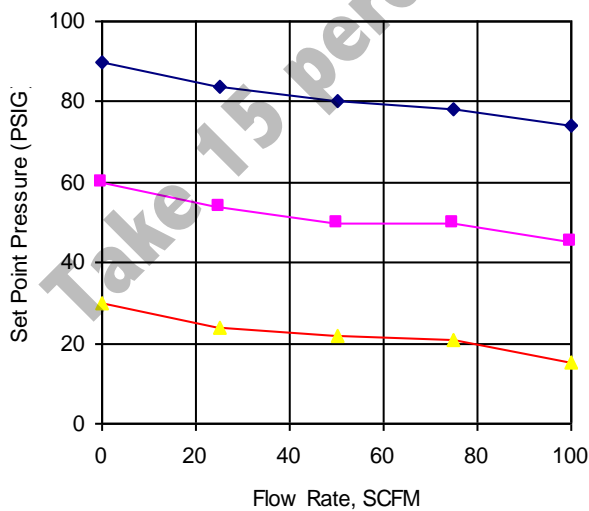

AW4000 Series Filter Regulator  
Flow Rate VS Set Point Pressure  
Supply Pressure 100 PSI

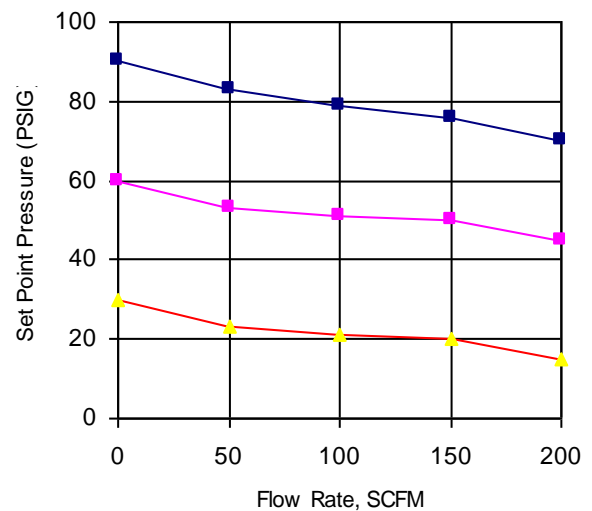

**Filter Regulator Lubricator Selection:**

1. Determine flow rate requirements.
2. Determine required set point pressure and allowable pressure drop.
3. Locate the FRL graph with set point pressure that provides the flow rate with acceptable pressure drop.

AC5000 Series Filter Regulator Lubricator  
Flow Rate VS Set Point Pressure  
Supply Pressure 100 PSI

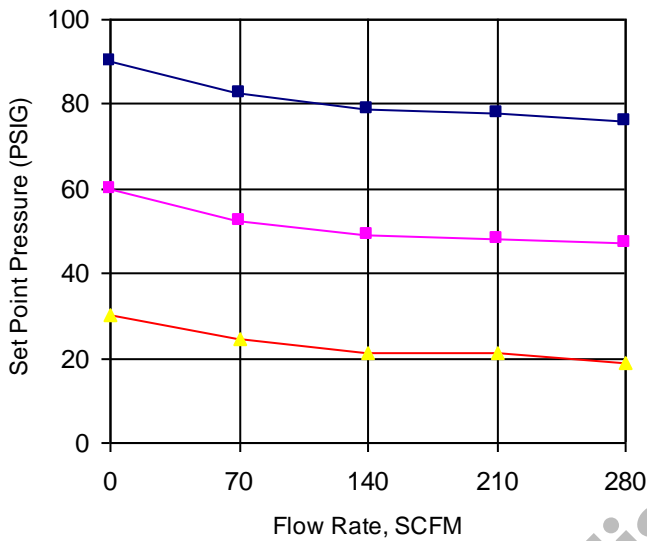

AW5000 Series Filter Regulator  
Flow Rate VS Set Point Pressure  
Supply Pressure 100 PSI

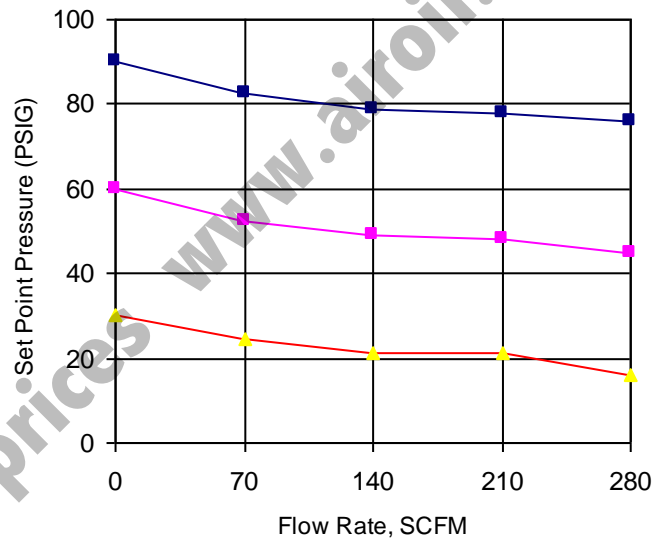

AF5000 Series Filter  
Flow Rate VS Pressure Drop  
@ 30, 60, 90 PSI Supply Pressure

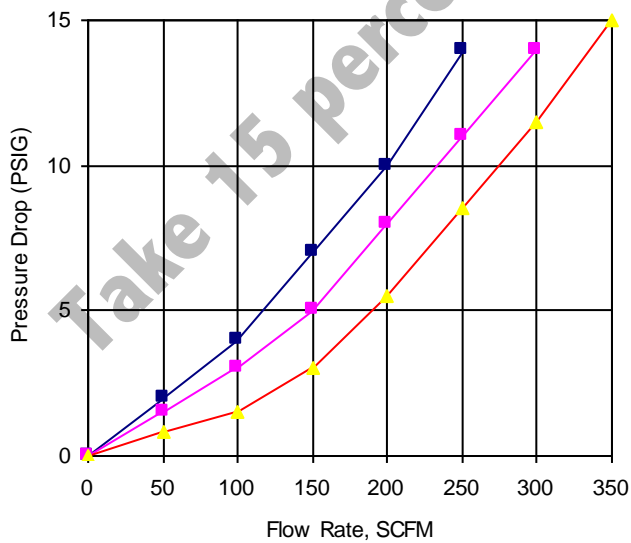

AR5000 Series Pressure Regulator  
Flow Rate VS Set Point Pressure  
Supply Pressure 100 PSI

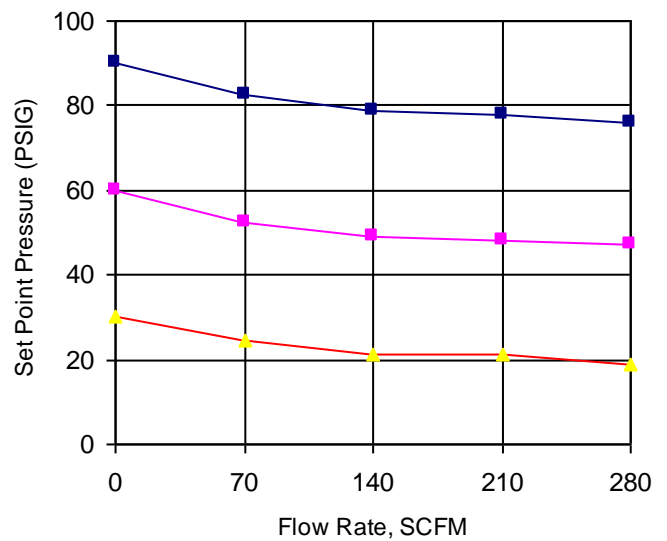

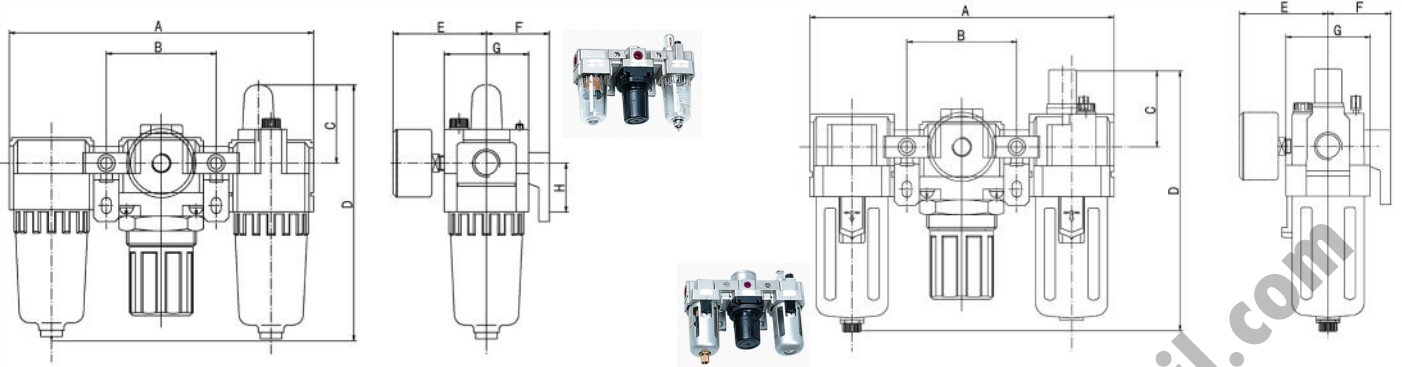

Model	Flow Rate (lpm/scfm)	Port	Gauge Port	A (mm/in)	B (mm/in)	C (mm/in)	D (mm/in)	E (mm/in)	F (mm/in)	G (mm/in)	H (mm/in)	Bracket	Weight (kg/lb)	Gauge
AC1000-00	90	10-32 (M5)	1/16 Rc	91	33	25.5	84.5	26	25	25	20	Y10L	0.26	GE-1-160-00
	3			3.58	1.30	1.00	3.33	1.02	0.98	0.98	0.79		0.57	
AC2000-01	500	1/8 NPT	1/8 NPT	140	50	38	125	56.8	30	40	24	Y20L	0.74	GE-1 1/2-160-01
AC2000-02	18	1/4 NPT		5.51	1.97	1.50	4.92	2.24	1.18	1.57	0.94		1.63	
AC3000-02	2000	1/4 NPT	1/8 NPT	181	64	38	156.5	60.8	41	53	35	Y30L	1.18	GE-1 1/2-160-01
AC3000-03	70	3/8 NPT		7.13	2.52	1.50	6.16	2.39	1.61	2.09	1.38		2.60	
AC4000-03	4000	3/8 NPT	1/4 NPT	238	84	41	191.5	65.5	50	70	40	Y40L	2.14	GE-2-160-02
AC4000-04	140	1/2 NPT		9.37	3.31	1.61	7.54	2.58	1.97	2.76	1.57		4.71	
AC4000-06	4500	3/4 NPT	1/4 NPT	253	89	41	193	69.5	50	70	40	Y50L	2.47	GE-2-160-02
	160			9.96	3.50	1.61	7.60	2.74	1.97	2.76	1.57		5.43	
AC5000-06	5000	3/4 NPT	1/4 NPT	300	105	48	271.5	75.5	69.8	90	50	Y60L	3.82	GE-2-160-02
AC5000-10	180	1 NPT		11.81	4.13	1.89	10.69	2.97	2.75	3.54	1.97		8.40	

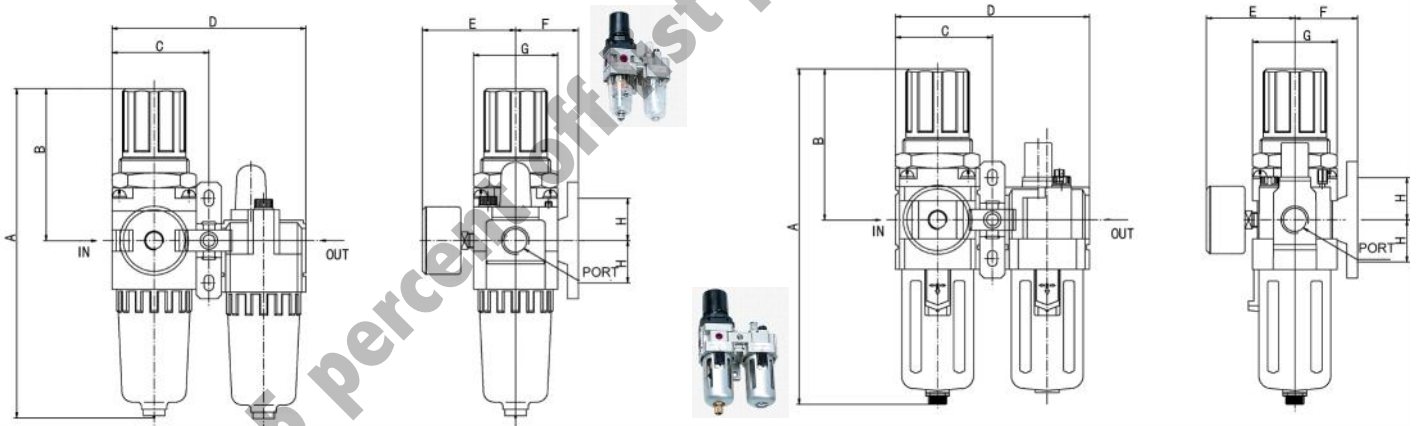

Model	Flow Rate (lpm/scfm)	Port	Gauge Port	A (mm/in)	B (mm/in)	C (mm/in)	D (mm/in)	E (mm/in)	F (mm/in)	G (mm/in)	H (mm/in)	Bracket	Weight (kg/lb)	Gauge
AC1010-00	90	10-32 (M5)	1/16 Rc	109.5	50.5	29	58	26	25	25	20	Y10T	0.22	GE-1-160-00
	3			4.31	1.99	1.14	2.28	1.02	0.98	0.98	0.79		0.48	
AC2010-01	500	1/8 NPT	1/8 NPT	164.5	78	45	90	56.8	30	40	24	Y20T	0.66	GE-1 1/2-160-01
AC2010-02	18	1/4 NPT		6.48	3.07	1.77	3.54	2.24	1.18	1.57	0.94		1.45	
AC3010-02	1700	1/4 NPT	1/8 NPT	211	92.5	58.5	117	60.8	41	53	35	Y30T	0.98	GE-1 1/2-160-01
AC3010-03	60	3/8 NPT		8.31	3.64	2.30	4.61	2.39	1.61	2.09	1.38		2.16	
AC4010-03	3000	3/8 NPT	1/4 NPT	262	112	77	154	65.5	50	70	40	Y40T	1.93	GE-2-160-02
AC4010-04	105	1/2 NPT		10.31	4.41	3.03	6.06	2.58	1.97	2.76	1.57		4.25	
AC4010-06	3000	3/4 NPT	1/4 NPT	267	114	82	164	69.5	50	70	40	Y50T	1.99	GE-2-160-02
	105			10.51	4.49	3.23	6.46	2.74	1.97	2.76	1.57		4.38	
AC5010-06	4000	3/4 NPT	1/4 NPT	338	116	97.5	195	75.5	69.8	90	50	Y60T	3.2	GE-2-160-02
AC5010-10	140	1 NPT		13.31	4.57	3.84	7.68	2.97	2.75	3.54	1.97		7.04	

# Air Filter Regulator Lubricator Dimensions

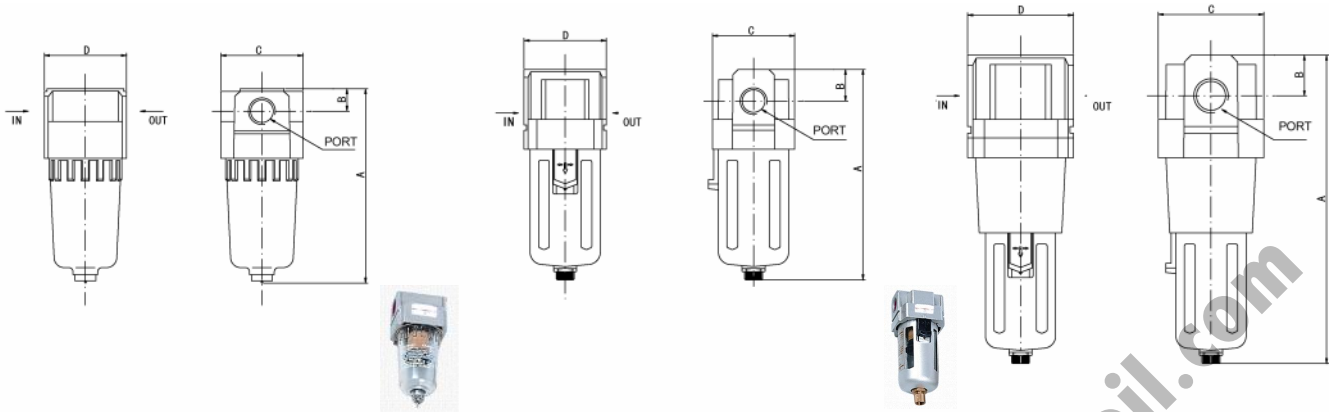
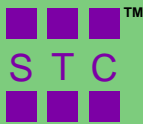

Model	Flow Rate (lpm/scfm)	Port	A (mm/in)	B (mm/in)	C (mm/in)	D (mm/in)	Bracket/Screw	Weight (kg/lb)
AF1000-00	110	10-32 (M5)	66	7	25	0.00	B140	0.07
	4		2.60	0.28	0.98			0.15
AF2000-01	750	1/8 NPT	97.5	11	40	40	B240/M4x8	0.19
AF2000-02	26	1/4 NPT	3.84	0.43	1.57	1.57		0.42
AF3000-02	2000	1/4 NPT	132.5	14	53	53	B340/M4x8	0.29
AF3000-03	70	3/8 NPT	5.22	0.55	2.09	2.09		0.64
AF4000-03	4000	3/8 NPT	168.5	18	70	70	B440/M5x10	0.55
AF4000-04	140	1/2 NPT	6.63	0.71	2.76	2.76		1.21
AF4000-06	6000	3/4 NPT	172.5	20	70	70	B540/M5x10	0.58
	210		6.79	0.79	2.76	2.76		1.28
AF5000-06	7000	3/4 NPT	247.5	24	90	90	B640/M6x10	1.08
AF5000-10	245	1 NPT	9.74	0.94	3.54	3.54		2.38

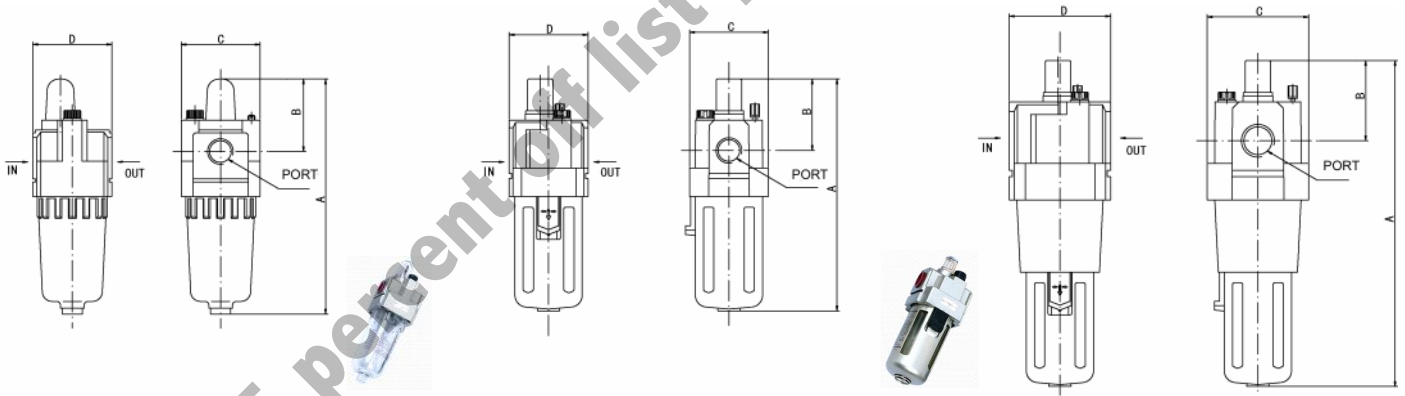

Model	Flow Rate (lpm/scfm)	Port	A (mm/in)	B (mm/in)	C (mm/in)	D (mm/in)	Bracket/Screw	Weight (kg/lb)
AL1000-00	95	10-32 (M5)	81.5	25.5	25	0.00	B140	0.07
	3		3.21	1.00	0.98			0.15
AL2000-01	800	1/8 NPT	122	38	40	40	B240/M4x8	0.22
AL2000-02	28	1/4 NPT	4.80	1.50	1.57	1.57		0.48
AL3000-02	1700	1/4 NPT	142	38	53	53	B340/M4x8	0.3
AL3000-03	60	3/8 NPT	5.59	1.50	2.09	2.09		0.66
AL4000-03	5000	3/8 NPT	177	41	70	70	B440/M5x10	0.56
AL4000-04	180	1/2 NPT	6.97	1.61	2.76	2.76		1.23
AL4000-06	6300	3/4 NPT	177	39	70	70	B540/M5x10	0.58
	220		6.97	1.54	2.76	2.76		1.28
AL5000-06	7000	3/4 NPT	254	45	90	90	B640/M6x10	1.08
AL5000-10	245	1 NPT	10.00	1.77	3.54	3.54		2.38



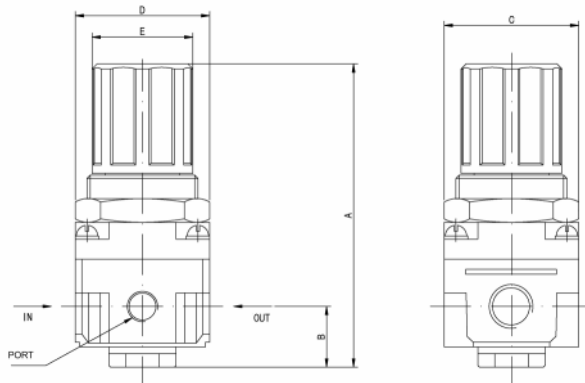

Model	Flow Rate (lpm/scfm)	Port	Gauge Port	A (mm/in)	B (mm/in)	C (mm/in)	D (mm/in)	E (mm/in)	Panel Cut Hole (mm/in)	Bracket	Weight (kg/lb)	Gauge
AR1000-00	100	10-32 (M5)	1/16 Rc	61.5	11	25	25	20	20.5	B120	0.08	GE-1-160-00
	4			2.42	0.43	0.98	0.98	0.79	0.81		0.18	
AR2000-01	550	1/8 NPT	1/8 NPT	95	17	40	40	34	33.5	B220	0.27	GE-1 1/2-160-01
AR2000-02	19	1/4 NPT		3.74	0.67	1.57	1.57	1.34	1.32		0.59	
AR2500-02	2000	1/4 NPT		102.5	25	48	53	34	33.5			
AR2500-03	70	3/8 NPT	1/8 NPT	4.04	0.98	18.9	2.09	1.34	1.32	B320	0.41	GE-1 1/2-160-01
AR3000-02	2500	1/4 NPT		127.5	35	53	53	40	42.5		0.90	
AR3000-03	88	3/8 NPT	1/4 NPT	5.02	1.38	2.09	2.09	1.57	1.67	B420	0.84	GE-2-160-02
AR4000-03	6000	3/8 NPT		149.5	37.5	70	70	54	52.5		1.85	
AR4000-04	210	1/2 NPT	1/4 NPT	5.89	1.48	2.76	2.76	2.13	2.07	B420	0.84	GE-2-160-02
AR4000-06	6000	3/4 NPT		154	40.5	70	75	54	52.5		1.85	
AR5000-06	8000	3/4 NPT	1/4 NPT	6.06	1.59	2.76	2.95	2.13	2.07	B420	1.19	GE-2-160-02
AR5000-10	280	1 NPT		168	48	90	90	54	52.5		2.62	
				6.61	1.89	3.54	3.54	2.13	2.07			

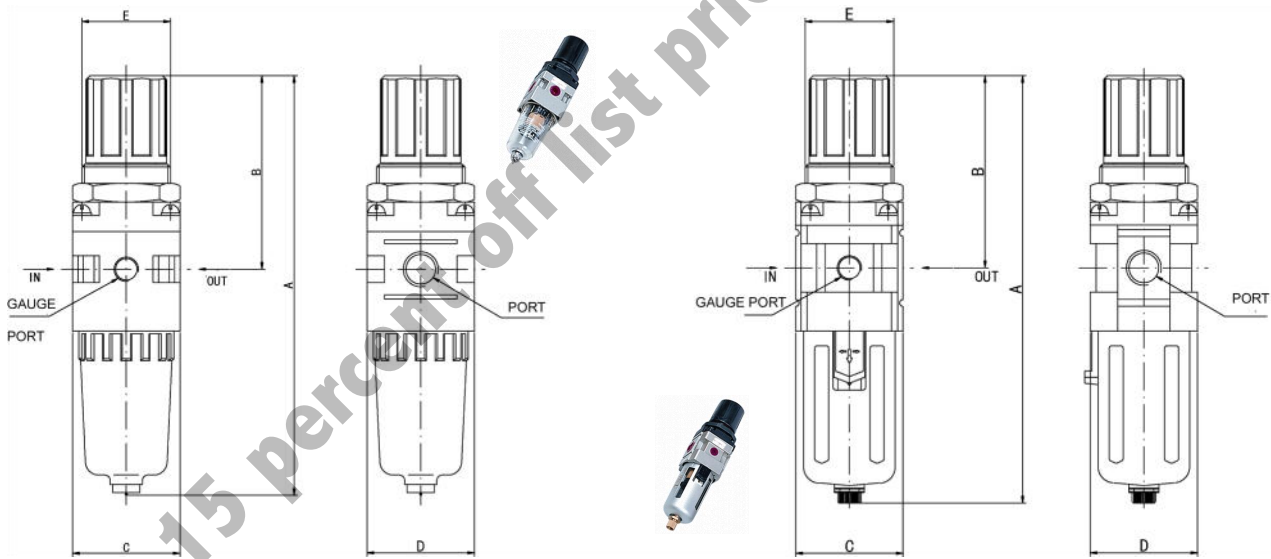

Model	Flow Rate (lpm/scfm)	Port	Gauge Port	A (mm/in)	B (mm/in)	C (mm/in)	D (mm/in)	E (mm/in)	Panel Cut Hole (mm/in)	Bracket	Weight (kg/lb)	Gauge
AW1000-00	90	10-32 (M5)	1/16 Rc	109.5	50.5	25	28	20	20.5	B120	0.09	GE-1-160-00
	3			4.31	1.99	0.98	1.10	1.10	0.81		0.20	
AW2000-01	550	1/8 NPT	1/8 NPT	164.5	78	40	40	34	33.5	B220	0.36	GE-1 1/2-160-01
AW2000-02	19	1/4 NPT		6.48	3.07	1.57	1.57	1.34	1.32		0.79	
AW3000-02	2000	1/4 NPT	1/8 NPT	211	92.5	53	53	40	33.5	B320	0.56	GE-1 1/2-160-01
AW3000-03	70	3/8 NPT		8.31	3.64	2.09	2.09	1.57	1.32		1.23	
AW4000-03	4000	3/8 NPT	1/4 NPT	262	112	70	70	54	42.5	B420	1.15	GE-2-160-02
AW4000-04	140	1/2 NPT		10.31	4.41	2.76	2.76	2.13	1.67		2.53	
AW4000-06	4500	3/4 NPT	1/4 NPT	267	114	70	75	54	42.5	B520	1.21	GE-2-160-02
	160			10.51	4.49	2.76	2.95	2.13	1.67		2.66	
AW5000-06	5500	3/4 NPT	1/4 NPT	338	116	90	90	54	42.5	B620	1.7	GE-2-160-02
AW5000-10	195	1 NPT		13.31	4.57	3.54	3.54	2.13	1.67		3.74	

# Air Filter Regulator Lubricator Dimensions

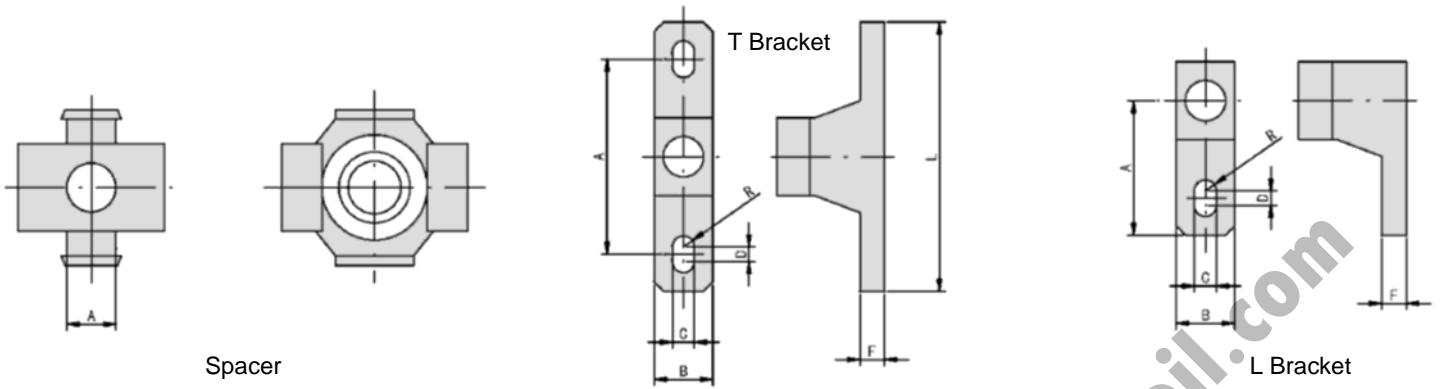

L Bracket	L Spacer Bracket	For	T Bracket	T Spacer Bracket	For	A	B	C	D	E	F	G	H	R	L
B110L	Y10L	AC1000	B110T	Y10T	AC1010	20	12	4.5	3	2.5	5	8	40	2.25	27
B210L	Y20L	AC2000	B210T	Y20T	AC2010	24	15	5.5	3	30	5	10	48	2.75	33
B310L	Y30L	AC3000	B310T	Y30T	AC3010	35	16	7	4	41	7	11	70	3.5	45
B410L	Y40L	AC4000	B410T	Y40T	AC4010	40	22	9	4	50	7	14	80	4.5	50
B510L	Y50L	AC4000-06	B510T	Y50T	AC4010-06	40	22	9	4	50	7	14	80	4.5	50
B610L	Y60L	AC5000	B610T	Y60T	AC5010	50	23	12	4	69.8	10.5	15	100	6	63

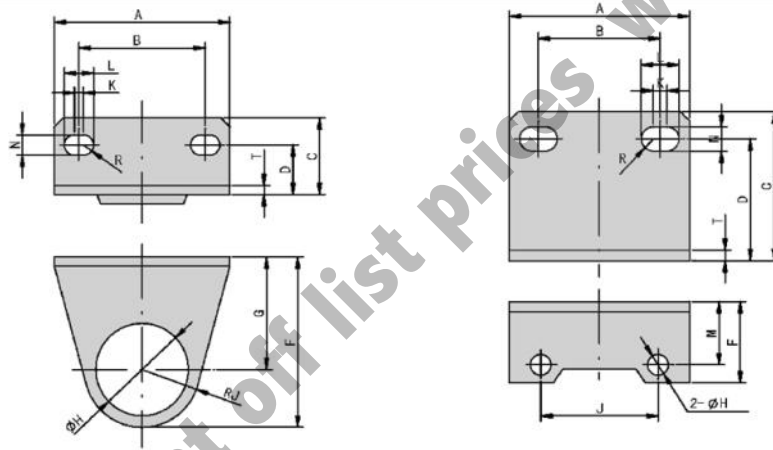

B#20 -Bracket for AR & AW

B#40 Bracket for AF/AL

in (MM)	A	B	C	D	F	G	H	J	K	L	M	N	R	t	Mounting Screw	For
B120	40	28	17	11	37.8	25	20.5	12.3	2	6.5		4.5	2.25	2		AR/AW1000
B220	55	34	35	19	50	30	33.5	20	10	5.4		5.4	2.7	2.3		AR/AW2000-2500
B320	53	40	21.5	14	64	39	42.5	25	1.5	6.5		6.5	3.25	2.3		AR/AW3000
B420	70	54	27	18	79.2	49.2	52.5	30	2	8.5		8.5	4.25	2.3		AR/AW4000-5000



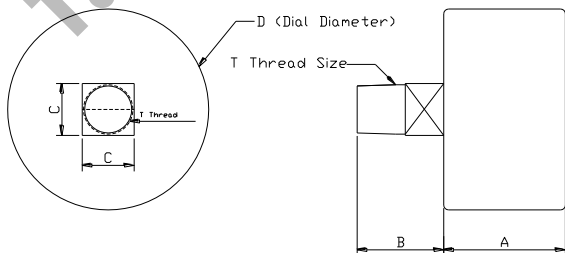





B240	40	27	33	27	18		4.5	26	3	8.4	14	5.4	2.7	2.3	M4X8	AF/AL2000
B340	53	40	39	32	22.5		4.5	35	1.5	8	19	6.5	3.25	2.3	M4X8	AF/AL3000
B440	70	54	47	38	31.5		5.5	47	2	10.5	20	8.5	4.25	2.3	M5X10	AF/AL4000-04
B540	70	54	47	38	31.5		5.5	47	2	10.5	20	8.5	4.25	2.3	M5X10	AF/AL4000-06
B640	90	66	64	52	43		6.5	60	2	13	29	11	5.5	3.2	M6X10	AF/AL5000

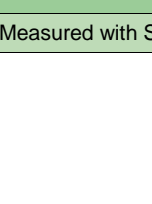

Pressure Gauge Part No.	For	(in/MM)				
		T Port Size	A	B	C	D
GE-1-160-00	AR1000	R1/16 (PT)	0.6/15.3	0.4/10	0.47/12	1.0/25.4
GE-1 1/2-160-01	AR2000-3000	1/8 NPT	0.93/23.8	0.67/17.0	0.43/11	1.6/42
GE-2-160-02	AR4000-5000	1/4 NPT	0.97/24.8	0.77/19.7	0.54/14	2.1/52.4

These FRL components are of modular design with joiner clamps. The joiner clamps allow easy connection and disconnection of FRL components for simple installation and maintenance.

**Interchangeable with SMC - NAC SERIES FRL**









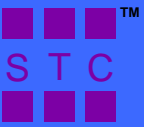





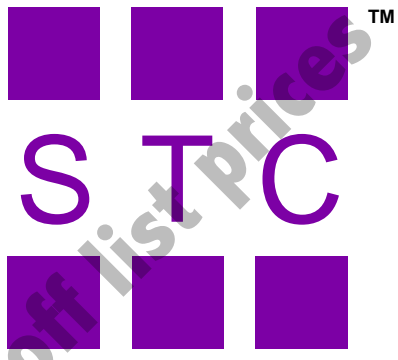

	Regulator-Filter-Lubricator	AC1000-00	AC2000-XX	AC3000-XX	AC4000-XX	AC4000-06	AC5000-XX	
	Air Flow Rate* SCFM (LPM)	3 (90)	18 (500)	70 (2000)	140 (4000)	160 (4500)	180 (5000)	
	Stacking Regulator-Filter-Lubricator	AC1010-00	AC2010-XX	AC3010-XX	AC4010-XX	AC4010-06	AC5010-XX	
	Air Flow Rate* SCFM (LPM)	3 (90)	18 (500)	60 (1700)	105 (3000)	105 (3000)	140 (4000)	
	Stacking Regulator-Filter	AW1000-00	AW2000-XX	AW3000-XX	AW4000-XX	AW4000-06	AW5000-XX	
	Air Flow Rate* SCFM (LPM)	3 (90)	19 (550)	70 (2000)	140 (4000)	160 (4500)	195 (5500)	
	Regulators	AR1000-00	AR2000-XX	AR3000-XX	AR4000-XX	AR4000-06	AR5000-XX	
	Air Flow Rate* SCFM (LPM)	4 (100)	19 (550)	88 (2500)	210 (6000)	210 (6000)	280 (8000)	
	Filters	AF1000-00	AF2000-XX	AF3000-XX	AF4000-XX	AF4000-06	AF5000-XX	
	Air Flow Rate* SCFM (LPM)	4 (110)	26 (750)	70 (2000)	140 (4000)	210 (6000)	245 (7000)	
	Lubricators	AL1000-00	AL2000-XX	AL3000-XX	AL4000-XX	AL4000-06	AL5000-XX	
	Air Flow Rate* SCFM (LPM)	3 (90)	28 (800)	60 (1700)	180 (5000)	220 (6300)	245 (7000)	
	Port Size	10-32 (M5)	1/8 or 1/4 NPT	1/4 or 3/8 NPT	3/8 or 1/2 NPT	3/4 NPT	3/4 or 1 NPT	
	Port Size (Pressure Gauge)	1/16 Rc (PT)	1/8 NPT	1/8 NPT	1/4 NPT	1/4 NPT	1/4 NPT	
	Regulating Range	7-100 PSI	7-125 PSI (0.5-8.5 kgf/cm <sup>2</sup> )					
	Max. Operating Pressure	150 PSI (9.9 kgf/cm <sup>2</sup> )						
	Operating Temperature	40-140°F (5-60°C)						
	Filtration	5 micron filter (Option); 25 Micron (Standard Sintered Brass Filter)						
	Bowl Material	Polycarbonate (standard) or Aluminum Metal (Option)						
	Bowl Guard	N/A	Steel Bowl Guard					
	Body Material	Die-Casting Aluminum						
	Construction/Regulator	Relieving Type						
	Seals	NBR						
	Filter Drain	Semi-Auto Differential Drain				Semi-Auto Differential Drain (Standard) or Automatic Drain		
	Service	Air				Air		

\*Measured with Supply Air Pressure @100 PSI and Set Point Pressure @ 75 PSI

Take 15 percent off list prices

# Air Solenoid & Air Pilot Valves



				
	<p>Fine Quality</p>  <p>Advanced Design</p>			
	<p>Precision Engineered</p> <p>Excellent Prices</p>			
				
				

## Contents

STC Air Solenoid Valve and Valve Manifold Numbering System.....	C2
STC Air Solenoid Valve List Price.....	C3
Coil List Price.....	C3
Air Pilot Valve List Price.....	C4
Integrated Aluminum Base Mounted Manifolds.....	C4
Air Solenoid Valve and Air Pilot Valve Specifications.....	C4
Air Solenoid and Air Pilot Valves, & Manifold Dimensions.....	C5-8

## STC Solenoid Valve Numbering System

Ordering Part No. =  
(eg. 4V110-06-1-D)



Model	Valve Size	Solenoid/Position	Port Size (NPT)	Mounting	Voltage	Elec. Terminal
<b>Spool Valves:</b> 3A = 3 way air pilot valve 3V = 3 way solenoid valve 4A = 4 way air pilot valve 4V = 4 way solenoid valve	1 = 0.67 Cv 2 = 0.89 Cv 3 = 1.68 Cv 4 = 2.78 Cv	10 = 1 solenoid 2 position 20 = 2 solenoid 2 position 30C = 2 solenoid 3 position (Closed Center) 30E = 2 solenoid 3 position (Exhausted Center) 30P = 2 solenoid 3 position (Pressure Center)	05 = 10-32 06 = 1/8 08 = 1/4 10 = 3/8 15 = 1/2	Blank = Standard B = Namur Mounting/ Actuator Mounting	1 = 12 VDC 2 = 24 VDC 2A = 24 VAC 3 = 110 VAC 4 = 220VAC (50/60Hz)	D = DIN G = Grommet E = Explosion Proof
<b>Direct Acting Valves</b>						
2P025 = 2 way direct acting 2V025 = 2 way direct acting 2P035 = 3 way direct acting 2V035 = 3 way direct acting			06 = 1/8 08 = 1/4		1 = 12 VDC 2 = 24 VDC 2A = 24 VAC 3 = 110 VAC 4 = 220VAC (50/60Hz)	D = DIN G = Grommet E = Explosion Proof

## STC Valve Manifold Numbering System \*

Ordering Part No. =  
(eg. 4V100M-2)

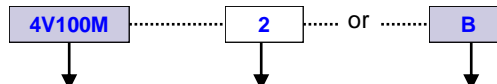

Model	No. of Stations	Blank Plate
3V100M = Manifold for 3V100 series valves		
3V200M = Manifold for 3V200 series valves		
3V300M = Manifold for 3V300 series valves		
3V400M = Manifold for 3V400 series valves		
4V100M = Manifold for 4V100 series valves	2	B = Blank plate G = Gasket and mounting hardware
4V200M = Manifold for 4V200 series valves	4	
4V300M = Manifold for 4V300 series valves	6	
4V400M = Manifold for 4V400 series valves	8	
	16	
* gasket and mounting hardware included		



# Air Solenoid Valve List Price







To Order, Please Specify: 1) Model No., 2) Voltage, & 3) Electrical Entry Options							
	Part No.	Price	Voltage & Electrical Connection Options B. Electrical Connection	Port Size (NPT)	# Way/Port/Position/ Solenoid	Cv	Power
	2V025-1/8	\$18.81	Voltage Options: 1 = 12 VDC 2 = 24VDC  2A=24VAC 3 = 110VAC 4 = 220VAC (50/60Hz)  B. Terminal Options:  D = DIN (with LED indicator & Conduit Terminal)  G = Grommet (12" Lead Wire)  E = Explosion Proof	1/8	2/2/2/1 Direct Acting	0.23	3W to 6.5 W
	2V025-1/4	\$18.81		1/4	3/2/2/1 Direct Acting	0.05	
	2V035-1/8	\$18.81		1/8			
	2V035-1/4	\$18.81		1/4			
	2P025-1/8	\$18.43		1/8	2/2/2/1 Direct Acting	0.23	
	2P025-1/4	\$18.43		1/4	3/2/2/1 Direct Acting	0.05	
	2P035-1/8	\$18.43		1/8			
	2P035-1/4	\$18.43		1/4	2/2/2/1 Direct Acting	0.23	
	2V1-1/8	\$18.81		1/8			
	3V1-1/8	\$18.81		1/8	3/2/2/1 Direct Acting	0.05	3W to 4.8 W
	3V110-1/8	\$24.26		1/8	3/3/2/1	0.67	
3V210-1/4	\$24.26	1/4, 1/8 (Exh)		0.89			
3V310-3/8	\$32.67	3/8, 1/4 (Exh)		1.68			
	3V410-1/2	\$56.93		1/2	3/3/2/2	2.79	
	3V120-1/8	\$37.16		1/8		0.67	
	3V220-1/4	\$37.16		1/4, 1/8 (Exh)		0.89	
	3V320-3/8	\$45.54		3/8, 1/4 (Exh)	4/5/2/1	1.68	
	3V420-1/2	\$79.70		1/2		2.79	
	4V110-1/8	\$25.25		1/8		0.67	2.5 W
	4V210-1/4	\$24.26		1/4, 1/8 (Exh)	4/5/2/1	0.89	3W to 4.8 W
	4V310-3/8	\$32.67		3/8, 1/4 (Exh)		1.68	
	4V410-1/2	\$56.93		1/2		2.79	
	4V310B-1/4	\$37.62		1/4	3/3/2/1	1.68	
	4V310B-1/4	\$37.62		1/4	4/5/2/1	1.68	
	4V310B-3/8	\$37.62	3/8, 1/4 (Exh)	1.68			
	4V120-1/8	\$37.13	1/8	4/5/2/2	0.67	3W to 4.8 W	
	4V220-1/4	\$37.13	1/4, 1/8 (Exh)		0.89		
	4V320-3/8	\$45.54	3/8, 1/4 (Exh)		1.68		
	4V420-1/2	\$79.70	1/2	4/5/3/2 Closed Center	2.79		
	4V130C-1/8	\$64.35	1/8		0.5		2.5 W
	4V230C-1/4	\$64.35	1/4, 1/8 (Exh)		4/5/3/2 Closed Center		0.67
4V330C-3/8	\$88.61	3/8, 1/4 (Exh)	1				
	4V430C-1/2	\$113.85	1/2	1.68			
	4V130P-1/8	\$64.35	1/8	4/5/3/2 Pressure Center	0.5	2.5 W	
	4V230P-1/4	\$64.35	1/4, 1/8 (Exh)		0.67	3W to 4.8 W	
4V330P-3/8	\$88.61	3/8, 1/4 (Exh)	1				
	4V430P-1/2	\$113.85	1/2	1.68			
	4V130E-1/8	\$64.35	1/8	4/5/3/2 Exhaust Center	0.5	2.5 W	
	4V230E-1/4	\$64.35	1/4, 1/8 (Exh)		0.67	3W to 4.8 W	
4V330E-3/8	\$88.61	3/8, 1/4 (Exh)	1				
	4V430E-1/2	\$113.85	1/2	1.68			

	Part No.	Price	Voltage Options	Electrical	Power	Specifications
	100C	\$7.92	Voltage Options: 1 = 12 VDC 2 = 24VDC 2A=24VAC 3 = 110VAC 4 = 220VAC	D = DIN (with LED indicator, conduit terminal)	2.5 W	Insulation: F Class IP65;  Duty Cycle: 100% ED;  CE Certification
	200C	\$7.92			3-4.8W	
	100C	\$7.13		G = Grommet (12" Lead Wire)	2.5 W	
	200C	\$7.13			3-4.8W	



To connect DIN coil:  
 1. Remove the Philip screw from the plastic housing and unplug it from the DIN coil.  
 2. From the screw opening, use the screw to push the terminal block out of the plastic housing.  
 3. Note the 1, 2 and ground markings on underside of DIN enclosure.  
 4. For DC DIN Coil, Connect 1 to Positive, 2 to Negative.  
 5. For AC DIN Coil, connect 1 to HOT wire, 2 to Neutral wire, and if required connect ground to ground wire.  
 To connect Grommet coil:  
 1. For DC Coil, connect one of the two wires to Positive, and the other wire to Negative.  
 2. For AC Coil, connect one of the two wires to HOT wire, and the other wire to neutral wire.

## Air Pilot Valve List Price

	Part No.	Price	Port Size (NPT)	# Ways/Port/Position/Pilot	Cv		Part No.	Price	Port Size (NPT)	# Ways/Port/Position/Pilot	Cv
	3A110-1/8	\$18.81	1/8	3/3/2/1	0.67		4A130C-1/8	\$49.01	1/8	4/5/3/2 Closed Center	0.5
	3A210-1/4	\$18.81	1/4, 1/8		0.89		4A230C-1/4	\$49.01	1/4, 1/8 (Exh)		0.67
	3A310-3/8	\$22.77	3/8, 1/4		1.68		4A330C-3/8	\$71.78	3/8, 1/4 (Exh)		1
	3A410-1/2	\$37.62	1/2		2.79		4A430C-1/2	\$85.36	1/2		1.68
	3A120-1/8	\$23.76	1/8	3/3/2/2	0.67		4A130P-1/8	\$49.01	1/8	4/5/3/2 Pressure Center	0.5
	3A220-1/4	\$24.26	1/4, 1/8		0.89		4A230P-1/4	\$49.01	1/4, 1/8 (Exh)		0.67
	3A320-3/8	\$28.71	3/8, 1/4		1.68		4A330P-3/8	\$71.78	3/8, 1/4 (Exh)		1
	3A420-1/2	\$49.01	1/2		2.79		4A430P-1/2	\$85.36	1/2		1.68
	4A110-1/8	\$18.81	1/8	4/5/2/1	0.67		4A130E-1/8	\$49.01	1/8	4/5/3/2 Exhaust Center	0.5
	4A210-1/4	\$18.81	1/4, 1/8		0.89		4A230E-1/4	\$49.01	1/4, 1/8 (Exh)		0.67
	4A310-3/8	\$22.77	3/8, 1/4		1.68		4A330E-3/8	\$71.78	3/8, 1/4 (Exh)		1
	4A410-1/2	\$37.62	1/2		2.79		4A430E-1/2	\$85.36	1/2		1.68
	4A120-1/8	\$23.76	1/8	4/5/2/2	0.67						
	4A220-1/4	\$24.26	1/4, 1/8		0.89						
	4A320-3/8	\$28.71	3/8, 1/4		1.68						
	4A420-1/2	\$49.01	1/2		2.79						

## Integrated Aluminum Base Mounted Manifolds\*

To Order, Please Specify: 1) Model No., 2) Voltage, & 3) Electrical Entry Options

	Part No.	Number of Stations	Description		Part No.	Number of Stations	Description
	3V-100M-2	\$11.00/2 stations	Integrated Base for Mounting 3V100 or 3A100 series Solenoid Valves		4V-100M-2	\$11.00/2 station	Integrated Base for Mounting 4V100 or 4A100 series Solenoid Valves
	3V-100M-4	\$22.00/4 stations			4V-100M-4	\$22.00/4 station	
	3V-100M-6	\$33.00/6 stations			4V-100M-6	\$33.00/6 station	
	3V-100M-8	\$44.00/8 stations			4V-100M-8	\$44.00/8 stations	
	3V-100M-16	\$88.00/16 stations			4V-100M-16	\$88.00/16 stations	
	3V-100M-B	\$4.84/blank plate			4V-100M-B	\$4.84/blank plate	
	3V-200M-2	\$11.00/2 stations	Integrated Base for Mounting 3V200 or 3A200 series Solenoid Valves		4V-200M-2	\$11.00/2 stations	Integrated Base for Mounting 4V200 or 4A200 series Solenoid Valves
	3V-200M-4	\$22.00/4 stations			4V-200M-4	\$22.00/4 stations	
	3V-200M-6	\$33.00/6 stations			4V-200M-6	\$33.00/6 stations	
	3V-200M-8	\$44.00/8 stations			4V-200M-8	\$44.00/8 stations	
	3V-200M-16	\$88.00/16 stations			4V-200M-16	\$88.00/16 stations	
	3V-200M-B	\$4.84/blank plate			4V-200M-B	\$4.84/blank plate	
	3V-300M-2	\$16.50/2 stations	Integrated Base for Mounting 3V300 or 3A300 series Solenoid Valves		4V-300M-2	\$16.50/2 stations	Integrated Base for Mounting 4V300 or 4A300 series Solenoid Valves
	3V-300M-4	\$33.00/4 stations			4V-300M-4	\$33.00/4 stations	
	3V-300M-6	\$49.50/6 stations			4V-300M-6	\$49.50/6 stations	
	3V-300M-8	\$66.00/8 stations			4V-300M-8	\$66.00/8 stations	
3V-300M-16	\$132.00/16 stations	4V-300M-16		\$132.00/16 stations			
3V-300M-B	\$4.84/blank plate	4V-300M-B		\$4.84/blank plate			
3V-400M-2	\$27.50/2 stations	Integrated Base for Mounting 3V400 or 3A400 series Solenoid Valves	4V-400M-2	\$27.50/2 stations	Integrated Base for Mounting 4V400 or 4A400 series Solenoid Valves		
3V-400M-4	\$55.00/4 stations		4V-400M-4	\$55.00/4 stations			
3V-400M-6	\$82.50/6 stations		4V-400M-6	\$82.50/6 stations			
3V-400M-8	\$110.00/8 stations		4V-400M-8	\$110.00/8 stations			
3V-400M-16	\$220.00/16 stations		4V-400M-16	\$220.00/16 stations			
3V-400M-B	\$4.84/blank plate		4V-400M-B	\$4.84/blank plate			

\* Includes mounting hardware and seals

## Specifications

Valve Type	3V & 4V 100-400 Series Valves	2V1, 3V1, 2V025-035 2P025-035 Series	3A & 4A 100-400 Series Valves
Port & Mounting	Body Ported, Manifold Mounted	Body Ported, Stacking or Manifold Mounted	Body Ported, Manifold Mounted
Action & Motion	Internal Pilot, Spool Design	Direct Acting	Air Pilot, Spool Design
Operating Pressure	21 to 115 PSI	Vacuum to 115 PSI	0 to 115 PSI
Coil Insulation & Protection Class	F Class, IP65 (CE Certification)	F Class, IP65 (CE Certification)	N/A
Coil Duty Cycle	100% ED	100% ED	100% ED
Manual Override	Non-Locking: 100 series,	Non-Locking	N/A
Electrical Connection	D = DIN (with LED indicator, conduit terminal)		N/A
Working Medium	40 micron filtered air or inert gas	40 micron filtered air, inert gas & liquid	40 micron filtered air or inert gas
Maximum Pressure	180 PSI		
Operating Temperature	14 to 140 Deg. F (-10 to 60 Deg. C)		
Body Material	Aluminum (Engineered Plastic for 2P Series)		
Seal Material	NBR (Buna N)		
Lubrication	Not Required		
Service	Air		

# Air Solenoid Valve Dimensions

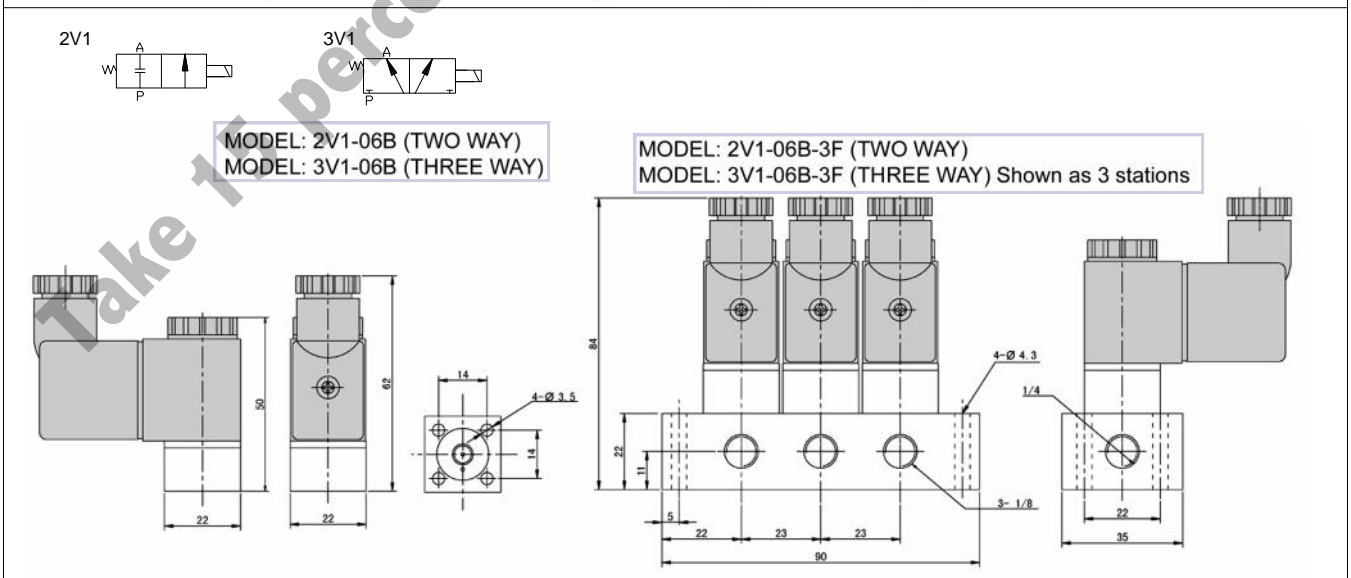
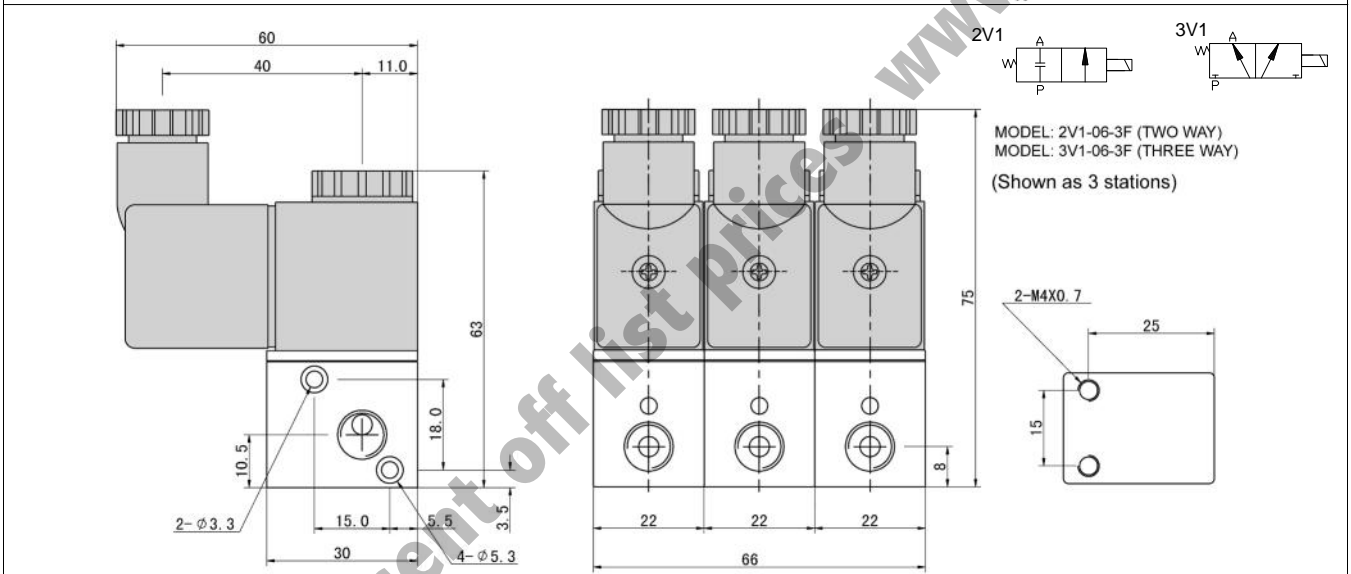
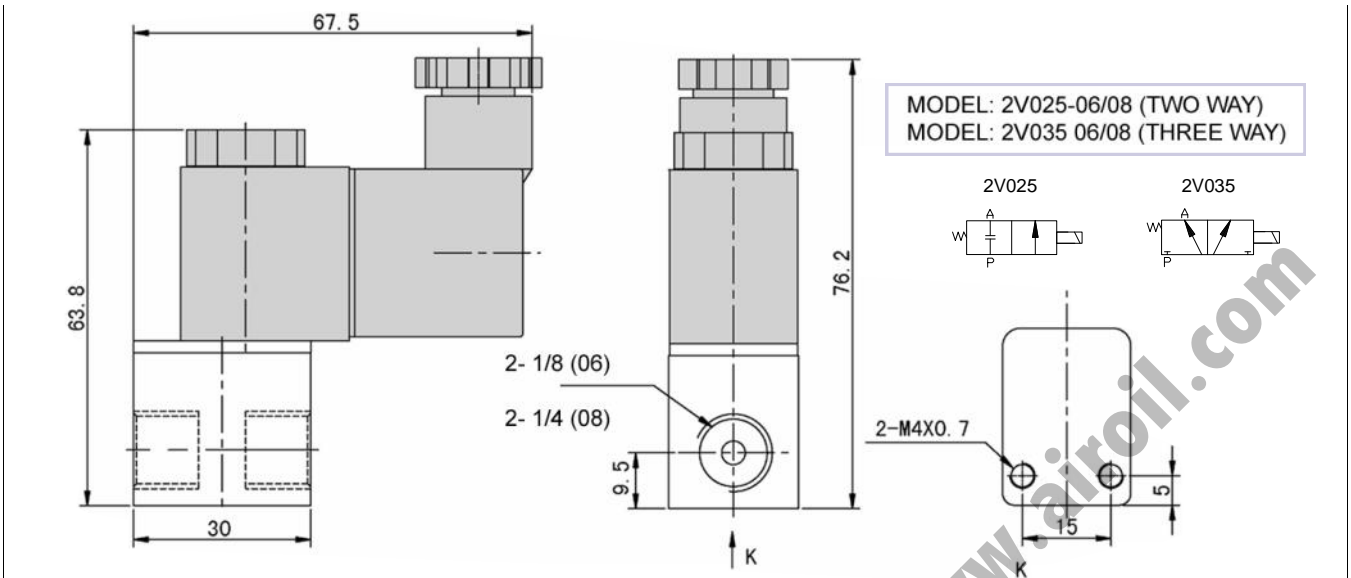

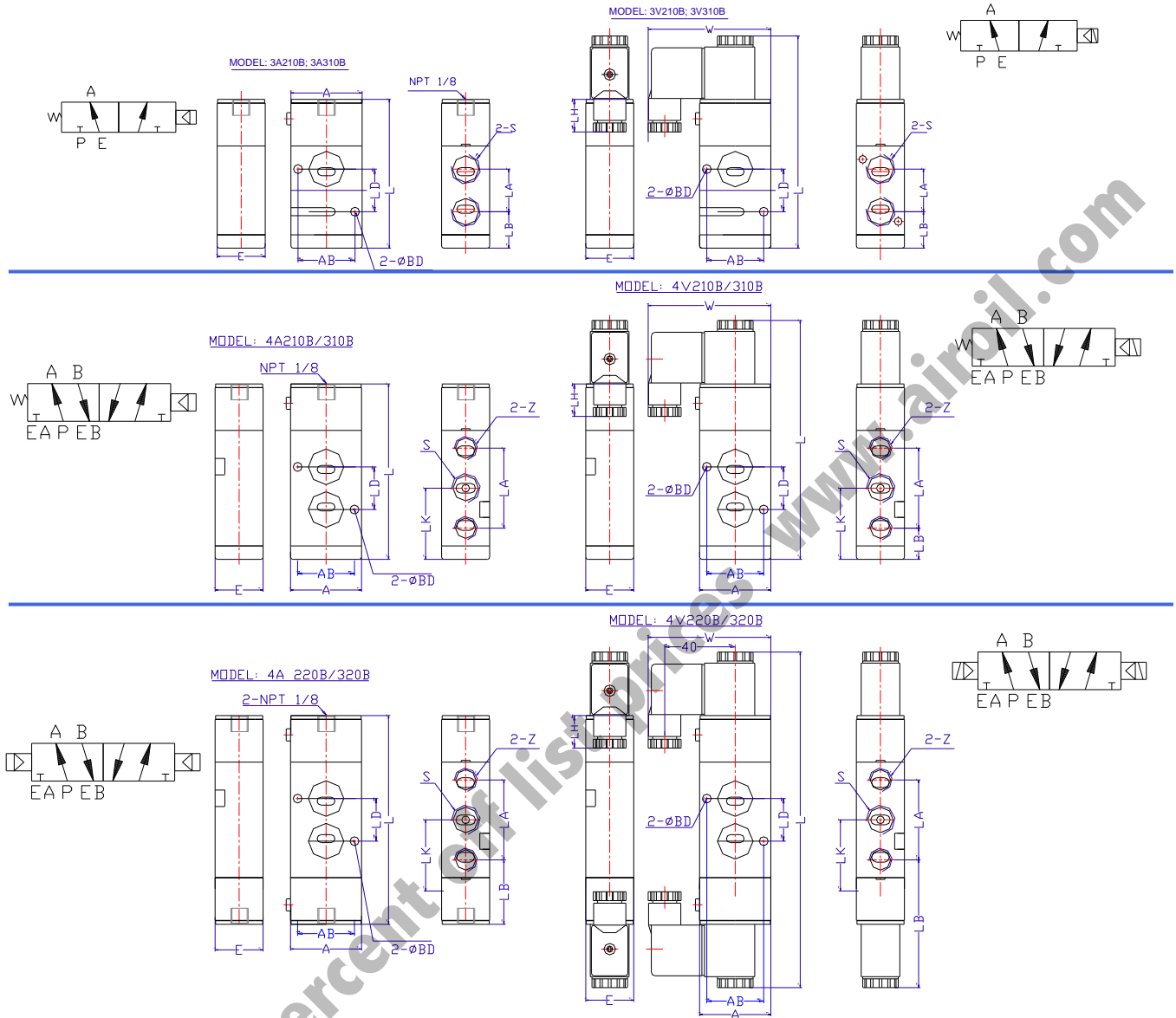

Model	A	E	L	S	W	Z	AB	BD	LA	LB	LD	LH	LK
3A210-1/4B	35	22	77.7	1/4	66.5		29	4.3	18	21			
3A310-1/4B	40	27	80.5	3/8	69		32	5.5	24	20.5			
3A310-3/8B	40	27	80.5	3/8	69		32	5.5	24	20.5			
3V210-1/4B	35	22	111.5	1/4	66.5		29	4.3	18	21		18	
3V310-1/4B	40	27	119.4	1/4	69		32	5.5	24	20.5		18	
3V310-3/8B	40	27	119.4	3/8	69		32	5.5	24	20.5		18	
4A210-1/4B	35	22	77.7	1/4	66.5	1/8	29	4.3	36	13.5	23		31.7
4A310-1/4B	40	27	95.5	1/4	69	1/4	32	5.5	45	17.5	24		40
4A310-3/8B	40	27	95.5	3/8	69	1/4	32	5.5	45	17.5	24		40
4V210-1/4B	35	22	116.5	1/4	66.5	1/8	29	4.3	36	13.5	23	18	32.5
4V310-1/4B	40	27	134.5	1/4	69	1/4	32	5.5	45	17.5	24	18	40
4V310-3/8B	40	27	134.5	3/8	69	1/4	32	5.5	45	17.5	24	18	40
4A220-1/4B	35	22	92	1/4	66.5	1/8	29	4.3	36	28	23		46
4A320-1/4B	40	27	111	1/4	69	1/4	32	5.5	45	33	24		55.5
4A320-3/8B	40	27	111	3/8	69	1/4	32	5.5	45	33	24		55.5
4V220-1/4B	35	22	169.8	1/4	66.5	1/8	29	4.3	36	66.9	23	18	84.9
4V320-1/4B	40	27	188.8	1/4	69	1/4	32	5.5	45	71.9	24	18	94.4
4V320-3/8B	40	27	188.8	3/8	69	1/4	32	5.5	45	71.9	24	18	94.4

# Air Solenoid & Air Pilot Valves Dimensions

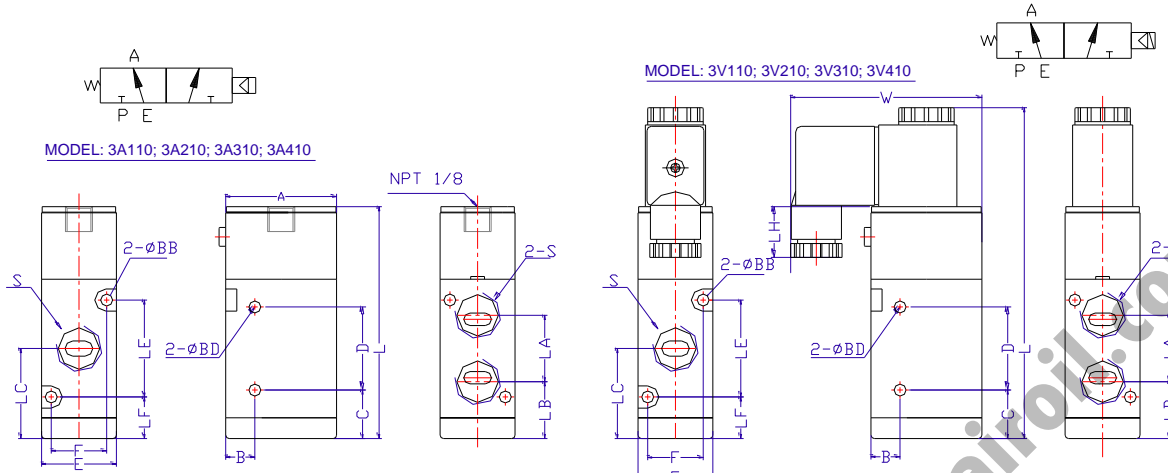

MODEL	A	B	D	E	F	L	S	W	BB	BD	LA	LB	LC	LE	LF	LH
3A110-1/8	27	7.7	21	18.0	13	56.5	1/8	53.5	3.3	3.3	16	14.0	23	19	12.5	
3A210-1/4	35	8.0	25	22.0	17	77.7	1/4	66.5	3.3	4.3	18	21.0	31	33	12.5	
3A310-3/8	40	10.5	30	27.0	20	80.5	3/8	69	4.3	4.3	24	20.5	32.5	35	15	
3A410-1/2	50	13.5	51	34.0	27	96.5	1/2	73.9	4.3	5.5	36	25.5	41.5	44	15.5	
3V110-1/8	27	7.7	21	18.0	13	85.8	1/8	53.5	3.3	3.3	16	14.0	23	19	12.5	10
3V210-1/4	35	8.0	25	22.0	17	111.5	1/4	66.5	3.3	4.3	18	21.0	31	33	12.5	18
3V310-3/8	40	10.5	30	27.0	20	119.4	3/8	69	4.3	4.3	24	20.5	32.5	35	15	18
3V410-1/2	50	13.5	51	34.0	27	137.0	1/2	73.5	4.3	5.5	36	25.5	41.5	44	15.5	18

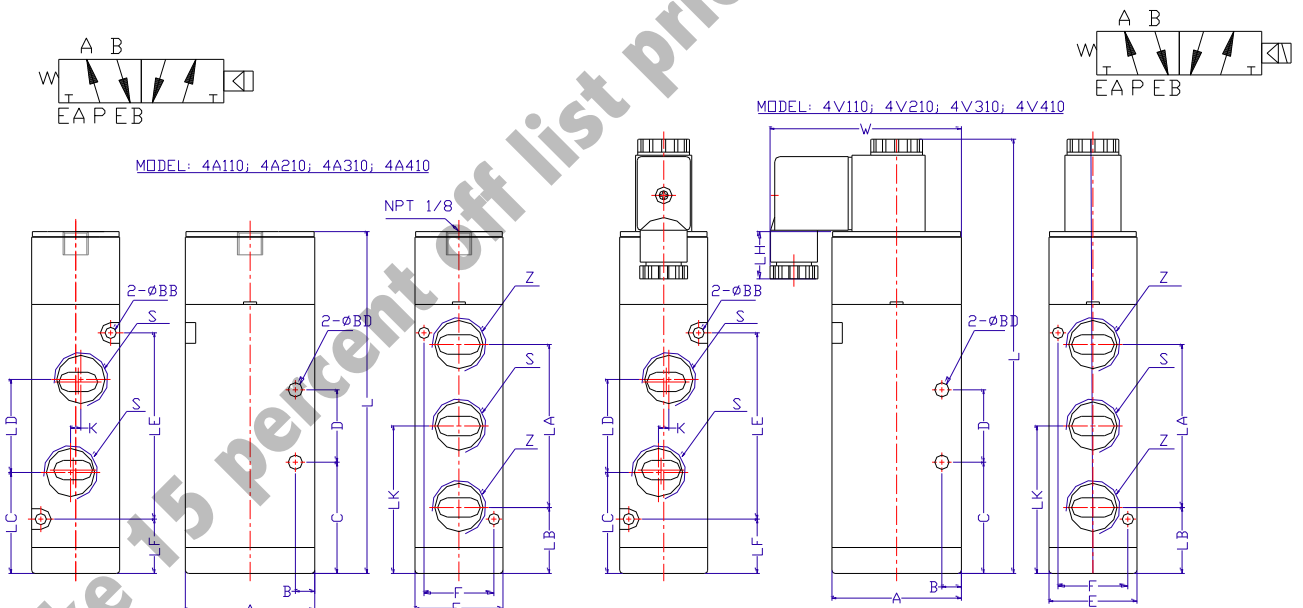

Model	A	B	C	D	E	F	K	L	S	W	Z	BB	BD	LA	LB	LC	LD	LE	LF	LH	LK
4A110-1/8	27	4.0	21.0	14	18	13	3	68.7	1/8	53.5	1/8	3.3	3.3	28	14.2	20.2	16	30	13.0		28.2
4A210-1/4	35	7.0	21.5	20	22	17	3	77.7	1/4	66.5	1/8	3.3	4.3	36	13.5	21.0	21	38	12.5		31.7
4A310-3/8	40	6.5	28.0	24	27	20	4	95.5	3/8	69	1/4	4.3	4.3	45	17.5	28.0	24	50	15.0		40.0
4A410-1/2	50	7.5	43.0	28	34	27	4	128	1/2	73.5	1/2	4.3	5.5	63	25.5	39.0	36	72	21.0		57.0
4V110-1/8	27	4.0	21.0	14	18	13	3	98	1/8	53.5	1/8	3.3	3.3	28	14.0	20.0	16	30	13.0	10	28.0
4V210-1/4	35	7.0	21.5	20	22	17	3	116.5	1/4	66.5	1/8	3.3	4.3	36	13.5	21.0	21	38	12.5	18	32.5
4V310-3/8	40	6.5	28.0	24	27	20	4	134.5	3/8	69	1/4	4.3	4.3	45	17.5	28.0	24	50	15.0	18	40.0
4V410-1/2	50	7.5	43.0	28	34	27	4	167.9	1/2	73.5	1/2	4.3	5.5	63	25.5	39.0	36	72	21.0	18	57.0



# Air Solenoid & Air Pilot Valves | Manifolds Dimensions

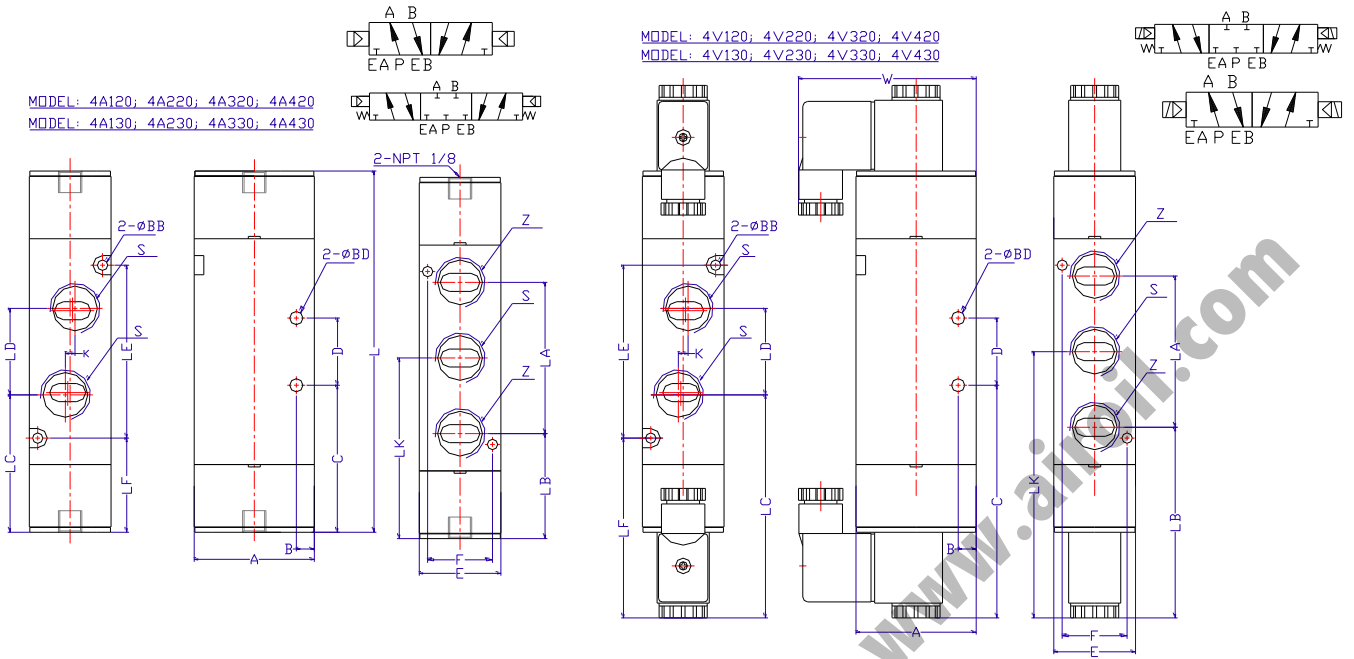

Model	A	B	C	D	E	F	K	L	S	W	Z	BB	BD	LA	LB	LC	LD	LE	LF	LH	LK
4A120-1/8	27	4.0	33.5	14	18	13	3	81	1/8	53.5	1/8	3.3	3.3	28	26.5	32.5	16	30	25.5		40.5
4A220-1/4	35	7.0	36.0	20	22	17	3	92	1/4	66.5	1/8	3.3	4.3	36	28.0	37.0	21	38	27.0		46.0
4A320-3/8	40	6.5	43.5	24	27	20	4	111	3/8	69	1/4	4.3	4.3	45	33.0	43.5	24	50	30.5		55.5
4A420-1/2	50	7.5	51.0	28	34	27	4	128	1/2	73.5	1/2	4.3	5.5	63	39.5	71.0	36	72	35.0		71.0
4V120-1/8	27	4.0	62.8	14	18	13	3	139.5	1/8	53.5	1/8	3.3	3.3	28	56.0	52.0	16	30	54.8	10	69.8
4V220-1/4	35	7.0	74.9	20	22	17	3	169.8	1/4	66.5	1/8	3.3	4.3	36	66.9	74.4	21	38	65.9	18	84.9
4V320-3/8	40	6.5	82.4	24	27	20	4	188.8	3/8	69	1/4	4.3	4.3	45	71.9	82.4	24	50	69.4	18	94.4
4V420-1/2	50	7.5	96.9	28	34	27	4	217.5	1/2	73.5	1/2	4.3	5.5	63	79.4	92.9	36	72	74.9	18	110.9
4A130-1/8	27	4.0	33.5	14	18	13	3	96	1/8	53.5	1/8	3.3	3.3	28	26.5	32.5	16	30	25.5		40.5
4A230-1/4	35	7.0	36.0	20	22	17	3	110	1/4	66.5	1/8	3.3	4.3	36	28.0	37.0	21	38	27.0		46.0
4A330-3/8	40	6.5	43.5	24	27	20	4	130	3/8	69	1/4	4.3	4.3	45	33.0	43.5	24	50	30.5		55.5
4A430-1/2	50	7.5	51.0	28	34	27	4	165	1/2	73.5	1/2	4.3	5.5	63	39.5	71.0	36	72	35.0		71.0
4V130-1/8	27	4.0	62.8	14	18	13	3	154.8	1/8	53.5	1/8	3.3	3.3	28	56.0	52.0	16	30	54.8	10	69.8
4V230-1/4	35	7.0	74.9	20	22	17	3	188.8	1/4	66.5	1/8	3.3	4.3	36	66.9	74.4	21	38	65.9	18	84.9
4V330-3/8	40	6.5	82.4	24	27	20	4	207.8	3/8	69	1/4	4.3	4.3	45	71.9	82.4	24	50	69.4	18	94.4
4V430-1/2	50	7.5	96.9	28	34	27	4	242.8	1/2	73.5	1/2	4.3	5.5	63	79.4	92.9	36	72	74.9	18	110.9

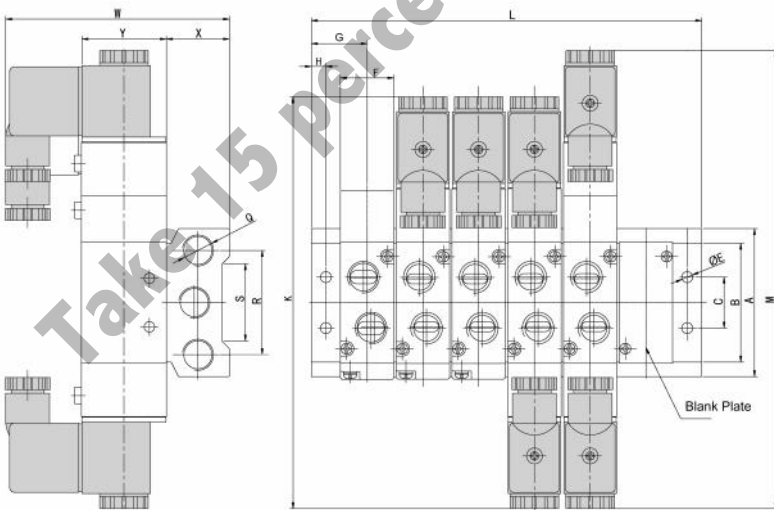

## 4V100-400M Manifold Dimensions

Model	A	B	C	E	F	G	H	K	L
100M	58	44	20	4.2	18.3	19	5	140	(N-1)*19+38
200M	61	51	21	4.3	22.4	23	6	170	(N-1)*23+46
300M	75	65	26	4.5	27.3	27	6	189	(N-1)*28+54
400M	104	95	32	5.5	34.3	31.5	7	222	(N-1)*35+63

Model	M	Q	R	S	T	W	X	Y
100M	155	1/4	40	30	M3x.5	78.5	25	27
200M	189	1/4	43	32	M3x.5	92.5	26	35
300M	208	3/8	53	48	M4x.7	99	30	40
400M	243	1/2	68	67	M4x.7	112	38	50

# Manual & Actuated Process Valves

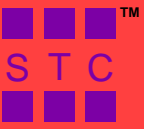

Fine Quality

Precision Engineered

Advanced Design

Excellent Prices

STC™



## Contents

STC Process Valve Numbering System.....	D2-3
STC Process Valve List Price.....	D4-7
STC Solenoid Valve Specifications.....	D7
STC Valve Technical Data.....	D8-12

## STC Process Solenoid Valve Numbering System

Ordering Part No. =  
eg. 2W025-1/4-1

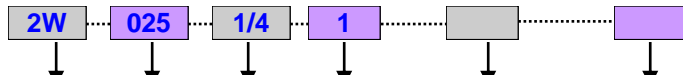

ACTION	NC/NO	Body Material	Model	Orifice Size 10X (mm)	Port Size NPT	Voltage Options	Coil Power	Seal Options	Cv	Features						
2 Way Direct Acting Zero Differential	NC	Stainless	2H	012	1/8	1 = 12 VDC 2 = 24 VDC  2A = 24 VAC 3 = 110 VAC 4 = 220VAC (50/60Hz) E = Explosion Proof	Power Options:  Blank=High Power (100% Rated Pressure)  M=High Power (80% Rated Pressure)  L= Low Power (40% Rated Pressure flow)	Blank: NBR  Options: E=EPDM, V=Viton P=PTFE	0.05	Operating Temp: -5 to 80 °C Operating Pressure: 2P/2V: Vacuum to 115 PSI 2S/2W: Vacuum to 150 PSI  Coil: F Class, IP65, 100% ED Seals: NBR, (Viton Option) Service: Air, Gas, Liquid						
		Plastic	2P	025	1/8				0.23							
		Aluminum	2V	025	1/4				0.23							
		Stainless	2S	025	1/4				0.23							
	NO	Stainless	2SO	025	1/4				0.6							
		Brass	2WO	040	3/8				0.23							
3 Way Direct Acting Zero Differential	NC/NO	Plastic	3P	010	1/8	Wetted Parts: 2P: Plastic & Stainless Steel 2V: Aluminum & Stainless Steel 2S: Stainless Steel 2W: Brass & Stainless Steel			0.05							
		Aluminum	3V	015	1/4				0.1							
		Stainless	3S	015	1/4				0.1							
	NO	Brass	3W	015	1/4				0.1							
		Stainless Steel	2S	160	3/8				1 = 12 VDC 2 = 24 VDC  2A = 24 VAC 3 = 110 VAC 4 = 220VAC (50/60Hz)	Power Options:  Blank=High Power (100% Rated Pressure)  M=High Power (80% Rated Pressure)  L= Low Power (40% Rated Pressure flow)	Blank: NBR  Options: V=Viton	4.8				
		Stainless Steel		160	1/2							4.8				
Brass	2W	200		3/4	7.6											
2 Way Direct Lift Diaphragm Zero Differential	NC	Stainless Steel	2S	250	1	2A = 24 VAC 3 = 110 VAC 4 = 220VAC (50/60Hz)	Power Options:  Blank=High Power (100% Rated Pressure)  M=High Power (80% Rated Pressure)  L= Low Power (40% Rated Pressure flow)	Blank: NBR  Options: V=Viton				12	Operating Temp: -5 to 80 °C Operating Pressure: Vacuum to 150 PSI Coil: F Class, IP65, 100% ED Seals: NBR, (Viton Option) Service: Air, Gas, Liquid  Wetted Parts: 2S/2SO: Stainless Steel 2W/2WO: Brass & Stainless Steel			
				350	1 1/4							24				
				400	1 1/2							29				
				500	2				48							
				NO	Stainless Steel				2SO	160	3/8	4.8				
										160	1/2	4.8				
	200	3/4	7.6													
	250	1	12													
	Brass	2WO	350							1 1/4	24					
			400							1 1/2	29					
	2 Way Direct Lift Piston Zero Differential	NC	Brass	2L	170				3/8	1 = 12 VDC 2 = 24 VDC  2A = 24 VAC 3 = 110 VAC 4 = 220VAC (50/60Hz)	Power Options:  Blank=High Power (100% Rated Pressure)  M=High Power (80% Rated Pressure)  L= Low Power (40% Rated Pressure flow)	Blank: PTFE Standard		4.8	Operating Temp: -5 to 150 °C Operating Pressure: 0 to 215PSI Coil: F Class, IP65, 100% ED Seals: NBR, (Viton Option) Service: Air, Gas, Liquid Wetted Parts: 2L: Brass & Stainless Steel 2LS: Stainless Steel	
					170				1/2					4.8		
170					3/4	4.8										
200					1	12										
Stainless Steel					2LS	300	1 1/4	20								
						300	1 1/2	20								
2 Way Pilot Diaphragm 5 PSI Differential	NC	Brass	2V	130	3/8	1 = 12 VDC 2 = 24 VDC  2A = 24 VAC 3 = 110 VAC 4 = 220VAC (50/60Hz)	Power Options:  Blank=High Power (100% Rated Pressure)  M=High Power (80% Rated Pressure)  L= Low Power (40% Rated Pressure flow)	Blank: NBR Standard	6.2				Operating Temp: -5 to 80 °C Operating Pressure: 4 to 115 PSI Coil: F Class, IP65, 100% ED Seal: NBR Service: Air, Gas, Liquid Wetted Parts: Brass			
				130	1/2				23							
				250	3/4				23							
				250	1				1.2							
				Teflon	2T				060					1/4		1.2
									060					3/8		1.2
	NO	Brass	2H	120	3/8				4.5							
				2HO	150				1/2	4.5						
	2 Way Pilot Piston 7 PSI Differential	NC	Stainless Steel	2MS	120				3/8	1 = 12 VDC 2 = 24 VDC  2A = 24 VAC 3 = 110 VAC 4 = 220VAC (50/60Hz)	Power Options:  Blank=High Power (100% Rated Pressure)  M=High Power (80% Rated Pressure)  L= Low Power (40% Rated Pressure flow)	Blank: PTFE Standard		4.5	Operating Temp: -20 to 180°C Operating Pressure: 7 to 230 PSI Coil: F Class, IP65, 100% ED Seal: PTFE Service: Air, Gas, Liquid, Steam Wetted Parts: stainless Steel	
					150				1/2					4.5		
					200				3/4					9.3		
					250				1					12		
320					1 1/4	24										
NO		2MSO		400	1 1/2	29										
				500	2	48										

## STC Manual Valve Numbering System

Ordering Part No. =  
(eg. V1-1/4)

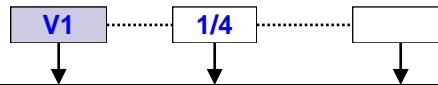

Manual Ball Valves	Model	Port Size (NPT)	Options
Reduced port 316 SS ball valve (1 Piece)	V1	1/4	
Full port 316 SS ball valve (2 Piece)	V2	3/8	
Full port 316 SS ball valve (3 Piece)	V3	1/2	
Full port 316 SS ball valve (3 Piece, Tri-Clamp)	V3C	3/4	
Full port brass ball valve (2 Piece)	T101L	1	
Reduced port chrome plated brass ball valve (FXF port)	T400	1 1/4	
Reduced port chrome plated brass ball valve (FXM port)	T400FM	1 1/2	
316 SS Needle valve	VNO1	2	

## STC Air Actuated Valve Numbering System

Ordering Part No. =  
(eg. KS 1/2)

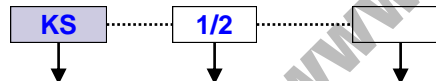

		AIR ACTUATED VALVE	Model	Port Size (NPT)	Options
	<b>Ball Valve</b> 316 Stainless Steel	Single Acting (Spring Return)	KS	1/2"	
		Double Acting (Air Return)	KD	3/4"	
	<b>Angle Valve</b> 316 Stainless Steel	Single Acting (Spring Return)	2KS	1"	
		Double Acting (Air Return)	2KD	1 1/4"	
	<b>Plunger Valve</b> Brass	Single Acting (Spring Return)	2QS	1 1/2"	
		Double Acting (Air Return)	2QD	2"	

## STC Coil Numbering System

Ordering Part No. =  
(eg. 2W200C-1)

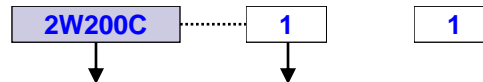

Coils	Model	Voltage	Wattage, W
Coil for 2P & 2V Series Valves	200C	1 = 12 VDC 2 = 24 VDC	3, 4.8, 6.5
Coil for 2W & 2S 025 TO 250 series valves	2W200C	2A = 24 VAC 3 = 110 VAC 4 = 220VAC (50-60Hz)	14, 20, 25
Coil for 2WO & 2SO 160 TO 500 series valves	2WOC		20-40
Coil for 2L, 2W & 2S 350 TO 500 series valves	2W300C		25-65

# Process Solenoid Valve List Price

To Order, Please Specify: 1. <b>Model No.</b> , 2. <b>Voltage</b>									
	Valve Type	Part No.	List Price	Port Size (NPT)	Voltage Options	Power (W)	Cv	Features	
	2 Way, NC Direct Acting Plastic Body	2P025-1/8	\$18.81	1/8	1 = 12 VDC 2 = 24VDC	3-6.5	0.23	2 Way, Direct Acting, Normally Closed Operating Temp: -5 to 80 °C Operating Pressure: Vacuum to 115 PSI Coil: F Class, IP65, 100% ED Service: Air, Gas, Liquid Seals: NBR, (Viton Option) Body Material: 2P Series: Engineered Plastic/Stainless Steel 2V Series: Anodized Aluminum Body	
		2P025-1/4	\$18.81	1/4			0.23		
	2 Way, NC Direct Acting Aluminum Body	2V025-1/8	\$18.81	1/8	2A=24VAC 3 = 110VAC 4 = 220VAC (50/60Hz)	3-6.5	0.23		
		2V025-1/4	\$18.81	1/4			0.23		
	2 Way, NC Direct Acting Brass Body	2W025-1/4	\$27.50	1/4	1 = 12 VDC 2 = 24VDC	14-20	0.23	2 Way, Direct Acting, Normally Closed Operating Temp: -5 to 80 °C Operating Pressure: Vacuum to 150 PSI Coil: H Class, IP65, 100% ED Service: Air, Gas, Liquid Seals: NBR, (Viton Option) Body Material: 2S Series: 304 Stainless Steel Body 2W Series: Brass	
		2W040-3/8	\$34.16	3/8			0.60		
	2 Way, NC Direct Acting Stainless Steel Body	2S025-1/4	\$30.69	1/4	2A=24VAC 3 = 110VAC 4 = 220VAC (50/60Hz)	14-20	0.23		
		2S040-3/8	\$42.57	3/8			0.6		
	1000 PSI, 2 Way, NC Direct Acting	2H012	\$56.25	1/8	1 = 12 VDC 2 = 24VDC	15	0.05	2 Way, Direct Acting, Normally Closed Operating Temp: 0 to 85 °C Operating Pressure: Vacuum to 300, 500, 1000 PSI Coil: H Class, IP65, 100% ED Service: Air, Gas, Liquid Seals: Teflon Body Material: Stainless Steel	
	500 PSI, 2 Way, NC Direct Acting	2H024	\$56.25	1/8			2A=24VAC 3 = 110VAC 4 = 220VAC (50/60Hz)		0.09
	300 PSI, 2 Way, NC Direct Acting	2H032	\$56.25	1/8					0.23
	2 Way, NO Direct Acting Stainless Steel	2SO025-1/4	\$54.45	1/4	1 = 12 VDC 2 = 24VDC	30	0.23		2 Way, Direct Acting, Normally Open Operating Temp: -5 to 80 °C Operating Pressure: Vacuum to 150 PSI Coil: H Class, IP65, 100% ED Service: Air, Gas, Liquid Seals: NBR, (Viton Option) Body Material: 2S Series: 304 Stainless Steel Body 2W Series: Brass
		2SO040-3/8	\$63.80	3/8			0.6		
	2 Way, NO Direct Acting Brass	2WO025-1/4	\$48.80	1/4	2A=24VAC 3 = 110VAC 4 = 220VAC (50/60Hz)	0.23			
		2WO040-3/8	\$56.80	3/8		0.6			
	3 Way, NC Direct Acting Plastic	3P010-1/8	\$19.80	1/8	1 = 12 VDC 2 = 24VDC	3-6.5	0.05	3 Way, Direct Acting Operating Temp: -5 to 80 °C Pressure: Vacuum to 115 PSI Coil: F Class, IP65, 100% ED Service: Air, Gas, Liquid Seals: NBR, (Option: Viton)	
		3P010-1/4	\$19.80	1/4			0.05		
	3 Way, NC Direct Acting Aluminum	3V010-1/8	\$19.80	1/8	2A=24VAC 3 = 110VAC 4 = 220VAC (50/60Hz)	3-6.5	0.05		
		3V010-1/4	\$19.80	1/4			0.05		
	3 Way, NC Direct Acting Stainless Steel	3S015-1/4	\$47.50	1/4	2A=24VAC 3 = 110VAC 4 = 220VAC (50/60Hz)	14-20	0.1	3 Way, Direct Acting Operating Temp: -5 to 80 °C Pressure: Vacuum to 150 PSI Coil: F Class, IP65, 100% ED Service: Air, Gas, Liquid Seals: NBR, (Option: Viton Seal high temperature -40-180 °C)	
		3W015-1/4	\$42.50	1/4			0.1		
	2 Way, NC Direct Lift Diaphragm Brass Zero Differential	2W160-3/8	\$54.45	3/8	1 = 12 VDC 2 = 24VDC	14-20	4.8		Normally Closed, 2 Way Direct Lift Diaphragm Operating Temp: -5 to 80 °C Operating Pressure: Vacuum to 150 PSI Coil: F Class, IP65, 100% ED Service: Air, Gas, Liquid Seals: NBR, (Viton High Temp. Option) Body Material: Brass
		2W160-1/2	\$54.45	1/2			4.8		
		2W200-3/4	\$62.87	3/4			7.6		
		2W250-1	\$76.73	1		12			
		2W350-1 1/4	\$169.29	1 1/4		24			
		2W400-1 1/2	\$188.10	1 1/2		29			
	2 Way, NC Direct Lift Diaphragm Stainless Steel Zero Differential	2W500-2	\$273.24	2	2A=24VAC 3 = 110VAC 4 = 220VAC (50/60Hz)	35	48		
		2S160-3/8	\$103.46	3/8		14-20	4.8	Normally Closed, 2 Way Direct Lift Diaphragm, Operating Temp: -5 to 80 °C Operating Pressure: Vacuum to 150 PSI Coil: F Class, IP65, 100% ED Service: Air, Gas, Liquid Seals: NBR, (Viton High Temp. Option) Body Material: 304 Stainless Steel	
		2S160-1/2	\$103.46	1/2			4.8		
		2S200-3/4	\$117.32	3/4			7.6		
		2S250-1	\$131.18	1		12			
		2S350-1 1/4	\$239.71	1 1/4		24			
2S400-1 1/2	\$255.75	1 1/2	29						
	2 Way, NC Direct Lift Diaphragm Stainless Steel Zero Differential	2S500-2	\$399.56	2	2A=24VAC 3 = 110VAC 4 = 220VAC (50/60Hz)	35	48		



# Process Solenoid Valve List Price



To Order, Please Specify: 1) Model No., 2) Voltage								
		Part No.	List Price	Port Size	Voltage	Power	Cv	Features
	2 Way, NO Direct Lift Diaphragm Zero Differential Brass	2WO 160-3/8	\$91.58	3/8	Voltage Options: 1 = 12 VDC 2 = 24VDC	30	4.8	<b>Normally Open</b> 2 Way, Direct Lift Diaphragm Temperature: -5 to 80 °C Pressure: Vacuum to 150 PSI Coil: F Class, IP65, 100% ED Service: Air, Liquid Seals: NBR (Option: Viton, EPDM)  Body Material: 2S Series: 304 Stainless Steel 2W Series: Brass
		2WO 160-1/2	\$91.58	1/2			4.8	
		2WO 200-3/4	\$99.88	3/4			7.6	
		2WO 250-1	\$116.55	1			12	
		2WO 350-1 1/4	\$205.00	1 1/4			24	
		2WO 400-1 1/2	\$235.00	1 1/2			29	
		2WO 500-2	\$315.00	2			48	
	2 Way, NO Direct Lift Diaphragm Zero Differential Stainless Steel	2SO 160-3/8	\$119.00	3/8	2A=24VAC 3 = 110VAC 4 = 220VAC (50/60Hz)	30	4.8	
		2SO 160-1/2	\$129.84	1/2			4.8	
		2SO 200-3/4	\$151.51	3/8			7.6	
		2SO 250-1	\$238.00	1			12	
		2SO 350-1 1/4		1 1/4			24	
		2SO 400-1 1/2	\$330.00	1 1/2			29	
		2SO 500-2	\$450.00	2			48	
	2 Way, NC Direct Lift Piston Zero Differential Brass	2L170-3/8	\$87.95	3/8	Voltage Options: 1 = 12 VDC 2 = 24VDC  2A=24VAC 3 = 110VAC 4 = 220VAC (50/60Hz)	35	4.8	<b>Normally Closed, 2 Way, Pilot Lift Piston</b> Brass Body, Seals: PTFE Operating Temp: -5 to 150 °C Operating Pressure: 3 to 215 PSI Coil: F Class, IP65, 100% ED Service: Air, Gas, Liquid, Steam Installation: Vertical Coil Position , Horizontal Flow
		2L170-1/2	\$103.46	1/2			4.8	
		2L170-3/4	\$117.32	3/4			4.8	
		2L200-1	\$131.18	1			12	
		2L300-1 1/4	\$185.52	1 1/4			20	
		2L300-1 1/2	\$216.32	1 1/2			20	
		2L500-2	\$325.22	2			48	
	2 Way, NC Direct Lift Piston Zero Differential Stainless Steel	2LS120 - 3/8	\$128.00	3/8	Voltage Options: 1 = 12 VDC 2 = 24VDC  2A=24VAC 3 = 110VAC 4 = 220VAC (50/60Hz)	15W 22VA	4.5	Normally Closed, 2 Way, Direct Lift Piston Operation Operating Pressure: 0 to 150 PSI Fluid Temperature: -20°C to 180°C Seal: PTFE Compatible Fluid: Steam, Air, Inert Gases, Water, Liquid, etc.
		2LS150 - 1/2	\$128.00	1/2			4.5	
		2LS200 - 3/4	\$168.00	3/4			9.3	
		2LS250 - 1	\$198.00	1			12	
		2LS320 - 1 1/4		1 1/4			24	
		2LS400 - 1 1/2		1 1/2			29	
		2LS500 - 2		2			48	
	2 Way, NC Pilot Piston Stainless Steel	2MS120 - 3/8	\$128.00	3/8	Voltage Options: 1 = 12 VDC 2 = 24VDC  2A=24VAC 3 = 110VAC 4 = 220VAC (50/60Hz)	15W 22VA	4.5	Normally Closed, 2 Way, Pilot Piston Operation Operating Pressure: 7 to 230 PSI Fluid Temperature: -20°C to 180°C Seal: PTFE Compatible Fluid: Steam, Air, Inert Gases, Water, Liquid, etc.
		2MS150 - 1/2	\$128.00	1/2			4.5	
		2MS200 - 3/4	\$168.00	3/4			9.3	
		2MS250 - 1	\$198.00	1			12	
		2MS320 - 1 1/4		1 1/4			24	
		2MS400 - 1 1/2		1 1/2			29	
		2MS500 - 2		2			48	
	2 Way, NO Pilot Piston Stainless Steel	2MSO120 - 3/8	\$148.00	3/8	Voltage Options: 1 = 12 VDC 2 = 24VDC  2A=24VAC 3 = 110VAC 4 = 220VAC (50/60Hz)	15W 22VA	4.5	Normally Open, 2 Way, Pilot Piston Operation Operating Pressure: 7 to 230 PSI Fluid Temperature: -20°C to 180°C Seal: PTFE Ambient Temperature: -20 to 55°C Compatible Fluid: Steam, Air, Inert Gases, Water, Liquid, etc.
		2MSO150 - 1/2	\$148.00	1/2			4.5	
		2MSO200 - 3/4	\$188.00	3/4			9.3	
		2MSO250 - 1	\$218.00	1			12	
		2MSO320 - 1 1/4		1 1/4			24	
		2MSO400 - 1 1/2		1 1/2			29	
		2MSO500 - 2		2			48	
	2 Way, NC Pilot Diaphragm Brass	2V130-3/8	\$58.80	3/8	Voltage Options: 1 = 12 VDC 2 = 24VDC  2A=24VAC 3 = 110VAC 4 = 220VAC (50/60Hz)	3 to 6.5 W	4.8	<b>Normally Closed, 2 Way, Pilot Operated Diaphragm</b> Brass Body, Seals: NBR Operating Temp -5 to 80°C Operating Pressure: 4 to 115 PSI Coil: F Class, IP65, 100% ED Service: Air, Gas, Water, Liquid
		2V130-1/2	\$58.80	1/2			4.8	
		2V130-3/4	\$113.40	3/4			8	
		2V130-1	\$113.40	1			12	
	Coil Options	200C-U	\$6.50	UL				
200-E		\$85.80	Explosion Proof					
	2 Way, NC Pilot Diaphragm Aluminum	2D200-3/4		3/4	Voltage Options: 1 = 12 VDC 2 = 24VDC 2A=24VAC 3 = 110VAC 4 = 220VAC (50/60Hz)	17	7.6	<b>Normally Closed, 2 Way</b> Seals: NBR Operating Temp: -10 to 80 °C Operating Pressure: 5 to 115 PSI Coil: F Class, IP65, 100% ED Service: Air, Material: Aluminum
		2D250-1		1			12	
		2D400-1 1/4		1 1/4			29	
		2D500-1 1/2		1 1/2			48	



Picture	Valve Type	Part No.	List Price	Port Size (NPT)	Voltage	Power (W)	Cv	Features
	2 Way, NC Direct Acting Teflon	2T060 - 1/4	\$165.00	1/4	1 = 12 VDC 2 = 24VDC	30	2.8	Normally Closed, 2 Way. Teflon Valve Fluid Temperature:-20°C to 180°C Seal: PTFE Operating Pressure: 0 to 22 PSI Compatible Fluid: Corrosive fluid & gas, acid, alkali, etc.
		2T060 - 3/8	\$165.00	3/8	2A=24VAC 3 = 110VAC 4 = 220VAC (50/60Hz)		2.8	
		2T060 - 1/2	\$165.00	1/2			2.8	
	2 Way, NC, Pilot Diaphragm 5 to 1000 PSI	2H100	\$174.00	3/8	1 = 12 VDC 2 = 24VDC	9	4.5	Normally Closed, 2 Way. Pilot Diaphragm Operating Pressure: 5 to 1000 PSI Fluid Temperature: -10 to 150°C Seal: Viton Coil: 9W (DC), 17VA (AC) Compatible Fluid: Air, Water, Oil
		2H150	\$174.00	1/2			4.5	
	2 Way, NO, Pilot Diaphragm 5 to 725 PSI	2HO120	\$188.00	3/8	2A=24VAC 3 = 110VAC 4 = 220VAC (50/60Hz)	9	4.5	Normally Open, 2 Way, Pilot Diaphragm Operating Pressure: 5 to 1000 PSI Fluid Temperature: -10 to 150°C Seal: Viton Coil: 9W (DC), 17VA (AC) Compatible Fluid: Air, Water, Oil
		2HO150	\$188.00	1/2			4.5	

Part No.	Price	Voltage Options	Electrical Connection	Power	Applications
2W200C	\$23.10	1 = 12 VDC 2 = 24VDC 2A=24VAC 3 = 110VAC 4 = 220VAC (AC 50/60Hz)	H Class Insulation, IP65 Duty Cycle: 100% ED  D = DIN (with LED indicator) G = Grommet (12" Lead Wire) F Class Insulation, IP65	12 to 20W	For 2S/2W 025 to 250 series valves
2W350C	\$35.75			25-40W	For 2/S2W 350-500 & 2L 170-500 series valves
2WOC	\$29.70			30-40 W	For 2SO/2WO 160-500 series valves
200C	\$7.92			3 to 6.5 W	For 2V & 2P025-035 & 2V1, 3V1 series valves

## STC Manual Valve List Price

	Reduced Port Ball Valves	Full Port Ball Valves	Full Port Ball Valves	Full Port Ball Valves	Full Port Butterfly Valves	Needle Valves
Model	V1	V2	V3	V3C	VBS01	VN01
Material	316 SS	316 SS	316 SS	316 SS	316 SS	316 Stainless Steel
Port	FNPT	FNPT	FNPT	Clamp	Clamp	NPT Female
Size 1/4"	V1-1/4 \$9.53	V2-1/4 \$15.55	V3-1/4 \$22.23			VN01-1/4 \$27.54
3/8"	V1-3/8 \$9.53	V2-3/8 \$15.55	V3-3/8 \$22.23			VN01-3/8 \$28.44
1/2"	V1-1/2 \$10.53	V2-1/2 \$18.98	V3-1/2 \$26.33			VN01-1/2 \$34.00
3/4"	V1-3/4 \$15.32	V2-3/4 \$27.41	V3-3/4 \$33.53			VN01-3/4 \$48.25
1"	V1-1 \$19.77	V2-1 \$41.06	V3-1 \$45.27	V3C-1 \$53.08	VBS01-1 \$67.39	VN01-1 \$64.94
1 1/4"	V1-1 1/4 \$29.07	V2-1 1/4 \$60.67	V3-1 1/4 \$68.70			
1 1/2"	V1-1 1/2 \$35.60	V2-1 1/2 \$86.68	V3-1 1/2 \$85.83	V3C-1 1/2 \$102.96	VBS01- 1 1/2 \$85.32	
2"	V1-2 \$56.98	V2-2 \$105.53	V3-2 \$128.13	V3C-2 \$144.30	VBS01-2 \$107.59	
3"				V3C-3 \$327.17		

	Miniature Ball Valves	Miniature Ball Valves	Full Port	L Port 3 Way Ball Valve	T Port 3 Way Ball Valve
Model	T400	T400FM	T101L	T103L	T103T
Material	Chrome-Plated Brass	Chrome-Plated Brass	Brass	Nickel Plated Brass	Nickel Plated Brass
Port	F NPT	F x M NPT	F NPT	F NPT	F NPT
Size 1/4"	T400-1/4 \$2.15	T400FM-1/4 \$2.15	T101L-1/4 \$2.72		
3/8"	T400-3/8 \$2.48	T400FM-3/8 \$2.48	T101-3/8		
1/2"	T400-1/2 \$2.90	T400FM-1/2 \$2.90	T101L-1/2 \$4.22	T103L-1/2 \$4.22	T103L-1/2 \$4.22
3/4"			T101L-3/4 \$6.33	T103L-3/4 \$6.33	T103L-3/4 \$6.33
1"			T101L-1 \$10.46		
1 1/4"			T101L-1 1/4 \$15.46		
1 1/2"			T101L-1 1/2 \$21.89		
2"			T101L-2 \$36.14		

# Air Actuated Valves | Specifications



ROTARY PNEUMATIC BALL VALVE	Port Size NPT	Air Actuated Single Acting		Air Actuated Double Acting				
		Model	Price	Model	Price			
	2/2 3 Piece Full Port Ball Valve 316 SS	1/2"	KS-1/2	\$230.00	KD-1/2	\$189.24	Fluid Temperature: w/ PTFE seal, -10°C to 180°C VACUUM TO 1000 PSI  Service: Air, Liquid, Steam, Vacuum	
		3/4"	KS-3/4	\$330.00	KD-3/4	\$273.60		
		1"	KS-1	\$431.52	KD-1	\$358.00		
		1 1/4"	KS-1 1/4	\$498.52	KD-1 1/4	\$428.00		
		1 1/2"	KS-1 1/2	\$560.52	KD-1 1/2	\$498.00		
		2"	KS-2	\$681.60	KD-2	\$542.52		
		3"	KS-3	2044.80	KD-3	1627.56		
	2/2 Angle Valve 304 SS	1/2	2KS - 1/2	\$153.95	2KD - 1/2	\$166.80	Fluid Temperature: w/ PTFE seal, -10°C to 180°C VACUUM TO 230 PSI  Service: Air, Liquid, Steam, Vacuum	
		3/4	2KS - 3/4	\$171.05	2KD - 3/4	\$183.90		
		1	2KS - 1	\$210.40	2KD - 1	\$223.20		
		1 1/4	2KS - 1 1/4	\$299.35	2KD - 1 1/4	\$312.15		
		1 1/2	2KS - 1 1/2	\$316.40	2KD - 1 1/2	\$329.30		
		2	2KS - 2	\$436.20	2KD - 2	\$449.00		
	2/2 Plunger Valve Brass	1/2	2QS-1/2	\$123.20	2QD-1/2	\$112.00	4.8	<b>Double Acting Actuator</b> 2 Way, Direct Acting, Brass Body; Seals: NBR, Option: Viton Operating Temp -5 to 80 deg. C Operating Pressure: 100 PSI Air Pilot Pressure: 80-150 PSI Service: Air, Liquid
		3/4	2QS-3/4	\$132.00	2QD-3/4	\$132.00	7.6	
		1	2QS-1	\$162.00	2QD-1	\$162.00	12	
		1 1/2	2QS-1 1/2	\$266.37	2QD-1 1/2	\$242.15	29	
		2	2QS-2	\$332.97	2QD-2	\$302.70	48	

## Solenoid Valve Specifications

Valve Model	2H012-032	2H100-150	2H0100-150		2L	2LS		2MS	2MSO	2P025	2P035
Valve Type	2 Way	2 Way	2 Way		2 Way	2 Way		2 Way	2 Way	2 Way	3 Way
Normally Closed (NC)	NC	NC	NO		NC	NC		NC	NO	NC	NC
Normally Open (NO)	Direct Acting	Pilot Diaphragm	Pilot Diaphragm		Direct Lift Piston	Direct Lift Piston		Pilot Piston	Pilot Piston	Direct Acting	Direct Acting
Operating Pressure (PSI)	0 to 1000	5 to 1000	5 to 725		0 to 210	0 to 150		7 to 230	7 to 230	0 to 115	0 to 150
Operating Temperature (°C)	0 to 85°C	-10 to 150°C	-10 to 150°C		-20 to 180°C	-20 to 180°C		-20 to 180°C	-20 to 180°C	-5 to 80°C	-5 to 80°C
Port Size (NPT)	1/8	3/8 to 1/2	3/8 to 1/2		3/8 to 2	3/8 to 2		3/8 to 2	3/8 to 2	1/8 to 1/4	1/8 to 1/4
Body Materials	Stainless Steel	SS/Brass	SS/Brass		Brass	Stainless Steel		Stainless Steel	Stainless Steel	Engineered Plastic	Engineered Plastic
Seal Materials NBR (Options: EPDM, Viton)	Teflon	Viton	Viton		PTFE	PTFE		PTFE	PTFE	NBR	NBR
Coil Protection Insulation Class	H Class IP65	H Class IP65	H Class IP65		H Class IP65	H Class IP65		H Class IP65	H Class IP65	B Class IP65	B Class IP65
Coil Duty	100% ED	100% ED	100% ED		100% ED	100% ED		100% ED	100% ED	100% ED	100% ED
Coil Power	14W	9 W, 17VA	9 W, 17VA		35W	15 W, 22VA		15 W, 22VA	15 W, 22VA	6.5W	6.5W
Electrical Connections	Conduit	DIN	DIN		DIN	DIN		DIN	DIN	DIN	DIN
Service	Air, Liquid				Air, Liquid, Steam			Air, Liquid, Steam		Air, Liquid, Vacuum	
Valve Model	2S025-040	2S160-500	2SO160-500	2T	2V025	2V130-250	2W025-040	2W160-500	2WO160-500	3S	3W
Valve Type	2 Way	2 Way	2 Way	2 Way	2 Way	2 Way	2 Way	2 Way	2 Way	3 Way	3 Way
Normally Closed (NC)	NC	NC	NO	NC	NC	NC	NC	NC	NO	NC	NC
Normally Open (NO)	Direct Acting	Direct Lift Diaphragm	Direct Lift Diaphragm	Direct Lift Diaphragm	Direct Acting	Pilot Diaphragm	Direct Acting	Direct Acting	Direct Lift Diaphragm	Direct Acting	Direct Acting
Operating Pressure (PSI)	0 to 150	0 to 150	0 to 150	0 to 22	0 to 115	4 to 115	0 to 150	0 to 150	0 to 150	0 to 150	0 to 150
Operating Temperature (°C)	-5 to 80°C	-5 to 80°C	-5 to 80°C	-20 to 80°C	-5 to 80°C	-5 to 80°C	-10 to 80°C	-10 to 80°C	-10 to 80°C	-10 to 80°C	-10 to 80°C
Port Size (NPT)	1/4 to 3/8	3/8 to 2	3/8 to 2	1/4 to 1/2	1/8 to 1/4	3/8 to 1	1/4 to 3/8	3/8 to 2	3/8 to 2	1/8 to 1/4	1/8 to 1/4
Body Materials	Stainless Steel	Stainless Steel	Stainless Steel	Teflon	Aluminum	Brass	Brass	Brass	Brass	Stainless Steel	Brass
Seal Materials: NBR (Options: EPDM, Viton)	NBR	NBR	NBR	Teflon	NBR	NBR	NBR	NBR	NBR	NBR	NBR
Coil Protection Insulation Class	H Class IP65	H Class IP65	H Class IP65	H Class IP65	B Class IP65	B Class IP65	H Class IP65	H Class IP65	H Class IP65	H Class IP65	H Class IP65
Coil Duty	100% ED	100% ED	100% ED	100% ED	100% ED	100% ED	100% ED	100% ED	100% ED	100% ED	100% ED
Coil Power	14-20W	20-35W	30W	20W	6.5W	6.5W	14 to 20W	20-35W	30W	14W	14W
Electrical Connections	DIN	DIN	DIN	DIN	DIN	DIN	DIN	DIN	DIN	DIN	DIN
Service	Air, Liquid, Vacuum			Air, Liquid	Air, Liquid, Vacuum						

# STC Solenoid Valve Dimensions

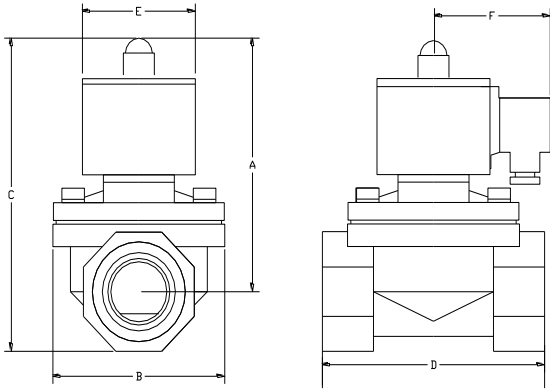
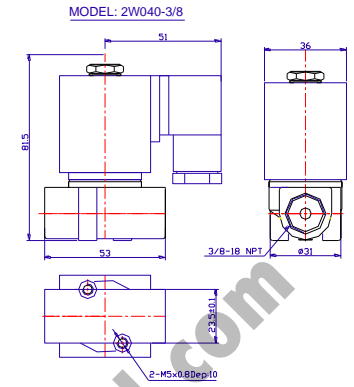
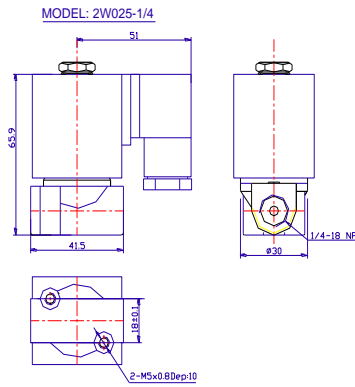
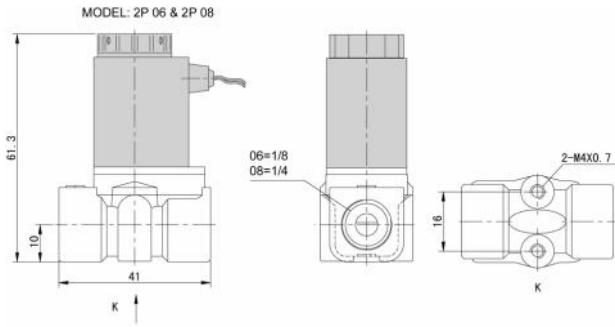

MODEL: 2W & 2S 160-500 SERIES VALVES  
UNIT IN MM (NOT TO SCALE)

Model: 2S & 2W Series (MM)		A	B	C	D	E	F
2S160-3/8	2W160-3/8	101.5	57	117	69	50	36
2S160-1/2	2W160-1/2	101.5	57	117	69	50	36
2S200-3/4	2W200-3/4	107.0	57	124	73	50	36
2S250-1	2W250-1	111.5	74	135	99	50	36
2S350-1 1/4	2W350-1 1/4	142.0	95	172	123	70.5	56
2S400-1 1/2	2W400-1 1/2	142.0	95	172	123	70.5	56
2S500-2	2W500-2	172.0	123	209	168	70.5	56

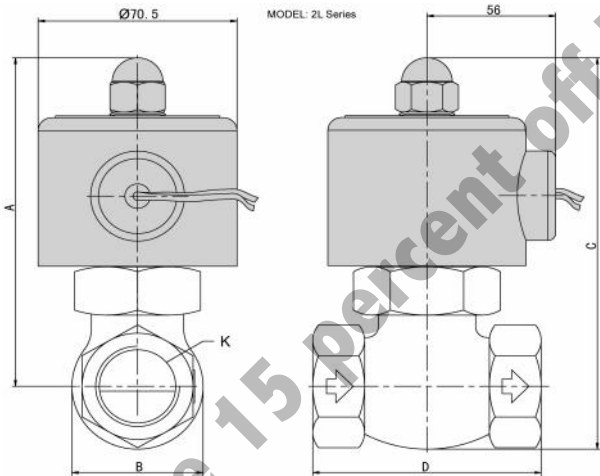

Model: 2L Series (MM)					
	A	B	C	D	K
2L170-3/8	125	42	146	82	3/8
2L170-1/2	125	42	146	82	1/2
2L170-3/4	125	42	146	82	3/4
2L200-1	136	52	162	91	1
2L300-1 1/4	148	74	185	111	1 1/4
2L300-1 1/2	148	74	185	111	1 1/2
2L500-2	176	86	223	163	2

2T

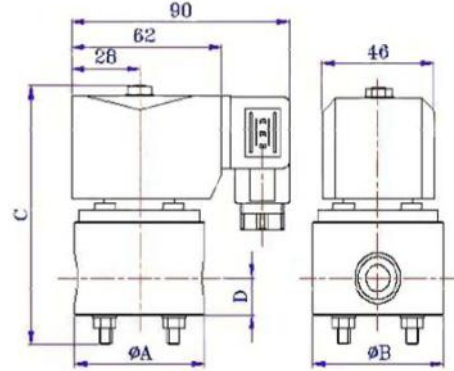

2MO/2MSO

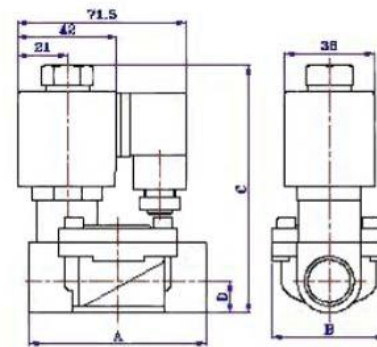

Valve Size	3/8	1/2	3/4	1	1 1/4	1 1/2	2
A	73	73	83	100	130	130	156
B	48	48	60	70	92	92	113
C	93	93	104	116	130	130	145
D	13.5	13.5	16.5	21	28.5	28.5	34

# STC Solenoid Valve Dimensions



## Dimensions

2H012-032

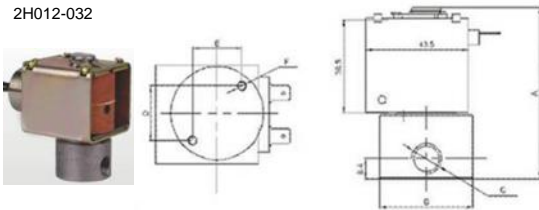

High Performance, high pressure, fast response, direct acting solenoid valve, Stainless steel wetted surfaces.

MODEL	PORT	ORIFICE	A	B	C	D	E	F	Pressure	Temperature
2H012	1/8"	1.2MM	65.5	30	1/8"	17	15.5	M4	1000 PSI	0-85°C
2H016	1/8"	1.6MM	65.5	30	1/8"	17	15.5	M4	500 PSI	0-85°C
2H016	1/4"	1.6MM	72	38	1/4"	23	21	M4	500 PSI	0-85°C
2H024	1/8"	2.4MM	65.5	30	1/8"	17	15.5	M4	300 PSI	0-85°C
2H024	1/4"	2.4MM	72	38	1/4"	23	21	M4	300 PSI	0-85°C
2H032	1/8"	3.2MM	65.5	30	1/8"	17	15.5	M4	150 PSI	0-85°C
2H032	1/4"	3.2MM	72	38	1/4"	23	21	M4	150 PSI	0-85°C

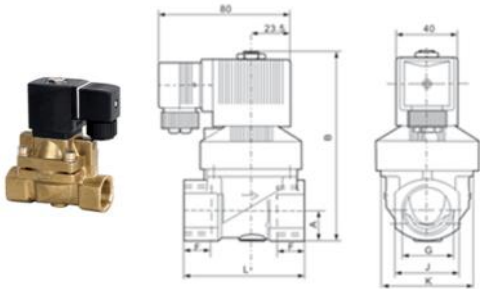

High pressure brass solenoid valve Dimensions (mm)

2H	2H	Port	Orifice	A	B	E	F	J	K	L
2H080	2HO080	1/4"	8	16	97	24	12	40	34	65
2H100	2HO100	3/8"	10	16	97	24	12	40	34	65
2H160	2HO160	1/2"	13	16	97	24	12	40	34	65
2H200	2HO200	3/4"	20	20	124	45	16	40	60	90
2H250	2HO250	1"	25	20	124	58	18	40	70	116

2H120-150

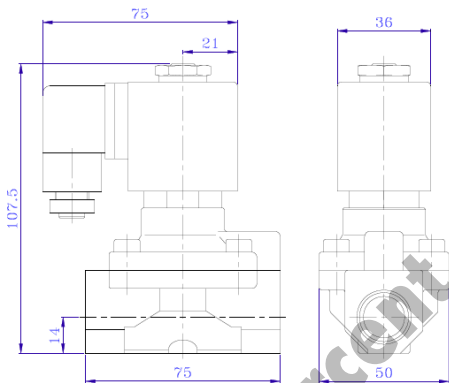

★ Overall Dimension

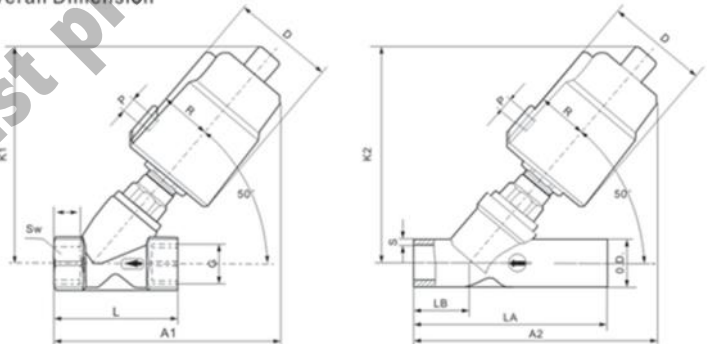

2HO120-150

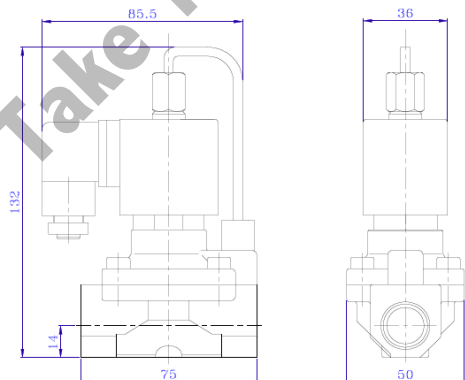

Specification	Actuator (mm)	D	R	P	Thread				Welded							
					G	K1(mm)	A1(mm)	L(mm)	T(mm)	SW(mm)	O.D(mm)	K2(mm)	A2(mm)	LA(mm)	LB(mm)	S(mm)
DN10	40	45.5	27	G1/8"	G3/8"	115	120	68	12	26.6	-	-	-	-	-	-
DN10	50	60	35	G1/8"	G3/8"	126	133	68	12	26.6	-	-	-	-	-	-
DN15	40	45.5	27	G1/8"	G1/2"	115	120	68	15	26.6	21.3	115	128	110	30	2.65
DN15	50	60	35	G1/8"	G1/2"	126	133	68	15	26.6	21.3	126	140	110	30	2.65
DN20	50	60	35	G1/8"	G3/4"	131	137	75	16	32	26.9	131	136	108	30	3.45
DN25	50	60	35	G1/8"	G1"	140	149	90	17	39.5	33.7	140	150	112	32	3.85
DN25	63	77	43	G1/8"	G1"	165	174	90	17	39.5	33.7	165	175	112	32	3.85
DN32	63	77	43	G1/8"	G1-1/4"	175	188	116	21	50	38	175	193	136	40	3.35
DN32	80	98	52	G1/4"	G1-1/4"	185	203	116	21	50	38	185	206	136	40	3.35
DN32	100	121	63	G1/4"	G1-1/4"	205	215	116	21	50	38	205	218	136	40	3.35
DN40	63	77	43	G1/8"	G1-1/2"	178	190	116	21	55.3	42	178	193	146	40	3.2
DN40	80	98	52	G1/4"	G1-1/2"	187	204	116	21	55.3	42	187	207	146	40	3.2
DN40	100	121	63	G1/4"	G1-1/2"	208	216	116	21	55.3	42	208	219	146	40	3.2
DN50	63	77	43	G1/8"	G2"	184	203	138	22	70	54	184	206	160	45	2.7
DN50	80	98	52	G1/4"	G2"	195	218	138	22	70	54	195	220	160	45	2.7
DN50	100	121	63	G1/4"	G2"	215	230	138	22	70	54	215	232	160	45	2.7

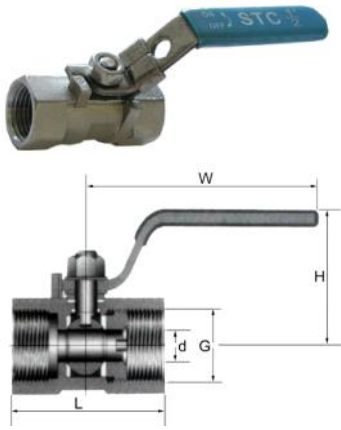

Model: V1 Specifications	
One Piece Reduced Port 316 Stainless Steel Ball Valve	
Maximum Operating Pressure: 1000 PSIG @ 100°F WOG*	
Operating Temperature Range: -60 to 450°F*	
End Connections: NPT Threaded with Padlocking device	

Dimensions (mm)					
SIZE	d	L	H	W	Wt (kg)
1/4"	5	39	35	64	0.07
3/8"	7	44	37	70	0.1
1/2"	9.2	56.5	43.5	90	0.16
3/4"	12.5	58	47	90	0.25
1"	15	70	50	103	0.43
1 1/4"	20	78	57	103	0.7
1 1/2"	24.5	83	69	127	0.83
2"	32	100	74.5	127	1.5

Main Parts and Materials			
No	Part Name	Material	Qty
1	SEAT	PTFE	2
2	BALL	SS316	1
3	JOINT GASKET	PTFE	1
4	CAP	SS316	1
5	BODY	SS316/CF8M	1
6	STEM	SS316	1
7	THRUST WASHER	PTFE	1
8	STEM PACKING	PTFE	1
9	GLAND NUT	SS304	1
10	STEM WASHER	SS304	1
11	STEM NUT	SS304	1
12	HANDLE COVER	PLASTIC	1
13	HANDLE	SS304	1

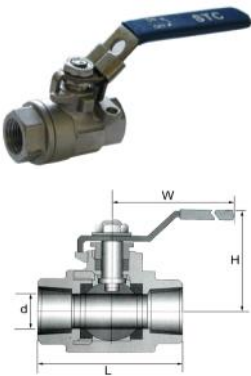

Model: V2 Specifications	
Two Piece Full Port 316 Stainless Steel Ball Valve	
Maximum Operating Pressure: 1/4" to 2" 1000 PSIG @ 100°F WOG* 2 1/2" to 3" 800 PSIG @ 100°F WOG*	
Temperature Range: -60 to 450°F*	
End Connections: NPT Threaded with Padlocking & Panel Mount Device	

Dimensions (mm)										
SIZE	1/4"	3/8"	1/2"	3/4"	1"	1 1/4"	1 1/2"	2"	2 1/2"	3"
d	11.6	12.7	15	20	25.4	32	38	50.8	65	76
L	55	55	63.5	75	88	103	110	124	167	192
H	48	48	50	57	69	73	83	92	136	149
W	103	103	103	125	145	145	190	190	250	250

Main Parts and Materials			
No	Part Name	Material	Qty
1	SEAT	PTFE	2
2	BALL	SS316	1
3	JOINT GASKET	PTFE	1
4	CAP	SS316	1
5	BODY	SS316/CF8M	1
6	STEM	SS316	1
7	THRUST WASHER	PTFE	1
8	STEM PACKING	PTFE	1
9	GLAND NUT	SS304	1
10	STEM WASHER	SS304	1
11	STEM NUT	SS304	1
12	HANDLE COVER	PLASTIC	1
13	HANDLE	SS304	1

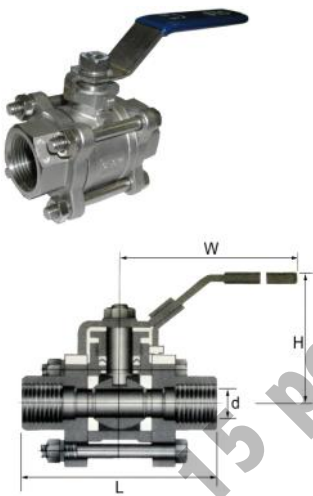

Model: V3 Specifications	
Maximum Operating Pressure: 1/2" to 2" 1000 PSI @ 100°F WOG* 2 1/2" to 3" 800 PSI @ 100°F WOG*	
Temperature Range: -60 to 450°F*	
Full Port	
End Connections: FNPT	
Mounting Options: Padlocking device and actuator mounting bracket	

Dimensions (mm)											
SIZE	1/4"	3/8"	1/2"	3/4"	1"	1 1/4"	1 1/2"	2"	2 1/2"	3"	4"
d	mm 12.5	12.5	15	20	25	30	38	50	64	80	98
	in 0.49	0.49	0.59	0.79	0.98	1.18	1.5	1.97	2.52	3.15	3.86
H	mm 57	57	68	70	80	84	93	100	142	155	172
	in 2.24	2.24	2.68	2.76	3.15	3.31	3.66	3.94	5.59	6.1	6.77
W	mm 96	96	124	124	142	142	202	202	250	250	300
	in 3.78	3.78	4.88	4.88	5.99	5.99	7.95	7.95	9.84	9.84	11.81
L	mm 68	68	72	83	90	112	120	147	174	193	216
	in 2.56	2.56	2.84	3.35	3.62	4.33	4.48	5.59	6.85	7.6	8.5

Main Parts and Materials			
No	Part Name	Material	Qty
1	SEAT	PTFE	2
2	BALL	SS316	1
3	JOINT GASKET	PTFE	1
4	CAP	SS316	1
5	BODY, BODY CONNECTOR	SS316/CF8M	1, 2
6	STEM	SS316	1
7	THRUST WASHER	PTFE	1
8	STEM PACKING	PTFE	1
9	GLAND NUT	SS304	1
10	STEM WASHER	SS304	1
11	STEM NUT	SS304	1
12	HANDLE COVER	PLASTIC	1
13	HANDLE	SS304	1
14	BODY CONNECTOR BOLT	SS304	4
15	BODY CONNECTOR NUT & WASHER	SS304	4

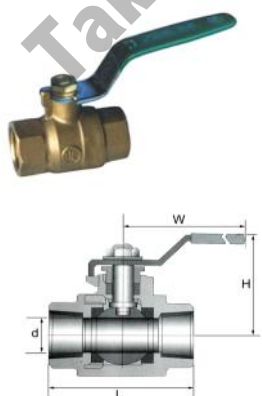

Model: T101 Specifications	
Maximum Operating Pressure	600 PSI , Gas & LPG 250 PSI
Temperature Range	-30 to 120 °C*
Port	Full Port
End Connections	FNPT
Service	Water, Oil, Gas,
Certification	UL Listed

Dimensions (mm)										
SIZE	1/4"	3/8"	1/2"	3/4"	1"	1 1/4"	1 1/2"	2"	2 1/2"	3"
d	11.6	12.7	15	20	25.4	32	38	50.8	65	76
L					88	86	95			
H					69	77	85			
W					145	138	137			

Main Parts and Materials			
No	Part Name	Material	Qty
1	SEAT	PTFE	2
2	BALL	Chrome Plated Brass	1
3	JOINT GASKET	PTFE	1
4	BODY	Brass	1
5	STEM	Brass	1
6	THRUST WASHER	Brass	1
7	STEM PACKING	PTFE	1
8	STEM NUT	Brass	1
9	HANDLE COVER	PLASTIC	1
10	HANDLE	Plated Steel	1



# STC Valve Technical Data

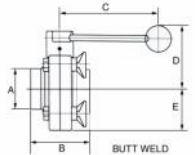

Model: VBS01 Specifications	
Size:	1/2" to 4"
Full Port	
Connection Options:	Butt weld, Clamp, or Male Thread, Female Ends (RJT, IDF, DIN, SMS)
Operating Pressure:	-13 PSIG to 150 PSIG WOG*
Temperature Range:	-10°C to 150°C with Silicone, or Viton*
Disc Head Size:	9.4 mm (to fit actuator)
Operator Options:	Lever, Actuators
Body Material Options:	316SS, or 316L SS
Handle:	304 SS/Plastic
Seat Options:	Silicone, EPDM or Viton

Dimensions (mm)						
A	B	B	B	C	D	E
Size	Weld	Clamp	Bevel			
1"	47.63	88.9	122.24	100	74	39
1 1/2"	47.63	88.9	134.94	110	47	39
2"	52.39	95.25	163.51	110	83.5	49.5
2 1/2"	53.98	96.84	174.63	110	93	58.5
3"	61.91	104.78	196.26	159	98	66
4"	79.38	122.24	228.6	159	118	84.5

Main Parts and Materials		
No	Part Name	Material
1	BODY	SS316 or SS316L
2	STEM WASHER	SS304
3	STEM NUT	SS304
4	HANDLE	304 SS/Plastic
5	GASKET	Silicone, EPDM, or Viton
6	BODY CONNECTOR BOLT	SS304
7	BODY CONNECTOR NUT & WASHER	SS304
8	BUTTERFLY	SS316/SS316L

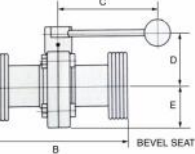
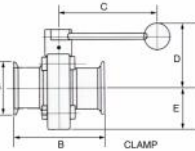

Model: V3C Specifications	
Sanitary Stainless Steel Ball Valve: These valves are made with precision machined Teflon seat for use in Sanitary applications. They are three piece design and have four bolts that permit quick and easy access to service the valve without disrupting the pipe line connections.	
Maximum Operating Pressure:	1/2" to 2" 1000 PSI @ 100°F WOG* 2 1/2" to 4" 800 PSI @ 100°F WOG*
Temperature Range:	-60 to 450°F*
Full Port	
End Connections:	Clamp End
Mounting Options:	Padlocking device and actuator mounting bracket

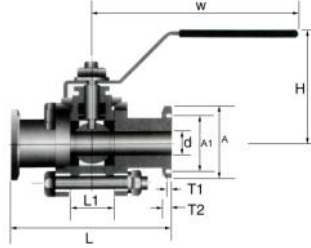

Dimensions (mm)								
Size	Port (d)	L	A	A1	H	T1	T2	W
1/2"	9.6	75	25	20.24	64	--	3.63	125
3/4"	15.9	90	25	20.24	67	--	3.63	125
1"	22.2	100	50.4	43.6	83	2.85	4.75	140
1 1/4"	28.5	110	50.4	43.6	89	2.85	4.75	140
1 1/2"	34.9	125	50.4	43.6	100	2.85	--	200
2"	47.5	150	63.9	56.3	108	2.85	--	200
2 1/2"	60.2	190	77.4	70.6	150	2.85	--	250
3"	72.9	220	90	83.3	161	2.85	--	250
4"	97.4	270	118.9	110.3	180	2.85	--	250

Main Parts and Materials			
No	Part Name	Material	Qty
1	SEAT	PTFE	2
2	BALL	SS316	1
3	JOINT GASKET	PTFE	1
4	CAP	SS316	1
5	BODY, BODY CONNECTOR	SS316/CF8M	1, 2
6	STEM	SS316	1
7	THRUST WASHER	PTFE	1
8	STEM PACKING	PTFE	1
9	GLAND NUT	SS304	1
10	STEM WASHER	SS304	1
11	STEM NUT	SS304	1
12	HANDLE COVER	PLASTIC	1
13	HANDLE	SS304	1
14	CONNECTOR BOLT	SS304	4
15	CONNECTOR NUT & WASHER	SS304	4

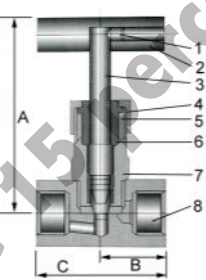

Model: VN01 Specifications	
End Connections:	NPT threaded ASME b1.20.1
DIN 2999 & BS21:	ISO 228/1 & ISO 7/1
Max. Operating Pressure:	6000 PSIG @ 100 °F*
Operating Temperature Range:	-60 to 450°F*
Fire safe design	

Dimensions (mm)						
Size	1/8"	1/4"	3/8"	1/2"	3/4"	1"
A	75	75	75	87	90	103
B	25	25	25	30	32.5	40
C	50	50	50	60	65	80
Cv	0.43	0.43	0.74	1.36	2.64	3.6

Main Parts and Materials		
No	Part Name	Material
1	SET SCREW	SS304
2	HANDLE	SS410
3	STEM	SS316
4	GLAND NUT	SS304
5	GLAND	SS304
6	PACKING	TEFLON
7	BONNET	SS316/CF8M
8	BODY	SS316/CF8M

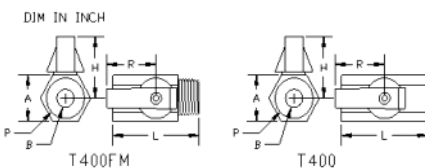

Valve Specifications		
Valve Type	T400	T400FM
Operating Pressure	0-450 PSI @ 75 °F	
Operating Temperature	0 TO 200 Deg. F	
Ball	Chrome Plated Brass	
Body Materials	Chrome or Nickel Plated	
Seal Materials	PTFE	
Handel	Metal or Plastic	
Service	Air, Liquid	

	A	B (BORE)	H	L	P (NPT)	R
T400 1/4	0.80	0.31	1.00	1.58	1/4	0.93
T400 3/8	0.80	0.31	1.00	1.58	3/8	0.93
T400 1/2	0.96	0.39	1.10	1.78	1/2	0.93
T400FM 1/4	0.80	0.31	1.00	1.58	1/4	0.93
T400FM 3/8	0.80	0.31	1.00	1.58	3/8	0.93
T400FM 1/2	0.96	0.39	1.10	1.78	1/2	0.93

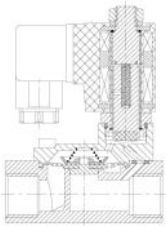
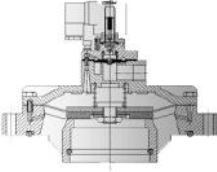
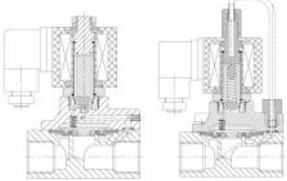
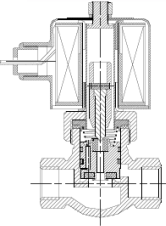
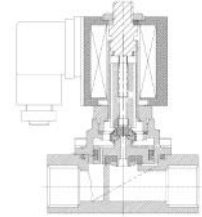
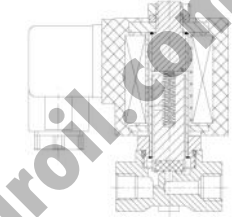
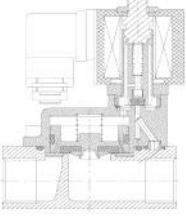
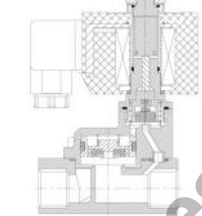
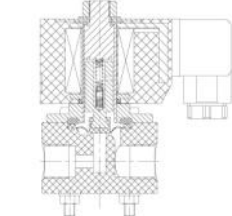
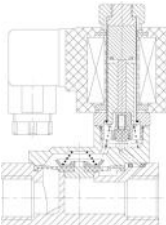
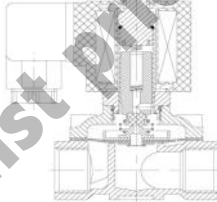
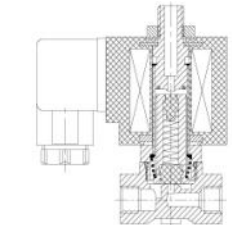

<b>2C:</b> Brass  2 Way NC Latching SV		<b>2D:</b> Aluminum  2 Way NC Pilot Diaphragm		<b>2H/2HO120-130:</b> Brass  2 Way NC/NO Pilot Diaphragm	
<b>2L:</b> Brass  2 Way NC Direct Lift Piston		<b>2LS:</b> Stainless Steel  2 Way NC Direct Lift Piston		<b>2H:</b> Stainless <b>2P:</b> Plastic <b>2V:</b> Aluminum <b>2S/25-040:</b> SS <b>2W/25-040:</b> Brass  2 Way NC Direct Acting	
<b>2MS:</b> Stainless Steel  2 Way NC Pilot Piston		<b>2MSO:</b> Stainless Steel  2 Way NO Pilot Piston		<b>2T:</b> Teflon  2 Way NC Direct Lift Diaphragm	
<b>2V130:</b> Brass  2 Way NC Pilot Diaphragm		<b>2W/2WO160-500:</b> Brass <b>2S/2SO160-500:</b> SS  2 Way NC Direct Lift Diaphragm		<b>3W:</b> Brass  3 Way NC Direct Acting	
Valve Components	Materials	Seals Options:	Temperature Range/Compatibility		
Body	Options: Aluminum, Brass, Plastic, Stainless Steel, Teflon	NBR	-10~90°C, Oil-resistant and petroleum-resistant, not good for oxygen		
Armature Tube	Stainless Steel 304	EPDM	-30~130°C, Withstand ozone, resistant to corrosive chemical materials, not suitable for oil		
Plunger	Stainless Steel 430F	PTFE	-20~200°C, Resistant to most chemicals, except compound with oxygen		
Head	Stainless Steel 430F	VITON	-10~150°C, Resistant to most chemicals		
Springs	Stainless Steel 304				
Shading Rings	Stainless Steel 304/Brass				

## 2KS/2KD

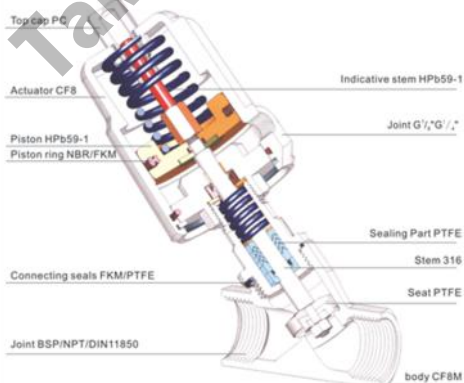

Model: 2KS/2KD	Stainless steel body
1	Transparent Cap PC/PSU
2	Pilot air ports Stainless Steel 1.4305
3	Actuator PA/B66
4	Cylindrical seal NBR/FPM
5	Spring Stainless Steel 1.4310
6	Tube Stainless Steel 1.4301
7	V-seals PTFE, FPM
8	Wiper PTFE
9	Nipple Stainless Steel 1.4401
10	Spindle Stainless Steel 1.4401
11	Pins Stainless Steel 1.4401
12	Swivel plate Stainless Steel 1.4401
13	Seal PTFE
14	Valve body Stainless steel 1.4408 (Threaded connection) Stainless steel 1.4581 (weld end connection)

# Manual Air Valves

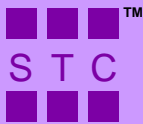

Precision Engineered

Fine Quality



Advanced Design

Excellent Prices



### Contents

STC Manual Air Valve Numbering System.....	E2
STC Air Valve Specifications.....	E2
STC Manual Air Valves List Price.....	E3
STC Manual Air Valve Dimensions.....	E4-8

### STC Manual Air Valve Numbering System

Ordering Part No. =  
(eg. 4H230C-S)

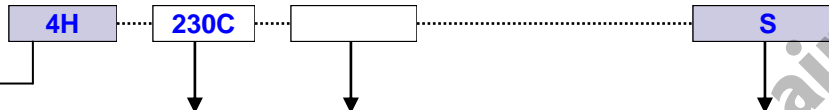

Model	# Way & # Position	PORT SIZE (NPT)	Options
Manual Air Valves	<b>MOV</b> 3 Way 2 Position	Blank = 1/8	Blank = Plunger (Non-Detented), E = Palm Button (Detented), PB=Palm Button (Non-Detented), PPL = Push Button (Non-Detented), R = Roller Lever (Non-Detented), TB = Knob Switch (Detented), Color: B=Blue, G=Green, K=Black, R=Red, Y=Yellow
Manual Air Valves	<b>MSV</b> 96322 = 3 Way 2 Position 86522 = 4 Way 2 Position	Blank = 1/4	
Hand Lever Valves	<b>TSV</b>		
Hand Lever Valves	<b>4H</b> 230C = 4 Way 3 Position (Closed Center) 230E = 4 Way 3 Position (Exhaust Center) 230P = 4 Way 3 Position (Pressure Center)		M = DETENTED S = NON-DETENTED (Spring Return)
Pull/Push Valves	<b>3R</b> 210 = 3 Way 2 Position <b>4R</b> 210 = 4 Way 2 Position		
Hand Handle Valves	<b>HV</b> 400 = 4 Way 3 Position 410 = 4 Way 2 Position		Blank = Detented
Foot Operated Valves	<b>FV</b> 220 = 2 Way 2 Position 320 = 3 Way 2 Position 420 = 4 Way 2 Position		Blank = Non-Detented
	<b>4F</b> 210 = 4 Way 2 Position		Blank = Non-Detented, L = Detented (with lock), G = Guard









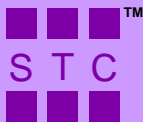

















### STC Air Valve Specifications

Specifications								
Model	MSV Series	MOV Series	TSV Series	4H Series	3-4R Series	HV Series	4F Series	FV Series
Description	Hand Valves	Hand Valves	Lever Valves	Lever Valves	Pull/Push	Hand Valves	Foot Valves	Foot Valves
Cv	0.89	0.67	1.0	0.89	0.89	1.68		
Operating Pressure	0 to 150 PSI							
Operating Temperature	23 to 140 Deg. F (-5 to 60 Deg. C)							
Action	Direct Acting							
Working Medium	40 micron filtered air or inert gas							
Body Material	Aluminum							
Seal Material	NBR							
Lubrication	Not Required							

Specifications			
Model	ASC Series	QE Series	ST Series
Description	Flow Control Valves	Quick Exhaust Valves	Shuttle Valves
Operating Pressure	0 to 140 PSI		
Operating Temperature	32 to 140 Deg. F (0 to 60 Deg. C)		
Working Medium	40 micron filtered air or inert gas		
Body Material	Aluminum		
Seal Material	NBR		
Lubrication	Not Required		

# Manual Air Valves



1/4" NPT 4 Way 5 Port 2 Position Air Valves								
Model Price	MSV86522TB \$28.71	MSV86522EB \$28.71	MSV86522PB \$28.71	MSV86522PP \$28.71	MSV86522R \$28.71	MPV86522 \$37.23	TSV86522 (M or S) \$30.25	4R210(M or S) \$20.30
Description	Two Position Detented Switch Cv 0.89	Emergency Stop Detented Cv 0.89	Palm Button Momentary Cv 0.89	Push Button Momentary Cv 0.89	Roller Lever Cv 0.89	Toggle Switch Cv 0.89	Lever M = Detented S = Non-detented	Pull/Push M = Detented S = Non-detented
1/4" NPT 3 Way 3 Port 2 Position Air Valves								
Model Price	MSV98322TB \$27.23	MSV98322EB \$27.23	MSV98322PB \$27.23	MSV98322PP \$27.23	MSV98322R \$27.23	MPV98322 \$37.23	TSV98322 (M or S) \$28.71	3R210(M or S) \$19.80
Description	Two Position Switch Cv 0.89	Emergency Stop Detented Cv 0.89	Palm Button Momentary Cv 0.89	Push Button Momentary Cv 0.89	Roller Lever Momentary Cv 0.89	Toggle Switch Cv 0.89	Lever M = Detented S = Non-detented	Pull/Push M = Detented S = Non-detented
1/8" NPT 3 Way 2 Port 2 Position Air Valves					1/4" NPT Mechanical Air Valves			
Model Price	MOV-01 \$17.33	MOV-03 \$17.33	MOV-03A \$17.33	MOV-02 \$15.84		Model Price		4H230C (M or S) \$56.94
Description	Two Position Switch Cv 0.67	Emergency Stop Detented Cv 0.67	Push Button Momentary Cv 0.67	Roller Lever Momentary Cv 0.67	Description		3 Position, 4 Way Closed Center M = Detented S = Non-detented	3 Position, 4 Way Pressure Center M = Detented S = Non-detented
1/4" NPT Air Valves								
Model Price	HV410 \$31.19	HV400 \$31.19		FV320 \$33.17	FV420 \$35.15	4F210 \$40.10	4F210L \$51.48	4F210G \$62.87
Description	2 Position 4 Way Valve Cv 1.68	3 Position 4 Way Valve Closed Center Cv 1.68		3 Way Momentary Foot Valve	4 Way Momentary Foot Valve	4 Way Momentary Foot Valve	4 Way Detented Foot Valve	4 Way Shielded Momentary Foot Valve

# Air Valve Dimensions

MODEL: MSV86522-XX

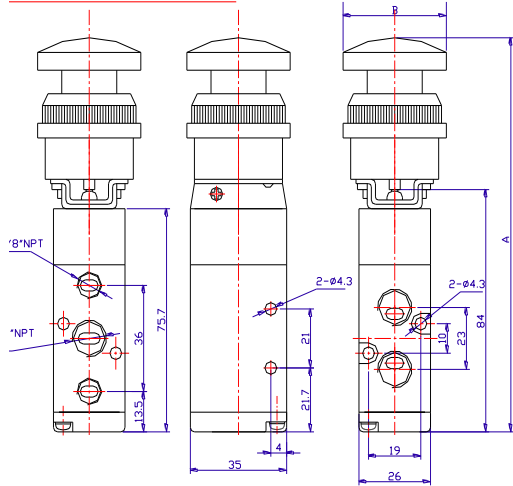

MODEL: MSV98322-XX

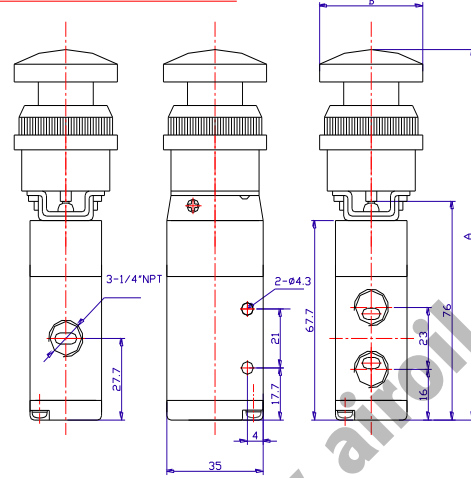

MODEL: MOV-XX

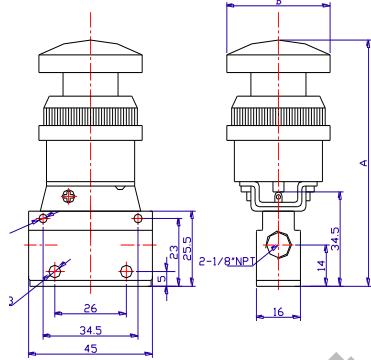

## BUTTON STYLE

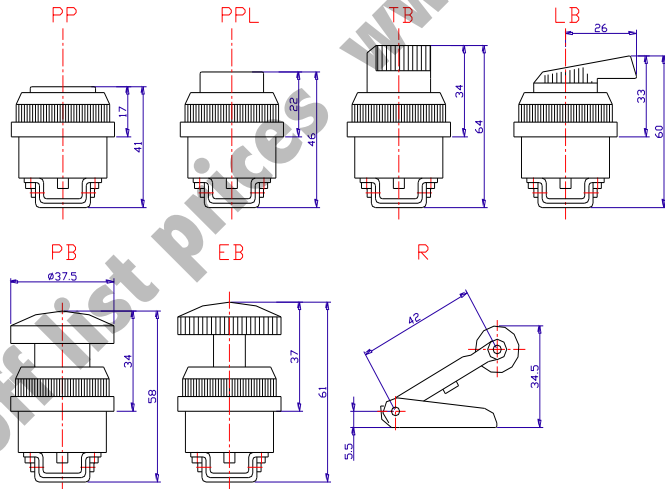

PANEL MOUNT HOLE SIZE 1 3/16" (30 MM)

4R210 Unit in mm

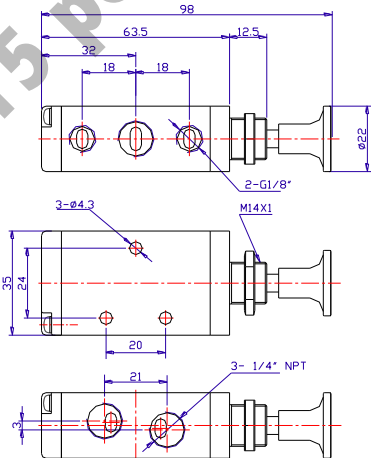

Unit in (mm)

3R210

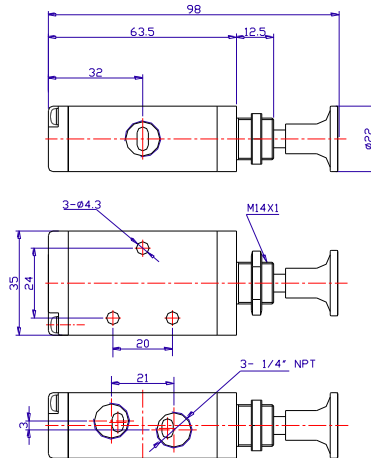



# Air Valve Dimensions

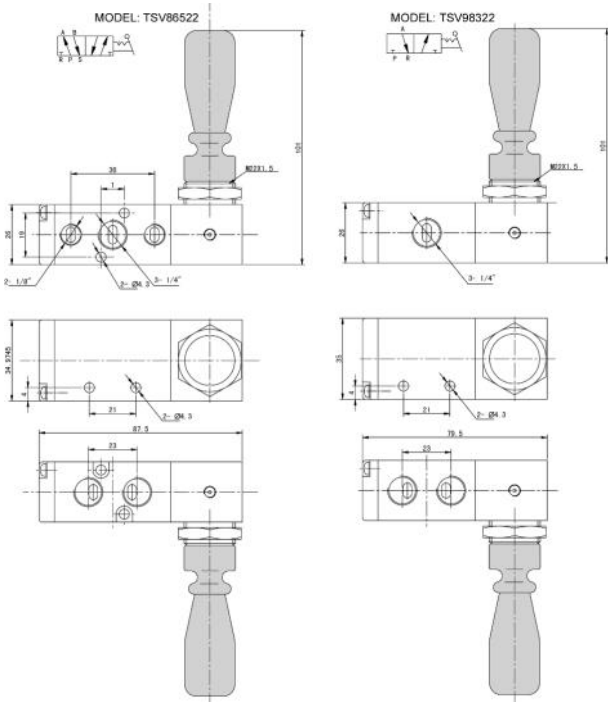

## MPV

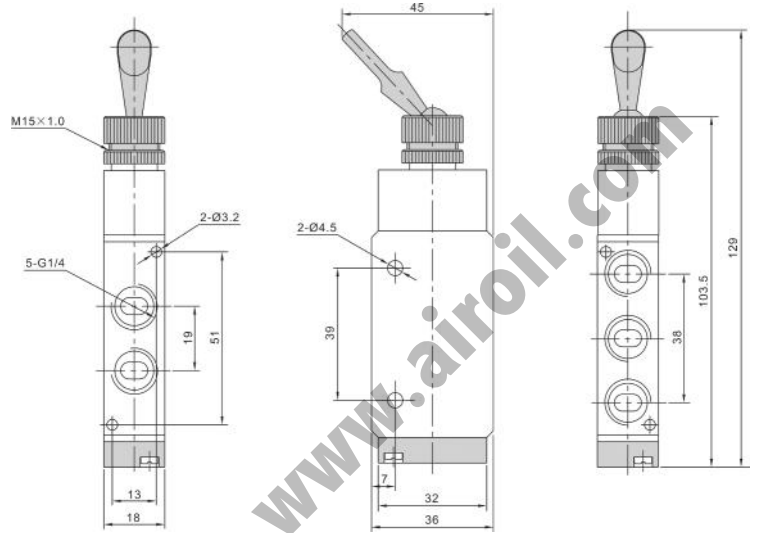

## MODEL: 4H230C-1/4

5 PORT 3 POSITION MOMENTARY HAND LEVER VALVE

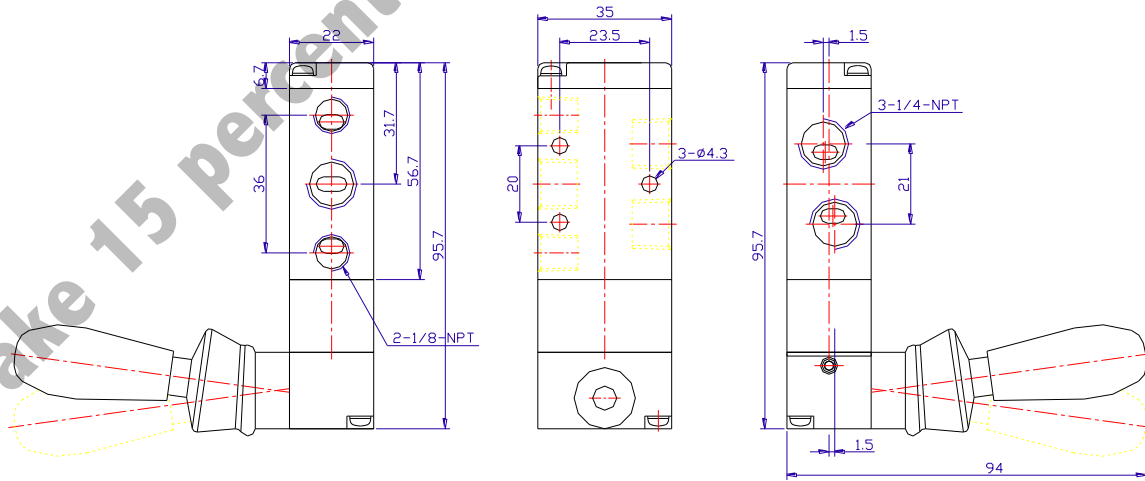
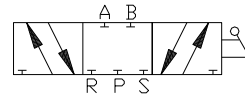

Unit in (mm)



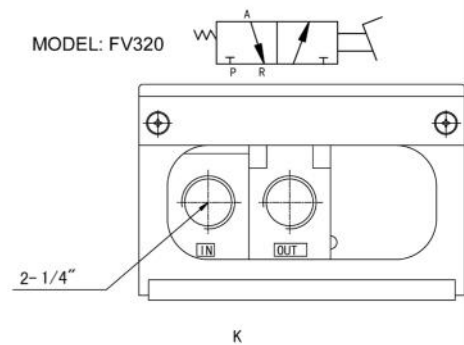
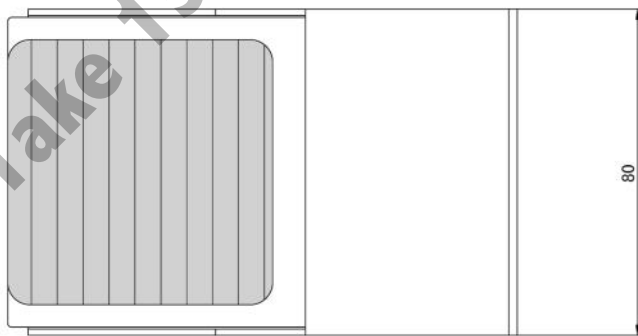
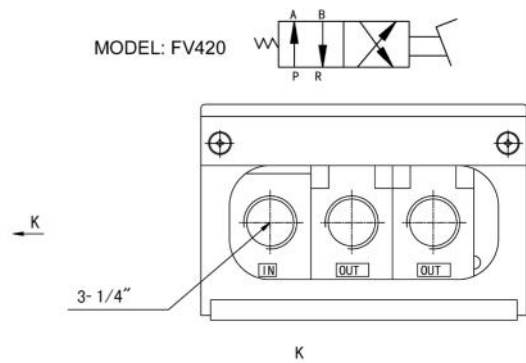
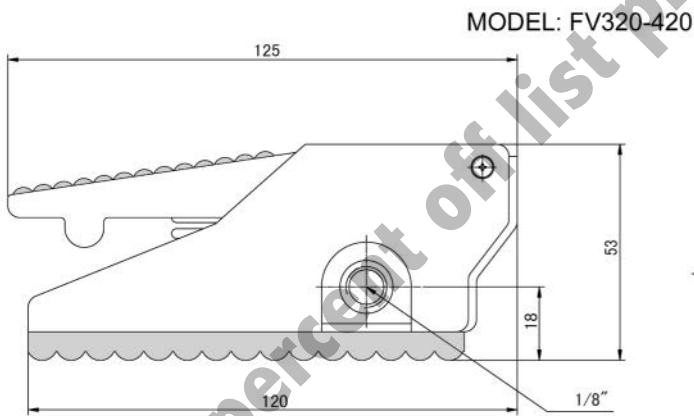
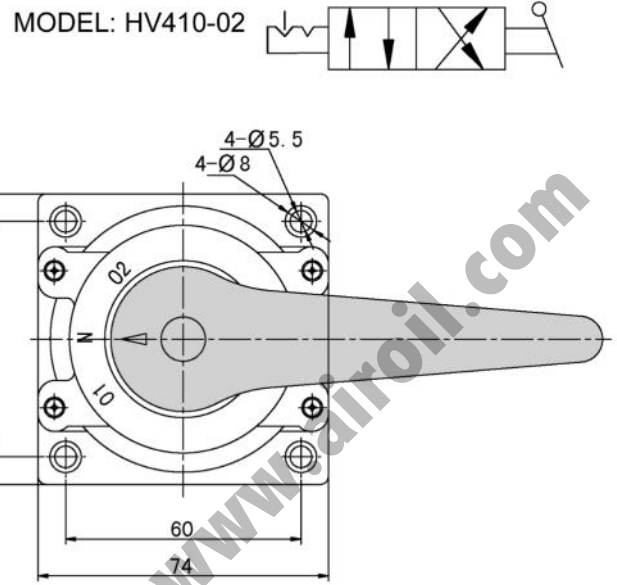
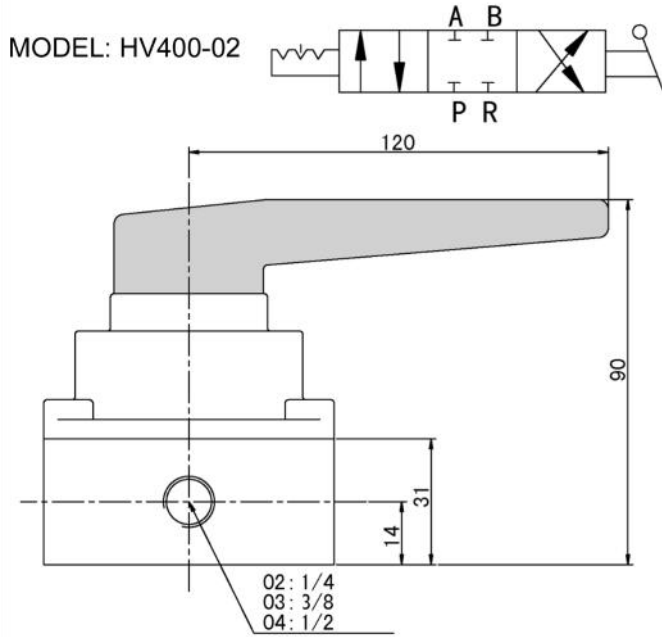

Unit in (mm)

# Air Valve Dimensions

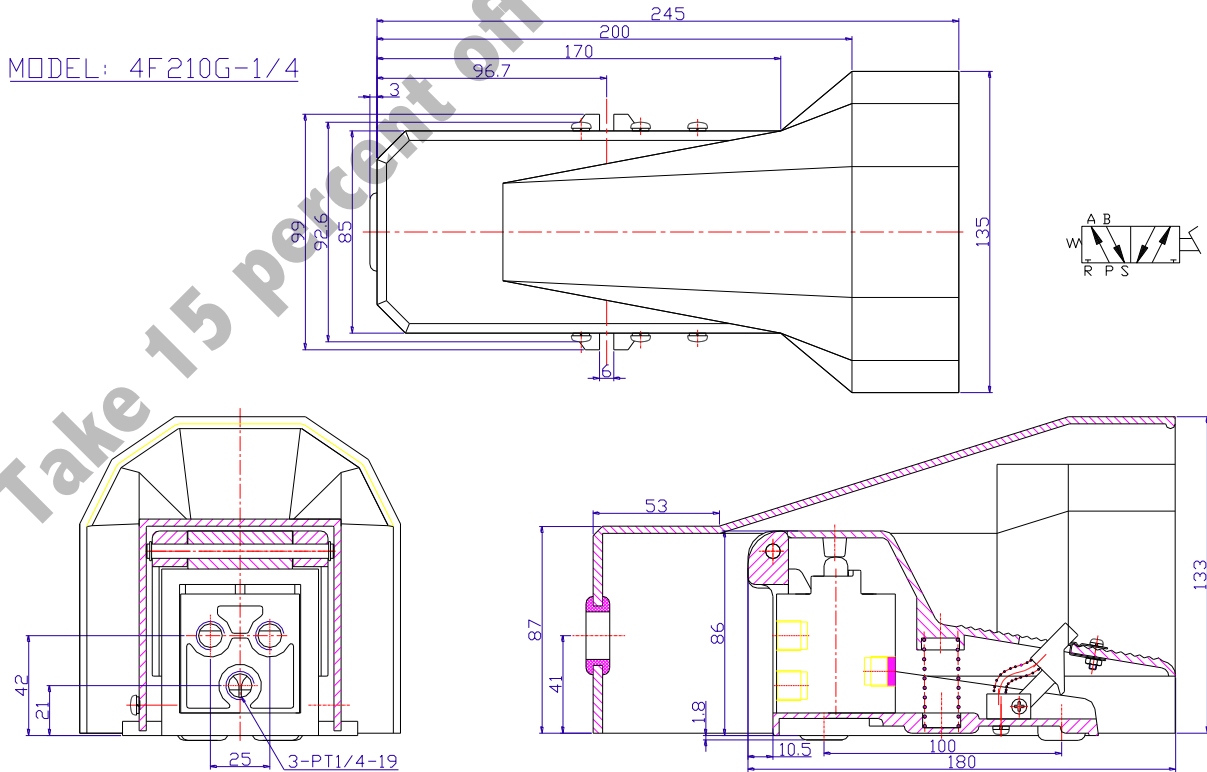
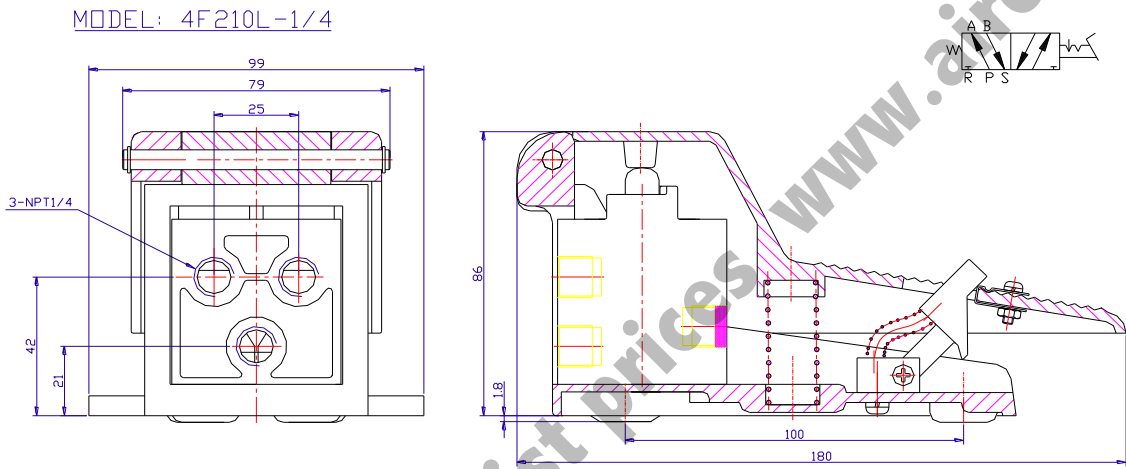
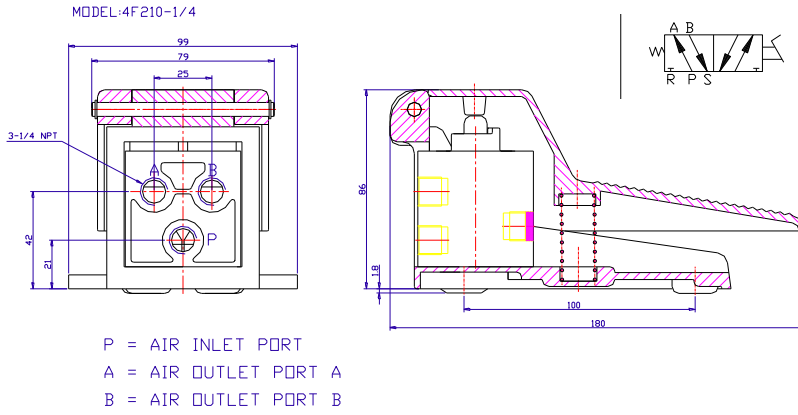

Unit in (mm)

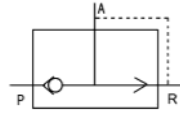
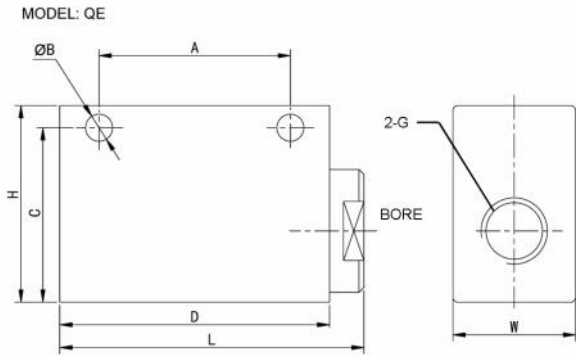

Quick Exhaust Valve (MM)									
	Bore (NPT)	G (NPT)	L	W	H	A	B	C	D
QE-01	1/4	1/8	46	20	32	30	4.3	27.0	40
QE-02	3/8	1/4	62	25	40	39	5.6	33.5	55
QE-03	1/2	3/8	62	25	40	39	5.6	33.5	55
QE-04	3/4	1/2	98	38	64	60	8.5	51.0	90
QE-06	1	3/4	98	38	64	60	8.5	51.0	90

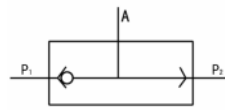
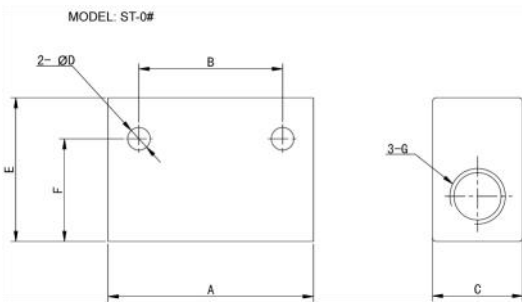

SHUTTLE VALVE (MM)							
	A	B	C	D	E	F	G (NPT)
ST-01	40	24	16	4.5	25	21	1/8
ST-02	50	35	22	5.5	35	25	1/4
ST-03	75	48	30	7.0	50	42	3/8
ST-04	75	48	30	7.0	50	42	1/2
ST-06	110	72	40	7.0	70	58	3/4
ST-08	110	72	40	7.0	70	58	1

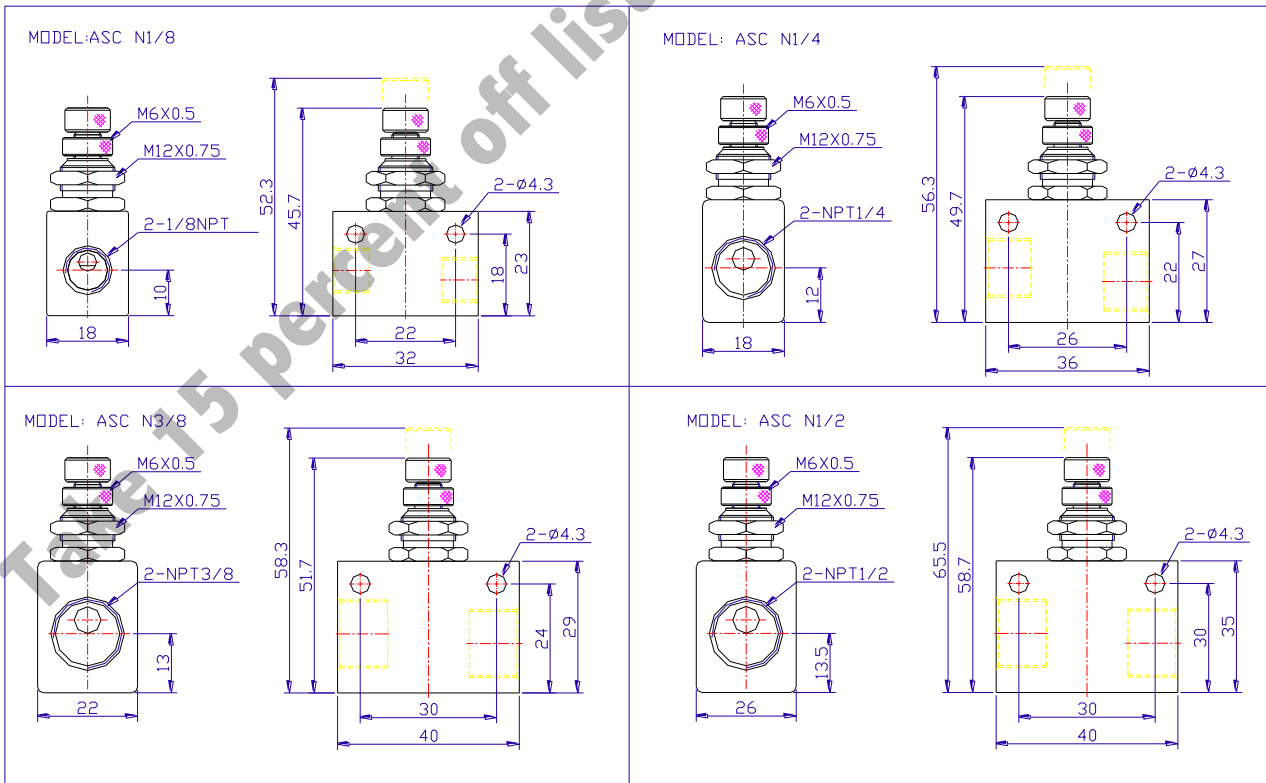

Unit in (mm)

# STC Air Cylinders

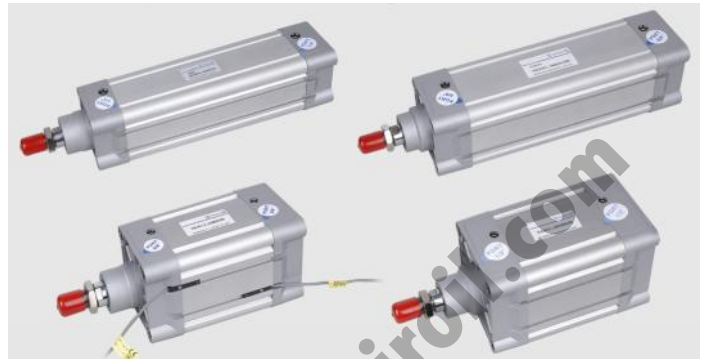
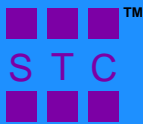

Fine Quality

Precision Engineered

Advanced Design

Excellent Prices

www.airvalve.com

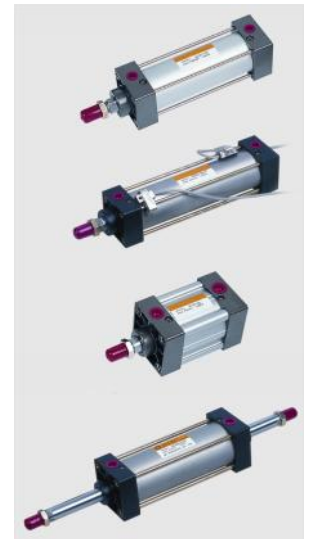

## Contents

STC Air Cylinder Numbering System.....	F2
Cylinder Mounting Bracket Dimensions.....	F3
MA & MAL Series Round Cylinder Dimensions.....	F4-5
SC &SU Series Tie Rod Cylinder Dimensions.....	F6
SDA Series Compact Cylinder Dimensions.....	F6
SDA/SSA/STA Series Compact Cylinder Dimensions.....	F7

## STC Air Cylinder Numbering System

Ordering Part No. =  
(eg. MA 16-25-SA)

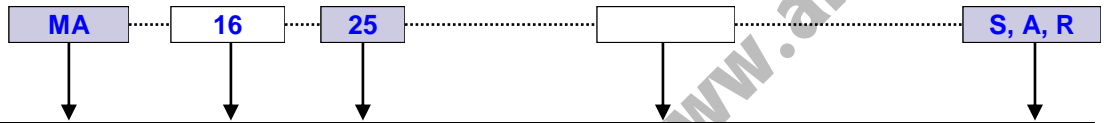

Model	Bore (mm)	Stroke (mm)	Mounting	Options
<b>MA Series Stainless Steel Round Cylinder</b>				
MA = Double Acting MAS = Single Acting MAD = Double Shaft MAJ = Double Shaft with Adjustable Stroke	16 20 25 32 40	25-500	Blank = Front Nose Mount and Back Pivot Mount (Standard)  U = Front Nose Mount  LB = Foot Mount	S = Magnet for Hall Sensor J = Adjustable Stroke Length (in MM) A = Air Cushion (Bumper Standard) R = Reed Switch 5-240 V (DC/AC) 100 mA 10W
<b>MAL Series Aluminum Round Cylinder</b>				
MAL = Double Acting MALS = Single Acting MALD = Double Shaft MALJ = Double Shaft with Adjustable Stroke	16 20 25 32 40	25-500		
<b>SC Series Tie-Rod Cylinder</b>				
SC = Double Acting SCA = Single Acting SCD = Double Shaft SCJ = Double Shaft with Adjustable Stroke	32 40 50 63 80 100 125 160 200	25-1000	FA = Front Flange Type	S = Magnet for Hall Sensor J = Adjustable Stroke Length (in MM) A = Air Cushion (Bumper Standard) R = Reed Switch 5-240 V (DC/AC) 100 mA 10W
<b>SU Series Enclosed Tie-Rod Cylinder</b>				
SU = Double Acting SUA = Single Acting SUD = Double Shaft SUJ = Double Shaft with Adjustable Stroke	32 40 50 63 80 100 125 160 200	25-1000	FB = Back Flange CA = Pivot Bracket with Pin CB = Clevis Bracket with Pin LB = Foot Mount TC = Swing Type	S = Magnet for Hall Sensor J = Adjustable Stroke Length (in MM) R = Reed Switch 5-240 V (DC/AC) 100 mA 10W
<b>SDA Series Compact Round Cylinder</b>				
SDA = Double Acting SSA = Single Acting STA = Reverse Acting SDAD = Double Shaft	12 16 20 25 32 40 50 63 80 100	25-1000	TCM = Swinging Type attaching foot seat	

Part No.	Description	Specifications
AL-11R-MA	Reed Switch for MA cylinder	Reed Switch 5-240 V (DC/AC) 100 mA 10W
AL-11R-MAL	Reed Switch for MAL cylinder	
AL-11R-SC	Reed Switch for SC cylinder	
AL-11R-SDA	Reed Switch for SDA cylinder	
AL-11R-SU	Reed Switch for SU cylinder	

# Cylinder Mounting Bracket Dimensions

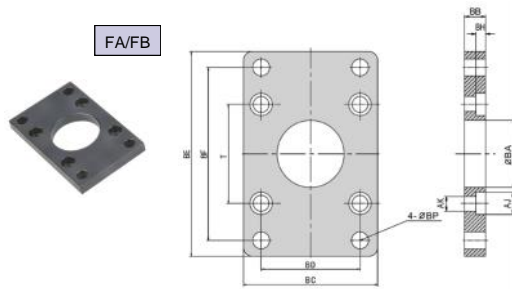

FA/FB (Front or Back Flange)									
Bore	32	40	50	63	80	100	125	160	200
BA	28.3	32.3	38.3	38.3	47.3	47.5	56	63	81
BB	10	10	10	12	16	16	20	25	25
BC	47	52	65	76	95	115	140	180	220
BD	33	36	47	56	70	84	90	115	135
BE	72	84	104	116	143	162	224	280	320
BF	58	70	86	98	119	138	180	230	270
BG	6.5	6.5	6.5	8.5	11	11	15	20	20
BH	11	11	14	14	17	17	19	25	25
AJ	6.5	6.5	8.5	8.5	11	11	13	17	17
BP	7	7	9	9	12	12	16	18	22
T	33	37	47	56	70	84	110	140	175

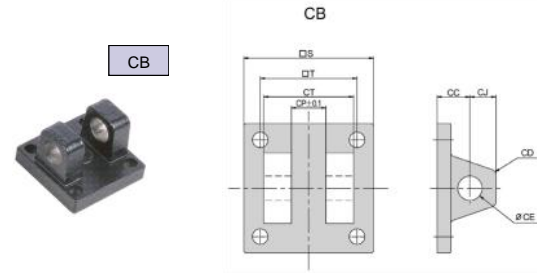

CB (Double Rear Clevis Bracket with Pin)									
Bore	32	40	50	63	80	100	125	160	200
CC	19	19	19	19	32	32	50	55	60
CD	5	5	3	3	8	8	25	30	30
CE	12	14	14	14	20	20	25	30	30
CJ	13	13	15	15	21	21	25	30	30
CP	16	21	20	20	32	32	70	90	90
CT	32	44	52	52	64	64	120	160	160
PAI	41	52	60	60	74	74	130	170	170
PBI	34	46	54	54	66	66	122	162	162
S	48	50	62	75	94	112	140	180	220
T	33	37	47	56	70	84	110	140	175

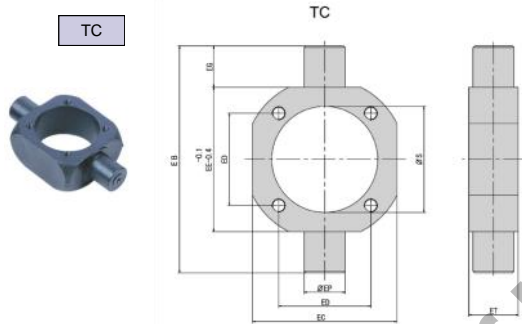

TC (Center Trunnion)									
Bore	40	50	63	80	100	125	160	200	
EB	113	126	138	164	182	210	264	336	
EC	63	76	88	114	132	160	200	240	
ED	37	47	56	70	84	110	140	175	
EE	63	76	88	114	132	160	200	240	
EG	25	25	25	25	25	25	32	48	
EP	25	25	25	25	25	25	32	38	
ET	30	30	30	30	30	30	38	44	
S	46	56	69	88	108	135	173	213	

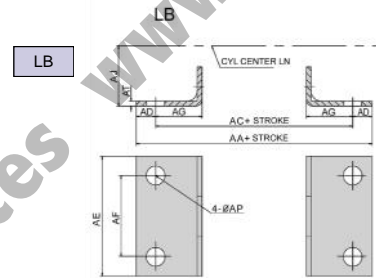

LB (Foot Mount)									
Bore	32	40	50	63	80	100	125	160	200
AA	153	169	173	184	200	210	249	328	380
AC	134	140	149	158	168	174	213	288	320
AD	9.5	15	12	12	16	18	18	20	30
AE	50	57	68	80	97	112	140	180	220
AF	33	36	47	56	70	84	90	115	135
AG	21	24	28	31	30	30	45	60	70
AJ	28	30	37	41	49	57	90	115	135
AP	9	12	12	12	14	14	16	18	22
AT	3.2	3.2	3.2	3.2	4	4	8	8	10

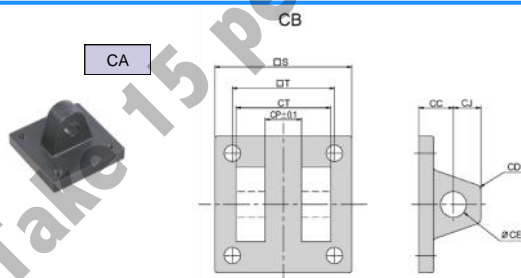

CA (Single Rear Clevis with Pin)									
Bore	32	40	50	63	80	100	125	160	200
S	48	50	62	75	94	112	140	180	220
T	33	37	47	56	70	84	110	140	175
DC	34	34	34	34	48	48	50	55	60
DD	14	14	15	15	20	20	25	30	30
DE	12	14	14	14	20	20	25	30	30
DL	14	14	15	15	20	20	25	30	30
DQ	16	20	20	20	32	32	70	90	90

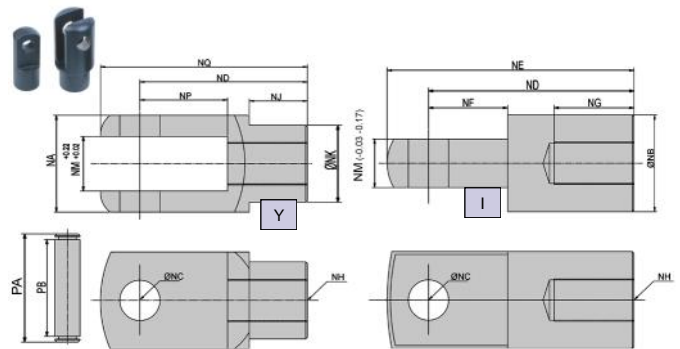

Y (Rod Clevis with Pin), I (Rod Pivot with Pin)															
	NA	NB	NC	ND	NE	NF	NG	NH	NJ	NK	NM	NP	NQ	PA	PB
32	19	20	10	40	52	15	20	M10X1.25	12	18	10	20	52	26	20
40	25	24	12	48	67	24	20	M12X1.25	20	23	12	24	62	33	27
50	32	32	16	64	89	32	23	M16X1.5	22	30	16	32	83	39	33
63	32	32	16	64	89	32	23	M16X1.5	22	30	16	32	83	39	33
80	44	40	20	80	112	40	30	M20X1.5	30	39	20	40	105	53	45
100	44	40	20	80	112	40	30	M20X1.5	30	39	20	40	105	53	45



# MA Series Stainless Steel Round Cylinder Dimensions

## MA-CA

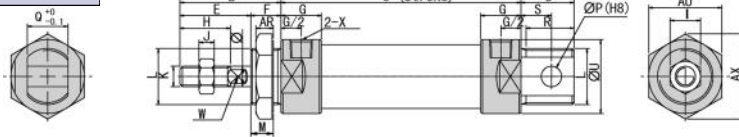

## MA-CM



## MA-U



Model: MA														
Bore	A	A1	A2	B	C	D	D1	E	F	G	H	I	J	K
16	114	114	98	38	60	15	15	22	16	10	16	10	5	M6 X 1
20	137	128	116	40	76	21	12	28	12	16	20	12	6	M8 X 1.25
25	141	134	120	44	76	21	14	30	14	16	22	17	6	M10 X 1.25
32	147	134	120	44	76	27	14	30	14	16	22	17	6	M10 X 1.25
40	149	136	122	46	76	27	14	32	14	16.7	24	17	7	M12 X 1.25
Bore	L	M	P	Q	R	R1	S	U	V	W	X	AR	AX	AY
16	M16 X 1.5	14	6	12	14	14	9	21	6	5	M5	6	24	28
20	M22 X 1.5	10	8	16	19	12	12	27	8	6	G1/8	7	33	29
25	M22 X 1.5	12	8	16	19	14	12	30	10	8	G1/8	7	33	29
32	M24 X 2.0	12	10	16	25	14	15	35	12	10	G1/8	8	37	32
40	M30 X 2.0	12	12	20	25	14	15	42	16	14	G1/8	9	47	41

## MSA-CA

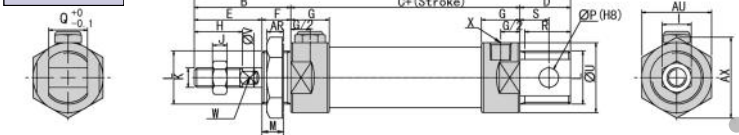

## MSA-CM

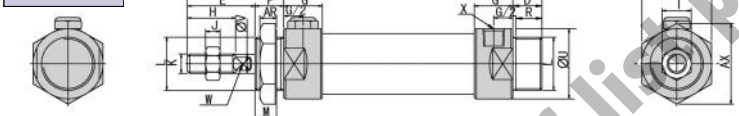

## MSA-U

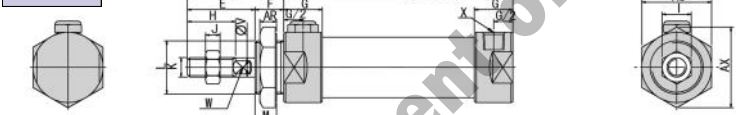

Symbol	A	A1	A2	B	C	D	D1	E	F	G	H	I				
Bore	0-50	51-100	0-50	51-100	0-50	51-100	B	0-50	51-100	D	D1	E	F	G	H	I
20	137	162	128	153	116	141	40	76	101.0	21	12	28	12	16	20	12
25	141	166	134	159	120	145	44	76	101.0	21	14	30	14	16	22	17
32	147	172	134	159	120	145	44	76	101.0	27	14	30	14	16	22	17
40	149	174	136	161	122	147	46	76	101.0	27	14	32	14	22	24	17

Symbol	J	K	L	M	P	Q	R	R1	S	U	V	W	X	AR	AX	AY	
Bore	20	6	M8 X 1.25	M22 X 1.5	10	8	16	19	12	12	27	8	6	G1/8	7	33	29
25	6	M10 X 1.25	M22 X 1.5	12	8	16	19	14	12	30	10	8	G1/8	7	33	29	
32	6	M10 X 1.25	M24 X 2.0	12	10	16	25	14	15	35	12	10	G1/8	8	37	32	
40	7	M12 X 1.25	M30 X 2.0	12	12	20	25	14	15	41.6	16	14	G1/8	9	47	41	

## MAD

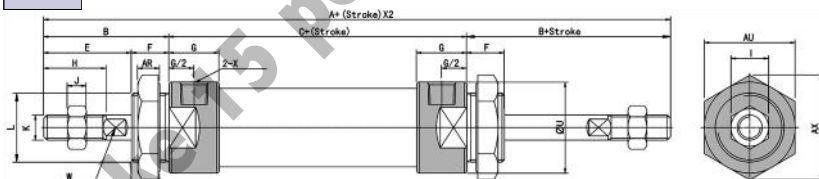

## MAJ

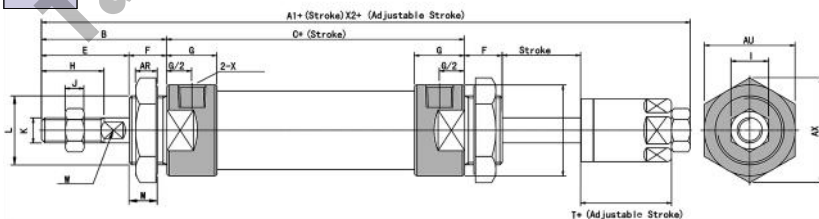

Bore	A	A1	B	C	E	F	G	H	I	J	K
20	156	153	40	70	28	12	16	20	12	6	M8 X 1.25
25	164	161	44	70	30	14	16	22	17	6	M10 X 1.25
32	164	161	44	70	30	14	16	22	17	6	M10 X 1.25
40	168	164	46	92	32	14	22	24	17	7	M12 X 1.25
Bore	L	M	U	V	W	X	AR	AX	AY	T	
20	M22 X 1.5	10	29	8	6	G1/8	7	33	29	19	
25	M22 X 1.5	12	34	10	8	G1/8	7	33	29	21	
32	M24 X 1.5	12	39.5	12	10	G1/8	8	37	32	21	
40	M30 X 2.0	12	49.5	16	14	G1/4	9	47	41	21	

# MAL Series Aluminum Round Cylinder Dimensions

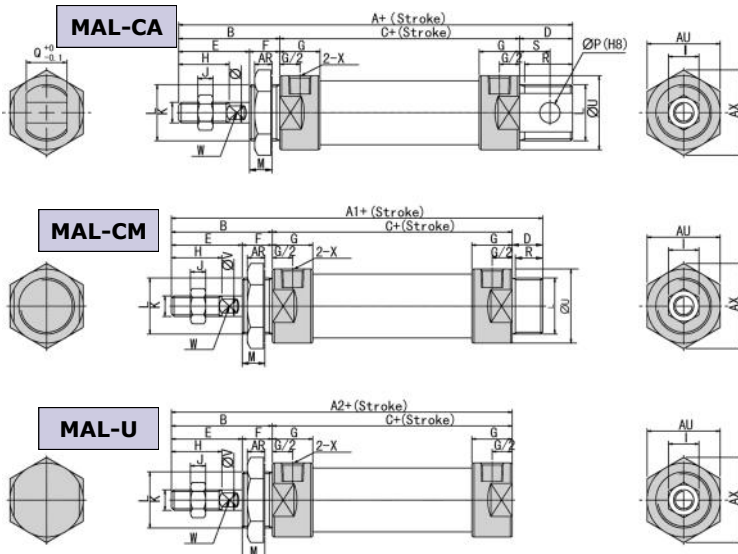

Bore	A	A1	A2	B	C	D	D1	E	F	G	H	I	J	K
16	104	104	90	38	52	15	15	24	14	11	16	10	5	M6 X 1
20	131	122	110	40	70	21	12	28	12	16	20	12	6	M8 X 1.25
25	135	128	114	44	70	21	14	30	14	16	22	17	6	M10 X 1.25
32	141	128	114	44	70	27	14	30	14	16	22	17	6	M10 X 1.25
40	165	152	138	46	92	27	14	32	14	22	24	17	7	M12 X 1.25
Bore	L	M	P	Q	R	R1	S	U	V	W	X	AR	AX	AY
16	M16 X 1.5	8	6	12	13	13	6	20	6	/	M5	7	24	28
20	M22 X 1.5	10	8	16	19	12	12	29	8	6	G1/8	7	33	29
25	M22 X 1.5	12	8	16	19	14	12	34	10	8	G1/8	7	33	29
32	M24 X 2.0	12	10	16	25	14	15	40	12	10	G1/8	8	37	32
40	M30 X 2.0	12	12	20	25	14	15	50	16	14	G1/4	9	47	41

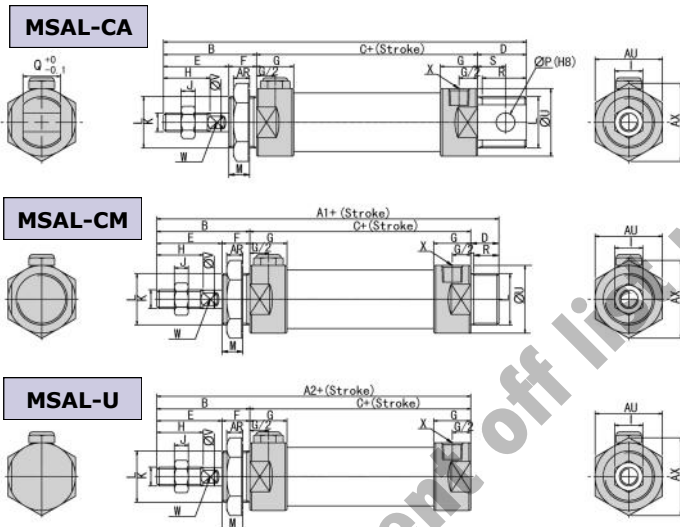

Symbol	A	A1	A2	B	C	D	D1	E	F	G	H	I
Bore	0-50	51-100	0-50	51-100	0-50	51-100	0-50	51-100	0-50	51-100	0-50	51-100
20	131	156	122	147	110	135	40	70	95	21	12	28
25	135	160	128	153	114	139	44	70	95	21	14	30
32	141	166	128	153	114	139	44	70	95	27	14	30
40	165	190	152	177	138	163	46	92	117	27	14	32

Bore	J	K	L	M	P	Q	R	R1	S	U	V	W	X	AR	AX	AY
20	6	M8 X 1.25	M22 X 1.5	10	8	16	19	12	12	29	8	6	G1/8	7	33	29
25	6	M10 X 1.25	M22 X 1.5	12	8	16	19	14	12	34	10	8	G1/8	7	33	29
32	6	M10 X 1.25	M24 X 2.0	12	10	16	25	14	15	39.5	12	10	G1/8	8	37	32
40	7	M12 X 1.25	M30 X 2.0	12	12	20	25	14	15	49.5	16	14	G1/4	9	47	41

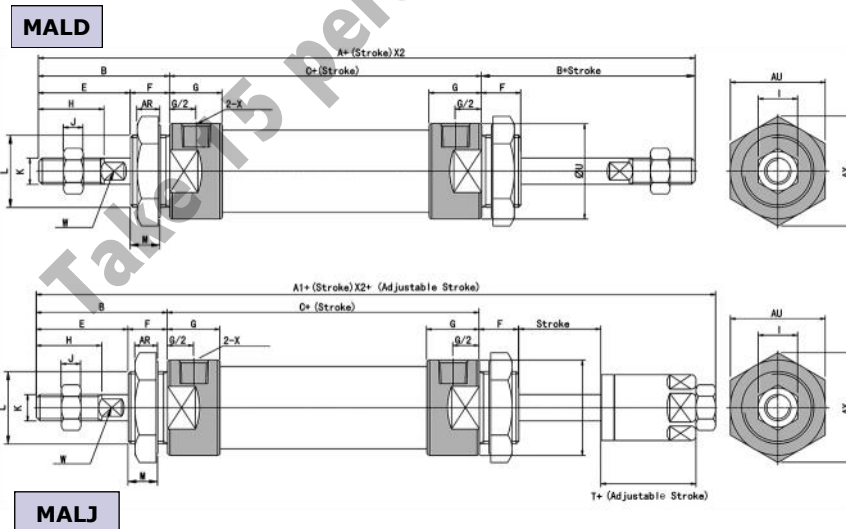

Bore	A	A1	B	C	E	F	G	H	I	J	K
20	131	122	40	70	28	12	16	20	12	6	M8 X 1.25
25	135	128	44	70	30	14	16	22	17	6	M10 X 1.25
32	141	128	44	70	30	14	16	22	17	6	M10 X 1.25
40	165	152	46	92	32	14	22	24	17	7	M12 X 1.25
Bore	L	M	U	V	W	X	AR	AX	AY	T	
20	M22 X 1.5	10	29	8	6	G1/8	7	33	29	19	
25	M22 X 1.5	12	34	10	8	G1/8	7	33	29	21	
32	M24 X 2.0	12	39.5	12	10	G1/8	8	37	32	21	
40	M30 X 2.0	12	49.5	16	14	G1/4	9	47	41	21	

# SC & SU Series Tie Rod Cylinder Dimensions | SDA Series Compact Cylinder Dimensions

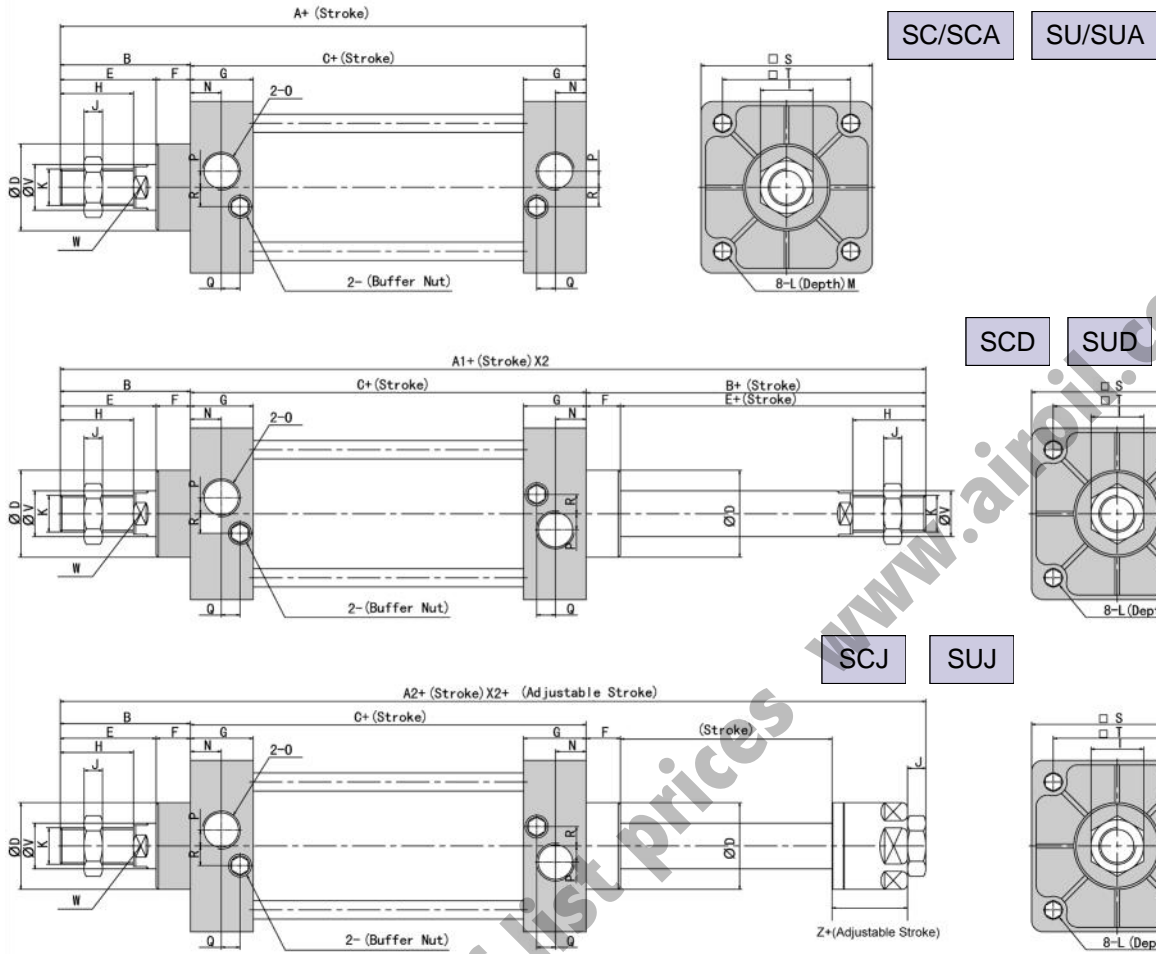

BORE	A	A1	A2	B	C	D	E	F	G	H	J	K	L	M	N	O	P	Q	R	S	T	V	W	Z	
32	140	187	182	47	93	28	32	15	27.5	22	17	6	M10X1.25	M6X1	9.5	13.5	1/8	3.5	7.5	7	45	33	12	12	21
40	142	191	185	48	93	32	34	15	27.5	24	17	7	M12X1.25	M6X1	9.5	13.5	1/4	6	8.2	9	50	37	16	14	21
50	150	207	196	57	93	38	42	15	27.5	32	23	8	M16X1.25	M6X1	9.5	13.5	1/4	8.5	8.2	9	62	47	20	17	23
63	153	210	199	57	96	38	42	15	27.5	32	23	8	M16X1.25	M8X1.25	9.5	13.5	3/8	7	8.2	8.5	75	56	20	17	23
80	183	258	243	75	108	47	54	21	33	40	26	10	M20X1.25	M10X1.5	11.5	16.5	3/8	10	9.5	14	94	70	25	22	29
100	189	264	249	75	114	47	54	21	33	40	26	10	M20X1.25	M10X1.5	11.5	16.5	1/2	11	9.5	14	112	84	25	22	29
125	226	/	/	104	122	55	70	34	33	54	40	10	M27X1.25	M12X1.75	15.5	16.5	1/2	/	/	/	140	110	32	27	/
160	291	/	/	123	168	62	91	32	50	72	55	18	M36X1.25	M16X2	17.5	25	1/2	/	/	/	180	140	40	36	/
200	347	/	/	167	180	80	112	55	50	72	55	18	M36X1.25	M16X2	17.5	25	3/4	/	/	/	220	175	40	36	/

MODEL: SDA12-16

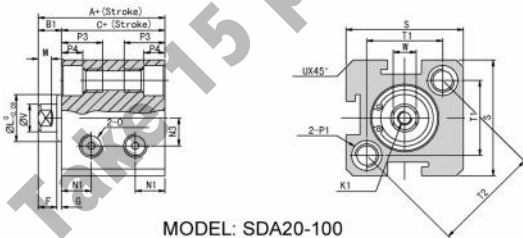

MODEL: SDA20-100

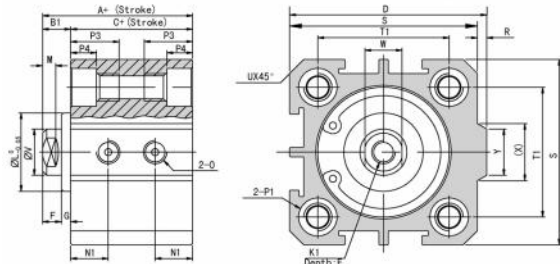

SDA Bore	Standard Type			With Magnet			D	E	F	G	K1	L
	A	B1	C	A	B1	C						
12	22	5	17	32	5	27	-	6	4	1	M3X0.5	10.2
16	24	5.5	18.5	34	5.5	28.5	-	6	4	1.5	M3X0.5	11
20	25	5.5	19.5	35	5.5	29.5	36	8	4	1.5	M4X0.7	16
25	27	6	21	37	6	34	42	10	4	2	M5X0.8	17
32	31.5	7	24.5	41.5	7	34.5	50	12	4	3	M6X1	22
40	33	7	26	43	7	36	58.5	12	4	3	M8X1.25	28
50	37	9	28	47	9	38	71.5	15	5	4	M10X1.5	38
63	41	9	32	51	9	42	84.5	15	5	4	M10X1.5	40
80	52	11	41	62	11	51	104	15	6	5	M14X1.5	45
100	63	12	51	73	12	61	124	18	7	5	M18X1.5	55

Bore	M	N1	N3	O	P1/DIA	P3	P4	R	S	T1	T2	U	V	W	X	Y
12	2.8	6.3	6	M5X0.8	M5X0.8X4.2	12	4.5	-	25	16.2	23	1.6	6	5	-	-
16	2.8	7.3	6.5	M5X0.8	M5X0.8X4.2	12	4.5	-	29	19.8	28	1.6	6	5	-	-
20	2.8	7.5	-	M5X0.8	M5X0.8X4.2	14	4.5	2	34	24	-	2.1	8	6	11.3	10
25	2.8	8	-	M5X0.8	M6X1.0X4.6	15	5.5	2	40	28	-	3.1	10	8	12	10
32	2.8	9	-	1/8	M6X1.0X4.6	16	5.5	6	44	34	-	2.15	12	10	18.3	15
40	2.8	10	-	1/8	M8X1.25X6.5	20	7.5	6.5	52	40	-	2.25	16	14	21.3	16
50	2.8	10.5	-	1/4	M8X1.25X6.5	25	8.5	9.5	62	48	-	4.15	20	17	30	20
63	2.8	11.8	-	1/4	M8X1.25X6.5	25	8.5	9.5	75	60	-	3.15	20	17	28.7	20
80	4	14.5	-	3/8	M12X1.75X9.2	25	10.5	10	94	74	-	3.65	25	22	36	26
100	4	20.5	-	3/8	M12X1.75X11.3	30	13	10	114	90	-	3.65	32	27	35	26





## Terms and Conditions

By purchasing from SIZTO TECH CORPORATION (STC), you agree to these TERMS AND CONDITIONS. No other terms shall apply except as agreed in writing signed by us. We reserve the right to correct typographic errors and reject orders.

### SHIPMENTS:

All shipments are F.O.B. 892 Commercial Street, Palo Alto, CA 94303, USA. Most orders are shipped via UPS Standard Ground unless instructions accompany order. Outside the UPS zones, shipment will be made Best Way. The responsibility for goods delay, lost or damaged in transit rests with the carrier and purchaser. Purchaser may purchase shipping insurance to cover lost or damaged products caused by shipping.

### RETURN OF MERCHANDISE:

No merchandise is accepted for return 30 days after delivery date. No credit allowed on merchandise shipped as ordered and returned without obtaining an authorization number IN ADVANCE. A 20% restocking charge applies to all returns, and transportation charges must be fully pre-paid. We will pay **ground** transportation charges on re-sent or returned merchandise due to STC's error.

**Shortages & Mis-Shipments:** Any shortages or mis-shipment must be reported within 15 days.

### CANCELLATION POLICY:

Blanket order can be canceled 90 days before scheduled ship date. There will be a 10% charge if a blanket order is cancel within 90 days of scheduled ship date, and a 20% charge if cancel within 60 days. Regular order for non-custom parts can be canceled any time before the order is shipped. For custom parts, a 30% down payment is required either at the time of order or 90 days prior to scheduled ship date, whichever comes later.

### Remittances should be sent to:

Sizto Tech Corporation, 892 Commercial Street, Palo Alto, CA 94303, USA

Credit Card Payments: Visa, MasterCard, Discover, or American Express Accepted

**International Customers:** Advance Payment Required via Bank Wire, Cashier's Check or Approved Credit Card.

**Credit Application:** To establish a net 30 day account, please mail or fax three trade references with complete mailing addresses and account numbers.

### LIMITED WARRANTY – IMPORTANT NOTICE TO PURCHASER:

Sizto Tech Corporation (STC) only warrants this product to be free from defects in materials and workmanship at the time of shipment. This limited warranty expires one year after delivery to the end-user. STC's entire obligation to the Purchaser for breach of this limited warranty shall be limited to replacement of the defective product or refund of the original purchase price of this product, at STC's option. Purchaser has thirty (30) days to return the goods after STC has agreed to accept the return. All freight charges on returned material shall be paid by the Purchaser. STC's limited warranty shall not apply, however, to the product that have been subjected to misuse, alteration, accident or negligence during handling or storage.

### DISCLAIMER OF IMPLIED WARRANTIES:

All implied warranties, which may arise by implication of law or application of course of dealing or usage of trade, including, but not limited to, implied warranties of merchantability or fitness for a particular purpose are expressly excluded. There are no warranties, which extend beyond the description of the faced hereof. The end user is solely responsible for the suitability and fitness of this product selected for a particular application.

### OBLIGATIONS

You warrant, represent and agree: (1) to comply with all laws; (2) that our sale and shipment of the product will not, by export thereof, your legal status or otherwise, cause us to violate any law; and (3) to indemnify us against any losses from a failure by you or a third party to comply with law or these terms and conditions, or from use of the product.

### SAFETY WARNING

**Failure or improper selection or improper use of the components and products described herein or related items can cause death, personal injury and/or property damage.** This document and other related information from STC provide products options for further investigation by users having the technical expertise. It is important that you analyze all aspects of your application and review the information concerning the component or product in the current catalog. Due to the variety of operation conditions and applications for these components or products, the user, through his own analysis and testing, is solely responsible for making the final selection, installation and maintenance of the products and assuring that all performance, safety and warning requirements of the application are met. All products set-ups and maintenance require the supervision of a qualified individual who is familiar with installation, inspection and testing through training or experience.

### IMPORTANT NOTICE:

The products described herein, including without limitation, product features, specifications, design, availability and pricing, are subject to change without notice. We continuously improve the products, and we reserve the right to change specifications without incurring any obligation to incorporate new factors in equipment previously sold.

## Distributed By



**Sizto Tech Corporation**

892 Commercial Street

Palo Alto, CA 94303 USA

Tel: 650-856 8833 | Fax: 650-856 8811

Email: Sales@StcValve.com; www.StcValve.com