



Actuator Group

TDRO-40 Panel Meter

4 DIGIT 0.56" OR 0.8" LEDs in a 1/8 DIN CASE



Large display option
0.8" red or green LED

An economical smart programmable meter relay with isolated 4 to 20 mA retransmission or control loop output capability for measurement and control applications in a 96x48mm case.

General Features

- Optional isolated 16 bit analog output. User or factory scalable to 4 to 20 mA, 0 to 20 mA or 0 to 10 V across any desired digital span from \pm one count to the full scale range of -1999 to 9999 (12000 counts).
- Auto-sensing AC/DC power supply. For voltages between **85-265 V AC / 95-370 V DC (PS1)** or 15-48 V AC / 10-72 V DC (PS2).
- 24 V DC excitation is available to power external transmitters and 5 or 10 V DC excitation is available for resistance bridge type sensors such as Load Cells and Pressure Transducers.
- Standard 4-digit LED with display range -1999 to 9999 (12000 counts).
- Four annunciator LEDs provide front panel alarm status indication for up to four setpoints.
- Two 10 Amp Form C and two 5 Amp Form A relays, or optionally four 5 Amp Form A relays are available.
- Automatic intelligent averaging smooths noisy signals, while providing a fast display response to real level changes.

Software Features

- Three-button programming from the front panel (UP, DOWN and PROGRAM buttons).
- Three front panel selectable ranges.
- Front panel selectable four-level brightness control of digital display, and setpoint LEDs.
- Four programmable setpoints.
- Relay activation can be selected to occur above (HI) or below (LO) each setpoint.
- Hysteresis setting for all four setpoints. Delay on make and delay on break for SP1 and SP2.
- Peak and Valley. View and Reset.

Specifications

- Input Specs:**Depends on Input signal conditioner
- A/D Converter:**14 bit single slope
- Accuracy:** \pm (0.05% of reading + 2 counts)
- Temp. Coeff.:**100 ppm/ $^{\circ}$ C (Typical)
- Warm up time:**2 minutes
- Conversion Rate:**5 conversions per second (Typical)
- Display:****4 digit 0.56" Red LED display (std)**,
0.56" or 0.8" Red, Green or Super
Bright Red (optn)
Range -1999 to 9999 counts.
- Polarity:**Assumed positive. Displays - negative
- Decimal Selection:**.....Front panel button selectable, X•X•X•X•
- Positive Overage:**..Top segments of digital display flash
- Negative Overage:** Bottom segments of digital display flash
- Relay Output:**Two 5 Amp Form A relays and two 10
Amp Form C, or 5 Amp form A relays.
- Analog Output:**Isolated 16 bit user scalable mA or V
AIC (mA out)4-20 mA @ 0 to 500 Ω max loop resistance
AIV (volts out)0-10 V DC @ 500 Ω or higher resistance
- Power Supply:**AC/DC Auto sensing wide range supply
PS1 (std)**85-265 VAC / 95-370 VDC @ 2.5W max 3.5W**
PS215-48 VAC / 10-72 VDC @ 2.5W max 3.5W
- Operating Temp.:**0 to 60 $^{\circ}$ C
- Storage Temp:**-20 $^{\circ}$ C to 70 $^{\circ}$ C.
- Relative Humidity:**95% (non condensing)
- Case Dimensions:**1/8 DIN, Bezel: 96x48 mm (3.78"x1.89")
Depth behind bezel: 117 mm (4.61")
Plus 11.8 mm (0.47") for Right-angled
connectors, or plus 20 mm (0.79") for
Straight-thru connector.
- Weight:**6.5 oz., 8.5 oz when packed



Front Panel Buttons

Program Button

The **P** button is used to move from one program step to the next. When pressed at the same time as the **↑** button, it initiates the **calibration mode**. When pressed at the same time as the **↓** button, it initiates the **setpoint setting mode**.

Up Button

When in the operational display, pressing the **↑** button alone, allows you to view and reset the Peak and Valley (Highest and Lowest Readings.)

When in the **calibration mode** or the **setpoint setting mode** the **↑** button is used to increase the value of the displayed parameter.

Down Button

When in the operational display, pressing the **↓** button alone, allows you to view, but not change, the setting of setpoint 1,2,3 & 4.

When in the **calibration mode** or the **setpoint setting mode** the **↓** button is used to decrease the value of the displayed parameter.

Glossary of Programming Symbols

To explain software programming procedures, logic diagrams are used to visually assist in following the programming steps. The following symbols are used to represent various functions and associated display elements of the meter:

Symbol	Explanation
	This symbol represents the OPERATIONAL DISPLAY.
	This is the PROGRAM button.
	This is the UP button.
	This is the DOWN button.
	When a button is shown, press and release it to go onto the next step in the direction indicated by the arrow. When two or more buttons are shown, each with an arrow, this indicates that there is a number of programming choices.
	When two buttons are shown side by side and enclosed by a dotted line, they must be pressed at the same time then released to go onto the next programming step.
	If the display is shown with XXXX it means the value displayed will be the previously set value. When a number is shown it indicates the initial factory default setting or a specific "example number".

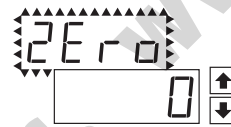

When two displays are shown together with bursts, this indicates that the display is toggling (flashing) between the name of the function and the value.

[Span]
[10000]

Text or numbers shown between square brackets in a procedure indicate the programming code name of the function or the value displayed on the meter display.



When the **↑** and **↓** buttons are shown together, the display value can be increased by pressing and releasing the **↑** button or decreased by pressing and releasing the **↓** button.

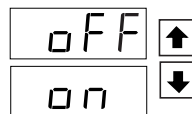

When the **↑** and **↓** buttons are shown with two displays, either display can be selected by pressing and releasing the **↑** or **↓** buttons.

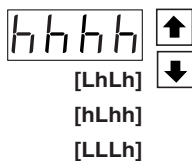

When there are more than two display selections they are shown in brackets below the first display and are also selectable by pressing and releasing the **↑** or **↓** buttons.

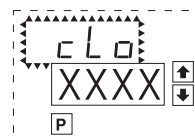

A dotted box indicates these functions are omitted or bypassed when the related hardware is not present

Software Logic Tree

The TDRO-40 is an intelligent meter with a hierarchical software structure designed for easy programming and operation, as shown below in the software logic tree.

After the meter has been powered up, the four digits light up for three seconds and then settle to the operational display indicating the input signal.

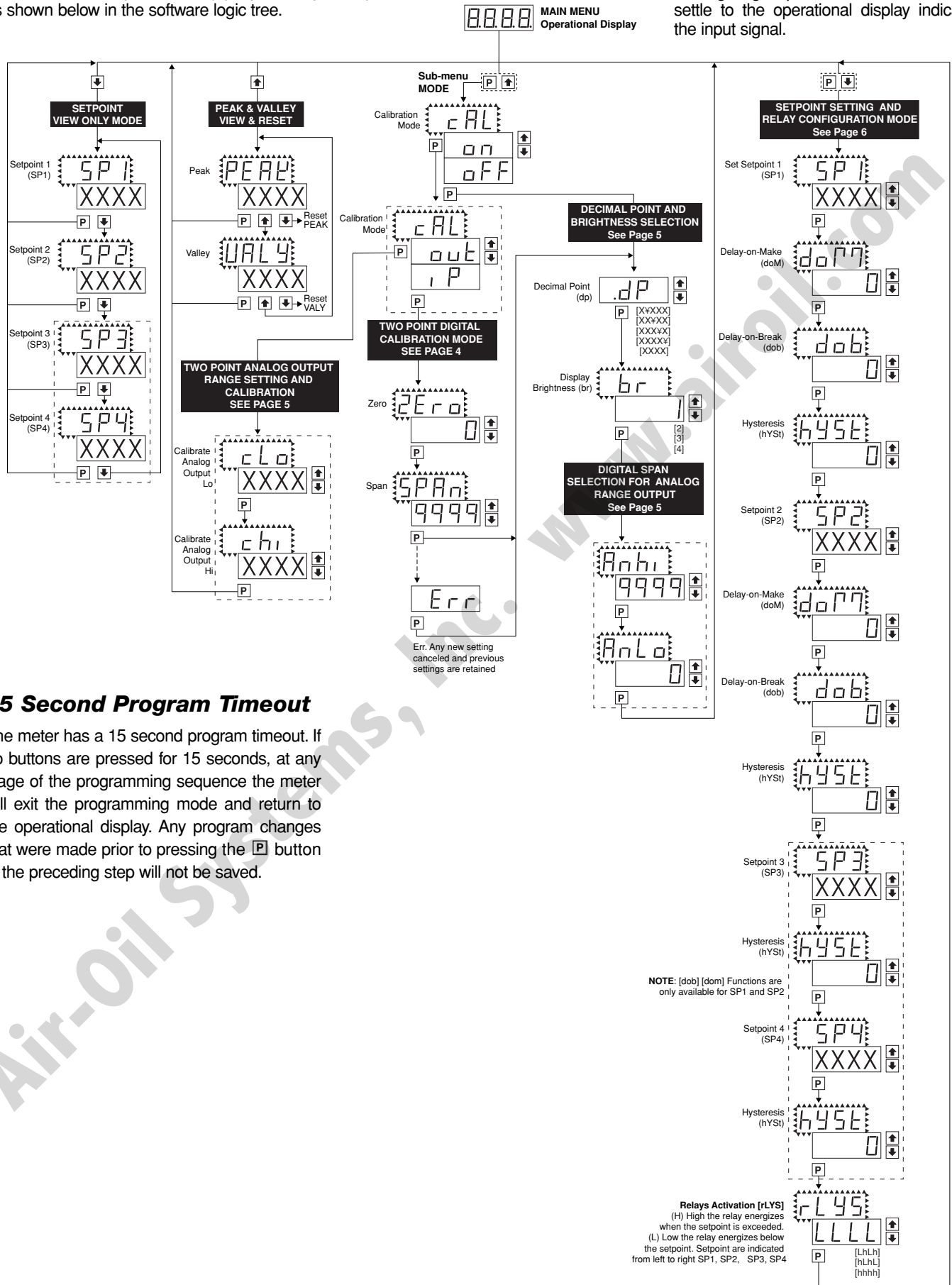

15 Second Program Timeout

The meter has a 15 second program timeout. If no buttons are pressed for 15 seconds, at any stage of the programming sequence the meter will exit the programming mode and return to the operational display. Any program changes that were made prior to pressing the **P** button in the preceding step will not be saved.

Air-Oil Systems

Digital Calibration Mode

This mode enables the meter to be calibrated with an automatic scale factor calculation, by applying a high input signal, entering the desired reading for that signal, then applying a zero or low input signal, and then entering the desired 0 or low reading. The meter then automatically calculates and programs in the requisite scale factor, within the following parameters.

1. Positive and negative signals may be applied, but the difference between the high and the low signal inputs must be at least 1000 counts or Err will be indicated.
2. Positive and Negative values for the desired reading can be entered, but the scale factor created can not exceed the Digital Display Span capability of the meter which is 12,000 counts between -1999 to 9999.
3. The internal Signal Span is limited to 3 V DC between -1 V DC to +2 V DC. Any outputs from an Input Signal Conditioning module that exceed these limits will cause the meter to indicate overrange regardless of the Digital Display Span scaled.

Note: Most input signal conditioners have provisions for analog calibration and scaling. If the meter's digital scale factor is set to read zero with a zero input (shorted input), and to read 1000 with a 1.000 V input, any pre-calibrated signal conditioner with an output that does not exceed -1 V to +2 V, will read correctly in the meter without any further calibration.

Digital Calibration Procedure

STEP A Enter the Calibration Mode

- 1) Press the and buttons at the same time. Display toggles between [cAL] and [oFF].
- 2) Press the or button. Display changes from [oFF] to [on].
- 3) Press the button. Display toggles between [ZEro] and the previous zero setting.

STEP B Select Between Two Point Digital Calibration of Input Signal and Two Point Analog Output

Note: If the analog output option is not present, Step B is skipped and the program goes directly from Step A to Step C.

- 1) Press the or button to select the display toggling from [cAL] to [iP] input calibration.
- 2) Press the button. Display toggles between [ZEro] and the previous zero setting.

STEP C Set the Meter's Low Input Signal Reading on the Digital Display

- 1) Apply a zero or low signal to the meter. (Positive or negative values are allowed)
- 2) Using the and buttons, adjust the meter display to the desired reading for the applied low input signal.
- 3) Press the button. Display toggles between [SPAN] and the previous span setting.

STEP D Set the Meter's High Input Signal Reading on the Digital Display

- 1) Apply a high input signal to the meter.
- 2) Using the and buttons, adjust the digital display to the desired reading for the applied high input signal.
- 3) Press the button.

The Digital Calibration Procedure Mode is Now Complete.

If the digital calibration was successfully completed, the menu branches to the DISPLAY FUNCTION CONFIGURATION MODE, (see page 7) and the display flashes [dP] and the previous setting.

ERROR Indicates Unsuccessful Calibration

If the calibration was unsuccessful, the display indicates [Err], the new calibration settings just entered will not take effect and the previously stored setting will remain.

The three most likely causes of an error during calibration are:

- 1) The full scale and zero signals were too similar. The full scale signal must be at least 1000 counts greater than the zero or low input signal (positive and negative values are allowed).
- 2) The scaling requirement exceeded the capability of the meter (-1999 to 9999).
- 3) No input signal present, or incorrect connections.

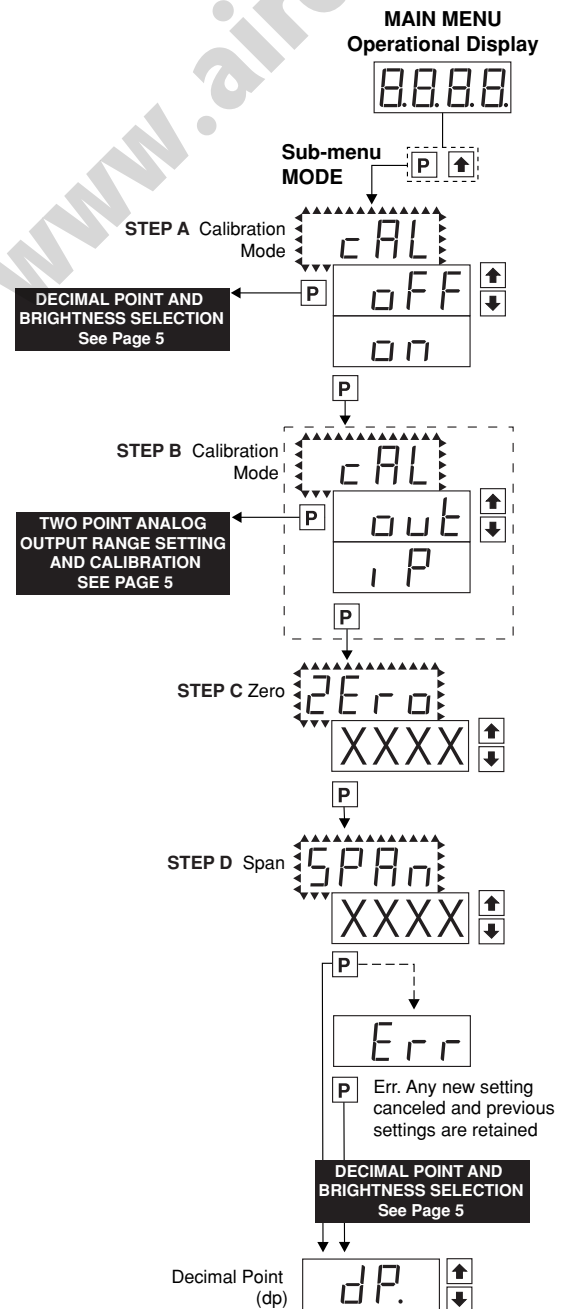

Two Point Analog Output Range Setting and Calibration

STEP A Enter the Calibration Mode

- 1) Press the **[P]** and **[↑]** buttons at the same time. Display toggles between [cAL] and [oFF].
- 2) Press the **[↑]** or **[↓]** button. Display changes from [oFF] to [on].
- 3) Press the **[P]** button. Display toggles between [cAL] and [out] input calibration.

Note: If at this point the display skips directly to toggle between [SPAn] and the previous [SPAn], the software is detecting that the optional analog output hardware is NOT installed.

STEP B Enter the Analog [oUT] Output Mode

- 1) Press the **[P]** button. Display toggles between [cLo] and an internal scale factor.

STEP C Set or Calibrate the [cLo] Low Analog Output Range

- 1) Select the voltage or current loop output header position on the output module. (See Component Layout on page 9).
- 2) Connect a multimeter to pins 16 and 17 on the output module. (See Rear Panel Pinouts on page 8). Using the **[↑]** and **[↓]** buttons, adjust the analog output to the desired low value as shown on the multimeter display. cLo may be adjusted to any value from -0.3 mA to 17 mA (mA output selected) or from -0.6 V to 8 V (volt output selected)
- 3) Press the **[P]** button. Display toggles between [chi] and an internal scale factor.

STEP D Set or Calibrate the [chi] High Analog Output Range

- 1) Using the **[↑]** and **[↓]** buttons, adjust the analog output to the desired high value as shown on the multimeter display. chi may be adjusted to any value from 17 mA to 21 mA (mA output selected) or from 8 V to 10.3 V (volt output selected)
- 2) Press the **[P]** button. The display exits the calibration mode and returns to the operational display.

Note: Having established the Low and High range of the analog output, the digital span can now be selected which will set the two digital points between which the analog output will occur. (See Digital Span Selection below).

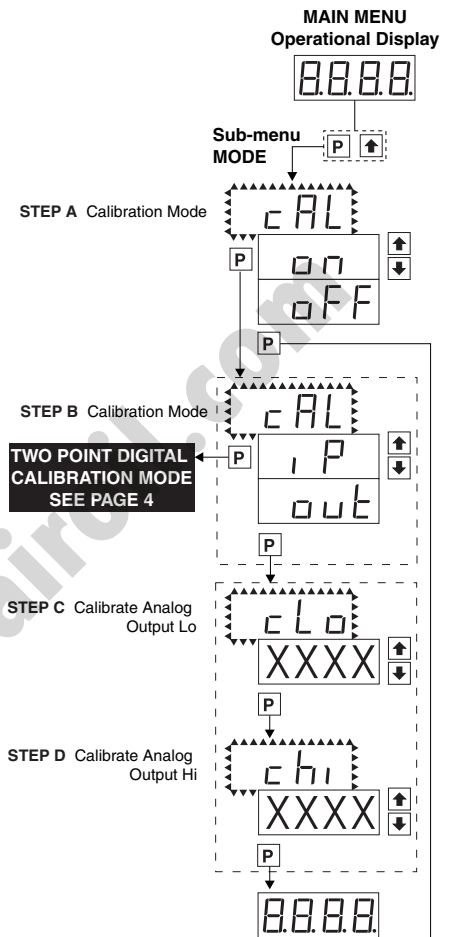

Decimal Point and Brightness Selection

Enter the Decimal Point and Brightness Mode Through the Sub Menu [CAL] [oFF]

- 1) Press the **[P]** and **[↑]** buttons at the same time. Display toggles between [cAL] and [oFF].
- 2) Press the **[P]** button. Display shows previous [dp] selection.

STEP E Set the Decimal Point

- 1) Using the **[↑]** and **[↓]**, adjust the display to the desired decimal point setting.
- 2) Press the **[P]** button. Display toggles between [Br] and the previous [Br] setting.

STEP F Set the Display Brightness

- 1) Using the **[↑]** and **[↓]** buttons, adjust the display to the desired brightness setting (4 is the brightest setting).
- 2) Press the **[P]** button. Display brightness changes to new setting and display toggles between [Anhi] and the previous [Anhi] setting.

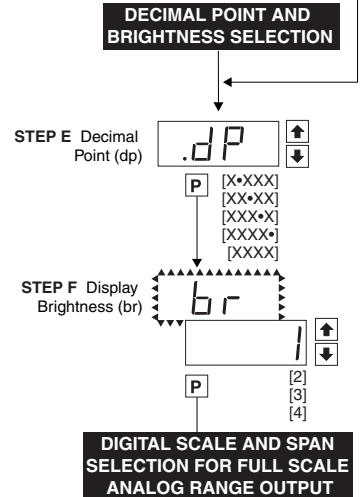

Digital Span Selection for Analog Range Output

STEP G Setting the Digital Span Point for Analog High Output

- 1) Using the **[↑]** and **[↓]** buttons, adjust the display to the desired digital value which sets the point at which the selected analog high output range will occur.
- 2) Press the **[P]** button. Display toggles between [AnLo] and previous [AnLo] setting.

STEP H Setting the Digital Span Point for Analog Low Output

- 1) Using the **[↑]** and **[↓]** buttons, adjust the display to the desired digital value which sets the point at which the selected analog low output range will occur.
- 2) Press the **[P]** button. The display exits the calibration mode and returns to the operational display.

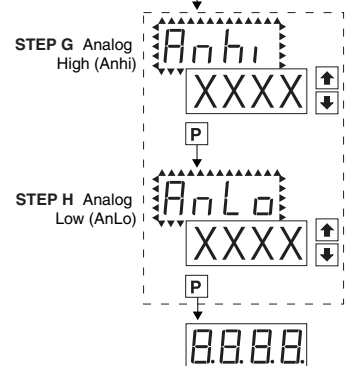

Note: Any two digital scale points from -1999 to 9999 can be selected. The digital scale points for analog high and analog low can be reversed for reversed 20-4 mA output. The span of the digital scale can be as small as two counts however small spans cause the 16 bit D to A to increment in stair case steps.

Setpoint Setting and Relay Configuration Mode

The following programming steps are required to enter the setpoint values and configure the relay functions in a meter with four relays using four setpoints. Generally if less than four relays are installed the software auto detects missing relays and deletes reference to them from the menu. In some cases setpoints without relays are operational for display only purposes.

STEP A Enter the Setpoint Mode

- 1) Press the **P** and **↓** buttons at the same time.
Display toggles between [SP1] and the previous [SP1] setting.

STEP B Set Setpoint 1 (SP1)

- 1) Using the **↑** and **↓** buttons, adjust the display to the desired SP1 value.
- 2) Press the **P** button. Display toggles between [doM] and the previous [doM] setting.

STEP C Set the SP1 Delay-on-Make (doM) Delay Time Setting

- 1) Using the **↑** and **↓** buttons, adjust the display to the desired [doM] value (0 to 9999 seconds). The reading must continuously remain in an alarm condition until this delay time has elapsed before the relay will make contact (energize).
- 2) Press the **P** button. Display toggles between [dob] and the previous [dob] setting.

STEP D Set the SP1 Delay-on-Break (dob) Delay Time Setting

- 1) Using the **↑** and **↓** buttons, adjust the display to the desired [dob] value (0 to 9999 seconds). The reading must continuously remain in an alarm condition until this delay time has elapsed before the relay will break contact (de-energize).
- 2) Press the **P** button. Display toggles between [hYSt] and the previous [hYSt] setting.

STEP E Set the Hysteresis Setting for Setpoint 1

- 1) Using the **↑** and **↓** buttons, adjust the display to the desired hysteresis [hYSt] value.
 - 2) Press the **P** button. Display toggles between [SP2] and the previous [SP2] setting.
- NOTE:** Half of the Hysteresis value selected is applied above and below the setpoint.

NOTE: Steps F, G, H and J have functionally the same procedure as steps B, C, D, and E shown above.

STEP F Set Setpoint 2 (SP2)

STEP G Set the SP2 Delay-on-Make (doM) Delay Time Setting

STEP H Set the SP2 Delay-on-Break (dob) Delay Time Setting

STEP I Set the Hysteresis Setting for Setpoint 2

- 1) Using the **↑** and **↓** buttons, adjust the display to the desired hysteresis [hYSt] value.
- 2) Press the **P** button. Display toggles between [SP3] and the previous [SP4] setting.

STEP J Set Setpoint 3 (SP3) (No [doM] or [dob])

- 1) Using the **↑** and **↓** buttons, adjust the display to the desired SP3 value.
- 2) Press the **P** button. Display toggles between [hYSt] and the previous [hYSt] setting.

STEP K Set the Hysteresis Setting for Setpoint 3

- 1) Using the **↑** and **↓** buttons, adjust the display to the desired hysteresis [hYSt] value.
- 2) Press the **P** button. Display toggles between [SP4] and the previous [SP4] setting.

STEP L Set Setpoint 4 (SP4) (No [doM] or [dob])

- 1) Using the **↑** and **↓** buttons, adjust the display to the desired SP4 value.
- 2) Press the **P** button. Display toggles between [hYSt] and 0.

STEP M Set the Hysteresis Setting for Setpoint 4

- 1) Using the **↑** and **↓** buttons, adjust the display to the desired hysteresis [hYSt] value.
- 2) Press the **P** button. Display toggles between [rLYS] and the previous relay setting.

STEP N Set Relay Activation mode [rLYS]

(h) High the relay energizes when the setpoint is exceeded. (L) Low the relay energizes below the setpoint. The setpoint is indicated from left to right SP1, SP2, SP3, SP4.

- 1) Using the **↑** and **↓** buttons, adjust the reading on the display to the desired relay settings: [LLLL], [LhLh], [LLhh], [hhhh].
If only 2 relays installed [Lh] hL] [hh] [LL].
- 2) Press the **P** button.
The meter exits the setpoint mode and returns to the operational display.

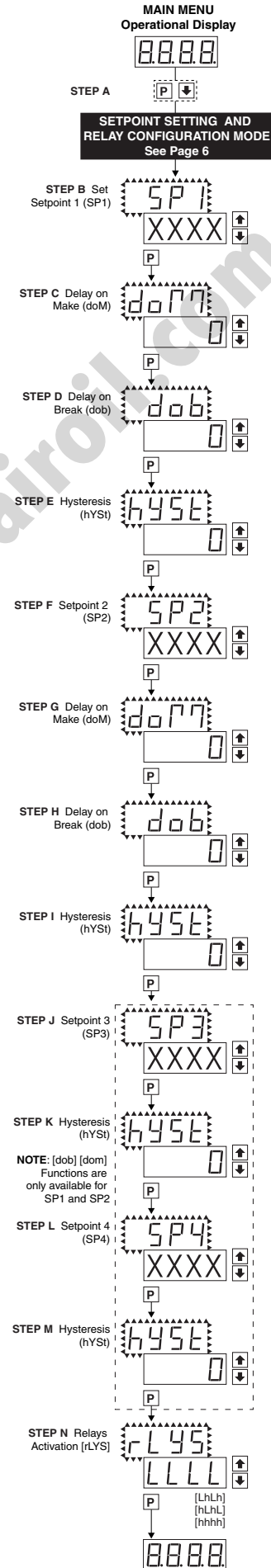

The Setpoint Relay programming mode is now complete.

Functional Diagram

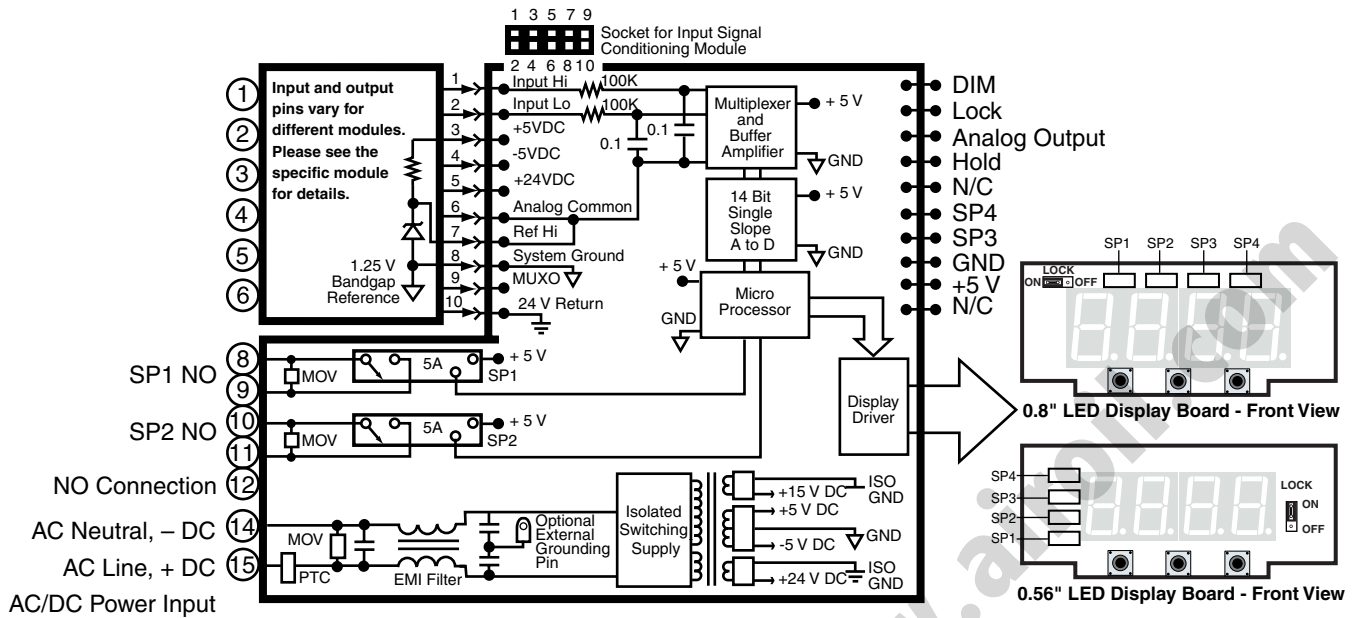

OPTIONAL TOP BOARD

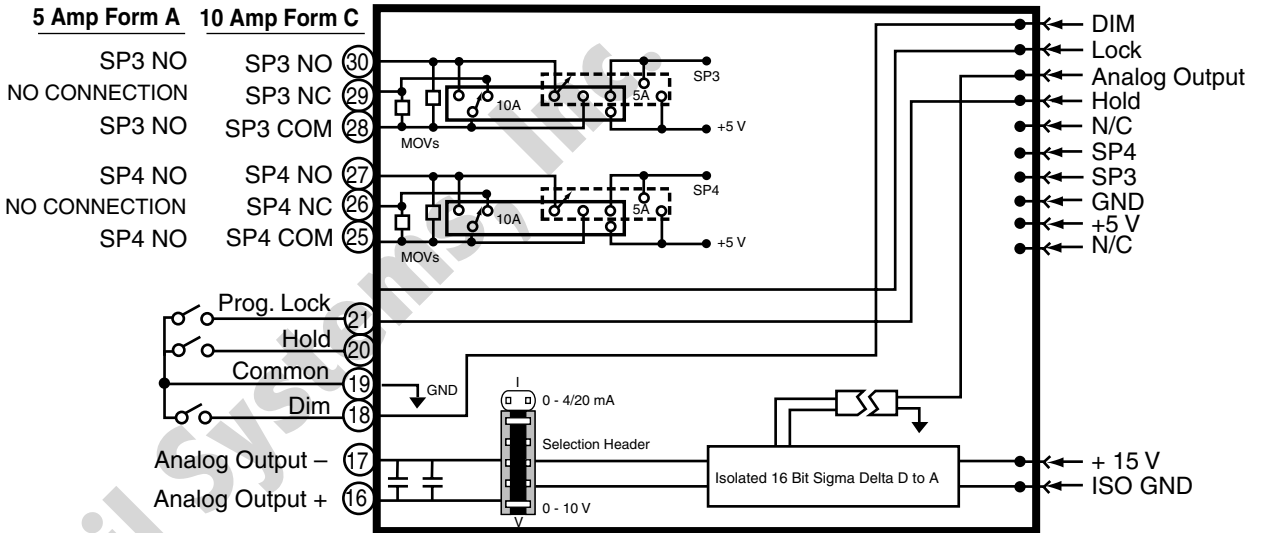

Pinout Diagram

The Rear View of the Meter diagram shows the meter with the relay configuration: dual 10 Amp Form C and dual 5 Amp Form A relays. An analog output module is also shown as installed.

The TDRO-40 uses plug-in type screw terminal connectors for all input and output connections. The power supply connections (pins 14 and 15) have a unique plug and socket outline to prevent cross connection. The main board and input signal conditioner use right-angled connectors as standard. The output module uses straight-thru connectors as standard.

Replacement 2-, 3-, and 4-pin plug connectors are available (see Accessories on page 16).

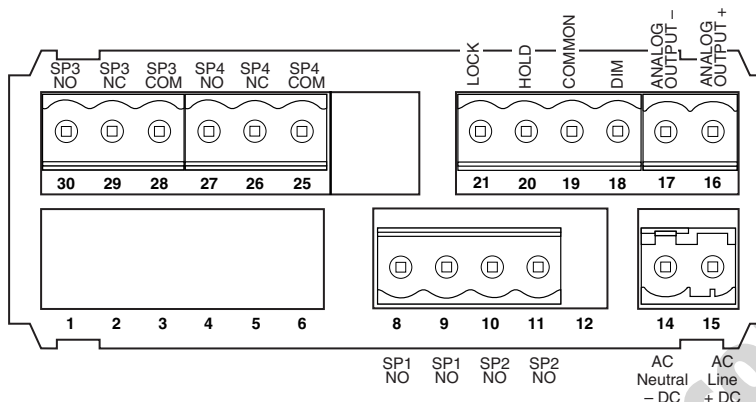

Auto-sensing AC/DC power supply. For voltages between 85-265 V AC / 95-370 V DC (PS1) or 18-48 V AC / 10-72 V DC (PS2).

Connectors



WARNING

AC and DC input signals and power supply voltages can be hazardous. Do not connect live wires to screw terminal plugs, and do not insert, remove or handle screw terminal plugs with live wires connected.

Standard plug-in screw terminal connectors provided by Numatics:

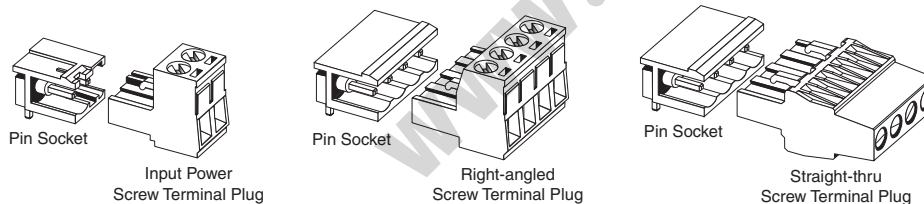

Pin Descriptions

Input Signal – Pins 1 to 6

Pins 1 to 6 are reserved for the input signal conditioner. See the data sheet for the selected input signal conditioner.

Pins 8 to 12 – Relay Output Pins

- Pin 8 SP1 NO. Normally Open 5 Amp Form A.
- Pin 9 SP1 NO. Normally Open 5 Amp Form A.
- Pin 10 SP2 NO. Normally Open 5 Amp Form A.
- Pin 11 SP2 NO. Normally Open 5 Amp Form A.
- Pin 12 NO CONNECTION.

Pins 14 and 15 – AC/DC Power Input

Auto-sensing AC/DC power supply. For voltages between 85-265 V AC/95-370 V DC (PS1) or 18-48 V AC/10-72 V DC (PS2).

- Pin 14 AC/DC Neutral. Neutral power supply line.
- Pin 15 AC/DC line. Live power supply line.

Optional Top Board Pins

Pins 16 and 17 – Analog Output

Pins 16 and 17 are the analog output pins on the optional output module. Their pin definitions are:

- Pin 16 Positive (+) analog output.
- Pin 17 Negative (-) analog output.

Pins 18 to 21 – Rear Panel Function Pins

Pins 18 to 21 provide functions that can be implemented with an external switch. Their pin definitions are:

- Pin 18 DIM. By connecting the display dim (DIM) pin to the COMMON pin, the display brightness setting is halved.
- Pin 19 COMMON. To activate the LOCK or DIM functions from the rear of the meter, the respective pins have to be connected to the COMMON pin. This pin is connected to the internal power supply ground.
- Pin 20 HOLD. By connecting the HOLD pin to the COMMON pin, the displayed reading is frozen, however, A/D conversions continue. When the HOLD pin is disconnected from the COMMON pin, the correct reading is displayed.
- Pin 21 LOCK. By connecting the LOCK pin to the COMMON pin, the meter's programmed parameters can be viewed but not changed.

Pins 25 to 30 – Top Board Relay Output Pins

The top board also supports the secondary relays. These can be either two 5 Amp Form A relays, two 10 Amp Form C relays, or a combination of both types.

		10 Amp Form C	5 Amp Form A
Pin 25	SP4	Common	Normally Open
Pin 26	SP4	Normally Closed	No Connection
Pin 27	SP4	Normally Open	Normally Open
Pin 28	SP3	Common	Normally Open
Pin 29	SP3	Normally Closed	No Connection
Pin 30	SP3	Normally Open	Normally Open

Display Board – Rear View

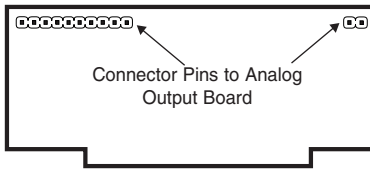

Display Board – Front View



0.56" LED Display Board - Front View

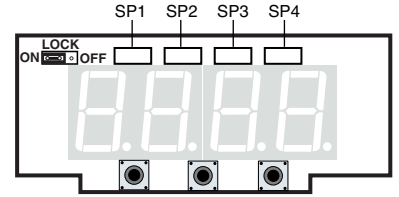

0.8" LED Display Board - Front View

PS1 High Volt Main Board
With Typical Input Signal Conditioner

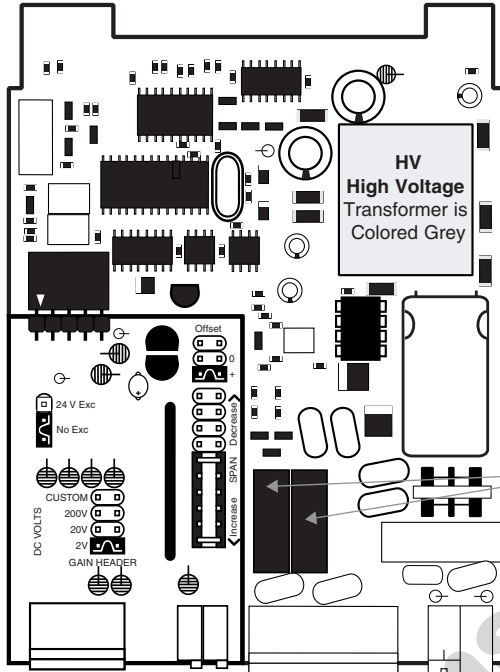

PS2 Low Volt Main Board
With Typical Input Signal Conditioner

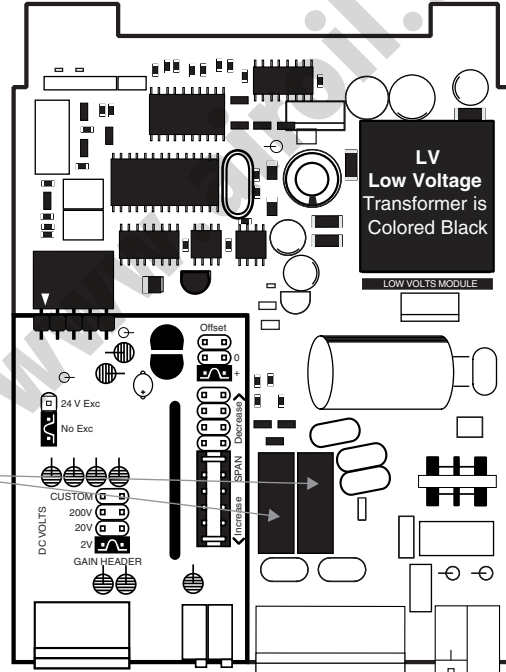

Primary Relays
Two Optional 5 Amp
Form A

Analog Output Board – Viewed From Bottom

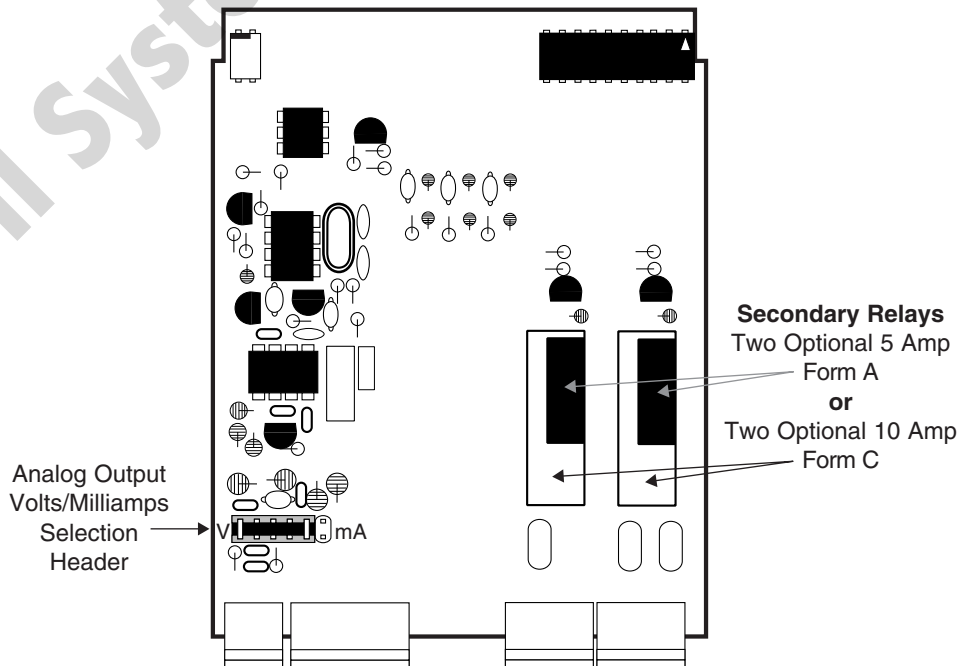

IR03: Linear Potentiometer 1KΩ min

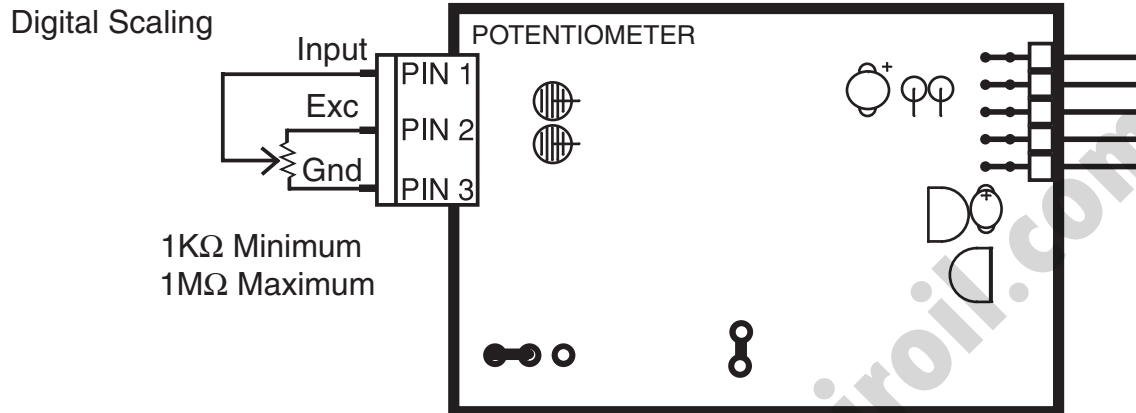

Stackable Cases

Mosaic and Stacked Array 1/8 DIN 96x48 mm (3.78"x1.89") Stack Mounting Case

International DIN cases are particularly suited for mounting individually or in stacked arrays in mosaic panels or thick insulative panels.

96x48 mm case can mount in thin panels or panels up to 50 mm (2.0") thick. They can also stack mount, 2 up in existing cutouts for 1/4 DIN (96x96 mm) or 4 up in 1/2 DIN (96x192 mm).

For additional strength, extra Mounting Slide Clips can be ordered & doubled up one behind the other. (P/N: 75-DMTCLIPF).

When extra panel mounting tightness is required, optional Screw Mounting Clips are included which fit on the Mounting Slide Clips. (P/N: OP-MTLCLIP).

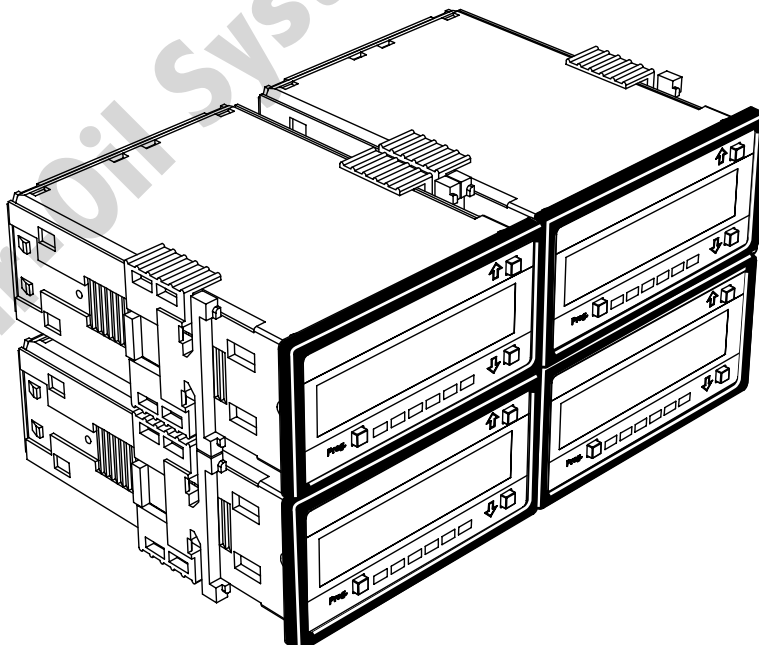

1/8 DIN 96x48 mm (3.78"x1.89")

Metal Surround Case OP-MTL96X48

The meter's plastic case is made from fire retardant polycarbonate. A metal surround case can be ordered to enhance the meter's fire retardant capabilities and also provide shielding against electromagnetic interference (EMI). The metal case slides over the polycarbonate case and is held firmly in place by spring-type non-return clips. Once the metal case has been fitted to the polycarbonate case it cannot be removed.

With the metal case in place, the meter's plastic ratchet-type mounting clips can no longer be used. A pair of screw-type mounting clips are inserted into holes on the side of the metal case and used to mount the meter in the panel. A ground tab on the metal case provides a ground connection between the meter's main board and the metal case.

* Metal Surround Case must be factory installed.

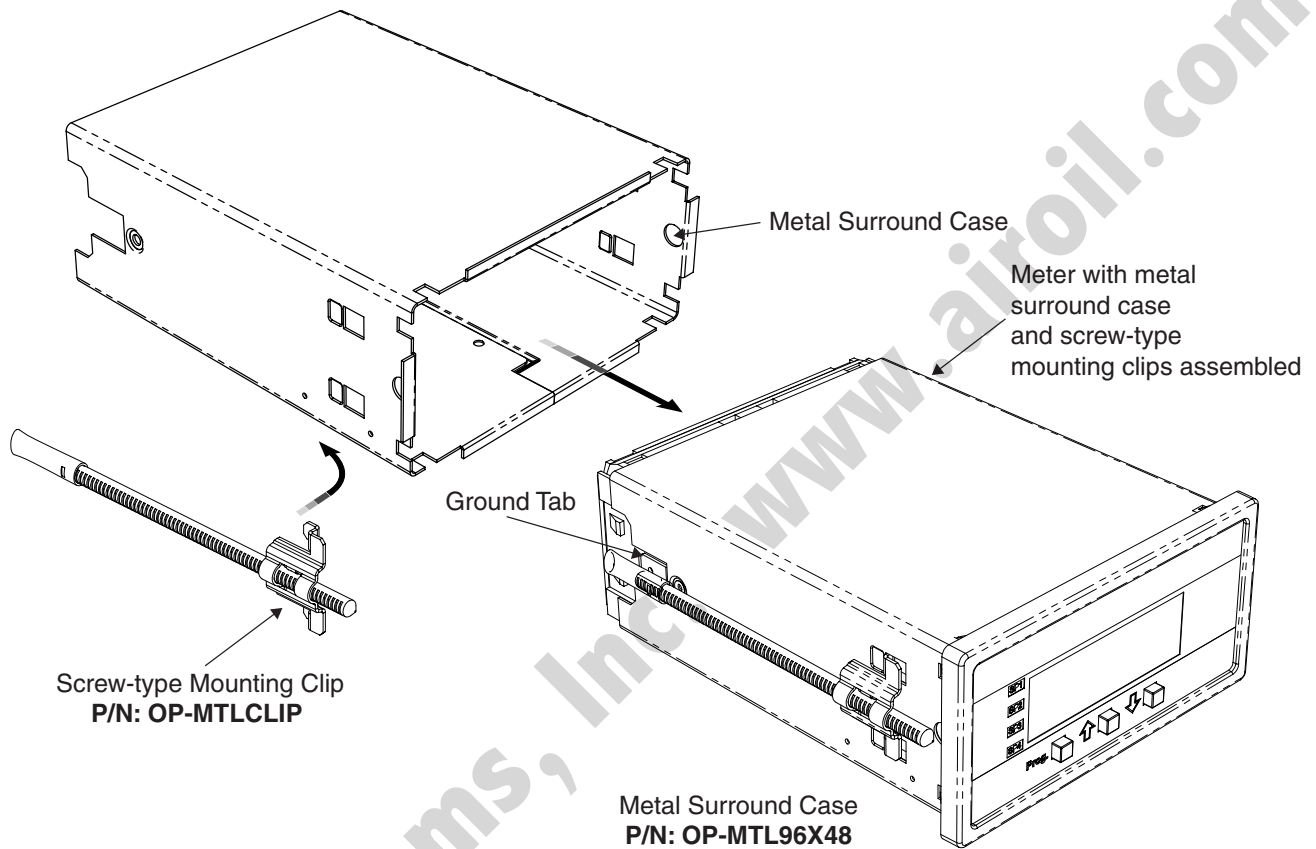

Lens Cover OP-N4X/96X48

The lens cover is designed to be dust and water proof to NEMA-4 standards. The lens cover consists of a base and cover with a cam hinge and key-lock locking device.

An O-ring, or neoprene gasket forms a seal between the base and the panel. The cam hinge prevents the cover from closing when opened until pushed closed. The cover has a tapered recess that, when closed, forms a capillary seal with a tapered ridge on the base. Turning the key-lock tightens the cover to the base, ensuring seal integrity. A safety catch keeps the cover closed even when the key is turned to the open position and removed. The keyhole can also be used to attach a safety seal clip, preventing unauthorized opening.

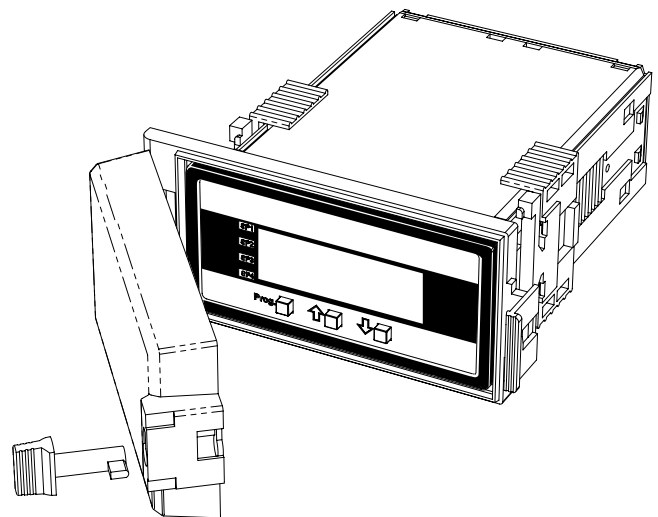

Case Dimensions

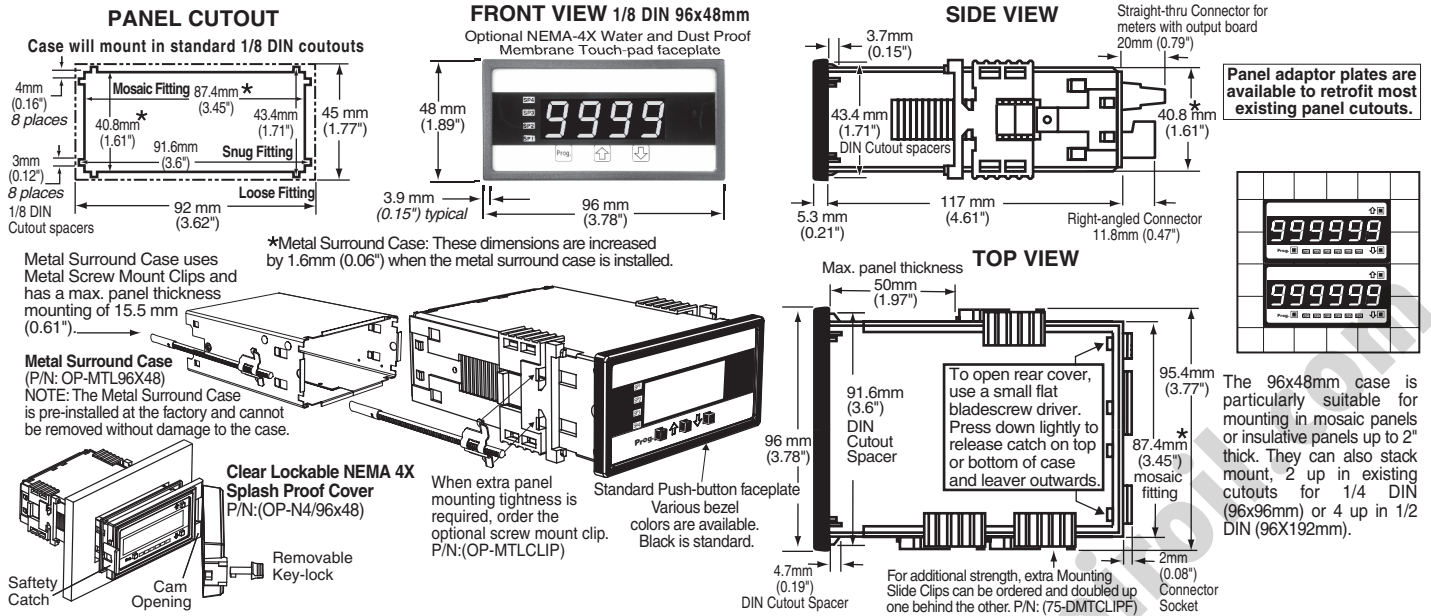

NEMA-4X Panel to Case Seal Adapters

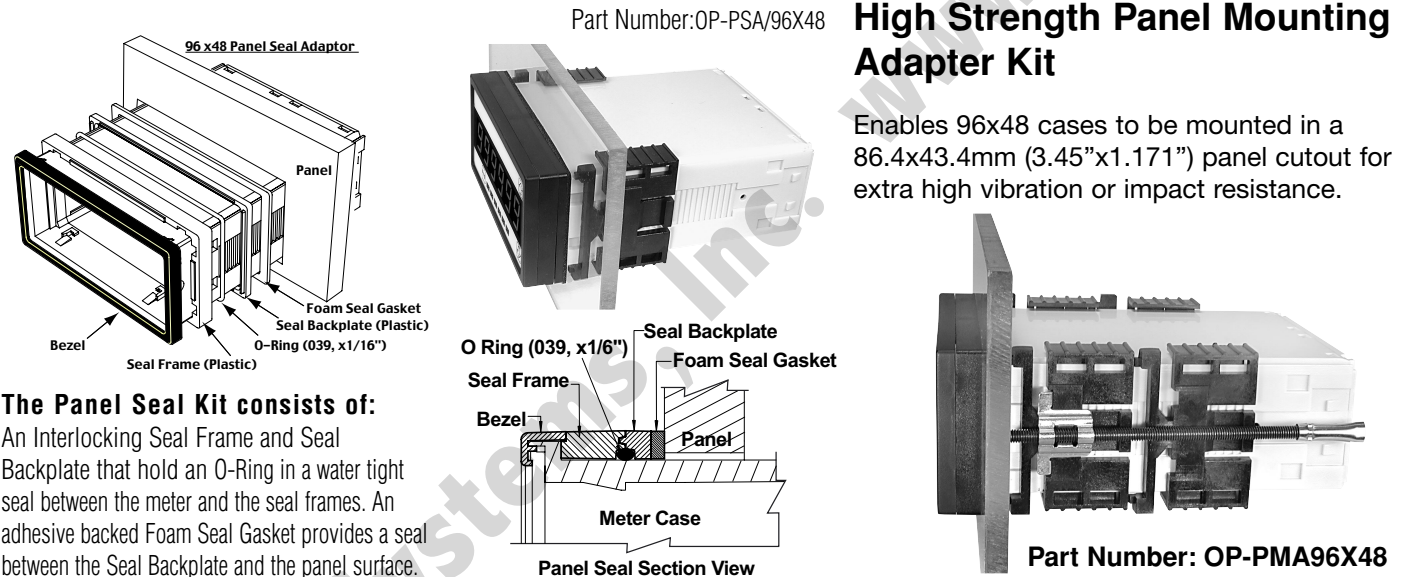

The Panel Seal Kit consists of:

An Interlocking Seal Frame and Seal Backplate that hold an O-Ring in a water tight seal between the meter and the seal frames. An adhesive backed Foam Seal Gasket provides a seal between the Seal Backplate and the panel surface.

WARRANTY

The supplier warrants that its products are free from defects in material and workmanship under normal use and service for a period of one year from date of shipment. The supplier's obligations under this warranty are limited to replacement or repair, at its option, at its factory, of any of the products which shall, within the applicable period after shipment, be returned to The supplier's facility, transportation charges pre-paid, and which are, after examination, disclosed to the satisfaction of The supplier to be thus defective. The warranty shall not apply to any equipment which shall have been repaired or altered, except by The supplier, or which shall have been subjected to misuse, negligence, or accident. In no case shall The supplier's liability exceed the original purchase price. The aforementioned provisions do not extend the original warranty period of any product which has been either repaired or replaced by The supplier.

USER'S RESPONSIBILITY

We are pleased to offer suggestions on the use of our various products either by way of printed matter or through direct contact with our sales/application engineering staff. However, since we have no control over the use of our products once they are shipped, NO WARRANTY WHETHER OF MERCHANTABILITY, FITNESS FOR PURPOSE, OR OTHERWISE is made beyond the repair, replacement, or refund of purchase price at the sole discretion of The supplier. Users shall determine the suitability of the product for the intended application before using, and the users assume all risk and liability whatsoever in connection therewith, regardless of any of our suggestions or statements as to application or construction. In no event shall The supplier's liability, in law or otherwise, be in excess of the purchase price of the product.

The supplier cannot assume responsibility for any circuitry described. No circuit patent licenses are implied. The supplier reserves the right to change circuitry, specifications, and prices without notice at any time.

Local Distributor Address:

