

APPLICATION BENEFITS

- High precision with straightness and flatness within 0.0002 inches per inch
- Superior rigidity with high moment loads
- Lowest deflection rate of any Tol-O-Matic actuator
- Excellent repeatability
- Wide stable platform for XY applications

GUIDANCE SYSTEM



- Ground linear profiled rails and ball bearing blocks decrease deflection and provide smooth carrier/load movement

STANDARD MOUNTING



- Mounting holes are spaced the length of the actuator for ease in mounting directly to a flat surface.

ACTUATOR/MOTOR FACTORS

- Actuator's operating temperature range (40-130° F, 4-54° C) should take into consideration heat generated by the motor and drive, linear velocity and work cycle time.
- For large frame motors or small actuators, cantilevered motors need to be supported, if subjected to continuous rapid reversing duty and/or under dynamic conditions.

AVAILABLE OPTIONS



Mounting Plates: provide clearance height for motors and motor mounts when mounting on a flush surface. Recommended on all TruTrack actuators, they prevent actuator body deflections over 0.015 in (3.8mm).



Auxiliary Carrier: Increases rigidity, load-carrying capacity and bending moments



Double C-face Brake: a power-off holding brake with an output shaft.

Double C-Face brakes are used for static holding (back driving prevention) and are not designed for dynamic stopping. If your application requires stopping, please contact Tol-O-Matic.



Bellows: protects from dust and dirt environments.



Motor Mounting and Gearhead Reduction:

In-line Motor Mounting— motor is internally coupled to the actuator shaft.



Reverse-parallel Motor Mounting—These factory assembled configurations allow offset mounting of the motor to either side of, or below the actuator. Available in 1:1 or 2:1 drive ratios, they offer quiet, zero-backlash coupling of the motor to the actuator screw shaft.



Gearhead Reduction—Gearheads are available for applications requiring reduction for inertia matching or higher torque at lower speeds. High efficiency, single stage, true planetary gearheads are available in 5.5:1 and 10:1 ratios for reduction solutions with most Tol-O-Matic NEMA 23- and 34-frame motors. For gearhead specifications and dimensions, see page F-10.



Switches: Available in ac reed or dc Hall-effect. (Triac switches are not available on TruTrack actuators) See section I.



RODLESS

TKS Series

- Application benefits
- Bearing system
- Standard mounting
- Actuator/motor factors
- Available options

TRUtrack™ TKS Screw Drives

ACME AND BALL SCREW/NUT COMBINATIONS

TKS ENGLISH ACME AND BALL SCREW CRITICAL SPEED CAPACITIES

CRITICAL SPEED WITH ENGLISH ACME SCREW

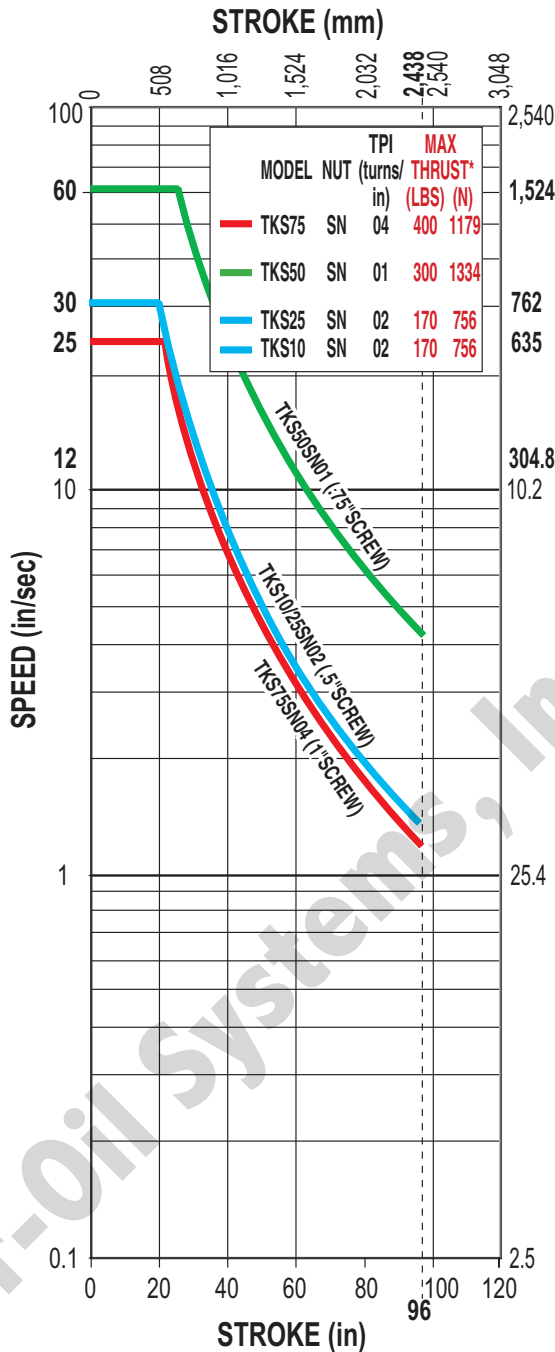

CRITICAL SPEED WITH ENGLISH BALL SCREW

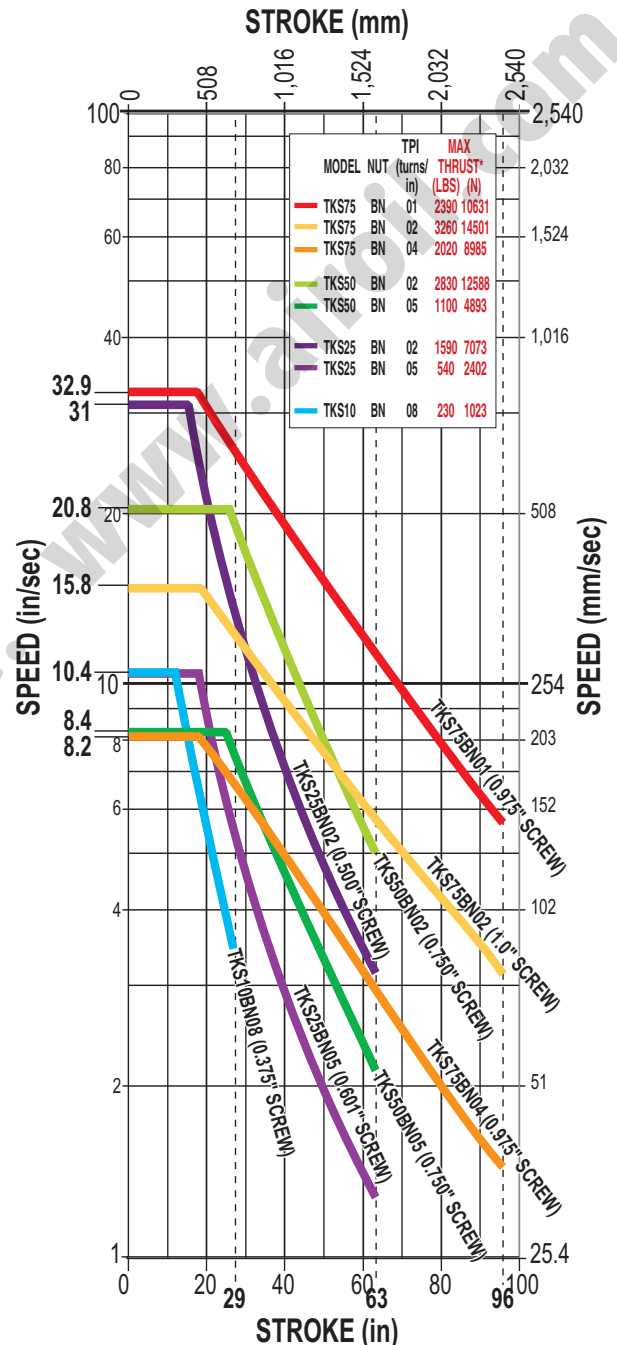

RODLESS

TKS Series

- Acme screw/nut combinations
- Acme screw critical speed
- Ball screw/nut combinations
- Ball screw critical speed



* For Acme screws, maximum thrust is the maximum continuous dynamic thrust subject to Thrust x Velocity limitation. For ball screws, maximum thrust reflects 90% reliability for 1 million linear inches of travel.

Dotted lines represent maximum stroke for screw selections.

For Acme Screw PV limits, refer to the individual charts located in the technical section for each actuator body size.

SCREW TYPE	DESCRIPTION
SN	Solid Nut
BN	Ball Nut

Axi dylene[®] TRUTrack™ TKS Screw Drives

BALL SCREW SPECIFICATIONS

TKS ENGLISH BALL SCREW LIFE CALCULATION

LIFE CAPACITIES WITH ENGLISH BALL SCREW

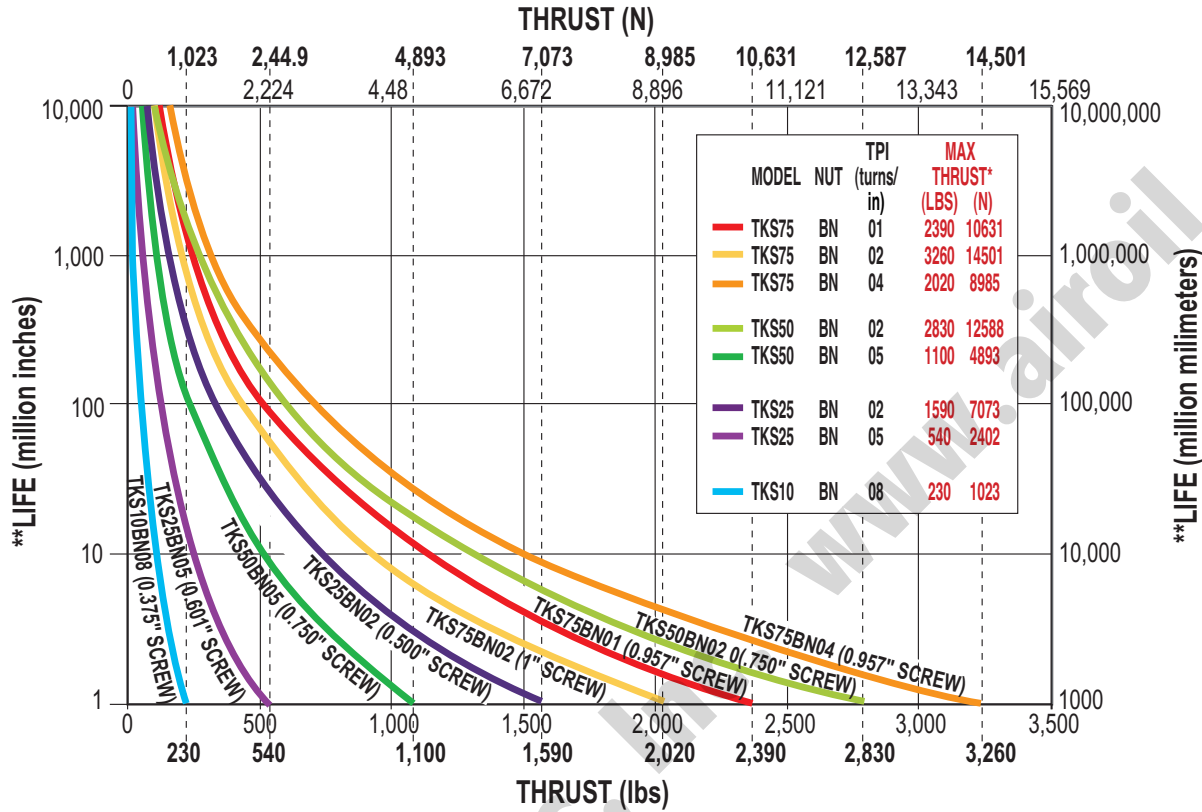

RODLESS

TKS Series
• Ball screw life capacities

SCREW TYPE **DESCRIPTION**
BN **Ball Nut**

⚠ *Maximum thrust reflects 90% reliability for 1 million linear inches of travel.

Dotted lines represent maximum thrust for screw selections.

**Life indicates theoretical maximum life of screw only, under ideal conditions and does not indicate expected life of actuator.

Axi-dyne[®] TRUTrack™ TKS Screw Drives

OVERALL SERIES SPECIFICATIONS

SPECIFICATIONS RELATED TO ACTUATOR SIZE AND SCREW SELECTION

TKS ENGLISH LEAD SCREWS											
ACTUATOR SERIES	SCREW DIA. (in)	SCREW TYPE	TPI (turns/in)	LEAD ACCURACY (in/ft)	BACKLASH (in)	MAXIMUM THRUST* (lb)	MAXIMUM STROKE (in)	INERTIA (lb-in ²)			BREAKAWAY TORQUE (lb-in)
								BASE ACTUATOR		PER/in OF STROKE	
								In Line	Rev. Parallel		
TKS10	0.500	SN	02	0.003	0.007	170	96	0.0126	0.0159	0.0017	0.938
	0.375	BN	08	0.004	0.002	230	29	0.0029	0.0038	0.0005	0.813
TKS25	0.500	SN	02	0.003	0.007	170	96	0.0263	0.0291	0.0017	1.750
	0.500	BN	02	0.004	0.002	1590	63	0.0263	0.0291	0.0017	1.438
TKS50	0.625	BN	05	0.004	0.002	540	63	0.0311	0.0380	0.0042	1.063
	0.750	SN	01	0.003	0.007	300	96	0.1472	0.1577	0.0087	3.750
TKS75	0.750	BN	02	0.004	0.002	2830	63	0.0867	0.0972	0.0087	1.875
	0.750	BN	05	0.004	0.002	1100	63	0.0698	0.0803	0.0087	1.500
TKS100	1.00	SN	04	0.003	0.007	400	96	0.2196	0.2737	0.0275	2.813
	1.00	BN	01	0.004	0.002	2390	96	0.3037	0.3578	0.0275	3.438
	1.00	BN	02	0.004	0.002	3260	96	0.2364	0.2905	0.0275	2.813
	1.00	BN	04	0.004	0.002	2020	96	0.2196	0.2737	0.0275	2.500

METRIC CONVERSIONS											
ACTUATOR SERIES	SCREW Ø (in)	SCREW TYPE	TPI (turns/in)	LEAD ACCURACY (mm/300)	BACKLASH (mm)	MAXIMUM THRUST* (N)	MAXIMUM STROKE (mm)	INERTIA (kg-m ² x 10 ⁻⁴)			BREAKAWAY TORQUE (N-m)
								BASE ACTUATOR		PER/mm OF STROKE	
								In Line	Rev. Parallel		
TKS10	0.50	SN	02	0.0762	0.1778	756	2438	3.69	4.65	0.50	0.11
	0.375	BN	08	0.1016	0.0508	1023	737	0.85	1.11	0.15	0.09
TKS25	0.50	SN	02	0.0762	0.1778	756	2438	7.69	8.51	0.49	0.20
	0.50	BN	02	0.1016	0.0508	7073	1600	7.69	8.51	0.49	0.16
TKS50	0.625	BN	05	0.1016	0.0508	2402	1600	9.10	11.12	2.17	0.12
	0.75	SN	01	0.0762	0.1778	1334	2438	43.06	46.13	2.54	0.42
TKS75	0.75	BN	02	0.1016	0.0508	12588	1600	25.36	28.43	2.54	0.21
	0.75	BN	05	0.1016	0.0508	4893	1600	20.42	23.49	2.54	0.17
TKS100	1.00	SN	04	0.0762	0.1778	1779	2438	64.23	80.06	8.04	0.31
	1.00	BN	01	0.1016	0.0508	10631	2438	88.83	104.66	8.04	0.39
	1.00	BN	02	0.1016	0.0508	14234	2438	69.15	84.97	8.04	0.31
	1.00	BN	04	0.1016	0.0508	8985	2438	64.23	80.06	8.04	0.28

⚠ Contact the factory for higher accuracy and lower backlash options.

* For Acme screws, maximum thrust is the maximum continuous dynamic thrust subject to Thrust x Velocity limitation. For ball screws, maximum thrust reflects 90% reliability for 1 million linear inches of travel.

SCREW TYPE	DESCRIPTION
SN	Solid Nut
BN	Ball Nut

RODLESS

TKS Series
• Actuator/Nut specifications

OVERALL SERIES SPECIFICATIONS

GENERAL ACTUATOR SPECIFICATIONS

SPECIFICATIONS	TKS ENGLISH ACTUATORS				METRIC CONVERSIONS			
	TKS10	TKS25	TKS50	TKS75	TKS10	TKS25	TKS50	TKS75
Carrier weight (lbs : kg)	0.56	2.31	3.18	3.54	0.25	1.05	1.44	1.61
Base weight in-line model (lbs : kg) (including carrier without motor)	3.22	9.46	14.56	17.95	1.46	4.29	6.60	8.14
Weight per/in (mm) of stroke (lbs : kg)	0.229	0.527	0.728	0.932	0.10	0.24	0.33	0.42
Straightness (YX Plane) (unconstrained ¹) (in/in : mm/mm)	0.0004	0.0004	0.0004	0.0004	0.0004	0.0004	0.0004	0.0004
Straightness (YX Plane) (constrained ²) (in/in : mm/mm)	0.0002	0.0002	0.0002	0.0002	0.0002	0.0002	0.0002	0.0002
Flatness (ZX Plane) (unconstrained ¹) (in/in : mm/mm)	0.0008	0.0008	0.0008	0.0008	0.0008	0.0008	0.0008	0.0008
Flatness (ZX Plane) (constrained ²) (in/in : mm/mm)	0.0002	0.0002	0.0002	0.0002	0.0002	0.0002	0.0002	0.0002
Screw uni-directional repeatability ³ (in : mm)	±0.0004	±0.0004	±0.0004	±0.0004	±0.010	±0.010	±0.010	±0.010
Temperature Range ⁴ (F° : C°)	40-130	40-130	40-130	40-130	4-54	4-54	4-54	4-54



RODLESS

TKS Series

- General actuator specifications
- Friction force
- Lubrication
- Mounting recommendations



¹ Listed values are intended for reference purposes only, and not as an engineering standard of absolute tolerance for a given actuator. Values were derived from testing of characteristic samples of appropriate products, and indicate an expected range of deviation from a theoretical straight line in the indicated plane of carrier motion. Appropriate installation is the single most important factor in reducing such deviation, so good engineering practices such as measurement, mapping, etc. must be employed in applications with stringent straightness/flatness requirements. For more information on how these values were obtained, please read the white paper on this subject available at www.tolomatic.com.

² Actuator mounted on a flat surface and fully restrained. (See dimensional drawings on pages C-58, C-64, C-70 and C-76)

³ Ball screw; not including backlash

⁴ Heat generated by the motor and drive should be taken into consideration as well as linear velocity and work cycle time. For applications that require operation outside of the recommended temperature range, contact the factory.

LARGE FRAME MOTORS AND SMALLER SIZE ACTUATORS: Cantilevered motors need to be supported, if subjected to continuous rapid reversing duty and/or under dynamic conditions.

FRICITION FORCE

$$lbf = 0.0003 \times \text{LOAD (lb)} + 3.96$$

$$N = 0.003 \times \text{LOAD (kg)} + 17.6$$

LUBRICATION

Proper and adequate lubrication is essential for normal operation of TruTrack actuators. Poor lubrication will cause quicker wear and decrease service life of the actuator. For general use, lubrication should be performed at intervals of 4,000,000 linear inches of travel (100 km) or once every year, whichever occurs first. However, the operating conditions of certain applications may require more frequent lubrication. Please consult Tol-O-Matic for recommendations.

Recommended greases:

- Multi-purpose grease based on refined mineral oil containing lithium thickening agent (excellent at high pressures, excellent viscosity stability).
- Grease based on a high-grade synthetic oil containing a urea thickening agent (long life, wide temperature range).

MOUNTING RECOMMENDATIONS

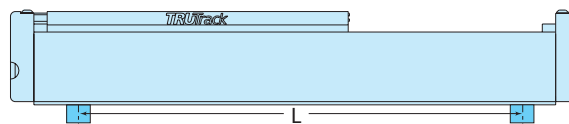
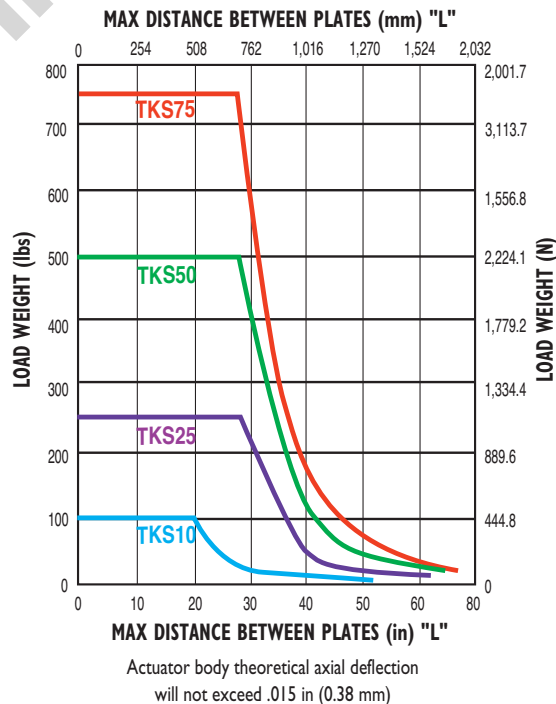

Axi-dyne[®] TRUTrack™ TKS Screw Drives

OVERALL SERIES SPECIFICATIONS

BENDING MOMENTS AND LOADS

STANDARD CARRIER		MAXIMUM BENDING MOMENTS AND LOADS*				ENGLISH		METRIC CONVERSIONS		
		TKS10	TKS25	TKS50	TKS75	TKS10	TKS25	TKS50	TKS75	
	Maximum Dynamic Bending Moments									
	Mx (Roll)	(lb-in : N-m)	85	721	971	1151	9.6	81.5	109.7	130.0
	My (Pitch)	(lb-in : N-m)	234	1014	1442	1477	26.4	114.6	162.9	166.9
	Mz (Yaw)	(lb-in : N-m)	234	915	1301	1332	26.4	103.4	147.0	150.5
	Maximum Dynamic Loads									
	Fy (Radial Load)	(lb : N)	100	250	500	750	445	1113	2225	3338
	Fz (Lateral Load)	(lb : N)	100	250	500	750	445	1113	2225	2225
	Fzr (Reverse Lateral Load)	(lb : N)	100	250	500	750	445	1113	2225	2225
	Maximum Static Bending Moments									
	Mx (Roll)	(lb-in : N-m)	170	1251	1685	1997	19.2	141.3	190.3	225.6
	My (Pitch)	(lb-in : N-m)	468	1759	2502	2563	52.9	198.8	282.7	289.5
	Mz (Yaw)	(lb-in : N-m)	468	1588	2257	2311	52.9	179.4	255.0	261.1
Maximum Static Loads										
Fy (Radial Load)	(lb : N)	200	434	868	1301	890	1931	3863	5789	
Fz (Lateral Load)	(lb : N)	200	434	868	868	890	1931	3863	3863	
Fzr (Reverse Lateral Load)	(lb : N)	200	434	868	868	890	1931	3863	3863	
AUXILIARY CARRIER: Increases rigidity, load-carrying capacity and moments		TKS10	TKS25	TKS50	TKS75	TKS10	TKS25	TKS50	TKS75	
	Maximum Dynamic Bending Moments									
	Mx (Roll)	** (lb-in : N-m)	170	1442	1942	2302	19.2	162.9	219.4	260.1
	My (Pitch)	** (lb-in : N-m)	563	1733	3810	3875	63.6	195.7	430.5	437.8
	Mz (Yaw)	** (lb-in : N-m)	563	1733	3810	3875	63.6	195.7	430.5	437.8
	Maximum Dynamic Loads									
	Fy (Radial Load)	(lb : N)	200	500	1000	1500	890	2225	4450	6675
	Fz (Lateral Load)	(lb : N)	200	500	1000	1500	890	2225	4450	4450
	Fzr (Reverse Lateral Load)	(lb : N)	200	500	1000	1500	890	2225	4450	4450
	Maximum Static Bending Moments									
	Mx (Roll)	** (lb-in : N-m)	340	2502	3369	3994	38	283	381	451
	My (Pitch)	** (lb-in : N-m)	1126	3006	6610	6723	127	340	747	760
	Mz (Yaw)	** (lb-in : N-m)	1126	3006	6610	6723	127	340	747	760
Maximum Static Loads										
Fy (Radial Load)	(lb : N)	400	868	1735	2603	1780	3863	7721	11583	
Fz (Lateral Load)	(lb : N)	400	868	1735	1735	1780	3863	7721	7721	
Fzr (Reverse Lateral Load)	(lb : N)	400	868	1735	1735	1780	3863	7721	7721	
Minimum Dimension 'D'	(in : mm)	5.63	6.93	7.63	7.75	142.9	176.0	193.8	196.9	



* Bending moments are based on 200,000 (5,000 KM) linear inches of carrier travel.

Breakaway torque will increase when using the Auxiliary carrier option. When ordering, determine your working stroke and enter this value into the configuration string. Overall actuator length will automatically be calculated.

Deflection Considerations: In applications where substantial Mx or My moments come into play, deflection of the cylinder tube, carrier and supports must be considered. The deflection factors shown in the Load Deflection charts, are based on cylinder mounted with tube supports at minimum recommended spacing. If more rigidity is desired, refer to the Auxiliary or Dual Carrier options.

** Loads shown in table are at minimum "D" dimension, for ratings with longer "D" dimension see graph on page C-57.

Axi-dyne® TRUtrack™ TKS Screw Drives

OVERALL SERIES SPECIFICATIONS

LOAD DEFLECTION

X-AXIS DEFLECTION

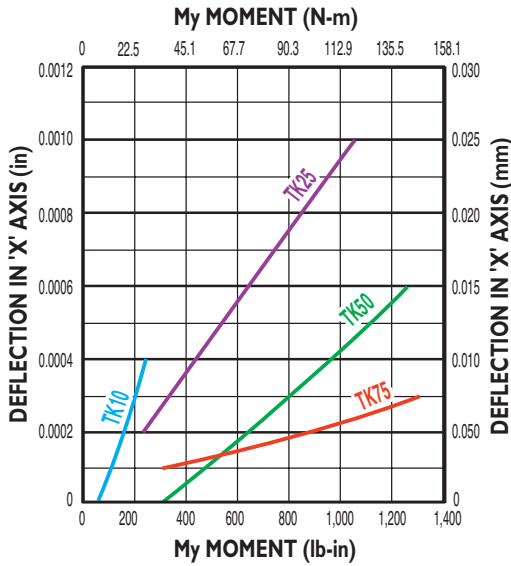
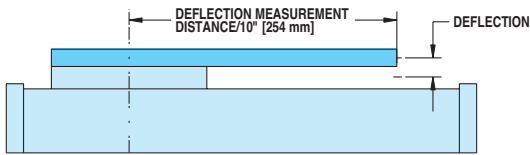

Y-AXIS DEFLECTION

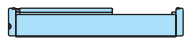
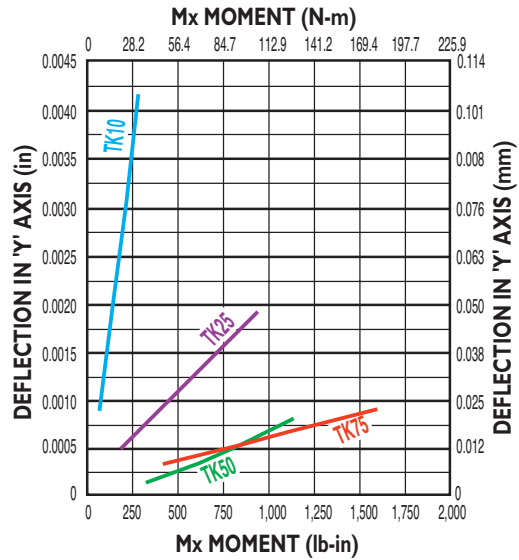
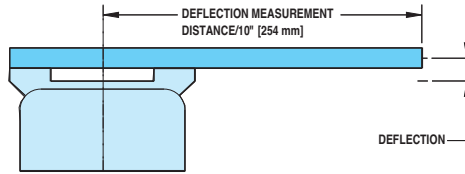

RODLESS

- TKS Series
- Load deflection
- Auxiliary Carrier

AUXILIARY CARRIER: BENDING MOMENT AT 'D' DISTANCE

DYNAMIC BENDING MOMENT

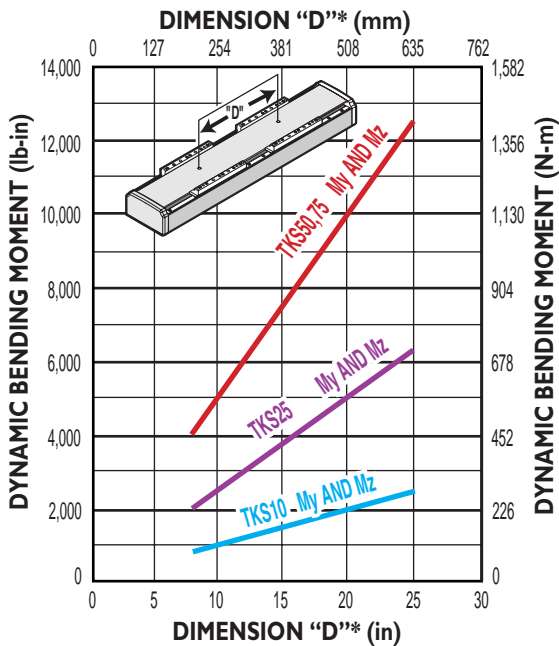

STATIC BENDING MOMENT

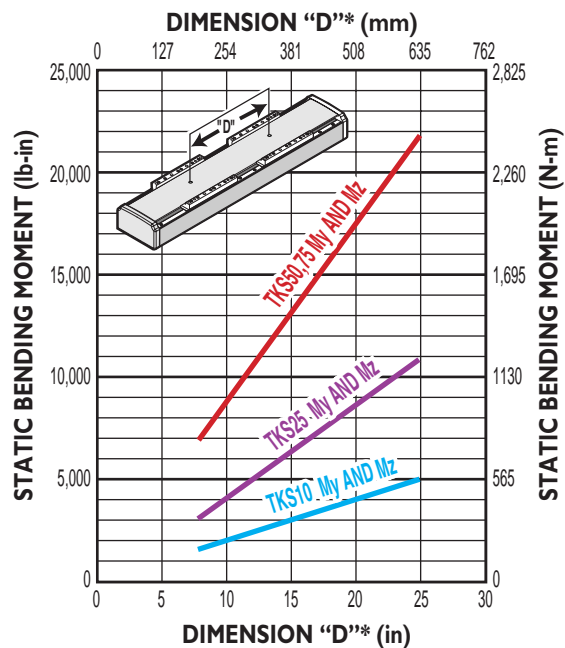

- Rates shown on charts were calculated with these assumptions:
- 1.) Coupling between carriers is rigid.
 - 2.) Load is equally distributed between carriers.
 - 3.) Coupling device applies no misalignment loads to carriers.

* Customer must specify Dimension "D" (Distance between carrier center lines) in configuration string.

Axi-dyne® TRUTrack™ TKS Screw Drives

OVERALL SERIES SPECIFICATIONS

BELLOWS STROKE REQUIREMENTS

STANDARD ACTUATOR

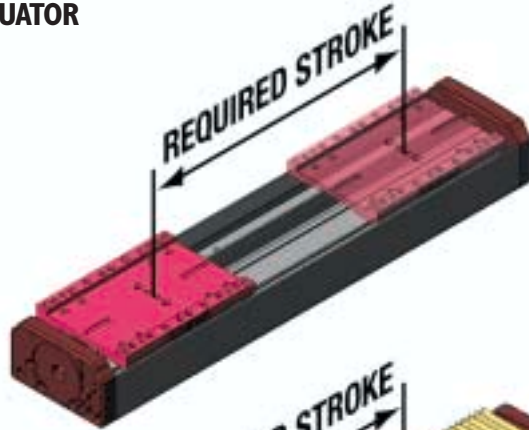

STANDARD ACTUATOR WITH BELLOWS COVER

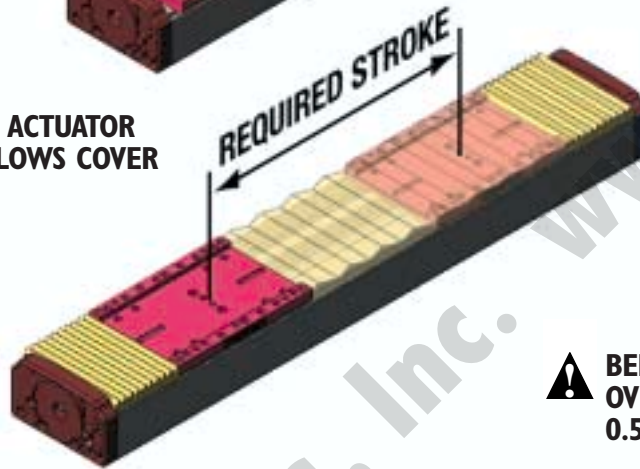

⚠ BELLOWS COVER OPTION INCREASES OVERALL ACTUATOR LENGTH BY 0.508 x STROKE

MAXIMUM AVAILABLE STROKE FOR BELLOWS OPTION	WITH BALL NUT	WITH SOLID NUT
TKS10	24 inches (610 mm)	64 inches (1626 mm)
TKS25	44 inches (1118 mm)	64 inches (1626 mm)
TKS50	56 inches (1422 mm)	64 inches (1626 mm)
TKS75	64 inches (1626 mm)	64 inches (1626 mm)

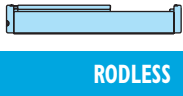

TKS Series
• Bellows stroke requirements

TRUtrack™ TKS10 Series

SCREW SPECIFICATIONS



TKS10 ACME SCREW CRITICAL SPEED AND PV LIMITS

CRITICAL SPEED WITH 0.500" 2TPI ENGLISH ACME SCREW

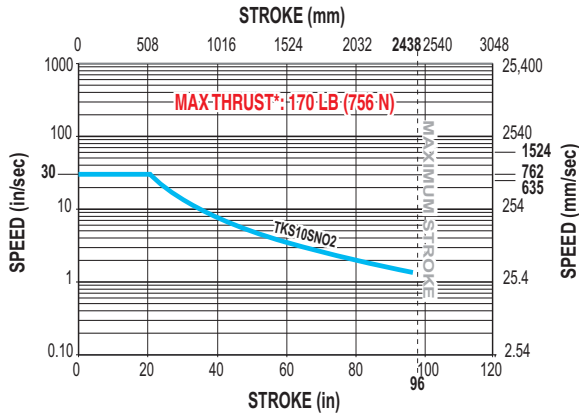

PV LIMITS: 0.500" 2 TPI ENGLISH ACME SCREW

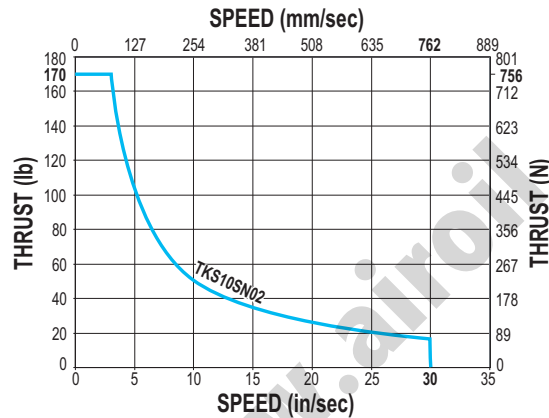

RODLESS

TKS10 Series

- Acme screw critical speed capacities and PV limits
- Ball screw critical speed capacities and life calculations

SN = Solid Nut



* Maximum thrust is the maximum continuous dynamic thrust subject to Thrust x Velocity limitation.

PV LIMITS: Any material which carries a sliding load is limited by heat buildup. The factors that affect heat generation rate in an application are the pressure on the nut in pounds per square inch and the surface velocity in feet per minute. The product of these factors provides a measure of the severity of an application.

$$P = \frac{\text{Thrust}}{\text{Max. Thrust Rating}} \times V = \frac{\text{Speed}}{\text{Max. Speed Rating}} \leq 0.1$$

TKS10 BALL SCREW CRITICAL SPEED AND LIFE CALCULATIONS

CRITICAL SPEED WITH 0.375" 8TPI ENGLISH BALL SCREW

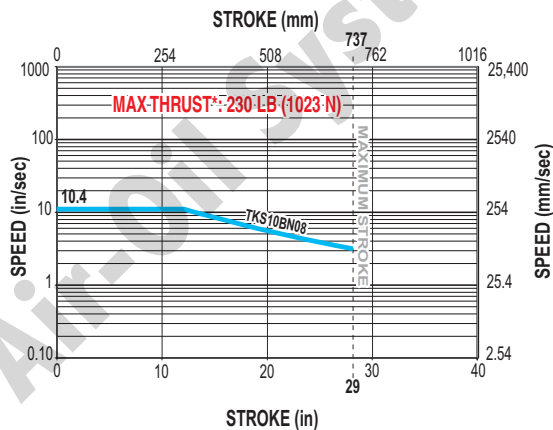

LIFE CALCULATION: 0.375" 8TPI ENGLISH BALL SCREW

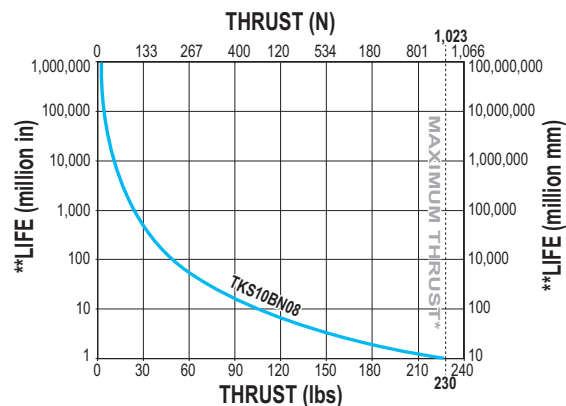

BN = Ball Nut



* Maximum thrust reflects 90% reliability for 1 million linear inches of travel.

**Life indicates theoretical maximum life of screw only, under ideal conditions and does not indicate expected life of actuator.

Axi-dyne® TRUTrack™ TKS10 Series

DIMENSIONS

TKS10 ACTUATOR AND OPTIONS



RODLESS

TKS10 Series

- Actuator and options dimensions

OPTIONAL MOUNTING PLATE

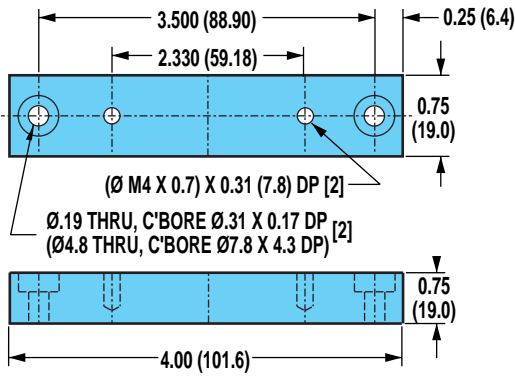

MOTOR END (END VIEW)

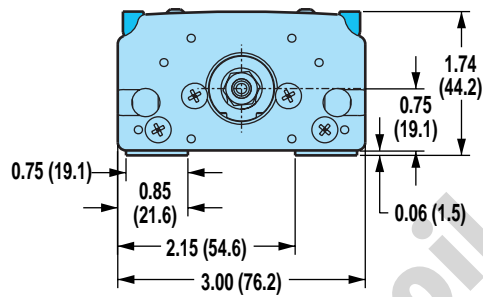

MOTOR END (IDLE END REVERSE PARALLEL (RP) UNITS)

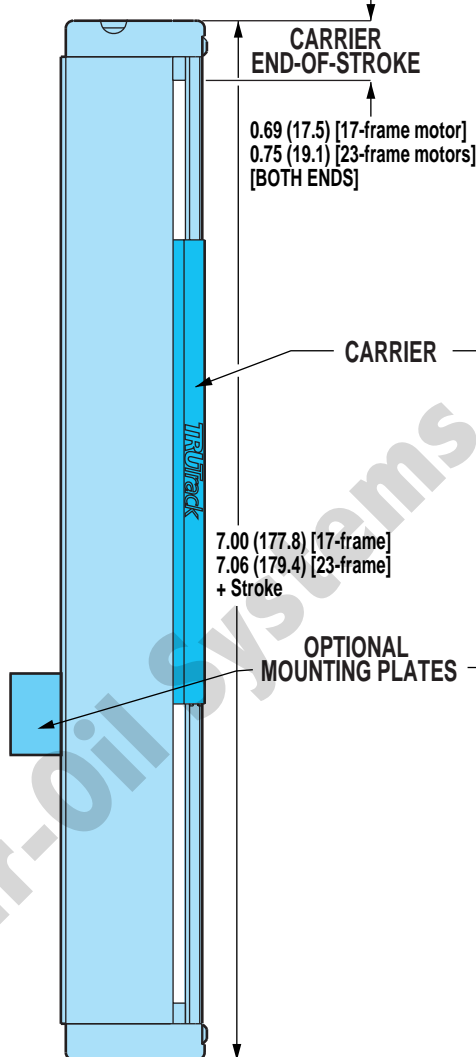

IDLE END (MOTOR END REVERSE PARALLEL (RP) UNITS)

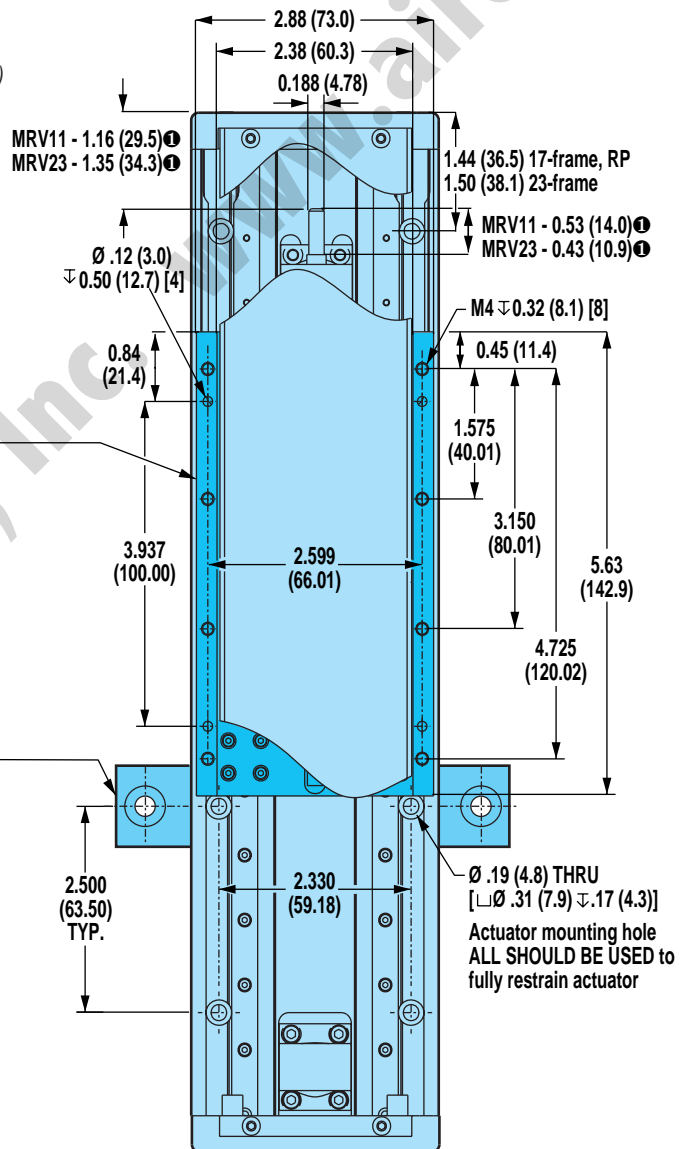

IDLE END (MOTOR END REVERSE PARALLEL (RP) UNITS)

① WHEN SPECIFYING THE XY/XJ SHAFT OPTION: IF A TOL-O-MATIC MOTOR IS NOT SPECIFIED IN THE CONFIGURATION STRING, CUSTOMER'S MOTOR MUST CONFORM TO THE SHAFT DIMENSIONS SHOWN FOR MOUNTING COMPATIBILITY. PLEASE SPECIFY YOUR MOTOR TYPE AND FRAME SIZE WHEN ORDERING.

Unless otherwise noted, all dimensions shown are in inches (Dimensions in parenthesis are in millimeters)

DIMENSIONS

TKS10: DOUBLE C-FACE BRAKE OPTION

BRAKE FOR 23-FRAME MOTOR

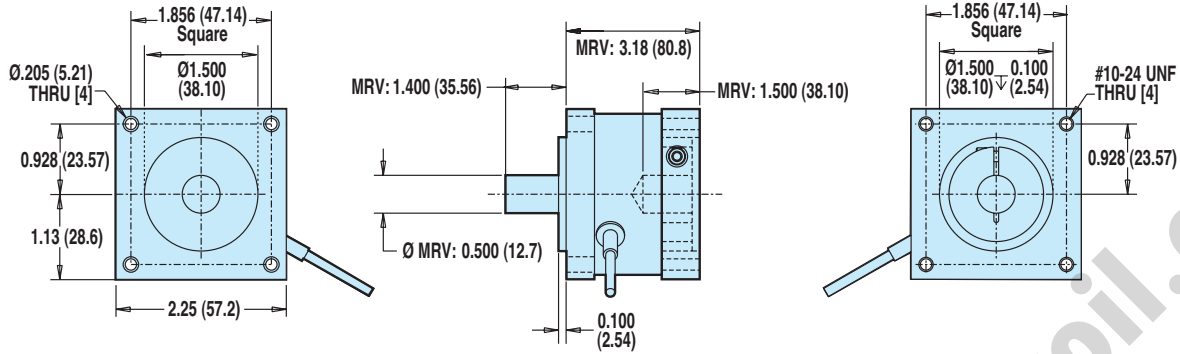

RODLESS

TKS10 Series
• Double C-face Brake dimensions

MOTOR TYPE	MOTOR/ FRAME	BRAKE PART NO.	STATIC TORQUE		REFLECTED INERTIA		WEIGHT		VOLTAGE	CURRENT	RESISTANCE	CABLE LENGTH	
			lb-in	N-m	lb-in ²	kg-m ² x 10 ⁻⁴	lb	kg				in	mm
BRUSHLESS	MRV 23	3600-6286	10	1.130	0.0125	3.66	10.6	0.48	24	0.182	132.0	16.75	425

MAXIMUM BRAKE HOLDING LOADS						
LEADSCREW/NUT REDUCTION	23-FRAME BRAKE					
	INLINE		5.5:1 GEARHEAD		10:1 GEARHEAD	
	lb	kg	lb	kg	lb	kg
TKS10 with SN02	180	81.6	180	81.6	180	81.6
TKS10 with BN08	559	253.5	1874	850.0	1874	850.0

⚠ Double C-face brakes are used for static holding (back driving prevention) and are not designed for dynamic stopping. Please contact Tol-O-Matic if your application requires dynamic stopping. This brake can be used with other Tol-O-Matic systems. Consult the factory for availability.

DIMENSIONS

TKS10: IN-LINE MOUNT FOR 17-FRAME BRUSHLESS (MRV) MOTORS

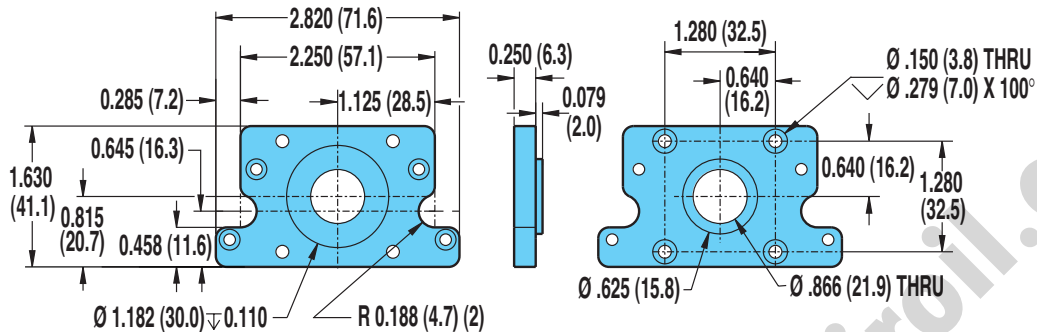

! 17-frame MRV motors cannot be mounted directly to the actuator head and require the use of the motor adapter plate shown. Gearhead option is not available with 17-frame motors.

TKS10: IN-LINE MOUNT FOR 23-FRAME BRUSHLESS (MRV) MOTORS OR GEARHEAD

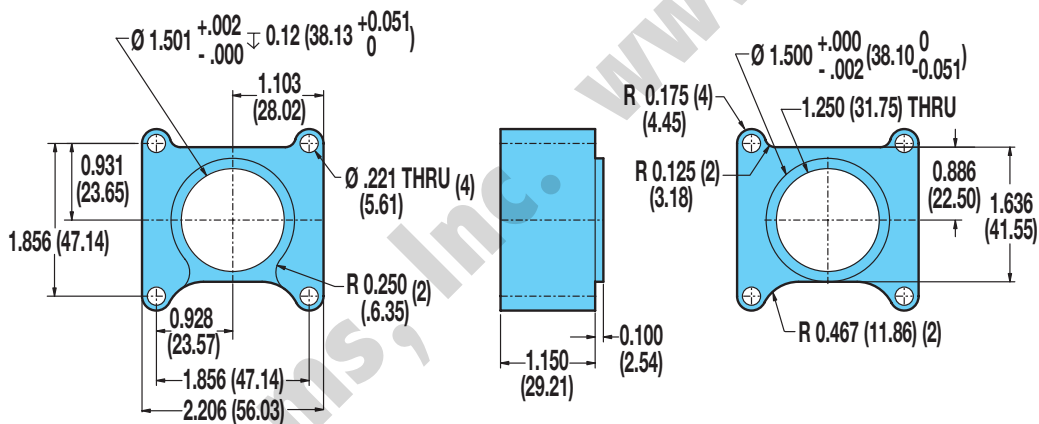

! 23-frame brushless MRV motors cannot be mounted directly to the actuator head and requires the use of the motor adapter plate shown.



INTERCHANGING MOTORS: Leadscrews on TruTrack actuators are specific to the motor type specified. Motor mounting plates do not provide for interchanging servo or stepper motors.

For gearhead dimensions and specifications, refer to page F-10.

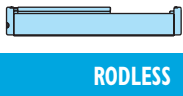

RODLESS

TKS10 Series

- In-line motor mount dimensions
- Shaft xy/xj option

Axi-dyne® TRUTrack™ TKS10 Series

DIMENSIONS

TKS10: REVERSE PARALLEL MOUNTING

BOTTOM MOUNT

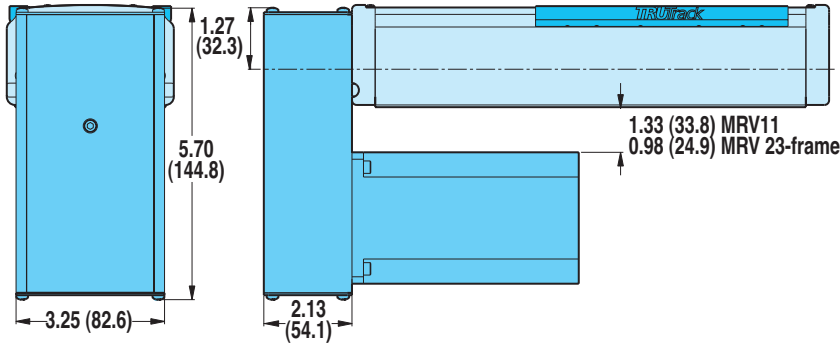

TOP MOUNT

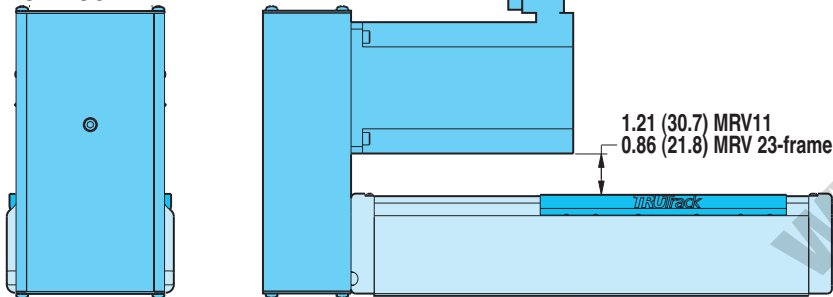

SIDE MOUNT

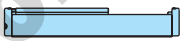
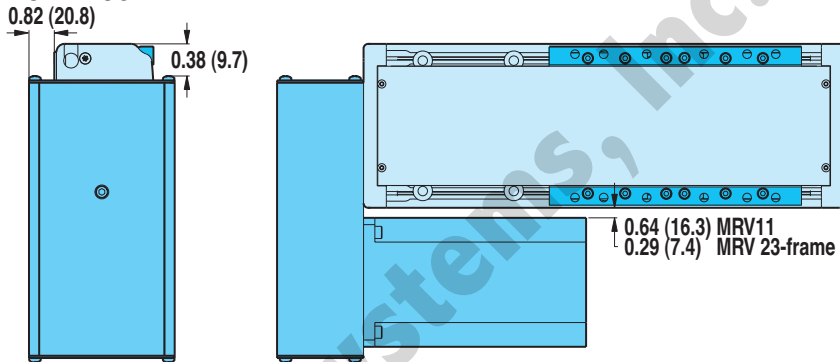

RODLESS

TKS10 Series

- Reverse parallel mounting

SPECIFICATIONS

MOTOR	WEIGHT OF REDUCTION DRIVE				REDUCTION INERTIA AT MOTOR SHAFT			
	1:1		2:1		1:1 RATIO		2:1 RATIO	
	lbs	kg	lbs	kg	lb-in ²	kg-cm ²	lb-in ²	kg-cm ²
BRUSHLESS MRV 11, 21, 22 23, 24	1.80	0.82	1.80	0.82	.039	.1141	.047	.1368

REDUCTION EFFICIENCY: 0.95



Axi dylene® TRUTrack™ TKS25 Series ACME SCREW SPECIFICATIONS

TKS25 ACME SCREW CRITICAL SPEED AND PV LIMITS

CRITICAL SPEED WITH 0.500" ENGLISH ACME SCREW

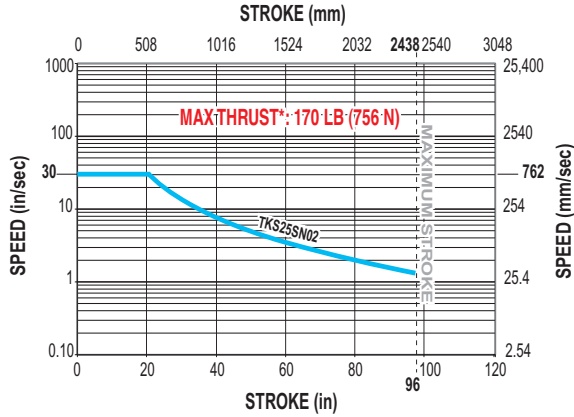

PV LIMITS: 1/2" 2 TPI ENGLISH ACME SCREW

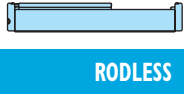
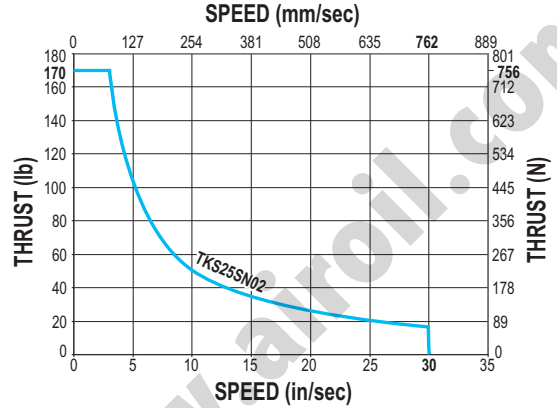

TKS25 Series
• Acme screw critical speed capacities and PV limits

SN = Solid Nut



* Maximum thrust is the maximum continuous dynamic thrust subject to Thrust x Velocity limitation.

PV LIMITS: Any material which carries a sliding load is limited by heat buildup. The factors that affect heat generation rate in an application are the pressure on the nut in pounds per square inch and the surface velocity in feet per minute. The product of these factors provides a measure of the severity of an application.

$$P = \frac{\text{Thrust}}{\text{Max. Thrust Rating}} \times V = \frac{\text{Speed}}{\text{Max. Speed Rating}} \leq 0.1$$

TRUtrack™ TKS25 Series

BALL SCREW SPECIFICATIONS

TKS25 BALL SCREW CRITICAL SPEED AND LIFE CALCULATIONS

CRITICAL SPEED WITH 0.500" 2TPI ENGLISH BALL SCREW

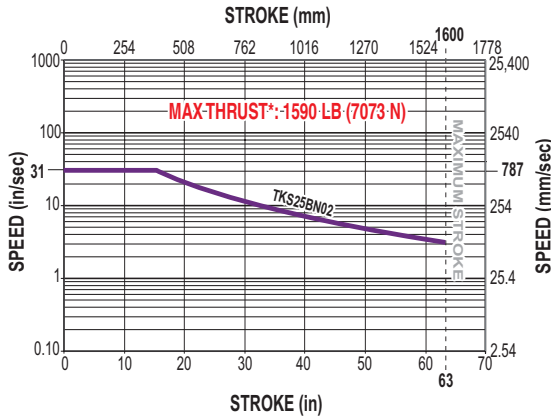

LIFE CALCULATION: 0.500" 2TPI ENGLISH BALL SCREW

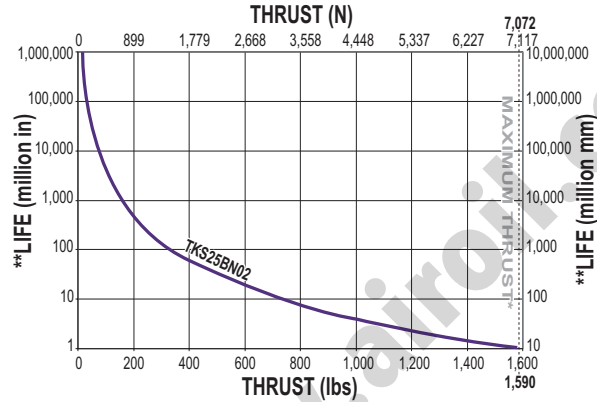

RODLESS

TKS25 Series

- Ball screw critical speed capacities and life calculations

CRITICAL SPEED WITH 0.601" 5TPI ENGLISH BALL SCREW

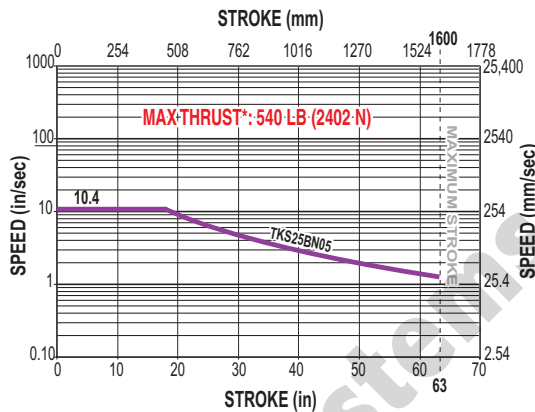

LIFE CALCULATION: 0.601" 5TPI ENGLISH BALL SCREW

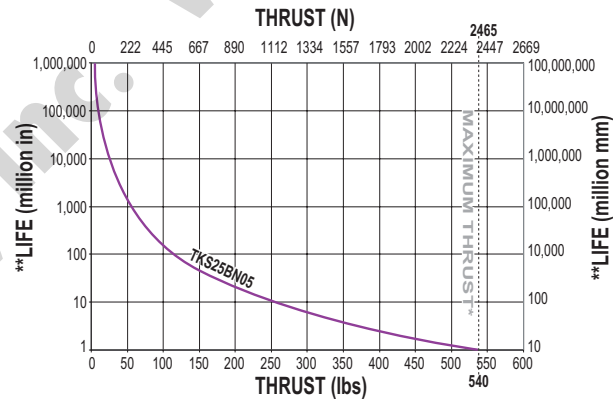

BN = Ball Nut



* Maximum thrust reflects 90% reliability for 1 million linear inches of travel.

**Life indicates theoretical maximum life of screw only, under ideal conditions and does not indicate expected life of actuator.

Axi-dyne[®] TRUTrack™ TKS25 Series

DIMENSIONS

TKS25 ACTUATOR AND OPTIONS

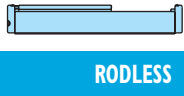

RODLESS

TKS25 Series

• Actuator and options dimensions

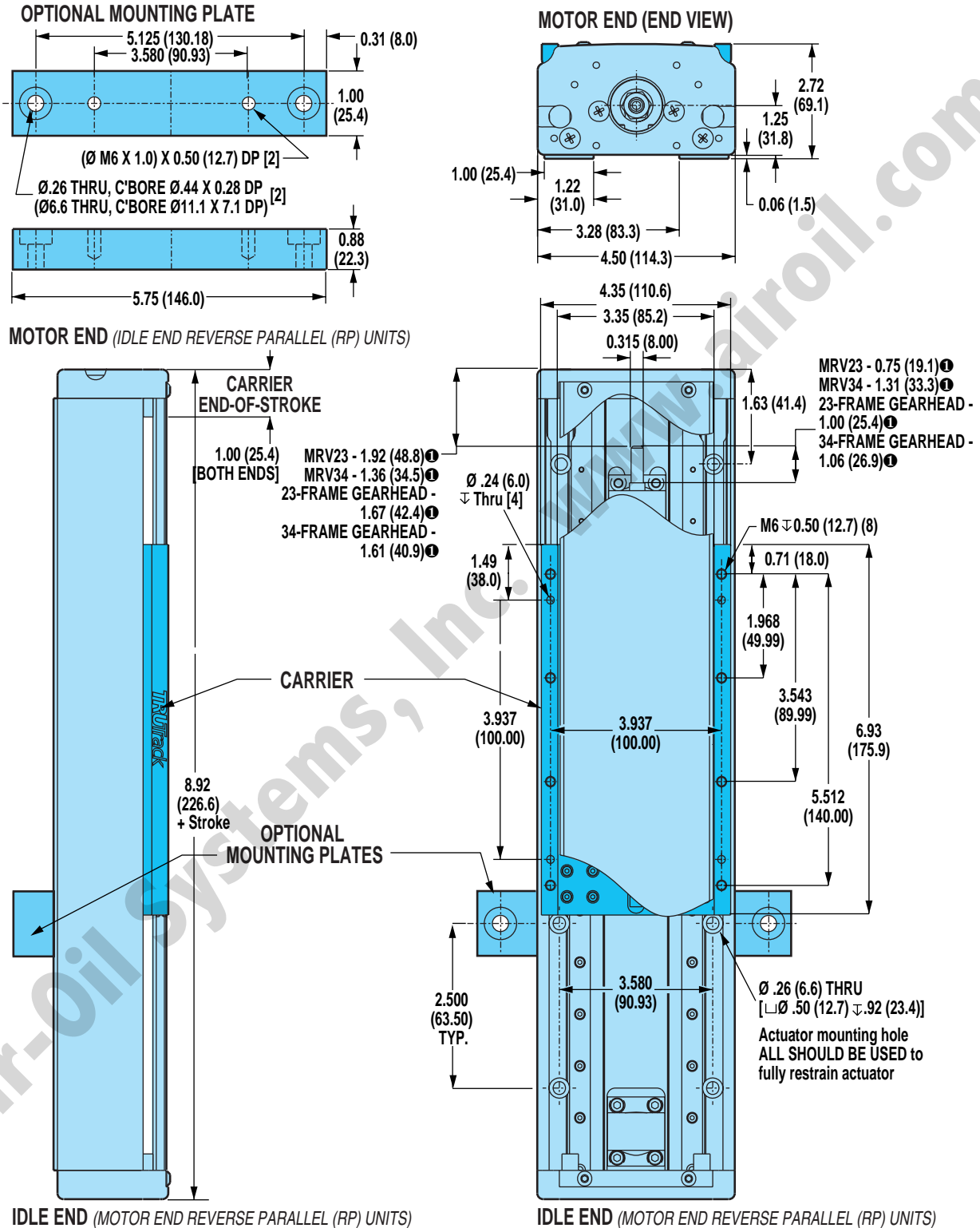

Ⓢ WHEN SPECIFYING THE XY/XJ SHAFT OPTION: IF A TOL-O-MATIC MOTOR IS NOT SPECIFIED IN THE CONFIGURATION STRING, CUSTOMER'S MOTOR MUST CONFORM TO THE SHAFT DIMENSIONS SHOWN FOR MOUNTING COMPATIBILITY. PLEASE SPECIFY YOUR MOTOR TYPE AND FRAME SIZE WHEN ORDERING.

Unless otherwise noted, all dimensions shown are in inches (Dimensions in parenthesis are in millimeters)

Axi-dyne[®] TRUTrack™ TKS25 Series

DIMENSIONS

TKS25: DOUBLE C-FACE BRAKE OPTION

BRAKE FOR 23-FRAME MOTOR

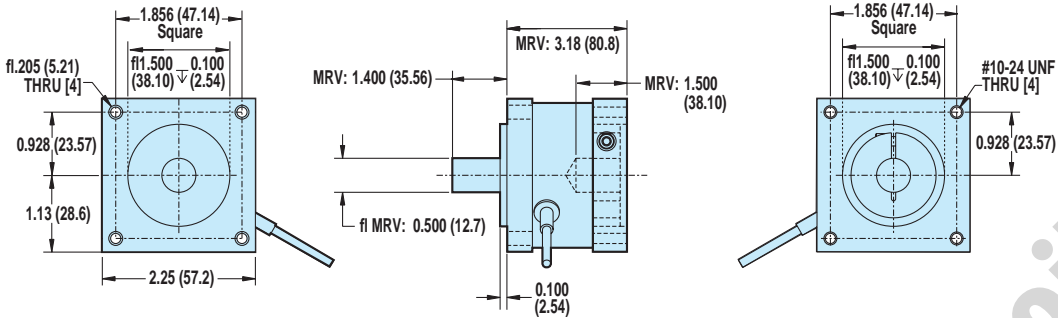

BRAKE FOR 34-FRAME MOTOR

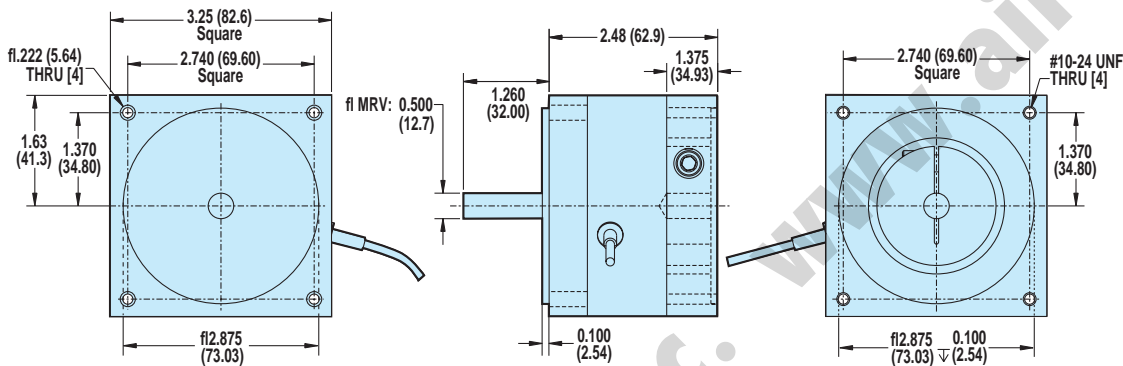

RODLESS

TKS25 Series

- Double C-face brake option dimensions

MOTOR TYPE	MOTOR/ FRAME	BRAKE PART NO.	STATIC TORQUE		REFLECTED INERTIA		WEIGHT		VOLTAGE	CURRENT	RESISTANCE	CABLE LENGTH	
			lb-in	N-m	lb-in ²	kg-M ² x10 ⁻⁴	lb	kg				in	mm
BRUSHLESS	MRV 23	3600-6286	10	1.130	0.0125	3.66	1.49	0.68	24	0.286	83.6	16.75	425
	MRV 34	3600-6288	25	2.825	0.1087	31.79	2.88	1.31	24	0.369	65.1	18.0	457

MAXIMUM BRAKE HOLDING LOADS

LEADSCREW/NUT REDUCTION	23-FRAME BRAKE						34-FRAME BRAKE					
	INLINE		5.5:1 GEARHEAD		10:1 GEARHEAD		INLINE		5.5:1 GEARHEAD		10:1 GEARHEAD	
	lb	kg	lb	kg	lb	kg	lb	kg	lb	kg	lb	kg
TKS25 with SN02	180	81.6	180	81.6	180	81.6	180	81.6	180	81.6	180	81.6
TKS25 with BN02	140	63.5	903	409.5	1643	745.2	349	158.3	2259	1024.6	4107	1862.8
TKS25 with BN05	349	158.3	2259	1024.6	4008	1817.9	873	395.9	4008	1817.9	4008	1817.9

⚠ Double C-face brakes are used for static holding (back driving prevention) and are not designed for dynamic stopping. Please contact Tol-O-Matic if your application requires dynamic stopping. This brake can be used with other Tol-O-Matic systems. Consult the factory for availability.

Axi-dyne® TRUTrack™ TKS25 Series

DIMENSIONS

**TKS25: IN-LINE MOUNT FOR 34-FRAME BRUSHLESS (MRV) MOTORS,
OR 34-FRAME GEARHEAD**

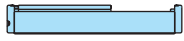

RODLESS

TKS Series
• In-line motor mounting

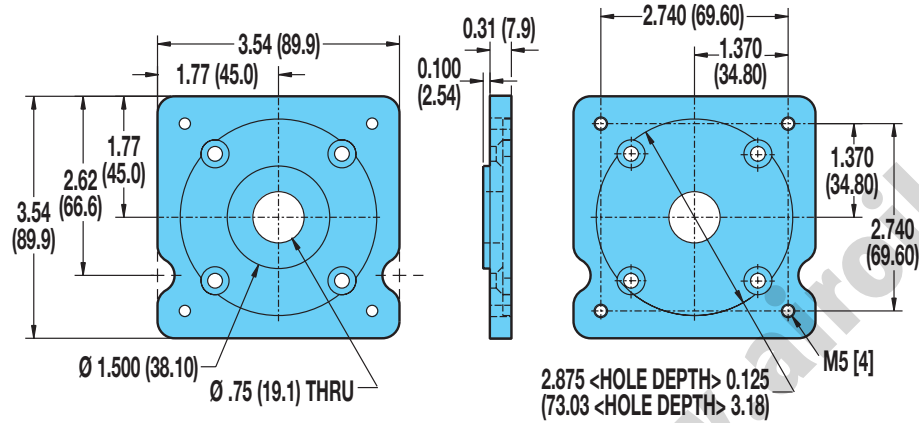

! *23-frame brushless MRV motors are mounted directly to the actuator head and require no motor adapter plates.
34-frame brushless MRV motors cannot be mounted directly to the actuator head and require the use of the motor adapter plate shown.*

! ***INTERCHANGING MOTORS:** Leadscrews on TruTrack actuators are specific to the motor type specified. Motor mounting plates do not provide for interchanging servo or stepper motors.*

For gearhead dimensions and specifications, refer to page F-10

Axi-dyne® TRUTrack™ TKS25 Series

DIMENSIONS

TKS25: REVERSE PARALLEL MOUNTING

BOTTOM MOUNT

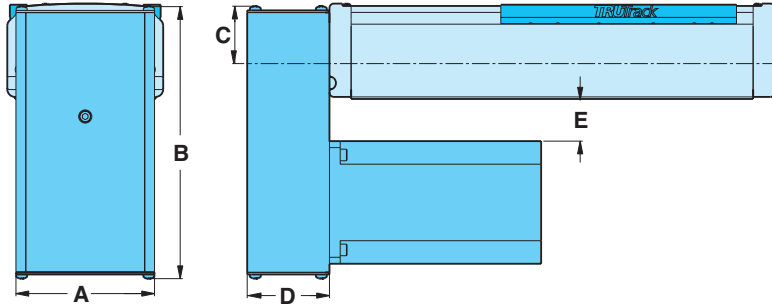

TOP MOUNT

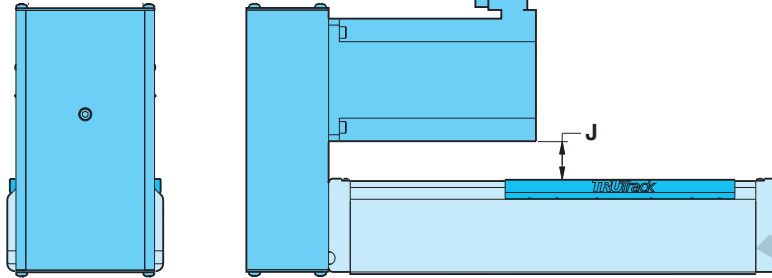

SIDE MOUNT

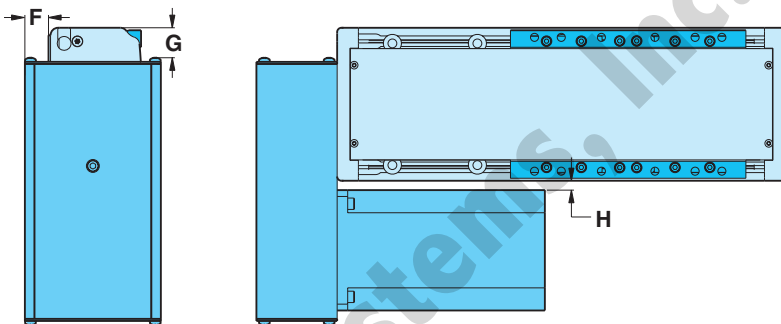

SPECIFICATIONS

BRUSHLESS	MOTOR	WEIGHT OF REDUCTION DRIVE			
		1:1		2:1	
		lbs	kg	lbs	kg
	MRV21, 22, 23, 24	2.51	1.14	2.74	1.24
	MRV31, 32, 33	2.75	1.25	2.98	1.35

RODLESS

TKS25 Series

- Reverse parallel mounting

BRUSHLESS	MOTOR	REDUCTION INERTIA AT MOTOR SHAFT			
		1:1		2:1	
		in-lb ²	kg-cm ²	in-lb ²	kg-cm ²
	MRV21, 22, 23, 24	.038	.1112	.103	.3014
	MRV31, 32, 33	.038	.1112	.103	.3014

REDUCTION EFFICIENCY: 0.95

DIMENSIONS

BRUSHLESS	MOTORS	A		B		C		D		E		F		G		H		J	
		in.	mm	in.	mm	in.	mm	in.	mm	in.	mm	in.	mm	in.	mm	in.	mm	in.	mm
	MRV21, 22, 23, 24	3.25	82.6	7.02	178.4	1.33	33.8	2.13	54.1	1.74	44.2	0.32	8.1	1.07	27.2	0.80	20.3	1.78	45.2
	MRV31, 32, 33	4.00	101.6	7.79	197.9	1.33	33.8	2.38	60.5	0.97	24.6	0.69	17.5	1.07	27.2	0.15	3.8	1.01	25.7



Axi-dyne® TRUTrack™ TKS50 Series ACME SCREW SPECIFICATIONS

TKS50 ACME SCREW CRITICAL SPEED AND PV LIMITS

CRITICAL SPEED WITH 0.750" ITPI ENGLISH ACME SCREW

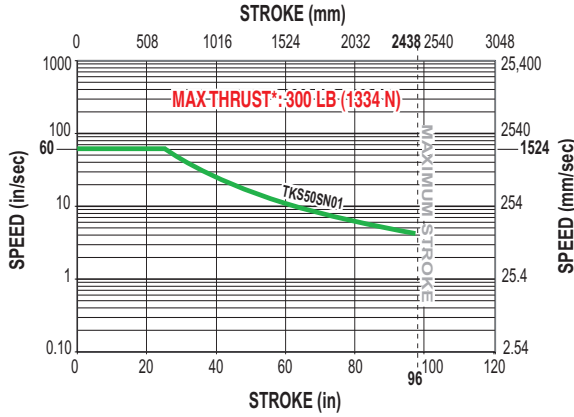

PV LIMITS: 0.750" ITPI ENGLISH ACME SCREW

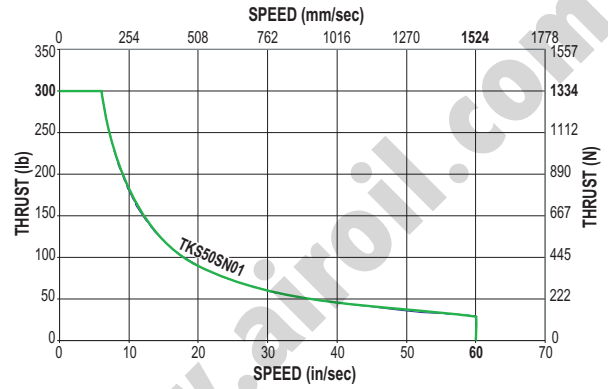

RODLESS

TKS50 Series

- Acme screw critical speed capacities and PV limits

SN = Solid Nut



* *Maximum thrust is the maximum continuous dynamic thrust subject to Thrust x Velocity limitation.*

PV LIMITS: Any material which carries a sliding load is limited by heat buildup. The factors that affect heat generation rate in an application are the pressure on the nut in pounds per square inch and the surface velocity in feet per minute. The product of these factors provides a measure of the severity of an application.

$$P = \frac{\text{Thrust}}{\text{Max. Thrust Rating}} \times V = \frac{\text{Speed}}{\text{Max. Speed Rating}} \leq 0.1$$

TRUtrack™ TKS50 Series

BALL SCREW SPECIFICATIONS

TKS50 BALL SCREW CRITICAL SPEED AND LIFE CALCULATIONS

CRITICAL SPEED WITH 0.750" 2TPI ENGLISH BALL SCREW

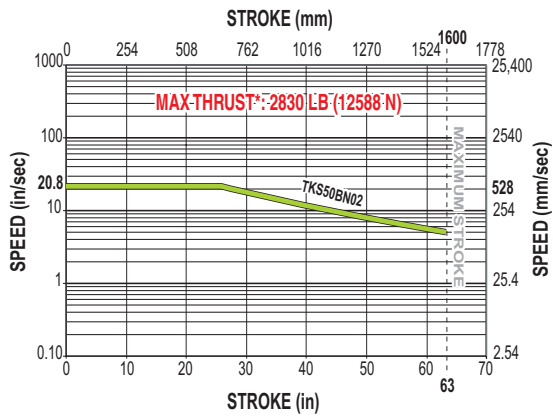

LIFE CALCULATION: 0.750" 2TPI ENGLISH BALL SCREW

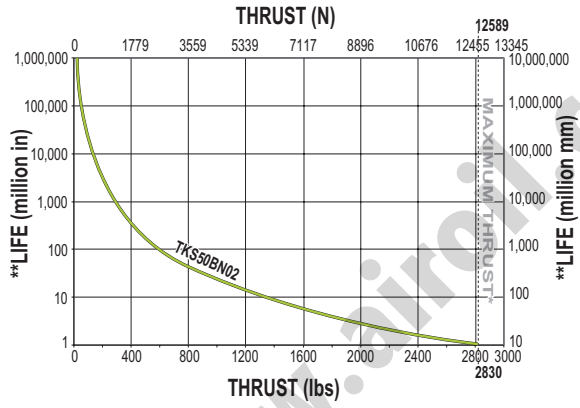

RODLESS

TKS50 Series

- Ball screw critical speed capacities and life calculations

CRITICAL SPEED WITH 0.750" 5TPI ENGLISH BALL SCREW

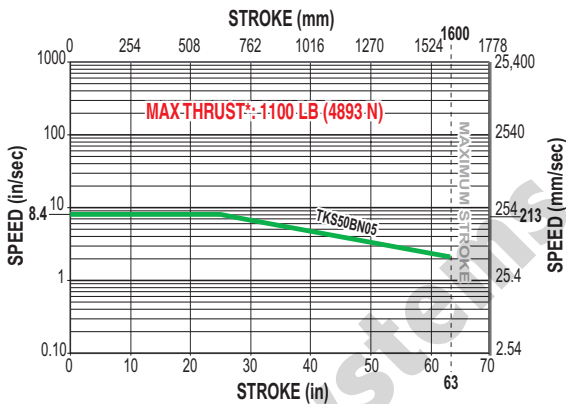

LIFE CALCULATION: 0.750" 5TPI ENGLISH BALL SCREW

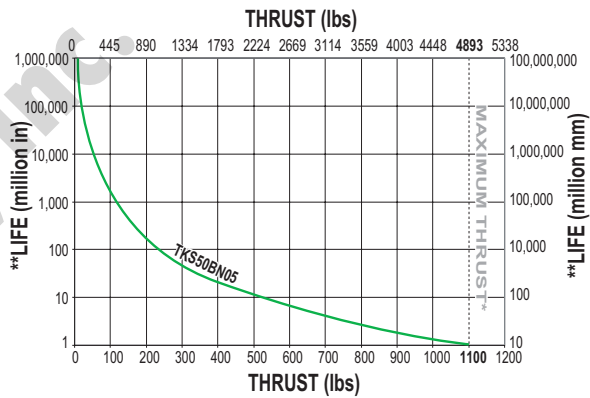

BN = Ball Nut



* Maximum thrust reflects 90% reliability for 1 million linear inches of travel.

**Life indicates theoretical maximum life of screw only, under ideal conditions and does not indicate expected life of actuator.

Axi-dyne[®] TRUTrack™ TKS50 Series

DIMENSIONS

TKS50 ACTUATOR AND OPTIONS DIMENSIONS



RODLESS

TKS50 Series
• Actuator and option dimensions

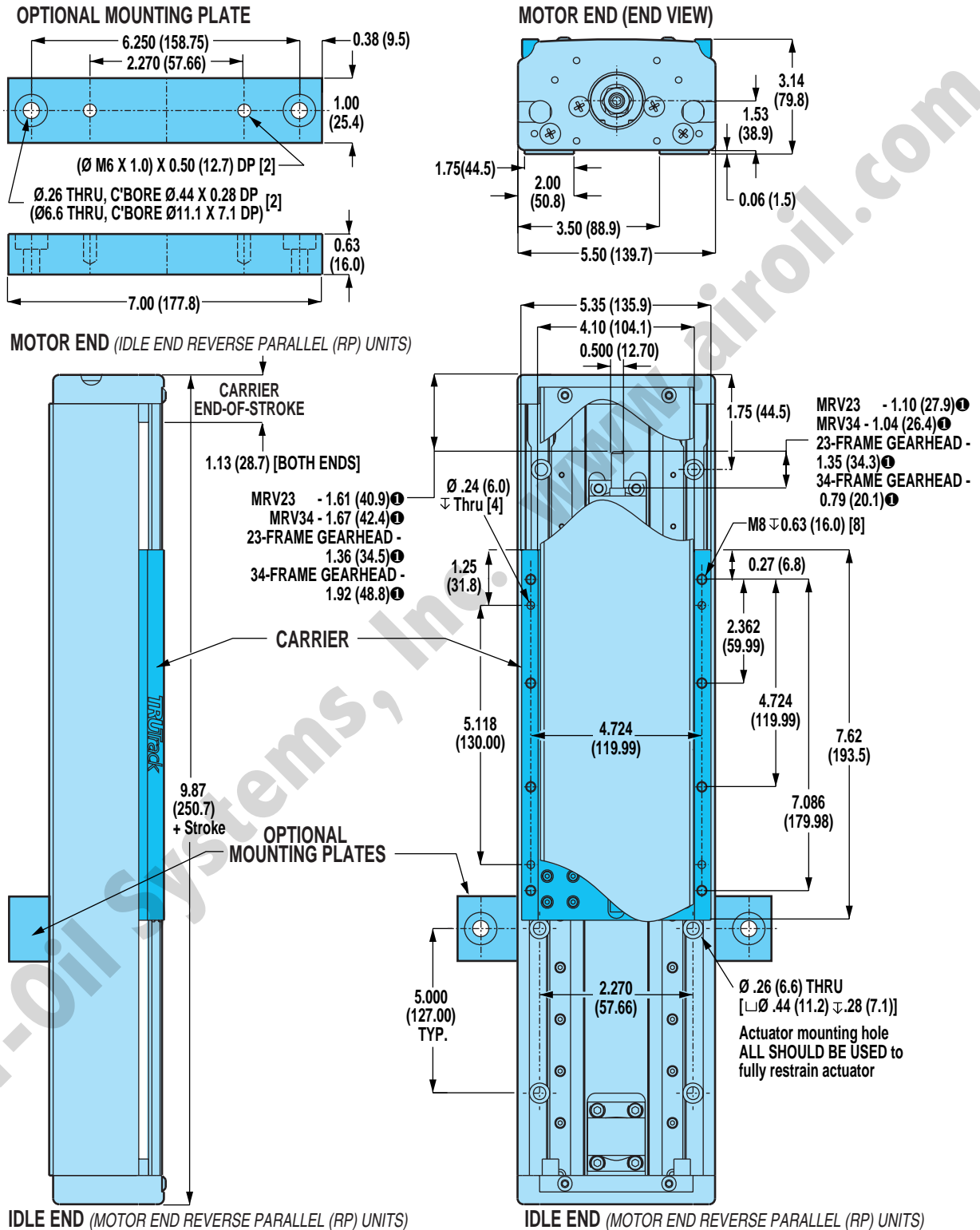

① WHEN SPECIFYING THE XY/XJ SHAFT OPTION: IF A TOL-O-MATIC MOTOR IS NOT SPECIFIED IN THE CONFIGURATION STRING, CUSTOMER'S MOTOR MUST CONFORM TO THE SHAFT DIMENSIONS SHOWN FOR MOUNTING COMPATIBILITY. PLEASE SPECIFY YOUR MOTOR TYPE AND FRAME SIZE WHEN ORDERING.

Unless otherwise noted, all dimensions shown are in inches (Dimensions in parenthesis are in millimeters)

Axi-dyne[®] TRUTrack™ TKS50 Series

DIMENSIONS

TKS50: DOUBLE C-FACE BRAKE OPTION

BRAKE FOR 23-FRAME MOTOR

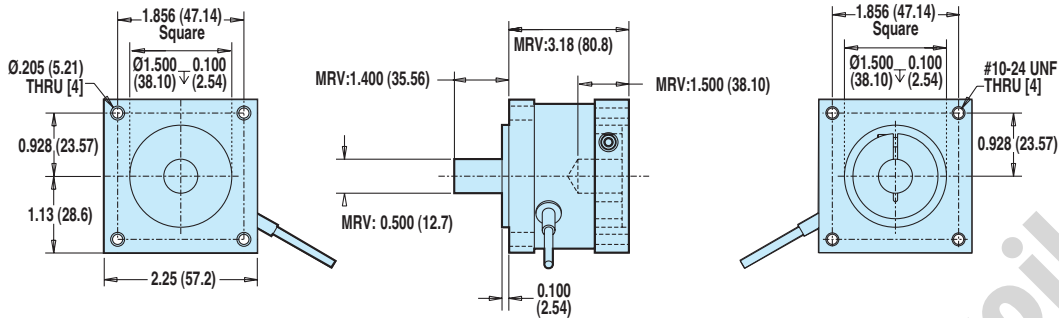

BRAKE FOR 34-FRAME MOTOR

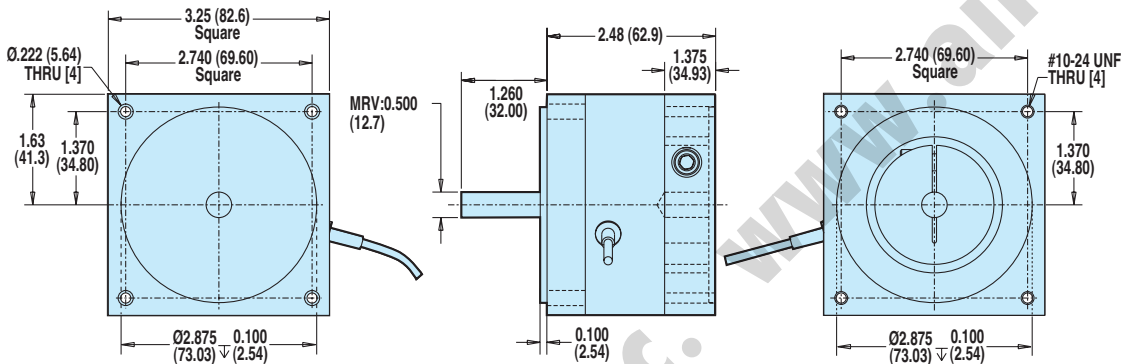

RODLESS

TKS50 Series

- Double C-face brake option dimensions

MOTOR TYPE	MOTOR/ FRAME	BRAKE PART NO.	STATIC TORQUE		REFLECTED INERTIA		WEIGHT		VOLTAGE	CURRENT	RESISTANCE	CABLE LENGTH	
			lb-in	N-m	lb-in ²	kg-m ² x 10 ⁻⁴	lb	kg				Vdc	Amps
BRUSHLESS	MRV 23	3600-6286	10	1.130	0.0125	3.66	1.49	0.68	24	0.286	83.6	16.75	425
	MRV 34	3600-6288	25	2.825	0.1087	31.79	2.88	1.31	24	0.369	65.1	18.00	457

MAXIMUM BRAKE HOLDING LOADS

LEADSCREW/NUT REDUCTION	23-FRAME BRAKE						34-FRAME BRAKE					
	INLINE		5.5:1 GEARHEAD		10:1 GEARHEAD		INLINE		5.5:1 GEARHEAD		10:1 GEARHEAD	
	lb	kg	lb	kg	lb	kg	lb	kg	lb	kg	lb	kg
TKS50 with SN01	105	47.6	300	136.0	300	136.0	262	118.8	300	136.0	300	136.0
TKS50 with BN02	140	63.5	903	409.5	1643	745.2	349	158.3	2259	1024.6	4107	1862.8
TKS50 with BN05	349	158.3	2259	1024.6	4107	1862.8	873	395.9	5647	2561.4	10055	4560.8

⚠ Double C-face brakes are used for static holding (back driving prevention) and are not designed for dynamic stopping. Please contact Tol-O-Matic if your application requires dynamic stopping. This brake can be used with other Tol-O-Matic systems. Consult the factory for availability.

Axi-dyne® TRUTrack™ TKS50 Series

DIMENSIONS

TKS50: IN-LINE MOUNT FOR 23-FRAME BRUSHLESS (MRV) MOTORS OR 23-FRAME GEARHEAD

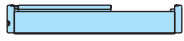

RODLESS

TKS50 Series

- In-line motor mounting dimensions

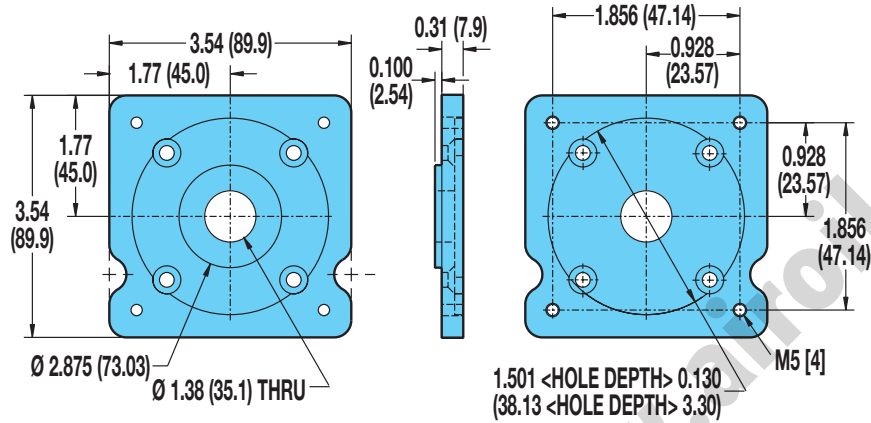

- ⚠ **34-frame brushless MRV motors are mounted directly to the actuator head and require no motor adapter plates.**
- ⚠ **23-frame brushless MRV motors cannot be mounted directly to the actuator head and require the use of the adapter plate shown.**

⚠ **INTERCHANGING MOTORS:** Leadscrews on TruTrack actuators are specific to the motor type specified. Motor mounting plates do not provide for interchanging servo or stepper motors.

For gearhead dimensions and specifications, refer to page F-10.

Axi-dyne® TRUtrack™ TKS50 Series

DIMENSIONS

TKS50: REVERSE PARALLEL MOUNTING

BOTTOM MOUNT

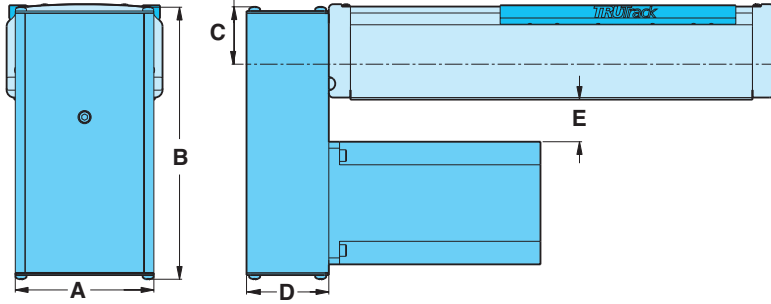

TOP MOUNT

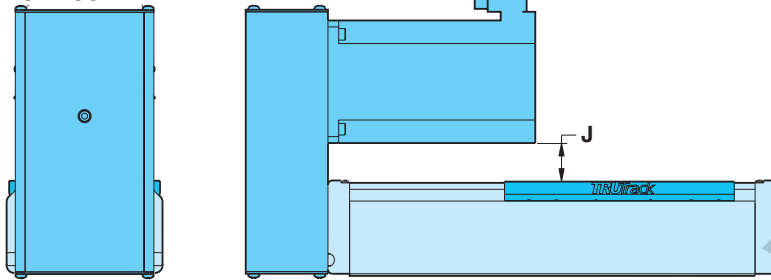

SIDE MOUNT

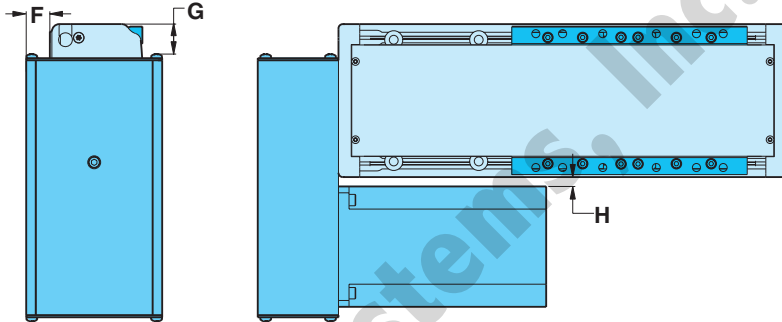

SPECIFICATIONS

BRUSHLESS	MOTOR	WEIGHT OF REDUCTION DRIVE			
		1:1		2:1	
		lbs	kg	lbs	kg
	MRV21, 22, 23, 24	2.85	1.29	3.08	1.40
	MRV31, 32, 33	3.40	1.54	3.56	1.62

RODLESS

TKS50 Series

- Reverse parallel mounting

BRUSHLESS	MOTOR	REDUCTION INERTIA AT MOTOR SHAFT			
		1:1		2:1	
		lb-in ²	kg-cm ²	lb-in ²	kg-cm ²
	MRV21, 22, 23, 24	.036	.1054	.227	.6628
	MRV31, 32, 33	.036	.1054	.227	.6628

REDUCTION EFFICIENCY: 0.95

DIMENSIONS

BRUSHLESS	MOTORS	A		B		C		D		E		F		G		H		J	
		in.	mm	in.	mm	in.	mm	in.	mm	in.	mm	in.	mm	in.	mm	in.	mm	in.	mm
	MRV21, 22, 23, 24	3.25	82.6	7.02	178.4	1.33	33.8	2.13	54.1	1.74	44.2	0.32	8.1	1.07	27.2	0.80	20.3	1.78	45.2
	MRV31, 32, 33	4.00	101.6	7.79	197.9	1.33	33.8	2.38	60.5	0.97	24.6	0.69	17.5	1.07	27.2	0.15	3.8	1.01	25.7

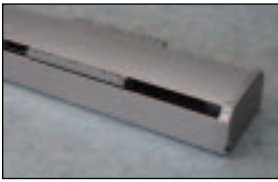

Axi
dyne

TRUTrack™ TKS75 Series ACME SCREW SPECIFICATIONS

TKS75 ACME SCREW CRITICAL SPEED AND PV LIMITS

CRITICAL SPEED WITH 1" 4TPI ENGLISH ACME SCREW

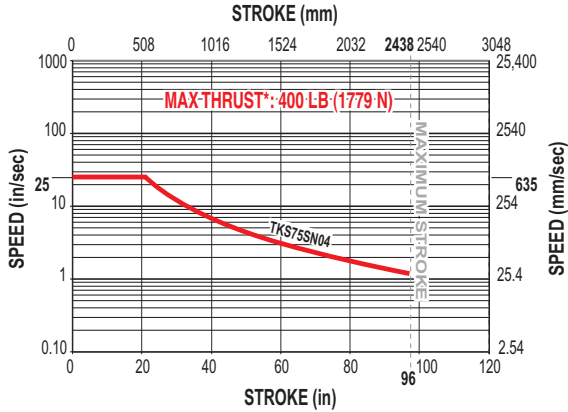

PV LIMITS: 1" 4TPI ENGLISH ACME SCREW

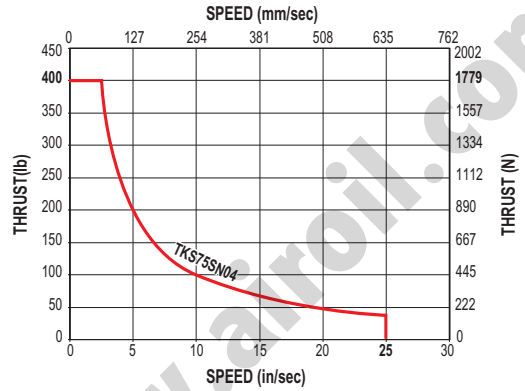

RODLESS

TKS75 Series

- Acme screw critical speed capacities and PV limits

Air-Oil Systems, Inc. www.airoil.com

SN = Solid Nut



* **Maximum thrust is the maximum continuous dynamic thrust subject to Thrust x Velocity limitation.**

PV LIMITS: Any material which carries a sliding load is limited by heat buildup. The factors that affect heat generation rate in an application are the pressure on the nut in pounds per square inch and the surface velocity in feet per minute. The product of these factors provides a measure of the severity of an application.

$$P = \frac{\text{Thrust}}{\text{Max. Thrust Rating}} \times V = \frac{\text{Speed}}{\text{Max. Speed Rating}} \leq 0.1$$

TRUTrack™ TKS75 Series

BALL SCREW SPECIFICATIONS

TKS75 BALL SCREW CRITICAL SPEED AND LIFE CALCULATIONS

CRITICAL SPEED WITH 0.927" ITPI ENGLISH BALL SCREW

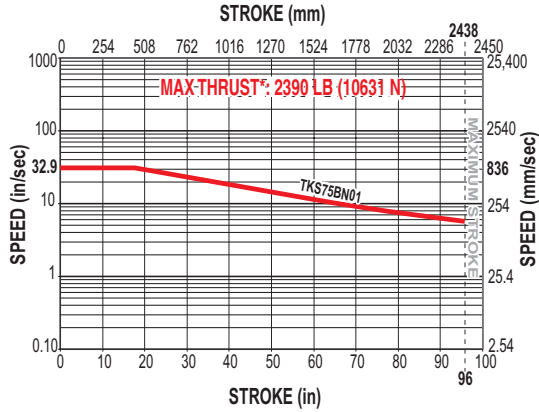

LIFE CALCULATION: 0.927" ITPI ENGLISH BALL SCREW

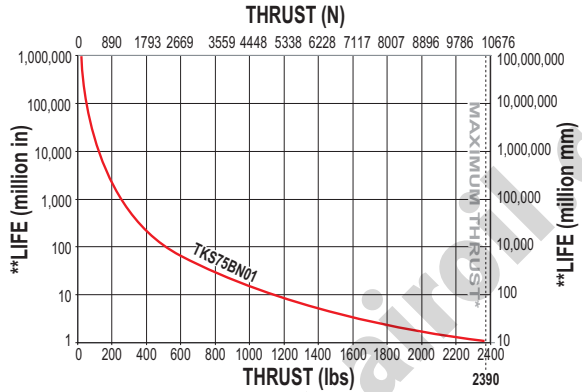

RODLESS

TKS75 Series

- Ball screw critical speed capacities and life calculations

CRITICAL SPEED WITH 0.957" 4TPI ENGLISH BALL SCREW

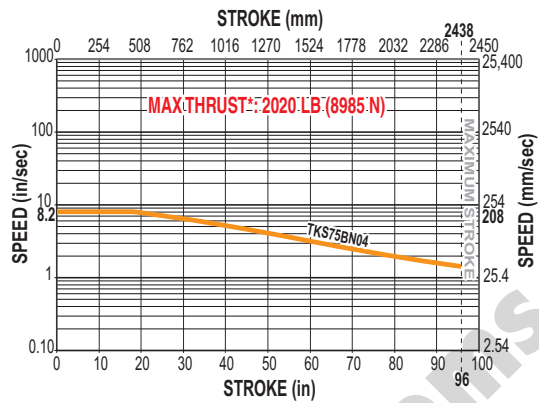

LIFE CALCULATION: 0.957" 4TPI ENGLISH BALL SCREW

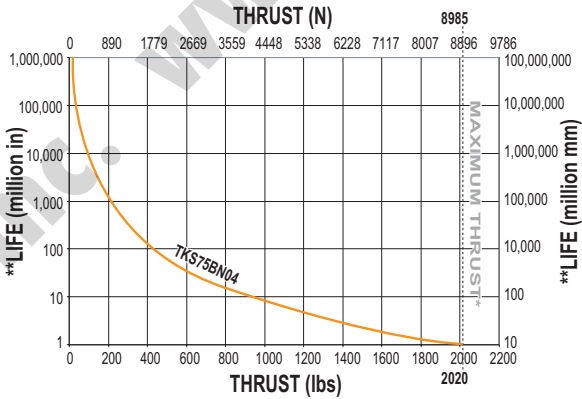

CRITICAL SPEED WITH 1" 2TPI ENGLISH BALL SCREW

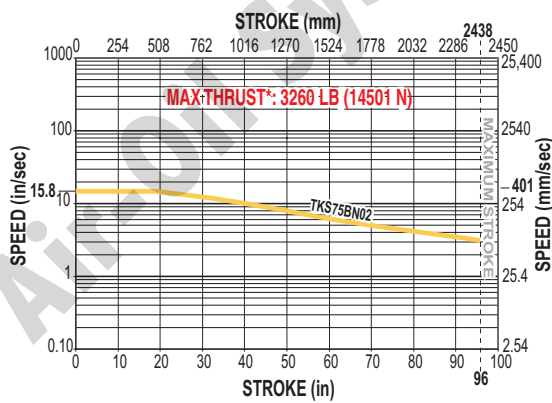

LIFE CALCULATION: 1" 2TPI ENGLISH BALL SCREW

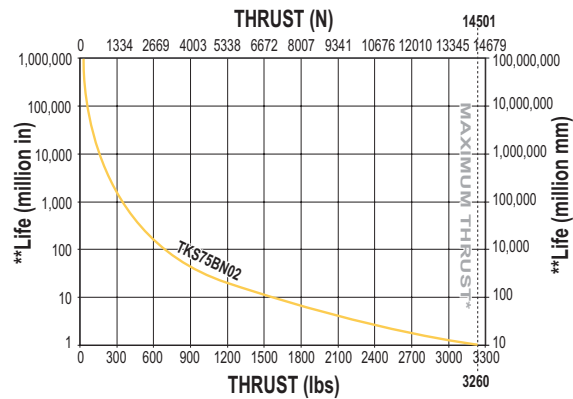

BN = Ball Nut



* Maximum thrust reflects 90% reliability for 1 million linear inches of travel.

**Life indicates theoretical maximum life of screw only, under ideal conditions and does not indicate expected life of actuator.

Axi-dyne[®] TRUTrack™ TKS75 Series

DIMENSIONS

TKS75 ACTUATOR AND OPTIONS



RODLESS

TKS75 Series
• Actuator and options dimensions

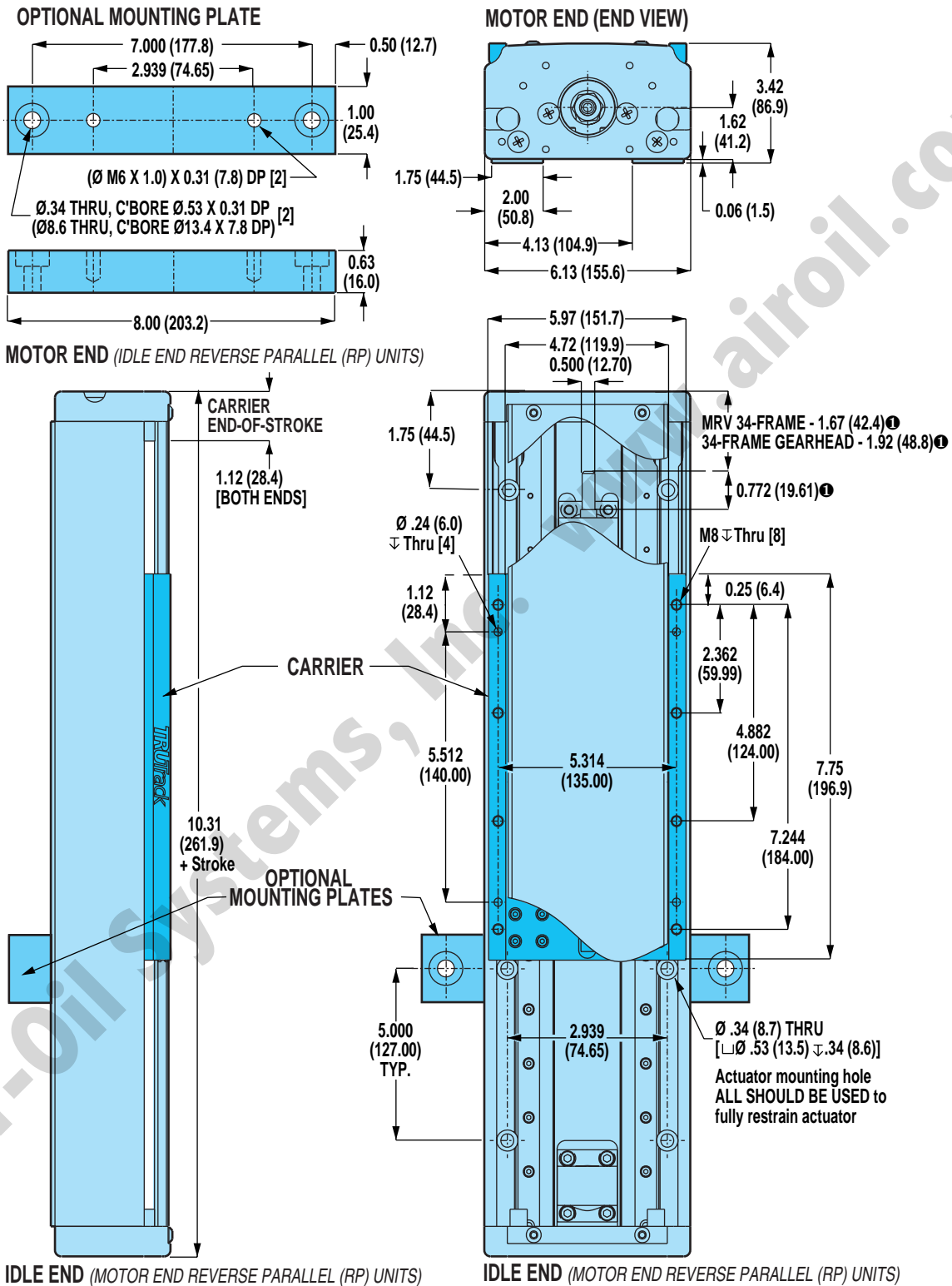

① WHEN SPECIFYING THE XY/XJ SHAFT OPTION: IF A TOL-O-MATIC MOTOR IS NOT SPECIFIED IN THE CONFIGURATION STRING, CUSTOMER'S MOTOR MUST CONFORM TO THE SHAFT DIMENSIONS SHOWN FOR MOUNTING COMPATIBILITY. PLEASE SPECIFY YOUR MOTOR TYPE AND FRAME SIZE WHEN ORDERING.

Unless otherwise noted, all dimensions shown are in inches (Dimensions in parenthesis are in millimeters)

Axi-dyne[®] TRUTrack™ TKS75 Series

DIMENSIONS

TKS75: DOUBLE C-FACE BRAKE OPTION

BRAKE FOR 34-FRAME MOTOR

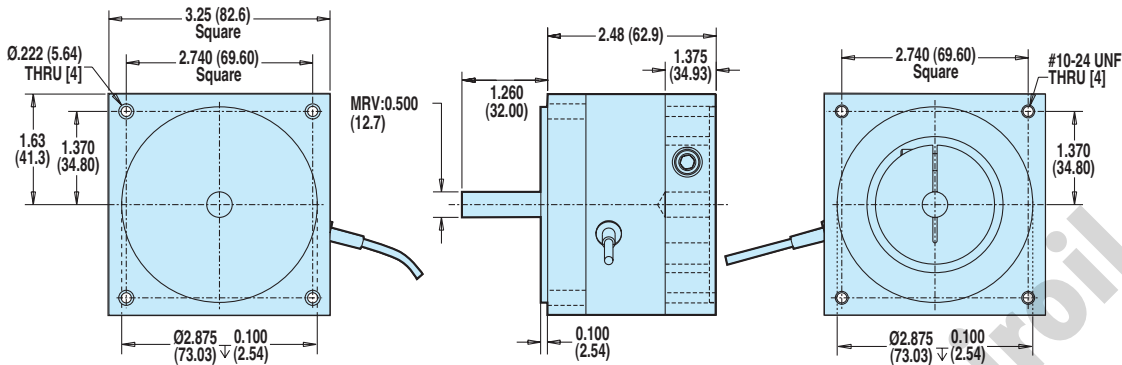

RODLESS

TKS75 Series

- Double C-face brake option
- In-line motor mounting

MOTOR TYPE	MOTOR/ FRAME	BRAKE PART NO.	STATIC TORQUE		REFLECTED INERTIA		WEIGHT		Vdc	CURRENT Amps	RESISTANCE Ohms	CABLE LENGTH	
			lb-in	N-m	lb-in ²	kg-m ² x 10 ⁻⁴	lb	kg				in	mm
BRUSHLESS	MRV 34	3600-6288	25	2.825	0.1087	5.47	2.88	1.31	24	0.369	65.1	18.0	457

MAXIMUM BRAKE HOLDING LOADS

LEADSCREW/NUT REDUCTION	34-FRAME BRAKE					
	INLINE		5.5:1 GEARHEAD		10:1 GEARHEAD	
	lb	kg	lb	kg	lb	kg
TKS75 with SN04	419	190.0	419	190.0	419	190.0
TKS75 with BN01	175	79.3	1129	512.1	2053	931.2
TKS75 with BN02	349	158.3	2259	1024.6	4107	1862.8
TKS75 with BN04	698	316.6	4517	2048.8	8213	3725.3

⚠ Double C-face brakes are used for static holding (back driving prevention) and are not designed for dynamic stopping. Please contact Tol-O-Matic if your application requires dynamic stopping. This brake can be used with other Tol-O-Matic systems. Consult the factory for availability.

TKS75: IN-LINE MOTOR AND GEARHEAD MOUNTING

All brushless servo (MRV) and gearheads may be mounted directly to the actuator head and do not require the use of motor adapter plates.

Reference the MOTOR END (END VIEW) in the dimensional drawing on page C-78



INTERCHANGING MOTORS: Leadscrews on TruTrack actuators are specific to the motor type specified. Motor mounting plates do not provide for interchanging servo or stepper motors.

For gearhead dimensions and specifications, refer to page F-10.

Axi-dyne® TRUTrack™ TKS75 Series

DIMENSIONS

TKS75: REVERSE PARALLEL MOUNTING



RODLESS

TKS75 Series
• Reverse parallel mounting

BOTTOM MOUNT

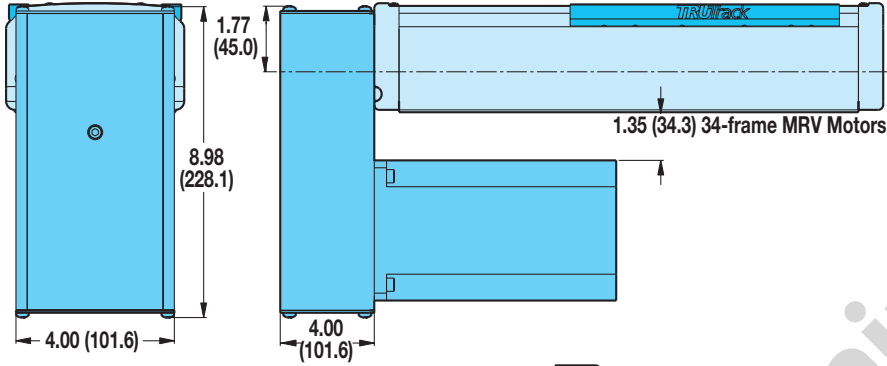

TOP MOUNT

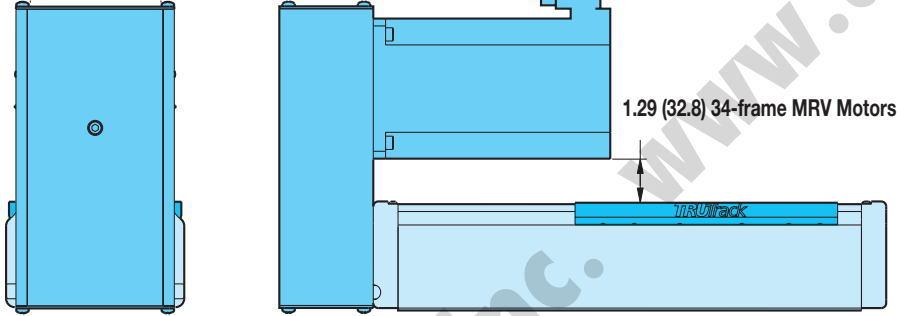

SIDE MOUNT

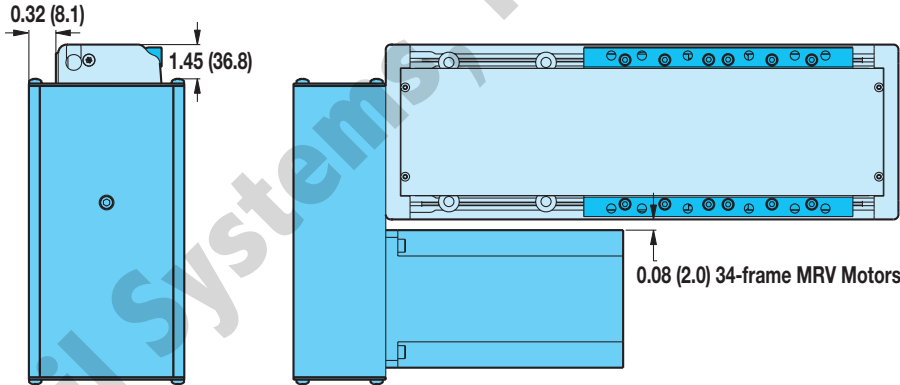

SPECIFICATIONS

MOTOR	WEIGHT OF REDUCTION DRIVE				REDUCTION INERTIA AT MOTOR SHAFT			
	1:1		2:1		1:1		2:1	
	lbs	kg	lbs	kg	lb-in ²	kg-cm ²	lb-in ²	kg-cm ²
BRUSHLESS MRV31, 32, 33	3.40	1.54	3.56	1.62	.036	.1054	.227	.6628

REDUCTION EFFICIENCY: 0.95

Axi-dyne[®] TRUtrack™ TKS Screw Drive

ORDERING

BASE MODEL SPECIFICATIONS

TKS 50 BN02 SK55 LMB

OPTIONS SPECIFICATIONS

DC18 KT2 BE2 BRK LU MP4

MODEL TYPE

TKS TKS Series TruTrack English Screw Drive

PAYLOAD LIMITS

10	100 lbs	50	500 lbs
25	250 lbs	75	750 lbs

NUT/SCREW CONFIGURATION

ENGLISH MODELS

SOLID NUT / PITCH (turn/in)	SERIES
SN01	TKS50
SN02	TKS10, 25
SN04	TKS75

BALL NUT / PITCH (turn/in)	SERIES
BN01	TKS75
BN02	TKS25, 50, 75
BN04	TKS75
BN05	TKS25, 50
BN08	TKS10

STROKE LENGTH

SK Stroke, then enter desired stroke length in decimal inches

MODEL		MAX STROKE* (in)
TKS10	Ball Nut	29
	Solid Nut	96
TKS25	Ball Nut	63
	Solid Nut	96
TKS50	Ball Nut	63
	Solid Nut	96
TKS75	Ball/Solid Nut	96

*Actuator cover has maximum stroke of 48 inches

MOTOR MOUNTING / REDUCTIONS

▲ *The length on the leadscrew and coupling device is determined by motor selection. Motor type and frame size must be specified when ordering. Reference the ordering pages in sections F, G and H for the motor types and selections.*

(must choose one)

LMI In-Line mount
LMB In-Line mount with brake
LMG In-Line mount with gearhead
RPL1 1:1 Reverse-Parallel mount left
RPR1 1:1 Reverse-Parallel mount right
RPB1 1:1 Reverse-Parallel mount bottom
RPT1 1:1 Reverse-Parallel mount top
RPL2 2:1 Reverse-Parallel mount left
RPR2 2:1 Reverse-Parallel mount right
RPB2 2:1 Reverse-Parallel mount bottom
RPT2 2:1 Reverse-Parallel mount top

▲ *When the LMB option is selected, the configurator picks the appropriate screw and hardware to accommodate the mounting of the brake based on motor selection. The brake option "BRK" must also be indicated in the configuration string.*

When the LMG option is selected, the configurator picks the appropriate screw and hardware to accommodate the mounting of the gearhead based on motor selection. A gearhead reduction must also be indicated in the configuration string. Please reference the motor ordering pages for available options.

AUXILIARY CARRIER

DC_ Auxiliary Carrier, then center-to-center spacing desired in decimal inches. (Center-to-Center spacing will add to overall dead length and will not subtract from the stroke length)

SWITCHES

RT_ Reed Switch (Form A) with 5-meter lead, and quantity desired
BT_ Reed Switch (Form C) with 5-meter lead, and quantity desired
KT_ Hall-effect Sinking Switch with 5-meter lead, and quantity desired
TT_ Hall-effect Sourcing Switch with 5-meter lead, and quantity desired
SP_ Sensor Package

*Includes: Two Form C reed switches w/5-meter leads, mounted 1" from end-of-stroke and one Hall-effect sinking switch w/5-meter lead, mounted 2" from end-of-stroke on motor end.

BELLOWS

BE2 Bellows option (increases the dead length of the actuator, see page C-58)

BRAKE OPTION

BRK In-line mounted brake***
 *** Used with the LMB in-line mounting option.

SPECIAL LUBRICATION

LU Low dust generating grease

MOUNTING PLATES

MP_ Mounting Plates plus quantity desired

RODLESS

TKS75 Series

- Ordering

TO ORDER MOTORS/CONTROLS/INTERFACES

 **BRUSHLESS SERVO (SEE PAGE F-33)**

▲ *Not all codes listed are compatible with all options.*

Use the Tol-O-Motion™ Sizing Software to determine available options and accessories based on your application requirements.

FIELD RETROFIT KITS

ITEM	TKS10	TKS25	TKS50	TKS75
Mounting Plates	0601-9803	0602-9803	0603-9803	0604-9803

Customization, Tol-O-Matic does it every day

Tol-O-Matic's ability to provide creative and imaginative solutions for our customers has made us a world leader in the manufacture of automation components. Every Tol-O-Matic product is custom made specifically to your order. Our product line contains over 30,000 base models, most of these manufactured in customer specified strokes. Add on our wide variety of available options and Tol-O-Matic offers literally millions of choices to fit your application. Even with so many choices we encourage you to contact us with your "specials" requirements. We have the resources to create whatever it is you may need.

Exacting precision for a 5-axis milling machine.

Tol-O-Matic worked with this manufacturer to create a prototype specific to their application. Standard RSA rod screw actuators were completely modified with special bearings and precision-matched lead screws to provide the highest possible accuracy, rigidity and ultra low-backlash. A series of six Axidyne DV drives worked with their existing controls and proprietary software system to cue the six legs of actuator motion.

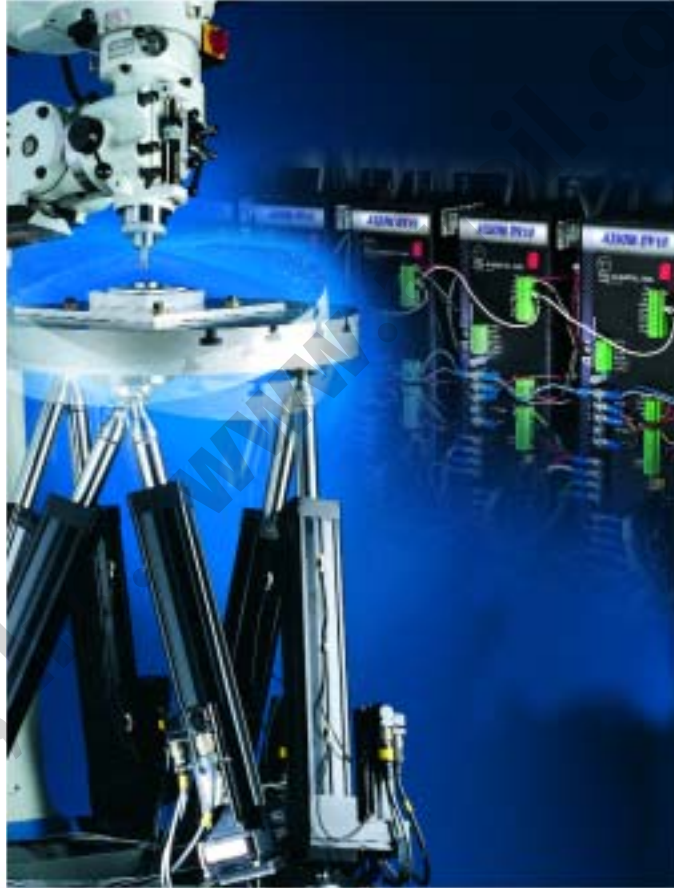

An actuator for an extremely corrosive environment

This standard B3S actuator has a nickel-plated extrusion, other components were made of stainless-steel. A special mounting bracket was created to use with a nonstandard motor.

YES, we can create it.

Tol-O-Matic has created hundreds of special proprietary products for a wide variety of different industries. From simple refinements like creating new mounting brackets or tapped holes to redesigning an existing product, or creating a completely new product, Tol-O-Matic has the resources available to design, test and manufacture whatever you need. Our engineers are available to visit your facility and discuss your special requirements.