

Regulator R08

= "Most Popular"

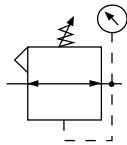

Relieving

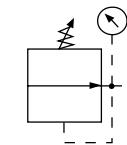

Non-Relieving



R08-01-F0G0



R08-01-F000

Features

- Balanced Valve Design
- 2 Gauge Ports
- Serviceability and Ease of Maintenance
- Unique Flush-mounted Pressure Gauge
- Light Weight
- Modern Design and Appearance

Specifications

Flow Capacity*	1/8	29.2 SCFM (13.5 dm ³ /s)
	1/4	44.0 SCFM (18.9 dm ³ /s)
Adjusting Range Pressure	0 to 30 PSIG (0 to 2.1 bar)	
	0 to 60 PSIG (0 to 4.1 bar)	
	0 to 125 PSIG (0 to 8.6 bar)	

Gauge Port (2 ea.)** NPT	1/8	
Maximum Supply Pressure	300 PSIG (20.7 bar)	
Operating Temperature	32° to 150°F (0° to 65.5°C)	
Port Size	NPT / BSPP-G	1/8, 1/4
Weight	lb. (kg)	.66 (0.3)

* Inlet pressure 100 PSIG (6.9 bar). Secondary pressure 90 PSIG (6.2 bar).

** Non-gauge option only.

Materials of Construction

Adjustment Knob	Acetal
Body	Zinc
Body Cap	ABS
Bonnet	PBT
Bottom Plug	33% Glass-Filled Nylon
Diaphragm Assembly	Brass / Nitrile
Panel Nut	Acetal
Seals	Nitrile
Springs	Steel
Valve Assembly	Brass / Nitrile

WARNING

Product rupture can cause serious injury.
Do not connect regulator to bottled gas.
Do not exceed maximum primary pressure rating.

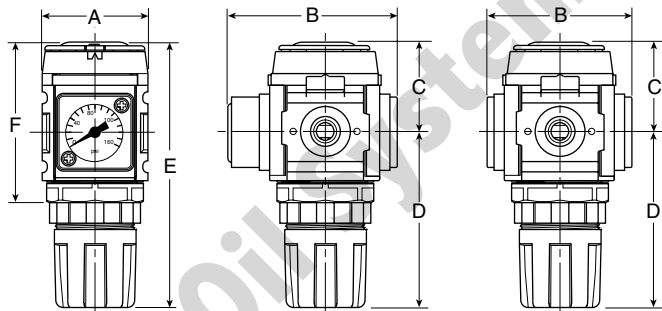

R08-XX-F0G0

R08-XX-F000

NOTES: Flush mounted gauge kits will not fit units originally purchased with threaded gauge ports.

1.25" Dia. (31.7 mm) hole required for panel nut mounting.

CAUTION:

REGULATOR PRESSURE ADJUSTMENT – The working range of knob adjustment is designed to permit outlet pressures within their full range. Pressure adjustment beyond this range is also possible because the knob is not a limiting device. This is a common characteristic of most industrial regulators, and limiting devices may be obtained only by special design.

For best performance, regulated pressure should always be set by increasing the pressure up to the desired setting.

Dimensions

Models	Inches (mm)	A	B	C	D	E	F
Standard Unit R08-XX-F000		1.58 (40)	1.58 (40)	1.34 (34)	2.60 (66)	3.94 (100)	2.40 (61)
With Gauge R08-XX-F0G0		1.58 (40)	2.53 (64)	2.60 (66)	1.34 (34)	3.94 (100)	2.40 (61)

= "Most Popular"

Replacement Kits

- Diaphragm Assembly –
 - Non-relieving GRP-96-726
 - Relieving GRP-96-725
- Spring, Regulating –
 - 0 to 30 PSIG (0 to 2.1 bar) GRP-95-111
 - 0 to 60 PSIG (0 to 4.1 bar) GRP-96-718
 - 0 to 125 PSIG (0 to 8.6 bar) GRP-96-717
- Valve Assembly RRP-96-727
- Valve Spring RRP-96-728

Accessories

- Adjusting Knob RRP-16-005-000
- Bottom Plug RRP-16-383-000
- Gauge Adapter Block, 1/4" NPT, GPA-97-037
Replaces Flush Mount Gauge
- Panel Mount Nut –
 - Aluminum RPA-96-733
 - Plastic RPA-96-734
- Pressure Gauge, Flush Mounted –
 - 0 to 150 PSIG K4511SCR150
 - 0 to 60 PSIG K4511SCR060
 - 0 to 11 bar K4511SCR11B
- Pressure Gauge, 0 to 60 PSIG (0 to 4.1 bar),
1-1/2" Dial Face, 1/8 NPT, CBM K4515N18060
- Pressure Gauge, 0 to 160 PSIG (0 to 11.0 bar),
1-1/2" Dial Face, 1/8 NPT, CBM K4515N18160
- Tamper Resistant Kit RPA-96-735
- Wall Mounting Bracket –
 - C-Type GPA-97-010
 - L-Type GRP-96-739
 - T-Type GPA-96-737

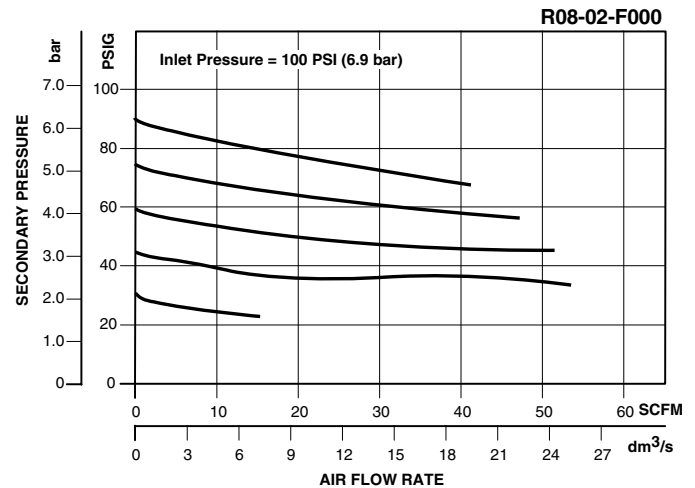
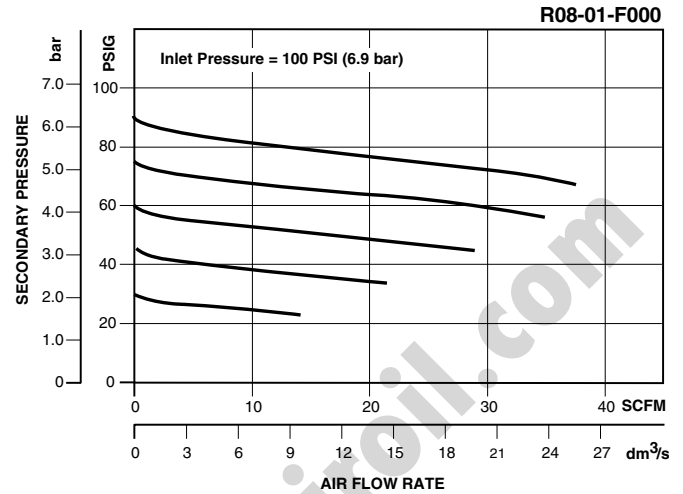

Ordering Information

Model Type	Port Size	With Gauge 0 to 125 PSIG (0 to 8.6 bar)	With Gauge 0 to 30 PSIG (0 to 2.1 bar)	With Gauge 0 to 60 PSIG (0 to 4.1 bar)	Without Gauge 0 to 125 PSIG (0 to 8.6 bar)	Without Gauge 0 to 30 PSIG (0 to 2.1 bar)	Without Gauge 0 to 60 PSIG (0 to 4.1 bar)
Relieving	1/8	R08-01-F0G0	R08-01-C0G0	R08-01-D0G0	R08-01-F000	R08-01-C000	R08-01-D000
	1/4	R08-02-F0G0	R08-02-C0G0	R08-02-D0G0	R08-02-F000	R08-02-C000	R08-02-D000
Non-relieving	1/8	R08-01-R0G0	R08-01-P0G0	R08-01-W0G0	R08-01-R000	R08-01-P000	R08-01-W000
	1/4	R08-02-R0G0	R08-02-P0G0	R08-02-W0G0	R08-02-R000	R08-02-P000	R08-02-W000

Options - To order an option supplied with the unit model, add the appropriate coded suffix letter in the designated position of the model number.

B